

SonoScape

**HDT-500 Trolley
User Manual**



SonoScape Medical Corp

Intended Use

The trolley is used to place the endoscopy system, the monitor and accessories manufactured or provided by the manufacturer.











Precautions

- The trolley can only be used with the endoscopy system and the monitor manufactured or provided by the manufacturer.
- Before the installation, ensure that all the foot brakes are locked. Also, before moving the trolley, ensure that all the foot brakes are released and all cables are away from the casters .
- Before use, ensure that the four casters are intact and can revolve smoothly .
- The bearing limits of the trolley shall not exceed 80 kg. To avoid damaging the trolley, do not overload it.
- Before moving the trolley, adjust the monitor to its minimum height and keep the monitor directly above the trolley. Otherwise, the trolley may fall, causing crushes or bruises.
- To avoid damaging the trolley, move it slowly and carefully and lock the foot brakes after arrival.



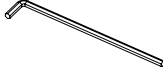

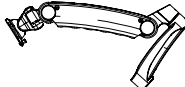





Accessories

Before the installation, ensure that all the following items are intact and in the accessory box. Otherwise, do not use the trolley and contact the local distributor.



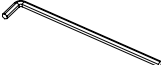

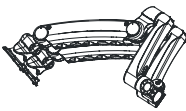





Accessories for Installing a Single Monitor of 24 Inches and Below



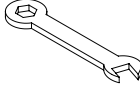

No.	Name	P/N	Picture	Quantity
1	Endoscope slider	1063-02479		2
2	Connector section holder	3602-00824		1
3	Fastening knob	2208-00703		2
4	Swing arm washer	-		1
5	2.5 hexagon spanner	-		1
6	4.0 hexagon spanner	-		1
7	5.0 hexagon spanner	-		1
8	M6 × 10 hexagon half-round head screw	1500-00294		2
9	Swing arm	2208-00839		1
10	Monitor fixing plate	2208-02796		1
11	M4 × 12 cross pan head screw	1500-00438		7

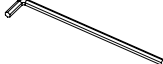
Accessories for Installing Dual Monitors of 24 Inches and Below

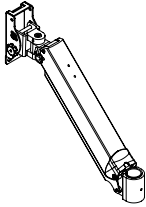
No.	Name	P/N	Picture	Quantity
1	Endoscope slider	1063-02479		2
2	Connector section holder	3602-00824		1
3	Fastening knob	2208-00703		2
4	Swing arm washer	-		1
5	2.5 hexagon spanner	-		1
6	4.0 hexagon spanner	-		1
7	5.0 hexagon spanner	-		1
8	M6 × 10 hexagon half-round head screw	1500-00294		2
9	Swing arm	2208-02307		1
10	Monitor fixing plate	2208-02796		2
11	M4 × 12 cross pan head screw	1500-00438		11

Accessories for the Monitor of 26 Inches and Above

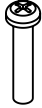
No.	Name	P/N	Picture	Quantity
1	Endoscope slider	1063-02479		2
2	Connector section holder	3602-00824		1
3	Fastening knob	2208-00703		2
4	Swing arm washer	-		1
5	Stay wrench	-		1
6	M8 nuts and washers	-		2
7	3.0 hexagon spanner	-		1
8	4.0 hexagon spanner	-		1
9	5.0 hexagon spanner	-		1
10	M6 × 10 hexagon half-round head screw	1500-00294		2
11	Swing arm	2208-03558		1

No.	Name	P/N	Picture	Quantity
12	Monitor fixing plate	2208-03639		1
13	M4 × 12 cross pan head screw	1500-00438		7
14	M4 × 20 cross pan head screw	-		4
15	M4 × 25 cross pan head screw	-		4

Parts

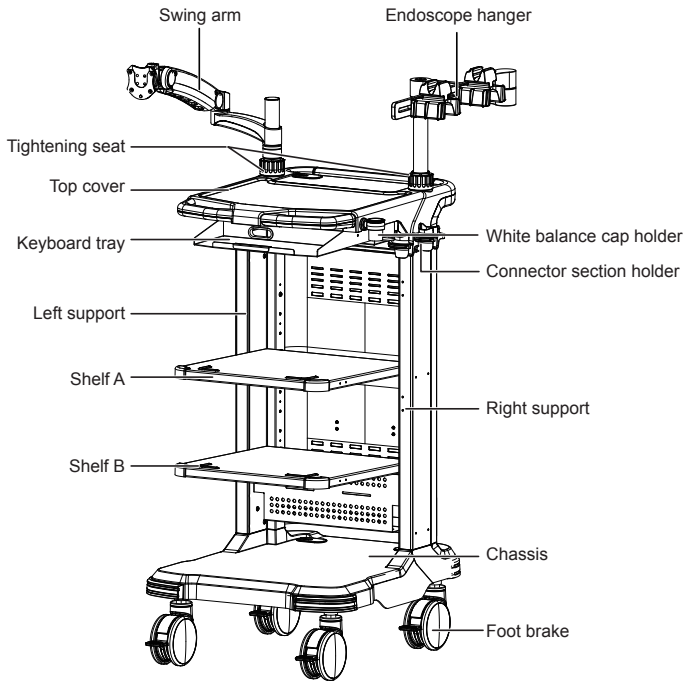

Figure 1 Front View

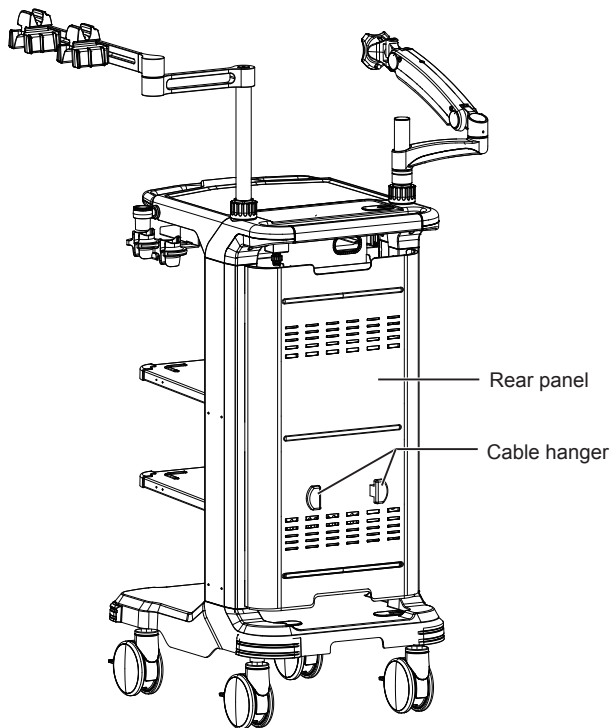

Figure 2 Rear View

Installing the Trolley

Perform the following steps.

1. Install the endoscope slide.
 - a. Rotate the endoscope hanger to the desired position.
 - b. Lock the two endoscope sliders on the endoscope hanger respectively with the two fastening knobs.

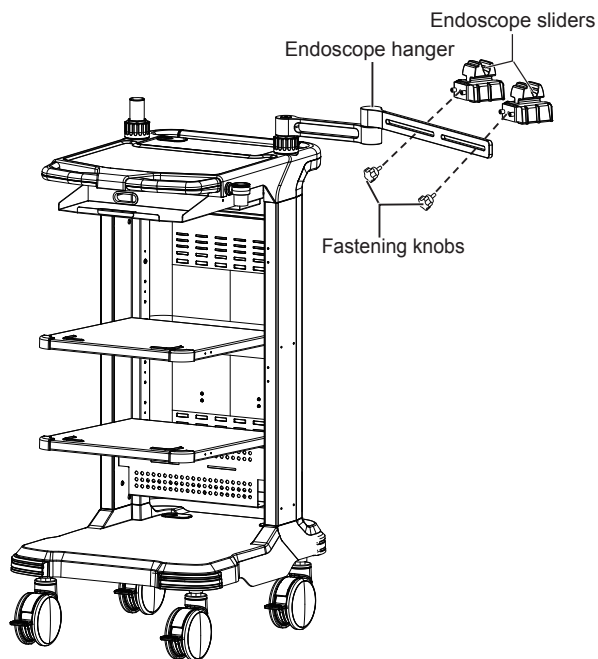

Figure 3 Install the Endoscope Sliders

2. Fix the connector section holder under the right side of the top cover with three M4 × 12 cross pan head screws.

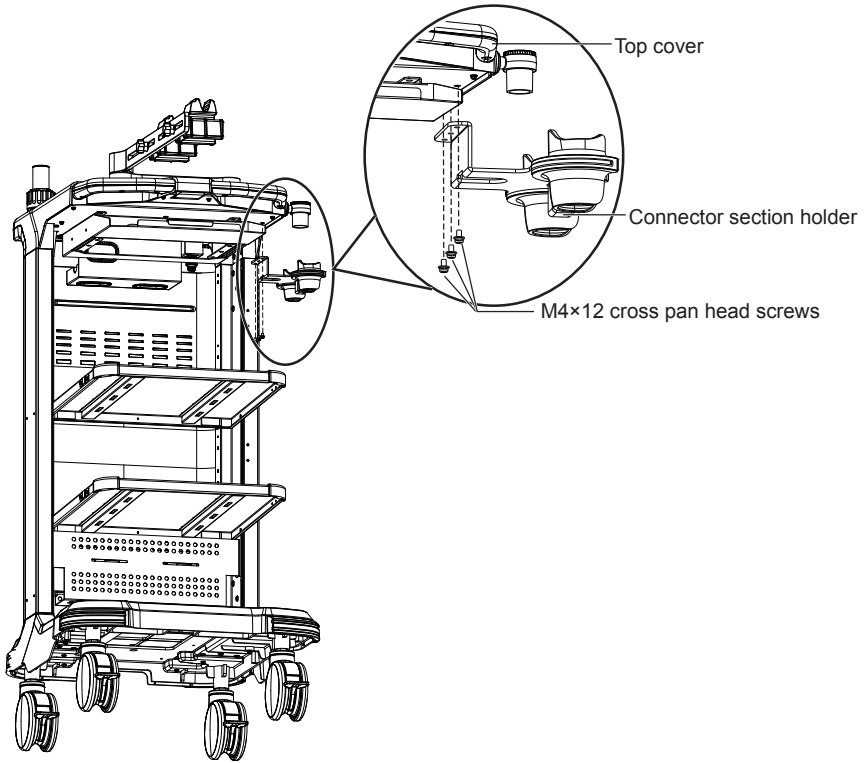

Figure 4 Installing the Connector Section Holder

3. Adjust the height of the endoscope hanger and the swing arm bracket.

NOTE:

When adjusting the height of the endoscope hanger and the swing arm bracket, hold tightly the endoscope hanger and swing arm bracket to avoid crushing.

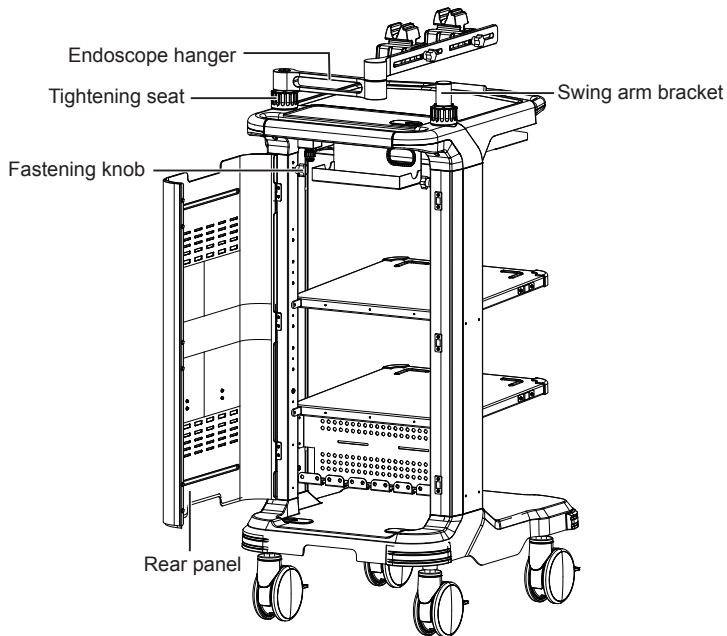

Figure 5 Adjusting the Height of Endoscope Hanger

- a. Open the rear panel and unscrew the fastening knob and the tightening seat on the right support in turn.
- b. Lift or lower the endoscope hanger to desired height.
- c. Screw the tightening seat and the fastening knob on the right support in turn.

Adjust the height of the swing arm bracket in the same way as the endoscope hanger height adjustment.

4. Tighten screws on the left and right supports.
 - a. Tighten one M6 × 10 hexagon half-round head screw on the left support by the 4.0 hexagon spanner to avoid swing arm falling, as shown in Figure 6.

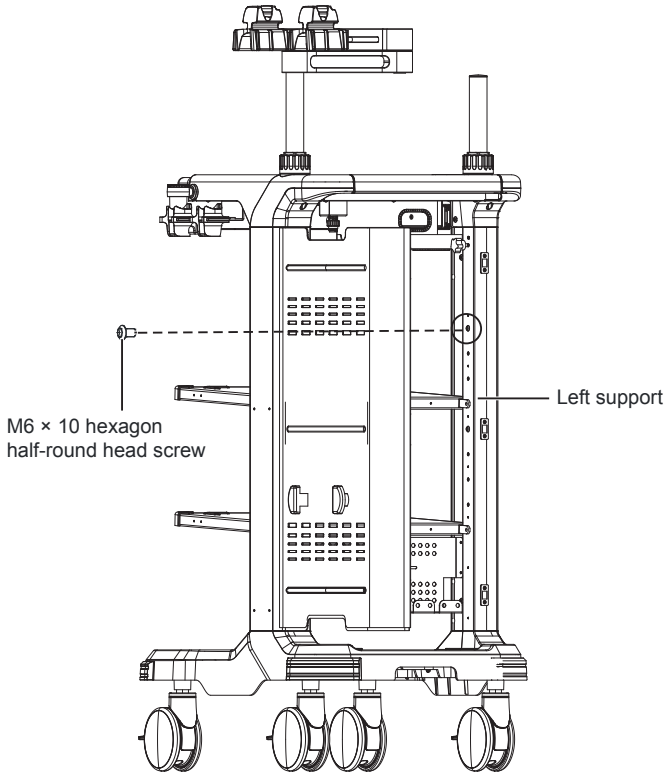

Figure 6 Tightening the Screw on the Left Support

- b. Tighten one M6 × 10 hexagon half-round head screw on the right support by the 4.0 hexagon spanner to avoid endoscope hanger falling that causes crushing, as shown in Figure 7.

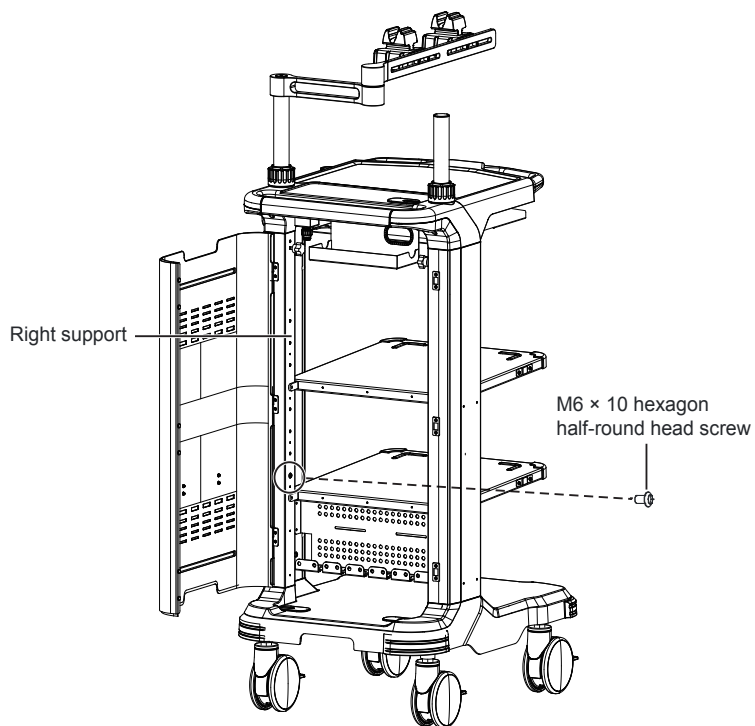

Figure 7 Tightening the Screw on the Right Support

5. Install the swing arm.
 - Install the single swing arm for the monitor of 24 inches and below.

NOTE:

The bearing limits of the arm is 12 kg. Do not overload to avoid damaging the device.

Install the swing arm washer and the single swing arm on the swing arm support in turn.

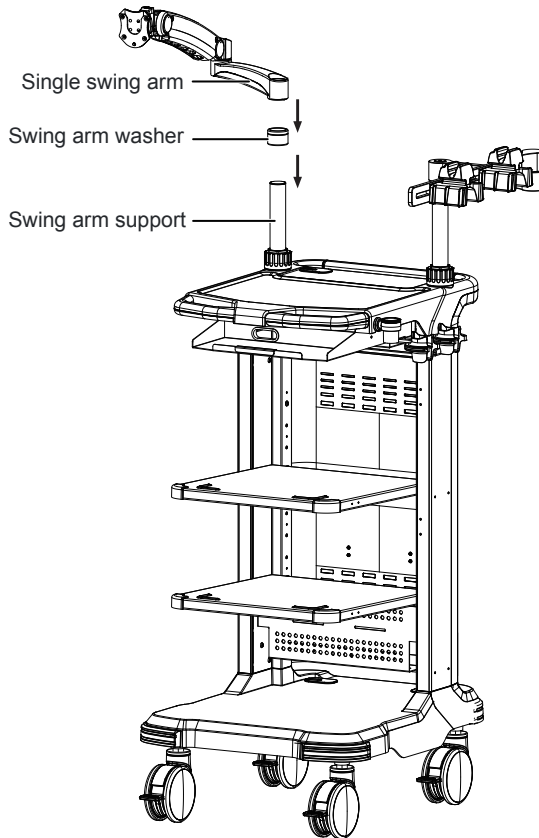

Figure 8 Installing the Single Swing Arm

- Install the dual swing arm for dual monitors of 24 inches and below.

NOTE:

The bearing limits of the arm is 12 kg. Do not overload to avoid damaging the device.

- a. Install the swing arm washer and the dual swing arm on the swing arm support in turn.

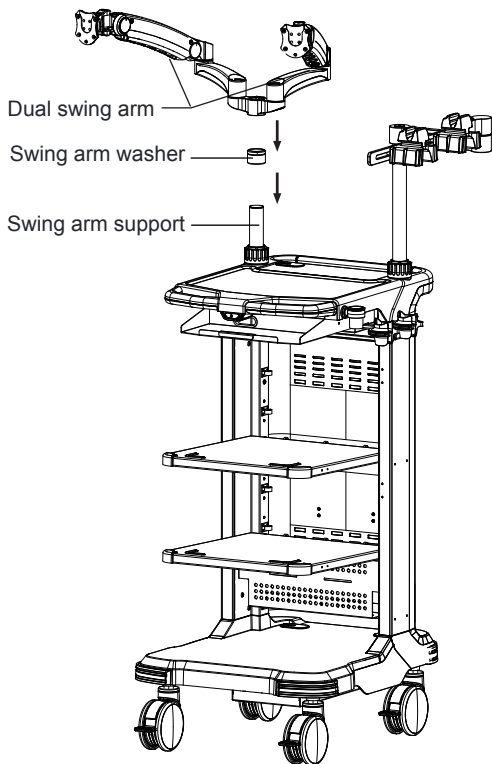

Figure 9 Installing the Dual Swing Arm

- b. Fasten one M6 × 20 hexagon round head screw on the swing arm chassis by the 4.0 hexagon spanner.

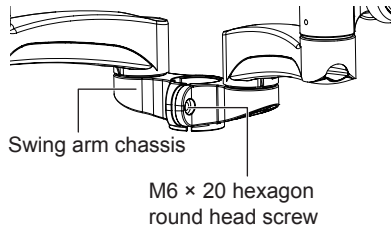

Figure 10 Fastening the Screw on the Swing Arm Chassis

- Install the single swing arm for the monitor of 26 inches and above.

NOTE:

- The bearing limits of the arm is 18-25 kg. Do not overload to avoid damaging the device.
- This arm is also suitable for the monitor of 24 inches and below.

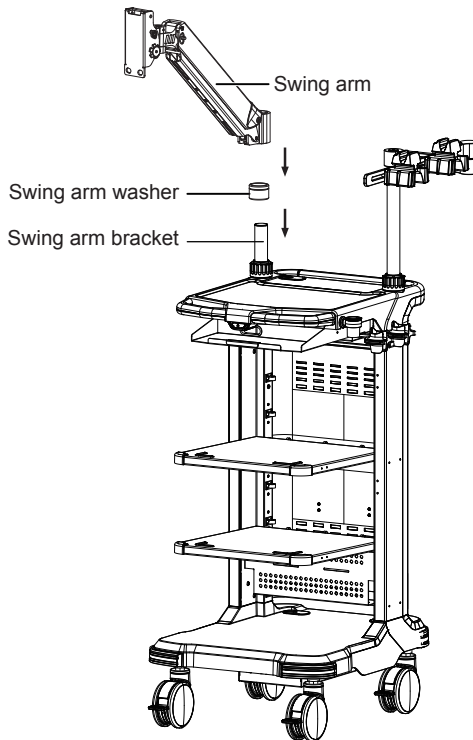

Figure 11 Install the Swing Arm

- a. Install the swing arm washer onto the swing arm bracket and fasten the washer.
- b. Install the swing arm onto the swing arm bracket and use the hexagon wrench to fasten the screw on the swing arm to lock the swing arm.

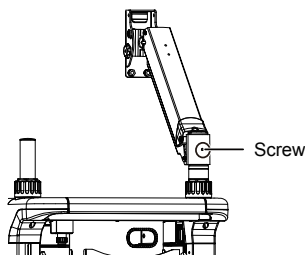

Figure 12 Fastening the Swing Arm Screw

Using the Trolley

Perform the following steps.

1. Lock the foot brakes of the trolley, and put the light source on the shelf A steadily. Ensure that the light source is within the area delimited by the anti-slip strips.

NOTE:

- Such equipment as high frequency electrotome and printer is recommended to be placed on the shelf B.
 - The bearing limits of the top cover, shelf A, shelf B and chassis shall not exceed 40 kg respectively, and the bearing limits of the trolley shall not exceed 80 kg. To avoid damaging the trolley, do not overload.
 - Remove the four screws used to fix the shelf A or shelf B to adjust the shelf height, if necessary.
 - The distance between two height adjusting holes is 5 cm.
2. Place the image processor on the light source steadily.
 3. Install the monitor.

NOTE:

Hang two monitors on the trolley only when the light source and the image processor are placed on the trolley.

- Installing the monitor of 24 inches and below.
- a. Use four M4 × 12 cross pan head screws to fix the monitor fixing plate on the back of the monitor, as shown in Figure 13.

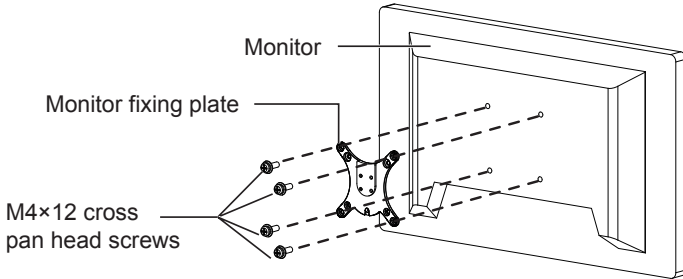

Figure 13 Installing the Monitor Fixing Plate

- b. Put back the circular pin on the swing arm to fix the block on the monitor fixing plate into the front groove of the swing arm. Ensure that the block is fixed into the groove completely and loose with the circular pin.

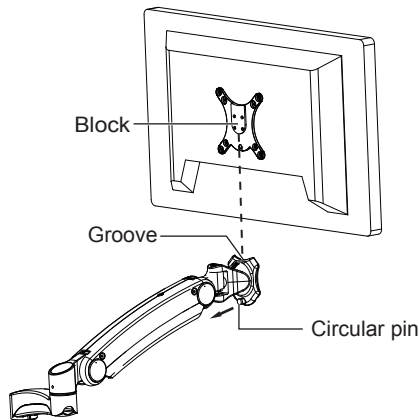

Figure 14 Installing the Monitor

If dual monitors need to be installed, repeat step a and step b to

install another monitor.

- Installing the monitor of 26 inches and above.
- a. Use four M4 × 20 cross pan head screws or four M4 × 25 cross pan head screws according to different monitors to fix the monitor fix plate onto the back of the monitor; as shown in Figure 15.

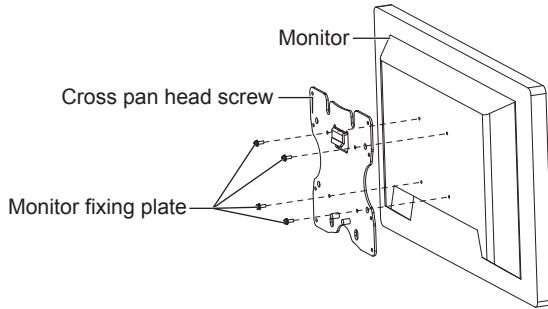

Figure 15 Installing Monitor Fixing Plate

- b. Fix the block on the monitor fixing plate into the groove on the swing arm front and ensure that the block is completely fixed in, as is shown in Figure 16.

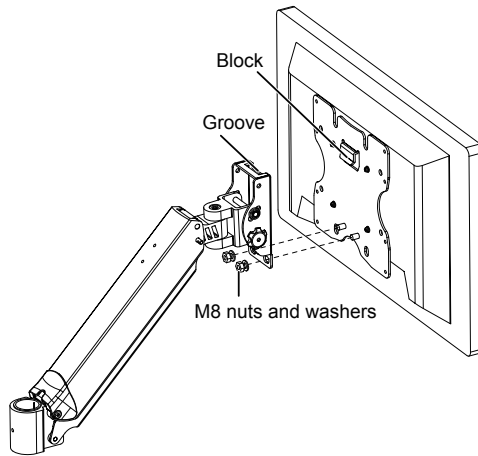

Figure 16 Installing the Monitor

- c. Use two M8 nuts and washers to fix the monitor.

4. Hang the control section of the endoscope on the endoscope hanger, and put the connector section of the endoscope on the connector section holder, as shown in Figure 17.

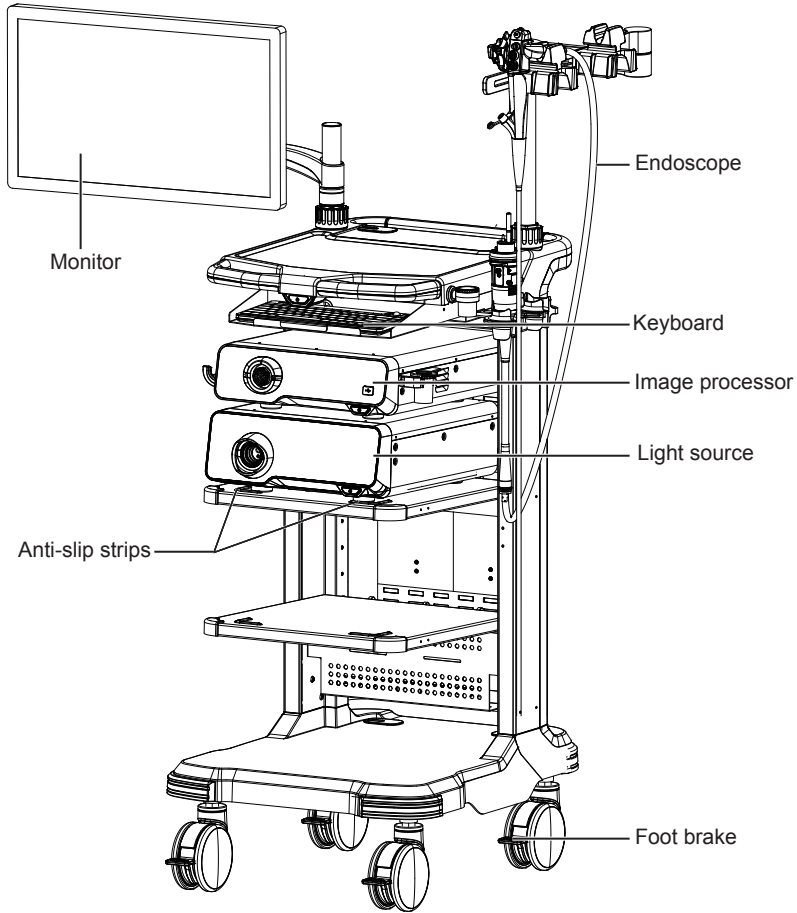

Figure 17 Placing the Devices

Adjusting Monitor Height

Rotate the knob on the upper part of the swing arm clockwise by using the 5.0 hexagon spanner to raise the monitor. Rotate the knob anticlockwise to lower the monitor.

NOTE:

The height of the monitor of 26 inches and above cannot be adjusted.

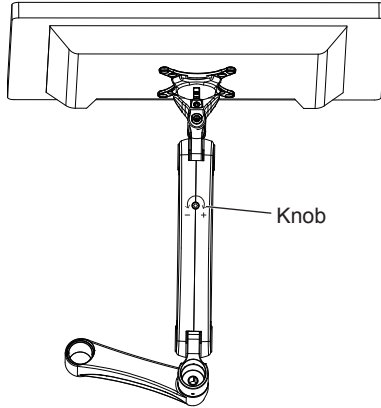

Figure 18 Adjusting Monitor Height

Adjusting the Flexibility of Endoscope Hanger

Rotate the knob of the endoscope hanger clockwise by using the 5.0 hexagon spanner to increase the flexibility of the hanger. Rotate the knob anticlockwise to reduce the flexibility.

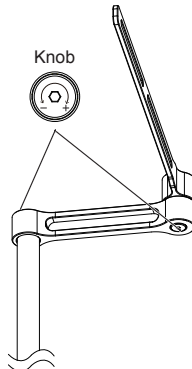

Figure 19 Adjusting the Flexibility

Isolation Power EC800PE (Optional)



- The isolation power is only used for the device manufactured or approved by the manufacturer, otherwise, the device may be damaged.
- Before powering off the equipment connected to the trolley, do not power off the trolley.

Before shipping, the isolation power is fixed under the trolley chassis. Refer to the isolation power user manual for detailed precautions and using methods.

Cleaning and Maintenance

Cleaning



- Wear personal protective equipment when cleaning the device. Otherwise, blood, mucous membrane and other potential source of infection adhered to the device may cause infection.
- The device should be completely dried after being wiped with a damp cloth. Otherwise, electric shock may occur.

If the trolley is contaminated, perform the following cleaning procedures immediately after use. If cleaning is delayed, residual debris will be solidified, and it may be difficult to effectively clean the trolley.

Perform the following steps.

1. If the trolley is configured with the isolation power, power off the trolley, and then unplug it.
2. Remove the devices from the trolley.
3. Dampen a lint-free soft cloth with 75% ethyl alcohol to clean the surface of the trolley.

Maintenance

To ensure that all parts of the trolley are connected securely, maintenance must be performed at least once every year.

Customer Service

Only the service personnel of or authorized by the manufacturer can service the device. Any feedback or inquiries concerning our product or services should be directed to the manufacturer.

Contact address: 2F, 12th Building, Shenzhen Software Park Phase II, Keji Middle 2nd Road, Nanshan District, Shenzhen, 518057, Guangdong, China

Tel: +86-755-26722890

E-mail: service@sonoscape.net

SonoScape Medical Corp.

Address: Room 201 & 202, 12th Building, Shenzhen Software Park
Phase II, 1 Keji Middle 2nd Road, Yuehai Subdistrict, Nanshan District,
Shenzhen, 518057, Guangdong, China

Tel: +86-755-26722890

Fax: +86-755-26722850

E-mail: sonoscape@sonoscape.net

www.sonoscape.com

4710-01401A05

