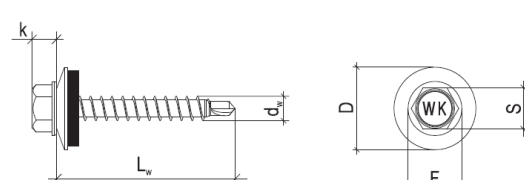

DECLARATION OF PERFORMANCE No 17/SZ/16

- Unique identification code of the product-type: **WFD, WFDOC, WFDx, WFD-D, A2-WFD**
- Intended use/es: **Fastening screws for metal members and sheeting**
- Manufacturer: **KLIMAS Sp. z o.o.
ul. Wincentego Witosa 135/137
Kuźnica Kiedrzyńska 42-233 Mykanów**
- Authorised representative: **not applicable**
- System/s of AVCP: **system 2+**
- European Assessment Document:
 - European Assessment Document (EAD) 330046-01-0602 „Fastening screws for metal members and sheeting”**
 - European Technical Assessments – ETA-16/0443 of 30/06/2016**
 - Instytut Techniki Budowlanej**
 - Identification number of notified body- 1488**
- Declared performance/s:

Self-drilling screws with hexagon head and sealing washer WFD-4,8 x L, WFDOC-4,8 x L, WFDx-4,8 x L, WFD-D-4,8 x L											
Material Fastener: carbon steel – SAE1022 or 19MnB4 quenched, tempered and galvanized Washer: EPDM sealing ring with metal top made of aluminium, coated carbon steel or stainless steel Component I: S280GD, S320GD or S350GD – EN 10346 Component II: structural timber – EN 14081		 <p> $d_w = 4,8 \text{ mm}$ $L_w = 25-100 \text{ mm}$ $s = 8 \text{ mm}$ $k = 4,5 \text{ mm}$ </p>									
Drilling capacity: $\Sigma t_i \leq 2,5 \text{ mm}$											
Timber substructures For timber substructures performance assessed with $M_{ly,Rk} = 4,390 \text{ Nm}$ $f_{ax,k} = 12,867 \text{ N/mm}^2$ for $l_{ef} \geq 20 \text{ mm}$ $f_{ax,k} = 12,015 \text{ N/mm}^2$ for $l_{ef} \geq 30 \text{ mm}$											
Characteristic resistance of shear and pull-out load											
$t_{N,II} [\text{mm}]$	0,50	0,55	0,63	0,75	0,88	1,00	1,25	1,50	Wood class $\geq \text{C24}$		
$M_{t,nom}$	3 Nm								20 mm	30 mm	
Resistance of shear load $V_{R,k} [\text{kN}]$ for $t_{N,II} [\text{mm}]$	0,50	0,55	0,63	0,75	0,88	1,00	1,25	1,50	20 mm	30 mm	*bearing resistance of component I
	—	—	—	—	—	—	—	—	1,10*	1,10*	
	—	—	—	—	—	—	—	—	1,10*	1,10*	
	—	—	—	—	—	—	—	—	1,50*	1,50*	
	—	—	—	—	—	—	—	—	1,74*	1,74*	
	—	—	—	—	—	—	—	—	1,74*	1,74*	
	—	—	—	—	—	—	—	—	1,74*	1,74*	
	—	—	—	—	—	—	—	—	1,74*	1,74*	
	—	—	—	—	—	—	—	—	1,74*	1,74*	
	—	—	—	—	—	—	—	—	—	—	
	—	—	—	—	—	—	—	—	—	—	

DECLARATION OF PERFORMANCE No 17/SZ/16

Resistance of pull-out load $N_{R,k}$ [kN] for $t_{N,I}$ [mm]	0,50	—	—	—	—	—	—	—	—	1,24*	1,73*
	0,55	—	—	—	—	—	—	—	—	1,24*	1,73*
	0,63	—	—	—	—	—	—	—	—	1,24*	1,73*
	0,75	—	—	—	—	—	—	—	—	1,24*	1,73*
	0,88	—	—	—	—	—	—	—	—	1,24*	1,73*
	1,00	—	—	—	—	—	—	—	—	1,24*	1,73*
	1,13	—	—	—	—	—	—	—	—	1,24*	1,73*
	1,25	—	—	—	—	—	—	—	—	1,24*	1,73*
	1,50	—	—	—	—	—	—	—	—	—	—
	1,75	—	—	—	—	—	—	—	—	—	—
	2,00	—	—	—	—	—	—	—	—	—	—
	*bearing resistance of component II										

Self-drilling screws with hexagon head and sealing washer WFD-5,5 x L, WFD0C-5,5 x L, WFDx-5,5 x L, WFD-D-5,5 x L

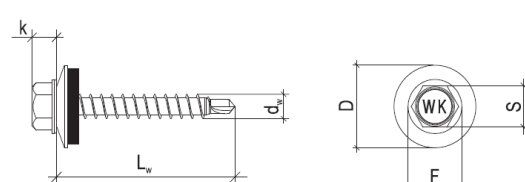
<p>Material</p> <p>Fastener: carbon steel – SAE1022 or 19MnB4 quenched, tempered and galvanized</p> <p>Washer: EPDM sealing ring with metal top made of aluminium, coated carbon steel or stainless steel</p> <p>Component I: S280GD, S320GD or S350GD – EN 10346</p> <p>Component II: structural timber – EN 14081</p>	 <p>$d_w = 5,5 \text{ mm}$ $L_w = 25-100 \text{ mm}$ $s = 8 \text{ mm}$ $k = 4,5 \text{ mm}$</p>
<p>Drilling capacity: $\Sigma t_i \leq 2,5 \text{ mm}$</p> <p>Timber substructures</p> <p>For timber substructures performance assessed with $M_{y,Rk} = 4,390 \text{ Nm}$ $f_{ax,k} = 12,867 \text{ N/mm}^2$ for $l_{ef} \geq 20 \text{ mm}$ $f_{ax,k} = 12,015 \text{ N/mm}^2$ for $l_{ef} \geq 30 \text{ mm}$</p>	

Characteristic resistance of shear and pull-out load

$t_{N,II}$ [mm]	0,50	0,55	0,63	0,75	0,88	1,00	1,25	1,50	Wood class \geq C24		
$M_{t,nom}$	3 Nm								20 mm	30 mm	
Resistance of shear load $V_{R,k}$ [kN] for $t_{N,I}$ [mm]	0,50	—	—	—	—	—	—	—	1,10*	1,10*	
	0,55	—	—	—	—	—	—	—	1,10*	1,10*	
	0,63	—	—	—	—	—	—	—	1,50*	1,50*	
	0,75	—	—	—	—	—	—	—	1,74*	1,74*	
	0,88	—	—	—	—	—	—	—	1,74*	1,74*	
	1,00	—	—	—	—	—	—	—	1,74*	1,74*	
	1,13	—	—	—	—	—	—	—	1,74*	1,74*	
	1,25	—	—	—	—	—	—	—	1,74*	1,74*	
	1,50	—	—	—	—	—	—	—	—	—	
	1,75	—	—	—	—	—	—	—	—	—	
	2,00	—	—	—	—	—	—	—	—	—	
	*bearing resistance of component I										

DECLARATION OF PERFORMANCE No 17/SZ/16

Resistance of pull-out load $N_{R,k}$ [kN] for $t_{N,I}$ [mm]	0,50	—	—	—	—	—	—	—	—	1,24*	1,73*
	0,55	—	—	—	—	—	—	—	—	1,24*	1,73*
	0,63	—	—	—	—	—	—	—	—	1,24*	1,73*
	0,75	—	—	—	—	—	—	—	—	1,24*	1,73*
	0,88	—	—	—	—	—	—	—	—	1,24*	1,73*
	1,00	—	—	—	—	—	—	—	—	1,24*	1,73*
	1,13	—	—	—	—	—	—	—	—	1,24*	1,73*
	1,25	—	—	—	—	—	—	—	—	1,24*	1,73*
	1,50	—	—	—	—	—	—	—	—	—	—
	1,75	—	—	—	—	—	—	—	—	—	—
	2,00	—	—	—	—	—	—	—	—	—	—
	*bearing resistance of component II										

Self-drilling screws with hexagon head and sealing washer A2-WFD-4,8 x L

Material
 Fastener: stainless steel – SAE 304 bi-metal
 Washer: EPDM sealing ring with metal top made of aluminium or stainless steel
 Component I: S280GD, S320GD or S350GD – EN 10346
 Component II: structural timber – EN 14081

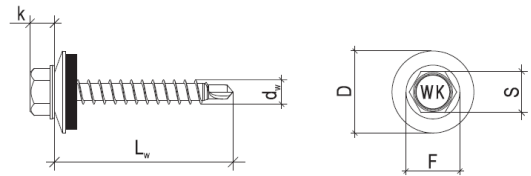

$d_w = 4,8$ mm
 $L_w = 25-100$ mm
 $s = 8$ mm
 $k = 4,5$ mm

Drilling capacity: $\Sigma t_i \leq 2,5$ mm

Timber substructures

For timber substructures performance assessed with
 $M_{y,Rk} = 4,390$ Nm
 $f_{ax,k} = 12,867$ N/mm² for $l_{ef} \geq 20$ mm
 $f_{ax,k} = 12,015$ N/mm² for $l_{ef} \geq 30$ mm

Characteristic resistance of shear and pull-out load

$t_{N,II}$ [mm]	0,50	0,55	0,63	0,75	0,88	1,00	1,25	1,50	Wood class \geq C24		*bearing resistance of component I
$M_{t,nom}$	3 Nm								20 mm	30 mm	
Resistance of shear load $V_{R,k}$ [kN] for $t_{N,I}$ [mm]	0,50	—	—	—	—	—	—	—	1,10*	1,10*	
	0,55	—	—	—	—	—	—	—	1,10*	1,10*	
	0,63	—	—	—	—	—	—	—	1,50*	1,50*	
	0,75	—	—	—	—	—	—	—	1,74*	1,74*	
	0,88	—	—	—	—	—	—	—	1,74*	1,74*	
	1,00	—	—	—	—	—	—	—	1,74*	1,74*	
	1,13	—	—	—	—	—	—	—	1,74*	1,74*	
	1,25	—	—	—	—	—	—	—	1,74*	1,74*	
	1,50	—	—	—	—	—	—	—	—	—	
	1,75	—	—	—	—	—	—	—	—	—	
	2,00	—	—	—	—	—	—	—	—	—	

DECLARATION OF PERFORMANCE No 17/SZ/16

Resistance of pull-out load $N_{R,k}$ [kN] for $t_{N,I}$ [mm]	0,50	—	—	—	—	—	—	—	—	1,24*	1,73*
	0,55	—	—	—	—	—	—	—	—	1,24*	1,73*
	0,63	—	—	—	—	—	—	—	—	1,24*	1,73*
	0,75	—	—	—	—	—	—	—	—	1,24*	1,73*
	0,88	—	—	—	—	—	—	—	—	1,24*	1,73*
	1,00	—	—	—	—	—	—	—	—	1,24*	1,73*
	1,13	—	—	—	—	—	—	—	—	1,24*	1,73*
	1,25	—	—	—	—	—	—	—	—	1,24*	1,73*
	1,50	—	—	—	—	—	—	—	—	—	—
	1,75	—	—	—	—	—	—	—	—	—	—
	2,00	—	—	—	—	—	—	—	—	—	—
	*bearing resistance of component II										

Self-drilling screws with hexagon head and sealing washer A2-WFD-5,5 x L

Material

Fastener: stainless steel – SAE 304 bi-metal

Washer: EPDM sealing ring with metal top made of aluminium or stainless steel

Component I: S280GD, S320GD or S350GD – EN 10346

Component II: structural timber – EN 14081

Drilling capacity: $\Sigma t_i \leq 2,5$ mm

Timber substructures

For timber substructures performance assessed with

$M_{y,Rk} = 4,390$ Nm

$f_{ax,k} = 12,867$ N/mm² for $l_{ef} \geq 20$ mm

$f_{ax,k} = 12,015$ N/mm² for $l_{ef} \geq 30$ mm

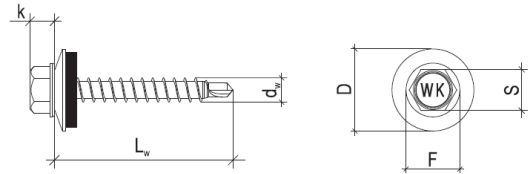

$d_w = 5,5$ mm
 $L_w = 25-100$ mm
 $s = 8$ mm
 $k = 4,5$ mm

Characteristic resistance of shear and pull-out load

$t_{N,II}$ [mm]	0,50	0,55	0,63	0,75	0,88	1,00	1,25	1,50	Wood class \geq C24		
$M_{t,nom}$	3 Nm								20 mm	30 mm	
Resistance of shear load $V_{R,k}$ [kN] for $t_{N,I}$ [mm]	0,50	—	—	—	—	—	—	—	1,10*	1,10*	
	0,55	—	—	—	—	—	—	—	1,10*	1,10*	
	0,63	—	—	—	—	—	—	—	1,50*	1,50*	
	0,75	—	—	—	—	—	—	—	1,74*	1,74*	
	0,88	—	—	—	—	—	—	—	1,74*	1,74*	
	1,00	—	—	—	—	—	—	—	1,74*	1,74*	
	1,13	—	—	—	—	—	—	—	1,74*	1,74*	
	1,25	—	—	—	—	—	—	—	1,74*	1,74*	
	1,50	—	—	—	—	—	—	—	—	—	
	1,75	—	—	—	—	—	—	—	—	—	
	2,00	—	—	—	—	—	—	—	—	—	
	*bearing resistance of component I										

DECLARATION OF PERFORMANCE No 17/SZ/16

Resistance of pull-out load N _{R,k} [kN] for t _N [mm]	0,50	—	—	—	—	—	—	—	—	1,24*	1,73*	*bearing resistance of component II
	0,55	—	—	—	—	—	—	—	—	1,24*	1,73*	
	0,63	—	—	—	—	—	—	—	—	1,24*	1,73*	
	0,75	—	—	—	—	—	—	—	—	1,24*	1,73*	
	0,88	—	—	—	—	—	—	—	—	1,24*	1,73*	
	1,00	—	—	—	—	—	—	—	—	1,24*	1,73*	
	1,13	—	—	—	—	—	—	—	—	1,24*	1,73*	
	1,25	—	—	—	—	—	—	—	—	1,24*	1,73*	
	1,50	—	—	—	—	—	—	—	—	—	—	
	1,75	—	—	—	—	—	—	—	—	—	—	
	2,00	—	—	—	—	—	—	—	—	—	—	

8. Appropriate Technical Documentation and/or Specific Technical Documentation: **not applicable**

The performance of the product identified above is in conformity with the set of declared performance/s. This declaration of performance is issued, in accordance with Regulation (EU) No 305/2011, under the sole responsibility of the manufacturer identified above.

Signed for and on behalf of the manufacturer by:

Kuźnica Kiedrzyńska
 24.08.2016r.
 (place and date of issue)

Adam Szczepanowski
 DORADCA TECHNICZNY

mgr inż. Adam Szczepanowski
 - 333 -

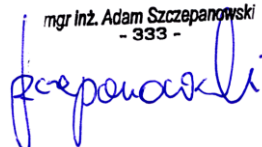

(signature)