

Runyes[®]

FOCUS ON DENTAL.

Small steam sterilizers

Operation manual

Technical manual



CE
0123

Dear Runyes Customer!

Welcome to Runyes and thank you for your purchase! Ningbo Runyes Medical Instrument Co., Ltd. is a professional dental equipment manufacturer, headquartered in Ningbo, China.

The mission of Runyes Medical is to produce dental equipment that meet the highest standards of performance and reliability. Strict quality control is enforced during manufacturing of our dental equipment.

We hope you enjoy our product. If you have any questions, comments, or special requests, please contact Runyes medical,our authorized agents or representatives.

Best regards!

Xu BuGuang, President/CEO

Ningbo Runyes Medical Instrument Co., Ltd.

032 Building, No. 456, Tonghui Road, Jiangbei

Investment & Pioneering Park C, 315033,Ningbo, China

Phone: +86 574 2770 9922

Email: runyes@runyes.com

Web: <http://en.runyes.com/>

User Registration

On the inscription plate at back of the machine, you may find the unit's model number, serial and reference number. Please double check the number and fill in the form with them, you should quote the reference number when you are in contact with your distributors.

Product name :	[_____]
Product Model:	
Serial number:	
Date of manufacture:	
Voltage:	

*Before operating the sterilizer, please read carefully all safety cautions and instructions of operation. This operator's manual will help you understand all functions of Runyes Autoclaves as far as possible.

*Please follow carefully instructions in this operator's manual While servicing and maintaining the units.

*Please keep this manual safe for your future references.

*When error occurs during operation of the machine, please get in touch with your local distributor or us for our best qualified services and assistance.



Contents

1. Introduction	1
1.1 Intended use	1
1.2 Reference standards	1
1.3 The requirements for the user	1
1.4 Product performance, structure and compose	1
1.5 Contraindications	1
1.6 Product life cycle	1
1.7 Safety elements introduction	1
2. Symbols, Sticker and Warning.	2
2.1 Symbols	2
2.2 Sticker introduction	2
2.3 Warnings	3
3. Processing principle and product structure	4
3.1 Processing principle	4
3.2 Product structure	4
3.3 Specifications	5
4. Operation interface introduction	6
5. System parameter setting	7
5.1 Setting	7
5.2 Chart for setting	9
5.3 Parameter display figure	10
6. Steam Sterilization cycle introduction	11
6.1 Sterilization cycle	11
6.2 Cycle Detail introduction	12
6.3 Display information for each cycle	15
7. Sterilization cycle parameter setting	16
7.1 Cycle introduction.....	16
7.2 Definition	16
8. Installation	17
8.1 Environment for installation	17
8.2 Waste water tank place requirement	18
8.3 Working conditions	18
8.4 Power supply:	18
8.5 Water Supply	18
8.6 Open the package and checking	18
8.7 Installation	19
8.8 Door Adjustment	20

9. Sterilization operation steps	20
9.1 Clean the materials	20
9.2 Seal the materials	21
9.3 Turn on the autoclave	21
9.4 Open door	21
9.5 Material loading	21
9.6 Close the door	21
9.7 Program choosing	22
9.8 Start cycle	23
9.9 Start sterilization	23
9.10 Sterilization ending	23
9.11 Stop sterilization	23
9.12 Attention during the sterilization operation	23
9.13 Instruments storage	23
10. Date output	24
10.1 Printer	24
10.2 Printer installation	24
10.3 Printing information	25
10.4 USB Output	25
11. Daily maintenance and safeguard	26
11.1 Cleaning water tank	26
11.4 Motherboard fuse replacement	28
11.5 Cleaning the door gasket regularly	28
11.6 Replace the door gasket	28
11.7 Safety valve inspection and replacement	29
11.8 Battery Replacement	29
11.9 Clean the whole machine	29
12. Malfunction analysis	31
12.1 Most frequently encountered failure:	31
12.2 How to handle with the sterilizing items when the autoclave is suddenly power of	32
13. Transportation and storage	33
14. Waste disposal	33
Appendix 1 Schematic diagram	34
Appendix 2 Pipeline diagram	35
Appendix 3 Pressure steam sterilizer operation instructions	37
Appendix 4. Emergency Opening Method for Door Failure	38

1. Introduction

1.1 Intended use

For medical department and biology department, the product is used for surgical instruments, medical invasive instruments, dental instruments, medical glassware and medical injection units which can be high temperature and high pressure sterilized.

1.2 Reference standards

MDD 93/42/EEC amended by 2007/47/EC

IEC61010-1:2019

IEC61010-2-040:2015

EN13060:2018

EN61326:2013

1.3 The requirements for the user

The operator must be trained how to operate this product, and well know the related sterilization knowledge.

1.4 Product performance, structure and compose

The product is composed by water tank, sterilization chamber, thermal-protective coating, door group, solenoid valve, vacuum pump, piping system, electrical system, main board, control board and shell. It has two working program 121°C and 134°C. The safety valve work at 0.27 MPa±0.01 MPa. The product will show the pressure data, tolerance is ±0.01 MPa. Can set the sterilization and drying time, tolerance is ±10%.

1.5 Contraindications

N/A.

1.6 Product life cycle

Sterilization chamber is designed for 8 durable years.

1.7 Safety elements introduction

The product is equipped with the following safety elements:

Over-temperature protector: Steam generator and Chamber both has over-temperature protector.

Door safety system: Motorized door, the product will work only when the door is 100% closed. Door can't be opened while there is pressure inside chamber or no power supply.















Automatic release safety valve: Safety valve will release the pressure when the pressure over the setting data.

Electrical safety system: Over current protecting for DC circuit, short- - circuit protecting for AC circuit.



2. Symbols, Sticker and Warning.

For safety issue, please refer to the following symbols and sticker.

2.1 Symbols

#	Symbols	Deinitions	#	Symbols	Deinitions
1		Stand By	9		Product fullill WEEE directive
2		Grounding	10		Note, refer to operation manual
3		AC circuit	11		Fragile, Handle with Care
4		Dangerous voltage	12		Keep Dry
5		Fuse	13		Manufacturing date
6		Be careful of Hot	14		Serial no.
7		USB Port	15		Drain out
8		Printer Port			

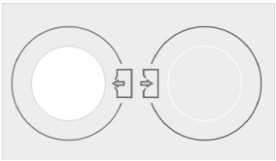
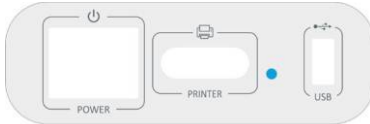
2.2 Sticker introduction

Draining label	Power switch sticker	Hot warning label
		
Water-out label		
		

2.3 Warnings

2.3.1 Please follow the instruction manual for all operations.

2.3.2 Please make sure keep the manual in a safe place during the life cycle period, Keep safe all the updated information as well. When the product need to be moved to other place. Don't forget to bring the manual as well.

2.3.3 In order to reach the sterilization requirements, please use distilled water only. (Refer to Chapter 8 for Water quality requirements). If unqualified water is illed, the product will make warning, you need to change the water.

2.3.4 This product can't sterilize the sealed liquid.

2.3.5 This product can't sterilize the halogenic medium which contain chloride ion, or corrosive medium, such as: detergent, 84 NaClO etc.

2.3.6 Chloride ion is a very important fact that will harm the stainless steel. If the sterilized articles have the halogenic medium or corrosive medium, must clean chamber by clean water after sterilization. Otherwise, it will harm the chamber, affect the product life cycle.

2.3.7 The product only can sterilize the medical articles which have high temperature resistance and high pressure resistance, can't sterilize oils articles such us Vaseline or powder articles.

2.3.8 When you see any symbols on the product, please refer to operation manual for detail information, to avoid any potential dangerous.

2.3.9 When you see the symbol , mean in this area the temperature is very high, don't touch it.

2.3.10 Instruments without package should be used immediately or stored/transported in cleaning environment after sterilized, to avoid contamination.

2.3.11 Pay attention to your local atmosphere before using device! If your local atmosphere is below 0.095pa (or altitude is higher than 500m), please contact our reprehensive in your local to re-set parameters.

2.3.12 The product' s rating voltage is 230V ~ 50/60Hz, power supply need to have 1800VA,grounding safely.

2.3.13 If the power cord broken, only professional engineer can change this.

2.3.14 Don't plug or unplug the power cord with wet hand.

2.3.15 Don't place the autoclave in an unstable place.

2.3.16 Don't cover the door, ventilation opening and thermal ventilation opening.

2.3.17 Don't put any articles or liquid on top of product.

2.3.18 If you don't use the product for long time, please unplug the power cord, clean and dry the chamber, and drain all the water out from clean tank.

2.3.19 This product should be good grounding measures.

2.3.20 Don't try to open the door during the sterilization cycle.

2.3.21 Don't turn of the power when the product is running.

2.3.22 Don't try to open door without press the OPEN DOOR button.

2.3.23 Don't place any item on top of device.

2.3.24 Keep the product away from the lammable articles.

2.3.25 Have someone monitor the product when it is working.

2.3.26 During processing, don't let the safety valve face to people.

3. Processing principle and product structure

3.1 Processing principle

According to sterilization process, firstly empty the air sterilization chamber, add wet steam into chamber, with high temperature, high pressure and high humidity, keep the pressure and temperature in a specific condition to achieve the sterilization process for the articles which need to be sterilized.

All the process parameter with the specific load, tested with the Thermophilic Bacillus bacteria or microbial fatty liver same performance under specific resistance (see in particular GB18281 and other relevant national standards) which is treated as representative of microorganisms, include bacteria gamma.

3.2 Product structure

The product is composed by chamber, control system, circuit system, water/air piping system, and shells etc.

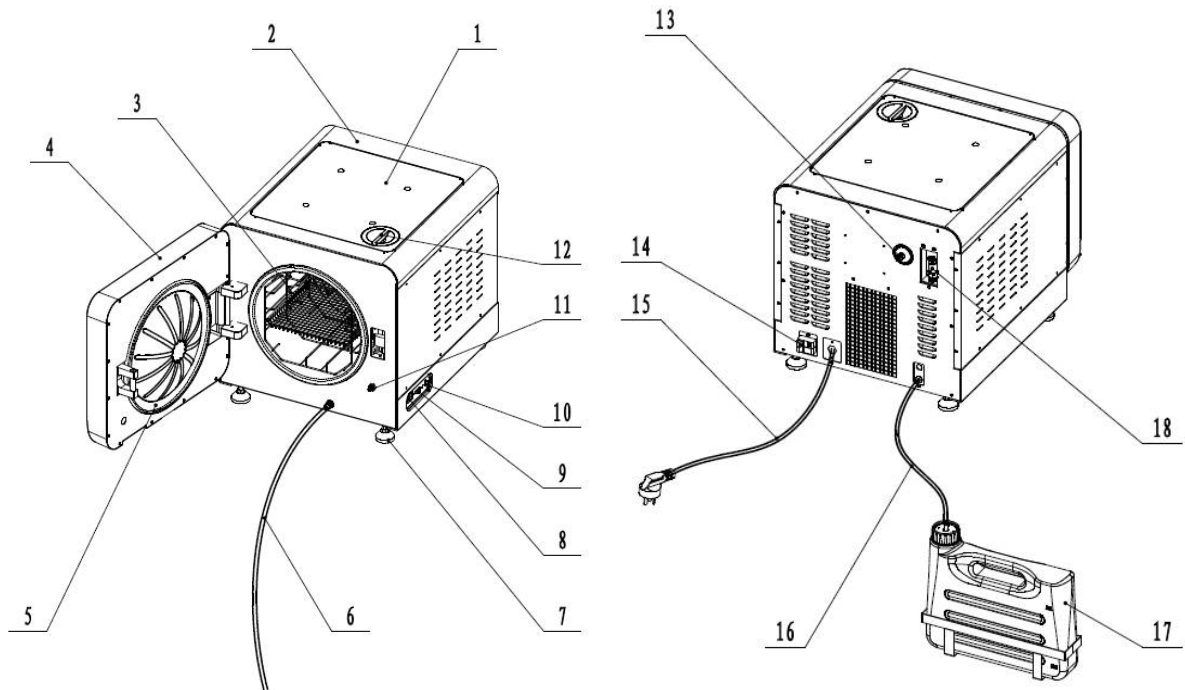

No.	Part Name	No	Part Name	No	Part Name	No	Part Name
1	Tank cover	6	Draining pipe	11	Limited Switch	16	Fuse
2	Water tank	7	Adjustable pad	12	water inlet	17	Used water tank
3	Trays and Rack	8	Switch	13	Air filter	18	Safety valve
4	Door group	9	Printer Port	14	Circuit breaker		
5	Gasket	10	USB Port	15	Power cord		

3.3 Specifications

NO.		SEA29	SEA45
1	Overall size (L*W*H) mm	665*536*506	865*536*506
2	Chamber size(mm)	Φ319*420	Φ319*620
3	Chamber capacity (L)	29L	45L
4	Product classification	B	B
5	Rating voltage	230V ~ 50/60Hz	230V ~ 50/60Hz
6	Input power (VA)	3300VA	3300VA
7	Design pressure (MPa)	-0.1/0.3MPa	-0.1/0.3MPa
8	Design temperature (°C)	140°C	140°C
9	Temperature display accuracy (°C)	0.1°C	0.1°C
10	Pressure display accuracy (KPa)	1Kpa	1Kpa
11	Fuse parameter	F20AL250V	F20AL250V
12	Water tank capacity(L)	10L	10L
13	One cycle water consumption (mL)	700 ml	800 ml
14	Environment temperature (°C)	+5°C~ 40°C	+5°C~ 40°C
15	Relative humidity range	≤85%	≤85%
16	Net weight (Kg)	80 Kg	105 Kg
17	Max load (Kg)	86.5Kg	115 Kg

Max load for one cycle:

Type	Max load for instrument	Max load for fabrics	Max load for single package
SEA29	6.5kg	3.5kg	2.5kg
SEA45	10.5kg	5kg	3kg

4. Operation interface introduction

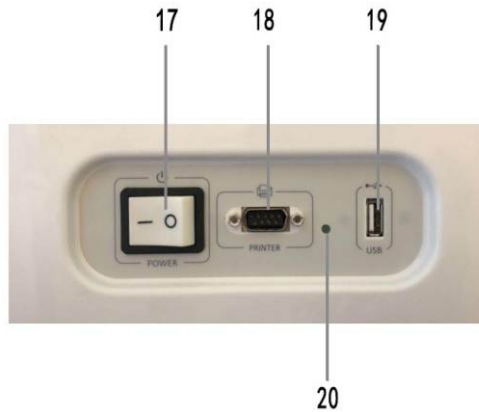
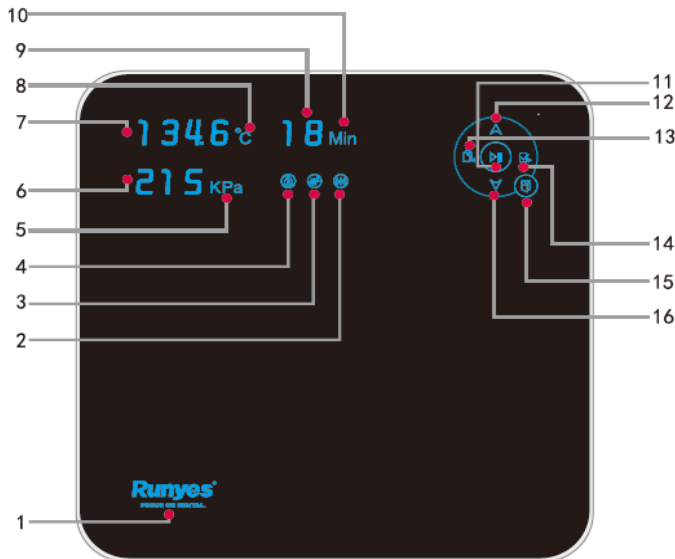

No.	Deinition	Description
1	Trade mark	Runyes
2	Inadequate water	Light on: Inadequate water of clean water tank Light Off: Adequate water of clean water tank
3	Cycle processing	Light on: Sterilization cycle processing Light off: Sterilization cycle end
4	Locked	Light on: Door locked Light off: Door open
5	Pressure unit	Chamber pressure unit KPa
6	Pressure display	Chamber pressure during cycle processing



7	Temperature display	Chamber temperature during cycle processing
8	Temperature unit	Chamber temperature unit 0C
9	Time display	Showing the rest sterilization time. If the rest time is >1minute, it will show minute. If the rest time is <1minute, it will show second.
10	Time unit	Minute
11	START/STOP	Sterilization cycle Start or Stop
12	Up	Only for specification adjustment, details need to follow up "Specifications setup"
13	Menu	Choose sterilization cycle Specification adjustment, details need to follow up "Specifications setup"
14	Conirm	1.Conirm sterilization cycle 2. Specification adjustment, details need to follow up "Specifications setup"
15	Open door	Open door
16	Down	Only for specification adjustment, details need to follow up "Specifications setup"
17	Power switch	1.Light on: power connected 2.Light off: power disconnected
18	Printer port	Connect Micro-printer
19	USB port	Connect USB memory
20	Power switch indicator light	Indicating whether the power is well connected
21	USB port indicator light	Indicating the data is transferring.

5. System parameter setting





5.1 Setting





System setting is basically for time and printing setting.





Follow the steps as below:





- 1.Turn on power switch, autoclave stand by;
2. Keep pressing “” for 5 seconds , enter into parameter setting, the default setting is “YEAR setting”;
3. Repeat press “” , it will run “Year-Month-Date-Hour-Minute-Print-Exit” circularly.





Detail information about each parameter:

1>Enter into YEAR setting, press “” conirm , The YEAR is shining (for instance “16” is shining) , Press “”or “”set YEAR , after setting, press “”conirm , will have 4times “DI” alarming;

2>Enter into MONTH setting, press “” conirm , The MONTH is shining(for instance “04” is shining), Press “”or “”set MONTH , after setting, pres “” conirm , will have 4times “DI” alarming;

3>Enter into DATE setting, press “”conirm, the DATE is shining(for instance 07 is shining), Press “”or “”set date , after setting press “”conirm , will have 4 times “DI” alarming;

4>Enter into MINUTE setting, press “”conirm, the MINUTE is shining(for instance 30 is shining), Press “”or “”set MINUTE , after setting press “”conirm , will have 4times “DI” alarming;

5>Enter into PRINTING setting, press “”conirm , Printing information is shining (for instance “ON” is shining), Press “”or “”set printing , after setting press “”conirm , will have 4times “DI” alarming;

“ON” means printing on;

“OF” means printing on;

6>Exit setting, press “”conirm to save and exit.

5.2 Chart for setting

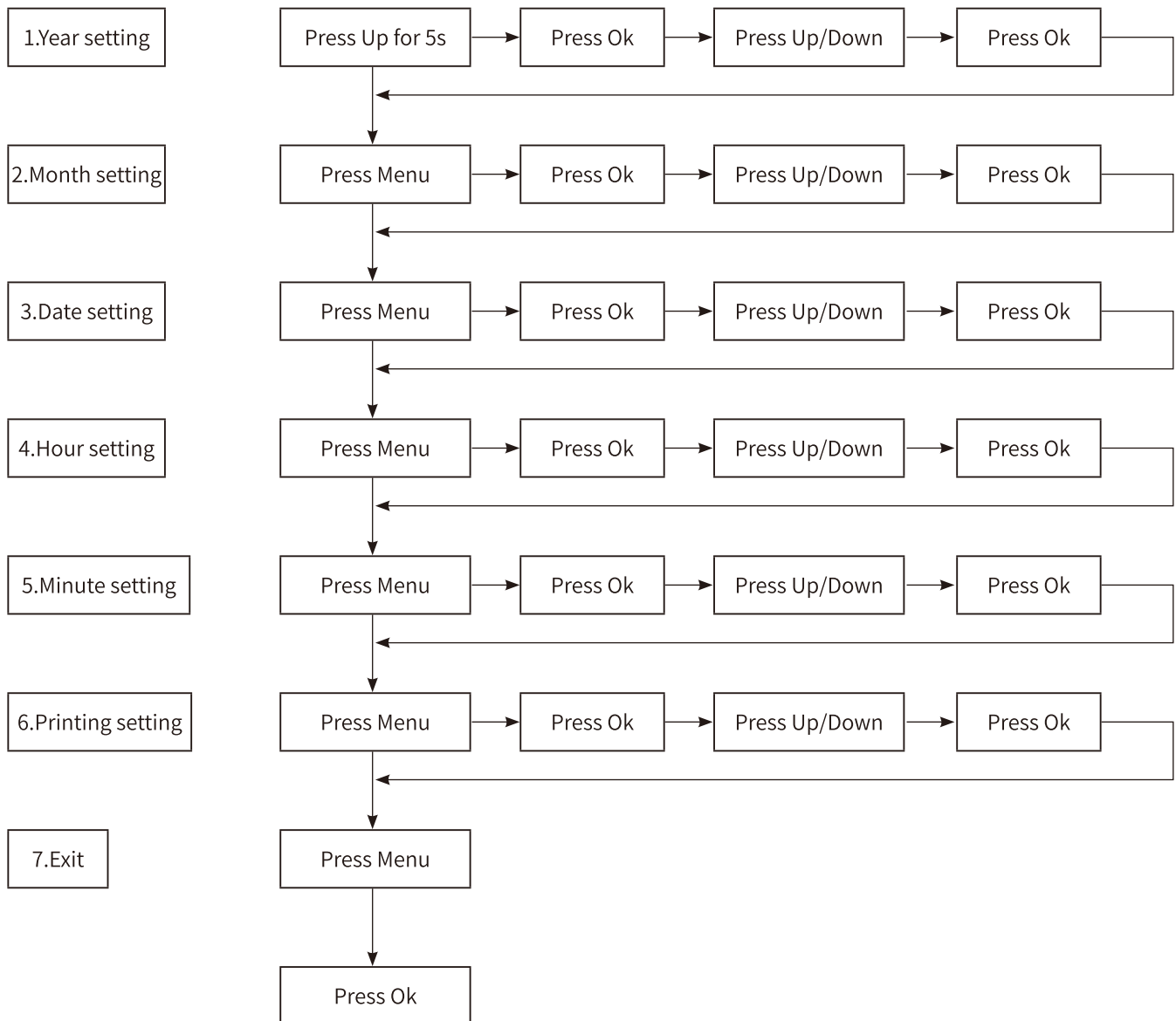

5.3 Parameter display figure



Item No	Status	Display figure
1	Standby	<div style="border: 1px solid black; padding: 5px; text-align: center;"> - - - - °C - - Min 0 KPa </div>
2	Year setting	<div style="border: 1px solid black; padding: 5px; text-align: center;"> YE r _ °C 16 Min 01 KPa </div>
3	Month setting	<div style="border: 1px solid black; padding: 5px; text-align: center;"> n t H _ °C 04 Min 02 KPa </div>
4	Date setting	<div style="border: 1px solid black; padding: 5px; text-align: center;"> d d y _ °C 07 Min 03 KPa </div>
5	Hour setting	<div style="border: 1px solid black; padding: 5px; text-align: center;"> H o r _ °C 10 Min 04 KPa </div>
6	Minute setting	<div style="border: 1px solid black; padding: 5px; text-align: center;"> n i n _ °C 31 Min 05 KPa </div>
7	Printing setting	<div style="border: 1px solid black; padding: 5px; text-align: center;"> P r t _ °C 0 n Min 06 KPa </div>
8	Exit	<div style="border: 1px solid black; padding: 5px; text-align: center;"> E i t _ °C - - Min 07 KPa </div>

6. Steam Sterilization cycle introduction

All the cycles parameter is tested under the standard load. If the load is changed by user (more load than the standard load), need to be verified by manufacturer.

6.1 Sterilization cycle

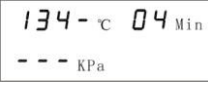
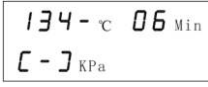
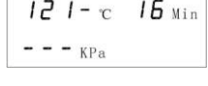
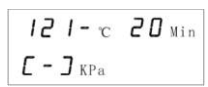
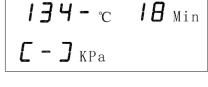
Total 7 cycles as below:

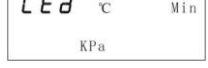
Item	Sterilization cycle mode	Display figure	Sterilization temperature	Sterilization pressure	Sterilization time	Drying time	Cycle Complete time	Load type or usage
1	Unpaged cycle		134	210	4	10	80	Apply to sterilization for the unpacked bare metal objects with high temperature resistant, such as standard load models for solid metal screws.
2	Universal B cycle		134	210	6	15	95	Apply to the sterilization for items with packages and high-temperature resistant, such as standard load simulation for metal screw with paper-plastic bag, bag cloth fabric loads
3	Rubber & Plastic cycle		121	110	16	10	90	rubber non-resistant of 134 degrees high temperature , solid or hollow items without package
4	Rubber & Plastic wrapped cycle		121	110	20	15	100	rubber non-resistant of 134 degrees high temperature , solid or hollow items, fabric without package
5	18Minutes B cycle		134	210	18	15	100	Apply to the instruments contain more difficult to kill bacteria, high temperature resistance, no package or solid with package, cavity class items, fabric
6	Sterilization result testing cycle						70	Testing for the steam penetration effect ,cold air release effect
7	Vacuum Leakage testing cycle						20	Testing for leakage

6.2 Cycle Detail introduction

1.Unpaged cycle -- Apply to sterilization for the unpacked bare metal objects with high temperature resistant,such as standard load models for solid metal screws.

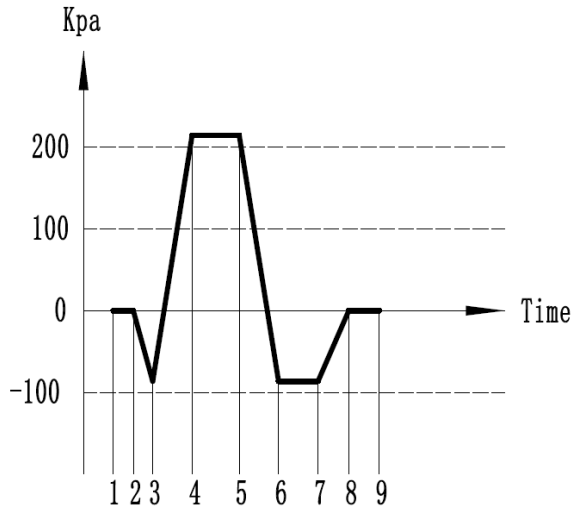

1.Start 2.preheating time 3.Vacuum time 4.Sterilizing start time 4-5.Sterilizing time
5. Sterilizing end time 6.Drying start time 7.Drying end time 8.Pressure balance time 9.End

2.Universal B cycle -- Apply to the sterilization for items with packages and high-temperature resistant, such as standard load simulation for metal screw with paper- plastic bag, bag cloth fabric loads

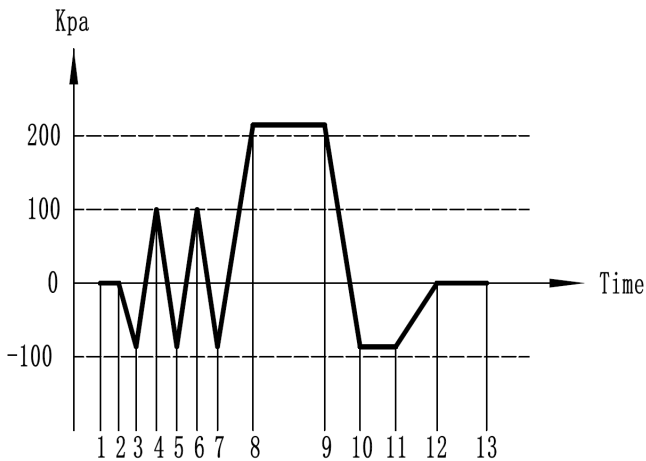

1.Start 2.Preheating time 3.Vacuum time 4. Pressure time 5.Vacuum time 6.Pressure time
7.Vacuum time 8.Sterilizing start time 8-9. Sterilizing time 9. Sterilizing end time
10.Drying start time 11.Drying end time 12.Pressure balance time 13.End

3. Rubber & Plastic cycle -- rubber non-resistant of 134 degrees high temperature, solid or hollow items without package

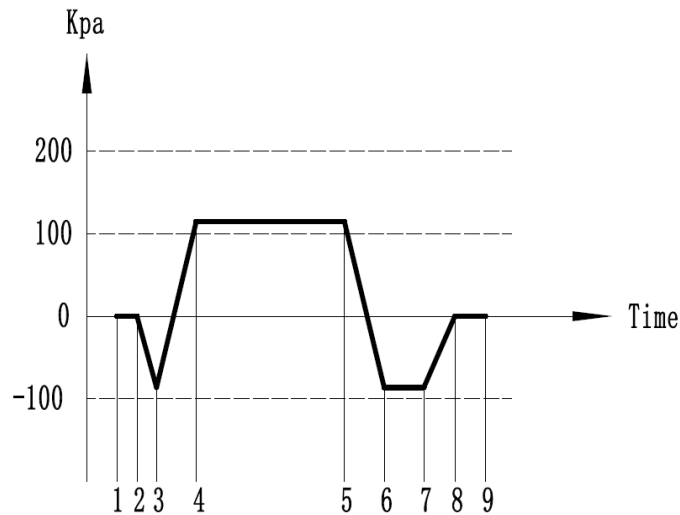

1.Start 2.preheating time 3.Vacuum time 4.Sterilizing start time 4-5.Sterilizing time
5. Sterilizing end time 6.Drying start time 7.Drying end time 8.Pressure balance time 9.End

4. Rubber & Plastic wrapped cycle -- rubber non-resistant of 134 degrees high temperature, solid or hollow items, fabric without package

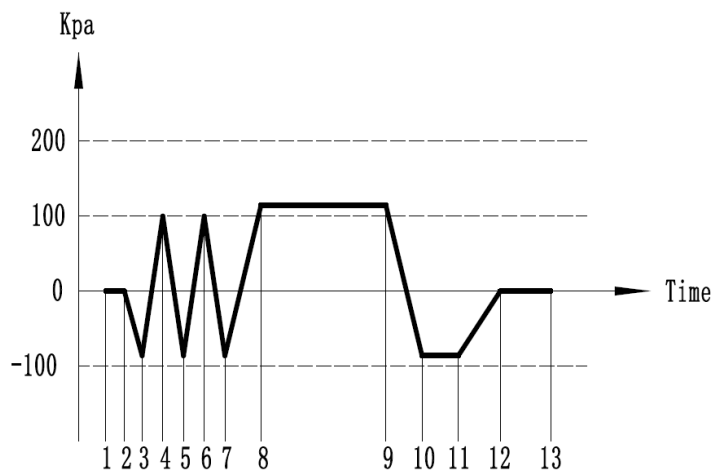

1.Start 2.Preheating time 3.Vacuum time 4. Pressure time 5.Vacuum time 6.Pressure time
7.Vacuum time 8.Sterilizing start time 8-9. Sterilizing time 9. Sterilizing end time
10.Drying start time 11.Drying end time 12.Pressure balance time 13.End

5. 18 Minutes B cycle -- Apply to the instruments contain more difficult to kill bacteria, high temperature resistance, no package or solid with package, cavity class items, fabric

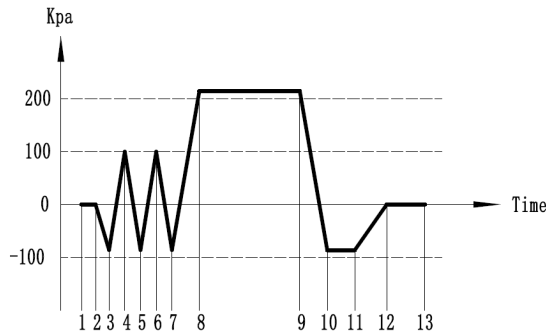

- 1.Start 2.Preheating time 3.Vacuum time 4. Pressure time 5.Vacuum time 6.Pressure time
- 7.Vacuum time 8.Sterilizing start time 8-9. Sterilizing time 9. Sterilizing end time
- 10.Drying start time 11.Drying end time 12.Pressure balance time 13.End

6. Sterilization result testing cycle -- Testing for the steam penetration effect ,cold air release effect

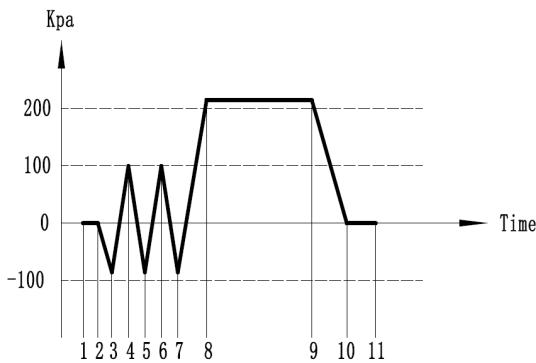





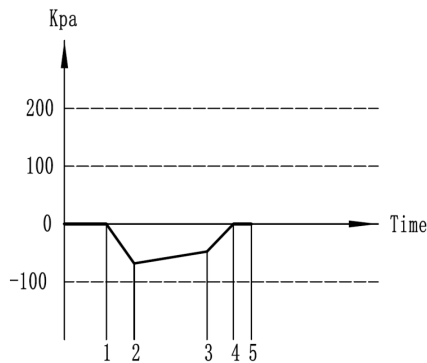











- 1.Start 2.Preheating time 3.Vacuum time 4. Pressure time 5.Vacuum time 6.Pressure time
- 7.Vacuum time 8.Sterilizing start time 8-9. Sterilizing time 9. Sterilizing end time
- 10.Pressure balance time 11.End

7. Vacuum Leakage testing cycle -- Testing for leakage



- 1.Testing start time 2.Max.pressure time 3.Testing end time 4.Pressure balance time 5.End

6.3 Display information for each cycle

Steps	Status	Display figure	Status display	Notes
1	Self-inspection	8.8.8.8 °C 8.8 Min 8.8.8 KPa	  	
2	Standby	--- °C --- Min 0 KPa		Status indicator keeps on means the door is locked, status indicator is off means the door is not locked
3	Non-Package cycle	134- °C 04 Min --- KPa		Status indicator keeps on means the door is locked, status indicator is off means the door is not locked
4	Pre-heating period	--- °C HE Min --- KPa	 	Four horizontals
5	Heating period	54.1 °C HE Min -21 KPa	 	Temperature display area, pressure display area show real-time data
6	Sterilizing period	135.8 °C 3. Min 213 KPa	 	Temperature/pressure display area show real-time data, time display area shows the remaining sterilizing time(decimal point licker when the time is more than one minute second counts when the time is less than one minute)
7	Drying period	dr- °C 3. Min -42 KPa	 	Pressure display area shows real-time data, time display area shows the remaining drying time(decimal point licker when the time is more than one minute, second counts when the time is less than one minute)
8	Pressure balance	LE- °C 23 Min 0 KPa	 	Pressure display area shows real-time data, time display area shows the remaining end time(second)
9	End	--- °C Ed Min --- KPa		

7. Sterilization cycle parameter setting

7.1 Cycle introduction

All the cycles parameter is tested under the standard load. If the load is changed by user (more load than the standard load), need to be verified by manufacturer.

Detail introduction, for instance: “UNWRAPPED CYCLE”



Steps:



1> Turn on the power switch, autoclave standby by.

2> Press “”, enter for UNWRAPPED CYCLE;



3> Keep pressing “” for 5s, enter into sterilization time setting, time display is shining.

(If quick press “”, will enter into LAST CYCLE setting.)



4> Press “” or “”, set the sterilization time; For “Unwrapped cycle, default sterilization time is no less than 4 minutes).

5> After setting, press “” confirm and save. Then system will go to next setting: drying time setting. Press display area will be shining. Or after sterilization time setting, press “” save and exit, will not go to next setting.

6> Press “” or “”, set drying time.

7> After setting, press “” confirm and save, then system will go to next setting: last cycle setting, pressure display area will have three shining lines. Or after drying time setting, press “” save and exit, will not go to next setting.

8> Press “” or “”, set the last cycle.

9> After setting, press “” confirm and save, complete the last cycle setting, exit sterilization cycles parameter setting. Or after last cycle setting, press “” save and exit.

It is same setting method for “Universal B cycle”, “Rubber & Plastic cycle”, “18MinutesB cycle”.

7.2 Deinition

Last cycle: the last cycle of sterilization, after the cycle, autoclave will cut of the heating system by program.

Non-last cycle: Not he last cycle of sterilization, after the cycle, autoclave will keep the chamber warm. In this case, will short the next cycle time.

Steps	Status	Display figure	Note
1	Standby	<div style="border: 1px solid black; padding: 5px; text-align: center;"> - - - - °C - - Min 0 KPa </div>	
2	Non-Package	<div style="border: 1px solid black; padding: 5px; text-align: center;"> 134- °C 04 Min - - - KPa </div>	
3	Sterilizing time setting	<div style="border: 1px solid black; padding: 5px; text-align: center;"> 134- °C 04 Min - - - KPa </div>	“04” blinking
4	Drying time	<div style="border: 1px solid black; padding: 5px; text-align: center;"> 134- °C 04 Min 10 KPa </div>	“10” blinking
5	The last time cycle	<div style="border: 1px solid black; padding: 5px; text-align: center;"> 134- °C 04 Min - - - KPa </div>	“---” blinking
6	Not the last time cycle	<div style="border: 1px solid black; padding: 5px; text-align: center;"> 134- °C 04 Min - - - KPa </div>	“---” blinking

8. Installation

8.1 Environment for installation

1> The requirements of install the autoclave: Need to have minimum 50mm space from each side of autoclave, to ensure enough space for hot ventilation.

2>The working plane for place the autoclave can hold minimum 60KGS.

3>The installation area for autoclave need have enough lights.

Overall size of the machine as below:

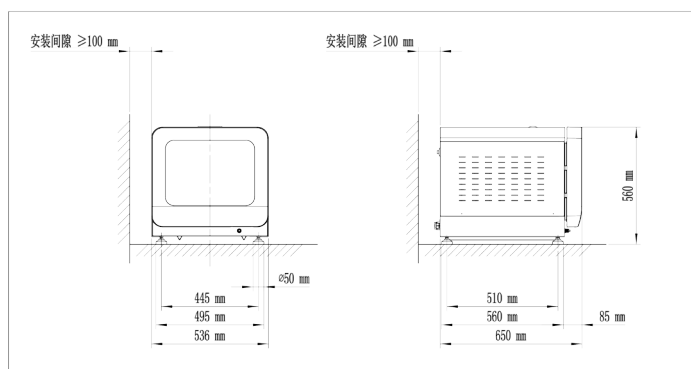
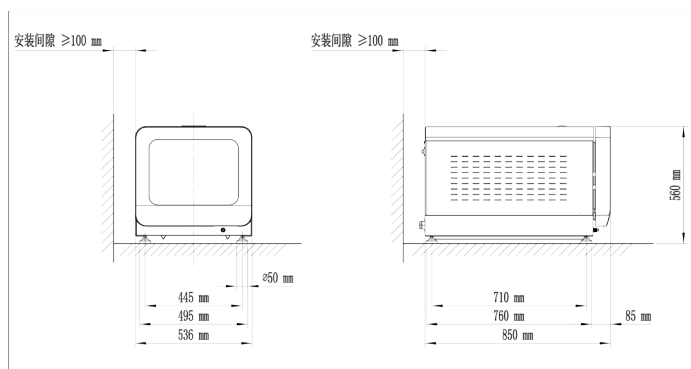

8.2 Waste water tank place requirement

- 1> Waste water tank can't be placed higher than draining port.
- 2> Waste water tank need to be placed in some area which can be obviously seen.

8.3 Working conditions

- 1>Environment temperature: 5°C --40°C .
- 2>Relative humidity: ≤ 85%.
- 3.Atmosphere:70kPa--106kPa.

8.4 Power supply:

- 1>The rating voltage of the product is 230 ~ 50/60 Hz. The power supply circuit can withstand 1800VA.
- 2> The product must be grounding reliably.

8.5 Water Supply

The product with built-in clean water tank, no need to connect outsource water.
 The water quality must be following the below chart:

	Water supply	Condensate
evaporation residue	≤10mg/l	≤1.0mg/kg
SiO2	≤1mg/l	≤0.1mg/kg
Fe	≤0.2mg/l	≤0.1mg/kg
Cd	≤0.005mg/l	≤0.005mg/kg
Pb	≤0.1mg/l	≤0.1mg/kg
Other heavy metal	≤0.1mg/l	≤0.1mg/kg
chloride	≤2mg/l	≤0.1mg/kg
phosphate	≤0.5mg/l	≤0.1mg/kg
Electrical conductivity(20°C)	≤15us/cm	≤3us/cm
PH	5-7.5	5-7.5
Appearance	Colorless clean no precipitation	Colorless clean no precipitation
Hardness	≤0.02mmol/L	≤0.02mmol/L

8.6 Open the package and checking

- 1>The product has two separate package, the big one is for autoclave itself, the small one is for waste water tank.
- 2> Remove the carton cover, and side piece, remove the PE, take out the autoclave from the package, remove the plastic bag.
- 3>Keep all the package material a good condition for future use.
- 4>Check all the information on the nameplate, compare with your order detail.
- 5> Check all the appearance, if any scratch or broken parts is ind, please contact us with transportation information.
- 6> Check all the accessories with the product. If any thing missing, please contact us.

8.7 Installation

Warning for moving the product:

- 1> Can't hold on the door.
- 2> Can't hold the autoclave pad only.
- 3> Don't sidelong or upturn the product.

Correct area for holding the product as below:

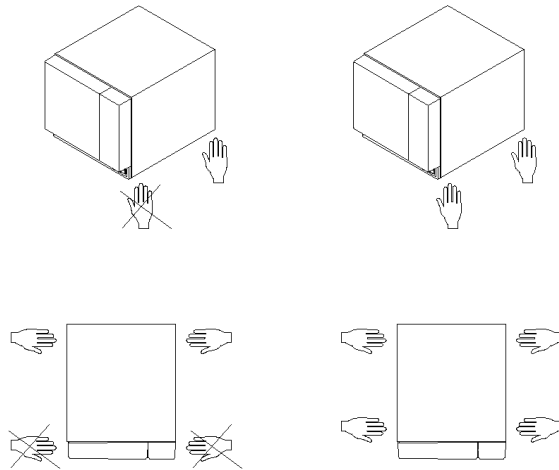

Installation:

- 1> Place the product in the specified place.
- 2> After placed the autoclave on the working plane, adjust the adjustable pad, make sure front of autoclave is higher than back of the autoclave.
- 3> Connect power supply. Connect the power cord from the autoclave, Brown wire connect with power circuit firing wire, Blue wire connect with power circuit zero wire, Yellow/green wire connect with grounding wire.

Note: Must be operated by professional electrical engineer.

- 4> Add clean water: open the water tank cover by turning the screws, add clean water into water tank, do not over the warning line, see below:

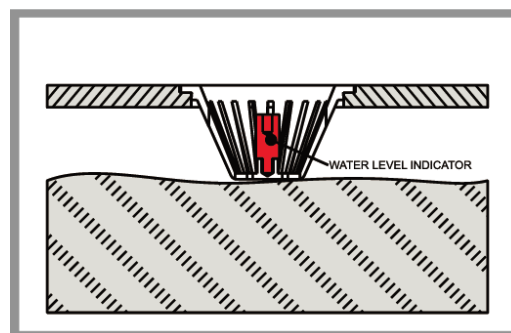

Warning line

5>Turn on the product. After connected with power supply, turn on the power switch, the power indicator is on, mean power connected well. Product run self-checking, with “DI” buzze. After checking, the product will be stand by.

6>Open the door. As the product is motorized autoclave, just press “”, the door will be opened.

7>Take out all the accessories inside of chamber, save it well for future use.

8.8 Door Adjustment

Normally, door sealing is adjusted in best condition before selling. If any leak found during working, please follow below steps to adjust:

1> Open the door, through adjusting tie rod, located inside door cover, could be seen from bottom window of door cover.

2> Pull down the tie rod, meantime, turn the sealing cover to some angle, not too much.

3> Loose tie rod, then continue to turn sealing cover slightly till tie rod automatically back to lock sealing cover, then adjustment is done.

Caution: Do not make sealing cover too loose, it may cause steam leakage when sterilization.

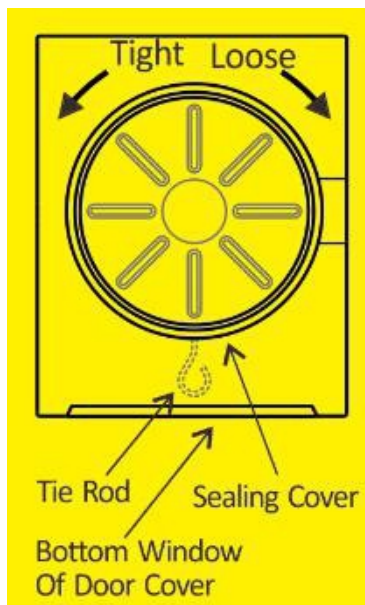

Bottom window of door cover

9. Sterilization operation steps

9.1 Clean the materials

Clean the instruments after surgical operation, and disposal the residues. We suggest you clean the instruments by Ultrasonic cleaner, cleanser or free mineral water. After cleaning, rinse the instruments, seal by sealing machine waiting for sterilization. Or load unwrapped instruments directly on the tray for immediate sterilization.

9.2 Seal the materials

1. You need to choose different sterilization roll depend on the storage time for instrument.

Note: Sterilization roll must fulfill the GB/T19633 standard. Sterilization roll for textile should be non-bleached fabric. High temperature washing, degreasing and remove the paste, remove the color is needed for first time using, and should record it.

2. When seal the materials, separate the dressings and instrument, inverted the plate, basin to avoid water inside. If stack all the plate/basin together, put absorbent paper between each plate/basin. All the other materials, please refer to related standard.

3. When you seal the material, make sure all the material facing same direction, and can't move after sealed.

4. Single package weight can't exceed the weight which single tray can load. The max weight of rack can load is the max instrument type weight.

Max load for one cycle:

Type	Max load for instrument	Max load for fabrics	Max load for single package
SEA29	6.5kg	3.5kg	2.5kg
SEA45	10.5kg	5kg	3kg

9.3 Turn on the autoclave

Before use the autoclave, make sure power is well connected. Connect the draining port and waste water tank. Turn on the switch, power indicator is on, mean power is connected. Autoclave run self-checking with "DI" buzzle. After self-checking, it is ready for work.

9.4 Open door

The autoclave is motorized door system, press “” to open the door.

9.5 Material loading

After open the door, put all the trays with material into the chamber.

Warning for loading:

1>Material can't touch the chamber.

2> Any kind of pipe, make sure the two sides are open, no bending or twisting.

3> All the instruments, the open side need to be placed inverted or sidelong, avoiding any water there.

4> All the instruments should be loaded uniformity. There is space between each instrument. Don't stack in one area.

5>Diferent type of instruments need to be loaded on diferent tray.

6> Load the rack with trays into the chamber, close the door cover.



According to the sterilization requirements of diferent category articles, choose the related sterilization cycle.(You can refer to the cycle detail information).







9.6 Close the door

When you are closing the door, the internal motorized door system will trigger the locking system, door will be closed automatically. If you release the door during closing period, the locking system will stop

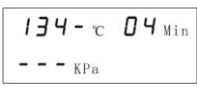
and exit the locking status. The "  "on, means door locked.

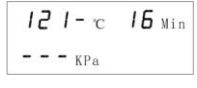
9.7 Program choosing

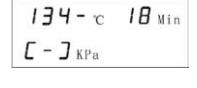
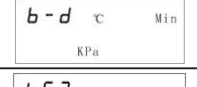
Press "  ", choose program, press "  " to confirm. Below you will find the sterilization cycles:

Item	Sterilization cycle mode	Display figure	Sterilization temperature	Sterilization pressure	Sterilization time	Drying time	Complete time	Load type or usage
1	Unpaged cycle		134	210	4	10	40	Apply to sterilization for the unpacked bare metal objects with high temperature resistant, such as standard load models for solid metal screws.
2	Universal B cycle		134	210	6	15	55	Apply to the sterilization for items with packages and high-temperature resistant, such as standard load simulation for metal screw with paper-plastic bag, bag cloth fabric loads
3	Rubber & Plastic cycle		121	110	16	10	50	rubber non-resistant of 134 degrees high temperature, solid or hollow items without package
4	Rubber & Plastic wrapped cycle		121	110	20	15	65	rubber non-resistant of 134 degrees high temperature, solid or hollow items, fabric without package
5	18Minutes B cycle		134	210	18	15	65	Apply to the instruments contain more difficult to kill bacteria, high temperature resistance, no package or solid with package, cavity class items, fabric
6	Sterilization result testing cycle						30	Testing for the steam penetration effect, cold air release effect
7	Vacuum Leakage testing cycle						20	Testing for leakage

9.8 Start cycle

Choose the cycle, press “  ” to start cycle.

Note: During the process, the operator doesn't go far away the machine. Need to monitor the process. If any exceptional conditions happened, please exit the program or cut of the power directly.

Before start the cycle, the product will check whether it has enough water. If there is inadequate water inside the water tank, product will make “Di-Di-Di” noise to remind you add water. Distilled water is the only choice for this product. Don't exceed the max. water level when you adding water.

9.9 Start sterilization

The product is automated intelligent machine, no operation is needed during the sterilization cycle. Details refer to chapter 6.

9.10 Sterilization ending

After sterilization end, press “  ” open the door, unload the instruments.

Note: After open the door, don't touch the hot temperature part such as door cover, door plate. Use the door spanner to get the tray out.

9.11 Stop sterilization

During the sterilization cycle, if you press “  ” for 3seconds, you will stop the sterilization cycle.

If you stop the cycle before the drying period, the product will still run 3minutes drying time to complete the cycle. If you press “  ” for another 3seconds, then will end directly.

If you stop the cycle during the drying time, it will end directly.

If the instruments did not be sterilized by whole cycle, can't be used.

9.12 Attention during the sterilization operation

1>After sterilization cycle, chamber/door cover/instruments racks/instrument tray are very hot. To avoid injury, we suggest to use the tray spanner to take the trays out.

2> Don't open the door until the pressure shows 0 KPa.

3> Suggest to put sterilization testing strip or sterilization roll which can show the sterilization result, to check the reliability of the autoclave.

9.13 Instruments storage

Sterilized instruments should be stored in warehouse which is sealed dust-free, dry, stable environment temperature.

Storage time:

The storage of sterilized instruments is associated with the type of packing material, and packaging. Unpackaged sterilized instruments should be used immediately.

Package material	Storage time	Note
Fabrics packaging material	14days	If the storage condition is not fulfill the re - quirement (environment temperature <24°C environment humidity <70%), the storage time only 7days.
Medical disposable paper bags	1month	
Medical disposable crepe paper bags	6monthes	
Medical non-woven fabrics	6monthes	
Medical disposable plastic bags	6monthes	
Rigid containers packing	6monthes	

10. Date output

10.1 Printer

Depend on customer's request, micro-printer is an optional.

Note:

The product only compatible with our micro-printer.

It should be connected before sterilization cycle.

Make sure the printer has adequate printing paper inside.

10.2 Printer installation

Following the steps for installation:

Connect the printer with the printer cord which is come together with printer, as below figure;

Turn on autoclave' s power switch;

It is connected well when the printer' s lights are on.

Printer setting, Details please refer to Chapter 5 for“ Printing setting”.



Print out

The default setting of printer is on, when the cycle complete, it will automatically print out the record. If you want to reprint the cycle, when the autoclave is standby, press"  " for 3 seconds, it will reprint the current sterilization cycle.

Note: If autoclave is turned of or start a new cycle, the previous cycle can ' t be printed.

10.3 Printing information

Print information

Date: Date
 S/N: Serial No(**default is close the function**)
 C.N: Cycle name
 C.S.T: Cycle start time
 Vp1、Vp2、Vp3: Vacuum
 Pp1、Pp2、Pp3: Pressure strengthen
 H.S.T: Sterilization start time
 Max、Min、Ave: Max. Min and average pressure or temperature of chamber
 H.E.T: Sterilization end time
 D.S.T: Drying cycle start time
 C.E.T: Cycle end time
 Result: Result
 Operator: Operator, you can sign your name if it needed.

Sterilization Records	
Date:	Y11M05D11
Cycle:	00001
C.N.:	134 2.10
-B-SP=6mDP=10m	
C.S.T.:	13:05:30
Vp1:	13:11:27 0.00 048.9
Pp1:	13:12:57 -0.81 050.2
Vp2:	13:16:33 0.29 107.5
Pp2:	13:18:01 -0.81 072.1
Vp3:	13:20:36 0.30 112.4
Pp3:	13:22:14 -0.81 081.4
H.S.T.:	13:27:55
Max:	2.14 134.6
Min:	2.02 134.5
Ave:	2.08 134.5
H.E.T.:	13:34:06
D.S.T.:	13:34:43 0.30 115.5
C.E.T.:	13:45:32
Result:	Passed
Operator:	
Thanks	

10.4 USB Output

The product can work with extra USB disk to download the sterilization cycles.

1>The parameter of USB module.

Storage capacity: 2Mbytes.

Cycles number can be stored: 2014cycles.

Format of USB: FAT

How to use:

1>Turn on autoclave power, USB module run self-checking. After self-checking, USB indicator will lash once, USB standby.

2>Every cycle ends, product will detect USB is connected (printing parameter should be ON), will deliver the data to USB module. It will lash once again after the data received.

3>When the product is standby, insert USB disk into the USB portal, the portal indicator is on, USB disk is lashing. It is downloading the data. Don't turn of the power or take out the USB at this moment. Otherwise all the data will be lost.

4>USB module will lash twice, mean all the data is downloaded. You can remove the USB disk now.

5>During the sterilization cycle, it will cause data losing if you insert the USB disk.

6>Insert USB disk into your computer. Open the USB ile, you will ind the ile like "-200-". This is the ile for all the downloaded cycles. Open the ile, you will ind all the sterilization cycles named by YEAR/MONTH/DAY. Under the "DAY" ile, you will ind all the cycles for this day.

You can also get and manage the data from "USB data management software" (we copy this software into USB disk). You may ind the software installation and operation under the USB disk files.

7>If the USB module is faulty, the module indication will lash speciic times to show the error. Details as below:

Times	Meaning	Trouble shooting
1time	Self-Inspection pass/Data received complete	Normal
2times	Operation complete	Normal
3times	No definition	---
4times	U-key to be formatted	Format the U-Key as FAT
5times	U-key out of free space	Delete files in U-key
6times	U-key to be formatted	Format the U-Key as FAT
7times	hardware failure in USB module	Contact us

11. Daily maintenance and safeguard

Following the maintenance chart as below. All the mentioned maintenance can be done by operator if there is no specific request.

Item	Parts Name	Maintenance frequency	Maintenance requirements	Remarks
1	Chamber	Daily	Keep Clean, no dirty	
2	Chamber drain filter	Weekly	Keep Clean, no dirty	
3	Water tank	Weekly	Keep Clean, no dirty	
4	Door gasket	Weekly	Keep Clean, no dirty	
5	Water tank water filter	Weekly	Keep Clean, no dirty	
6	Instruments tray/Rack	Daily	Keep Clean, no dirty	
7	Entire machine	Weekly	Keep Clean, no dirty	

User need to consider the real conditions compare with the above maintenance schedule.

Flexibly adjust the maintenance frequency, keep the product in a better condition.

Note:

Before maintenance, turn off the power, let the product cool down and with good light.

Must run B&D testing cycle after safeguard, make sure the product is on a good performance condition.

11.1 Cleaning water tank

The water tank of autoclave need to be cleaned regularly. Detail operation as below:

1. Drain out all the water, details refer to next chapter.
2. Rotate the plastic screw on the top, open water tank cover.



3. Use the burr-free cloth, clean the water tank with alcohol, flush with clean water, drain the water out through draining connector, dry the water tank. Take the plastic water filter out, clean it. If the plastic water filter has been used for long time, or the net is broken, please replace a new one. Install the plastic water filter back to the place.

11.2 Empty water tank

Emptying the clean water tank: draining valve as shown in the figure below, insert the silicone tube (accompanied with the machine) into the drain, counterclockwise to drainage.

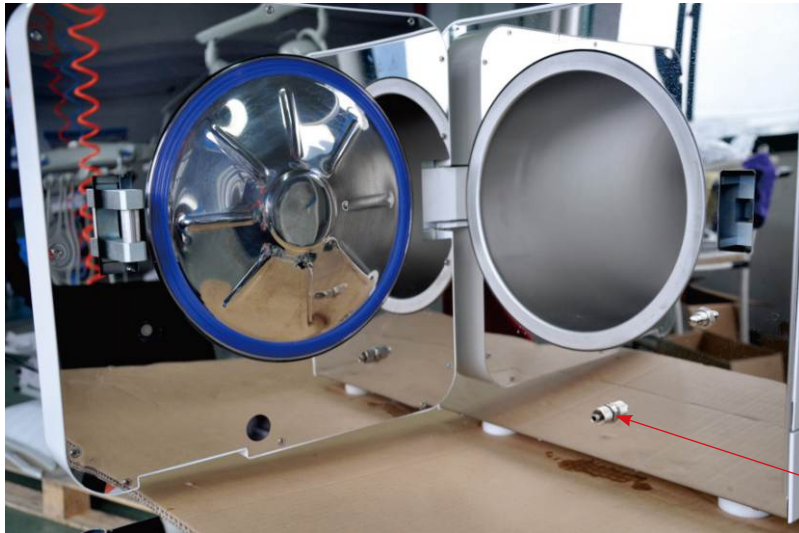

water tank draining



Draining pipe

11.3 Water draining filter cleaning

After several times use, impurities may go into the drain filter, it will affect the vacuum drying results. In order to prolong the service life of filter drainage, monthly unscrew the drain filter, remove the internal filter, using a soft brush to scrub.

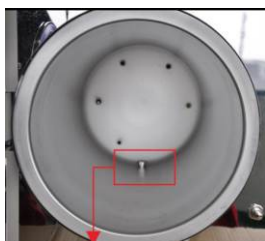

1.Chamber water filter



2.Back out the water filter



3.Take out the filter net clean it

11.4 Motherboard fuse replacement

When you replace the fuse, make sure the new fuse specifications are the same as original one:

Please take following steps:

- 1> Turn off the power
- 2> Open the right side panel with a Phillips screwdriver .
- 3> Remove the fuse from circuit board by using a knife or other tool to.
- 4> Install the same specs fuse.
- 5> Install the right side panel with a Phillips screwdriver.

11.5 Cleaning the door gasket regularly

The surface for the door gasket may have some scale or some other impurities built-up after some time of use, which may affect the performance of the autoclave, so regular cleaning is necessary.

Take the following steps:

Use the Burr-free cloth after dipping in distilled water, gently wipe the seals and sealing surfaces. If the leaking issue remains after these steps, you'll need to remove the door gasket for thorough cleaning.

If the door gasket is damaged, please replace with a new one. If the autoclave has run for 2000 cycles, it is strongly recommended to replace with a new one.

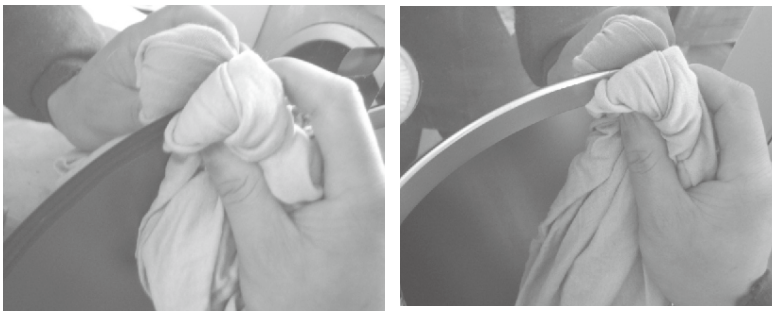

11.6 Replace the door gasket

Tools: Prepare a small slotted screwdriver, pay attention that the head should not have a sharp point. Please take following steps for the replacement:



1> Hold the edge of the seal with one hand and insert the screw driver beneath the seal with your other hand, and then pull out the seal slowly.

2> Once a section of the seal is pulled out, you may pull out the whole seal out slowly, and clean the groove of the seal and check whether the seal is damaged or not, if yes, please do replace with a new one.

3> After cleaning, mount the seal evenly back to into the groove.

Attention:

- 1>The seal must be embedded evenly to the groove.
- 2> When put the seal back into the groove, the inner edge might bend upwards, you may use a screw driver to press the edge tightly to the groove.

11.7 Safety valve inspection and replacement

To prevent the safety valve being blocked, it is recommended to release the safety valve monthly with the steam pressure go through it.

- 1> Run the sterilization program.
- 2>When the sterilizer pressure reaches 100KPa, pull safety valve, and keep it under open status for around 2 minutes, if there is steam discharged, indicating that safety valve is working properly.
- 3>Please contact your dealer or manufacturer for a replacement if you found the safety valve not work properly.

Attention: When you pull the safety valve, the steam will be discharged, so it is recommended to adopt a tool such like a screwdriver, instead of using your fingers directly. Besides, the operator should stay away from the machine as possible to prevent from being hurt.

11.8 Battery Replacement

During the operation, if you find the sterilization records shows 2001 year, that mean the battery is out of use, need to replace a new battery.

- 1>Turn of the power.
- 2>Open the right side panel with a Phillips screw driver.
- 3>Remove the battery from circuit board by using a knife or other tool to.
- 4> Install the same specs battery (battery specifications: CR2032).
- 5> Install the right side panel with a Phillips screwdriver.

11.9 Clean the whole machine

Instructions: Use the burr-free cloth, dip it into the distilled water, gently wipe the sterilizer housing, wipe of dirt from the surface and then wipe the surface to dry.

12. Malfunction analysis

12.1 Most frequently encountered failure:

When there is a failure occur, there is error code displayed in the time display area ,accompanied by "Didi" sound at the same time. Please contact your dealer or manufacturer timely.

When the failure occurs, please following steps to take the items from the chamber.

Turn of the power switch.

Restart the power switch.

Take the items out from the chamber in same method as operation of opening the door

Error Code	Malfunction	Cause	Troubleshooting
E00	Program Exit	Manually exit during the operation	Restart the Program
E10	Pressure Sensor Malfunction	Pressure over detected ≥ 300 KPA	Check the pressure sensor or main board
E11	Internal Temperature Sensor Malfunction	Internal Chamber temp.over detected, $\geq 200^{\circ}\text{C}$	Check the inner temperature sensor and calbes of inner chamber or change the temperature sensor
E12	Sensor Of Steam Generator Malfunction	Steam generator temp.over detected, $\geq 2250^{\circ}\text{C}$	Check the temperature sensor and calbes of steam generator or change the temperature sensor
E13	Outer Temperature Sensor Malfunction	Chamber temp. over detected, $\geq 200^{\circ}\text{C}$	Check the outer temperature sensor and calbes of outer chamber or change the temperature sensor
E14	The Temperature Sensor Malfunction Of Heating Loop1		Check the temperature sensor and calbes of heating loop 1 or change the temperature sensor
E15	Sensor Of Steam Generator 2 Malfunction		Check the temperature sensor and calbes of steam generator 2 or change the temperature sensor
E16	The Temperature Sensor Malfunction Of Heating Loop2		Check the temperature sensor and calbes of heating loop 2 or change the temperature sensor
E41	Constant Temperature And Pressure Failure	Actual temp.exceeds sterilization temp.+4 $^{\circ}\text{C}$	Check temperature sensor,main board and related pipes if it's blocked
E42	Constant Temperature And Pressure Failure	Actual temp.is lower than sterilization temp.	Check the temperature sensor or main board, door sealin lring, solenoid valve and related pipes to see if they are leaking
E02	Pressure Over	Chamber pressure exceeds the preset value(≥ 265 KPA)	Check the pressure sensor, main board, exhaust valve, drain valve and related pipes if they are blocked
E03	Chamber Temp. Over	Chamber temp.exceeds set value($\geq 200^{\circ}\text{C}$)	Check the temperature sensor of the chamber and connecting wires
E05	Steam Exhaust Failure	The pressure discharge rate in the chamber is lower than the preset value(Pressure discharge rate lower than preset value which is 60 seconds <10kPa)	Check whether exhaust valve, drain valve and related pipes are blocked
E06	Door Malfunction	Door loosened	Check whether the door switch, door switch wire and door body are adjusted in right place
E71	Steam Generator1 Over Temperature	Steam generator 1 over temperature and continuous 15S>210	Check the temperature sensor or main board, inlet valve and water tank
E71	Steam Generator1 Over Temperature	Steam generator 2 over temperature and continuous 15S>210	Check the temperature sensor or main board, inlet valve and water tank

Error Code	Malfunction	Cause	Troubleshooting
E08	Heating Time Over	Sterilization preheating time exceeds preset value, the chamber temp. is less than 50°C in 30 minutes, and the steam generator is less than 170°C in 45 minutes.	Check the temperature sensor, main board, temperature protector, connecting wires if they are falling off
E91	The First Time Vacuum Failure	The first vacuum is less than -20KPA within 12 minutes/ in pressure mode, -80KPA is pumped by vacuum in 12 minutes(only for 45L)	1.Check the vacuum pump is running; 2.Check two positions three ways valve, drain valve and exhaust valve if it's blocked. 3.Check water filter in the chamber if it's blocked
E92	The Second Time Vacuum Failure	The second vacuum is less than -20KPA within 8 minutes/ in pressure mode, -70KPA is pumped by vacuum in 8 minutes(only for 45L)	1.Check the vacuum pump is running; 2.Check two positions three ways valve, drain valve and exhaust valve if it's blocked. 3.Check water filter in the chamber if it's blocked
E93	The Third Time Vacuum Failure	The third vacuum is less than -20KPA within 8 minutes/ in pressure mode, -70KPA is pumped by vacuum in 8 minutes(only for 45L)	1.Check the vacuum pump is running; 2.Check two positions three ways valve, drain valve and exhaust valve if it's blocked. 3.Check water filter in the chamber if it's blocked
E94	LEAK Program Vacuum Failure	The vacuum is less than -20KPA within 4 minutes in the leak test(only for 45L)	1.Check the vacuum pump is running; 2.Check two positions three ways valve, drain valve and exhaust valve if it's blocked. 3.Check water filter in the chamber if it's blocked
E95	The First Time Vacuum Failure	For the first pressure boost, the pressure is less than 100KPA in 30 minutes	1.Check the water pump, inlet valve. 2.Check the steam generator is hotting 3.Check the inlet water pipe whether is blocked or the water tank is short of water
E96	The Second Time Vacuum Failure	For the second pressure boost, the pressure is less than 100KPA in 30 minutes	1.Check the water pump, inlet valve. 2.Check the steam generator is hotting 3.Check the inlet water pipe whether is blocked or the water tank is short of water
E97	The Third Time Vacuum Failure	For the third pressure boost, the pressure is less than 100KPA in 30 minutes	1.Check the water pump, inlet valve. 2.Check the steam generator is hotting 3.Check the inlet water pipe whether is blocked or the water tank is short of water
A01	Water Quality Alert	Water quality in water tank is unqualified	Please use distilled water and still check the main board.
A02	Water Refill Alert	Water shortage in water tank	Please add water, still check water level switch and main board
A03	Wasted Water Tank Full Alert	Water full in used water tank	Discharge used water, still check water level switch, main board
EL	Door Motor Malfunction	The limit switch is not encountered within the specified time	1.When open or close the door, check whether the motor is running. 2.Whether the door tone is too tight.

12.2 How to handle with the sterilizing items when the autoclave is suddenly power off

During sterilizing cycle, if the autoclave is suddenly power off, please wait until the pressure inside the chamber is exhausted and the temperature is decreased to normal room temperature, then you can only get out the sterilizing instruments from the chamber. Please pay attention that there may be some water inside the chamber, please do as following way:

1. Turn off the power.
2. Open the right side plate of autoclave by Phillips screwdriver.
3. Use your hand to touch the end of the door-open motor, rotate the hand crew nut at the end of the motor until the door hook and door cover are separated.
4. Take out the instruments from the chamber.
5. Install back the right side plate by Phillips screwdriver.

13. Transportation and storage

The condition of transportation and storage

Environment temperature: $-40^{\circ}\text{C}\sim+55^{\circ}\text{C}$

Relative humidity: $\leq 85\%$ Atmosphere: $50\text{kPa}\sim 106\text{kPa}$.

Warning for transportation and storage:

1>Take of the draining pipe, empty the waste water tank.

2> After chamber cool down, empty all pipes and clean water tank. Dry the clean water tank and chamber.

3>Turn on the power switch, after self- - checking, close the door.

14. Waste disposal

In accordance with Directives 2002/95/ EC, 2002/96/ EC and 2003/108/ EC, regarding the reduction in use of dangerous substances in electrical and electronic equipment, as well as waste disposal, such equipment may not be disposed of as normal urban waste and must be separated accordingly. When purchasing a new, equivalent piece of equipment, the old piece of equipment.

that has reached its end-of-life must be handed over to the reseller for proper disposal. As regards reuse, recycling and other forms of recovery of the above mentioned waste, the manufacturer carries out the functions defined in the individual national legislations. The proper collection and separation of such equipment for recycling, treatment and disposal helps avoid any possible negative effects on the environment and health and facilitates the recycling of the materials of which the equipment is made. The crossed out rubbish can symbol indicates that the product, at the end-of-life, must be collected separately from other types of waste.

Appendix 1 Schematic diagram

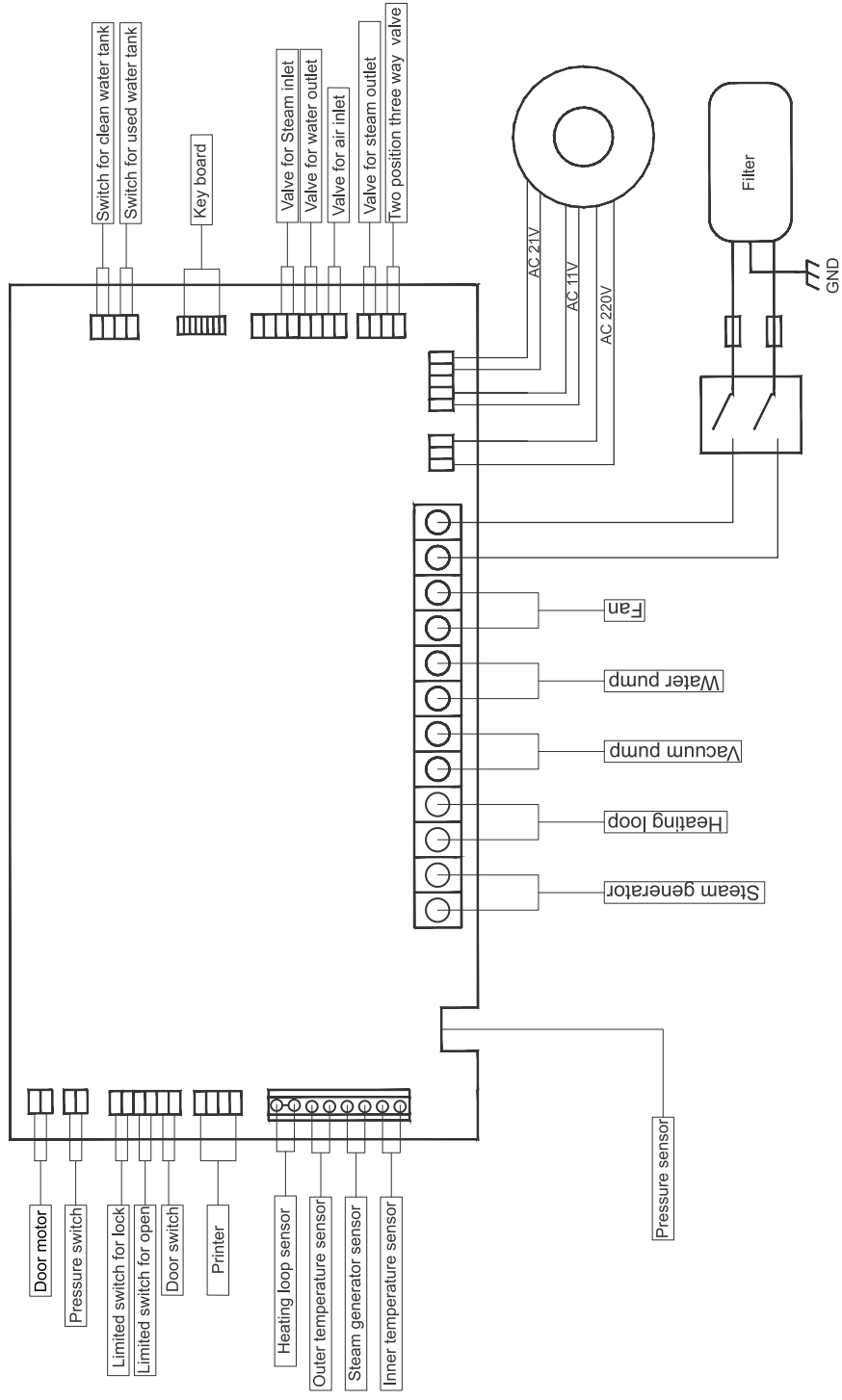

Appendix 2 Pipeline diagram □ Vacuum pump

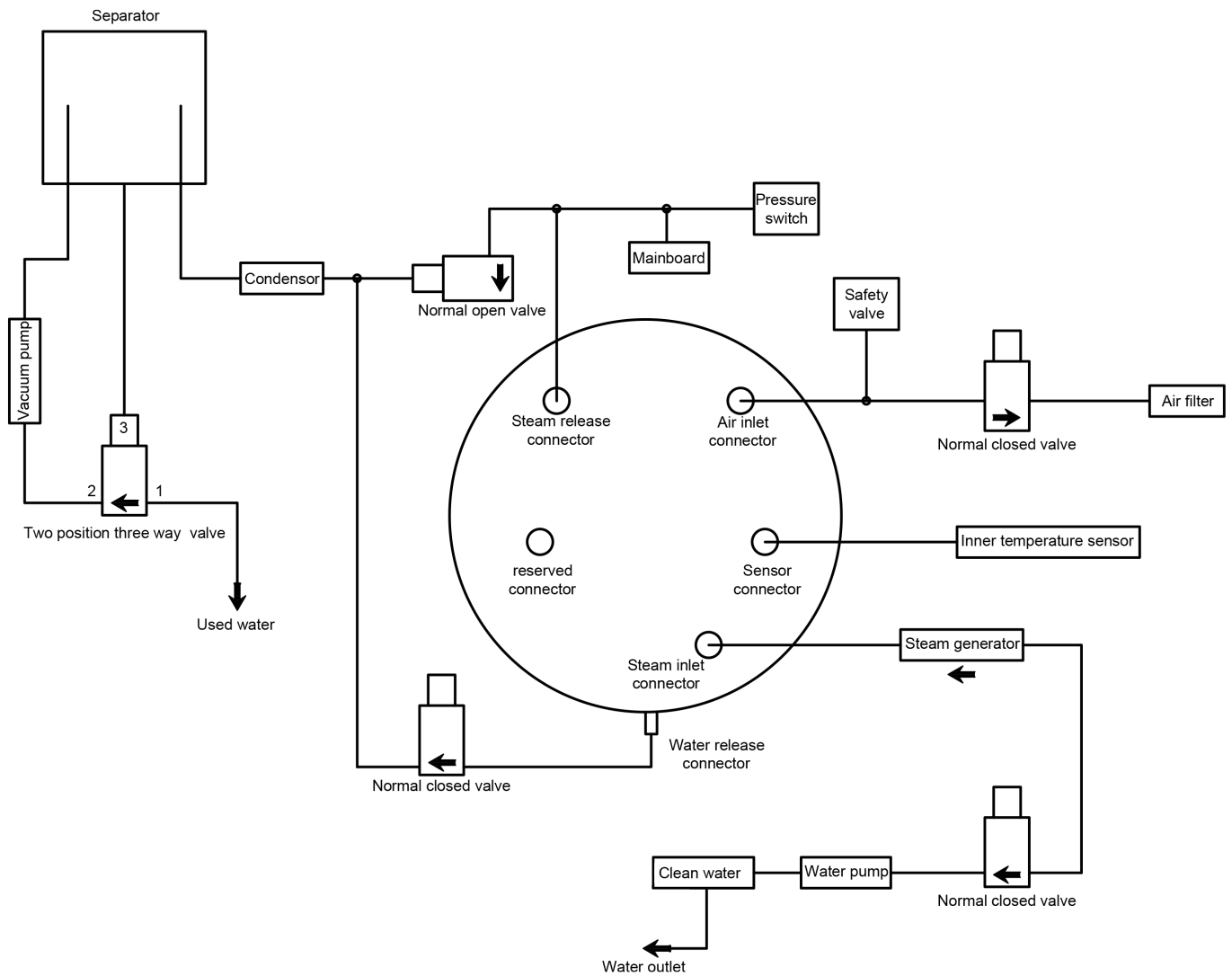

Appendix 2 Pipeline diagram □ Water circulation pump

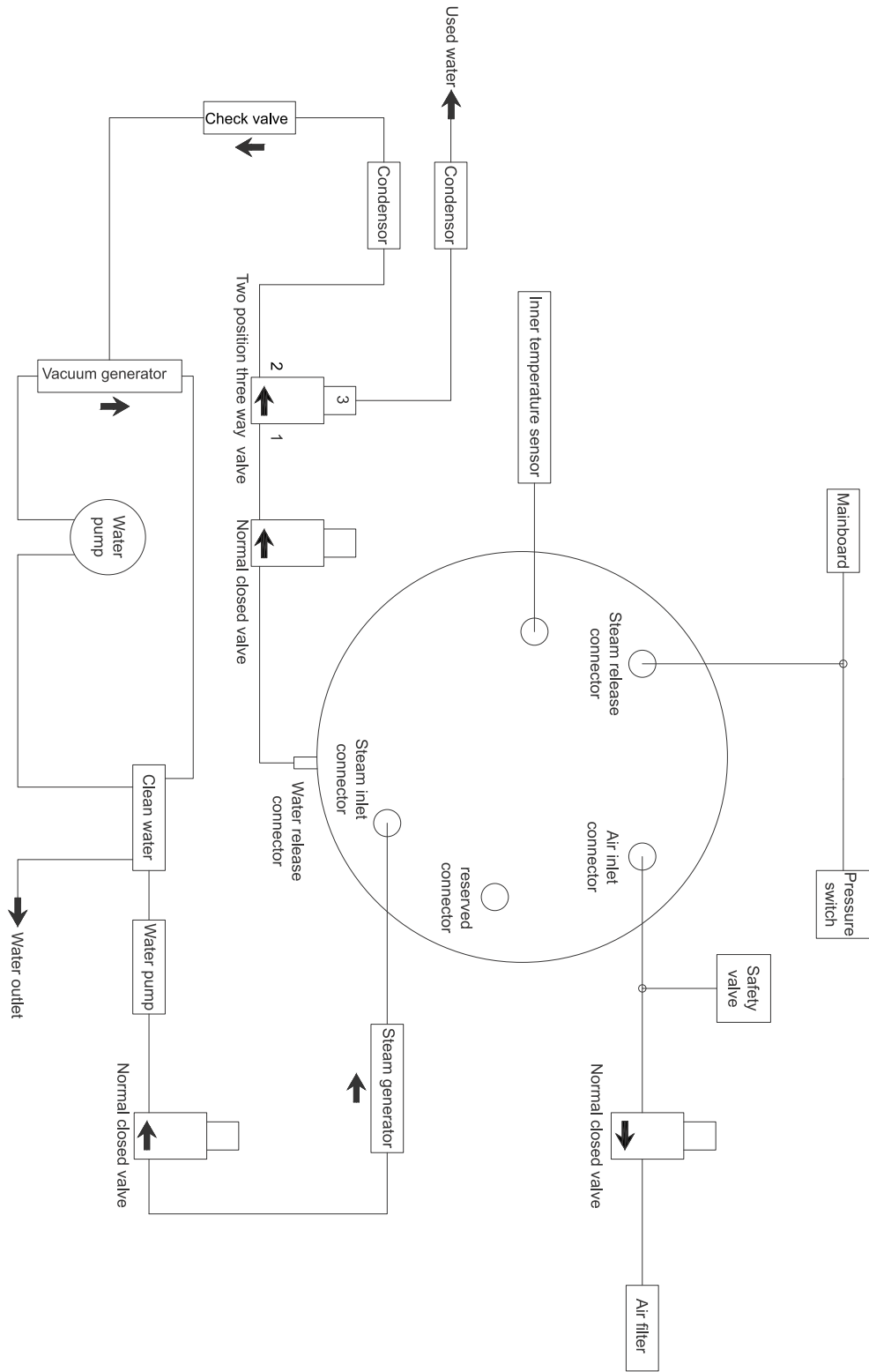

Appendix 3 Pressure steam sterilizer operation instructions

1. Preparation before use

- 1>Add the distilled water to the clean water tank as requested
- 2>Connect through the electricity power, to let the sterilizer be in power on state, being ready for running programs
- 3>Running B&D testing program, to test if the equipment is in good condition
- 4>Finishing the sterilizing package, not banding too tight, put on the chemical indicator tape outside, put chemical indicator card inside

2. Sterilizing operation

- 1>After passing B&D testing program, put the sterilizing instruments into the chamber, ensure the empty space among the packages, don't touch the chamber side and door seal cover.
- 2>Close the door of sterilizer, select the sterilizing program according to the sterilizing instruments, check if the sterilizing parameter is correct, start the sterilizing program.
- 3>During the sterilizing cycle, the operator can not be far away from the equipment, and should observe the running situation of the equipment, take measures in time to deal with if any abnormal situation to avoid any accidents.
- 4>Monitor sterilization effect, and make records for tracking in future.
- 5>After sterilization cycle inished, please wait until the pressure inside the chamber is exhausted, then you can only open the door and get out the sterilizing instruments from the chamber.
- 6>After the sterilizing instruments are taken out from the sterilizer, should check and put in proper place carefully to avoid secondary pollution.

3. Preparation after use

- 1>Open the door, let the power switch be in disconnecting state, cut off the power supply of the equipment.
- 2>Please replace the water if the equipment reminds you for bad water quality. After daily work, keep the sterilizer clean both inside and outside, please clean the dirt in the chamber by using a clean cloth and water, weekly little maintenance, and monthly big maintenance.

4. Precautions:

- 1>Don't mix the sterilized items with non-sterilized items together;
- 2>Please indicate sterilization date and pass mark on qualified sterilized items, Company name of user Year Month Date.

Appendix IV. Emergency Opening Method for Door Failure

This sterilizer is controlled by an electric mechanism to open or lock the door. When you encounter power failure or failure of the electric mechanism during the sterilization cycle, you will not be able to open the door as normal. However, if you are in urgent to take out instruments in the sterilizer before the failure is restored, you can do the following operation 10 minutes after the failure:

1. Find the emergency door opener on the back of the sterilizer as following picture:

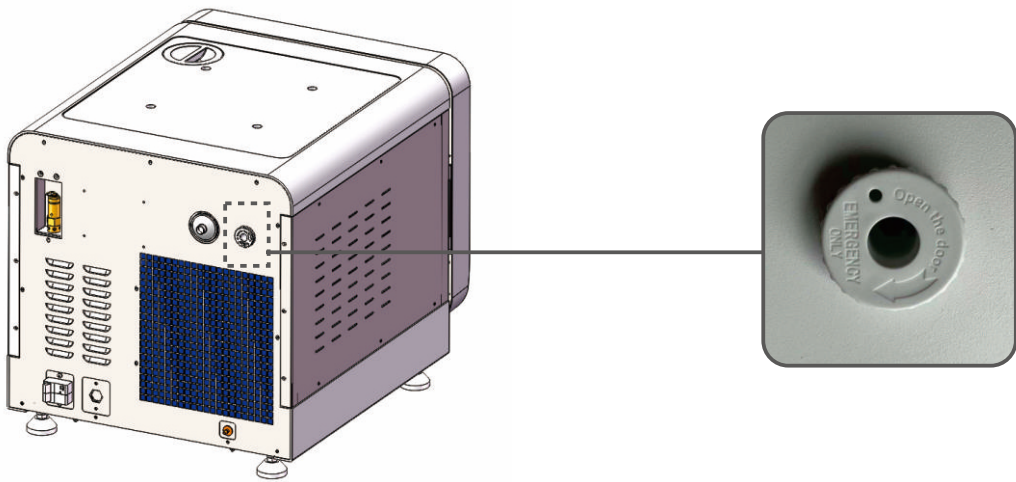

2. Insert the emergency door opener tightly into the round hole at the bottom of the right front of the sterilizer as follows:

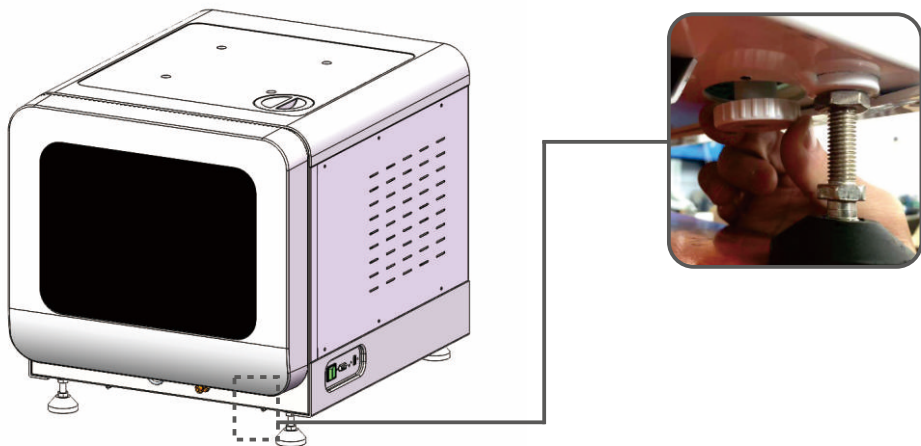

3. Rotate to the direction marked on the opener and try to open the door after turning about a certain number of circles (about 45 circles). When the door of the sterilizer can be opened, stop rotating the opener to avoid excessive rotation damage to the mechanism components.



Ningbo Runyes Medical Instrument Co., Ltd.

Add: 032 Building, No. 456, Tonghui Road, Jiangbei Investment
& Pioneering Park C, 315033, Ningbo, China

Tel : +86-574-27709922

Fax: +86-574-27709923

Email: runyes@runyes.com

<http://www.runyes.com>



Shanghai International Holding Corp.GmbH (Europe)

Eiffestrasse 80,20537 Hamburg,Germany

Tel : +49-40-2513175

Fax : +49-40-255726

Version Number:2020-09-28