



# FMB125

Advanced 2G tracker with RS232, RS485 interfaces



## EXTENDED PRODUCT USAGE SCENARIOS

Bluetooth® LE-based wireless connection of external devices, including Low Energy beacons and sensors to monitor temperature, humidity, magnet detection, and movement

## FUEL MONITORING AND MORE

RS232/RS485 serial interfaces for fuel monitoring and other external data reading

## SIGNIFICANTLY LOWER ROAMING COSTS

Dual SIM considerably reduces roaming costs

## ACCURATE FUEL USAGE CONTROL

Impulse input for fuel flow meters data reading and accurate fuel usage control



Light vehicles



Trailer Tracking



Refrigerated transport



International logistics



Car Sharing

Teltonika FMB125 is SPECIAL tracker with external GNSS, internal GSM antennas, Bluetooth® connectivity and backup battery. FMB125 is designed for communication with various third party RS232 or RS485 devices, like digital fuel sensors (LLS), Garmin navigation device, RFID reader and much more. It is also excellent for refrigerated transport, because it has extended input/output set and 1-wire interface for temperature monitoring. With Teltonika CAN adapters, FMB125 can be even used in agriculture or construction & mining.

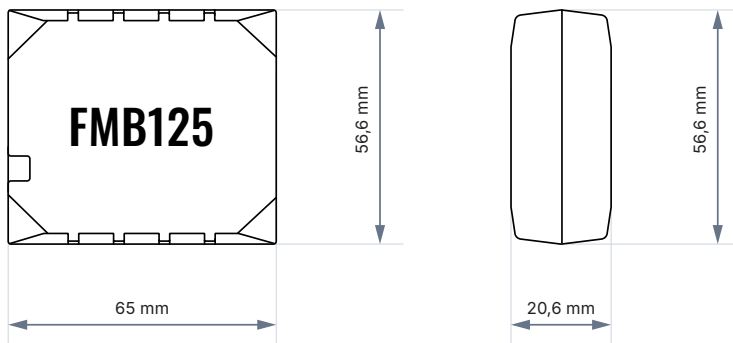

### Module

Name	Teltonika TM2500
Technology	GSM/GPRS/GNSS/BLUETOOTH® LE

### GNSS

GNSS	GPS, GLONASS, GALILEO, BEIDOU, SBAS, QZSS, DGPS, AGPS
Receiver	33 channel
Tracking sensitivity	-165 dBm
Position accuracy	< 2.5 CEP
Velocity accuracy	< 0.1m/s (within +/- 15% error)
Hot start	< 1 s
Warm start	< 25 s
Cold start	< 35 s

### Cellular

Technology	GSM
2G bands	Quad-band 850 / 900 / 1800 / 1900 MHz
Data transfer	GPRS Multi-Slot Class 12 (up to 240 kbps), GPRS Mobile Station Class B
Data support	SMS (text/data)

### Power

Input voltage range	10 - 30 V DC with overvoltage protection
Internal Back-up battery	170 mAh Li-Ion battery 3.7 V (0.63 Wh)

### Power Consumption

At 12V < 6mA	Ultra Deep Sleep
At 12V < 6.5mA	Deep Sleep
At 12V < 7mA	Online Deep Sleep
At 12V < 12mA	GPS Sleep
At 12V < 38 mA	Nominal with no load

**BLUETOOTH® technology**

Specification	4.0 + LE
Supported peripherals	Temperature and Humidity sensor, Headset, OBDII dongle, Inateck Barcode Scanner, Universal Bluetooth® LE sensors support

**Physical specification**

Dimensions	65 × 56.6 × 20.6 mm (L x W x H)
Weight	52 g

**Operating environment**

Operating temperature (without battery)	-40 °C to +85 °C
Storage temperature (without battery)	-40 °C to +85 °C
Operating humidity	5% to 95% non-condensing
Ingress Protection Rating	IP41
Battery charge temperature	0 °C to +45 °C
Battery discharge temperature	-20 °C to +60 °C
Battery storage temperature	-20 °C to +45 °C for 1 month -20 °C to +35 °C for 6 months

**Interface**

Digital Inputs	1
Digital Outputs	1
Analog Inputs	1
CAN Adapter Inputs	1
1-Wire	1
RS232	1
RS485	1
GNSS antenna	External (SMA connector) / internal (optional)
Cellular antenna	Internal GSM High Gain
USB	2.0 Micro-USB
LED indication	2 status LED lights
SIM	Dual SIM
Memory	128MB internal flash memory

## Features

Sensors	Accelerometer
Scenarios	Green Driving, Over Speeding detection, Jamming detection, GNSS Fuel Counter, DOUT Control Via Call, Excessive Idling detection, Immobilizer, iButton Read Notification, Unplug detection, Towing detection, Crash detection, Auto Geofence, Manual Geofence, Trip
Sleep modes	GPS Sleep, Online Deep Sleep, Deep Sleep, Ultra Deep Sleep
Configuration and firmware update	FOTA Web, FOTA, Teltonika Configurator (USB, Bluetooth® wireless technology), FMBT mobile application (Configuration)
SMS	Configuration, Events, DOUT control, Debug
GPRS commands	Configuration, DOUT control, Debug
Time Synchronization	GNSS, NITZ, NTP
Fuel monitoring	LLS (Analog), RS232/485 Fuel sensor, LV-CAN200, ALL-CAN300, CAN-CONTROL, OBDII dongle
Ignition detection	Digital Input 1, Accelerometer, External Power Voltage, Engine RPM (CAN Adapters, OBDII dongle)
RS232 Modes	Log Mode, NMEA, LLS, LCD, RFIH HID/MF7, Garmin FMI, TCP ASCII/Binary
RS485 Modes	Log Mode, NMEA, LLS, TCP ASCII/Binary
RS485 input voltage range on A or B pin (common-mode voltage)	-7V to +12V
RS232 input voltage range (common-mode voltage)	+/-15V
RS232 input voltage range (maximum operational voltage)	+/-25V

## Certification & Approvals

Regulatory	CE/RED, E-Mark, EAC, RoHS, REACH, Anatel (internal)
------------	---