

Three-phase electricity meter smartESOX P

Application

Multi-tariff, four-quadrant electricity meter in three-phase, 3- or 4-wire network for HV-, MV- or LV-powered consumers of all tariff groups. Extended measuring and registering functionalities are complemented by multiple communication options. It is an optimal solution for advanced power management systems (EMS). Typical use: commercial/industrial meter; balancing meter.



Functionality

- Measurement of active, reactive and apparent energy
- Measurement of instantaneous, maximum, redundant and cumulative power
- Measurement of transformer losses: OLA, NLA, OLR, NLR, I^2t , U^2t
- Measurement of network parameters, including: voltages, currents, voltage and current harmonics, frequencies, THD, asymmetry factor and neutral wire current
- Monitoring of power grid parameters: voltage sags and swells; long power outages; current and voltage asymmetry; current flow with no applied voltage; no current flow; exceeded current limit
- Direct, semi-direct and indirect connection through current transformers, optionally also through voltage transformers
- Recording of energy in 6 tariff zones, switched by an internal real time clock
- Wide range of recording capabilities for measured parameters:
 - independently configurable profiles with different recording intervals
 - ability to configure a different set of recorded data for each profile
- Enhanced event logging
 - 7 groups of events, recorded in independent logs
 - Sending immediate event notifications to the host device/system
- Wide range of recording capabilities for measured parameters in reference periods
 - Up to 50 parameters recorded in reference periods
- DLMS/COSEM communication protocol, possibility to read measurement data through the EN 62056-21 (IEC1107) protocol
- 3 built-in communication ports: one optical, two serial
- Interchangeable communication module: GPRS, 3G, 4G
- Built-in emergency power supply connected to an external power source
- Ability to read energy registers on the display in case of power outage - powered by a AA size battery

Basic technical parameters

Model	smartESOX P	
Connection method	CT or CT/VT connected	
Rated voltage U_n	[V]	3 x 58/100...3x230/400
Reference current I_{ref}	[A]	1 or 5
Maximum current I_{max}	[A]	6
Accuracy class for active energy	B or C	
Accuracy class for reactive energy	3 or 2	
Insulation	[kV]	4 (AC 50 Hz), 6 or 8 - optional (surges 1,2/50 μ s)
Meter constant	[imp/kWh] [imp/kvarh]	20 000
RTC	Internal, accuracy not lower than 0.5 s/24 h at 23 °C, synchronised by external signal or by communication port.	
Communication	DLMS/COSEM protocol support (EN 62056-5-3, EN 62056-6-2) optional data reading through serial ports with IEC protocol (EN 62056-21) (IEC1107) Ports: <ul style="list-style-type: none"> • Optical port (EN 62056-21), up to 19200 Bd. • 2 independent serial ports (2x RS485 or 1x RS-485 and 1xRS-232), 300 Bd to 57,600 Bd. • Interchangeable communication module - GPRS, 3G, 4G 	
Inputs	2 optically isolated inputs (features: control of registration, tariffs, synchronised RTC, alarm input, pulse counter).	
Outputs	Up to 6 pulse outputs (for energy counting). 2 programmable relay outputs.	
Event logging	Sags and swells of phase voltages, long power outages, opening and closing of the terminal cover and meter case, magnetic field influences, exceedance of I_{max} , P_{max} , non-voltage current, configuration, deleting events, critical error, change of RTC settings, events on digital inputs. Events are registered with their date and time.	
Display	Segment display compliant with VDEW requirements	
Operating temperature	from -40 °C to 70 °C	
Housing	II protection class	
Ingress protection rating	IP 54	
Standards	EN 50470-1 EN 50470-3 EN 62053-23 EN 62053-11	

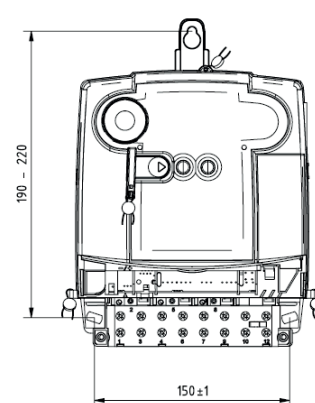
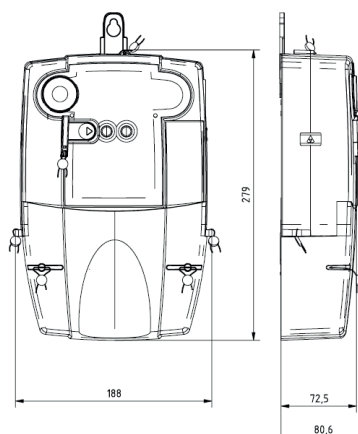

kWh

kvarh

φ

$P_{(t)}$

P_{max}

P_{ill}

$\frac{U}{f}$

I^2h
 U^2h