

## Servo-i Ventilator Spare Parts List

### Figure 3: Patient unit, Inspiratory section

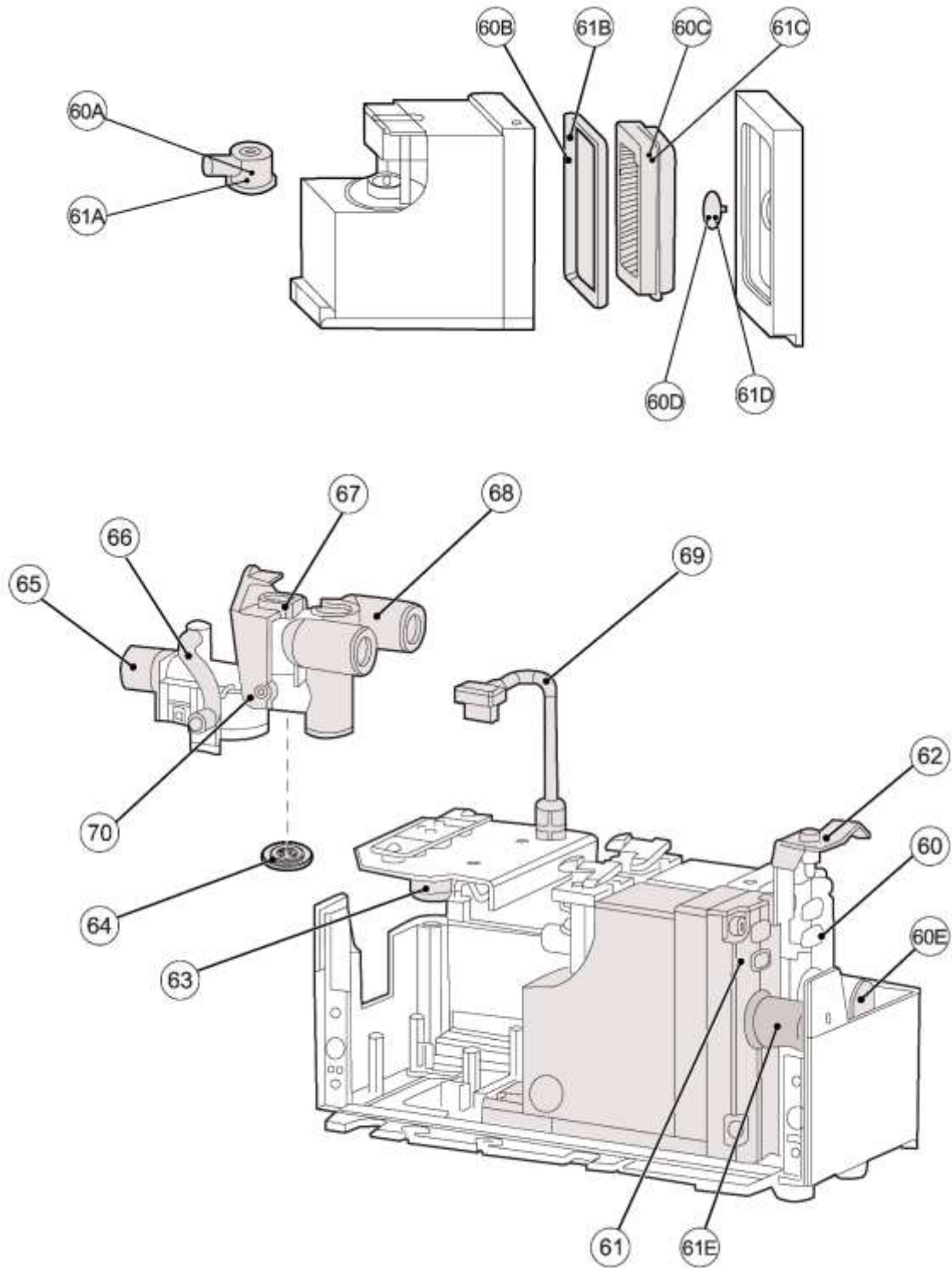

## Servo-i Ventilator Spare Parts List

**Table 3: Patient unit, Inspiratory section**

| ID  | Part no. | Description                      | Comments  |
|-----|----------|----------------------------------|---|
| 60  | 6671137  | Gas module O2, Type III          |   |
| 60A | 6693792  | Nozzle unit                      |   |
| 60B | 6039528  | Rubber seal for bacteria filter  |   |
| 60C | 6169416  | Bacteria Filter for Gas Module   |   |
| 60D | 6169358  | Non-return valve, 2 pcs          |   |
| 60E | 6532654  | Module adapter O2, with O-rings  | Fits only modules with 2 screws in end plate    |
| 61  | 6671135  | Gas module Air, Type III         |   |
| 61A | 6693792  | Nozzle unit                      |   |
| 61B | 6039528  | Rubber seal for bacteria filter  |   |
| 61C | 6169416  | Bacteria Filter for Gas Module   |   |
| 61D | 6169358  | Non-return valve, 2 pcs          |   |
| 61E | 6532647  | Module adapter AIR, with O-rings | Fits only modules wit 2 screws in the end plate |
| 62  | 6488113  | Module bracket                   |   |
| 63  | 6670330  | Pull magnet incl. bracket        |   |
| 64  | 9303892  | Filter for O2 cell, 25 pcs       |   |
| 65  | 6532662  | Inspiratory pipe                 |   |
| 66  | 6532977  | Tube                             |   |
| 67  | 6640044  | O2 cell                          |   |
| 68  | 6448612  | Connector muff                   |   |
| 69  | 6487958  | Cable for O2 cell                |   |
| 70  | 6888750  | O2 cell holder                   |   |



# Certificate

No. Q5 072017 0013 Rev. 01

**Holder of Certificate:** **MAQUET CRITICAL CARE AB**  
GETINGE ✱  
Röntgenvägen 2  
171 54 Solna  
SWEDEN

**Facility(ies):** MAQUET CRITICAL CARE AB  
Röntgenvägen 2, 171 54 Solna, SWEDEN

See Scope of Certificate

**Certification Mark:**



**Scope of Certificate:** **Design, development and manufacturing of Anaesthesia, Monitoring, Ventilator Systems and Perfusion Systems**

**Applied Standard(s):** EN ISO 13485:2016  
Medical devices - Quality management systems - Requirements for regulatory purposes (ISO 13485:2016)  
DIN EN ISO 13485:2016

The Certification Body of TÜV SÜD Product Service GmbH certifies that the company mentioned above has established and is maintaining a quality management system, which meets the requirements of the listed standard(s). All applicable requirements of the testing and certification regulation of TÜV SÜD Group have to be complied with. For details and certificate validity see: [www.tuvsud.com/ps-cert?q=cert:Q5\\_072017\\_0013\\_Rev.\\_01](http://www.tuvsud.com/ps-cert?q=cert:Q5_072017_0013_Rev._01)

**Report No.:** 713193727

**Valid from:** 2020-12-30

**Valid until:** 2023-12-29

**Date,** 2020-12-28

Christoph Dicks  
Head of Certification/Notified Body





Benannt durch/Designated by  
Zentralstelle der Länder  
für Gesundheitsschutz  
bei Arzneimitteln und  
Medizinprodukten  
www.zlg.de  
BS-MDR-099



Product Service

## EU Quality Management System Certificate (MDR)

Pursuant to Regulation (EU) 2017/745 on Medical Devices, Annex IX Chapters I and III  
(Class IIa and Class IIb Devices)

**No. G10 072017 0015 Rev. 00**

| Device(s):   | Risk classification | CND Code | Intended Purpose  |
|--|---------------------|----------|---|
| INSTRUMENTS FOR ANESTHESIA AND PULMONARY VENTILATION SUPPORT | IIb                 | Z120301  | Intended for respiratory support, administration of anesthetic and treatment of neonatal, pediatric and adult patients. |

The validity of this certificate depends on conditions and/or is limited to the following: ./.

Revision History including Changes:

Revision / Issue Date / Report  
Rev. 00 / 2020-02-17 / 713170827