

INTERNATIONAL
STANDARD

ISO
8537

Third edition
2016-03-15

**Sterile single-use syringes, with or
without needle, for insulin**

Seringues à insuline, stériles, non réutilisables, avec ou sans aiguille



Reference number
ISO 8537:2016(E)

© ISO 2016



COPYRIGHT PROTECTED DOCUMENT

© ISO 2016, Published in Switzerland

All rights reserved. Unless otherwise specified, no part of this publication may be reproduced or utilized otherwise in any form or by any means, electronic or mechanical, including photocopying, or posting on the internet or an intranet, without prior written permission. Permission can be requested from either ISO at the address below or ISO's member body in the country of the requester.

ISO copyright office
Ch. de Blandonnet 8 • CP 401
CH-1214 Vernier, Geneva, Switzerland
Tel. +41 22 749 01 11
Fax +41 22 749 09 47
copyright@iso.org
www.iso.org

Contents

Page

Foreword	v
Introduction	vi
1 Scope	1
2 Normative references	1
3 Terms and definitions	2
4 Types of syringes	5
5 Requirements	5
5.1 General requirements.....	5
5.2 Material selection.....	6
5.3 Colour coding.....	6
5.4 Extraneous matter.....	7
5.4.1 General.....	7
5.4.2 Limits for acidity or alkalinity.....	7
5.4.3 Limits for extractable metals.....	7
5.5 Lubrication.....	7
5.5.1 Lubrication of syringes.....	7
5.5.2 Lubrication of needle tube.....	8
5.6 Dimensions.....	8
5.6.1 Barrel and plunger stopper.....	8
5.6.2 Finger grips.....	8
5.7 Plunger/plunger stopper.....	8
5.7.1 General.....	8
5.7.2 Fit of plunger stopper in barrel.....	8
5.8 Nozzle.....	8
5.8.1 Conical fitting.....	8
5.8.2 Position of nozzle on end of barrel.....	8
5.9 Needle tubing and needles.....	9
5.9.1 Needles for syringe types 3 and 4.....	9
5.9.2 Needle tubing for syringe types 5, 6, 7 and 8.....	9
5.9.3 Bond between hub and needle tube.....	9
5.10 Standard test environmental conditions.....	9
5.11 Performance of assembled syringe.....	9
5.11.1 Dead space.....	9
5.11.2 Freedom from leakage at needle.....	10
5.11.3 Freedom from leakage past plunger stopper.....	10
6 Packaging	10
6.1 Unit packaging and self-contained syringe units.....	10
6.1.1 General.....	10
6.1.2 Unit packaging providing sterile barrier syringes (types 1, 3, 5 and 7).....	10
6.1.3 Self-contained syringes with sterile interiors (types 2, 4, 6 and 8).....	10
6.2 Multiple-unit packaging (for syringe types 2, 4, 6 and 8).....	11
6.3 User packaging.....	11
7 Information supplied by the manufacturer	11
7.1 General.....	11
7.2 Syringes.....	11
7.2.1 General.....	11
7.2.2 Additional marking for self-contained syringes (syringe types 2, 4, 6 and 8).....	12
7.3 Unit packaging (for syringe types 1, 3, 5 and 7).....	12
7.4 Multiple unit packs (syringe types 2, 4, 6 and 8).....	12
7.5 User packaging.....	13
7.6 Storage container.....	14
7.7 Transport wrapping.....	14

Annex A (normative) Fluid for determination of acidity/alkalinity and extractable metals	15
Annex B (normative) Test method for air leakage past syringe piston during aspiration and for separation of rubber stopper and plunger	16
Annex C (normative) Test method for determination of forces required to operate piston	18
Annex D (normative) Test method for determination of dead space	20
Annex E (normative) Test method for liquid leakage at syringe piston and syringe nozzle/hub or needle/barrel unions during compression	21
Annex F (normative) Test method for air leakage past nozzle/hub or needle/barrel unions during aspiration	23
Annex G (normative) Preparation of extract for test for pyrogenicity and toxicity	24
Annex H (normative) Syringe sizes and graduated scales	25
Bibliography	27

Foreword

ISO (the International Organization for Standardization) is a worldwide federation of national standards bodies (ISO member bodies). The work of preparing International Standards is normally carried out through ISO technical committees. Each member body interested in a subject for which a technical committee has been established has the right to be represented on that committee. International organizations, governmental and non-governmental, in liaison with ISO, also take part in the work. ISO collaborates closely with the International Electrotechnical Commission (IEC) on all matters of electrotechnical standardization.

The procedures used to develop this document and those intended for its further maintenance are described in the ISO/IEC Directives, Part 1. In particular the different approval criteria needed for the different types of ISO documents should be noted. This document was drafted in accordance with the editorial rules of the ISO/IEC Directives, Part 2 (see www.iso.org/directives).

Attention is drawn to the possibility that some of the elements of this document may be the subject of patent rights. ISO shall not be held responsible for identifying any or all such patent rights. Details of any patent rights identified during the development of the document will be in the Introduction and/or on the ISO list of patent declarations received (see www.iso.org/patents).

Any trade name used in this document is information given for the convenience of users and does not constitute an endorsement.

For an explanation on the meaning of ISO specific terms and expressions related to conformity assessment, as well as information about ISO's adherence to the WTO principles in the Technical Barriers to Trade (TBT) see the following URL: [Foreword - Supplementary information](#).

The committee responsible for this document is ISO/TC 84, *Devices for administration of medicinal products and catheters*.

This third edition cancels and replaces the second edition (ISO 8537:2007), which has been technically revised to include the following changes:

- a) revised the introduction;
- b) revised the scope to include various concentrations of insulin, specified plastic materials and excluded, e.g. single-use syringes made of glass;
- c) added some normative references;
- d) added new definitions;
- e) added new colour codes for higher concentration of insulin;
- f) clarified the drawing to illustrate the component of the syringe;
- g) included general requirements;
- h) revised test methods for syringes;
- i) revised the labelling requirement;
- j) moved the syringe sizes and graduated scales in [Annex H](#);
- k) deleted Annex I.

Introduction

This International Standard covers insulin syringes primarily intended for human use and provides performance and testing requirements. It permits broader variation in design so as to not limit innovation in technology or methods of packaging. Its appearance and layout are consistent with other TC 84 International Standards, which are designed to be more performance-based than design-prescriptive.

Manufacturers are expected to follow a risk-based approach and employ usability engineering during the design, development and manufacture of insulin syringes.

This edition introduces general requirements as design guidelines for manufacturers. This edition retains a number of limits on requirements, which were originally based on consensus opinion but subsequently have been confirmed in practice.

This International Standard does not specify materials to be used for the construction and lubrication of sterile insulin syringes and needles for single use because their selection will depend, to some extent, upon the manufacturer's specific syringe design, process of manufacture, and sterilization method.

Insulin syringes and needles are to be manufactured and sterilized in accordance with recognized national or international codes of good manufacturing practice for medical devices.

This International Standard emphasizes the importance of having individual syringes that are appropriately graduated and labelled for only one concentration of insulin. Serious problems can result if a syringe is used with a concentration of insulin that is different from the one for which it was designed. Hazards associated with dosing errors with highly concentrated insulin (U300 and U500) are considered higher than the experience with U40 and U100.

It is preferred that when more than one insulin concentration is in a market, the new concentration be provided in a dedicated delivery system that make miss-dosing less likely.

In acknowledgement that insulin in higher concentrations in vials are available in some markets, new formulations are under development and dedicated delivery systems other than syringes are not always appropriate for all markets, this International Standard introduces new colour codes to differentiate syringes for the new higher concentrations of insulin.

The sampling plans for inspection selected for this International Standard are intended to verify the design at a high confidence level. The sampling plans for inspection do not replace the more general manufacturing quality systems that appear in standards on quality systems, for example, the ISO 9000 series and ISO 13485.

Guidance on transition periods for implementing the requirements of this International Standard is given in ISO/TR 19244, developed by ISO/TC 84.

Sterile single-use syringes, with or without needle, for insulin

1 Scope

This International Standard specifies requirements and test methods for empty, sterile, single-use syringes, with or without needles, made of plastic materials and intended solely for the injection of insulin, with which the syringes are filled by the end user. This International Standard covers syringes intended for single-use only in humans and with insulins of various concentrations.

The insulin syringes specified in this International Standard are intended for use (i.e. insulin injection) immediately after filling and are not intended to contain insulin for extended periods of time.

This International Standard excludes single-use syringes made of glass, syringes for use with power-driven syringe pumps, syringes that are pre-filled by the manufacturer, and syringes intended to be stored after filling (e.g. in a kit intended for filling by a pharmacist).

2 Normative references

The following documents, in whole or in part, are normatively referenced in this document and are indispensable for its application. For dated references, only the edition cited applies. For undated references, the latest edition of the referenced document (including any amendments) applies.

ISO 594-1¹⁾, *Conical fittings with a 6 % (Luer) taper for syringes, needles and certain other medical equipment — Part 1: General requirements*

ISO 3696, *Water for analytical laboratory use — Specification and test methods*

ISO 7864, *Sterile hypodermic needles for single use*

ISO 9626, *Stainless steel needle tubing for the manufacture of medical devices*

ISO 10993-1, *Biological evaluation of medical devices — Part 1: Evaluation and testing within a risk management process*

ISO 11608-1, *Needle-based injection systems for medical use — Requirements and test methods — Part 1: Needle-based injection systems*

ISO 11608-5, *Needle-based injection systems for medical use — Requirements and test methods — Part 5: Automated functions*

ISO 14971, *Medical devices — Application of risk management to medical devices*

ISO 15223-1:2012, *Medical devices — Symbols to be used with medical device labels, labelling and information to be supplied — Part 1: General requirements*

ISO 23908, *Sharps injury protection — Requirements and test methods — Sharps protection features for single-use hypodermic needles, introducers for catheter and needles used for blood sampling*

ISO/IEC 80369-7, *Small bore connectors for liquids and gases in healthcare applications — Part 7: Connectors with 6 % (Luer) taper for intravascular or hypodermic applications (under development)*

IEC 62366-1, *Medical devices — Part 1: Application of usability engineering to medical devices*

1) To be replaced by ISO 80369-7.

3 Terms and definitions

For the purposes of this document, the following terms and definitions apply.

NOTE The nomenclature used for some components of syringes intended for single use is shown in [Figure 2](#).

**3.1
needle cap**
cover intended to protect physically the needle tube prior to use and, for syringes with a fixed needle tube (type 8), to maintain the sterility of the needle

**3.2
plunger stopper**
component connected to the leading end of the plunger and seals the open end of the syringe barrel

**3.3
plunger cap**
cover intended to maintain the sterility of the syringe and to enclose the projecting portion of the plunger and push button, if present

**3.4
fiducial line**
leading edge of the *plunger stopper* ([3.2](#)), which is in contact with and perpendicular to the syringe barrel and aligns with the zero marking on the syringe barrel when the piston is fully inserted

**3.5
graduated capacity**
volume of water, at a temperature of 18 °C to 28 °C, expelled from the syringe when the *fiducial line* ([3.4](#)) on the piston traverses a given scale interval or intervals

**3.6
total graduated capacity**
capacity of the syringe at the graduation line farthest from the zero graduation line

Note 1 to entry: The total graduated capacity may be equal to, or greater than, the nominal capacity.

**3.7
piston**
assembled component of plunger and *plunger stopper* ([3.2](#))

**3.8
unit packaging**
packaging of an individual device, intended to maintain its sterility

**3.9
self-contained syringe**
syringe with protective end caps intended to maintain the sterility of the interior of the syringe

Note 1 to entry: Protective end caps may be *plunger cap* ([3.3](#)), nozzle cap or *needle cap* ([3.1](#)).

**3.10
user packaging**
packaging, which contains one or more items of unit packaging, designed to provide labelling information to the user

**3.11
needle length**
usable length of needle

Note 1 to entry: Needle length is shown in [Figure 1](#).

3.12**nozzle cap**

sheath intended to protect physically the needle hub prior to use

3.13**plunger delivery**

device mechanism which advances the *plunger stopper* (3.2) to deliver the medicinal product

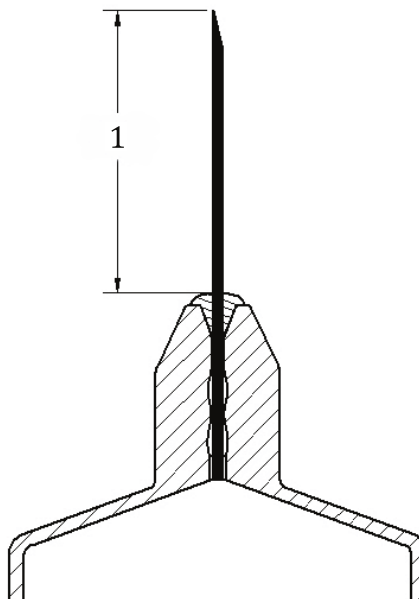
**Key**

1 needle length

Figure 1 — Needle length

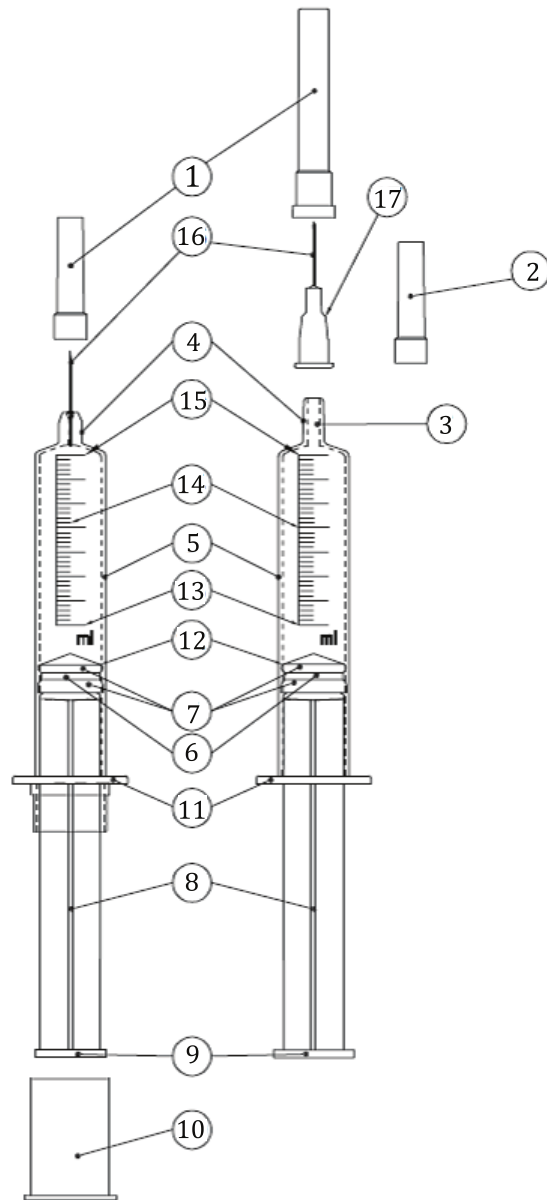

Key

- | | | | |
|---|-----------------|----|------------------|
| 1 | needle cap | 10 | plunger cap |
| 2 | nozzle cap | 11 | finger grips |
| 3 | nozzle lumen | 12 | fiducial line |
| 4 | nozzle | 13 | nominal capacity |
| 5 | barrel | 14 | graduation lines |
| 6 | plunger stopper | 15 | zero line |
| 7 | seals | 16 | needle tube |
| 8 | plunger | 17 | hub |
| 9 | push-button | | |

Note This figure is only intended to be illustrative of the components of a syringe. The piston might or might not be of integral construction and might incorporate more than one seal.

Figure 2 — Schematic representation of insulin syringe for single use

4 Types of syringes

The type of syringe shall be designated as follows.

- **Type 1;** syringe having a 6 % (Luer) male conical fitting, supplied with no needle and packaged in unit packaging.
- **Type 2;** syringe having a 6 % (Luer) male conical fitting, supplied with no needle and fitted with protective end caps and packaged.
- **Type 3;** syringe having a 6 % (Luer) male conical fitting, and supplied with a detached or detachable needle and packaged in a unit packaging.
- **Type 4;** syringe having a 6 % (Luer) male conical fitting and supplied with a detachable needle and fitted with protective end caps and packaged.
- **Type 5;** syringe having a fitting other than a 6 % (Luer) taper, supplied with a needle not intended to be detached and packaged in a unit packaging.
- **Type 6;** syringe having a fitting other than a 6 % (Luer) taper, supplied with a needle not intended to be detached and fitted with protective caps and packaged.
- **Type 7;** syringe with fixed needle tube and packaged in a unit packaging.
- **Type 8;** syringe with fixed needle tube and fitted with protective end caps and packaged.

NOTE This International Standard provides designations for eight types of syringes to encompass different product configurations, but the number of types in use in a particular country is likely to be fewer than eight.

5 Requirements

5.1 General requirements

The general requirements listed below are considered to be design guidelines for manufacturers.

- a) Given the likelihood that multiple insulin concentrations and concentration-specific syringes will exist in a particular country or locality, the manufacturer shall develop risk mitigation strategies to minimize the occurrence of “wrong dose” medication errors.
- b) The syringe shall indicate, through visual means, the insulin concentration it is intended to contain.
The insulin syringes should also indicate, through non-visual means (e.g. tactile), the insulin concentration it is intended to contain.
- c) Syringes designed to contain a specific concentration of insulin (e.g. U-100) shall be adequately differentiated visually from other dedicated syringes. This differentiation shall be determined based on a risk assessment and confirmed through usability validation testing.
- d) The syringe and needle should be free from defects affecting safety, serviceability for their intended use, and appearance.
- e) The syringe scale shall be graduated in increments corresponding to units of only one concentration of insulin. The syringe scale graduation and numbering increments shall be determined through risk analysis and confirmed through usability validation testing.

NOTE 1 [Annex H](#) offers guidance from prior versions of ISO 8537 for graduation and numbering increments on U-40 and U-100 syringes.

- f) The nominal capacity of the syringe shall be designated in millilitres (ml).
- g) The tolerances on the graduated capacity shall be in accordance with [Table H.1](#).

ISO 8537:2016(E)

- h) Syringes indicated for use with devices or accessories that provide automated functions (e.g. needle insertion and retraction) shall comply with applicable requirements of ISO 11608-1 and ISO 11608-5.
- i) Syringes with integrated or add-on sharps protection shall comply with ISO 23908.
- j) Syringes with Luer attachment features shall comply with ISO 80369-7.
- k) The length of the barrel shall be sufficient to allow the expulsion of any air bubbles without affecting the syringe's nominal capacity.

NOTE 2 Compliance with this requirement may be demonstrated, for example, by meeting the requirements in [5.6.1](#).

- l) The syringe's finger grips shall be of adequate size, shape and strength for the intended purpose. The design specifications for the finger grips shall be determined through risk analysis and confirmed through usability validation testing.
- m) The materials used in the syringe shall be tested and qualified according to ISO 10993-1.
- n) The self-contained syringes with sterile interiors and syringes provided in its unit packaging shall have been subjected to a validated sterilization process.

NOTE 3 For testing these properties, the manufacturer may use an extract, as specified in [Annex G](#).

5.2 Material selection

With regard to material selection,

- materials used for fabrication of the syringe barrel shall be of sufficient clarity to enable dosages to be read and for air bubbles to be seen without difficulty, and
- materials used for fabrication of syringes and needles (including lubricant) and packaging shall not, in their final form after sterilization and under conditions of intended use, adversely affect the efficacy, safety and acceptability of insulin preparations. The fabrication materials shall also not be affected, either physically or chemically, by insulin preparations.

5.3 Colour coding

Colour coding of syringes intended for dedicated use with specific insulin concentrations is as follows.

- The barrel of the insulin syringe shall be clear, with graduation markings of a colour that contrasts clearly with the syringe.
- The colour used to indicate the insulin concentration shall appear on at least one component of the syringe (e.g. needle cap, plunger cap, plunger, a portion of the barrel that does not interfere with visibility of the graduation lines).
- For insulin syringes with fixed needles, the colour of the needle cap shall be the colour designated for the insulin concentration.
- The colour coding used on the syringes shall be repeated and explained on the user packaging and, if applicable, on the unit packaging.

NOTE 1 The presence of colour coding on a syringe or package does not absolve the user of the responsibility to check the marked insulin concentration of the syringe.

- No additional colours, other than black and white, shall be used on the syringe barrel.

NOTE 2 In acknowledgement that established syringes on the market use red to indicate the U40 insulin strength on the barrel, these syringes are exempted.

- The dedicated colours used to indicate insulin concentration shall be the following:
 - red for U40;
 - orange for U100.

The following colours are given in order to prevent regional variation and to prevent the use of the same colour for different concentrations and different colours for the same concentration:

- light blue U200;
- yellow for U300;
- purple for U400;
- green for U500.

For the newly introduced colours and for any new colour selected, the complete information provided for the user shall be assessed for risk according to ISO 14971 and for usability according to IEC 62366-1.

NOTE 3 These colour restrictions do not apply to detachable needles.

5.4 Extraneous matter

5.4.1 General

The surfaces of the syringe and needle that come in contact with insulin shall be clean and free from extraneous matter.

NOTE Compliance with this requirement will be determined through inspection by an individual with normal vision (or corrected-to-normal vision), without magnification.

5.4.2 Limits for acidity or alkalinity

Exposure of distilled water to the finished syringe product shall not change its pH value by more than one unit.

Compliance with this requirement may be demonstrated by preparing the solutions described in [Annex A](#). The results shall show that the pH value of the syringe assessment fluid is within one pH unit of the pH value of the control fluid.

NOTE The pH value of both solutions may be determined with a laboratory potentiometric pH meter using a general purpose electrode.

5.4.3 Limits for extractable metals

Exposure of distilled water to the finished syringe product shall not change its content of metals by more than a combined total of 5 mg/kg of lead, tin, zinc and iron; the cadmium content shall be less than 0,1 mg/kg.

Compliance with this requirement may be demonstrated by preparing the solutions described in [Annex A](#) and testing them using a recognized micro-analytical method, for example, by an atomic absorption method.

5.5 Lubrication

5.5.1 Lubrication of syringes

If the interior surfaces of the syringe, including the plunger stopper, are lubricated, the lubricant shall not form pools of fluid on the interior surface of the syringe.

5.5.2 Lubrication of needle tube

If the needle tube is lubricated, the lubricant shall not be visible to an individual with normal or corrected-to-normal vision as droplets of fluid on the outside surfaces of the needle tube.

5.6 Dimensions

5.6.1 Barrel and plunger stopper

The barrel length shall be such that the syringe has a usable capacity of either 10 % more than the nominal capacity or 3 mm of plunger travel beyond the scale marking, whichever is less.

5.6.2 Finger grips

The open end of the barrel shall be provided with finger grips that prevent the syringe from rolling when the axis of the barrel is placed perpendicular to the incline of a flat surface angled at 10° from horizontal.

5.7 Plunger/plunger stopper

5.7.1 General

The design of the plunger and push-button on the end of the plunger shall be such that when the barrel is held in one hand, the plunger can be depressed by the thumb of that hand. The plunger stopper shall not become detached from the plunger during the test described in [Annex B](#).

The projection of the plunger and the configuration of the push-button should be such as to enable the plunger, when in the fully inserted position, to be grasped and drawn back without difficulty.

5.7.2 Fit of plunger stopper in barrel

When the syringe is filled with water and then held in both vertical orientations (i.e. with the needle end either up or down), the plunger shall not move by the force of gravity acting on the combined mass of the plunger and the water in the barrel. When a needle is secured to the syringe in accordance with the instructions provided by the manufacturer, the force required to initiate movement of the plunger to expel water from the syringe shall not exceed 15 N.

NOTE Compliance with this requirement can be demonstrated using the procedures described in [Annex C](#).

The fit of the plunger stopper in the barrel should be such that the plunger stopper slides smoothly throughout the full range of its travel within the barrel.

5.8 Nozzle

5.8.1 Conical fitting

The male conical fitting of the syringe nozzle on syringe types 1, 2, 3 and 4 shall comply with the requirements of ISO 594-1.

5.8.2 Position of nozzle on end of barrel

The syringe nozzle shall be situated centrally, i.e. shall be co-axial with the barrel.

5.9 Needle tubing and needles

5.9.1 Needles for syringe types 3 and 4

Needles for syringe types 3 and 4 shall be in accordance with ISO 7864.

5.9.2 Needle tubing for syringe types 5, 6, 7 and 8

Needle tubing for syringe types 5, 6, 7 and 8 shall be in accordance with ISO 9626.

The needle point shall be in accordance with ISO 7864.

The needle length shall be measured as shown in [Figure 1](#) and the tolerance of the needle length shall be within $\pm 1,25$ mm.

5.9.3 Bond between hub and needle tube

The bond between the hub and needle tube shall withstand at least the shearing forces shown in [Table 1](#).

Table 1 — Minimum strength of bond between hub and needle tube for different needle sizes

Nominal outside diameter of needle (mm)	Minimum shearing strength
$\geq 0,33$	22 N (5 lbs)
$< 0,33$	11 N (2,5 lbs)

5.10 Standard test environmental conditions

Unless otherwise specified, measurements shall be performed under the following atmospheric conditions:

- temperature between 18 °C and 28 °C;
- relative humidity between 25 % RH and 75 % RH.

Testing shall be performed after samples have been stored under these conditions for at least 4 h.

5.11 Performance of assembled syringe

5.11.1 Dead space

Dead space should be minimized to reduce waste and transmission of infectious agents.

The dead space shall not exceed the limits given in [Table 2](#).

NOTE Compliance with this requirement may be demonstrated using the methods described in [Annex D](#).

Table 2 — Maximum dead space

Type of syringe	Maximum dead space (ml)
1 and 2	0,07
3 and 4	0,10
5 and 6	0,02
7 and 8	0,01

5.11.2 Freedom from leakage at needle

There shall be no leakage of water sufficient to form a falling drop within 30 s from the junction point between the syringe nozzle and the needle hub or the junction point between the syringe and the needle tube, as appropriate.

NOTE 1 Compliance with this requirement may be demonstrated using the method described in [Annex E](#).

There shall be no continued formation of air bubbles from the junction point between the syringe nozzle and the needle hub or the junction point between the syringe and the needle tube, as appropriate.

NOTE 2 Compliance with this requirement may be demonstrated using the method described in [Annex F](#).

5.11.3 Freedom from leakage past plunger stopper

There shall be no leakage of water past the piston seal.

NOTE 1 Compliance with this requirement may be demonstrated using the method described in [Annex E](#).

There shall be no leakage of air past the plunger stopper seal and there shall be no drop in the manometer reading.

NOTE 2 Compliance with this requirement may be demonstrated using the method described in [Annex B](#).

6 Packaging

6.1 Unit packaging and self-contained syringe units

6.1.1 General

Syringe types 1, 3, 5 and 7 shall be packaged in unit packaging and syringe types 2, 4, 6 and 8 shall be packed as self-contained syringes.

6.1.2 Unit packaging providing sterile barrier syringes (types 1, 3, 5 and 7)

The syringe, together with the needle if supplied, shall be sealed individually in unit packaging that provides and maintains a sterile barrier.

For syringe types 3, 5 and 7, the needle shall be supplied with a protective needle cap.

The needles of type 3 syringes may be packaged in separate packaging inside the unit packaging.

The materials and design of the unit packaging should have no adverse effects on the contents and should ensure the following:

- a) maintenance of sterility of the contents under dry, clean and adequately ventilated storage conditions;
- b) minimum risk of contamination of the contents during opening and removal from the packaging;
- c) adequate protection of the contents during normal handling, transit and storage;
- d) once opened, the packaging cannot be easily re-sealed and it shall be obvious that the packaging has been opened.

6.1.3 Self-contained syringes with sterile interiors (types 2, 4, 6 and 8)

The syringe shall be fitted with a needle cap and a plunger cap.

The materials and design of the self-contained syringe shall ensure the following:

- a) maintenance of sterility of the interior of the syringe unit (i.e. the needle, the protruding part of the plunger and its push-button, and the fluid path of the syringe and of the needle, if fitted) under dry, clean and adequately ventilated conditions;
- b) minimum risk of contamination of the covered components (i.e. the needle, the protruding part of the plunger and its push-button) during removal of the end caps;
- c) adequate protection of the fluid path of the syringe and of the needle, if fitted during normal handling, transit and storage.

NOTE The self-contained syringe may provide a means of detecting that the end caps were removed previously.

6.2 Multiple-unit packaging (for syringe types 2, 4, 6 and 8)

The materials and design of multiple-unit packaging shall ensure the following:

- a) minimum risk of contamination of a single self-contained syringe during opening of the packaging;
- b) adequate protection of the self-contained syringes during normal handling, transit and storage.

6.3 User packaging

Multiple items of unit packaging, self-contained syringes, or multiple-unit packaging shall be packed in user packaging.

The user packaging system shall provide physical protection of the syringes and maintain the integrity of the sterile barrier system during normal handling, transit, and storage for the duration of the shelf life or until the expiration date.

7 Information supplied by the manufacturer

7.1 General

The syringe shall be accompanied by the information that are sufficient for its safe use, taking account of the training and knowledge of potential users.

The information shall include the identity of the manufacturer.

7.2 Syringes

7.2.1 General

The barrels of syringes shall be marked with the following information:

- a) an appropriate graduated scale in accordance with [Annex H](#);
- b) a text indicating the insulin concentration for which the syringe was designed to hold, e.g. the text “U-40 insulin” or “U-100 insulin”;
- c) the word “units” or “I.U.”;
- d) the total graduated capacity of the syringe, in millilitres.

7.2.2 Additional marking for self-contained syringes (syringe types 2, 4, 6 and 8)

The self-contained syringe shall additionally be marked with the following information in accordance with ISO 15223-1:2012, Table 1:

- a) the words “for single use” or equivalent, such as the symbol for “do not reuse”; the term “disposable” shall not be used;

NOTE 1 See ISO 15223-1:2012, Table 1, symbol number 5.4.2.

- b) the name and/or trade-mark of the manufacturer or authorized representative.

NOTE 2 A warning to check the integrity of the seals of the self-contained syringe before use may be given.

All information that appears on the barrel should be marked in such a position as to interfere as little as possible with the reading of the graduated scale.

7.3 Unit packaging (for syringe types 1, 3, 5 and 7)

The unit packaging shall be marked with the following information in accordance with ISO 15223-1:2012, Table 1:

- a) the word “sterile” or equivalent; such as symbol for “Sterile”;

NOTE 1 See ISO 15223-1:2012, Table 1, symbol number 5.2.1 or symbol numbers 5.2.2 to 5.2.5, which indicate the specific sterilization method used.

- b) the words “for single use” or equivalent, such as the symbol for “do not reuse”; the term “disposable” shall not be used;

NOTE 2 See ISO 15223-1:2012, Table 1, symbol number 5.4.2.

NOTE 3 A warning to check the integrity of the unit packaging before use may be given, such as using the symbol from ISO 15223-1:2012, Table 1, symbol number 5.2.8, “Do not use if package is damaged”.

- c) an identifying reference to the batch code or lot number, preceded by the symbol for “batch code” or the word “LOT”;

NOTE 4 See ISO 15223-1:2012, Table 1, symbol number 5.1.5.

- d) the external diameter and length of the needle in millimetres, if included; the gauge size of the needle may also be marked.

The unit packaging shall also be marked with the following information unless the product is marked with the information and it is visible through the unit packaging:

- e) a description of the contents, including the capacity of the syringe and the concentration of insulin to be used;

- f) the name and/or registered trade-mark of the manufacturer or authorized representative;

- g) the words “EXP” or equivalent, such as the symbol for “expiration date”.

NOTE 5 See ISO 15223-1:2012, Table 1, symbol number 5.1.4.

7.4 Multiple unit packs (syringe types 2, 4, 6 and 8)

The multiple unit packs shall be marked with the following information in accordance with ISO 15223-1:2012, Table 1:

- a) the words “syringe interior sterile” or equivalent, such as the symbol for “sterile fluid path”;

NOTE 1 See ISO 15223-1:2012, Table 1, symbol number 5.2.9.

- b) a warning to check the integrity of the seals of the self-contained syringe units before use, unless this warning is given on the syringe unit;

NOTE 2 See ISO 15223-1:2012, Table 1, symbol number 5.2.8, “Do not use if package is damaged”.

- c) the words “for single use” or equivalent, such as the symbol for “do not reuse”; the term “disposable” shall not be used;

NOTE 3 See ISO 15223-1:2012, Table 1, symbol number 5.4.2.

- d) the name and/or trade-mark of the manufacturer or authorized representative unless the product bears this information and it is visible through the multiple unit pack;

- e) an identifying reference to the batch code or lot number, preceded by the symbol for “batch code” or the word “LOT”;

NOTE 4 See ISO 15223-1:2012, Table 1, symbol number 5.1.5.

- f) the external diameter and length of the needle in millimetres, if included; the gauge size of the needle may also be marked;

- g) a description of the contents, including the capacity of the syringe and the concentration of insulin to be used unless the information is visible through the multiple unit pack;

- h) the words “EXP” or equivalent, such as the symbol for “expiration date”.

NOTE 5 See ISO 15223-1:2012, Table 1, symbol number 5.1.4.

7.5 User packaging

The user packaging shall be marked with the following information in accordance with ISO 15223-1:2012, Table 1:

- a) the word “sterile” or equivalent, such as the symbol for “sterile”;

NOTE 1 See ISO 15223-1:2012, Table 1, symbol number 5.2.1 or 5.2.2 to 5.2.5, which indicate the specific sterilization method used.

- b) for self-contained syringes, the words “syringe interior sterile” or equivalent, such as the symbol for “sterile fluid path”, as appropriate to the type of syringe in the packaging;

NOTE 2 See ISO 15223-1:2012, Table 1, symbol number 5.2.9.

- c) a warning, as appropriate to the type of syringe contained, to check the integrity of the unit packaging or of the seals of the self-contained syringe unit before use, unless this warning is given on the unit packaging or syringe unit;

NOTE 3 See ISO 15223-1:2012, Table 1, symbol number 5.2.8, “Do not use if package is damaged”.

- d) the words “for single use” or equivalent, such as the symbol for “do not reuse”; the term “disposable” shall not be used;

NOTE 4 See ISO 15223-1:2012, Table 1, symbol number 5.4.2.

- e) an identifying reference to the batch code or lot number, preceded by the symbol for “batch code” or the word “LOT”.

NOTE 5 See ISO 15223-1:2012, Table 1, symbol number 5.1.5.

- f) the name and/or registered trade-mark of the manufacturer or authorized representative;

- g) a description of the contents;

- h) the words “EXP” or equivalent, such as the symbol for “expiration date”.

NOTE 6 See ISO 15223-1:2012, Table 1, symbol number 5.1.4.

7.6 Storage container

If user packaging is packaged in a storage container, the storage container shall be marked with at least the following information in accordance with ISO 15223-1:2012, Table 1:

- a) a description of the contents including the capacity of the syringe and the concentration of insulin to be used;
- b) an identifying reference to the batch code or lot number, preceded by the symbol for “batch code” or the word “LOT”;

NOTE 1 See ISO 15223-1, Table 1, symbol number 5.1.5.

- c) the word “STERILE” or equivalent, such as the symbol for “sterile”;

NOTE 2 See ISO 15223-1:2012, Table 1, symbol number 5.2.1, or symbol numbers 5.2.2 to 5.2.5, indicate the sterilization method used.

- d) the name and address of the manufacturer or authorized representative;
- e) the information related to safe handling, storage and transportation of the contents;

NOTE 3 An indication to keep the storage container away from sunlight and keep dry may be given. See ISO 15223-1:2012, Table 1, symbol numbers 5.3.2 and 5.3.4.

- f) the words “EXP” or equivalent, such as the symbol for “expiration date”.

NOTE 4 See ISO 15223-1:2012, Table 1, symbol number 5.1.4.

- g) for self-contained syringes, the words “syringe interior sterile” or equivalent, such as the symbol for “sterile fluid path”, as appropriate to the type of syringe in the packaging.

NOTE 5 See ISO 15223-1:2012, Table 1, symbol number 5.2.9.

7.7 Transport wrapping

If a storage container is not used but the user packaging is wrapped for transportation, the information required by [7.6](#) shall either be marked on the outside of the wrapping or shall be visible through the wrapping.

Annex A

(normative)

Fluid for determination of acidity/alkalinity and extractable metals

A.1 Syringe assessment fluid preparation

Fill 10 sterile syringes, including the needle if supplied, to the nominal capacity with freshly prepared distilled water, and maintain them at $37\text{ °C} \pm 3\text{ °C}$ for 8 h.

Eject the contents of the ten syringes and combine them in a single vessel made of borosilicate glass.

A.2 Control fluid preparation

Prepare the control fluid by reserving an aliquot of the same, but unused, distilled water used to prepare the syringe assessment fluid.

Annex B (normative)

Test method for air leakage past syringe piston during aspiration and for separation of rubber stopper and plunger

B.1 Principle

Connect the syringe nozzle to a compatible connection and fill the syringe with water. Apply a negative pressure through the nozzle and inspect the syringe for leakage past the piston and seal(s) and to determine if the rubber stopper has become detached from the plunger.

B.2 Apparatus and reagents

The following equipment and reagents are needed for this testing.

B.2.1 Tubing set with compatible conical fitting, in accordance with ISO 594-1.

B.2.2 Support and device that clamp the syringe plunger in a fixed position.

B.2.3 Equipment for producing, controlling and measuring a vacuum, comprising a vacuum generator, a manometer and a vacuum-tight valve system. Different configurations of such equipment are possible, with syringe nozzle oriented upwards or downwards (see [Figure B.1](#)).

B.2.4 Distilled water, complying with grade 3 of ISO 3696, at a temperature between between 18 °C and 28 °C.

B.3 Procedure

B.3.1 Fill the syringe with distilled water ([B.2.4](#)) to at least 25 % of the syringe's nominal capacity.

B.3.2 Withdraw the piston axially until the fiducial line is at the nominal graduated capacity and clamp ([B.2.2](#)) the plunger in this position.

B.3.3 Connect the syringe nozzle to a reference steel, female, conical fitting, as specified in ISO 594-1. If the needle is attached by a method other than the use of a 6 % (Luer) conical fitting, insert the needle into the rubber bung or diaphragm fitted into the female conical fitting.

B.3.4 Generate the vacuum.

B.3.5 Adjust the pressure control so that a gradual reduction in pressure is obtained and a manometer reading of 88 kPa below ambient atmospheric pressure is reached.

NOTE 1 kPa = 7,5 mmHg.

B.3.6 Examine the syringe for evidence of air leakage past the rubber stopper or seal(s).

B.3.7 Isolate the syringe and manometer assembly by means of a vacuum-tight valve.

B.3.8 Observe the manometer reading for 60 s and record any drop in the reading.

B.3.9 Examine the syringe to determine if the rubber stopper has become detached from the plunger.

B.4 Test report

The following information shall be provided:

- the identity of the syringe;
- the date of testing;
- a statement as to whether air leakage (B.3.6 and B.3.8) was observed;
- a statement as to whether the plunger stopper detached from the plunger (B.3.9).

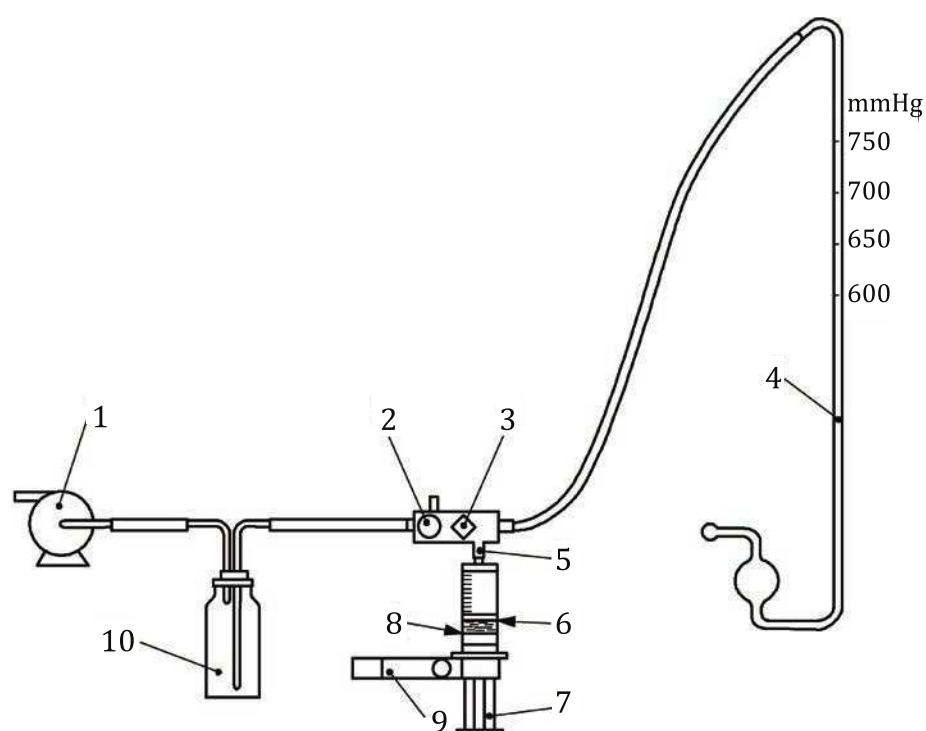

Key

1	vacuum pump	6	25 % H ₂ O volume
2	fine bleed control	7	syringe
3	vacuum tight valve	8	nominal capacity
4	manometer	9	clamp
5	ISO 594-1 female conical fitting mount or rubber bung	10	bottle trap

NOTE 1 The volume of air enclosed between the syringe tip and the manometer should be as small as possible.

NOTE 2 The apparatus can be used for all types of syringes, as the apparatus can be fitted with either a female conical fitting or a rubber bung.

Figure B.1 — Apparatus used in aspiration test

Annex C (normative)

Test method for determination of forces required to operate piston

C.1 Principle

A mechanical testing machine is used to expel water from a syringe and simultaneously record the force required to move the piston.

C.2 Apparatus and reagents

The following equipment and reagents are needed for this testing.

C.2.1 Mechanical testing machine, as shown in [Figure C.1](#), capable of attachment to the syringe under test and of depressing the syringe piston at a constant linear rate, while simultaneously continuously measuring and recording the force required to move the piston, with an accuracy of 1 % of full-scale reading

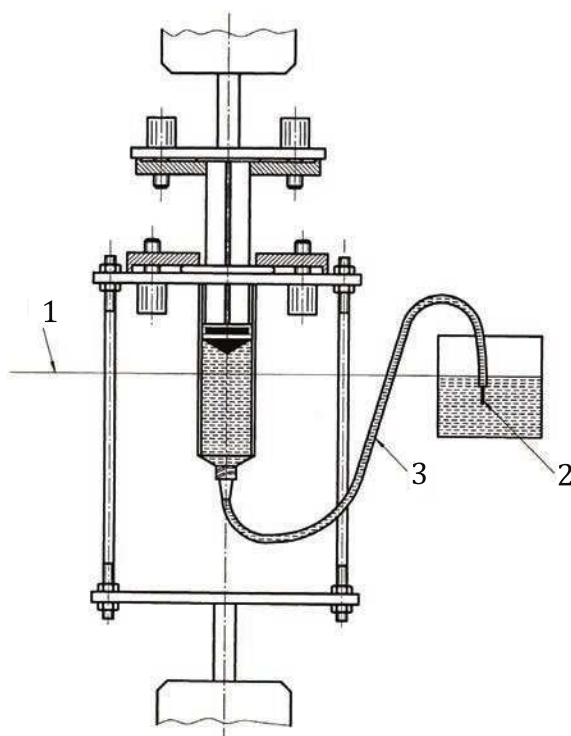

Key

- 1 water level adjusted to align with the graduation mark at 50 % of the nominal capacity of the syringe
- 2 needle [1,2 mm (18G) × approximately 10 cm length]
- 3 administration set (1,2 mm i.d. × 1 m polyethylene tubing)

NOTE For syringe types 7 and 8, the needle and the administration set are replaced by the syringe.

Figure C.1 — Apparatus for determining forces required to operate plunger

C.2.2 Distilled water, complying with grade 3 of ISO 3696.

C.3 Procedure

C.3.1 Attach the needle to the syringe, if not already fitted. Syringe types 1 and 2 shall be fitted with a needle with an external diameter of 0,40 mm.

C.3.2 Fill the syringe with distilled water ([C.2.2](#)) to 50 % of its nominal capacity.

C.3.3 Clamp the syringe onto a suitable test stand ([C.2.1](#)) with the needle pointing downward.

C.3.4 Wipe away any water from the needle point.

C.3.5 Immediately apply a vertical downward force to the plunger by means of a force gauge and gradually increase the force until the plunger begins to move the initiation of movement being indicated by the expulsion of water from the needle.

C.3.6 Maintain a force sufficient to sustain the plunger movement until it is fully depressed.

C.4 Test report

The following information shall be provided:

- a) the identity of the syringe;
- b) the date of testing;
- c) the force required to initiate movement of the piston ([C.3.5](#)), expressed in newtons;
- d) a record of the maximum force required to operate the plunger during the test.

Annex D (normative)

Test method for determination of dead space

D.1 Preparation of samples

D.1.1 Syringe types 3 and 4

Remove the needle, if fitted, from the syringe and then refit it as follows.

Connect the nozzle of the syringe to the needle hub. Assemble the components by applying an axial force of 27,5 N for 5 s while applying a twisting action to a torque value not exceeding 0,1 Nm to give rotations not exceeding 90°.

D.1.2 Syringe types 1, 2, 5, 6, 7 and 8

No preparation is necessary.

D.2 Procedure

D.2.1 Weigh the empty syringe, including needle if appropriate, prepared in accordance with [E.1](#), with an accuracy of 0,001 g.

D.2.2 Fill the syringe to the total graduated capacity with distilled water at a temperature of 18 °C to 28 °C, taking care to expel all air bubbles, especially from the needle, if present, and in the case of syringes without a needle, ensure that the level of the meniscus coincides with the end of the nozzle lumen.

D.2.3 Expel the water by fully depressing the plunger, and wipe dry the outer surface of the syringe.

D.2.4 Reweigh the syringe.

D.2.5 Determine the mass of water, in grams, remaining in the syringe by subtracting the mass of the empty syringe from the mass of the syringe after expulsion of the water. Record this value as the dead space in millilitres, taking the density of water as 1 000 kg/m³.

D.3 Test report

The following information shall be reported:

- a) the identity of the syringe;
- b) the date of testing;
- c) the dead space volume of the syringe ([D.2.5](#)), expressed in millilitres.

Annex E (normative)

Test method for liquid leakage at syringe piston and syringe nozzle/hub or needle/barrel unions during compression

E.1 Preparation of samples for testing

E.1.1 Testing for leakage past piston

E.1.1.1 Syringe types 1 and 2

Connect the syringe nozzle to a reference steel, female, conical fitting, in accordance with ISO 594-1. Assemble the components by applying an axial force of 27,5 N for 5 s while applying a twisting action to a torque value not exceeding 0,1 N·m to give rotation not exceeding 90°.

E.1.1.2 Syringe types 3 and 4

Remove the needle, if fitted, and connect the syringe nozzle to a reference steel, female, conical fitting, as described in [E.1.1.1](#).

E.1.1.3 Syringe types 5 and 6

Ensure that the junction between the syringe nozzle and the needle hub is securely connected and does not leak.

E.1.1.4 Syringe types 7 and 8

No preparation is necessary.

E.1.2 Testing for leakage at syringe nozzle

E.1.2.1 Syringe types 1 and 2

Connect the syringe to a reference steel, female, conical fitting, as described in [E.1.1.1](#).

E.1.2.2 Syringe types 3 and 4

Remove the needle, if fitted, and connect the syringe nozzle to a reference steel, female, conical fitting, as described in [E.1.1.1](#).

E.1.2.3 Syringe types 5 and 6

No preparation is necessary.

E.1.2.4 Syringe types 7 and 8

No preparation is necessary.

E.2 Procedure

E.2.1 Fill the syringe with a volume of water that exceeds the graduated capacity of the syringe. If the junction point between the syringe nozzle and the reference steel, female, conical fitting, or the junction point between the syringe and the needle tube, becomes wetted, dry the junction point.

E.2.2 Expel all air from the syringe.

E.2.3 Adjust the volume of water in the syringe to the maximum graduated capacity.

E.2.4 Seal the reference steel female conical fitting, or needle tip, as applicable.

E.2.5 Apply a side load equivalent to a force of 0,25 N to the push-button at right angles to the axis of the plunger to swing the plunger radially about the piston seal(s). Orient the plunger to permit the maximum deflection from the axial position.

E.2.6 Apply an axial force to the syringe so that a pressure is generated by the relative action of the piston and barrel of 300 kPa gauge. Maintain the pressure for 30 s.

E.2.7 Examine the syringe to detect and record any piston movement in the period during which pressure was applied.

E.2.8 Examine the syringe for leakage of liquid past the piston seals.

E.2.9 Examine the junction point between the syringe nozzle and the reference steel female conical fitting or needle hub or the junction point between the syringe and the needle tube, as applicable, for evidence of leakage of liquid.

E.3 Test report

The following information shall be provided:

- a) the identity of the syringe;
- b) the date of testing;
- c) a statement as to whether leakage past the piston was observed ([E.2.8](#));
- d) a statement as to whether leakage was observed ([E.2.9](#)).

Annex F (normative)

Test method for air leakage past nozzle/hub or needle/barrel unions during aspiration

F.1 Preparation of samples

Prepare samples for testing as described in [E.1](#).

F.2 Procedure

F.2.1 Fill the syringe with a volume of distilled water to at least 25 % of the nominal graduated capacity of the syringe. If the junction point between the syringe nozzle and the reference steel female conical fitting, or the junction point between the syringe and the needle tube, becomes wetted, dry the junction point.

F.2.2 Expel all air from the syringe, except for a small residual air bubble.

F.2.3 Adjust the volume of water in the syringe to 25 % of the nominal graduated capacity.

F.2.4 Seal the reference steel female conical fitting or needle tip, as applicable.

F.2.5 With the syringe nozzle downwards, withdraw the plunger to the total graduated capacity line. Hold the plunger for 15 s.

F.2.6 Examine the syringe for the continued formation of air bubbles from the junction point between the syringe nozzle and the reference steel female conical fitting or needle hub, or from the junction point between the syringe and the needle tube, as applicable.

Do not record any bubbles that appear during the first 5 s.

F.3 Test report

The following information shall be provided:

- a) the identity of the syringe;
- b) the date of testing;
- c) a statement as to whether leakage was observed ([F.2.6](#)).

Annex G (normative)

Preparation of extract for test for pyrogenicity and toxicity

Prepare a pyrogen-free saline solution by combining of 9 g/l of sodium chloride (of recognized analytical quality) and distilled water.

Using sterile reagents and apparatus, and aseptic technique, fill at least three sterile syringes, including the needle, if supplied, to the syringes' nominal capacity with the saline solution, and maintain them at $37\text{ °C} \pm 3\text{ °C}$ for 8 h.

Eject the contents of all the syringes and combine them in a single vessel made of borosilicate glass.

Annex H (normative)

Syringe sizes and graduated scales

H.1 General

[Table H.1](#) provides examples of syringe graduation specifications for U-40 and U-100 syringes. They are based on previous versions of ISO 8537 and are provided as examples only. Ultimately, specifications for syringe graduations and numbering should be determined based on risk analysis and usability testing.

Table H.1 — Insulin syringes, range of sizes, graduated scale and tolerance on graduated capacity

Unit scale	Nominal capacity ml	Minimum length of scale mm	Scale interval units	Tolerance on graduated capacity	
				Volumes less than half the nominal capacity	Volumes equal to or greater than half the nominal capacity
U-100	0,3	41	0,5	±1,5 % of the nominal capacity +2 % of the expelled volume	±5 % of the expelled volume
	0,3	41	1		
	0,5	43	1		
	1,0	57	1		
	1,0	57	2		
U-40	0,5	43	0,5		
	0,5	43	1		
	1,0	50	1		
	2,0	60	1		
	2,0	60	2		

NOTE Syringes having different nominal capacities and scale intervals are designated to allow for different product types, but the number of types in use in a particular country can be fewer than the ones listed in [Table H.1](#).

H.2 Graduation lines

The graduation lines shall be of a uniform thickness between 0,2 mm and 0,4 mm. They shall lie in planes at right angles to the axis of the barrel.

The graduation lines shall be evenly spaced along the longitudinal axis between the zero line and the line that marks the total graduated capacity.

When the syringe is held vertically, the ends of all graduation lines of similar length shall be vertically aligned with the axis of the barrel and with each other, within a tolerance of ±0,5 mm.

The length of the short graduation lines shall be approximately half the length of the long graduation lines.

The scale and scale numbers should be legible and of a colour that contrasts clearly with the syringe.

H.3 Numbering of scale

The graduation lines shall be numbered

- at every five units for the 0,3 ml and 0,5 ml syringes, and
- at every 10 units for the 1,0 ml and 2,0 ml syringes.

The height of the numbers should be at least 3 mm.

When the syringe is held vertically with the zero line uppermost and with the scale to the front, the numbers shall appear upright on the scale and centred on the graduation lines to which they relate. The numbers shall be close to, but shall not touch, the ends of the graduation lines to which they relate.

Bibliography

- [1] ISO 81714-1, *Design of graphical symbols for use in the technical documentation of products — Part 1: Basic rules*
- [2] ISO 15223-2, *Medical devices — Symbols to be used with medical device labels, labelling, and information to be supplied — Part 2: Symbol development, selection and validation*

