



## **TSTY Electric Co., Ltd**

Factory Add: Xingye Road, Industry Cluster District, Jiaxian,  
Pingdingshan City, Henan Province, China

Tel:0086371-88881569      whatsapp: +86 158 9060 6007

E-mail:info@tstyelectric.com      Add:www.tstyelectric.com



# **TSTY Electric Co., Ltd**

TO BE THE WORLD-CLASS ELECTRIC MANUFACTURER



POWER AND TRANSFORM THE WORLD ELECTRICITY

# Production Equipment







# Honor Certificate

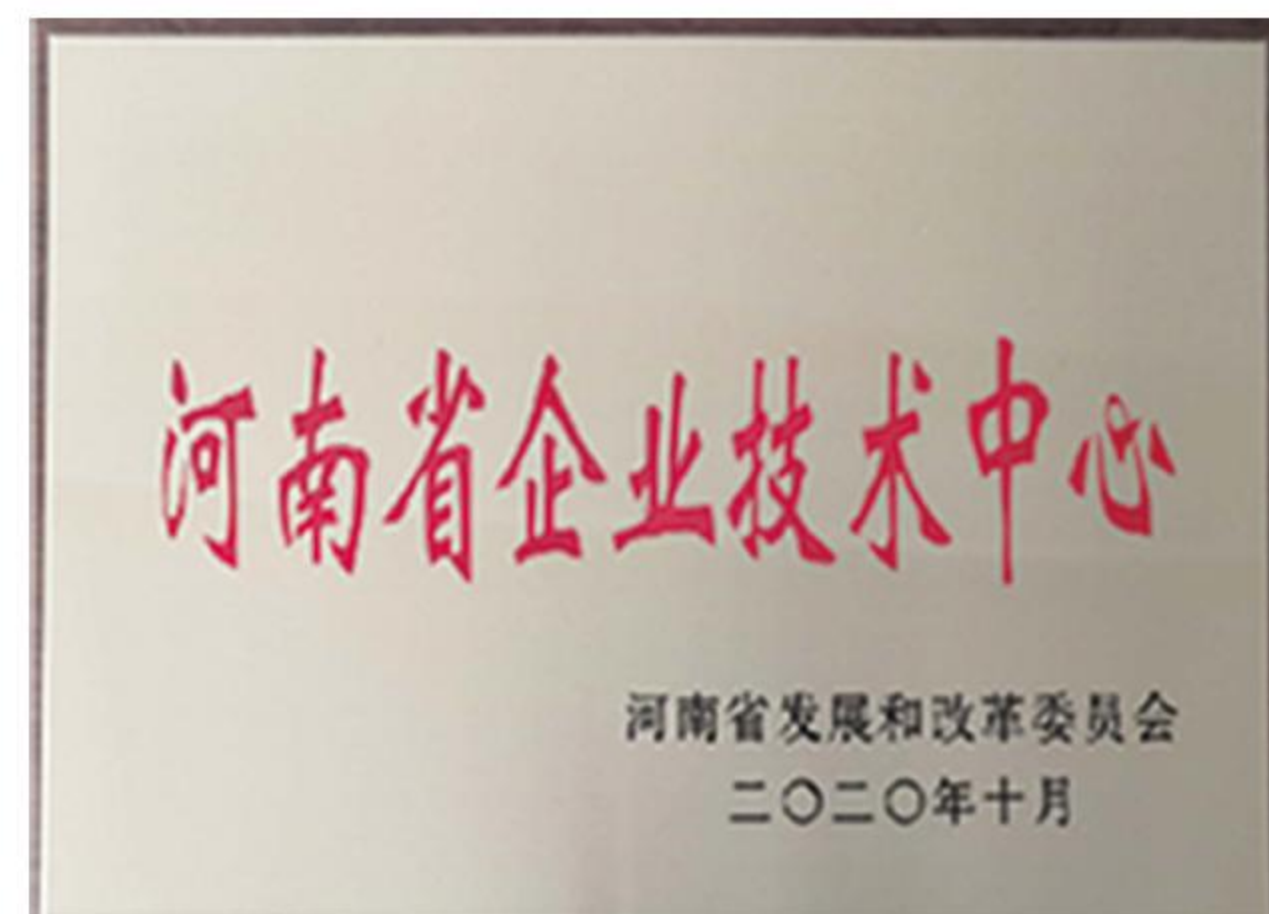
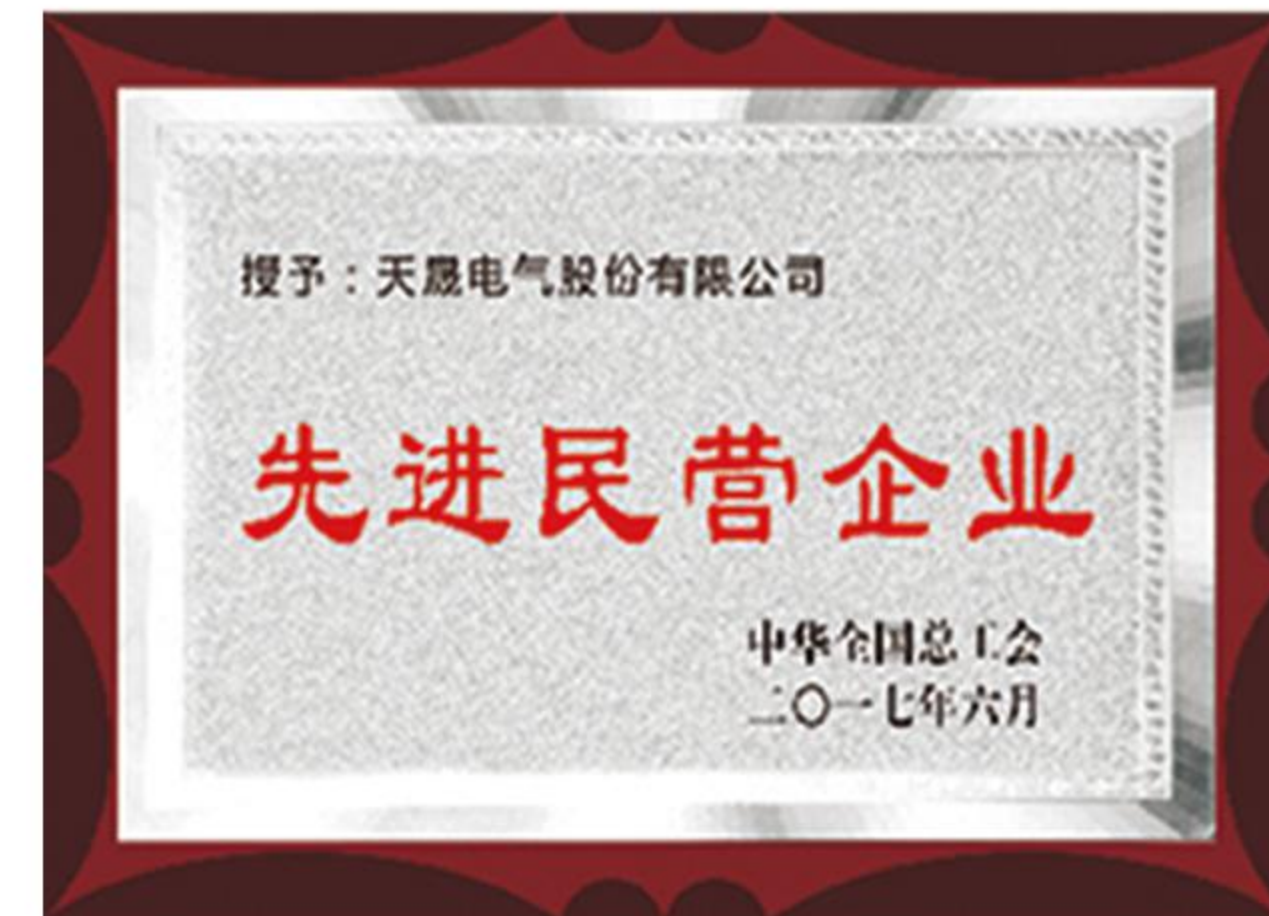

# OUR SERVICE

We put much importance on quality control and service. We believe quality is an habit not just an act. We aim to be the top manufacturer of distribution transformer in the whole China.

## Enterprise Profile

Established in 2005 and located at the Pingdingshan City, Henan Province of China, TSTY Electric Co., Ltd covers more than 200,000 square meters with the registered capital 101 million RMB(15 million USD). Now Company has established three factories. The company mainly develops and produces oil-immersed transformers, dry-type transformers, box-type substations and high and low voltage switchgears. The equipment put into production and operation of the project advocates energy saving, intelligence, information and mechanization.

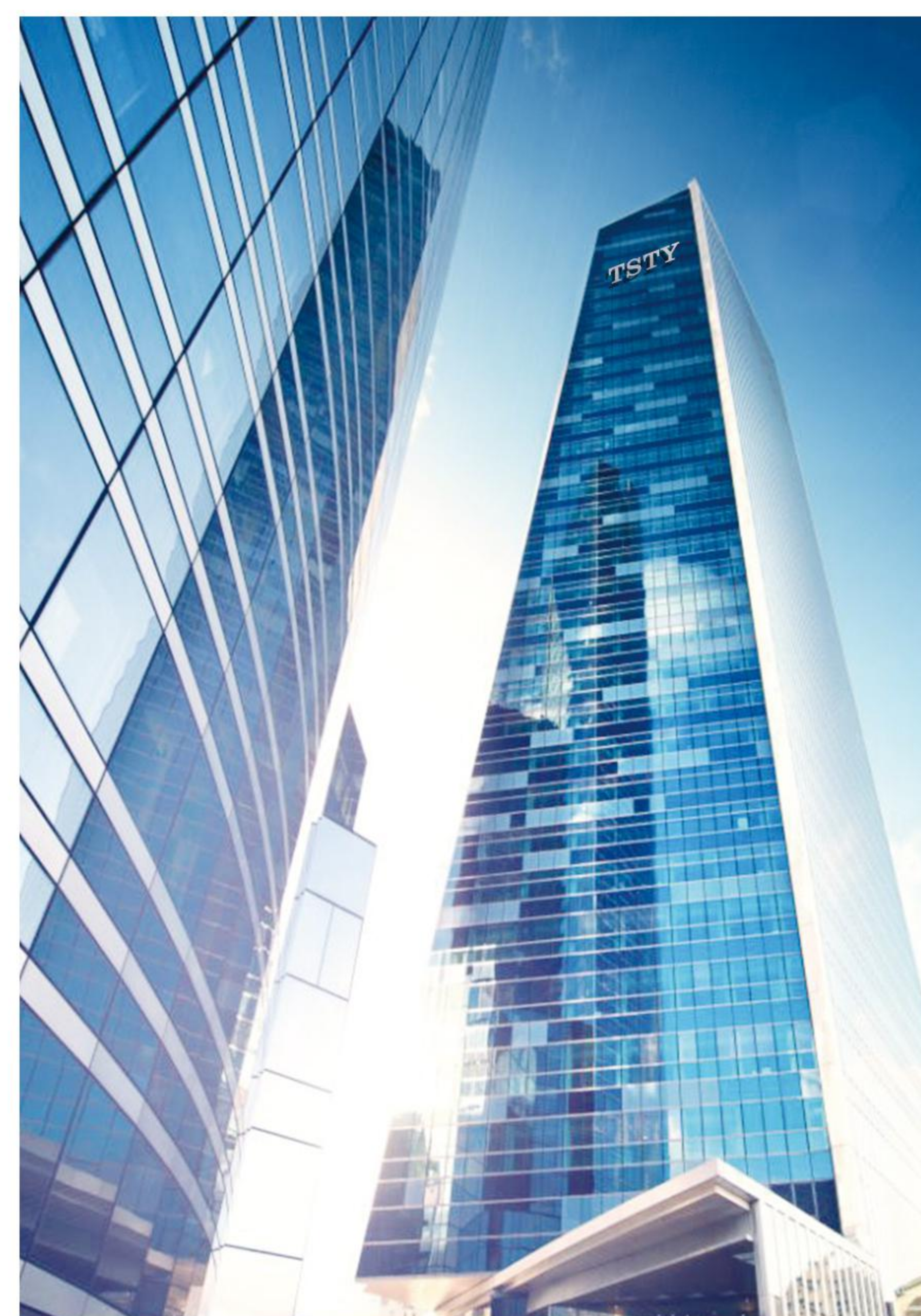

## Enterprise Layout

Now company has more than 550 employees, 186 senior engineers and R&D personnel. Prided with the national high-tech enterprise title, the company has obtained 71 utility model patents and 15 patents for inventions to 2018. The products are in accordance with ISO, IEC, CCC and SGS.

## About Us

### Opportunities come from major

As one of the largest electrical manufacturers in China, TSTY Electric Co., Ltd. is one important and reliable electric equipment supplier and partner in China and also in the world.

# DIRECTORY

## OIL IMMERSED TRANSFORMERS / 03

S9-M Type Oil Immersed Power Transformer	03
S11 Electric Oil Immersed Power Transformer	05
S11-M.ZT On-load Tap Changed (OLTC) Power Transformer with Adjustable Capacity	10
S13 Electric Oil Immersed Power Transformer	12
S13-MRL Series Three-dimensional Wound Core Power Transformer	14

## DRY TYPE TRANSFORMERS / 17

Dry Type Transformers SCB10 / SCB11/ SCB13	17
SG (B) 10 Series Non-encapsulated Dry-type Power Transformers	20

## TRANSFORMER SUBSTATION / 22

YB Preinstalled Type Transformer Substation (European Style)	22
ZGS Three-Phase Pad-Mountde -Compartmental Type Transformer	25
YB MV/LV Prefabricated Substation	26

## HIGH AND LOW VOLTAGE SWITCHGEARS / 29

GCS Low-Voltage Switchgear Panel, Withdrawable Type	29
GGD Low - Voltage Switchgear Panel,Fixed Type	31
HXGN-12 Series High Voltage Switchgears	33
KYN28A-12 (Z) Metalclad AC Enclosed Switchgear Witsdrawable Type	35



# OIL IMMERSED TRANSFORMERS

## S9-M Type Oil Immersed Power Transformer

The S9-M type transformer introduces new international technology, adopts a fully oil-filled sealed type, without an oil conservator, and the transformer changes its oil body due to changes in temperature and load, which is completely adjusted by the flexibility of the transformer tank. The no-load loss of the transformer is 30% lower than that of the S7 type, and it has strong lightning resistance and short-circuit resistance. The energy-saving effect is more better, and the outer size of the transformer is compact.



## Product Features

- 01 **Low noise**  
compact structure, application of new materials and new technology, reduce noise, no oil storage tank, lower height than similar products.

- 02 **Reliable long-term service life**  
The fully sealed transformer case cover and the tank rim are bolted or welded to isolate the contact between oil and air.
- 03 **Small size and perfect appearance**  
S9-M series transformer oil tanks use corrugated plate fins. When the oil temperature changes, the change in oil volume is adjusted and compensated by the elastic expansion and contraction of the corrugated sheets. The corrugated fuel tank is beautiful in appearance and small in size, with a small footprint.
- 04 **Maintenance-free**  
The fully sealed transformer does not require maintenance.

## Model Implication

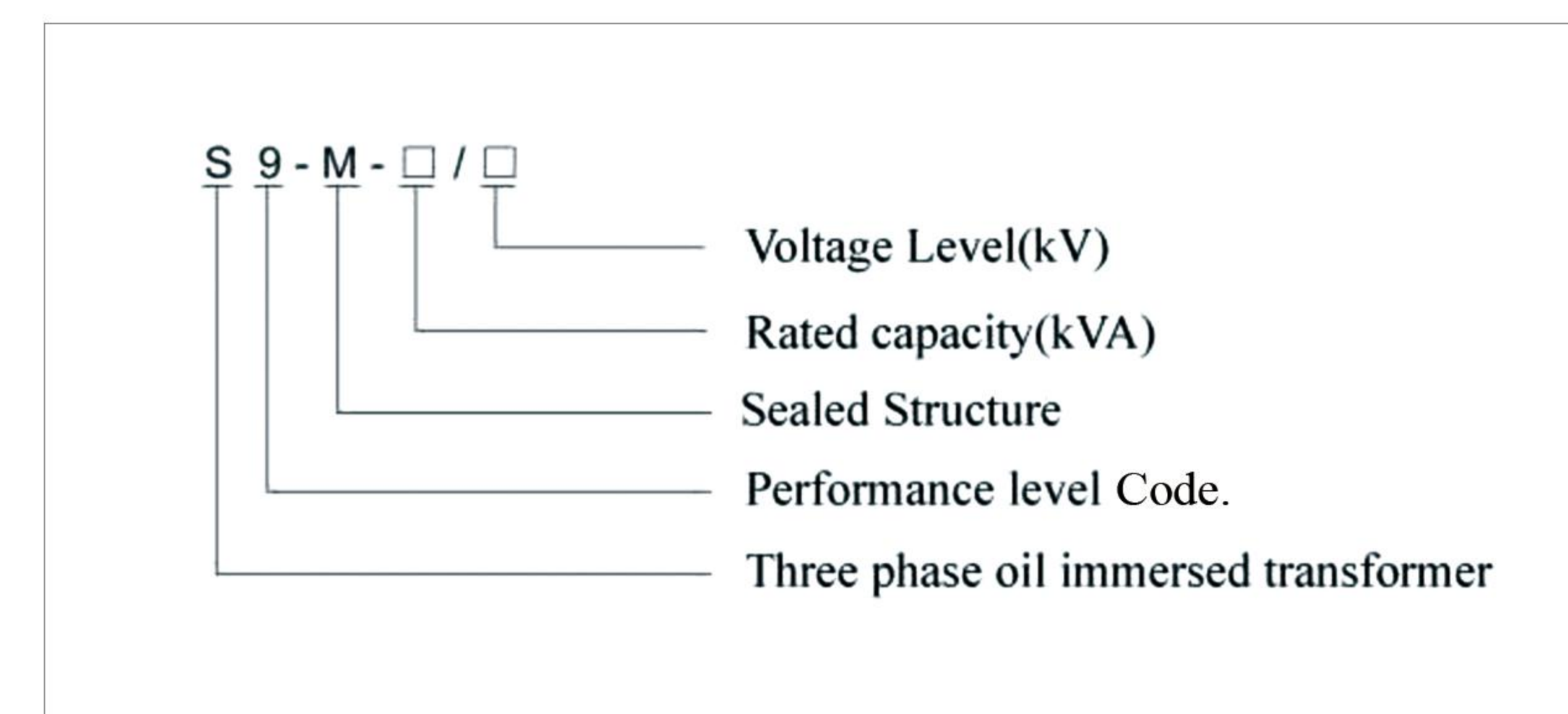

## Product Standard

- + IEC60076
- + GB/T 1094.1~2-1996 Power Transformer
- + GB/T 1094.3.5-2003 Power Transformer
- + GB/T6451-2008 Technical Parameters and Requirements for Three-phase Oil-immersed Power Transformers



## Applicable Environment

- + High ambient temperature: +40°C
- + Low ambient temperature: -25°C
- + Altitude: <1000m
- + Monthly average relative humidity: 90% (20°C)
- + Installation location: used in chemical plants, factories, remote places and harsh environment.

We can also customize according to your demand.

## Technical Parameter

Rated capacity (KVA)	Voltage			Connection group tab	Loss			Resistant voltage(%)	Weight(Kg)			Measure(mm) L*W*H
	High-voltage(kv)	Extend connection	Low-voltage(kv)		No-load(W)	Load(W)	No-load current (%)		Empty weight	Oil weight	Total weight	
30	6 6.3 10 10.5 11	±5% ±2*2.5%	0.4	Yyn0 Dyn11	130	600	2.1	4	150	88	320	780*480*890
50					170	870	2		208	99	430	780*635*905
63					200	1040	1.9		231	102	450	850*630*910
80					250	1250	1.8		256	102	500	805*740*925
100					290	1500	1.6		319	120	630	1010*760*960
125					340	1800	1.5		362	129	660	1015*710*970
160					400	2200	1.4		420	142	745	1025*720*985
200					480	2600	1.3		473	165	865	1035*720*1065
250					560	3050	1.2		612	185	1030	1075*750*1095
315					670	3650	1.1		696	193	1160	1315*935*1155
400					800	4300	1.0	832	269	1395	1370*920*1170	
500					960	5150	1.0	987	272	1675	1410*1000*1275	
630					1200	6200	0.9	1181	295	2020	1410*970*1340	
800					1400	7500	0.8	1296	410	2380	1580*1070*1355	
1000					1700	10300	0.7	1415	444	2660	1730*1220*1420	
1250					1950	12000	0.6	1672	557	3280	1980*1280*1490	
1600					2400	14500	0.6	2085	649	4040	1920*1355*1585	
2000					2850	19500	0.6	2415	883	4855	1980*1470*1660	
2500					3000	21300	0.6	2975	975	5715	2145*1460*2250	

## S11 Electric Oil Immersed Power Transformer

### Product Description

The S11 series fully sealed oil-immersed power transformer developed and produced by the company has the advantages of low loss, low noise and high efficiency, which can achieve good energy-saving effects and reduce pollution.

The transformer is isolated from the air to prevent and slow down the deterioration of oil and insulation aging so as to enhance operational reliability, and maintain normal operation without maintenance.



## Product Features

- 01 Reduce load loss and no-load current**  
The transformer core is laminated with imported cold-rolled silicon steel sheets, which greatly reduces the no-load loss and no-load current.
- 02 Strong resistance to short circuit**  
High and low voltage windings are made of oxygen-free copper. Low voltage windings of 500kVA and below adopt double-layer cylindrical structure; 630kVA and above adopt double helix or four helix structure, high voltage winding adopts multilayer cylindrical structure; 1000kVA and above adopt foil winding. The product has strong short-circuit resistance.
- 03 power supply quality**  
The transformer connection group uses Dyn11 to reduce the impact of harmonics on the power grid and improve the quality of power supply.
- 04 Long service life**  
The transformer is a fully sealed structure, which prolongs the service life
- 05 Denoise**  
The measured noise value is lower than the standard.
- 06 Reduce installation time**  
The terminal box can be used for oil transformers above 2000kva, which can reduce on-site installation time, improve product's protection level to IP54, and prolong the service life of the protection components.





## Model Implication

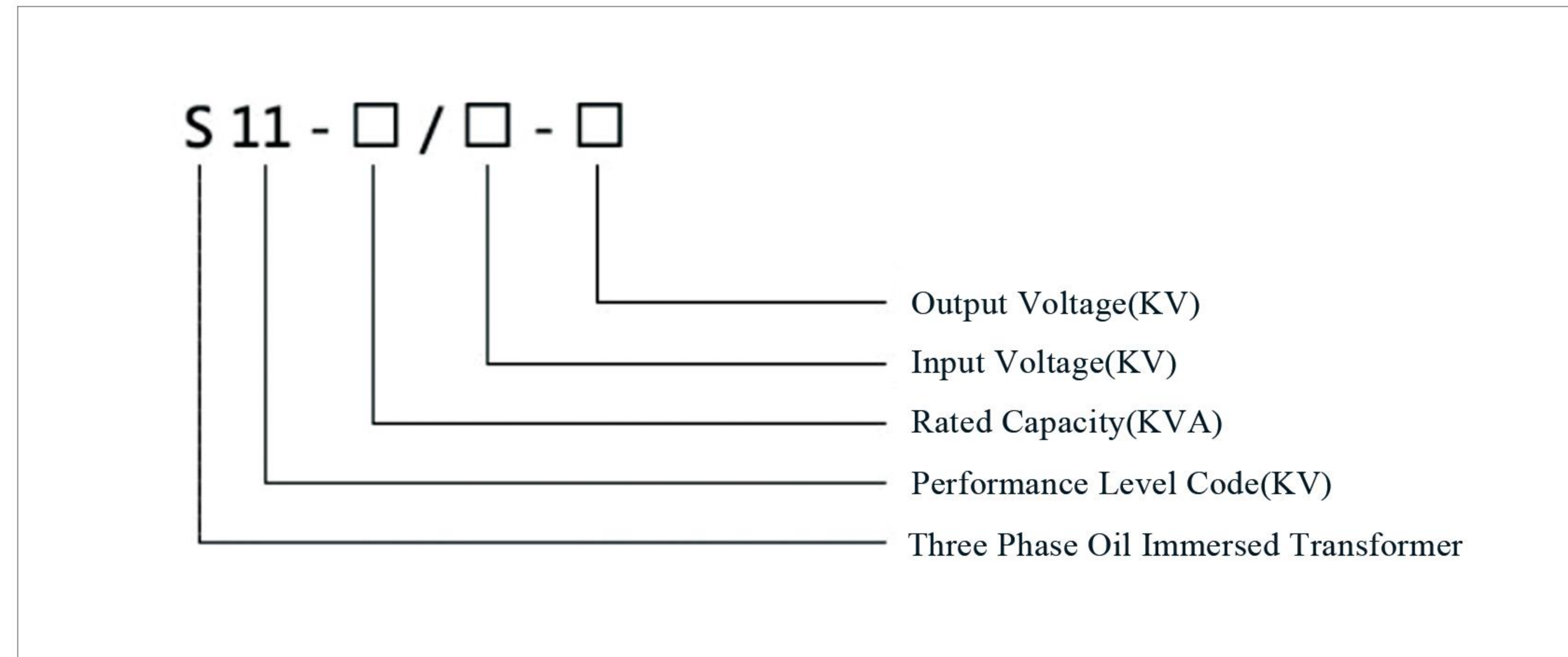

## Product Standard

- + IEC/60076
- + GB/T 1094 Power Transformer
- + GB/T 15164 Oil-immersed Power Transformer Load Guide
- + GB/T 6451 Three-phase Oil-immersed Power Transformer Technical Parameters and Requirements

## Technical Parameter

Technical Parameter for S11 Series 6kv - 11kv No-load Voltage Regulation Transformers													
Rated Capacity (KVA)	Voltage Combination			Connection Group Symbol	No-load Loss (W)	Load Loss (W)	Impedance Voltage(%)	No-load Current (%)	L*W*H(mm)	Gauge Horizontal*Vertical (mm)	Active parts Weight (kg) * Oil Weight (kg)	Total Weight (kg)	
	High Voltage (KV)	Tapping Range of High Voltage	Low Voltage (KV)										
30	6	±5% ±2x2.5%	0.4	Dyn11 Yzn11 Yyn0	100	630/600	4	2.8	980*735*1145	400*400	178*78	355	
50					130	910/870		2.5	1017*758*1205	450*400	240*92	415	
63					150	1090/1040		2.4	1035*785*1285	450*400	285*105	505	
80					180	1310/1250		2.2	1065*800*1290	450*400	330*110	540	
100					200	1580/1500		2.1	1072*820*1305	450*400	345*116	590	
125					240	1890/1800		2	1155*1105*1310	450*400	415*135	705	
160					280	2310/2200		1.9	1235*850*1535	550*550	485*135	835	
200					340	2730/2600		1.8	1282*860*1557	550*550	582*168	965	
250					400	3200/3050		1.7	1310*940*1605	550*550	695*210	1135	
315					480	3830/3650		1.6	1465*1120*1915	660*650	855*255	1520	
400					570	4520/4300		1.5	1440*1165*1725	660*650	950*295	1590	
500					680	5410/5150		1.4	1510*1250*1845	660*650	1150*320	1905	
630					810	6200		1.3	1650*1140*1920	660*650	1500*435	2015	
800					980	7500		4.5	1.2	2125*1175*2315	820*820	1910*760	3510
1000					1150	10300			1.1	2150*1380*2570	820*820	2125*880	3850
1250					1360	12000			1	2355*1485*2570	820*820	2605*960	4610
1600	1640	14500	5	0.9	2335*1750*2630	820*820	3125*1150	5420					
2000	1940	18300		0.4	1940*1400*1700	820*820	2420*780	4200					
2500	2290	21200		0.4	2050*1480*1800	820*820	2560*780	4680					

## Applicable Environment

- + High ambient temperature: +40°C
- + Low ambient temperature: -25°C
- + Altitude: <1000m. We can also customize according to your demand.
- + Monthly average relative humidity: 90% (20°C)
- + Installation location: chemical plants, factories, remote places and harsh environment.

**We can also customize according to your demand.**

Note: Parameter is for reference only, if any changes should follow the factory technical data.

## Technical Parameter

Technical Parameter for S11 Series 20kv No-load Voltage Regulation Transformer							Technical Parameter for S11 Series 35kv No-load Voltage Regulation Transformer												
Rated Capacity (KVA)	Voltage Combination			Connection Group Symbol	No-load Loss (W)	Load Loss (W)	Impedance Voltage(%)	No-load Current (%)	Rated Capacity (KVA)	Voltage Combination			No-load Loss (W)	Load Loss (W)	Impedance Voltage(%)	No-load Current (%)	L*W*H (mm)	Active parts Weight (kg) * Oil Weight (kg)	Total Weight (kg)
	High Voltage (KV)	Tapping Range of High Voltage	Low Voltage (KV)							High Voltage (KV)	Tapping Range of High Voltage	Low Voltage (KV)							
30	20	±5% ±2x2.5%	0.4	Dyn11	90	690/660	5.5	2.1	50	35	±5%	0.4	160	1200/1140	6.5	1.3	1195*935*1825	300*330	860
50					130	1010/960		2	100				230	2010/1910		1.1	1200*995*1935	470*383	1130
63					150	1200/1150		1.9	125				270	2370/2260		1.1	1235*940*1955	550*465	1335
80					180	1440/1370		1.8	160				280	2820/2680		1	1285*895*1950	580*485	1475
100					200	1730/1650		1.6	200				340	3320/3160		1	1310*1150*1985	680*595	1755
125					240	2080/1980		1.5	250				400	3950/3760		0.95	1450*1090*2010	860*650	2000
160					340	3000/2860		1.3	315				480	4750/4530		0.95	1930*1065*2320	980*765	2290
200					400	3520/3350		1.2	400				580	5740/5470		0.85	1850*1165*2015	1170*885	2725
250					480	4210/4010		1.1	500				680	6910/6580		0.85	2045*1205*2415	1340*960	3090
315					570	4970/4730		1	630				830	7860		0.65	2085*1240*2515	1550*895	3810
400					680	5940/5660		1	800				980	9400		0.65	2305*1615*2685	1990*1030	4510
500					810	6820		0.9	1000				1150	11500		0.65	2545*1540*2590	2415*1475	5055
630					980	8250		0.8	1250				1400	13900		0.6	2495*2010*2675	2480*1405	5290
800					1150	11330		0.7	1600				1690	16600		0.6	2680*2100*2770	2600*1490	5450
1000					1380	13200		0.6	2000				1990	19700		0.55	2790*2180*2860	2720*1590	5600
1250	1660	15950	0.6	2500	2360	23200	0.55	2900*2290*2980	2830*1720	5760									
1600	1950	19140	0.6																
2000	2340	22200	0.5																
2500																			

Note: Parameter is for reference only, if any changes should follow the factory technical data.

Technical Parameter for S11 Series 35kv Three-phase Dual-winding No-load Voltage Regulation Transformer

Rated Capacity (KVA)	Voltage Combination			Connection Group Symbol	No-load Loss (W)	Load Loss (W)	No-load Current (%)	Impedance Voltage (%)	L*W*H (mm)	Active parts Weight (kg) * Oil Weight (kg)	Total Weight (kg)	
	High Voltage (KV)	Tapping Range of High Voltage	Low Voltage (KV)									
630	35	±2x2.5% ±5%	3.15	Yd11	830	7860	0.65	6.5	2400*1700*221	2210*900	3250	
800					980	9400	0.65		2500*1850*239	2350*1030	3500	
1000					1150	11500	0.65		2700*1950*251	2490*1180	3860	
1250					1400	13900	0.55		2900*2050*263	2600*1350	4350	
1600					1690	16600	0.45		3050*2130*275	2810*1580	4855	
2000					2170	18300	0.45		3105*2195*280	2800*1800	5300	
2500					2560	19600	0.45		3150*2535*298	3525*2060	7665	
3150					3040	23000	0.45		3920*2725*284	3950*2205	8565	
4000					3610	27300	0.45		7	3310*2915*307	4825*2560	10115
5000					4320	31300	0.45		3480*3020*314	5700*2635	11305	
6300	5240	35000	0.45	3590*2905*321	7120*3240	13510						
8000	7200	38400	0.35	8	4070*3050*359	8875*3840	16690					
10000	8700	45300	0.35	4106*2795*365	10305*3600	17690						
12500	1000	53800	0.3	4570*3010*384	12830*4310	20990						
16000	1210	65800	0.3	5235*3295*461	16010*6650	27660						
20000	1440	79500	0.3	5360*3415*466	18820*7600	32170						
25000	1700	94000	0.25	10	5830*3810*486	22360*9800	42600					
31500	2020	112000	0.25	6290*4290*526	25110*12010	49960						

Note: Parameter is for reference only, if any changes should follow the factory technical data.

## S11-M.ZT On-load Tap Changed (OLTC) Power Transformer with Adjustable Capacity

### Product Description

The S11-M.ZT on-load automatic capacity adjustment and voltage regulation distribution transformer has two types of rated capacity. The automatic capacity adjustment controller automatically detects and judges according to the size of the load carried by the user. Through a special on-load capacity adjustment switch, the two capacities of the transformer can be automatically switched under the state of the transformer without power failure, and the capacity of the transformer can be automatically adjusted during operation, so as to realize the automatic conversion of the two capacity operation modes of the distribution transformer.



### Model Implication

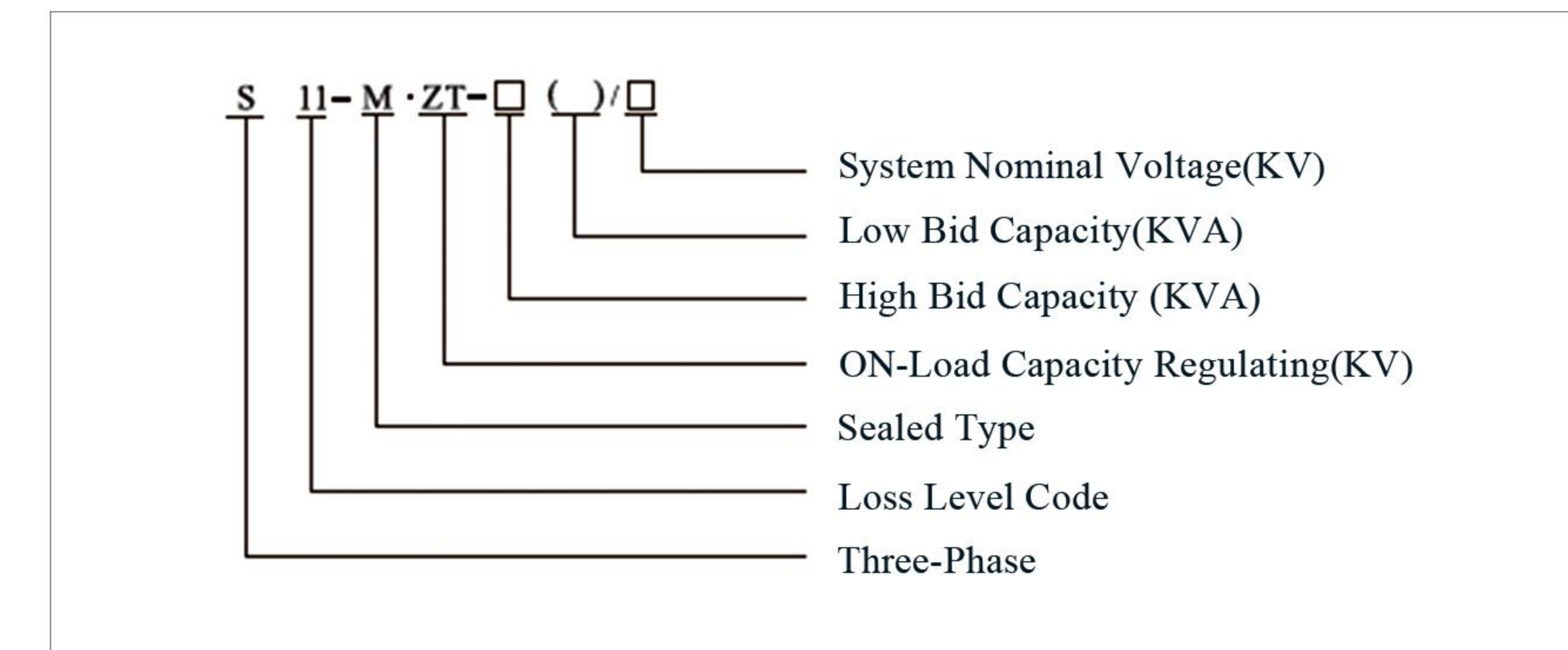

### Product Features

#### Good Performance of Loss Reducing and Energy Saving

+The load factor is elevated from 30~40% up to 70~80%, greatly increasing the transformer's operation efficiency and reducing loss.

+The capacity can be changed in time according to the electrical load. It can effectively reduce the no-load loss while improving the reliability of power supply. According to statistical data, one S11 type large and small capacity regulating transformer of 200kVA and 63kVA can save 4725kWh of electric energy per year compared with the same type of ordinary transformer.

#### Flexible Power Supply Modes, Stable Working and Simple Operation

The two capacity levels can be adjusted with no excitation according to the load status and operation units can be conveniently changed according to the status of load and voltage of the power grid, keeping the transformer operating in an economical status while remaining stable.

## Product Standard

### + IEC/60076

- + GB/T 1094 Power Transformer
- + GB/T 15164 Oil-immersed Power Transformer Load Guide
- + GB/T 6451 Three-phase Oil-immersed Power Transformer Technical Parameters and Requirements

## Applicable Environment

- + High ambient temperature: +40°C
- + Low ambient temperature: -25°C
- + Altitude: <1000m. We can also customize according to your demand.
- + Monthly average relative humidity: 90% (20°C)
- + Installation location: used in chemical plants, factories, remote places and harsh environment.

**We can also customize according to your demand.**

## Technical Parameter

Voltage combination							No-load current (%)	Short -circuit impedance (%)
Rated capacity (kVA)	High Voltage (kV)	HV tapping range (%)	Low-voltage (kv)	Connection Group symbol	No-load loss (W)	Load loss (W)		
160(50)	10 10.5 11	+/-5	0.4	Dyn11 YynO	400(170)	2585(870)	1.6(0.9)	
200(63)					480(200)	3060(1040)	1.5(0.9)	
250(80)					560(250)	3600(1250)	1.4(0.7)	4.0 (4.0)
315(100)					670(290)	4320(1500)	1.4(0.7)	
400(125)					800(340)	5220(1800)	1.3(0.6)	
500(160)					960(400)	6210(2200)	1.2(0.6)	
630(200)					1200(470)	7650(2600)	1.1(0.5)	4.5 (4.0)

## S13 Electric Oil Immersed Power Transformer

### Product Description

The S13 type is developed by our company on the basis of S11 distribution transformers through the research and application of new materials and new processes, and the combination of independent innovation and technology introduction. Through the optimized and innovative design of the core and coil structure, the goal of reducing no-load loss and noise is achieved. Compared with the current national standard JB/T10088-2004, the noise level has dropped by an average of 20%.



### Product Features

- 01 The transformer core is laminated with imported cold-rolled silicon steel sheets, which greatly reduces the no-load loss and no-load current.
- 02 High and low voltage windings are made of oxygen-free copper, and low voltage windings adopt double-layer cylindrical structure. high voltage winding adopts multilayer cylindrical structure. 1000kVA and above can adopt foil winding. The product has strong short-circuit resistance.
- 03 The transformer connection group uses Dyn11 to reduce the impact of harmonics on the power grid and improve the quality of power supply.
- 04 The transformer is a fully sealed structure, which prolongs the service life
- 05 The measured noise value is lower than the standard.



## Model Implication

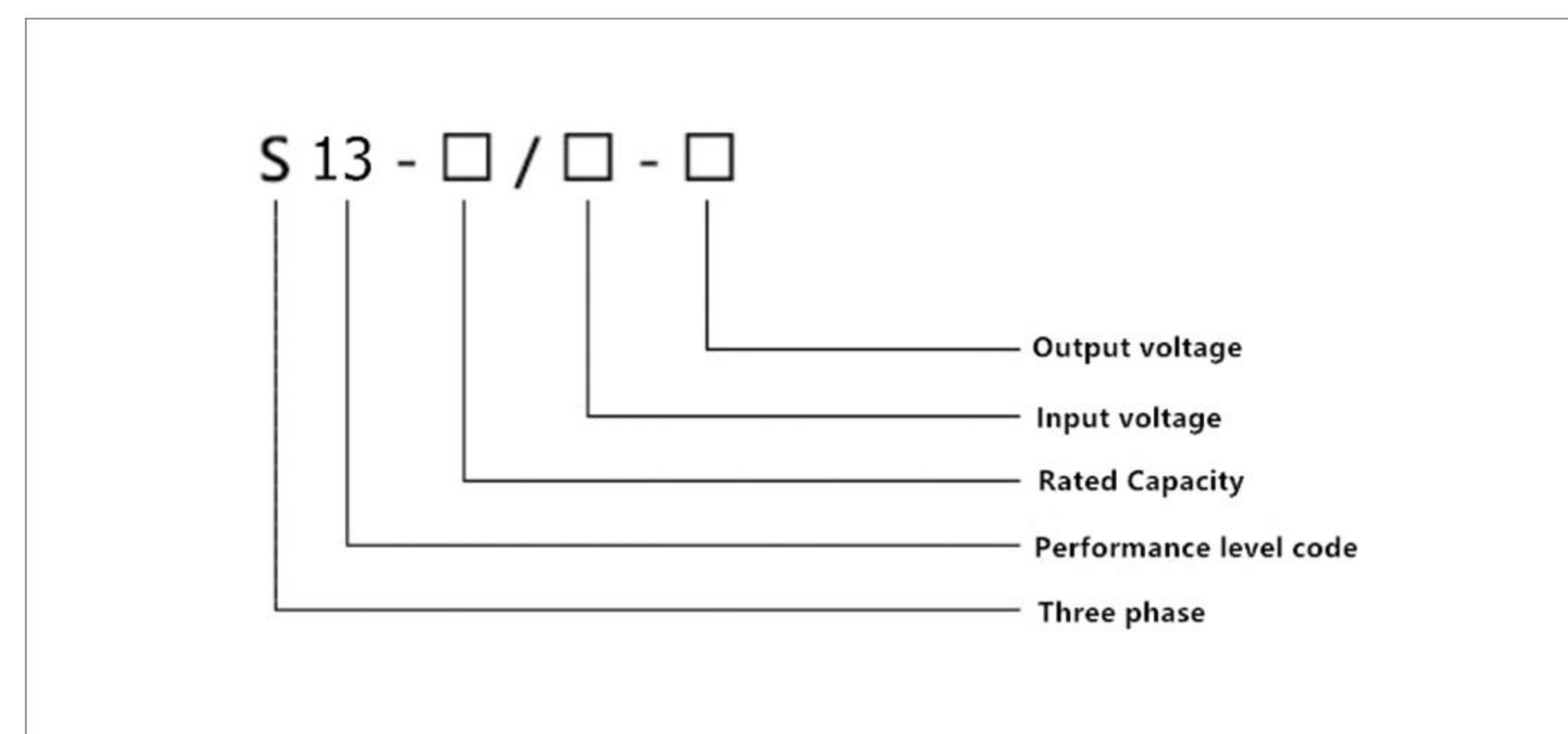

## Product Standard

### + IEC/60076

- + GB/T 1094 Power Transformer
- + GB/T 15164 Oil-immersed Power Transformer Load Guide
- + GB/T 6451 Three-phase Oil-immersed Power Transformer Technical Parameters and Requirements

## Environmental conditions

- + The altitude does not exceed 1000m.
- + Maximum temperature: +40°C
- + Average temperature of the hottest month: +30°C
- + Minimum temperature: -10°C (outdoor)
- + Maximum daily temperature difference: 25K
- + Ice thickness: 10mm
- + Monthly average maximum relative humidity (25°C): 90%
- + Installation location: outdoor

We can also customize according to your demand.



Strategic Layout



Teamwork



Enterprise Service

## Technical Parameter

Model	Rated Capacity (KVA)	Connection group label	Voltage combination (KV)			No-load loss	Load loss		No-load current(%)	Short circuit resistance (%)	Weight (kg)
			High voltage	Tap range	Low voltage		Dy	Yy			
S13-M-10	10	Yyn0 or Dyn11	10 6.3 6	±5% ±2X2.5% or +3X2.5% -1X2.5%	0.4	40	360	340	2.8	4.0	
S13-M-20	20					70	525	500	2.5		
S13-M-30	30					80	630	600	2.3		
S13-M-50	50					100	910	870	2.0		
S13-M-63	63					110	1090	1040	1.9		
S13-M-80	80					130	1310	1250	1.9		
S13-M-100	100					150	1580	1500	1.8		
S13-M-125	125					170	1890	1800	1.7		
S13-M-160	160					200	2310	2200	1.6		
S13-M-200	200					240	2730	2600	1.5		
S13-M-250	250					290	3200	3050	1.4		
S13-M-315	315					340	3830	3650	1.4		
S13-M-400	400					410	4520	4300	1.3		
S13-M-500	500					480	5410	5150	1.2		
S13-M-630	630					570	6200	6200	1.1		
S13-M-800	800					700	7500	7500	1.0		
S13-M-1000	1000					830	10300	10300	1.0		
S13-M-1250	1250					970	12000	12000	0.9		
S13-M-1600	1600					1170	14500	14500	0.8		
S13-M-2000	2000					1510	17800	17800	0.8		
S13-M-2500	2500	1780	20700	20700	0.7	5.0					
S13-M-3150	3150	2100	24300	24300	0.7						

## S13-MRL Series Three-dimensional Wound Core Power Transformer

### Product Description

+The three-dimensional wound core transformer is an energy-saving power transformer. It is a distribution transformer with a triangular three-dimensional arrangement of iron cores assembled by three single-frame wound cores of the same geometric size, and the three-dimensional wound core as the magnetic circuit.

+The power saving effect of three-dimensional wound core transformer is significant, the noise is greatly reduced, heat dissipation and overload stronger capacity, compact structure and small size.



## Product Features

- 01

**Low loss**

According to the current international GB/T6451-2015, the no-load loss of S13-M.RL series is reduced by an average of 50%, and the load loss is reduced by an average of 30%.
- 02

**Low no-load current**

Due to the excellent material of the wound core and the characteristics of winding processing, the no-load current is significantly reduced. According to the current national GB/T6451-1999, S13-M.RL series no-load current drops by an average of 75%.
- 03

**Low operating noise**

According to JB/T10088-1999 noise standard, the noise of S13-M.RL and S11-M.RL series are reduced by about 7-9dB.
- 04

**Strong short circuit resistance**

The transformer body is in the shape of a three-dimensional triangular prism. which can effectively resist the axial and radial mechanical stress during sudden short circuit.

## Model Implication

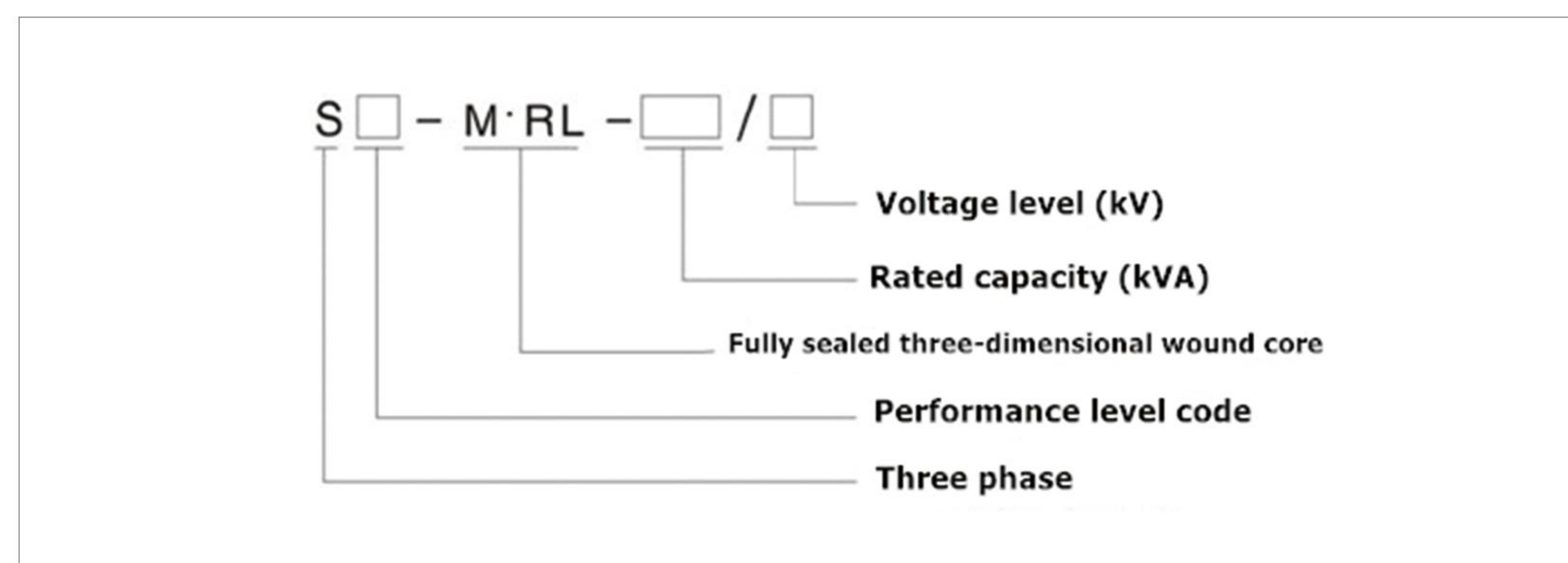

## Product Standard

- + IEC/60076
- + GB/T 1094 Power Transformer
- + GB/T 15164 Oil-immersed Power Transformer Load Guide
- + GB/T 6451 Three-phase Oil-immersed Power Transformer Technical Parameters and Requirements

## Environmental conditionst

- + High ambient temperature: +40°C
- + Low ambient temperature: -25°C
- + Altitude: <1000m. We can also customize according to your demand.
- + Monthly average relative humidity: 90% (25°C)
- + Installation location: chemical plants, factories, remote places and harsh environment.

**We can also customize according to your demand.**

## Technical Parameter

S13-M.RL Series Three-dimensional Wound Core Power Transformer										
Model	Rated Capacity (KVA)	Connection Group Symbol	Voltage Combination			No-load Loss R(W)	Load Loss R(W)	No-load Current (%)	Impedance Voltage(%)	Total Weight (kg)
			High Voltage (KV)	Tapping Range of High Voltage	Low Voltage (KV)					
S13-M.RL	30	Dyn11 Yzn11 Yyn0	6 6.3 10 10.5 11	±5% ±2x2.5%	0.4	80	600	0.30	4.0	280
S13-M.RL	50					100	870	0.24		390
S13-M.RL	63					110	1040	0.23		440
S13-M.RL	80					130	1250	0.22		495
S13-M.RL	100					150	1500	0.21		600
S13-M.RL	125					170	1800	0.20		690
S13-M.RL	160					200	2200	0.19		780
S13-M.RL	200					240	2600	0.18		908
S13-M.RL	250					290	3050	0.17		1043
S13-M.RL	315					340	3650	0.16		1190
S13-M.RL	400					410	4300	0.16		1430
S13-M.RL	500					480	5150	0.16		1648
S13-M.RL	630					570	6200	0.15		2027
S13-M.RL	800					700	7500	0.15		2316
S13-M.RL	1000	830	10300	0.14	2600					
S13-M.RL	1250	970	12000	0.13	2890					
S13-M.RL	1600	1170	14500	0.12	3380					
S13-M.RL	2000	1360	14530	0.12	3600					
S13-M.RL	2500	1500	17270	0.11	3890					
S13-M.RL		Yyn0 or Dyn11							4.5	





# DRY TYPE TRANSFORMERS

## Dry Type Transformers SCB10 / SCB11/ SCB13

Dry type transformers refer to transformers in which the core and windings are not immersed in insulating oil. The cooling methods are divided into natural air cooling (AN) and forced air cooling (AF). When natural air cooling, the transformer can run continuously for a long time under the rated capacity. When forced air cooling, the output capacity of the transformer can be increased by 50%. It is suitable for intermittent overload operation or emergency accident overload operation. Dry-type transformer is one of the important equipment in the power supply and distribution system of industrial and mining enterprises and civil buildings. It reduces the 10(6)kV or 35kV network voltage to the 230/400V bus voltage used by the user.



## Application Channels

Especially suitable for important places such as urban power grids, high-rise buildings, business centers, theaters, hospitals, hotels, tunnels, subways, underground power stations, stations, docks, airports, combined substations, etc.

## Product Features

Since epoxy resin is a non-flammable, flame-retardant, self-extinguishing solid insulating material, safe and clean, epoxy resin cast dry-type transformers are oil-free, non-flammable, and have low operating loss, strong short-circuit resistance, less maintenance work, high working efficiency, small volume and low noise.

It is often used in places with high performance requirements such as fire prevention and explosion protection, and has the following practical characteristics:

- 01 It is safe, fireproof, pollution-free, and can be directly operated in the load center;
- 02 High mechanical strength, strong short-circuit resistance, small partial discharge, good thermal stability, high reliability and long service life;
- 03 Low loss, low noise, obvious energy saving effect, maintenance-free;
- 04 Good heat dissipation performance, strong overload capacity, and capacity operation can be increased when forced air cooling;
- 05 Good moisture resistance, adapt to high humidity and other harsh environments;
- 06 Dry-type transformers Using intelligent signal temperature control system, it can automatically detect and display the respective operating temperatures of the three-phase windings, can automatically start and stop the fan, and have functions such as alarms and trips;
- 07 Small size, light weight, less space and low installation cost.

## Product Features

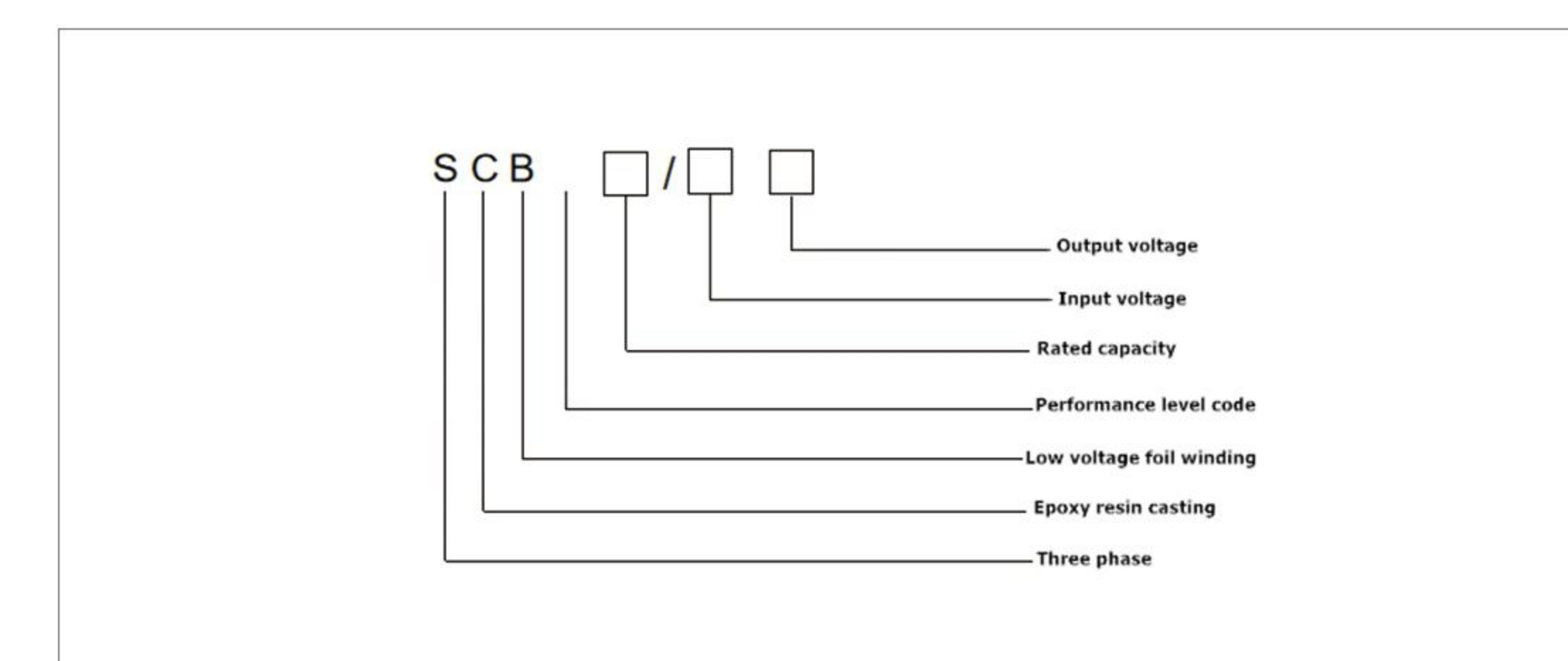

## Applicable Environment

+ 0-40 (°C), relative humidity <70%;

+ Altitude: no more than 2500 meters;

**We can also customize according to your demand.**

## Technical Parameter

Main performance parameters for SC (B) 10 11KV voltage regulating power transformer without excitation									
Model	Rated capacity (KVA)	Connection symbol	Voltage combination (KV)			No-load loss (W)	Load loss (W)	No-load current (%)	Short circuit impedance (%)
			High-voltage	Tapping range	Low-voltage				
SC10-30	30	Yyn0 or Dyn11	11 10.5 10 6.3 6	±5% ±2×2.5%	0.4	190	710	2.4	4
SC10-50	50					270	1000	2.4	
SC10-80	80					370	1380	1.8	
SC10-100	100					400	1570	1.8	
SC10-125	125					470	1850	1.6	
SCB10-160	160					550	2130	1.6	
SCB10-200	200					630	2530	1.4	
SCB10-250	250					720	2760	1.4	
SCB10-315	315					880	3470	1.2	
SCB10-400	400					980	3990	1.2	
SCB10-500	500					1160	4880	1.2	
SCB10-630	630					1350	5880	1	
SCB10-630	630					1300	5960	1	
SCB10-800	800					1520	6960	1	
SCB10-1000	1000					1770	8130	1	
SCB10-1250	1250					2090	9690	1	
SCB10-1600	1600					2450	11730	1	
SCB10-2000	2000					3050	14450	0.8	
SCB10-2500	2500					3600	17170	0.8	
SCB10-1600	1600					2450	12900	1	
SCB10-2000	2000	3050	15890	0.8					
SCB10-2500	2500	3600	18890	0.8					

Main performance parameters for SC (B) 10 15-22KV voltage regulating power transformer without excitation									
Model	Rated capacity (KVA)	Connection symbol	Voltage combination (KV)			No-load loss (W)	Load loss (W)	No-load current (%)	Short circuit impedance (%)
			High-voltage	Tapping range	Low-voltage				
SC10-50	50	Yyn0 or Dyn11	15 20 22	±5% ±2×2.5%	0.4	345	1180	2.4	6
SC10-100	100					545	1910	2.2	
SC10-160	160					682	2780	1.8	
SC10-200	200					745	2820	1.8	
SC10-250	250					855	3280	1.6	
SC10-315	315					980	3910	1.6	
SC10-400	400					1165	4640	1.4	
SC10-500	500					1365	5550	1.4	
SC10-630	630					1545	6550	1.2	
SC10-800	800					1775	7910	1.2	
SC10-1000	1000					2090	9370	1	
SC10-1250	1250					2410	11050	1	
SC10-1600	1600					2820	13300	1	
SC10-2000	2000					3280	15690	0.8	
SC10-2500	2500					3910	18550	0.8	

Main performance parameters for SC (B) 10 35KV voltage regulating power transformer without excitation									
Model	Connection symbol	Voltage combination (KV)			No-load loss (W)	Load loss (W)	No-load current (%)	Short circuit impedance (%)	
		High-voltage	Tapping range	Low-voltage					
SC10-800	Dyn11 Yd11 Yyn0	33-38.5	±5% ±2×2.5%	3.5	2200	9400	1.1	6	
SC10-1000				6	2610	10800	1.1		
SC10-1250				6.3	3060	11900	1		
SC10-1500	10			3600	15400	1	7		
SC10-2000	10.5			4130	18200	0.9			
SC10-2500	11			4750	21800	0.9	8		
SC10-3150	5880			24500	0.8				
SC10-4000	6860			29400	0.8				
SC10-5000	8180			34960	0.7				
SC10-6300	9680			40800	0.7	9			
SC10-8000	11000	46060	0.6						
SC10-10000	12660	56500	0.6						
SC10-12500	15400	64600	0.5						
SC10-16000	18900	76000	0.5						
SC10-20000	22400	85500	0.4	10					

## SG (B) 10 Series Non-encapsulated Dry-type Power Transformers

SG (B) 10 series of non-encapsulated dry-type power transformers adopt the special process technology of Europe dry-type transformers to ensure that the products fully meet the requirements such as fire prevention, waterproof, environmental protection.

By optimizing the structure of the high-voltage coil, the series improve the distribution of voltage and capacitance between layers so as to improve the product's ability to withstand atmospheric overvoltage, operating overvoltage as well as the electric field distribution.

It is the ideal product for distribution systems and widely used in the subway, shipbuilding, mining, chemical, power companies and personnel-intensive buildings as well as other special requirements of the occasion for safety.



## Application Channels

The transformer can replace oil-immersed distribution transformers. It is a superior product in all types of dry-type transformers. It is especially suitable for urban power grids, high buildings, business centers, hospitals, combined substations, etc.

## Product Features

- 01

### H-Grade Insulation

SG10 Series power transformers use great material and new technology to achieve H-grade insulation, it is reliably used in ambient temperature up to 180°C and the main part of the transformer can sustain up to 220°C.
- 02

### Safety

SG10 series power transformers use insulated materials which is flame retardant and moisture-proof, the combustible material is only 10% of the epoxy resin transformer. There's no poisonous fumes during long time burning at 800°C.
- 03

### Reliable

SG10 series power transformers use special coil design and technology to achieve moisture-proof, mould proof and fame proof. It can sustain high thermal shock without partial discharge.
- 04

### Strong over-load ability

SG10 series power transformer can sustain 120% rated capacity. It can longtime running under IP23 without force air cooling.

## Model Implication

Product Model No.	Connection Group Symbol	Loss W		Impedance Voltage (%)	No-load Current (%)	Overall Dimension (without enclosure) mm						Weight (Kg)	
		No-load Loss R	145°C Load Loss R (W)			L	W	H	L1	L2	d		f
SG10-30/10	Y yn0 D yn11	190	760	4	2	900	1180	880	265	220	550	550	420
SG10-50/10		270	1070		2	940	1180	985	295	220	550	550	450
SG10-80/10		370	1480		1.5	985	1180	1055	295	226	550	660	740
SG10-100/10		400	1690		1.5	1010	1180	1135	295	226	660	660	770
SG10-125/10		470	1980		1.3	1060	1180	1175	306	228	660	820	1005
SG10-160/10		540	2280		1.3	1120	1180	1230	312	228	660	820	1015
SG10-200/10		620	2710		1.1	1180	1230	1275	312	238	660	820	1035
SG10-250/10		720	2960		1.1	1290	1230	1330	315	238	660	820	1155
SG10-315/10		880	3730		1	1320	1340	1355	315	240	820	1070	1365
SGB10-400/10		980	4280		1	1350	1340	1435	315	240	820	1070	1585
SGB10-500/10		1160	5230	1	1395	1340	1495	325	258	820	1070	1795	
SGB10-630/10		1345	6290	0.85	1450	1340	1550	325	268	820	1070	2265	
SGB10-630/10		1300	6400	0.85	1545	1340	1445	325	268	820	1070	1930	
SGB10-800/10		1520	7460	0.85	1590	1340	1490	330	273	820	1070	2450	
SGB10-1000/10		1770	8760	0.85	1680	1340	1555	330	276	820	1070	2640	
SGB10-1250/10		2090	10300	0.85	1710	1470	1635	335	286	820	1070	3170	
SGB10-1600/10		2450	12500	6	0.85	1800	1470	1770	350	330	1070	1070	3985
SGB10-2000/10		3050	15500		0.7	1850	1470	1890	350	346	1070	1070	4850
SGB10-2500/10		3600	18400		0.7	1900	1470	2030	365	356	1070	1070	5620



# TRANSFORMER SUBSTATION

Box-type substation is also called prefabricated substation. It combines high-voltage switchgear, distribution transformers and low-voltage power distribution devices into a single factory prefabricated indoor and outdoor compact power distribution equipment according to a certain wiring scheme, which organically combines functions such as transformer step-down and low-voltage power distribution. Installed in a moisture-proof, rust-proof, dust-proof, rat-proof, fire-proof, anti-theft, heat-insulation, fully-enclosed, and movable steel structure box. Box-type substations are divided into European-style box-type substations, American-type box-type substations, and underground box-type substations.

## YB Preinstalled Type Transformer Substation (European Style)

European-style box-type substation is also called outdoor complete substation or combined substation. Because it has the advantages of flexible combination, convenient transportation, migration, convenient installation, short construction period, low operating cost, small floor space, pollution-free, and maintenance-free, it has received extensive attention. In rural power grid construction (reconstruction), it is widely used in the construction and transformation of 10-110kV small and medium-sized substations (distribution) substations, factories and mines, and mobile operations in urban and rural areas. Because it is easy to penetrate into the load center, reduce the power supply radius, and improve the quality of the terminal voltage, it is especially suitable for the transformation of rural power grids.





## Product Features

**01 Advanced technology, safe and reliable**  
 The outer shell is generally made of galvanized steel plate. The frame adopts standard container materials and manufacturing techniques. It has good anti-corrosion performance and guarantees no corrosion for 20 years. and can ensure normal operation in the harsh environment of -40℃~+40℃.

**02 High degree of automation**  
 The protection system adopts the integrated automatic device of the substation and is installed in a decentralized manner. remote setting of operating parameters, control of humidity and temperature in the box, to meet the requirements of unattended.

**03 Factory prefabrication**  
 All equipment is installed and qualified in the factory at one time. The entire substation takes about 5-8 days from installation to commissioning. Greatly shorten the construction period.

**04 Flexible combination**  
 Due to the compact structure of the European-style box change, each box constitutes an independent system, which makes the combination flexible and changeable.

**05 Low investment and quick results**  
 European-style box substation (35kV equipment outdoor layout, 10kV equipment box installation), compared with the same scale integrated substation (35kV equipment outdoor layout, 10kV equipment layout indoor high-voltage switch room and central control room), reduces investment by 40%-50%.

**06 Cover small space**  
 The minimum area of the main transformer box and the switch box can be as small as 100m. It can be installed and put into production by making full use of the center of the street, the square and the corner of the factory, which is in line with the national land saving policy.

**07 Beautiful appearance**  
 The box shell adopts aluminum-zinc steel plate and container manufacturing technology. The appearance design is beautiful. Under the premise of ensuring the reliability of power supply, by choosing the shell color of the box-type substation, It is especially suitable for urban construction.

## Model Implication

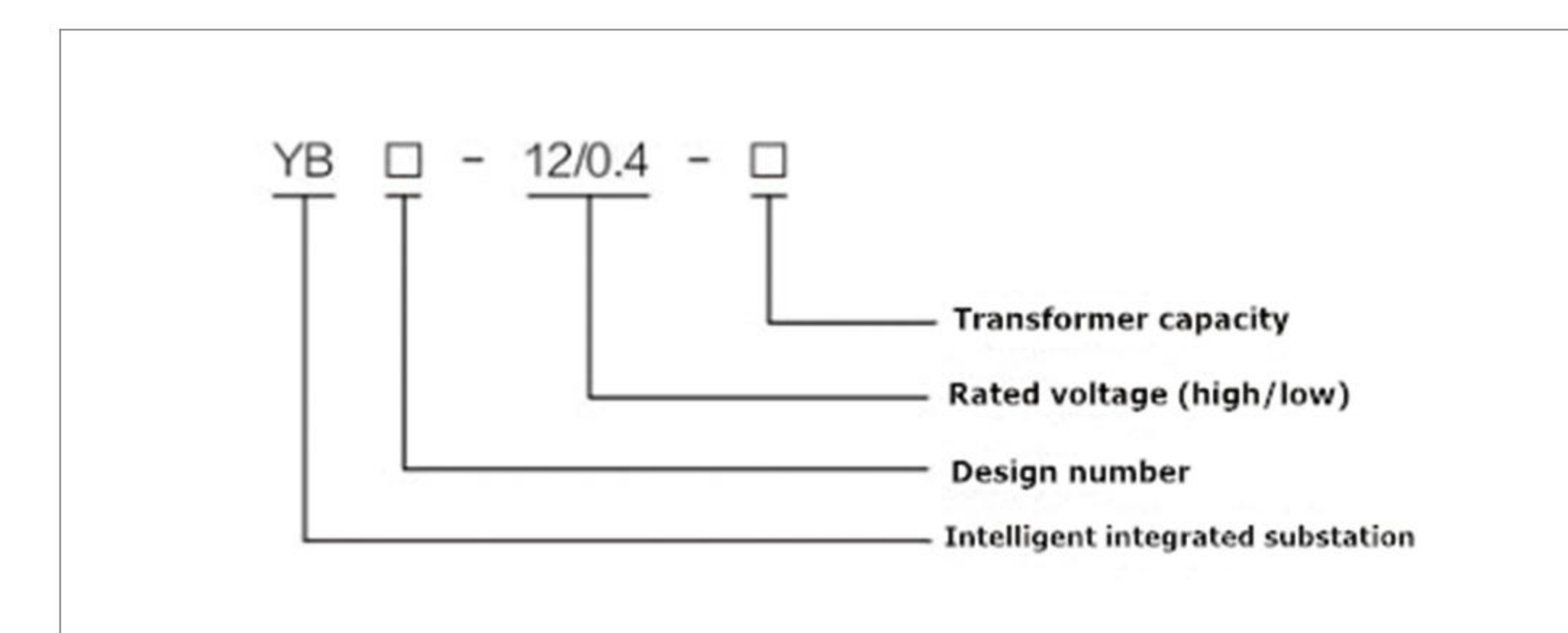

## Technical Parameter

No.	Items	Unit	Value	
1	Rated voltage	Primary	40.5	
		Secondary	kV 12; 0.69	
		Subsidiary circuit	V 110; 220; 380	
2	Rated current	High voltage circuit	400~1250	
		Low voltage circuit	A 630~3150	
3	Rated frequency	Hz	50	
4	Rated power	kVA	1250; 1600; 2000~20000	
5	Rated insulation level	High voltage side	Power frequency	95
			impact	185
		Low voltage side	Power frequency	42
			impact	kV 75
6	Rated short time withstand current	High voltage side	20; 25; 31.5	
		Low voltage side	25; 31.5; 40	
7	Rated peak withstand current	High voltage side	50; 63; 80	
		Low voltage side	kA 63; 80; 100	
8	Insulation level of transformer	Power frequency	65	
		Impact	185	
9	Insulation level of subsidiary circuit	kV	2	



## ZGS Three-Phase Pad-Mountde -Compartmental Type Transformer

+ ZGS Three-Phase Pad-Mountde -Compartmental Type Transformer puts the transformer body, high voltage load switch, fuse and other components together in the transformer tank. Because of the immersion in oil, the volume of the components is greatly reduced, the structure is more compact, and the installation is convenient and flexible.

+ Fully insulated, fully sealed structure, safe and reliable, easy to operate, and maintenance-free.

+ It is widely used in residential quarters, commercial centers, factories and mining enterprises, airports, stations, schools and other places.



### Product Features

- 01 Compact structure, small size, convenient and flexible installation;
- 02 Fully insulated, fully sealed structure, safe and reliable, maintenance-free, reliable protection of personal safety;
- 03 The high-voltage side adopts double fuse protection, in which the plug-in fuse is a dual sensitive fuse (temperature, current), and the backup fuse is a current-limiting fuse, which reduces the operating cost;
- 04 The high-voltage incoming line adopts a cable connector structure, which is fully insulated, safe and reliable, and easy to operate;
- 05 It can be used for both ring network and terminal. The conversion is very convenient and the reliability of power supply is improved.
- 06 The transformer has a three-phase three-column or three-phase five-column structure, and the iron core adopts a stepped joint process or a rolled iron core process, which has low noise, low loss, and strong resistance to short circuits and overloads.
- 07 The cabinet can adopt anti-corrosion design and special painting treatment according to the requirements of the operating environment. It has the "three-proof" function, that is, anti-condensation, anti-salt spray and anti-mold functions, and can meet the anti-corrosion under high temperature and high humidity environment.

## Transformer

Low-loss, oil-immersed, fully sealed S9, S10, and S11 series transformers

### Technical Parameter

ZGS Three-Phase Pad-Mountde -Compartmental Type Transformer													
Loss (W)						Weight (Kg)			(MM)				
Rated Capacity (kVA)	Voltage Group (KV)		Vector Group	-75		No-load current %	Impedance %	Machine	Oil	Gross	(L) (W) (H)		
	HV	LV		No-load	Load						Dimension		
200	10	0.4	Yyn0 or Dyn11	335	2600	0.6	4 4.5	601	733	1894	1865	1240	1735
250				390	3050	0.5		716	749	2060	1865	1280	1735
315				465	3650	0.45		835	733	2148	1865	1730	1735
400				560	4300	0.4		1006	729	2375	1865	1440	1805
500				670	5100	0.4		1156	747	2603	1865	1450	1805
630				840	6200	0.4		1295	757	2826	1865	1450	1805
800				980	7500	0.4		1521	872	3357	1450	1495	1805
1000				1190	10300	0.3		1634	970	3704	1865	1510	1805

## YB MV/LV Prefabricated Substation

MV/LV Prefabricated Substation is mainly composed of buried transformer and outdoor switchgear of advertising light box. The buried transformer is a new type of compact substation equipment composed of a transformer, a high-voltage load switch, a fuse, etc., which is installed in a pit, does not occupy the surface space, and can be submerged in water for a period of time. The outdoor switchgear of advertising light box is a hybrid structure integrating billboards and outdoor switchgear, and is installed on the ground. The inside of the box is an outdoor high and low voltage power distribution cabinet, and both sides are advertising light boxes, which have excellent visual effects. The fully buried type is also called an underground substation. Its box has excellent anti-corrosion and compression resistance, and has absolute air tightness.

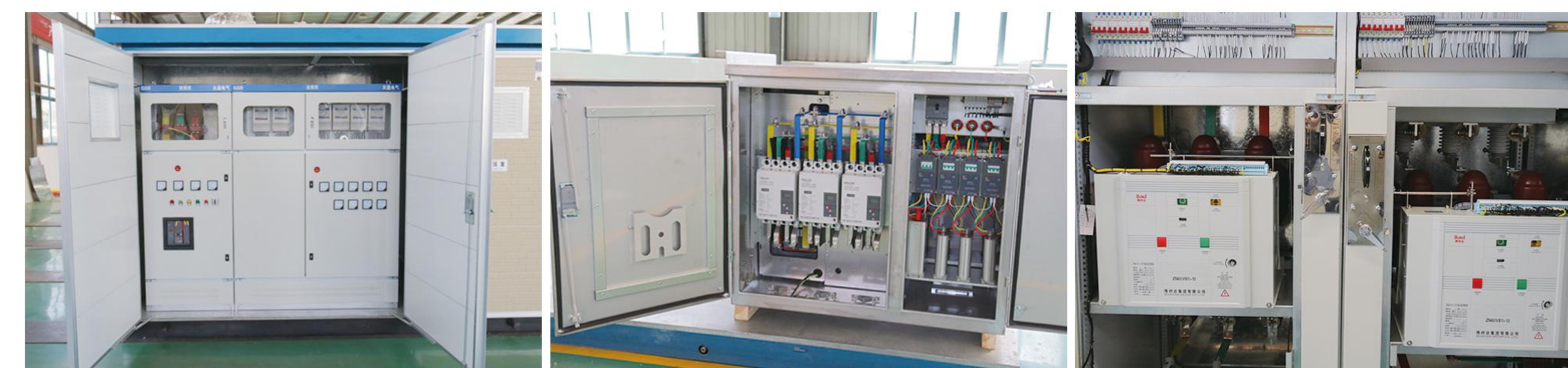

## Product Features

- 01 It can greatly save land, without land acquisition and civil construction, and save infrastructure investment.

---

- 02 There are no obstacles on the ground, which does not affect the environment, and does not affect people's vision and scenery.

---

- 03 The fully buried type installed on the lawn and green belt can also be designed with some decorative ornaments on the ground, such as sculptures, rockery, etc.; if the ground requires no obstacles (including ventilation ducts), you can choose a square type prefabricated substation.

---

- 04 The power distribution equipment of the fully buried prefabricated substation is set underground, which is safe and reliable.

---

- 05 The ground is not affected by transformer noise.

---

- 06 As the underground is relatively shady and cool, the temperature rise of the transformer is relatively stable during operation.

---

- 07 The internal space of the fully buried prefabricated substation is relatively spacious, and the maintenance operation will not cause interference on the ground, and will not interfere with the surrounding environment.

## Product Standard

- + GB10941.2-1996 "Power Transformer"
- + GB109435-2003 "Power Transformer"
- + GB/T6451-1999 "Three-phase Oil-immersed Transformer Technical Parameters and Requirements"
- + GB/T15164-1994 "Guidelines for the Load of Oil-immersed Power Transformers"
- + JB/T10544-2006 "Underground Transformer"
- + GB/T15164-1994 "Guidelines for the Load of Oil-immersed Power Transformers"
- + JB/T10544-2006 "Underground Transformer" B Insulation Level
- + L175AC35/AC59 Protection Class: IP68

## Technical Parameter

Rated voltage	HV: 6/10kV, LV: 0.4kV
Capacity range	30, 50, 63, 80, 100, 125, 160, 200, 250, 315, 400, 500, 630, 800, 1000, 1250, 1600,
Frequency	50Hz
Phase	Single-phase and 3-phase
Vector group	Dyn11, Yyn0
Impedance voltage	According to national standards operation environment
The cellar loss	Reaching national standards operation environment

Rated Capacity KVA	No-load Loss W	On-load Loss (75°) W <sup>o</sup>	No-load Current%	Short Circuit Impedance%	Rated Capacity KVA	No-load Loss W	On-load Loss (75°) W <sup>o</sup>	No-load Current%	Short-circuit Impedance%
30	91	600	0.63	4	400	560	4300	0.3	4.5
50	119	870	0.6		500	672	5100	0.3	
63	140	1040	0.57		630	810	6200	0.27	
80	168	1250	0.54		800	980	7500	0.24	
100	203	1500	0.48		1000	1150	10300	0.21	
125	238	1800	0.45		1250	1360	12000	0.18	
160	280	2200	0.42		1600	1640	14500	0.18	



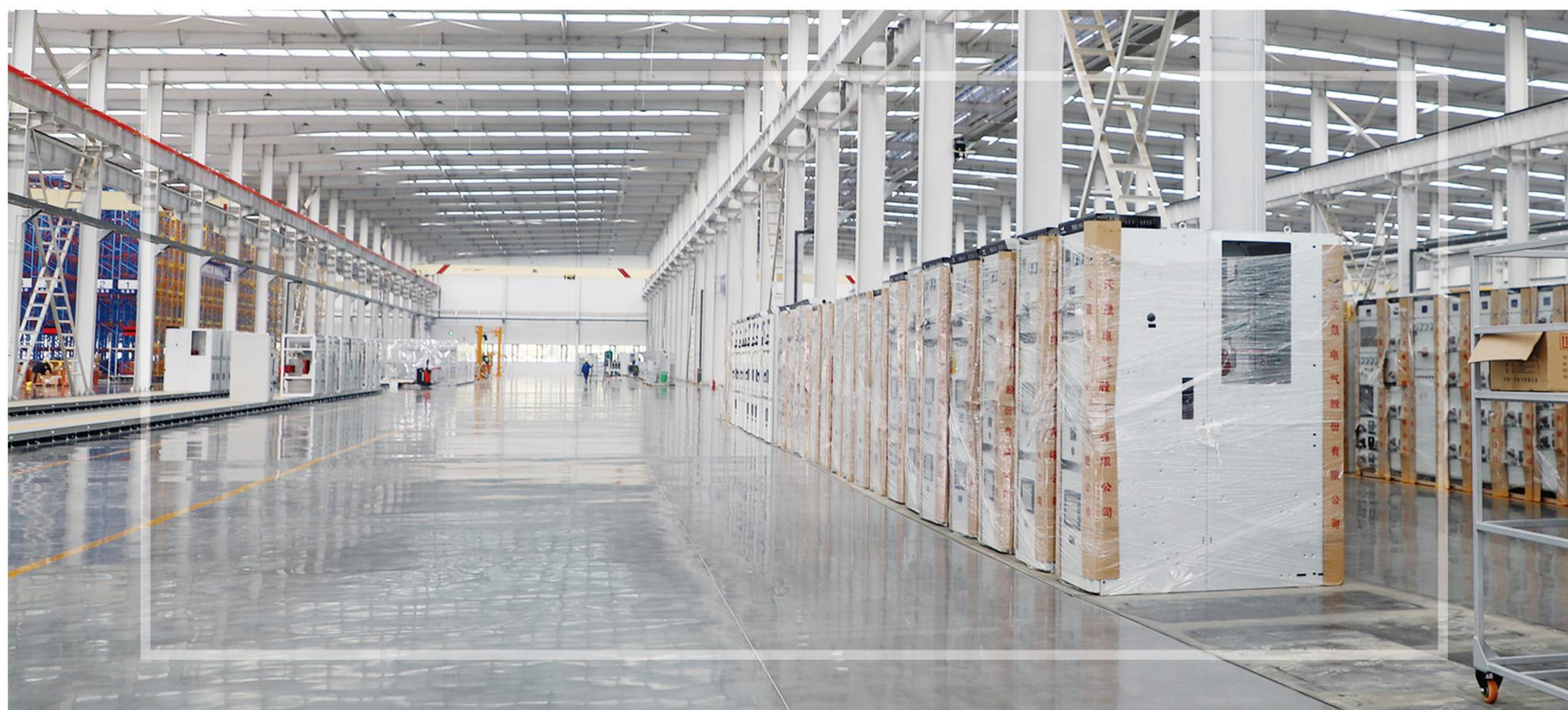

# HIGH AND LOW VOLTAGE SWITCHGEARS

## GCS Low-Voltage Switchgear Panel, Withdrawable Type

GCS Low-Voltage Switchgear Panel, Withdrawable Type also called low-voltage drawer cabinet, has high technical performance indicators, and can adapt to electricity market development. Our low-voltage withdrawable switchgear can compete with the existing imported products and has been widely used by power users.



### Product Features

- 01 Increase the heat capacity of the adapter, and greatly reduce the additional temperature rise caused by the temperature rise of the adapter to the connector, cable head, and spacer plate.
- 02 The separation between functional units and compartments is clear and reliable, and the failure of one unit does not affect the work of other units, so that the failure is limited to a minimum.
- 03 The horizontal arrangement of the busbar makes the device have good dynamic and thermal stability, and can withstand the impact of 80/176kA short-circuit current.

- 04 The number of circuits in a single MCC cabinet is as many as 22, and the needs of large single-unit power generation, petrochemical systems and other industries for automated electric door (machine) groups are fully considered.
- 05 The connection between the device and the external cable is completed in the cable compartment, and the cables can be entered and exited up and down. The zero sequence current transformer is placed in the cable compartment, making installation and maintenance easy.
- 06 The fully s6.The drawer unit has a sufficient number of secondary plug-ins (32 pairs for 1 unit and above, 20 pairs for 1/2 unit). It can meet the requirements of the number of connection points of the computer interface and the automatic control loop.

### Model Implication

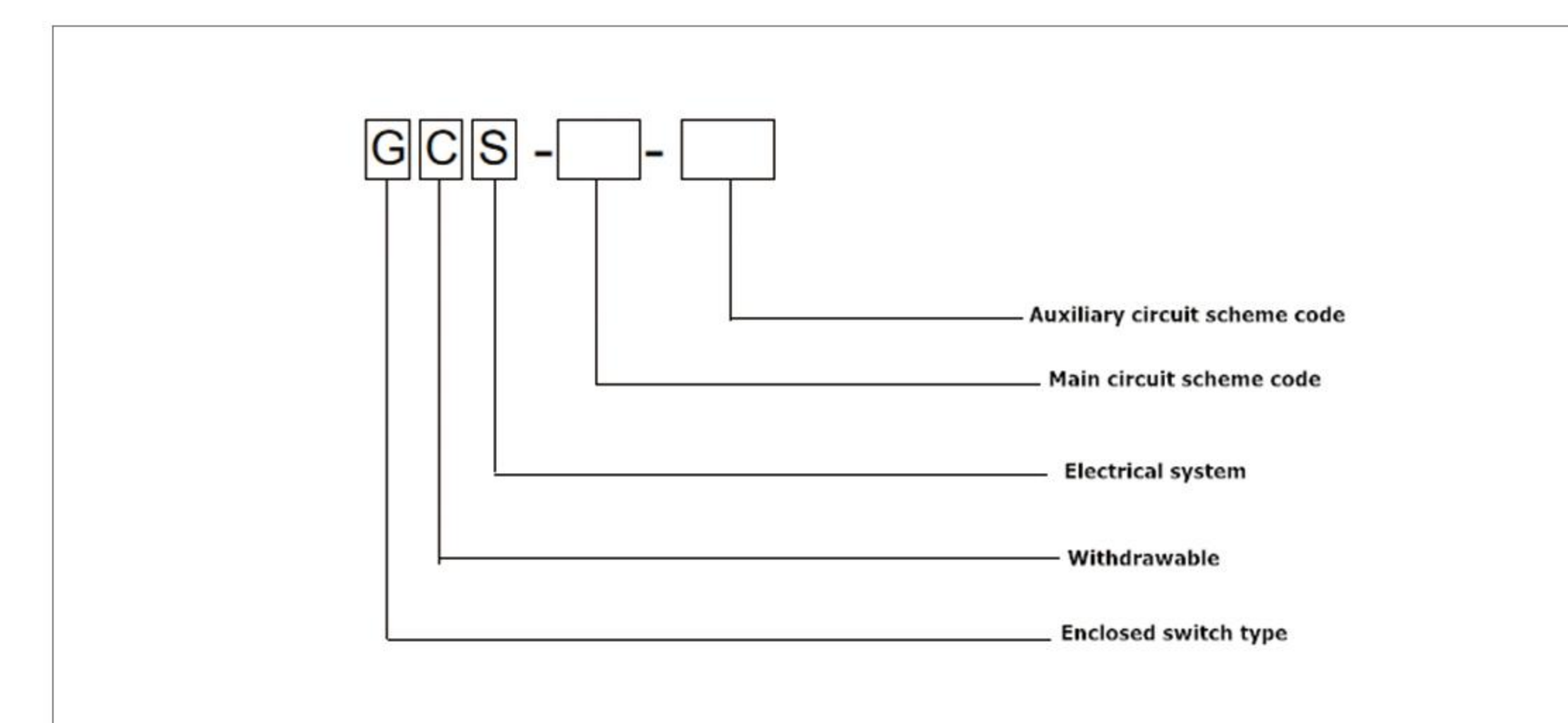

### Product Standard

- + IEC439-1 "Low-voltage Complete Switch and Control Equipment"
- + GB7251 "Low-voltage Complete Switchgear"
- + ZBK36001 "Low-voltage Withdrawable Switchgear"



## Using Environment

- + The ambient air temperature is not higher than +40°C and not lower than -5°C.
- + For indoor use, the altitude of the place of use shall not exceed 2000m.
- + When the device is installed, the inclination to the vertical plane should not exceed 5°, and the whole group of cabinets should be relatively flat (in accordance with GBJ232-82 standard).
- + The device should be installed in a place where there is no violent vibration and impact and not enough to cause undue corrosion on electrical components.

**We can also customize according to your demand.**

## Technical Parameter

Rated Voltage of Main Circuit		AC 380/400/600
Rated voltage of auxiliary circuit (V)		AC 220, 380(400) DC 110,220
Rated phase (Hz)		50(60)
Rated insulation voltage (V)		600(1000)
Rated current (A)	Horizontal bus	≤4000
	Vertical bus (MCC)	1000
Busbar rated short-time withstand current (kA/1s)		50,80
Busbar rated peak withstand current (kA/0.1s)		105,176
Power frequency test voltage (V/1min)	Main circuit	2500
	Auxiliary circuit	1760
Busbar	Three-phase four-wire system	A.B.C.PEN
	Three-phase five-wire system	A.B.C.PE.N
Protection level		IP30 . IP40

### Cabinet Dimension

Height (mm)	2000									
Width (mm)	400		600		800			1000		
Height (mm)	800	1000	800	1000	600	800	1000	600	800	1000

## GGD Low - Voltage Switchgear Panel,Fixed Type

GGD Low - Voltage Switchgear Panel,Fixed Type also called GGD fixed cabinet, is a GGD type AC low-voltage power distribution cabinet used for fixed wiring low-voltage power distribution cabinets. It is divided into three types: GGD1/GGD2/GGD3, with different segment current capabilities.



## Application Channels

Used for power users such as power plants, substations, factories and mines, as AC 50-60Hz, used in power distribution systems with rated operating currents up to 3150A. Used for power conversion, distribution and control of power, lighting and power distribution equipment.

## Cabinet structure

- + The cabinet frame is partially welded and assembled with 8MF cold-formed steel.
- + The ZMJ type busbar clamp, which is thermoformed with high flame retardant PPO material, has a modular structure with high mechanical strength and insulation.
- + The cabinet door is connected to the frame with a galvanized shaft hinge, which is convenient for installation and disassembly.
- + The grounding knurled screw structure is used between the installation parts in the cabinet and the frame to form a complete grounding protection circuit.

## Model Implication

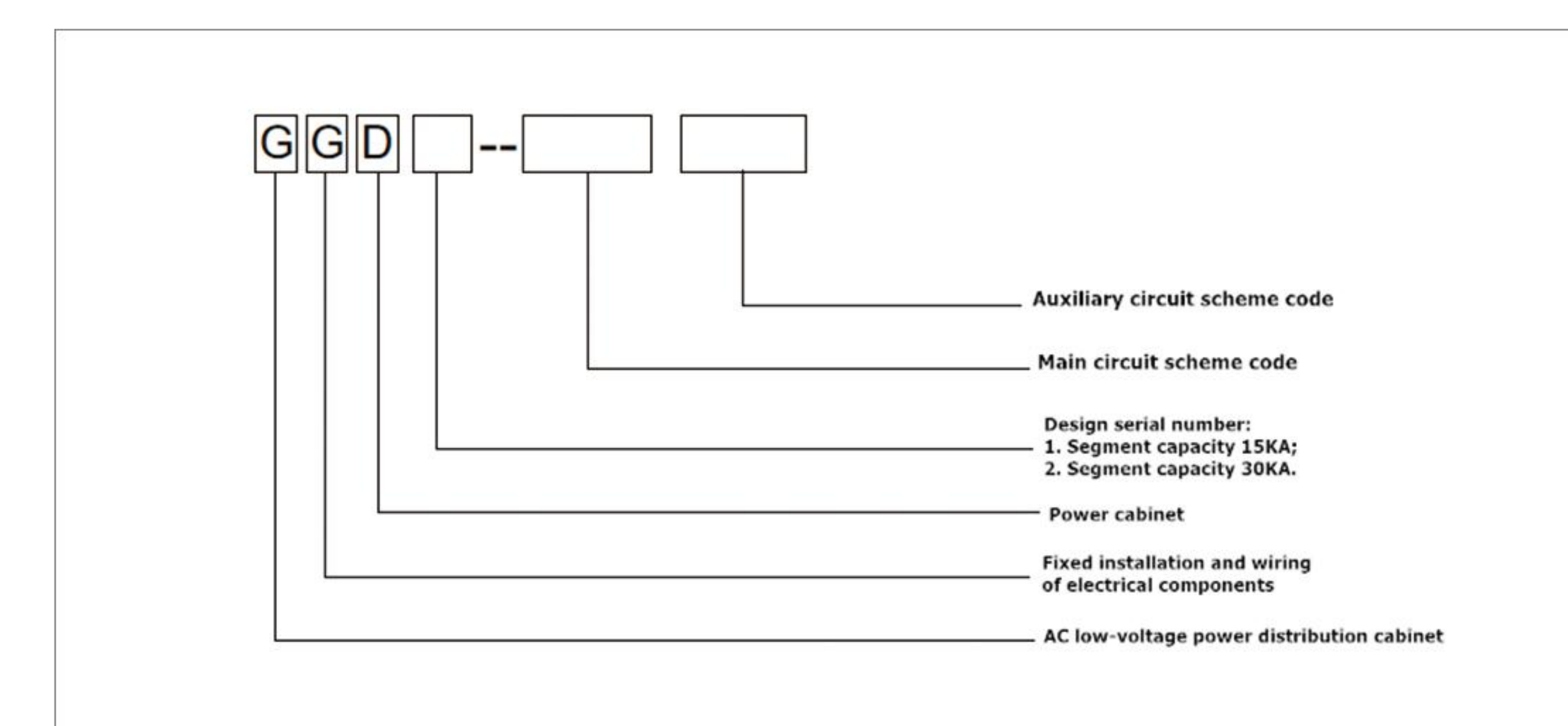

## Product Standard

- + IEC439 "Low-voltage Complete Equipment and Switchgear";
- + GB7251.1-97 "Low-voltage Complete Switchgear";
- + GB/T4942.2-93 "Enclosure Protection Grade of Low-voltage Electrical Apparatus".

## Using Environment

- + The ambient temperature is not higher than +40°C and not lower than -5°C.
  - + When the product is installed and used, the altitude of the place of use should not exceed 2000M.
  - + The relative humidity of the surrounding air is not more than 90% (+25°C).
  - + The relative humidity of the surrounding air does not exceed 5% when the maximum temperature is 40 degrees.
- A larger relative temperature is allowed at a lower temperature. It should be considered that the influence of condensation may occur due to temperature changes.

**We can also customize according to your demand.**

## Technical Parameter

Model	Rated Voltage (V)	Rated Current (A)		Rated Short-circuit Breaking Current (KA)	Rated Short-time Withstand Current (1S) (KA)	Rated Peak Withstand Current (KA)
		A	B			
GGD1	380	A	1000	15	15	30
		B	600(630)			
		C	400			
GGD2	380	A	155(1600)	30	30	65
		B	1000			
		C	600			
GGD3	380	A	3150	50	50	105
		B	2500			
		C	2000			

## Model Implication

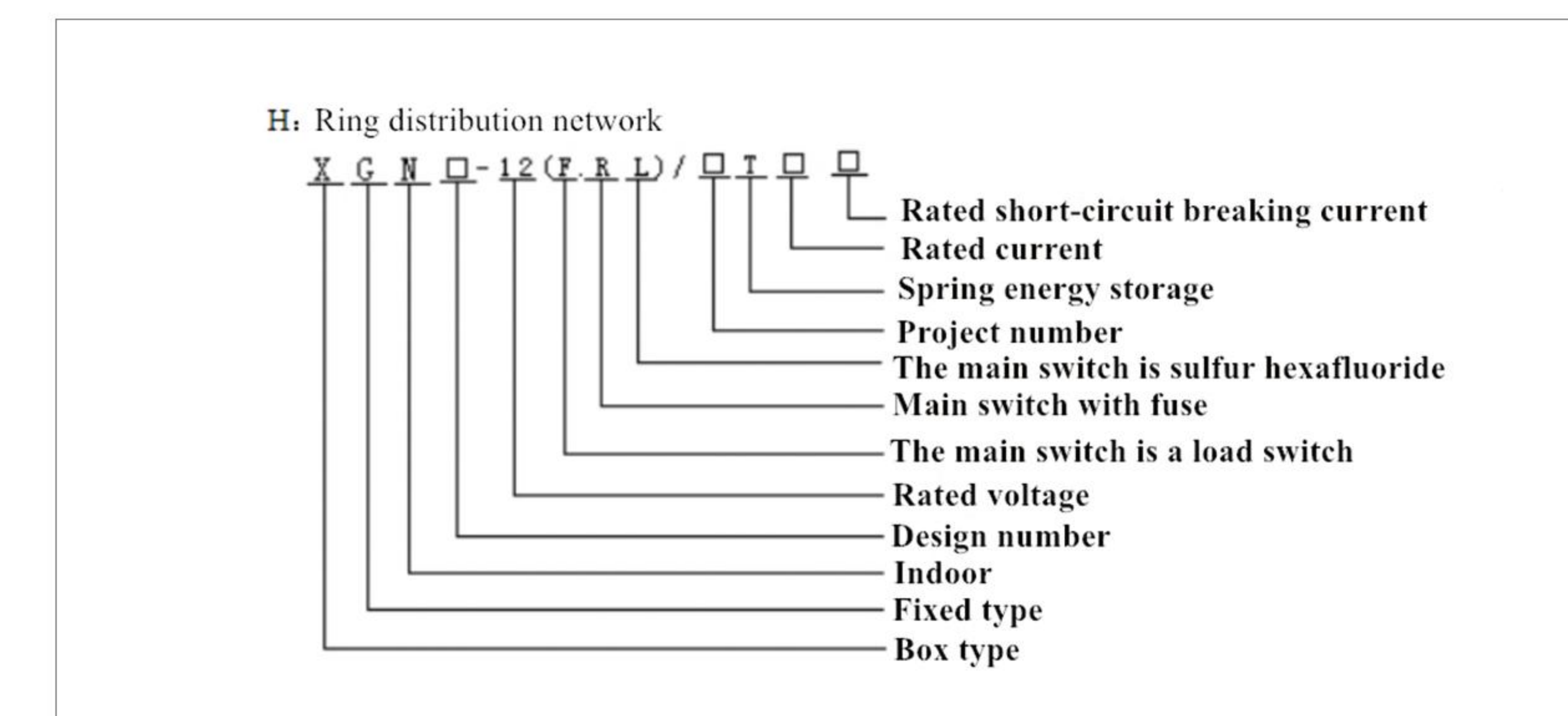

## Product Standard

GB3906-3.6KV~40.5KV AC Metal Enclosed Switchgear and Control Equipment  
GB16926-AC High Voltage Load Switch Fuse Combination Electrical Appliance

## Using Environment

- + The altitude does not exceed 2000m;
- + Ambient temperature: high temperature +40°C, low temperature -5°C;
- + Daily temperature difference: no more than 35°C;
- + Relative humidity : when the highest temperature is +40 °C, it does not exceed the lower temperature when the oil is allowed to be larger relative humidity : such as 90% at +20°C, it should be taken into account that due to temperature changes may occasionally produce condensation.
- +The switchgear should be installed in a place where there is no violent vibration, impact and not enough the cause the electrical components to receive undue corrosion

**We can also customize according to your demand.**

## HXGN-12 Series High Voltage Switchgears

HXGN-12 Series High Voltage Switchgear refer to the switchgears used in the ring power distribution network. The structure of the switchgear is simple, and the combination of load switch and fuse is commonly used. It has simple structure, small size and low price. It can improve the power supply parameters and performance, as well as the advantages of power supply safety.



## Application Channels

Widely used in industrial and civil cable ring networks and power terminals, as the reception and distribution of electric energy, especially suitable for urban residential area power distribution, small secondary power distribution stations, small opening and closing stations, industrial and mining enterprises, shopping malls, airports, subways, power stations, hospitals, stadiums, railways, tunnels and other places.

## Product Features

- 1.HXGN 10KV AC modular SF6 ring network switchgear is a new generation of metal-clad and fully enclosed switchgear with SF6 load switch as the main switch.
- 2.The whole cabinet adopts air insulation, compact and simple structure, flexible operation, convenient installation, multiple interlocks, equipped with electric mechanism, PT, CT, UPS, etc., which can be used in the distribution network automation system.



## Technical Parameter

No.	Item		Unit	Load Switch Cabinet	Combined Electrical Cabinet
1	Rated voltage		KV		12
2	Rated power		Hz		50/60
3	Rated insulation level	1 min power frequency withstand voltage	Alternately and relatively	KV	42
			Isolation fracture		48
		Lightning impulse withstand voltage	Alternately and relatively		75
			Isolation fracture		85
4	Rated current of main bus		A	630	125
5	Rated shore-time withstand current		KA/4S	20	20
6	Rated peak withstand current		KA	50	50
7	Rated AC current		A		3150
8	Rated short-circuit making current (peak value)		KA	50	50
9	Rated short-circuit breaking current (effective value)		KA		31.5
10	Rated active load breaking current		A	630	
11	Ground loop dynamic stability current (peak value)		KA		50
12	Ground loop thermal stability current		KA/2		20
13	Mechanical life	Vacuum load switch	Time		10000
		Earthing switch	Time		2000
14	Auxiliary circuit 1min power frequency withstand voltage		KV		2
15	Working voltage of electric operating mechanism		V	AC220/110; DC220/110	
16	Enclosure rating			IP2X、IP3X	

## KYN28A-12 (Z) Metalclad AC Enclosed Switchgear WitsdrawableType

KYN28A-12 is a relatively common high-voltage switchgear at present in China with full name- indoor metal armored removable switchgear. Its rated voltage is 3.6kV~12kV. The equipped vacuum circuit breaker is in the middle of the switch cabinet, that is, the circuit breaker is located in the middle of the front cabinet of the switchgear, so the lower space can be saved for the expansion of other schemes or used as a cable room. The switchgear meets IEC,GB3906-91. In addition to be used with domestic VS1 vacuum circuit breaker, it can also be used with VD4 from ABB, 3AH5 from Siemens domestic ZN65A, and VB2 from GE, etc., it is truly a power distribution device with good performance.



## Product Standard

IEC298 "AC Metal-enclosed Switchgear and Control Equipment with Rated Voltage 1KV and Below"

IEC694 "High Voltage Switch and Control Equipment Sharing Clause"

GB3906 "3-36KV AC Metal Enclosed Switchgear"

DL404 "Order Conditions for Indoor AC High Voltage Switchgear"

## Product Features

- + Safe and reliable: the compartments in the cabinet are all independent small compartments separated from each other; perfect "five prevention" interlocking function, reliably preventing misoperation and erroneous entry into the live interval; quick closing grounding switch to achieve reliable protective grounding.
- + Flexible solutions: The switch cabinet has a complete set of solutions, which can flexibly form various system solutions to meet customer requirements; according to the application environment and special requirements, it can also provide high altitude series products, double bus series and various non-standard solutions.
- + Strong practicability: the cabinet shell has high sealing strength to prevent the equipment from being invaded by sundries and insects.

## Model Implication:

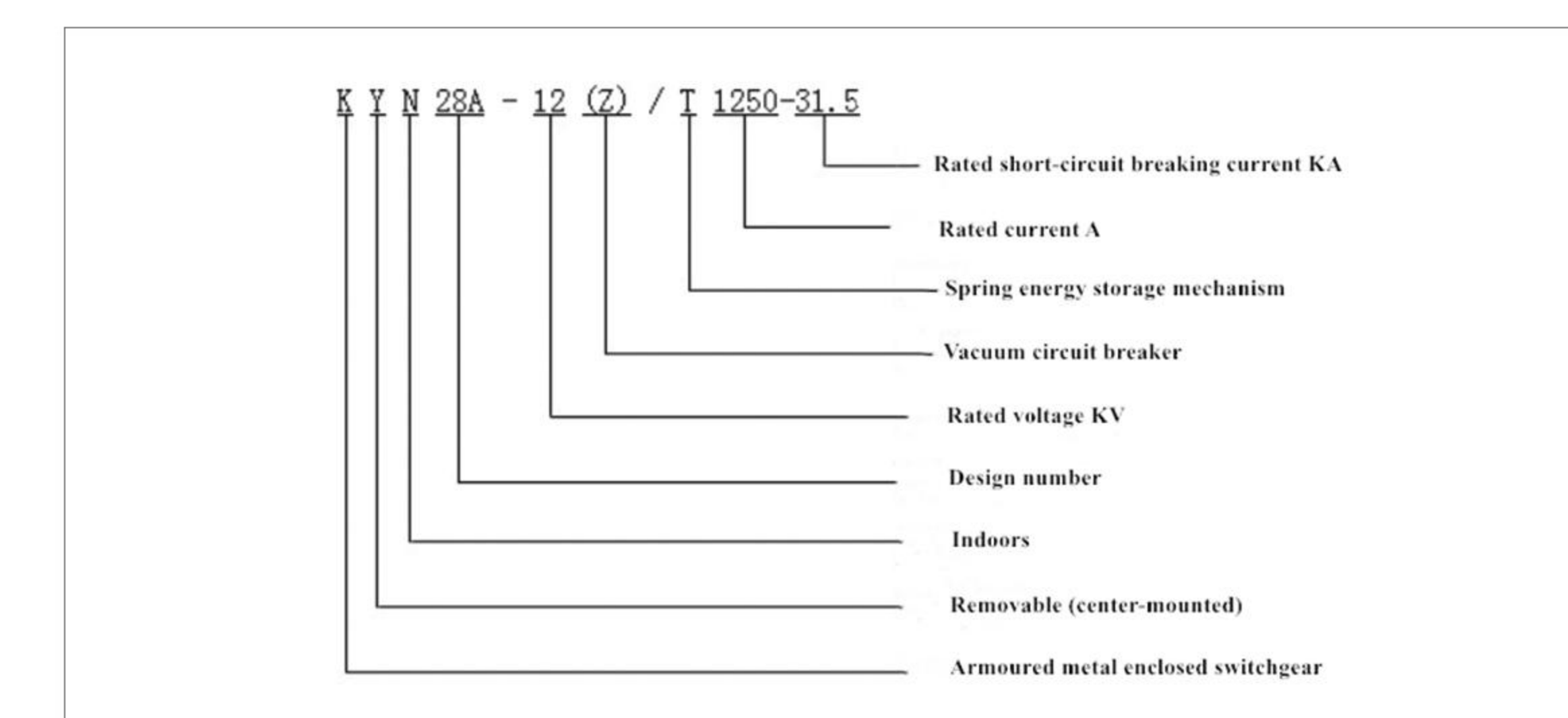

## Using Environment

- + The highest ambient temperature does not exceed +40°C, and the lowest does not exceed -5°C.
- + Relative humidity : when the highest temperature is +40 °C, it does not exceed the lower temperature when the oil is allowed to be larger relative humidity : such as 90% at +20°C, it should be taken into account that due to temperature changes may occasionally produce condensation.
- + The altitude does not exceed 2000m.
- + The switchgear should be installed in a place where there is no violent vibration, impact and not enough the cause the electrical components to receive undue corrosion

**We can also customize according to your demand.**

## Technical Parameter

No.	Item	Unit	Technical Parameter
1	Rated voltage	KV	12
2	Rated current	A	1250
3	Rated short-time power frequency withstand voltage (effective value)	KV	42
4	Rated lightning impulse withstand voltage (peak value)	KV	75
5	Rated short-circuit breaking current (effective value)	KA	31.5
6	Rated short-circuit making current (peak value)	KA	80
7	Rated thermal stability current (effective value)	Main circuit (4S)	31.5
		Ground loop (4S)	27.3
8	Rated dynamic stability current (peak value)	Main circuit	80
		Ground loop	68.3
9	Protection level		

## The Company's Scientific Research Strength /Personnel Strength

### Manufacturing Environment



### Intelligent Production Workshop

The company owns three plant areas A, B, and C with a total construction area of 60,000 square meters. Plant A mainly produces oil-immersed transformers, Plant B mainly produces dry-type transformers, box-type substations, and high and low voltage package units. Plant C, is the Zhongyuan Electric City, which is built under the holding of TSTY Electric. In the future, it will develop into a comprehensive professional park integrating R&D, manufacturing and installation of transmission and distribution equipment and main electrical components. This project covers an area of 289 acres and is built in two phases with a total investment of RMB 1.1 billion, composed of 7 projects, the park aims to promote the transformation of scientific and technological achievements, cultivate high-tech enterprises with technological innovation and business model innovation in the intelligent electrical industry, and build the largest intelligent electrical incubation base in Henan Province.



66 R&D experts and engineers



a provincial engineering technology research center  
a municipal engineering technology research center  
a municipal key laboratory



more than 20 R&D personnel in cooperation with universities  
and research institutes

The company owns Henan Triangle Energy-saving Transformer Engineering Technology Research Center, Pingdingshan City Three-dimensional Triangle Energy-saving Transformer Engineering Technology Research Center, and Pingdingshan City On-load Capacity Regulation Transformer Key Laboratory, etc., with complete testing equipment, engineering technical test conditions and infrastructure. There are more than 50 sets of various equipment and testing instruments, worth more than RMB 17.27 million. The company invested RMB 7.9 million in research and development in 2019. So far, the company has been authorized with 109 patents by the State, including 18 inventions and 101 utility models.





# Corporate Culture

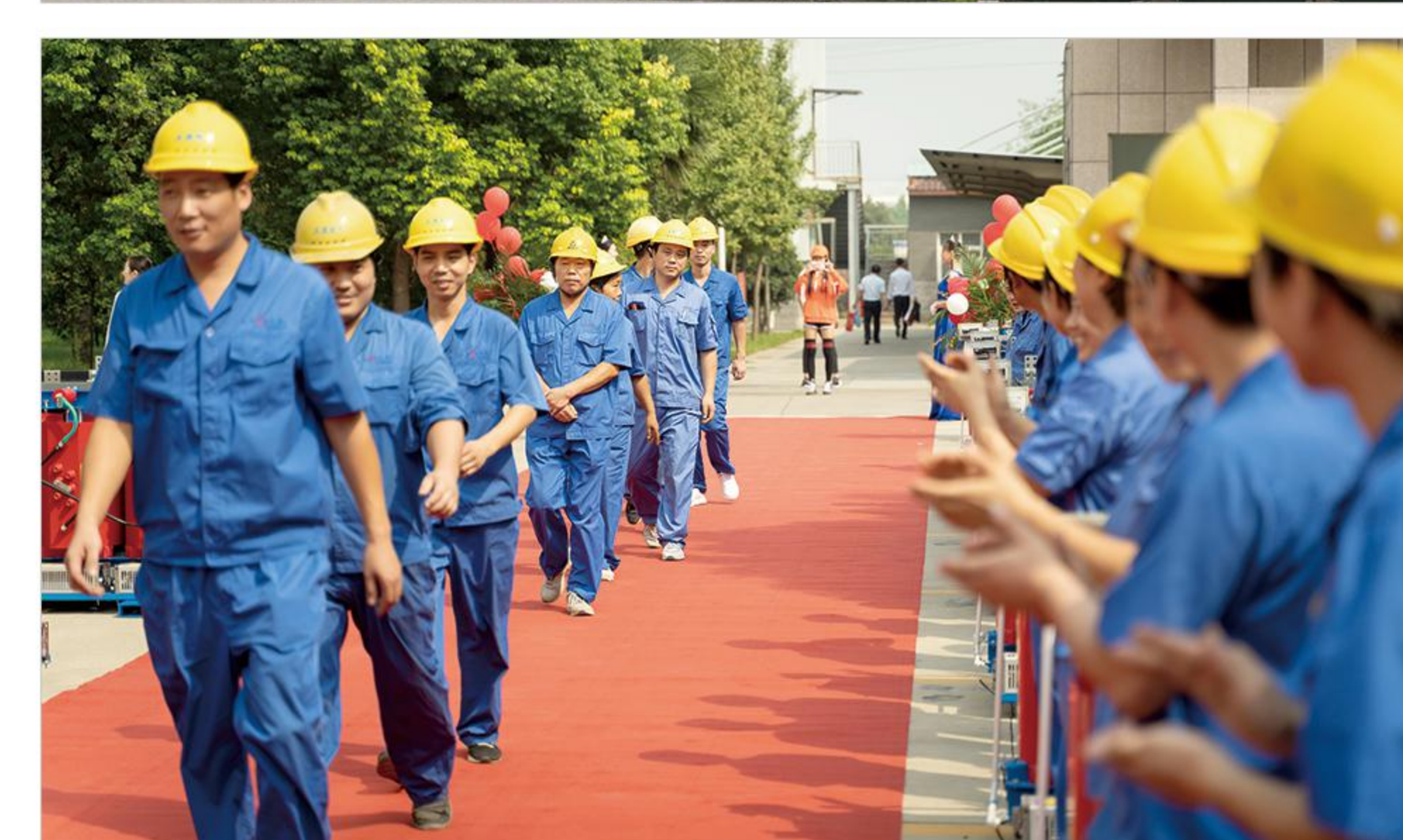

## Annual meeting activities



## Factory Shipment



# Achievements

TSTY is accepted by the market and customers with its high-quality products and perfect service, the achievements we got in these years as follows:

## Export

TSTY is one World-class intelligent manufacturing enterprise, its transformers such as oil immersed transformers and dry type transformers produced were exported to Mexico, Colombia, Indonesia, Nigeria, Zambia, Malaysia and so on.



## Grid

Our products were used widely in the State Grid and South Grid by winning tenders and bulk supply. Now TSTY is already one outstanding supplier to State Grid and South Grid. Of which, in the renovation project of Hubei province, TSTY became one of three large suppliers by providing more than 1000 sets transformers; in the renovation project of Henan province, TSTY supplied pole-mounted complete equipments for transformer, switch cabinet, dry-type transformer, the total quantity up to 2000 sets in this project.

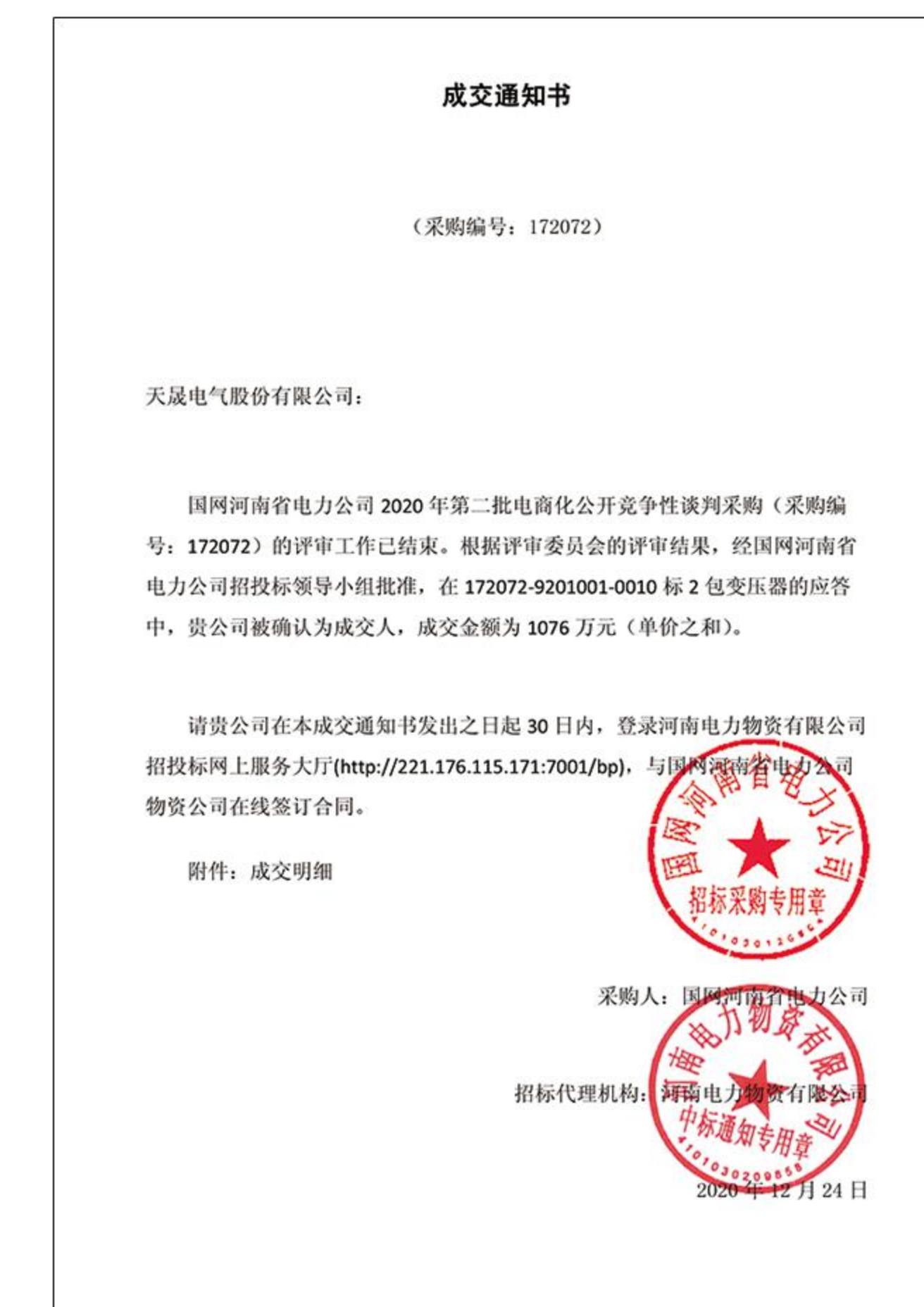
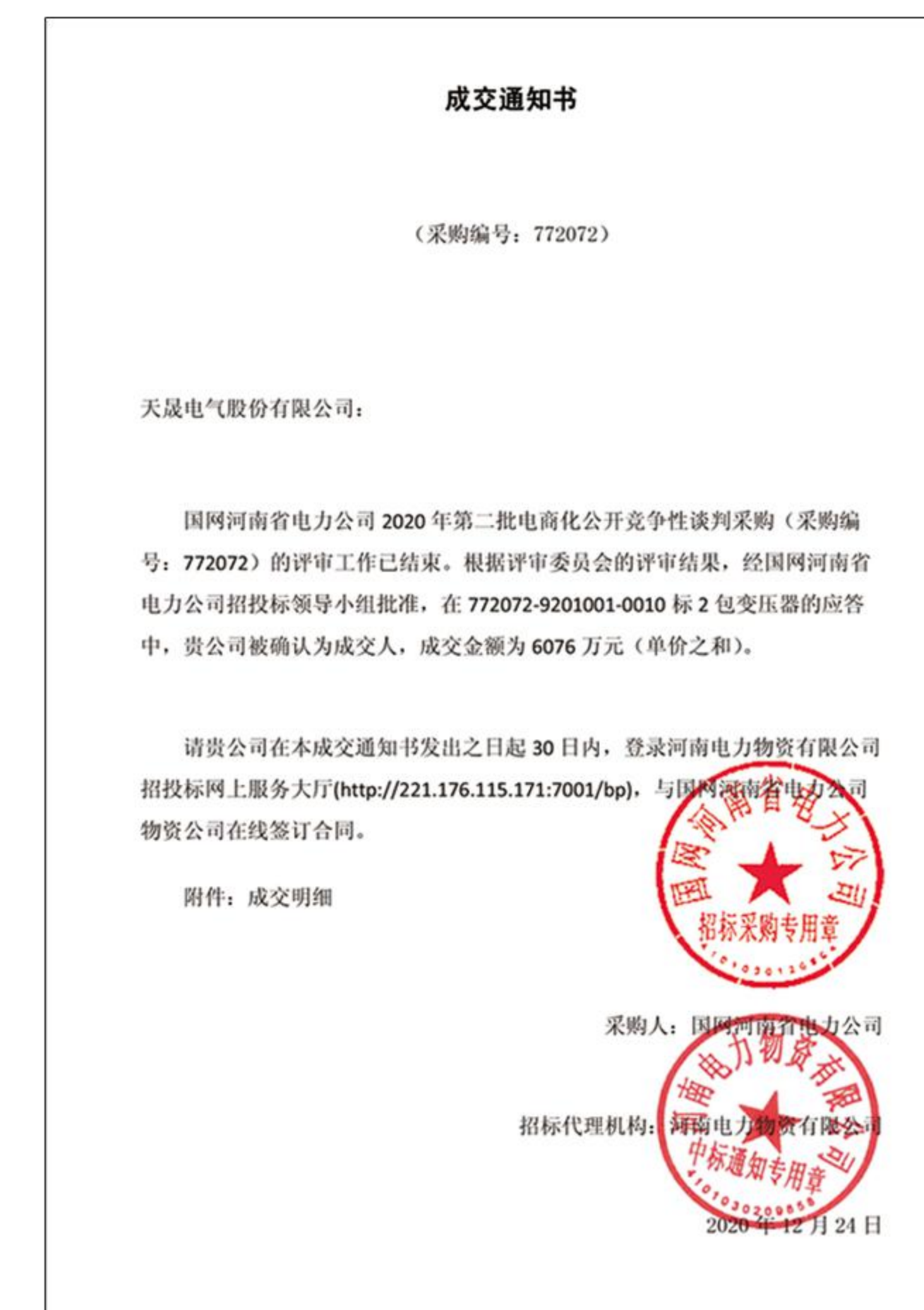
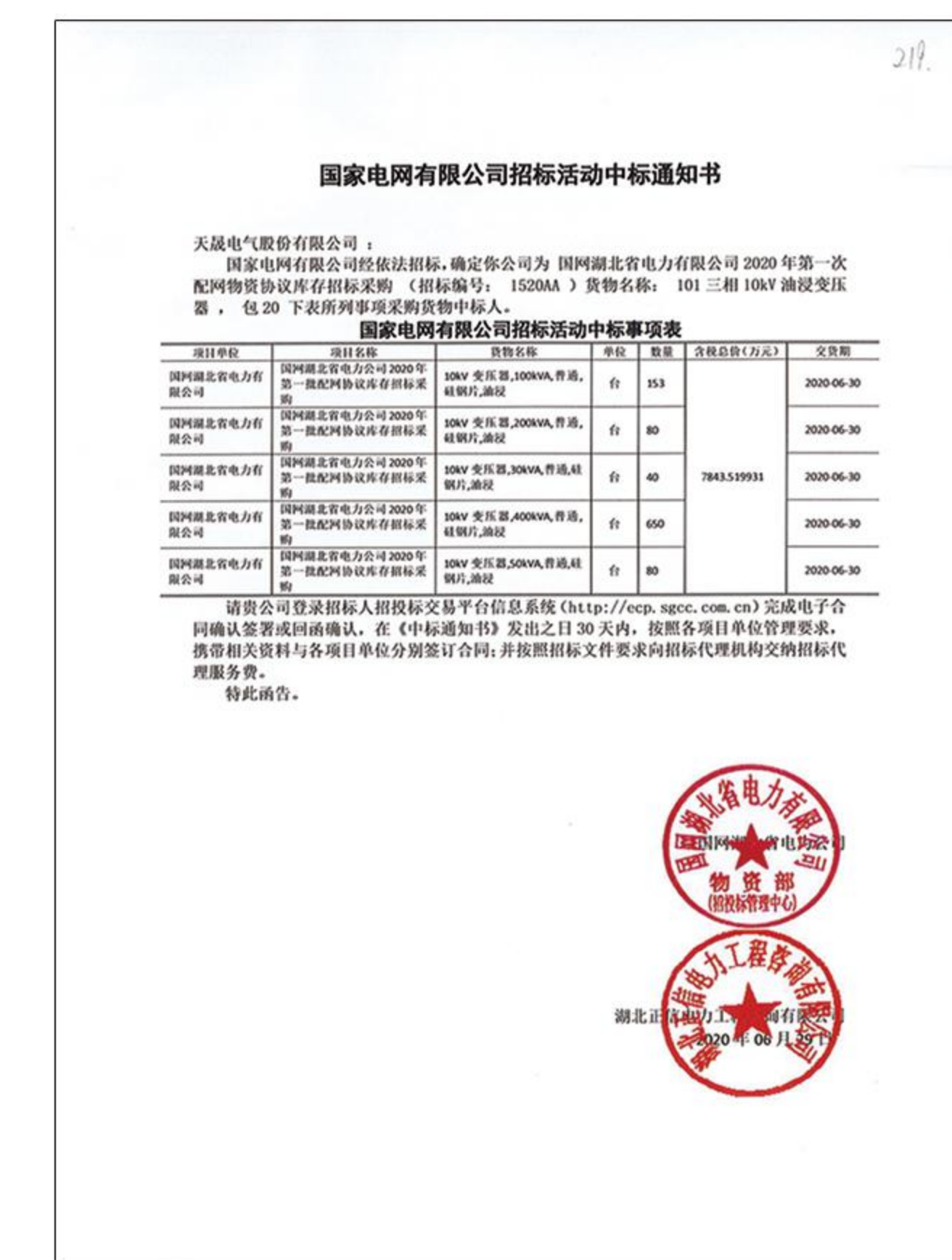

# Corporate Performance

## Power Supply Project

In the new energy wind power generation project, TSTY became an excellent supplier in the fifth-largest wind power station with its oil immersed transformer. The projects we have participated in are wind station in Jiangsu Longyuan Rudong, wind station in north-east of Hebei Weichang Manchu and Mongolian Autonomous prefecture, wind power generation station in Changdao CLP, 100MW wind power project in Mangya New Energy Wind Power Haixi Co., Ltd. CGN, 30MW decentralized wind power station in Jianzha beach Jianzha prefecture Huangnan state CGN, Yunwuyu wind power project in Fanzhi prefecture Shanxi, Wind Power in Cengang Zhoushan, wind power 1st stage in Zhucheng prefecture Shandong province, etc. and TSTY provided complete equipment for oil immersed transformer in these projects. Now, TSTY is becoming the outstanding brand in the energy power generation field.



## Projects in Customer End

Beyond the customers from grid and power generation field, TSTY's another main market is large companies. Until now, we supply high-quality products for domestic famous companies, such as, South to North Water Diversion Project, Qinghai Tibet railway, Jiangxi Hongdu Aviation, Shanghai Meishan Steel Group, Hainan Steel Group, Xin Steel Group, Aluminum Corporation of China, Guangxi Huayin Aluminum Corporation, Jiangxi Copper Corporation Limited, Xinjiang Xinxin Mining Industry Co., Ltd., Shengli Oilfield, Jiangnan Oilfield, Henan Oilfield, Shaanxi Yanchang Oilfield, China Resources Cement, Yunnan Diandong Cement Co., Ltd., Yunnan State-owned Cement Company, Inner Mongolia Chifeng Yuanhang Cement Co., Ltd., Datong Coal Mine Group, Huainan Mining Group, Xinjiang Nonferrous Metals Group, WISCO group, Inner Mongolia Xingye Mining Group, Shanxi Huozhou Coal Group, etc.



# Case overview



yuemei textile factory



Case study



Photovoltaic



Photovoltaic



National Grid China Southern Power Grid



Case study



Case study



Qinghai-Tibet Railway



Qinghai-Tibet Railway



National Grid China Southern Power Grid



Daqing Oilfield



Daqing Oilfield



Wanfang Chemical Group



Wanfang Chemical Group

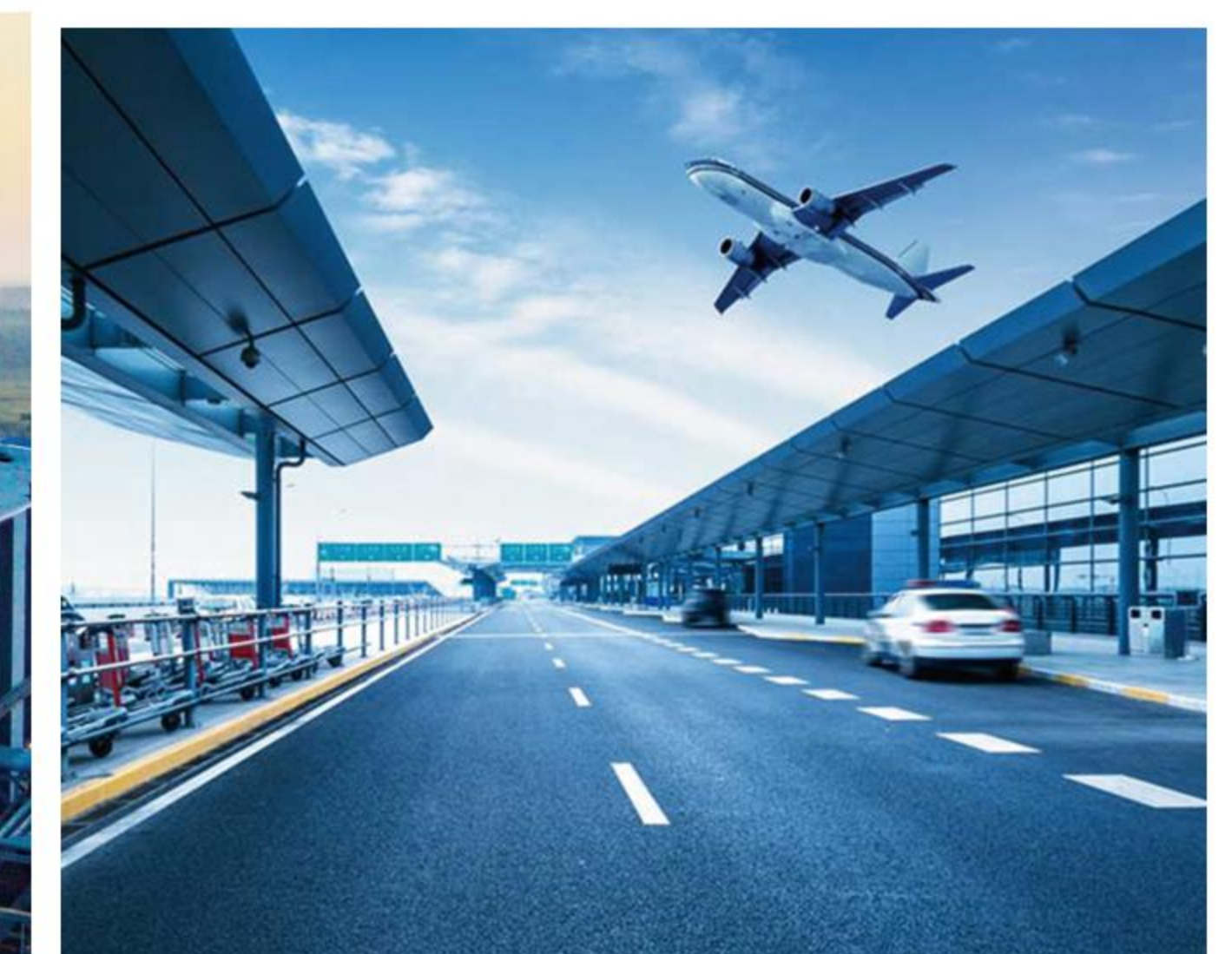

Shenzhen Airport

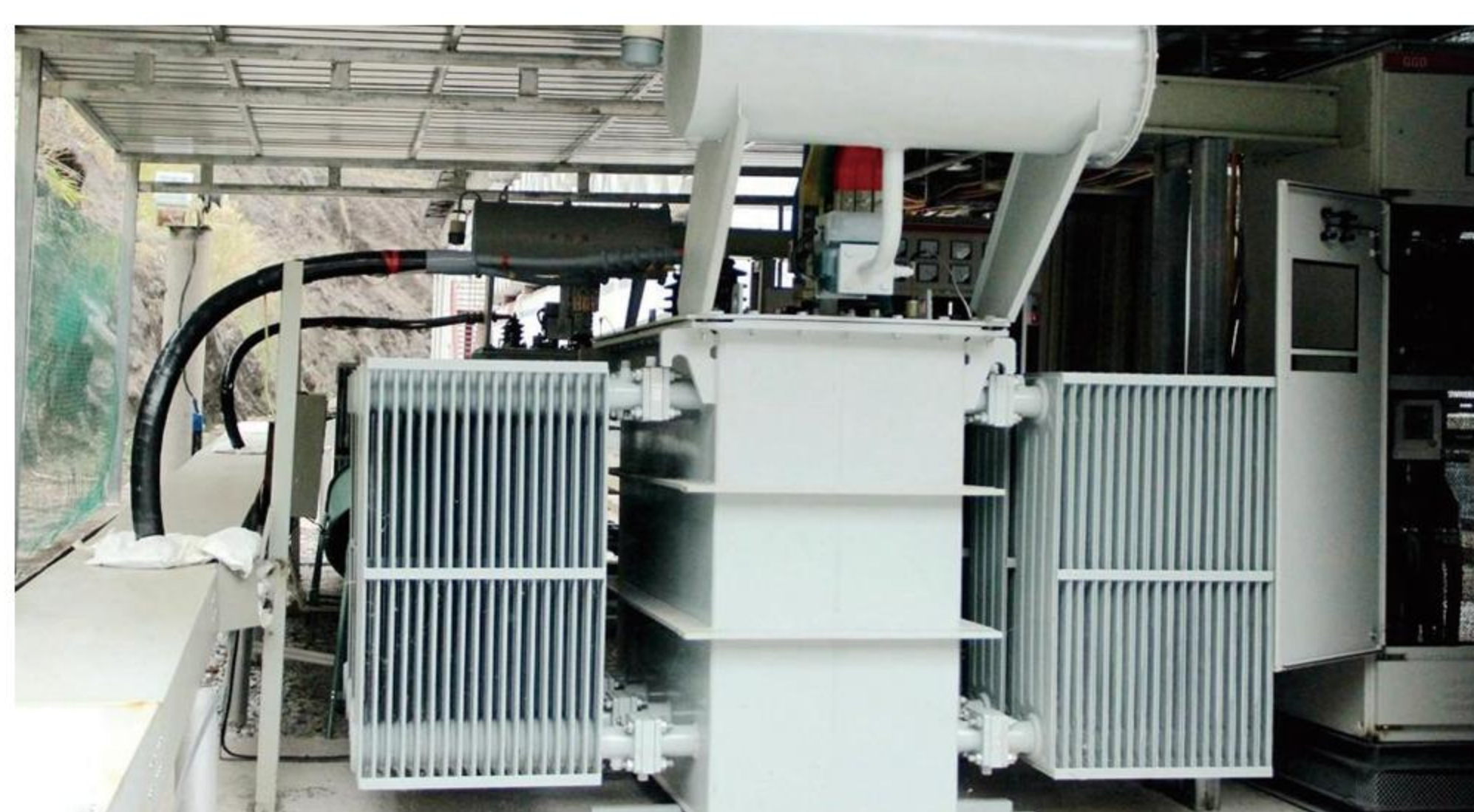

Datong Coal Mine



Datong Coal Mine



Zhengwan High Speed Rail



government building



Zhengwan High Speed Rail