

iVascular[®]

therapies for living

sergeant

peripheral support catheter

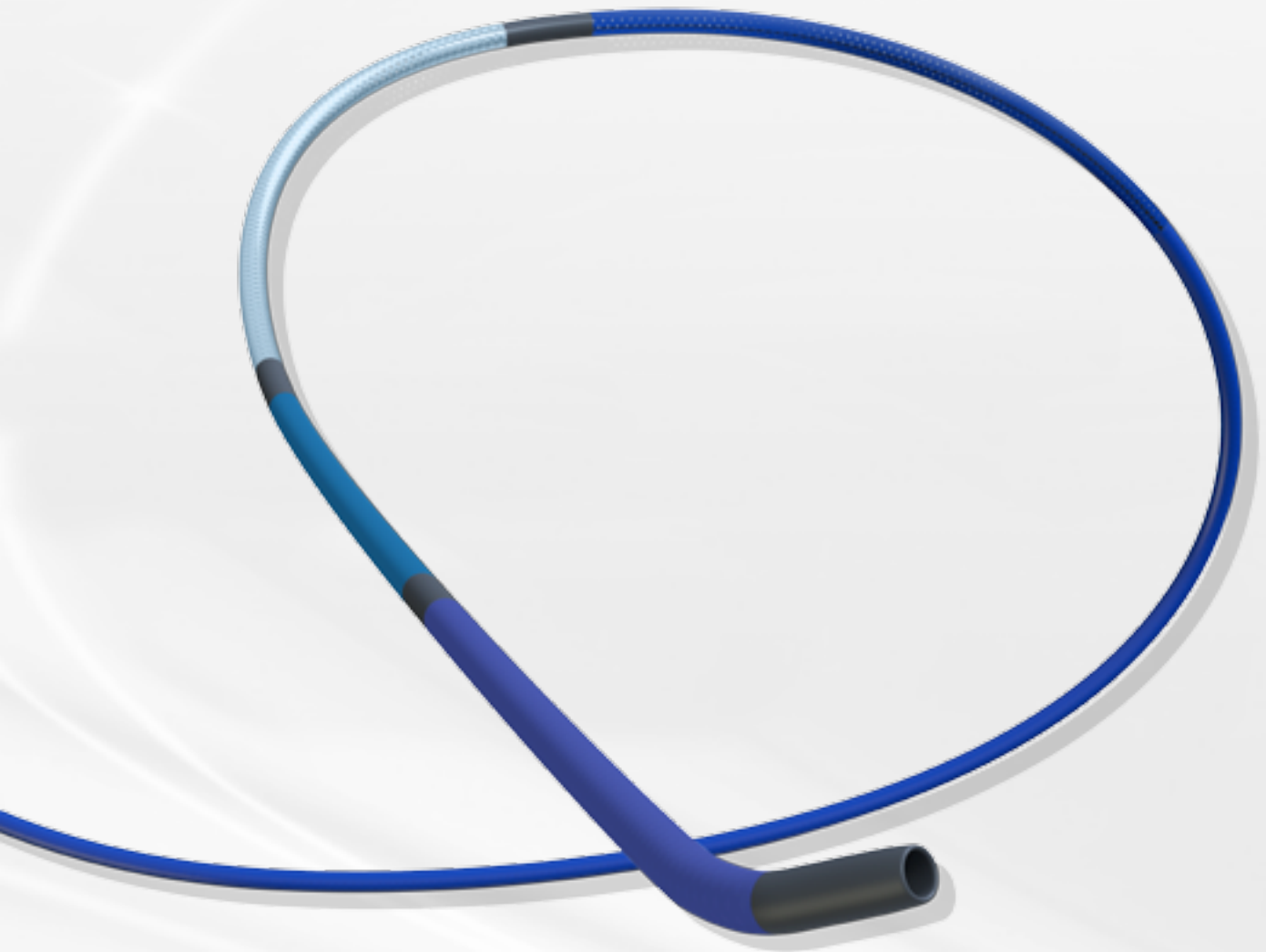

To lead complex lesions procedures



www.ivascular.global

sergeant

Designed to ease the complex and distal lesions procedures

Support to cross all lesions

Developed to ensure an outstanding guidewire support:

- Braided catheter with exceptional pushability and torque capacity
- Tapered shaft design to increase support



Able to go through tortuous anatomy

HYDRAX +, proprietary hydrophilic coating that increases the catheter trackability

Perfect visibility

The 4 radiopaque markers assess accurately:

- Catheter position
- Lesion length

sergeant features

- > **Over the wire catheter (OTW)**
- > Tip: **Straight or 30° Angled**

- > **4 tungsten radiopaque markers**
- > **4F** introducer compatible

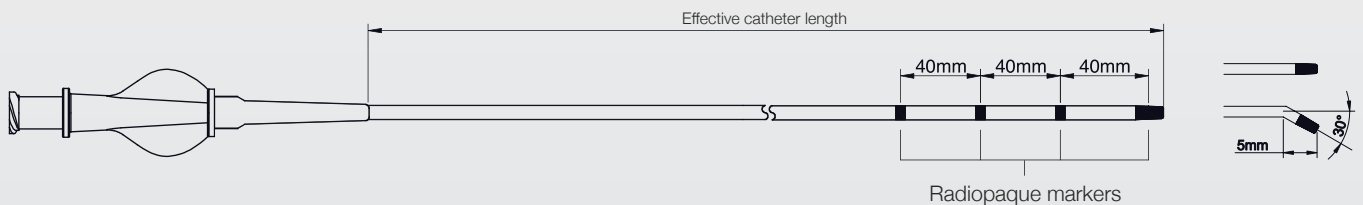

Product with CE mark, certified by Notified Body 0123

Guidewire compatibility	Effective catheter length (cm)				Tip shape
	65	90	130	150	
0.014"	DSP C14 065 001	DSP C14 090 001	DSP C14 130 001	DSP C14 150 001	Straight
	DSP C14 065 002	DSP C14 090 002	DSP C14 130 002	DSP C14 150 002	Angled
0.018"	DSP C18 065 001	DSP C18 090 001	DSP C18 130 001	DSP C18 150 001	Straight
	DSP C18 065 002	DSP C18 090 002	DSP C18 130 002	DSP C18 150 002	Angled
0.035"	DSP C35 065 001	DSP C35 090 001	DSP C35 130 001	DSP C35 150 001	Straight
	DSP C35 065 002	DSP C35 090 002	DSP C35 130 002	DSP C35 150 002	Angled

Distributed by:

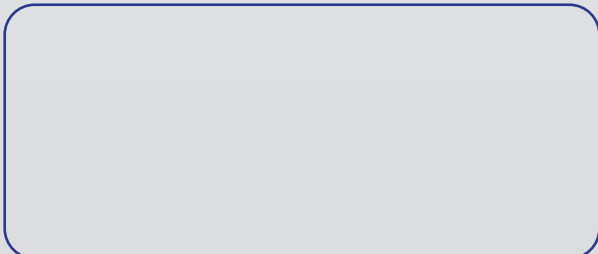

Manufactured by:

Life Vascular Devices Biotech, S.L.
www.ivascular.global
info@ivascular.global

iVascular[®]

therapies for living

oceanus 14 pro

PTA balloon dilatation catheter

To reach the **most challenging** lesions
with the **highest visibility**

Best flexibility
and trackability*

Smallest balloon
diameters

Enhanced
visibility*

Lowest
profiles



Proprietary hydrophilic
durable coating



www.ivascular.global

oceanus 14 pro features

* Radiopaque markers	
	$\varnothing \leq 2.0\text{mm}$, Length $\leq 20\text{mm}$: 1 tungsten marker
	$\varnothing \leq 2.0\text{mm}$, Length $> 20\text{mm}$: 2 tungsten markers
	$\varnothing \geq 2.5\text{mm}$: 2 Pt/Ir markers

- > Over the wire catheter (OTW)
- > Usable Catheter length: 100 cm & 150 cm
- > Guidewire compatibility: 0.014"
- > Tip profile: 0.017"
- > Crossing profile: 0.021" to 0.033"
- > Nominal pressure: 7 atm
- > Rated Burst Pressure (RBP): 16 atm
- > Average Burst Pressure (ABP): 22 atm

Product with CE mark, certified by Notified Body 0318

Usable catheter length	Balloon \varnothing (mm)	Balloon Length (mm)									
		10	15	20	40	60	80	120	150	200	
100 cm	1.25	BP PC14N 100 125 010	BP PC14N 100 125 015	BP PC14N 100 125 020	-	-	-	-	-	-	-
	1.5	BP PC14N 100 150 010	BP PC14N 100 150 015	BP PC14N 100 150 020	BP PC14N 100 150 040	BP PC14N 100 150 060	BP PC14N 100 150 080	-	-	-	-
	2.0	BP PC14N 100 200 010	BP PC14N 100 200 015	BP PC14N 100 200 020	BP PC14N 100 200 040	BP PC14N 100 200 060	BP PC14N 100 200 080	BP PC14N 100 200 120	BP PC14N 100 200 150	BP PC14N 100 200 200	-
	2.5	-	-	-	BP PC14N 100 250 040	BP PC14N 100 250 060	BP PC14N 100 250 080	BP PC14N 100 250 120	BP PC14N 100 250 150	BP PC14N 100 250 200	-
	3.0	-	-	-	BP PC14N 100 300 040	BP PC14N 100 300 060	BP PC14N 100 300 080	BP PC14N 100 300 120	BP PC14N 100 300 150	BP PC14N 100 300 200	-
	3.5	-	-	-	BP PC14N 100 350 040	BP PC14N 100 350 060	BP PC14N 100 350 080	BP PC14N 100 350 120	BP PC14N 100 350 150	BP PC14N 100 350 200	-
	4.0	-	-	-	BP PC14N 100 400 040	BP PC14N 100 400 060	BP PC14N 100 400 080	BP PC14N 100 400 120	-	-	-
150 cm	1.25	BP PC14N 150 125 010	BP PC14N 150 125 015	BP PC14N 150 125 020	-	-	-	-	-	-	-
	1.5	BP PC14N 150 150 010	BP PC14N 150 150 015	BP PC14N 150 150 020	BP PC14N 150 150 040	BP PC14N 150 150 060	BP PC14N 150 150 080	-	-	-	-
	2.0	BP PC14N 150 200 010	BP PC14N 150 200 015	BP PC14N 150 200 020	BP PC14N 150 200 040	BP PC14N 150 200 060	BP PC14N 150 200 080	BP PC14N 150 200 120	BP PC14N 150 200 150	BP PC14N 150 200 200	-
	2.5	-	-	-	BP PC14N 150 250 040	BP PC14N 150 250 060	BP PC14N 150 250 080	BP PC14N 150 250 120	BP PC14N 150 250 150	BP PC14N 150 250 200	-
	3.0	-	-	-	BP PC14N 150 300 040	BP PC14N 150 300 060	BP PC14N 150 300 080	BP PC14N 150 300 120	BP PC14N 150 300 150	BP PC14N 150 300 200	-
	3.5	-	-	-	BP PC14N 150 350 040	BP PC14N 150 350 060	BP PC14N 150 350 080	BP PC14N 150 350 120	BP PC14N 150 350 150	BP PC14N 150 350 200	-
	4.0	-	-	-	BP PC14N 150 400 040	BP PC14N 150 400 060	BP PC14N 150 400 080	BP PC14N 150 400 120	-	-	-

The availability of each reference for the sale is linked to the authorization of commercialization in the country of destination

● Introducer compatibility: 4F

Distributed by:



Manufactured by:

Life Vascular Devices Biotech, S.L.
www.ivascular.global
info@ivascular.global

iVascular[®]

therapies for living

oceanus 35

PTA balloon dilatation catheter

Reach & dilate

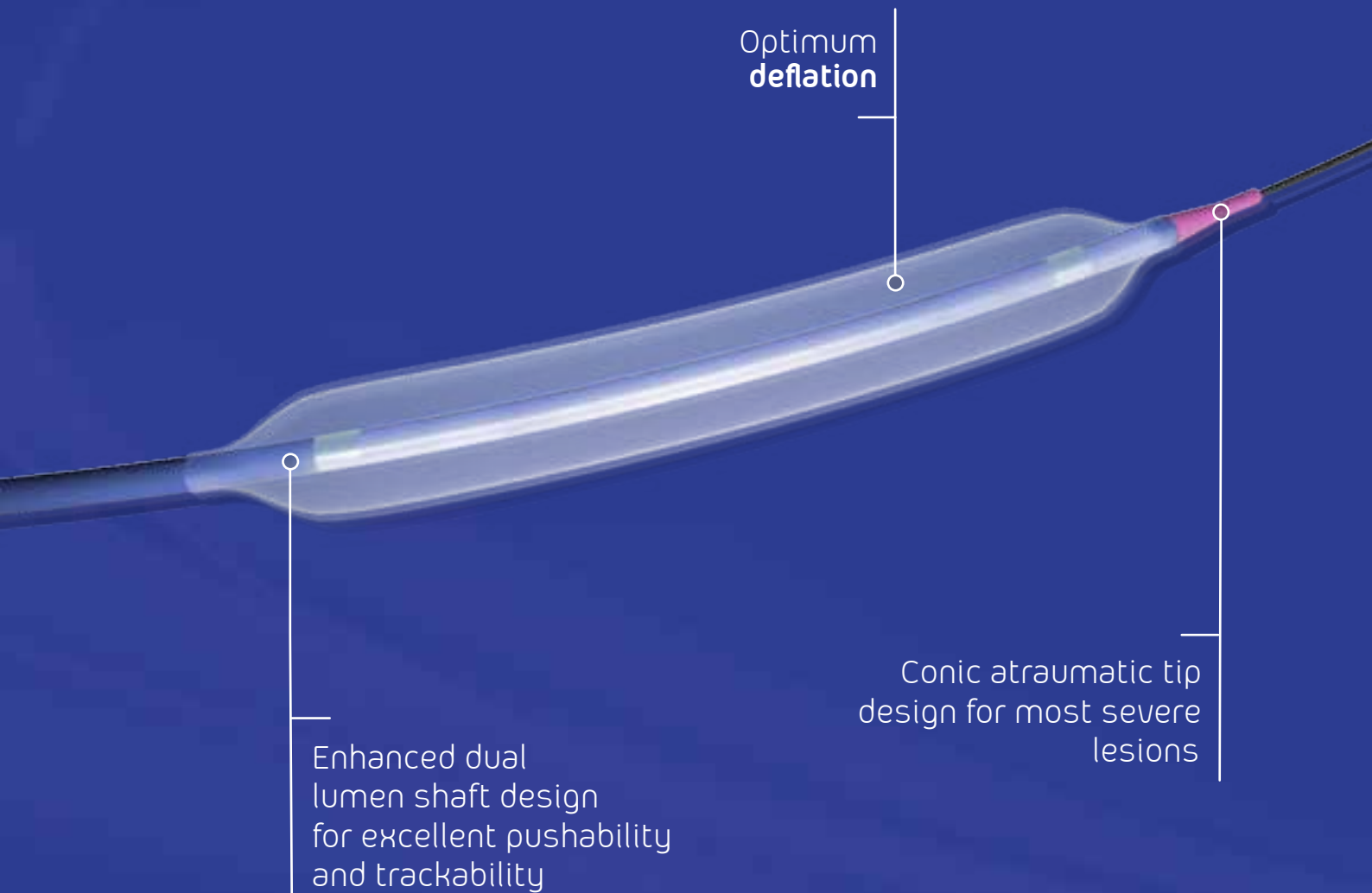

www.ivascular.global

oceanus 35 features

- > **Over the wire** catheter (OTW)
- > Usable Catheter length: **80 cm, 140 cm & 200 cm**
- > Guidewire compatibility: **0.035"**
- > Tip Profile: **0.036"**
- > Crossing profile: from **0.057"** up to **0.083"**

Product with CE mark, certified by Notified Body 0318

OCEANUS 35 Compliance Data

Balloon Diameter (mm)	3mm	4mm	5mm	6mm	7mm	8mm	9mm	10mm	12mm
Nominal Pressure (atm)	7	7	7	6	7	7	6	6	6
Rated Burst Pressure (RBP) (atm)	16*	16	16	16	16	15	14	13	13
Average Burst Pressure (ABP) (atm)	24	24	23	23	23	21	20	20	19

*20 atm: 3mm - L ≤ 60mm

Usable catheter length	Balloon Ø (mm)	Balloon Length (mm)							
		20	40	60	80	120	150	200	
80 cm	3	BP PC35 080 300 020	BP PC35 080 300 040	BP PC35 080 300 060	BP PC35 080 300 080	BP PC35 080 300 120	BP PC35 080 300 150	BP PC35 080 300 200	
	4	BP PC35 080 400 020	BP PC35 080 400 040	BP PC35 080 400 060	BP PC35 080 400 080	BP PC35 080 400 120	BP PC35 080 400 150	BP PC35 080 400 200	
	5	BP PC35 080 500 020	BP PC35 080 500 040	BP PC35 080 500 060	BP PC35 080 500 080	BP PC35 080 500 120	BP PC35 080 500 150	BP PC35 080 500 200	
	6	BP PC35 080 600 020	BP PC35 080 600 040	BP PC35 080 600 060	BP PC35 080 600 080	BP PC35 080 600 120	BP PC35 080 600 150	BP PC35 080 600 200	
	7	BP PC35 080 700 020	BP PC35 080 700 040	BP PC35 080 700 060	BP PC35 080 700 080	BP PC35 080 700 120	-	-	
	8	BP PC35 080 800 020	BP PC35 080 800 040	BP PC35 080 800 060	BP PC35 080 800 080	-	-	-	
	9	BP PC35 080 900 020	BP PC35 080 900 040	BP PC35 080 900 060	BP PC35 080 900 080	-	-	-	
	10	BP PC35 080 100 020	BP PC35 080 100 040	BP PC35 080 100 060	-	-	-	-	
	12	BP PC35 080 120 020	BP PC35 080 120 040	BP PC35 080 120 060	-	-	-	-	
140 cm	3	BP PC35 140 300 020	BP PC35 140 300 040	BP PC35 140 300 060	BP PC35 140 300 080	BP PC35 140 300 120	BP PC35 140 300 150	BP PC35 140 300 200	
	4	BP PC35 140 400 020	BP PC35 140 400 040	BP PC35 140 400 060	BP PC35 140 400 080	BP PC35 140 400 120	BP PC35 140 400 150	BP PC35 140 400 200	
	5	BP PC35 140 500 020	BP PC35 140 500 040	BP PC35 140 500 060	BP PC35 140 500 080	BP PC35 140 500 120	BP PC35 140 500 150	BP PC35 140 500 200	
	6	BP PC35 140 600 020	BP PC35 140 600 040	BP PC35 140 600 060	BP PC35 140 600 080	BP PC35 140 600 120	BP PC35 140 600 150	BP PC35 140 600 200	
	7	BP PC35 140 700 020	BP PC35 140 700 040	BP PC35 140 700 060	BP PC35 140 700 080	BP PC35 140 700 120	-	-	
	8	BP PC35 140 800 020	BP PC35 140 800 040	BP PC35 140 800 060	BP PC35 140 800 080	-	-	-	
	9	BP PC35 140 900 020	BP PC35 140 900 040	BP PC35 140 900 060	BP PC35 140 900 080	-	-	-	
	10	BP PC35 140 100 020	BP PC35 140 100 040	BP PC35 140 100 060	-	-	-	-	
	12	BP PC35 140 120 020	BP PC35 140 120 040	BP PC35 140 120 060	-	-	-	-	
NEW 200 cm	3	-	-	-	-	-	-	-	
	4	-	-	-	-	-	-	-	
	5	-	-	-	-	-	-	-	
	6	BP PC35 200 600 020	-	-	-	-	-	-	
	7	BP PC35 200 700 020	-	-	-	-	-	-	
	8	BP PC35 200 800 020	-	-	-	-	-	-	
	9	BP PC35 200 900 020	-	-	-	-	-	-	

The availability of each reference for the sale is linked to the authorization of commercialization in the country of destination

- Introducer compatibility: **5F**
- Introducer compatibility: **6F**

Distributed by:



Manufactured by:

Life Vascular Devices Biotech, S.L.
www.ivascular.global
info@ivascular.global

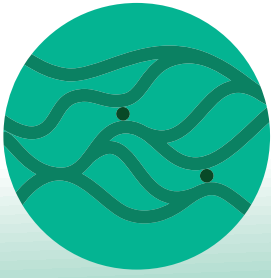

iNtercept

Stent retriever

Designed to restore the blood flow



iVascular[®]
therapies for living

Accuracy in the implantation

Excellent visibility with:

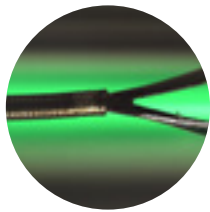

1 Proximal gold marker

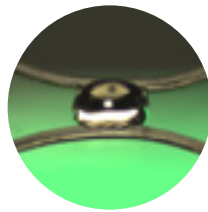

2 Central gold markers arranged in a helical pattern along the length of the basket

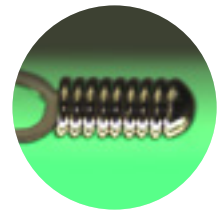

3 Distal platinum markers

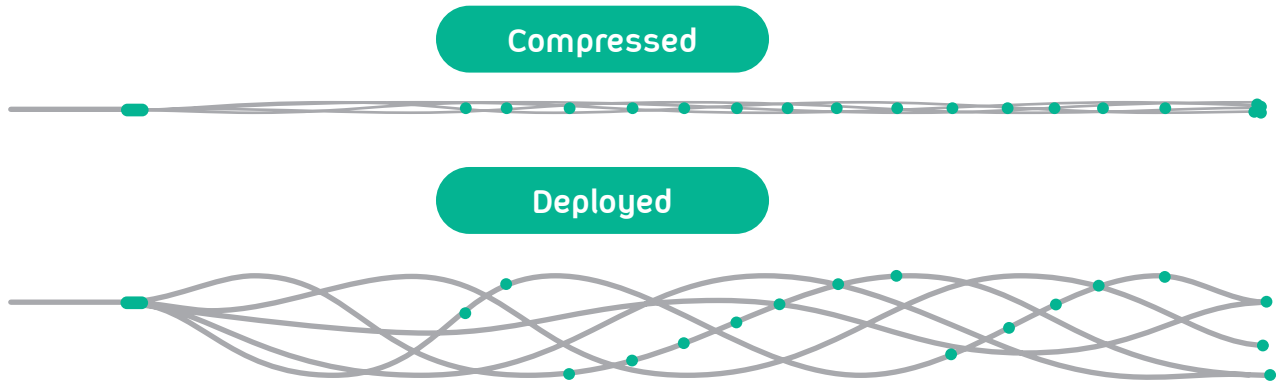

Proximal central marker to help position the retriever relative to the thrombus

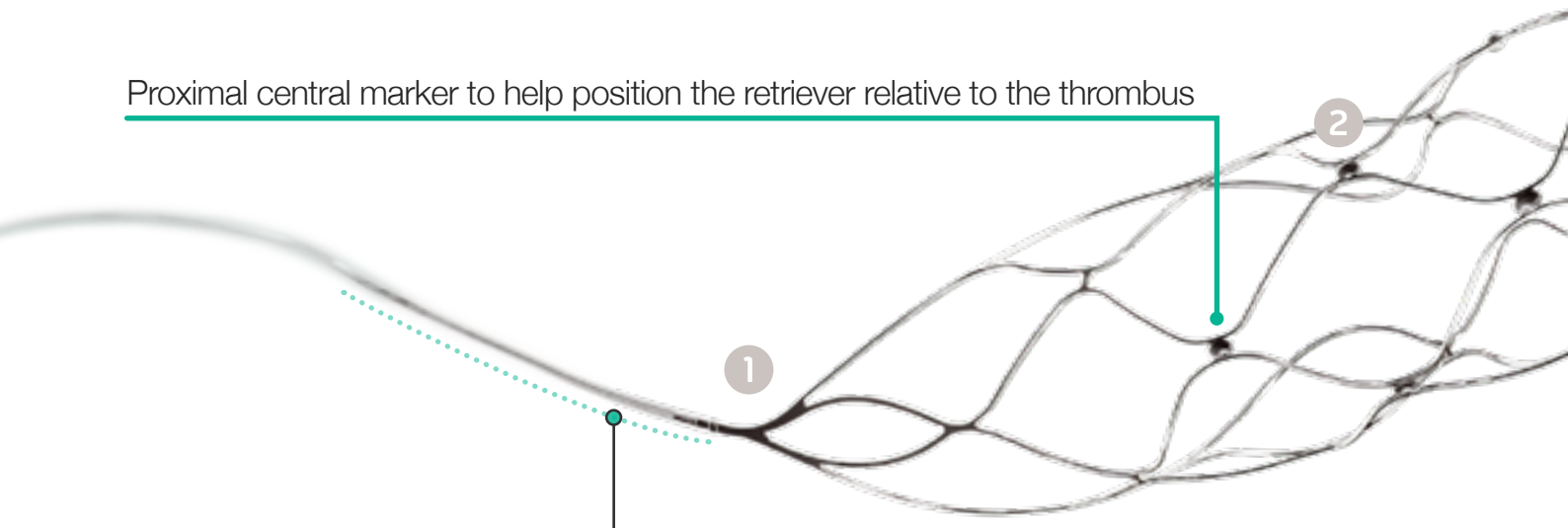

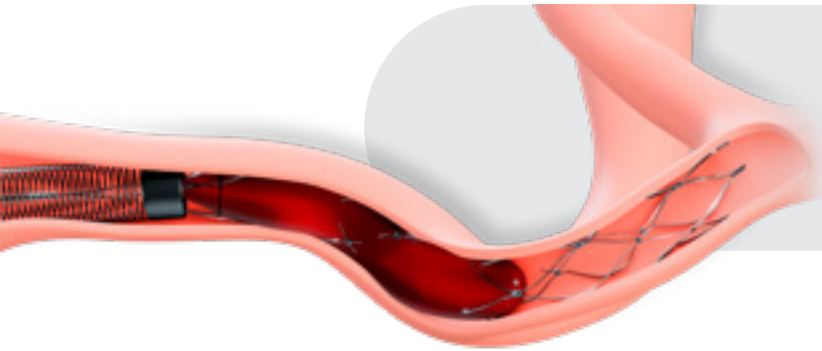

Excellent conformability

- The axial slit allows a high adaptability
- Closed cells ensure optimal apposition in the removal

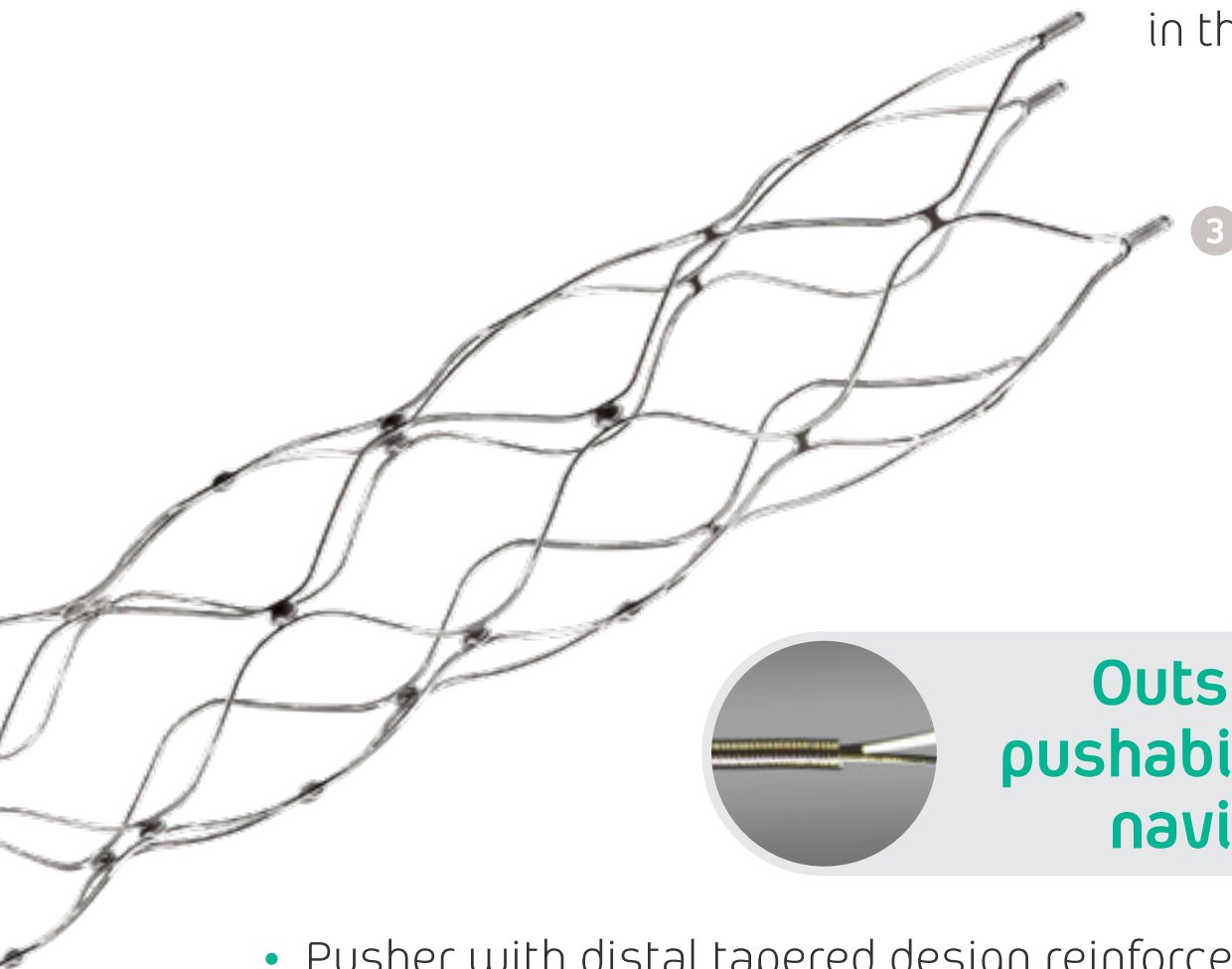

Outstanding pushability and navigability

- Pusher with distal tapered design reinforced by a coil
- Two pushers designed for the different vessels to be treated



iNtercept features

- > Self-expandable nitinol basket
- > Closed cells
- > Distal radiopaque markers:
Platinum coil → 2 markers in 3mm diameter and 3 markers in diameters 4 and 6mm
- > Central gold radiopaque markers along the basket

- > Proximal gold radiopaque marker at the junction of the pusher and the basket
- > Tapered pusher design at distal level reinforced by a stainless steel coil

Includes

- Torque device

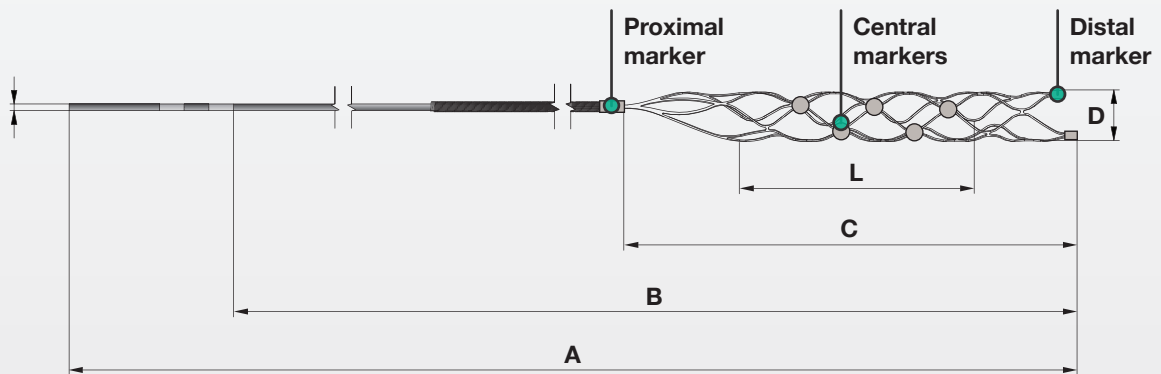

CE mark product. Certified by Notified Body 0318

iNtercept							
References	Nominal size					Microcatheter compatibility (inches)	Vessel to treat (maximum Ø) (mm)
	A (cm)	B (cm)	C (mm)	D (mm)	L (mm)		
DETNS195030015	195	152	28	3	15	0,017	2,5
DETNS195030020	195	152	32	3	20	0,017	2,5
DETNS195040020	195	152	33	4	20	0,021	3,5
DETNS195040030	195	152	42	4	30	0,021	3,5
DETNS195060030	195	153	53	6	30	0,021 / 0,027	5,5
DETNS195060050	195	155	69	6	50	0,021 / 0,027	5,5



The availability of each reference for sale is linked to the marketing authorisation in the country of destination

Distributed by:

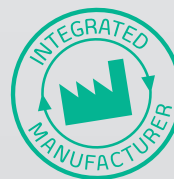
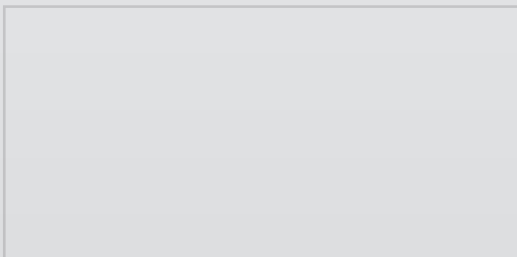

Manufactured by:

Life Vascular Devices Biotech S.L
www.ivascular.global
info@ivascular.global



iVascular[®]
therapies for living

xperience pro

Coronary balloon dilatation catheter



The balloon that crosses all lesions



www.ivascular.global

The latest balloon technology

Outstanding visibility

Metallic radiopaque markers with optimized crimping technology

0.024"*

The lowest
crossing profile

<3 seconds**

The fastest deflation time
even for big balloons due to
its optimized shaft design

xperience pro ensures the capacity to reach the most distal and complex lesions

1

Crossing all lesions due to a very low tip entry profile



0.016"

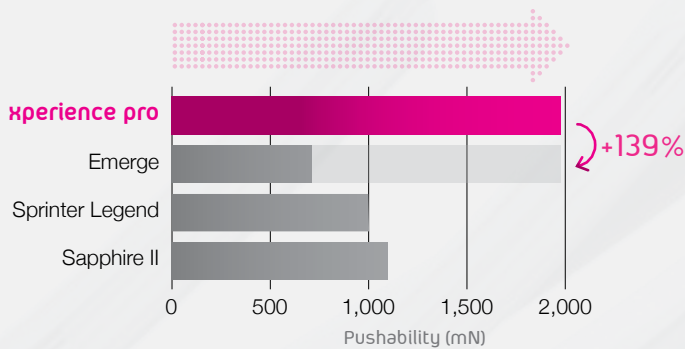

The highest pushability^{***}

Innovative material combination created with our proprietary technology makes the difference

2

3

Deliverability ensured by a new design with 2 distal shafts

2.6F | For small balloons ≤ 3mm

2.7F | For big balloons ≥ 3.25mm



HYDRAX



Proprietary formula

Optimal trackability due to our durable hydrophilic coating

4

xperience pro features

- > **Rapid Exchange** catheter (RX)
- > Compatible with **5F guiding catheter**
- > NP: **6 atm** | RBP: **16 atm**
- > **Semi-compliant:** 10-15%
- > **2 Pt/Ir metallic radiopaque markers**

Product with CE mark, certified by Notified Body 0318

Balloon diameter (mm)	Usable catheter length: 142 cm					
	Balloon length (mm)					
	10	15	20	25	30	40
1.25	BC PRI4N 150 125 010	BC PRI4N 150 125 015	BC PRI4N 150 125 020	-	-	-
	BC PRI4N 150 125 110 *	BC PRI4N 150 125 115 *	-	-	-	-
1.50	BC PRI4N 150 150 010	BC PRI4N 150 150 015	BC PRI4N 150 150 020	-	BC PRI4N 150 150 030	-
	BC PRI4N 150 150 110 *	BC PRI4N 150 150 115 *	-	-	-	-
2.00	BC PRI4N 150 200 010	BC PRI4N 150 200 015	BC PRI4N 150 200 020	BC PRI4N 150 200 025	BC PRI4N 150 200 030	BC PRI4N 150 200 040
2.25	BC PRI4N 150 225 010	BC PRI4N 150 225 015	BC PRI4N 150 225 020	BC PRI4N 150 225 025	BC PRI4N 150 225 030	BC PRI4N 150 225 040
2.50	BC PRI4N 150 250 010	BC PRI4N 150 250 015	BC PRI4N 150 250 020	BC PRI4N 150 250 025	BC PRI4N 150 250 030	BC PRI4N 150 250 040
2.75	BC PRI4N 150 275 010	BC PRI4N 150 275 015	BC PRI4N 150 275 020	BC PRI4N 150 275 025	BC PRI4N 150 275 030	BC PRI4N 150 275 040
3.00	BC PRI4N 150 300 010	BC PRI4N 150 300 015	BC PRI4N 150 300 020	BC PRI4N 150 300 025	BC PRI4N 150 300 030	BC PRI4N 150 300 040
3.25	BC PRI4N 150 325 010	BC PRI4N 150 325 015	BC PRI4N 150 325 020	BC PRI4N 150 325 025	BC PRI4N 150 325 030	BC PRI4N 150 325 040
3.50	BC PRI4N 150 350 010	BC PRI4N 150 350 015	BC PRI4N 150 350 020	BC PRI4N 150 350 025	BC PRI4N 150 350 030	BC PRI4N 150 350 040
3.75	BC PRI4N 150 375 010	BC PRI4N 150 375 015	BC PRI4N 150 375 020	BC PRI4N 150 375 025	BC PRI4N 150 375 030	BC PRI4N 150 375 040
4.00	BC PRI4N 150 400 010	BC PRI4N 150 400 015	BC PRI4N 150 400 020	BC PRI4N 150 400 025	BC PRI4N 150 400 030	BC PRI4N 150 400 040
4.50	BC PRI4N 150 450 010	BC PRI4N 150 450 015	BC PRI4N 150 450 020	BC PRI4N 150 450 025	BC PRI4N 150 450 030	BC PRI4N 150 450 040
5.00	BC PRI4N 150 500 010	BC PRI4N 150 500 015	BC PRI4N 150 500 020	-	-	-

The availability of each reference for the sale is linked to the authorization of commercialization in the country of destination
* Reference with one radiopaque marker centered in the balloon

Distributed by:

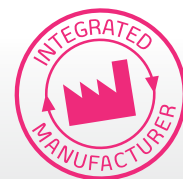

Manufactured by:

Life Vascular Devices Biotech S.L
www.ivascular.global
info@ivascular.global

NC xperience

Coronary balloon dilatation catheter

RBP up to 20 atm

Perfect for post-dilatation

The best tip profile
on the market

Ultra-low
crossing profile

to cross through stent struts
and calcified lesions

Outstanding
trackability

excellent pushability
and flexibility

HYDRAX



Hydrophilic
durable coating



Kissing balloon technique 6F compatible

The low transition profile between the hypotube and the distal shaft allows 6F kissing balloon technique



Indications:

- All types of dilatation even the most calcified lesions requiring high pressure inflations to improve myocardial perfusion
- Stent post dilatation to enhance stent artery wall apposition and improve angiographic results

NC xperience features

- > **Rapid Exchange** catheter (RX)
- > Compatible with **0.014"** guidewire
- > Compatible with **5F** guiding catheter
- > Nominal pressure: **12 atm** | ABP: **25 atm**
- > RBP: **20 atm** ($\varnothing < 4.50\text{mm}$) **18 atm** ($\varnothing \geq 4.50\text{mm}$)
- > Tip profile: **0.016"**
- > Balloon crossing profile: **from 0.029" up to 0.037"**
- > **2 metallic platinum iridium radiopaque markers**
- > **Compliance: 7% max**
- > **Deflation rate: 3s average**

Product with CE mark, certified by Notified Body 0318

Balloon diameter (mm)	Usable catheter length: 142 cm							
	Balloon length (mm)							
	6	8	10	12	15	20	25	30
2.00	BC TRI4 150 200 006	BC TRI4 150 200 008	BC TRI4 150 200 010	BC TRI4 150 200 012	BC TRI4 150 200 015	BC TRI4 150 200 020	BC TRI4 150 200 025	BC TRI4 150 200 030
2.25	BC TRI4 150 225 006	BC TRI4 150 225 008	BC TRI4 150 225 010	BC TRI4 150 225 012	BC TRI4 150 225 015	BC TRI4 150 225 020	BC TRI4 150 225 025	BC TRI4 150 225 030
2.50	BC TRI4 150 250 006	BC TRI4 150 250 008	BC TRI4 150 250 010	BC TRI4 150 250 012	BC TRI4 150 250 015	BC TRI4 150 250 020	BC TRI4 150 250 025	BC TRI4 150 250 030
2.75	BC TRI4 150 275 006	BC TRI4 150 275 008	BC TRI4 150 275 010	BC TRI4 150 275 012	BC TRI4 150 275 015	BC TRI4 150 275 020	BC TRI4 150 275 025	BC TRI4 150 275 030
3.00	BC TRI4 150 300 006	BC TRI4 150 300 008	BC TRI4 150 300 010	BC TRI4 150 300 012	BC TRI4 150 300 015	BC TRI4 150 300 020	BC TRI4 150 300 025	BC TRI4 150 300 030
3.25	BC TRI4 150 325 006	BC TRI4 150 325 008	BC TRI4 150 325 010	BC TRI4 150 325 012	BC TRI4 150 325 015	BC TRI4 150 325 020	BC TRI4 150 325 025	BC TRI4 150 325 030
3.50	BC TRI4 150 350 006	BC TRI4 150 350 008	BC TRI4 150 350 010	BC TRI4 150 350 012	BC TRI4 150 350 015	BC TRI4 150 350 020	BC TRI4 150 350 025	BC TRI4 150 350 030
3.75	BC TRI4 150 375 006	BC TRI4 150 375 008	BC TRI4 150 375 010	BC TRI4 150 375 012	BC TRI4 150 375 015	BC TRI4 150 375 020	BC TRI4 150 375 025	BC TRI4 150 375 030
4.00	BC TRI4 150 400 006	BC TRI4 150 400 008	BC TRI4 150 400 010	BC TRI4 150 400 012	BC TRI4 150 400 015	BC TRI4 150 400 020	BC TRI4 150 400 025	BC TRI4 150 400 030
4.50	BC TRI4 150 450 006	BC TRI4 150 450 008	BC TRI4 150 450 010	BC TRI4 150 450 012	BC TRI4 150 450 015	BC TRI4 150 450 020		
5.00	BC TRI4 150 500 006	BC TRI4 150 500 008	BC TRI4 150 500 010	BC TRI4 150 500 012	BC TRI4 150 500 015	BC TRI4 150 500 020		

The availability of each reference for the sale is linked to the authorization of commercialization in the country of destination

Distributed by:

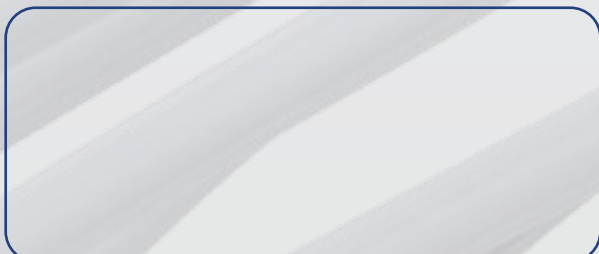

Manufactured by:

Life Vascular Devices Biotech S.L
www.ivascular.global
info@ivascular.global

iVascular[®]
therapies for living

iVolution pro

Self-expanding peripheral stent system

Quality as first option

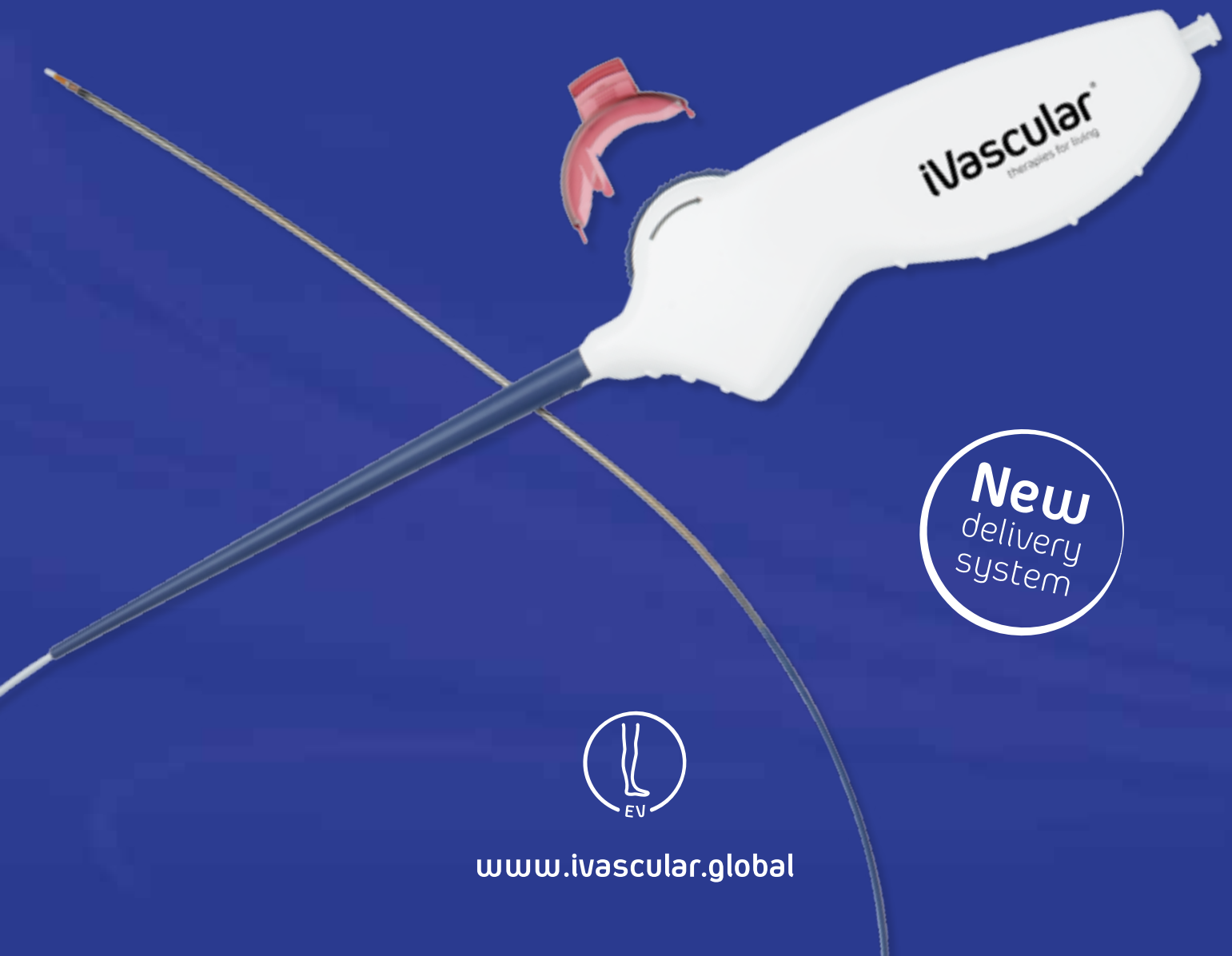

New
delivery
system



www.ivascular.global

New delivery

Simple and controlled stent deployment

No jumping effect

Optimum visibility

- 2 markers delimiting the stent
- 1 tungsten marker in the retractable sheath indicating the implantation level

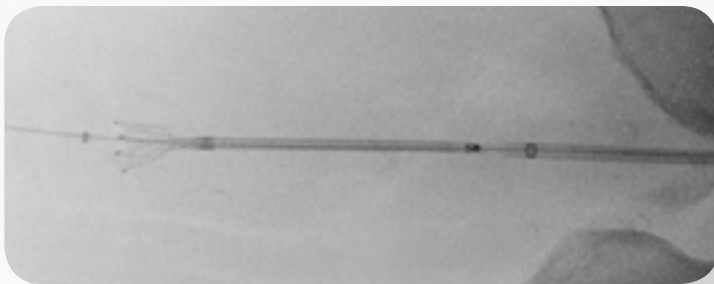

Triple sheath design

to control deployment forces and facilitate precise placement

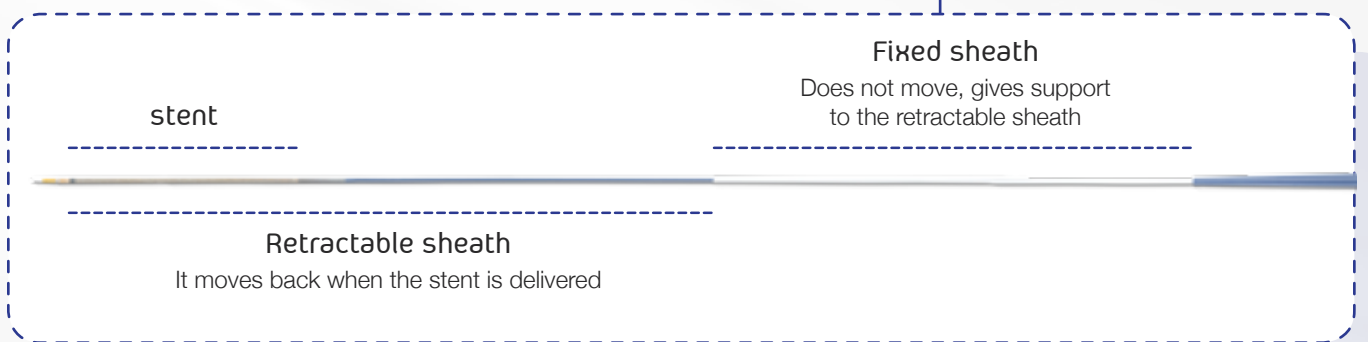

*iVascular internal data

ery system

Controlled deployment

The deployment speed can be modulated with the wheel

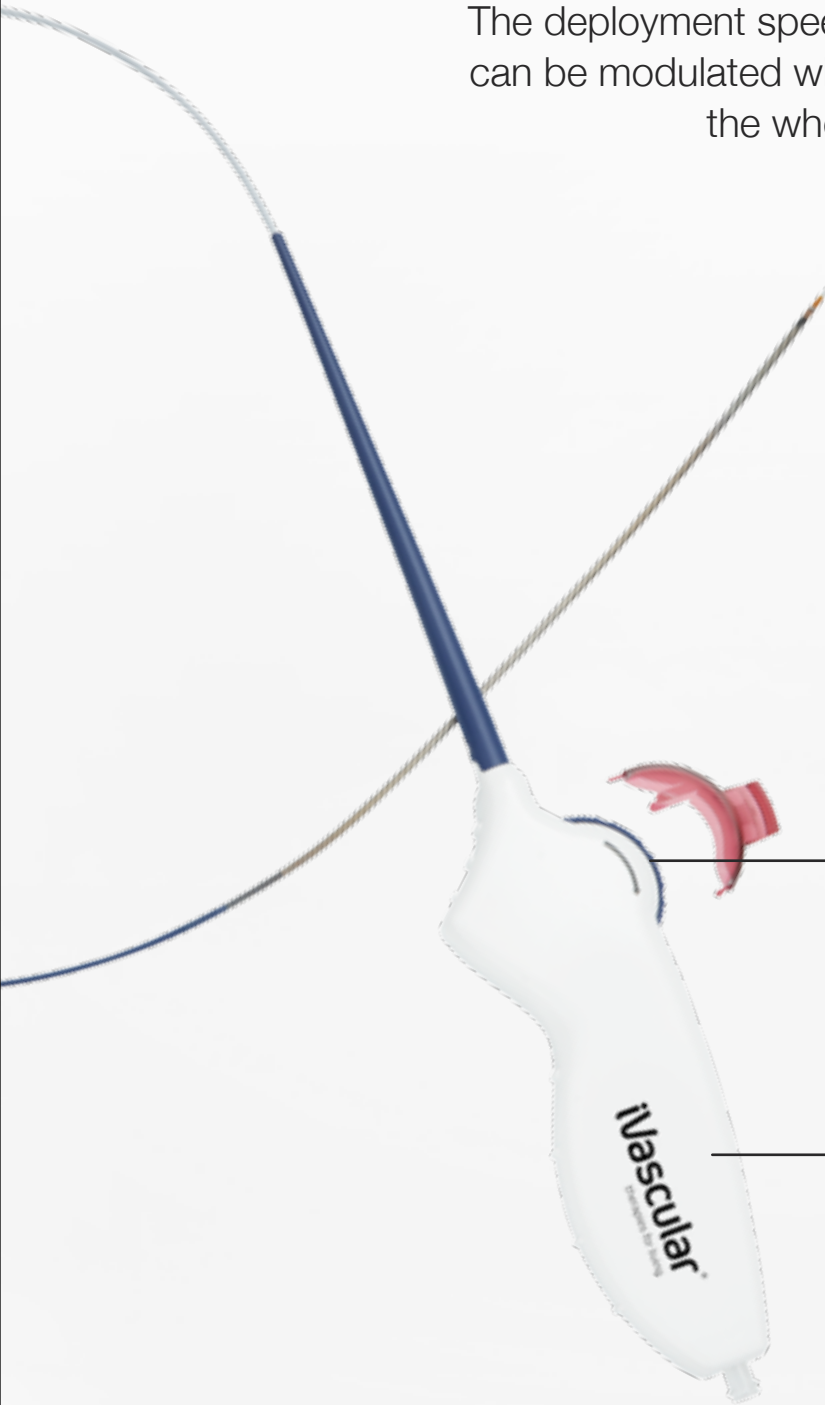

Ergonomic and small handle

10cm shorter than main competitors*

Stent quality

Quality assured to avoid stent fracture

100% of stents checked



No reported stent fractures in the EVOLUTION trial at 1-year¹

Best corrosion resistance and **lowest inclusion fraction** reported²

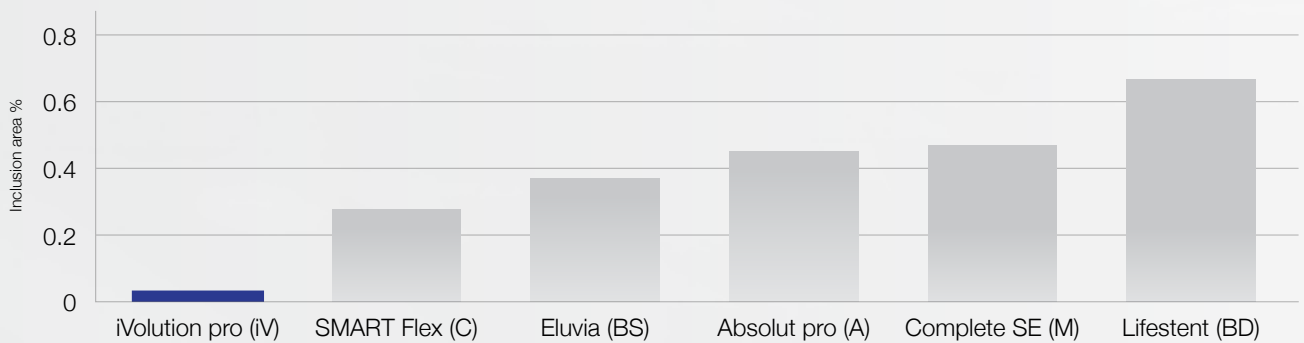

Inclusions are small particles inside the nitinol matrix. They are known as a fatigue starting points

Highest elastic recovery & minimum brittleness

Hydrogen in stent can suppress elastic recovery and promote brittleness. iVolution pro is the stent with lowest hydrogen content³

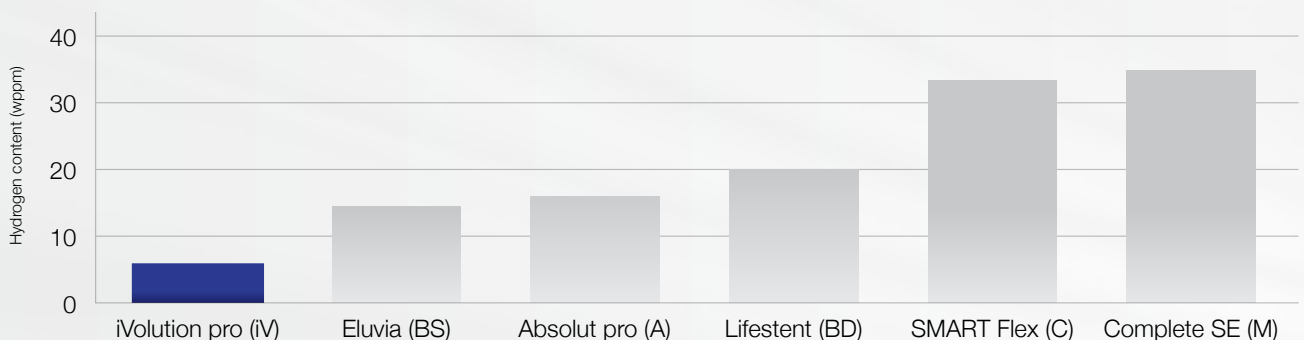

¹ M Bosiers et al. EVOLUTION Study: 12-month results. 2019 Aug;60(4):490-495.

² F Sun et al. On the High Sensitivity of Corrosion Resistance of NiTi Stents with Respect to Inclusions: An Experimental Evidence, ACS Omega, 2020

³ F Sun et al. Revisiting the effects of low-concentration hydrogen in NiTi self-expandable stents. Materials Science & Engineering C 118 (2021) 111405

Stent design

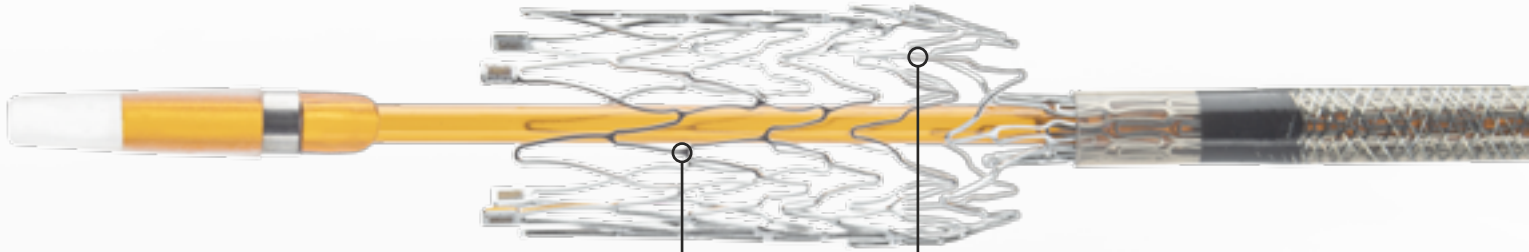

Resistance

Stress homogeneously distributed to avoid stent fracture

Flexibility

Open cell design to offer the highest flexibility

Visibility

4 tantalum markers at each end

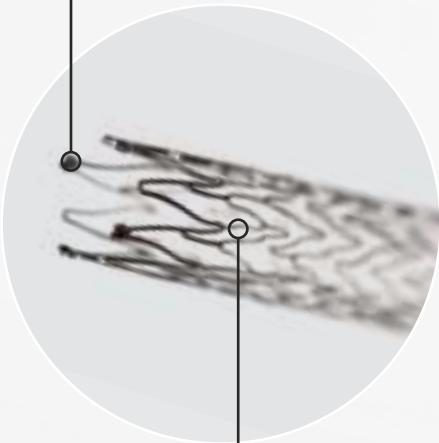

No jumping effect

Closed cell design ends for deployment stability

No flaking

Avoids vessel wall damage



Anti-kinking

Maintains inner lumen

Clinical e

Highest efficacy outcomes

EVOLUTION Trial¹

- Physician-initiated, prospective, and multicentric trial, investigating the efficacy of iVolution
- PI: Dr Marc Bosiers
- N:120 patients
- Symptomatic (Rutherford 2-4) femoropopliteal arterial stenotic or occlusive lesions.
- Follow-up: 1 year

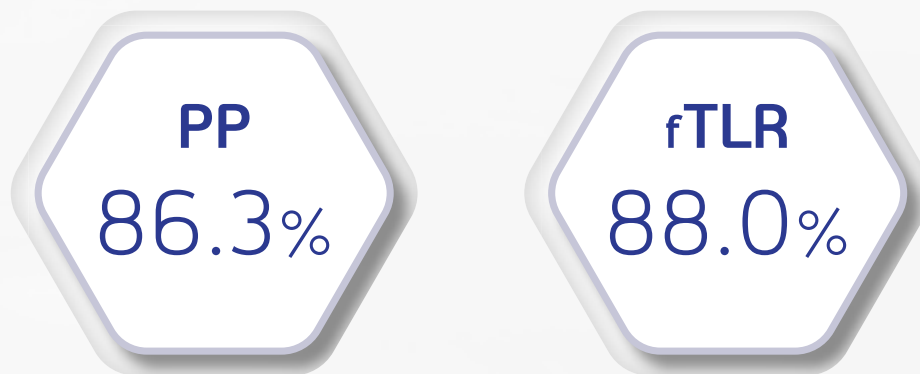

Primary patency comparison

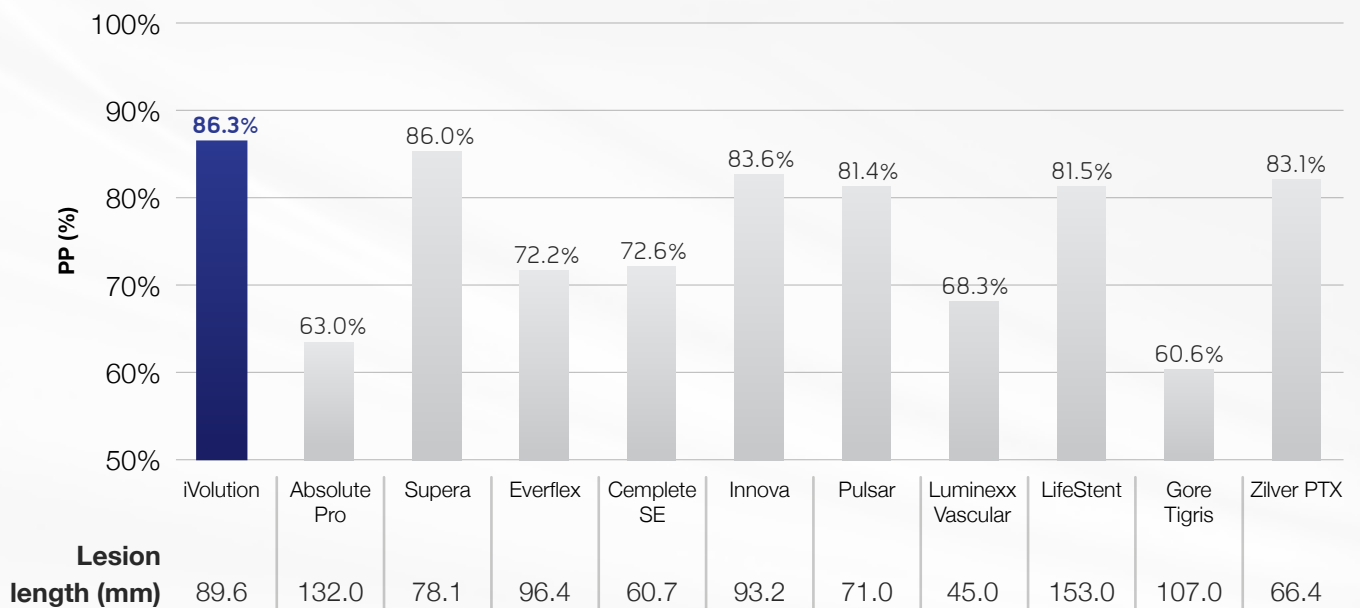

evidence

in femoropopliteal arteries

TINTIN Trial (1-year follow-up)²

- Physician initiated, prospective, multi-center trial, investigating the safety and efficacy of the treatment with Luminor and iVolution
- PI: Dr Koen Deloose
- N: 100 patients
- TASC C and D femoropopliteal atherosclerotic lesions
- Follow-up: 1, 2, 3, 4 and 5 years



Comparison of main lesion length vs PP at 1-year follow up between 26 trials

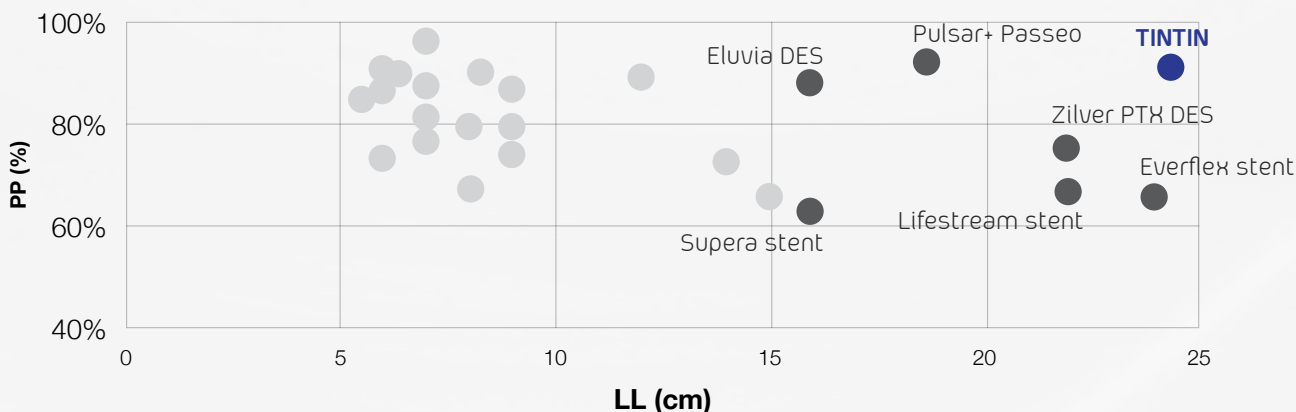

¹ M Bosiers et al. EVOLUTION Study: 12-month results. 2019 Aug;60(4):490-495. ² K Deloose. LINC 2020 presentation

iVolution pro features

- > **Triple sheath** catheter
- > Catheter length: **80** and **130** cm
- > Introducer compatibility: **6F**
- > Guiding catheter compatibility: **8F**
- > Portfolio:
 - Ø: 5-10mm
 - Length: 40-200mm
- > Guidewire compatibility: **0.035"**

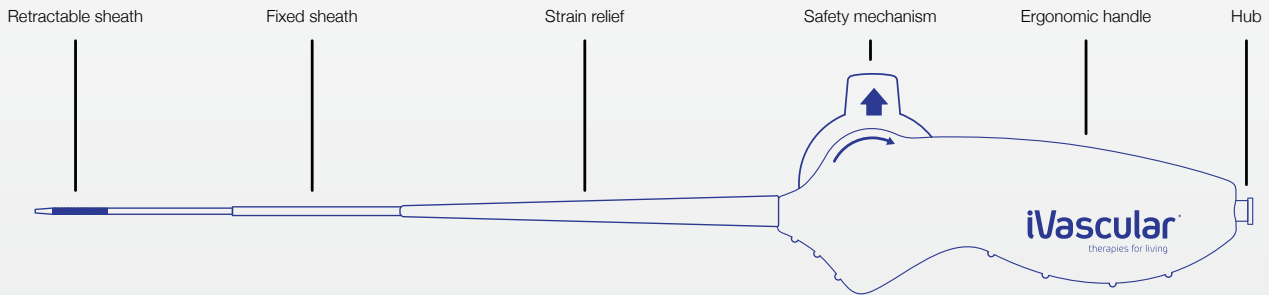

Product with CE mark, certified by Notified Body 0318

Usable catheter length (cm)	Stent Diameter (mm)	Stent length (mm)					
		40	60	80	100	150	200
80	5	SPNBC35N080050040	SPNBC35N080050060	SPNBC35N080050080	SPNBC35N080050100	SPNBC35N080050150	SPNBC35N080050200
	6	SPNBC35N080060040	SPNBC35N080060060	SPNBC35N080060080	SPNBC35N080060100	SPNBC35N080060150	SPNBC35N080060200
	7	SPNBC35N080070040	SPNBC35N080070060	SPNBC35N080070080	SPNBC35N080070100	SPNBC35N080070150	SPNBC35N080070200
	8	SPNBC35N080080040	SPNBC35N080080060	SPNBC35N080080080	SPNBC35N080080100	SPNBC35N080080150	-
	9	SPNBC35N080090040	SPNBC35N080090060	SPNBC35N080090080	SPNBC35N080090100	-	-
	10	SPNBC35N080100040	SPNBC35N080100060	SPNBC35N080100080	SPNBC35N080100100	-	-
130	5	SPNBC35N130050040	SPNBC35N130050060	SPNBC35N130050080	SPNBC35N130050100	SPNBC35N130050150	SPNBC35N130050200
	6	SPNBC35N130060040	SPNBC35N130060060	SPNBC35N130060080	SPNBC35N130060100	SPNBC35N130060150	SPNBC35N130060200
	7	SPNBC35N130070040	SPNBC35N130070060	SPNBC35N130070080	SPNBC35N130070100	SPNBC35N130070150	SPNBC35N130070200
	8	SPNBC35N130080040	SPNBC35N130080060	SPNBC35N130080080	SPNBC35N130080100	SPNBC35N130080150	-
	9	SPNBC35N130090040	SPNBC35N130090060	SPNBC35N130090080	SPNBC35N130090100	-	-
	10	SPNBC35N130100040	SPNBC35N130100060	SPNBC35N130100080	SPNBC35N130100100	-	-

The availability of each reference for the sale is linked to the authorization of commercialization in the country of destination

Introducer compatibility: **6F**

Distributed by:



Manufactured by:

Life Vascular Devices Biotech S.L
www.ivascular.global
info@ivascular.global



iVascular[®]
therapies for living

i0
years

essential pro

Paclitaxel eluting coronary balloon dilatation catheter



The novel reliable DCB



www.ivascular.global

essential pro

the novel reliable DCB



Outstanding visibility with metallic radiopaque markers



Fast deflation time due to an optimized design

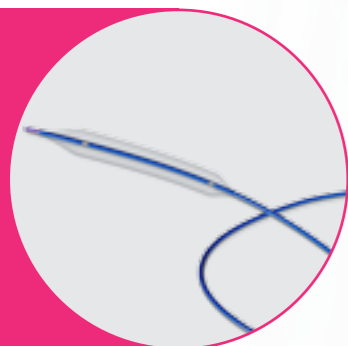

Optimal navigation due to the innovative combination of materials and proprietary hydrophilic coating *hydrax plus*

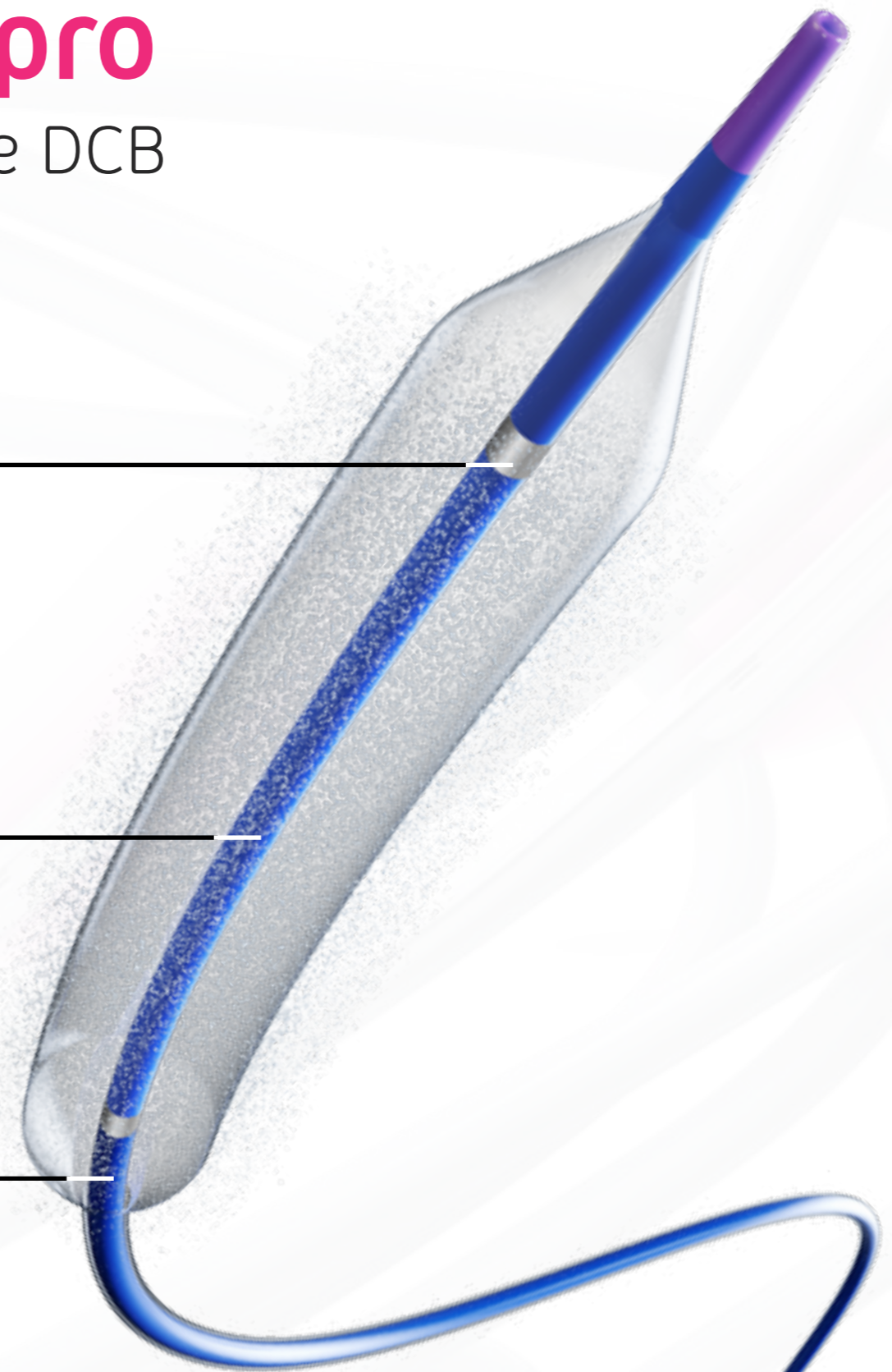

The latest balloon design

Clinical benefits

Low drug loss during navigation
Low stress on the coating
Homogeneous distribution drug

SAFETY

EFFECTIVENESS

Fast absorption and transfer
 High retention time improving **quality of healing**

The 3rd DCB generation

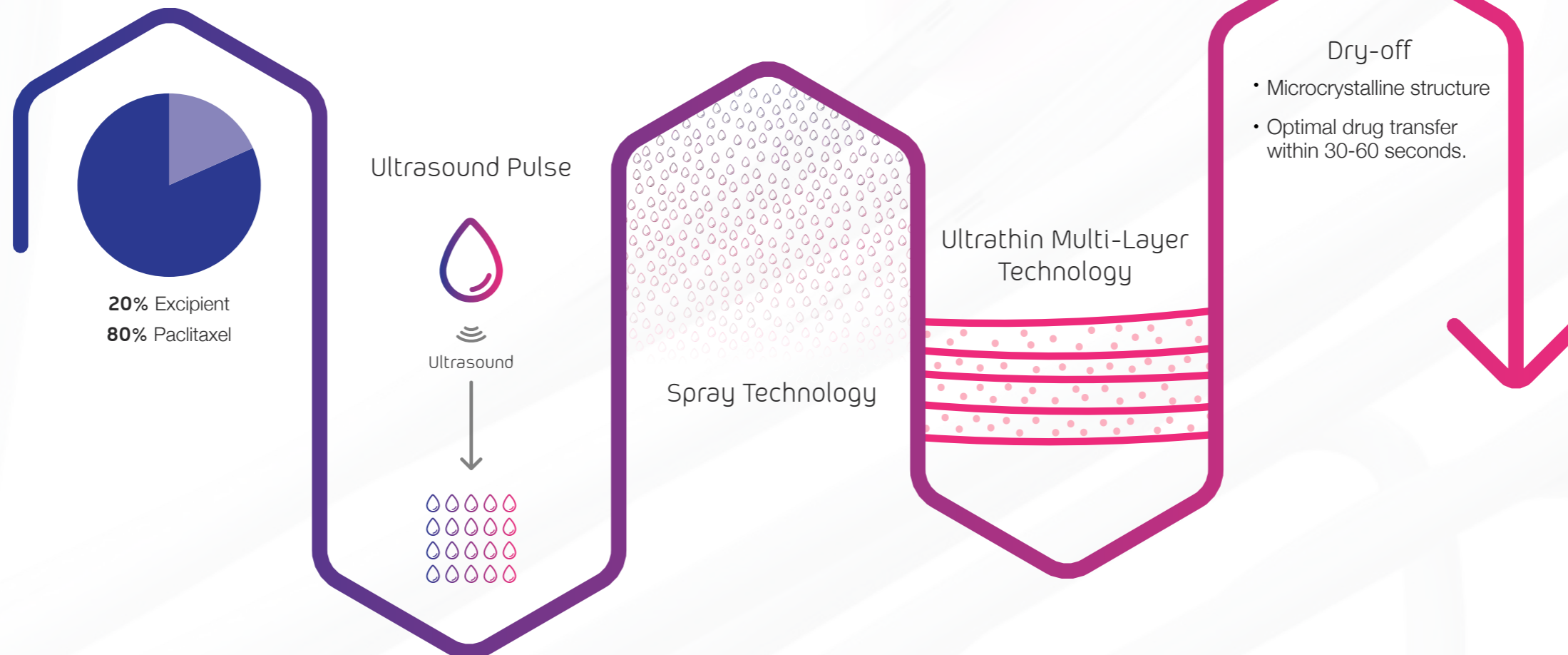

iVasTriam

The iVascular Clinical Trial Program

essential in small vessels*

Observational, prospective and multicenter registry in small vessels.



Very small diameter of reference (<2.5mm) and high risk patients (56% diabetics) with only a 12.7% of bailout stenting



TLF at 12-month as a primary endpoint



MACE at 12-month as a secondary endpoint

The RELIABLE ALTERNATIVE for small coronary vessels

essential in stent restenosis**

Investigator initiated, observational, prospective and multicenter study.



DES restenosis was treated in 67% of the cases and a 94% of DCB angiographic success was achieved with only 2 additional stenting



In-segment maximal area stenosis at 6-month as a primary endpoint



TLF at 24-month as a secondary endpoint

GOOD and SUSTAINED EFICACCY for treatment of ISR

* n = 71
Registry published in Sept. 2018:
Rodés-Cabau J. et. Al. Coronary Artery Disease. 29(6): 477-481, Sept. 2018

** n = 33
Study published in July 2019
De la Torre et al. Cardiovascular Revascularization Medicine July 2019, in press

essential pro features

- > **Rapid exchange catheter (RX)**
- > Guide wire compatibility: **max. 0.014"**
- > **2 distal shafts:** 2.6F ($\varnothing \leq 3$), 2.7F ($\varnothing \geq 3.25$)
- > NP: **6 atm** | RBP: **16 atm**
- > **2 Pt/Ir radiopaque markers**
- > **hydrophilic coating hydrax plus**

Product with CE mark, certified by Notified Body 0318

Balloon diameter (mm)	Working catheter length: 142 cm					
	Balloon length (mm)					
	10	15	20	25	30	40
1.50	BC DPRI4N 150 150 010	BC DPRI4N 150 150 015	BC DPRI4N 150 150 020	-	BC DPRI4N 150 150 030	-
2.00	BC DPRI4N 150 200 010	BC DPRI4N 150 200 015	BC DPRI4N 150 200 020	BC DPRI4N 150 200 025	BC DPRI4N 150 200 030	BC DPRI4N 150 200 040
2.25	BC DPRI4N 150 225 010	BC DPRI4N 150 225 015	BC DPRI4N 150 225 020	BC DPRI4N 150 225 025	BC DPRI4N 150 225 030	BC DPRI4N 150 225 040
2.50	BC DPRI4N 150 250 010	BC DPRI4N 150 250 015	BC DPRI4N 150 250 020	BC DPRI4N 150 250 025	BC DPRI4N 150 250 030	BC DPRI4N 150 250 040
2.75	BC DPRI4N 150 275 010	BC DPRI4N 150 275 015	BC DPRI4N 150 275 020	BC DPRI4N 150 275 025	BC DPRI4N 150 275 030	BC DPRI4N 150 275 040
3.00	BC DPRI4N 150 300 010	BC DPRI4N 150 300 015	BC DPRI4N 150 300 020	BC DPRI4N 150 300 025	BC DPRI4N 150 300 030	BC DPRI4N 150 300 040
3.25	BC DPRI4N 150 325 010	BC DPRI4N 150 325 015	BC DPRI4N 150 325 020	BC DPRI4N 150 325 025	BC DPRI4N 150 325 030	BC DPRI4N 150 325 040
3.50	BC DPRI4N 150 350 010	BC DPRI4N 150 350 015	BC DPRI4N 150 350 020	BC DPRI4N 150 350 025	BC DPRI4N 150 350 030	BC DPRI4N 150 350 040
3.75	BC DPRI4N 150 375 010	BC DPRI4N 150 375 015	BC DPRI4N 150 375 020	BC DPRI4N 150 375 025	BC DPRI4N 150 375 030	BC DPRI4N 150 375 040
4.00	BC DPRI4N 150 400 010	BC DPRI4N 150 400 015	BC DPRI4N 150 400 020	BC DPRI4N 150 400 025	BC DPRI4N 150 400 030	BC DPRI4N 150 400 040
4.50	BC DPRI4N 150 450 010	BC DPRI4N 150 450 015	BC DPRI4N 150 450 020	BC DPRI4N 150 450 025	BC DPRI4N 150 450 030	BC DPRI4N 150 450 040

The availability of each reference for the sale is linked to the authorization of commercialization in the country of destination

Distributed by:

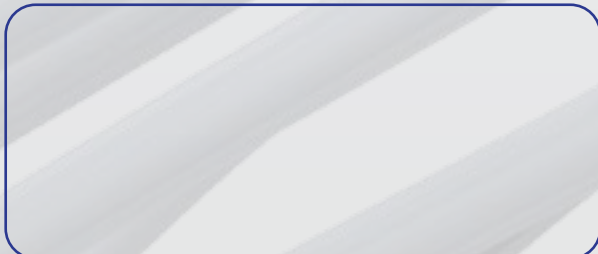

Manufactured by:

Life Vascular Devices Biotech S.L
www.ivascular.global
info@ivascular.global

iCover

Peripheral balloon expandable
PTFE covered stent system

Designed to
cover all needs



www.ivascular.global

iVascular[®]
therapies for living

Able to treat the most tortuous arteries

iCover

Designed to cover all needs

Enhanced visibility

Unique stent with radiopaque markers to facilitate the implantation and the post-dilation

ePTFE covered stent with high flexibility

Due to:

- Open cell design and alternated links
- Nested peaks to avoid strut-to-strut contact

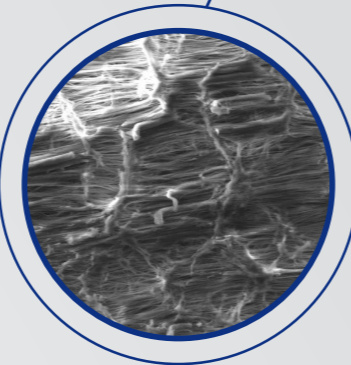
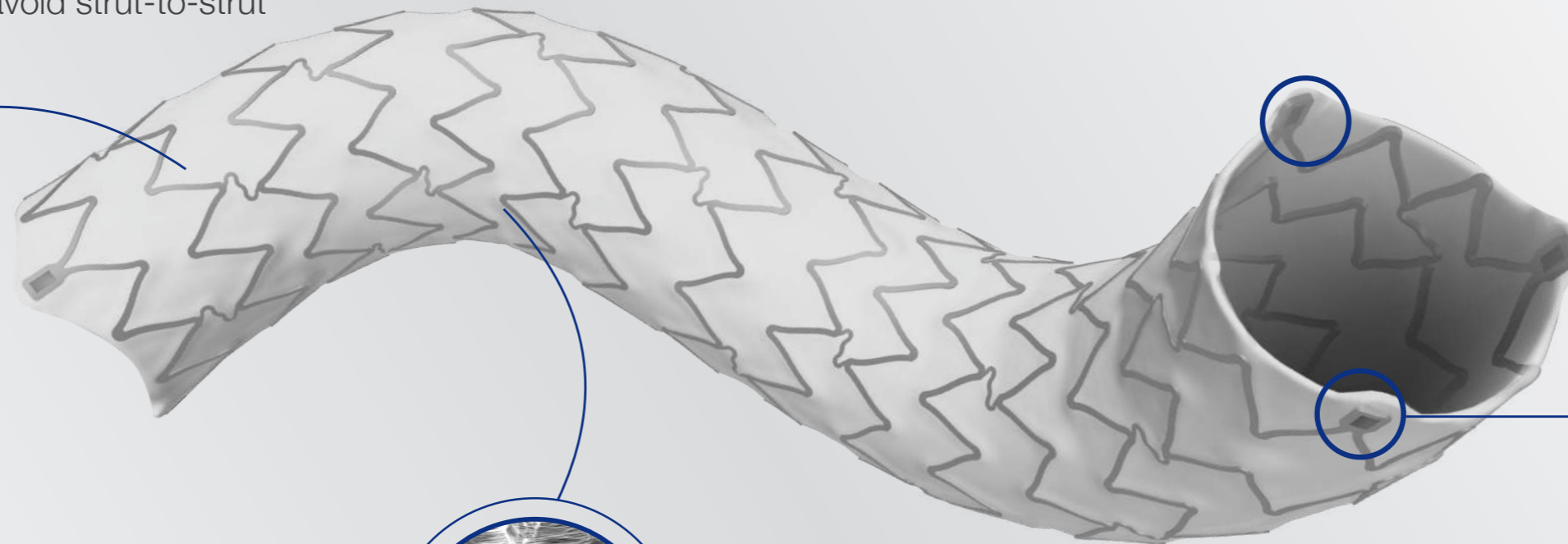

Best in class post-expansion capacity ($\geq 2\text{mm}$)

High ePTFE porosity to ensure covered stent post-expansion capacity



STENT DIMENSIONS		MAXIMUM POST-EXPANSION DIAMETERS						
		STENT DIAMETERS (mm)						
		5	6	7	8	9	10	
STENT LENGTH (mm)	17	$\leq 10\text{mm}$					$\leq 12\text{mm}$	
	27							
	37							
	57							

Excellent navigability and easy to implant

iCover
Designed to cover all needs

Outstanding flexibility

of the crimped stent, avoiding the kinking during navigation

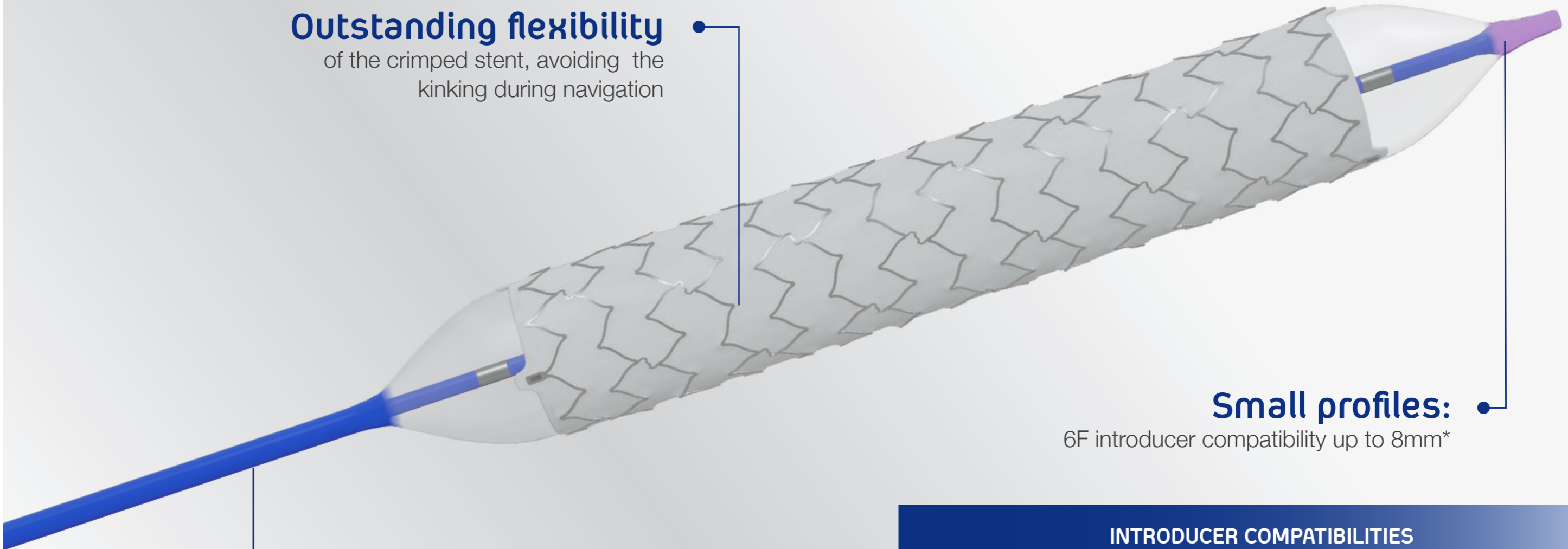

Small profiles:

6F introducer compatibility up to 8mm*

Crimped on an Oceanus 35 PTA balloon, offering:

- Short deflation times
- Good pushability and trackability

INTRODUCER COMPATIBILITIES

STENT DIMENSIONS		STENT DIAMETERS (mm)					
		5	6	7	8	9	10
STENT LENGTH (mm)	17	6F				7F	
	27						
	37						
	57						

* 6F up to 8x17 mm and 7F from 8x27mm up to 10 mm.

iVascular proprietary encapsulation technology

iCover
Designed to cover all needs

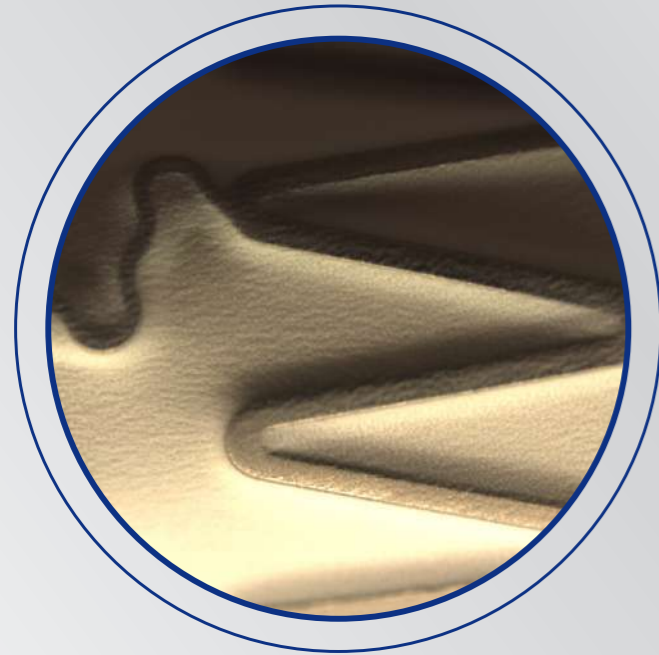

Encapsulation technology

iCover is a stent completely encapsulated with 2 ePTFE layers



Specific ePTFE laser cutting technology

• Perfect sealing

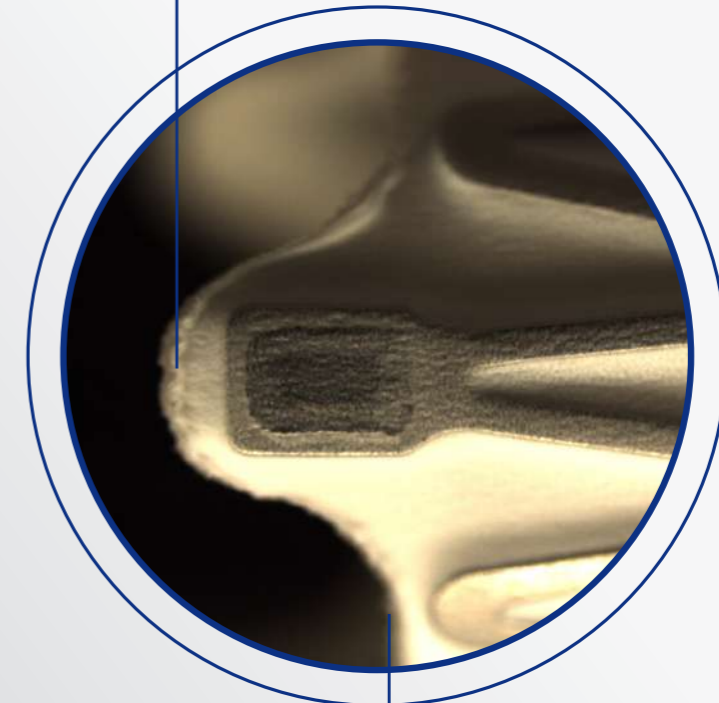

The laser follows the stent outline while cutting the contour



Proprietary technology to encapsulate the stent into an inner and outer ePTFE layer

Ensures complete encapsulation avoiding delamination

iCover features

- > Over the wire catheter (OTW)
- > Guidewire compatibility: **0.035"**
- > Catheter length: **80** and **140** cm
- > NP: 9 atm
- > RBP:
 - Ø 5-7mm: 15 atm
 - Ø 8mm: 14 atm
 - Ø 9-10mm: 13 atm
- > Maximum post-expansion:
 - Ø 5-8mm: ≤10mm
 - Ø 9-10mm: ≤ 12mm
- > CoverTech encapsulation technology
- > Introducer compatibility
6F (up to Ø8mm, L 17mm), **7F** (≥8mmØ, L27mm)
- > **3 radiopaque markers** at each stent end
- > Stent material: CoCr L605
- > Graft material: ePTFE
- > Recoil: ≤ 10 %
- > Shortening:
 - Length 17mm: ≤ 12 %
 - Length 57mm: ≤ 8 %

Product with CE mark, certified by Notified Body 0318

Effective catheter length (cm)	Stent diameter (mm)	Stent length (mm)			
		17	27	37	57
80	5	SPCBCC35080050017	SPCBCC35080050027	SPCBCC35080050037	SPCBCC35080050057
	6	SPCBCC35080060017	SPCBCC35080060027	SPCBCC35080060037	SPCBCC35080060057
	7	SPCBCC35080070017	SPCBCC35080070027	SPCBCC35080070037	SPCBCC35080070057
	8	SPCBCC35080080017	SPCBCC35080080027	SPCBCC35080080037	SPCBCC35080080057
	9		SPCBCC35080090027	SPCBCC35080090037	SPCBCC35080090057
	10		SPCBCC35080100027	SPCBCC35080100037	SPCBCC35080100057
140	5	SPCBCC35140050017	SPCBCC35140050027	SPCBCC35140050037	SPCBCC35140050057
	6	SPCBCC35140060017	SPCBCC35140060027	SPCBCC35140060037	SPCBCC35140060057
	7	SPCBCC35140070017	SPCBCC35140070027	SPCBCC35140070037	SPCBCC35140070057
	8	SPCBCC35140080017	SPCBCC35140080027	SPCBCC35140080037	SPCBCC35140080057
	9		SPCBCC35140090027	SPCBCC35140090037	SPCBCC35140090057
	10		SPCBCC35140100027	SPCBCC35140100037	SPCBCC35140100057

- Introducer compatibility: **6F**
- Introducer compatibility: **7F**

Distributed by:

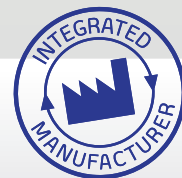

Manufactured by:
Life Vascular Devices Biotech, S.L
www.ivascular.global
info@ivascular.global

iVascular[®]
therapies for living

navitian

Coronary microcatheter



The navigation you need



www.ivascular.global

Navitian, the needed microcatheter to arrive to the most challenging lesions.

Its exceptional design brings benefits as:

Outstanding trackability through the small and tortuous arteries due to hydrophilic coating
HYDRAX PLUS

Optimal flexibility, pushability and resistance to kinking provided by a full length variable braided pattern

Complete guidewire control ensured by its conical transition

Superior crossability and penetration capacity due to its optimized tip profile and shape with a double c-cut radiopaque marker

navitian features

- > **Over the wire catheter (OTW)**
- > **Guidewire compatibility 0.014"**
- > **Usable catheter length 135 and 150 cm**
- > **1 double radiopaque marker**
- > **Internal PTFE layer**
- > **Hydrophilic coating: 70 and 90 cm**

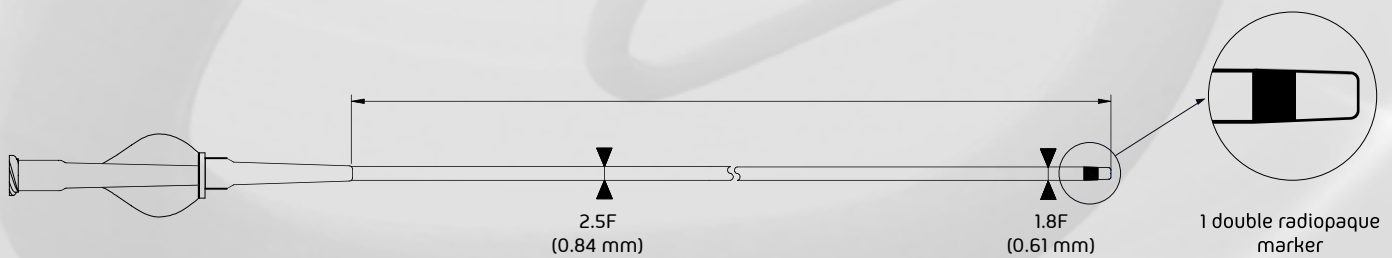

Product with CE mark, certified by Notified Body 0318

References

Usable length 135 cm

MCC C14 135 001

Usable length 150 cm

MCC C14 150 001

The availability of each reference for the sale is linked to the authorization of commercialization in the country of destination

Distributed by:



Manufactured by:

Life Vascular Devices Biotech S.L
www.ivascular.global
info@ivascular.global

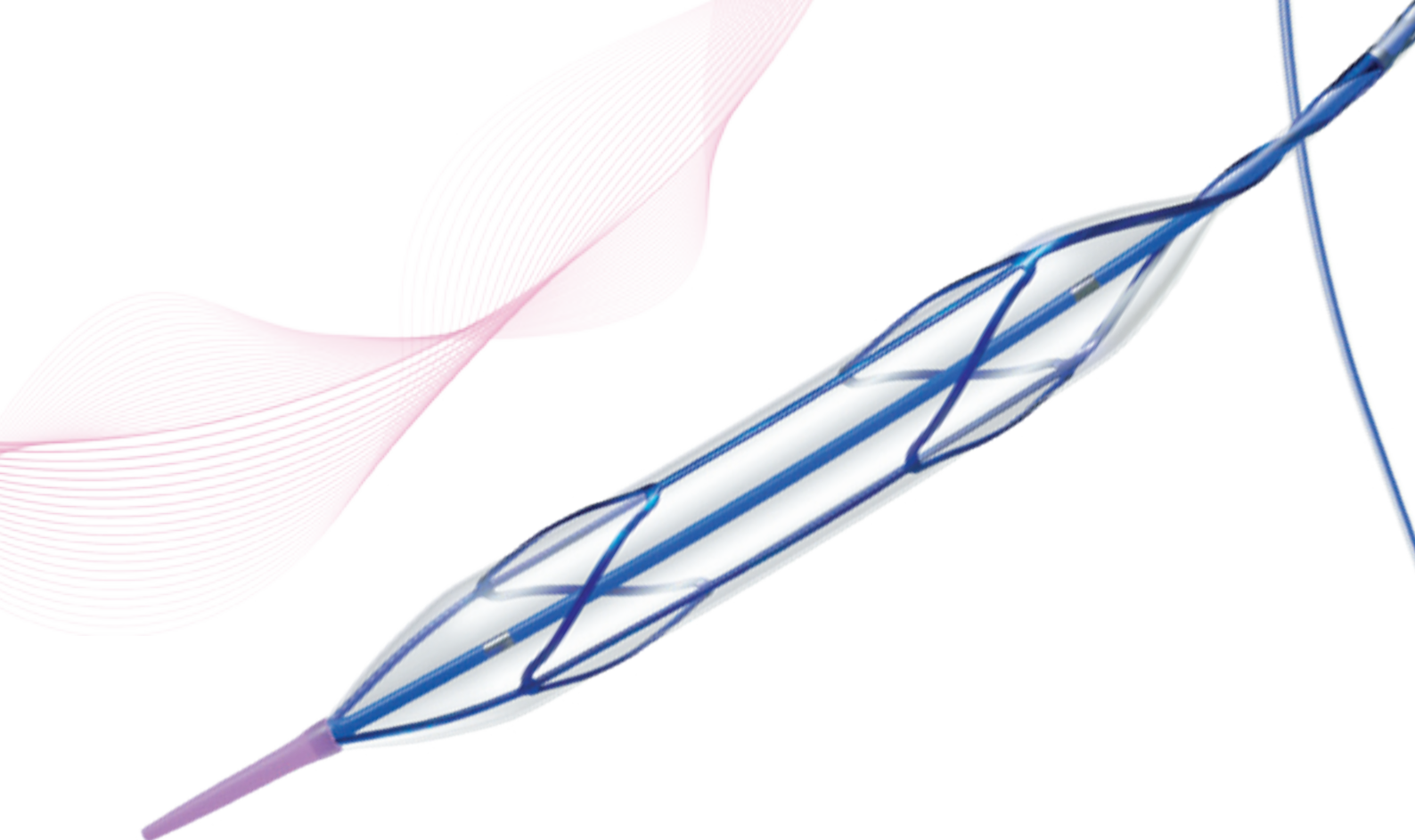

naviscore

Coronary scoring balloon dilatation
catheter



iVascular[®]
therapies for living

naviscore

A new player in calcified lesions

Naviscore is an **innovative coronary scoring balloon dilatation catheter**. iVascular breaks new ground by developing a product with a **hybrid design** that combines the benefits of scoring and cutting balloons.

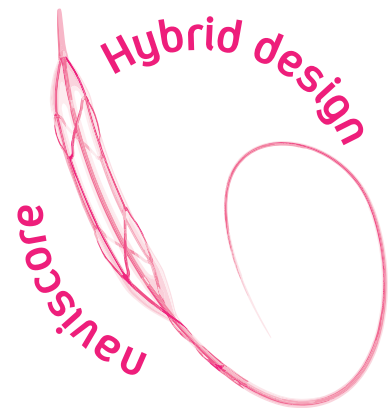

BEST OF CUTTING

Axial filaments orientation:

Ensures greater cross capacity and a 90° axial plaque modification.

BEST OF SCORING

Nitinol wires flexibility:

Ensures better navigability and low perforation risk while modifying the plaque.

When to use Naviscore

Naviscore is indicated in significant lesions, including in-stent restenosis and especially in complex lesions with:



Long length



Severe calcification



Significant bifurcation



Why Naviscore



Optimal trackability

Naviscore easily crosses the lesion

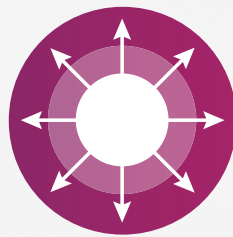

Enhanced scoring capacity

Naviscore performs an effective plaque modification



Excellent rewrap and recross capabilities

Naviscore inflates as many times as you need



Low profiles and no deformation ensured by axial structure.

Low artery wall friction due to proprietary hydrophilic coating.

The smallest diameter available in the market.



Ø1.50 mm

6 times larger scoring surface than competitor*.

21x more force than conventional balloons**. Uniform axial force at 90° offers more control on plaque modification.

20 atm of RBP. High-resistant semi-compliant balloon.

Excellent balloon folding due to its memory shape nitinol structure.

Optimized profile rewapping thanks to unique scoring structure.

* Data on file, comparison vs Angiosculpt, Phillips

** Data on file at iVascular. Naviscore vs semi-compliant balloon

Severely calcified lesion treated with Naviscore

Patient profile

- Male, 76 years old
- CRF: HTA, Ex-smoker, CKD
- NSTEMI 2018. BAV.

Lesion type

- Angiography showing the LCx chronically occluded, severely calcified.
- Also the LAD have a severe plaque and extremely calcified.

Procedure

- During the procedure a 6F guiding catheter was used.
- The lesion observed was severely calcified but **Naviscore 3.0 x 6mm could advance without difficulties** (Figure 1).
- **Naviscore crossed the calcified plaque easily** (Figure 2).
- Once **Naviscore crossed the lesion at the 1st attempt** (Figure 3), it was inflated progressively.
- First inflation was up to 18 atm, a deformity was noted on the proximal part.
- **On a second inflation, the balloon was inflated up to 20atm. The plaque broke and the vessel was opened with an optimal result.**
- Finally, an Angiolite stent was implanted. **Angiolite expanded and apposed correctly** showing an optimal angiographic result (Figure 6).

CRF: Cardiovascular risk factors, HTA: hypertension, CKD: Cronical kidney disease, NSTEMI: non-ST segment elevation myocardial infarction



Fig 1. LCx chronically occluded and LAD severely calcified

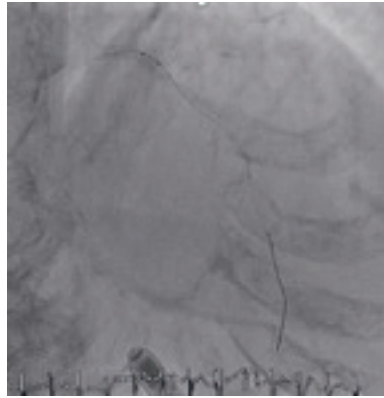

Fig 2. Naviscore penetrating the lesion at 1st attempt

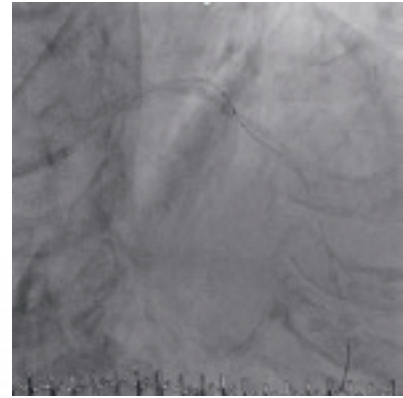

Fig 3. Naviscore crossed the lesion

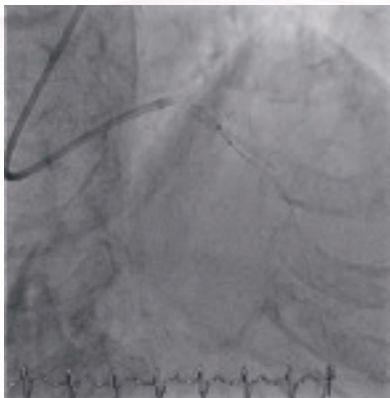

Fig 4. Naviscore inflated breaking the plaque

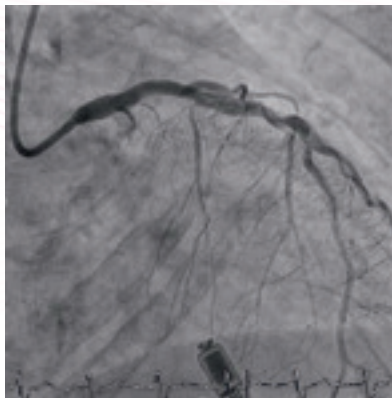

Fig 5. Angiographic result after Naviscore

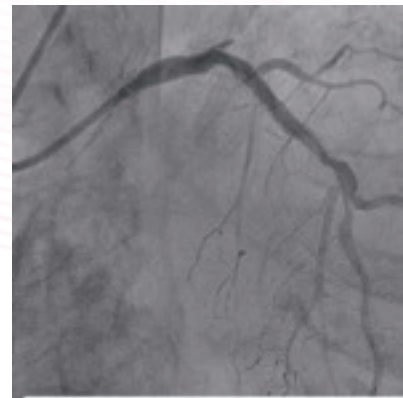

Fig 6. Final angiographic result

Conclusions

“Naviscore is a very powerful device with more pushability than the other competitors, easier entry into the lesions, and greater plaque modification.”

Naviscore should be the FIRST CHOICE DEVICE for the treatment of these difficult and complex lesions thanks to its crossing capacity of severely calcified lesions at the 1st attempt and the effectiveness of opening the vessel.”



Dr. Antoni Serra, Hospital Sant Pau, Barcelona, Spain

Naviscore features

- Rapid Exchange catheter (RX)
- Guidewire compatibility: max. 0,014"
- NP: 8 atm | RBP: 20 atm
- Pt/Ir radiopaque markers
- Proprietary hydrophilic coating Hydrax plus
- 6F compatibility

Product with CE mark, certified by Notified Body 0318

Balloon diameter (mm)	Effective length 142 cm				
	Balloon length (mm)				
	6	8	10	12	15
1.50	BCSR14150150006	BCSR14150150008	BCSR14150150010	BCSR14150150012	BCSR14150150015
2.00	BCSR14150200006	BCSR14150200008	BCSR14150200010	BCSR14150200012	BCSR14150200015
2.50	BCSR14150250006	BCSR14150250008	BCSR14150250010	BCSR14150250012	BCSR14150250015
3.00	BCSR14150300006	BCSR14150300008	BCSR14150300010	BCSR14150300012	BCSR14150300015
3.50	BCSR14150350006	BCSR14150350008	BCSR14150350010	BCSR14150350012	BCSR14150350015



The availability of each reference for the sale is linked to the authorization of commercialization in the country of destination

Distributed by

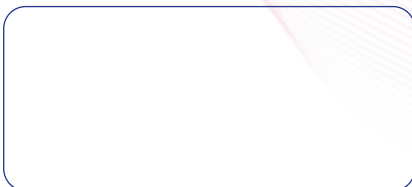

Manufactured by:
Life Vascular Devices Biotech S.L

www.ivascular.global
info@ivascular.global

iVascular[®]

therapies for living

capturer 6F & 7F

Thrombus extraction catheter

PTFE inner layer

specifically designed to
minimize friction and
assure fast thrombus
removal

Innovative tip

guarantees
aspiration power in
all circumstances

HYDRAX



Durable hydrophilic coating
for sustainable performance
and full control



www.ivascular.global

Quick access

Flat-wire braiding
Stiffening mandrel
Hydrophilic coating on the distal part of the device

Increased pushability without kinking to cope with the most tortuous anatomy

Forceful

- Superior extraction capability:
0.99 mm² (6F) - 1.39 mm² (7F)
- **PTFE inner layer** specially designed to minimize friction and assure fast thrombus removal
- **Wire mesh** through the catheter to avoid collapsing during aspiration

Secure

- **2 radiopaque markers** ensure accurate positioning at all times

Capturer features

- > Rapid exchange length: **17.5 cm**
- > Usable length: **140 cm**
- > Entry profile: **0.021" (6F) - 0.025" (7F)**
- > Guiding catheter compatibility **6F & 7F**
- > Guidewire compatibility: **0.014"**
- > **RO** markers

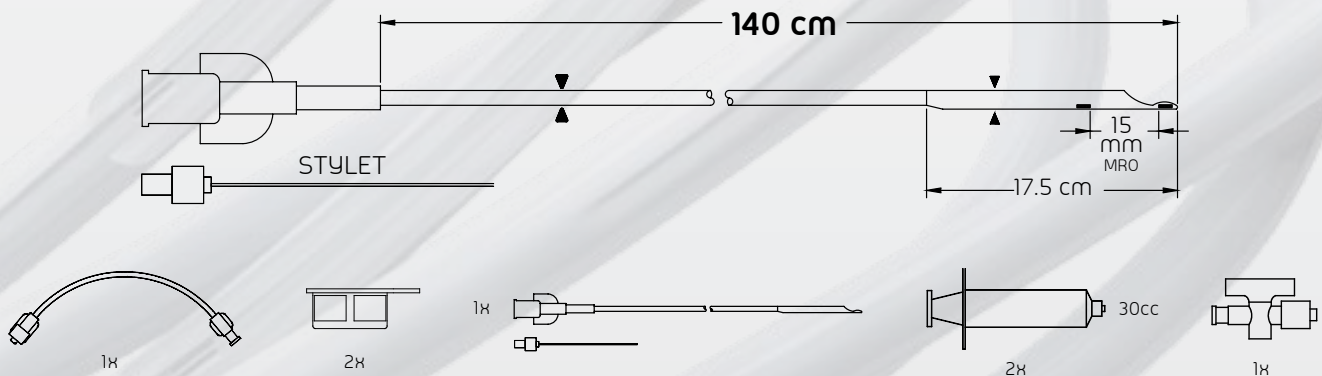

Product with CE mark, certified by Notified Body 0318

References

Capturer 6F	DET R14 145 601
Capturer 7F	DET R14 145 701

The availability of each reference for the sale is linked to the authorization of commercialization in the country of destination

Distributed by:



Manufactured by:

Life Vascular Devices Biotech S.L
www.ivascular.global
info@ivascular.global

iVascular[®]
therapies for living

restorer

Peripheral stent system

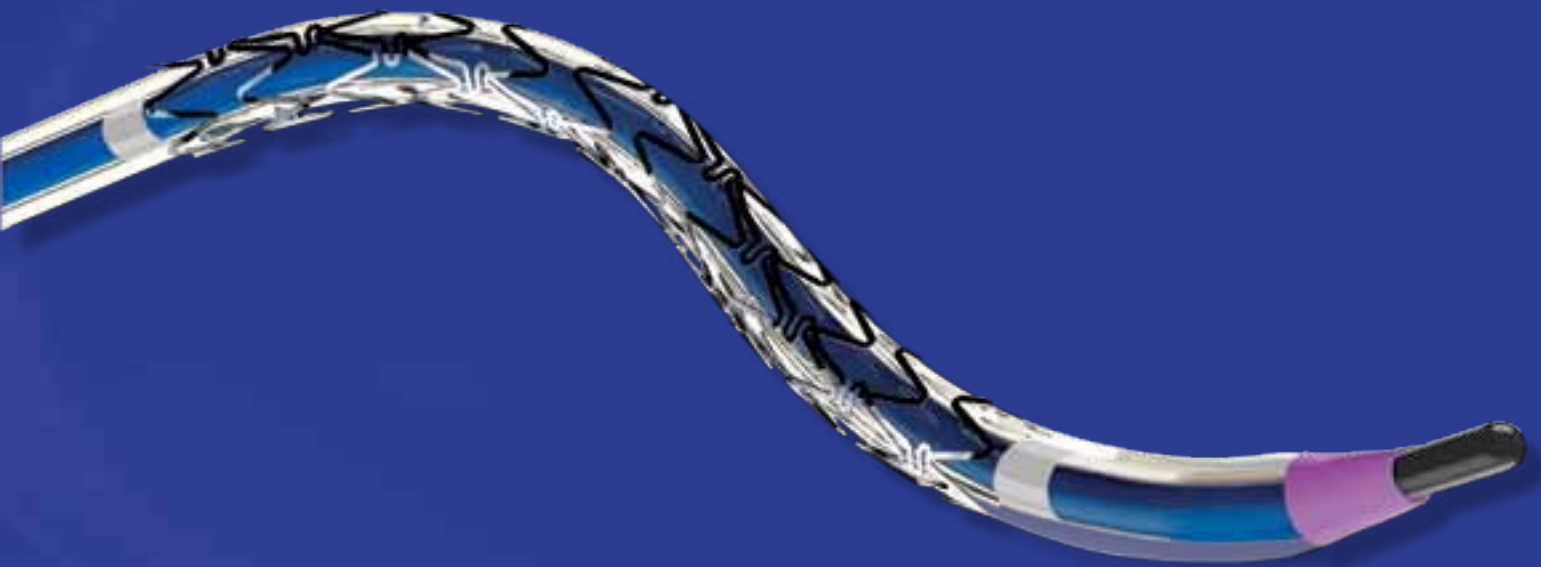

Reach, cross
and deploy



www.ivascular.global

outstanding deliverability

Based on the successful oceanus 35 balloon platform, **restorer** delivers 1st class performance with:

High pushability

Fastest balloon deflation

Enhanced trackability due to **restorer**'s unique, flexible strut design featuring:

Short cells with nested peaks

Helicoidal linkage system

The low profile design of **restorer** ensures increased crossability in difficult lesions.



REACH

CROSS

OPEN

Lower Restenosis

Utilizing an advanced manufacturing process, **restorer** is designed to minimize the potential for restenosis.

Optimized metal content for maximum performance.

Ultrasmooth electropolished surface.

NanoGradient Tech passivation layer for enhanced corrosion resistance and biocompatibility.

extraordinary radial force with less amount of metal

Unique design

The unique design of **restorer** provides superior conformability to the vessel wall.

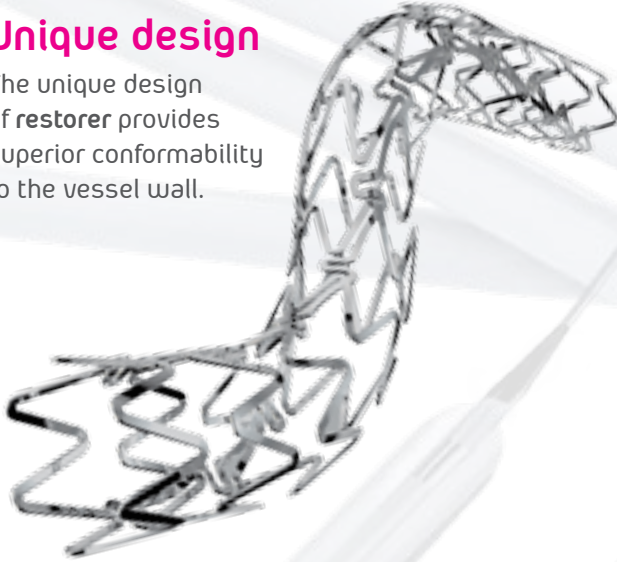

restorer demonstrates excellent vessel support

Ratio Radial Force / Wallthickness

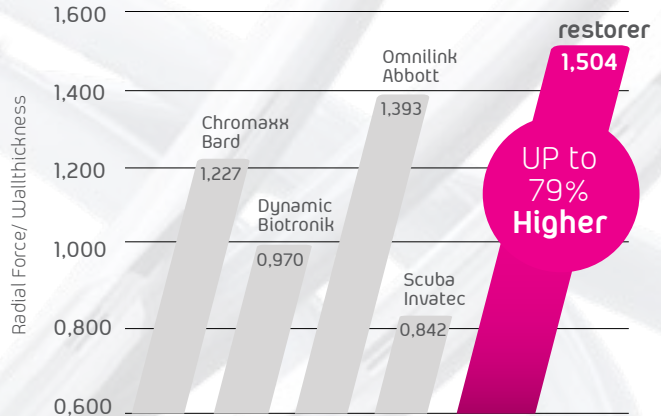

Data for 6mm diameter stents. Tests performed by iVascular. Data on file at iVascular.



New stent quality standard

100% OF **UNITS** | 100% OF **SURFACE**

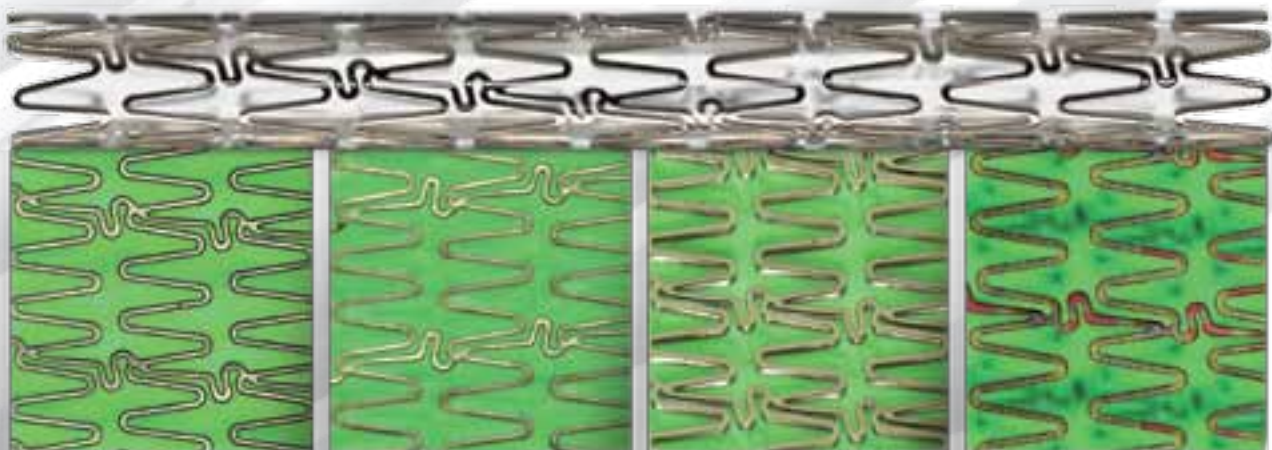

Outer surface

Inner surface

Sidewalls

SensoINSPECT algorithm

Imaging

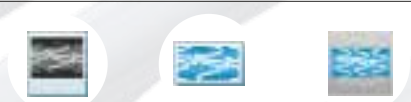

Screenshot

Unrolled FOV

Unrolled section

3D Modes



Surface topography

Surface roughness

5x 10x 20x



High-resolution imaging

restorer - Peripheral stent system

restorer features

- > **Over the wire catheter** (OTW)
- > Usable catheter length: **80 cm & 140 cm**
- > Guidewire compatibility: **0,035"**
- > **Tip Profile:** 0,036"
- > **6F introducer** compatible
- > Material **CoCr L605**
- > Nominal pressure: **10-12 atm**
- > RBP: **16 atm** (Ø 5-6-7 mm stents)
15 atm (Ø 8 mm stents)
14 atm (Ø 9-10 mm stents)
- > Recoil: < **6%**
- > Shortening: < **3%**

Product with CE mark, certified by Notified Body 0318

Stent diameter (mm)	Catheter length: 80 cm			
	Stent length (mm)			
	18	28	38	58
5	SPC BC35 080 050 018	SPC BC35 080 050 028	SPC BC35 080 050 038	SPC BC35 080 050 058
6	SPC BC35 080 060 018	SPC BC35 080 060 028	SPC BC35 080 060 038	SPC BC35 080 060 058
7	SPC BC35 080 070 018	SPC BC35 080 070 028	SPC BC35 080 070 038	SPC BC35 080 070 058
8	SPC BC35 080 080 018	SPC BC35 080 080 028	SPC BC35 080 080 038	SPC BC35 080 080 058
9	SPC BC35 080 090 018	SPC BC35 080 090 028	SPC BC35 080 090 038	SPC BC35 080 090 058
10	SPC BC35 080 100 018	SPC BC35 080 100 028	SPC BC35 080 100 038	SPC BC35 080 100 058

Stent diameter (mm)	Catheter length: 140 cm			
	Stent length (mm)			
	18	28	38	58
5	SPC BC35 140 050 018	SPC BC35 140 050 028	SPC BC35 140 050 038	SPC BC35 140 050 058
6	SPC BC35 140 060 018	SPC BC35 140 060 028	SPC BC35 140 060 038	SPC BC35 140 060 058
7	SPC BC35 140 070 018	SPC BC35 140 070 028	SPC BC35 140 070 038	SPC BC35 140 070 058
8	SPC BC35 140 080 018	SPC BC35 140 080 028	SPC BC35 140 080 038	SPC BC35 140 080 058
9	SPC BC35 140 090 018	SPC BC35 140 090 028	SPC BC35 140 090 038	SPC BC35 140 090 058
10	SPC BC35 140 100 018	SPC BC35 140 100 028	SPC BC35 140 100 038	SPC BC35 140 100 058

The availability of each reference for the sale is linked to the authorization of commercialization in the country of destination

- Introducer compatibility: **6F**
- Introducer compatibility: **6F (min 2.15 mm)**
- Introducer compatibility: **6F (min 2.20 mm)**

Distributed by:

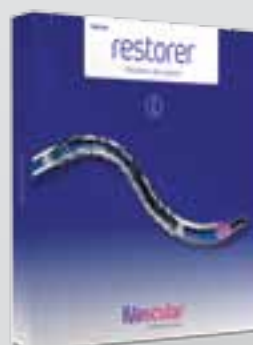

Manufactured by:

Life Vascular Devices Biotech, S.L.
www.ivascular.global
info@ivascular.global

iVascular
therapies for living

angiolite

Sirolimus-eluting coronary stent system

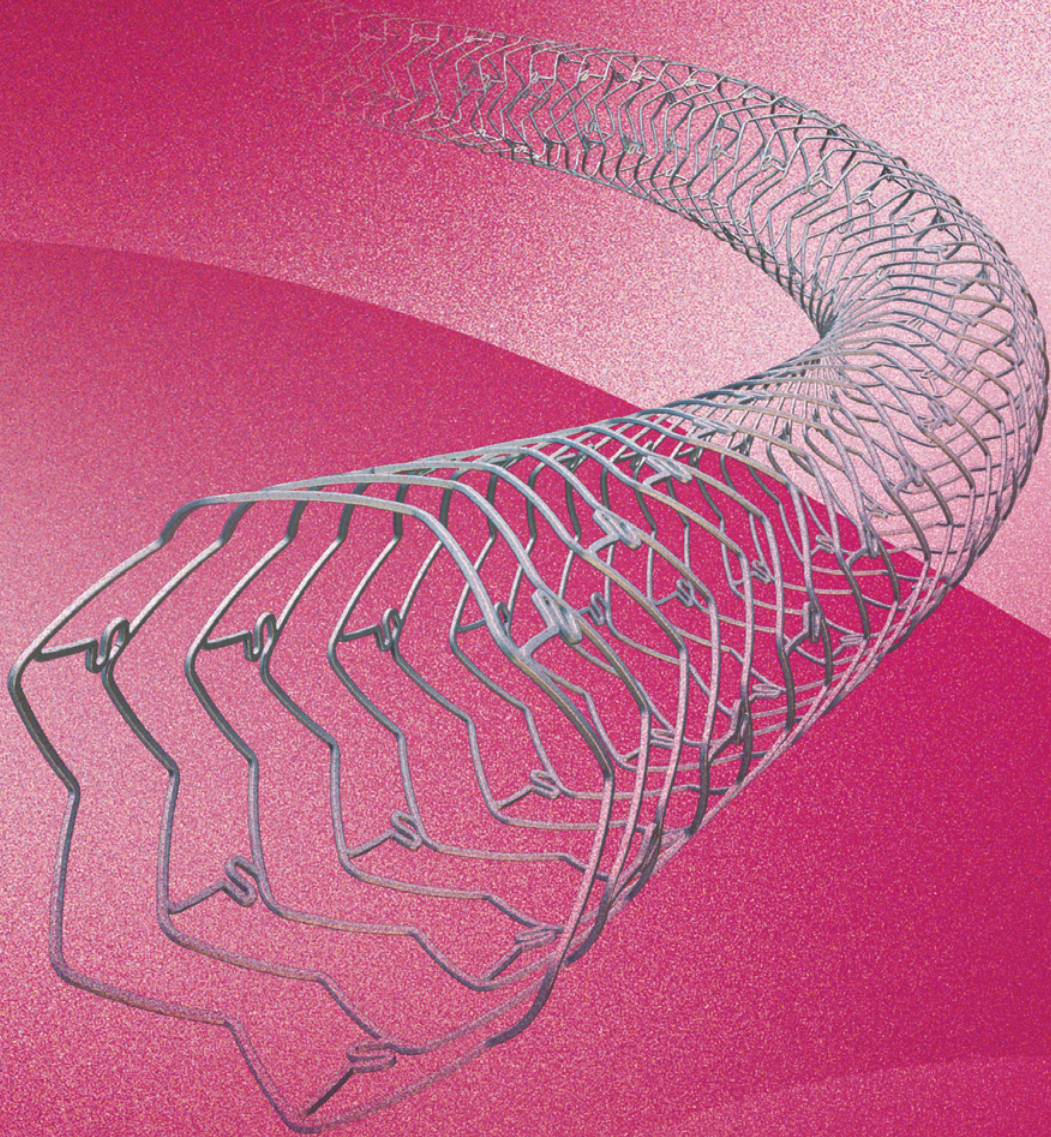

The DES we trust



www.ivascular.global

Outstanding safety and efficacy profile



ANCHOR FIM STUDY⁽¹⁾

Observational, prospective,
multicenter study
103 patients; 2 years follow-up

Angiolite demonstrates
favorable early healing
properties

Strut coverage at
3 months

86.3%

**These outcomes
demonstrate
Angiolite's excellent
performance***

[Click here](#)

(1) Puri R, Otaegui I, Sabaté M,
et al. *Catheter Cardiovasc Interv.*
2017;1-9.

* Main conclusion of the study



ANGIOLITE RCT⁽²⁾

Randomized, non-inferiority, observational, prospective, multicenter trial
223 patients; 2 years follow-up

Angiolite demonstrates non inferiority vs. EES with extraordinary antiproliferative efficacy

LLL at
6 months
0.04mm

Angiolite belongs to the new DES generation^{}**

[Click here](#)

(2) Moreu J. et al. EuroIntervention Dec 2019;15:e1081-e1089
^{**}Author conclusion presented at EuroPCR 2018



RANGO REGISTRY⁽³⁾

Prospective, single arm, multicenter observational registry
646 patients; 5 years follow-up

Angiolite shows high efficacy and a completely safe profile, even in a high risk population

TLF and ST^{**} at
2 years
3.4% and 0.9%

The real-world use of Angiolite warrants the safe use of this potent DES in broader, unselected populations^{*}**

(3) RANGO registry accepted in REC Interv Cardiol.
^{**} Stent thrombosis
^{***} Author conclusion presented at EuroPCR 2021

Excellent performance even in compromised situations

Left main and long bifurcations:
Angiolite offers a high overexpansion capacity*

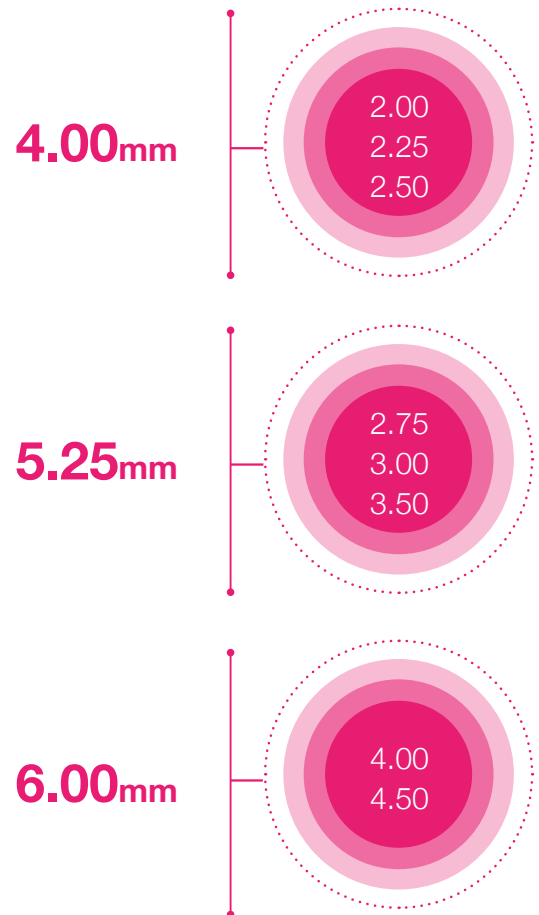

Calcified lesions:
Angiolite offers outstanding arterial support
due to an optimal radial force

40%
Higher radial force
than competitors**

* Angiolite has 3 designs related to stent diameter: S: 2.00 - 2.50mm; M: 2.75 - 3.5mm; L: 4.00 - 4.50mm

** Data on file at iVascular SLU. Average radial force vs Resolute Onyx (Medtronic), Synergy (Boston Scientific) Ultimaster Tansei (Terumo), Orsiro (Biotronik)

Small vessels: Angiolite adapts to the arteries' needs with thin struts

reducing arterial injury
and inflammation score^{(4)**}

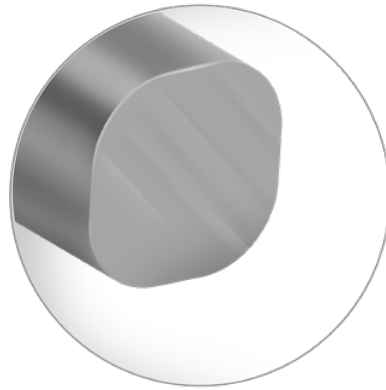

75 μ m

Bifurcations: Angiolite offers excellent side branch access

Stent diameter

**Side branch
maximum cell
diameter**

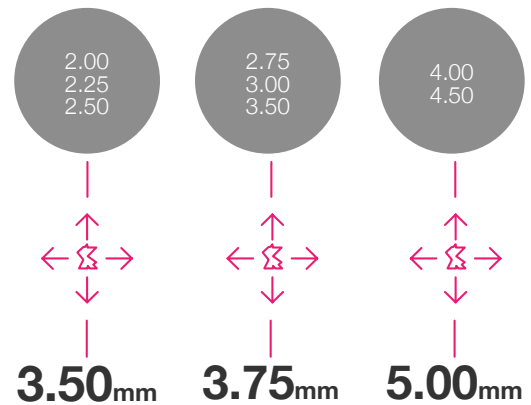

Diffuse lesions: **new long** lengths

Angiolite 49mm, one of
the longest lengths
available on the market

44 and 49 mm



** For diameters < 2.75mm

(4) Sripal Bangalore, et al. Circulation. 2018; 138:2216-2226

High quality of healing

1 Angiolite provides low rates of restenosis and inflammation score⁽⁵⁾



TransferWise
Ensuring homogenous drug elution

TransferWise 3-layer nanotechnology ensures homogenous drug elution

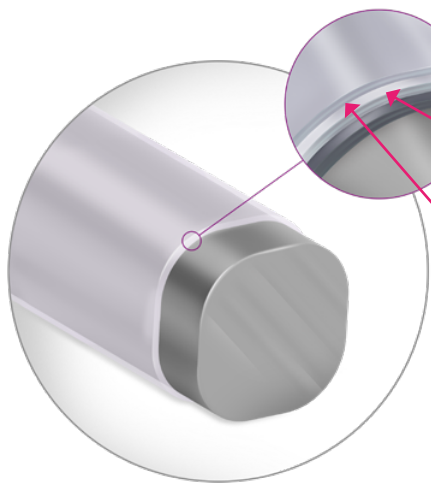

1st layer: Acrylate

Ensures adhesion to the stent

2nd layer: Sirolimus + Fluoro-acrylate polymer

Provides homogenous drug dispersion along the stent

3rd layer: Fluoro-acrylate polymer

Guarantees controlled drug elution

Specific Design



Alternating links ensure homogenous arterial coverage along the whole stent, which **positively influences the reduction of restenosis and inflammation of the lesion**⁽⁵⁾

2 Angiolite shows low rates of stent thrombosis^(1,2,3)

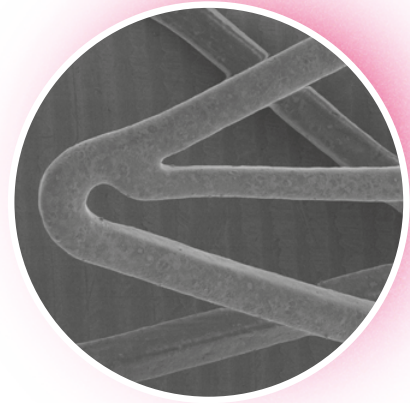

Our fluoro-acrylate polymer provides an early endothelialization and creates a thromboresistant layer. This mechanism suggest to reduce stent thrombosis^(6,7,8)

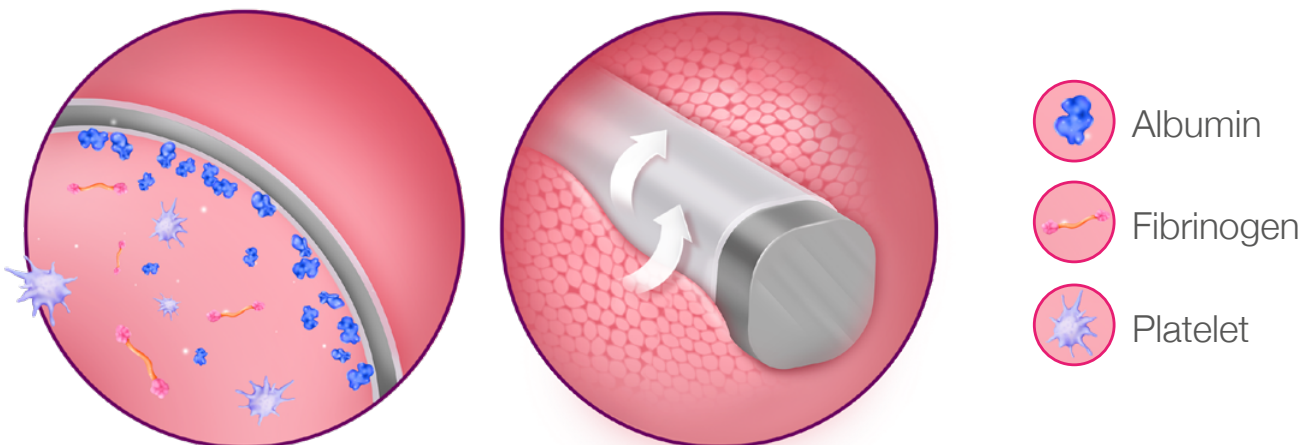

Albumin binds to the fluoro-acrylate polymer, displacing other proteins such as fibrinogen, which is thrombogenic, and creates a thromboresistant layer^(7,8,9,10)

(6) In vitro test, data on file iVascular

(7) Ao PY, et al. Eur J Vasc Endovasc Surg. 2000;20:241-249.

(8) Kumaran Kolandaivelu, et al. Circulation. 2011 Apr 5;123(13):1400-9.

(9) Fumiyuki Otsuka, et al. JACC Cardiovasc Interv. 2015 Aug 17;8(9):1248-1260

(10) Otsuka F, et al. Jacc: cardiovascular interventions vol.8, N°. 9, 2015 Aug 17, 2015: 1248 – 60

Angiolite Features

- Rapid Exchange Catheter (RX)
- Compatible with 0.014" guide wire
- Compatible with 5F guiding catheter
- 2 Radiopaque Makers (Pt - Ir)
- Overexpansion capacity: S: 4.00mm | M: 5.25mm \ L: 6.00mm
- NP: 9-11 atm | RBP: 16 atm | ABP: 22 atm
- Fluoro-acrylate proprietary polymer
- Side Branch access: S: 3.50mm | M: 3.75mm \ L: 5.00mm

Product with CE mark, certified by Notified Body 0318

Stent Diameter (mm)	Effective catheter length 142 cm									
	Stent Length (mm)									
	9	14	16	19	24	29	34	39	44	49
2.00	SCCDSR1415020009	SCCDSR1415020014	SCCDSR1415020016	SCCDSR1415020019	SCCDSR1415020024	SCCDSR1415020029	SCCDSR1415020034	SCCDSR1415020039	-	-
2.25	SCCDSR14150225009	SCCDSR14150225014	SCCDSR14150225016	SCCDSR14150225019	SCCDSR14150225024	SCCDSR14150225029	SCCDSR14150225034	SCCDSR14150225039	-	-
2.50	SCCDSR14150250009	SCCDSR14150250014	SCCDSR14150250016	SCCDSR14150250019	SCCDSR14150250024	SCCDSR14150250029	SCCDSR14150250034	SCCDSR14150250039	SCCDSR14150250044	SCCDSR14150250049
2.75	SCCDSR14150275009	SCCDSR14150275014	SCCDSR14150275016	SCCDSR14150275019	SCCDSR14150275024	SCCDSR14150275029	SCCDSR14150275034	SCCDSR14150275039	SCCDSR14150275044	SCCDSR14150275049
3.00	SCCDSR14150300009	SCCDSR14150300014	SCCDSR14150300016	SCCDSR14150300019	SCCDSR14150300024	SCCDSR14150300029	SCCDSR14150300034	SCCDSR14150300039	SCCDSR14150300044	SCCDSR14150300049
3.50	SCCDSR14150350009	SCCDSR14150350014	SCCDSR14150350016	SCCDSR14150350019	SCCDSR14150350024	SCCDSR14150350029	SCCDSR14150350034	SCCDSR14150350039	SCCDSR14150350044	SCCDSR14150350049
4.00	SCCDSR14150400009	SCCDSR14150400014	SCCDSR14150400016	SCCDSR14150400019	SCCDSR14150400024	SCCDSR14150400029	SCCDSR14150400034	SCCDSR14150400039	SCCDSR14150400044	SCCDSR14150400049
4.50	-	SCCDSR14150450014	SCCDSR14150450016	SCCDSR14150450019	SCCDSR14150450024	SCCDSR14150450029	SCCDSR14150450034	SCCDSR14150450039	-	-

The availability of each reference for the sale is linked to the authorization of commercialization in the country of destination

Distributed by:



Manufactured by:
Life Vascular Devices Biotech S.L
www.ivascular.global
info@ivascular.global



angiolite
 Sirolimus-eluting coronary stent system
The DES we trust



iNdeep

Microcatheter

Designed to reach
the distal intracranial vasculature

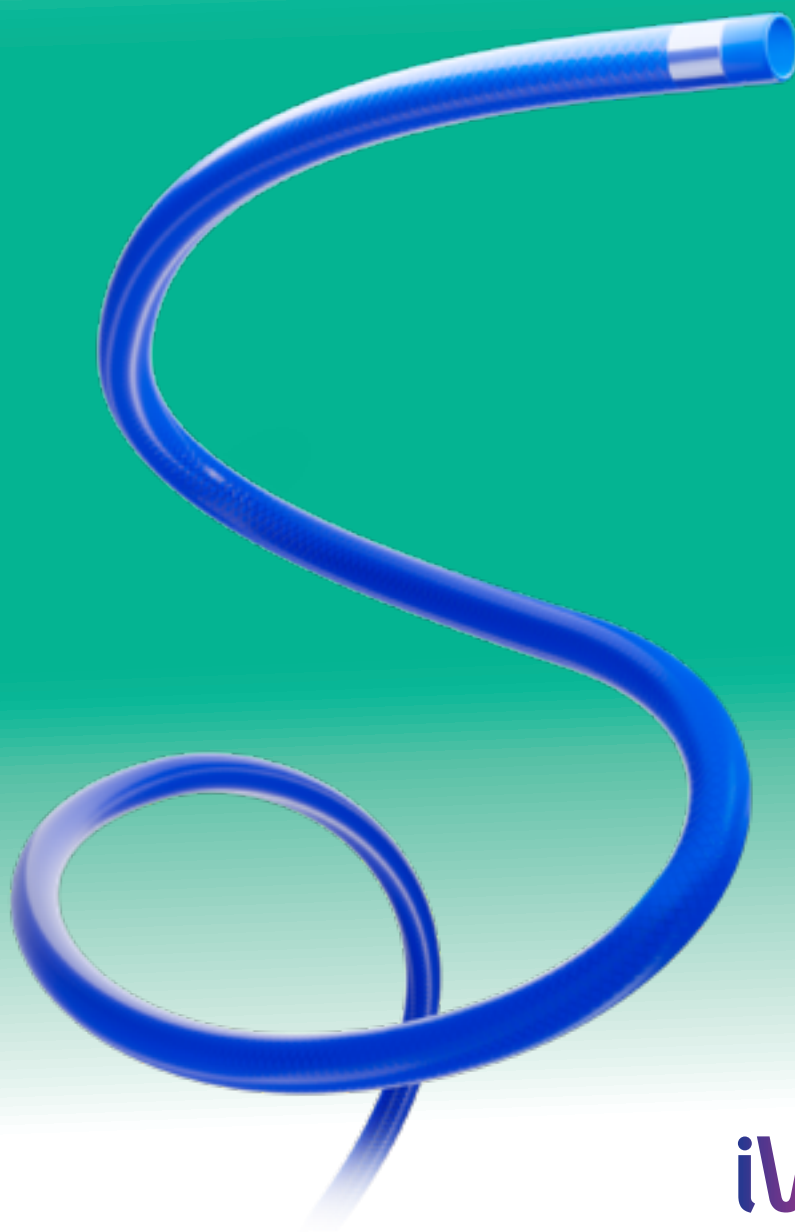

iVascular[®]
therapies for living



iNdeep, microcatheter family, designed to navigate in challenging anatomies

iNdeep, safe navigation in tortuous anatomies and distal areas.

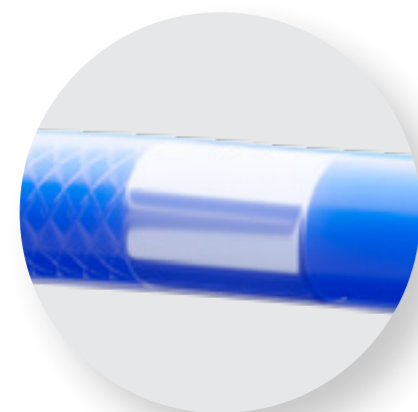

Exceptional visibility
C-Cut radiopaque marker at the distal end

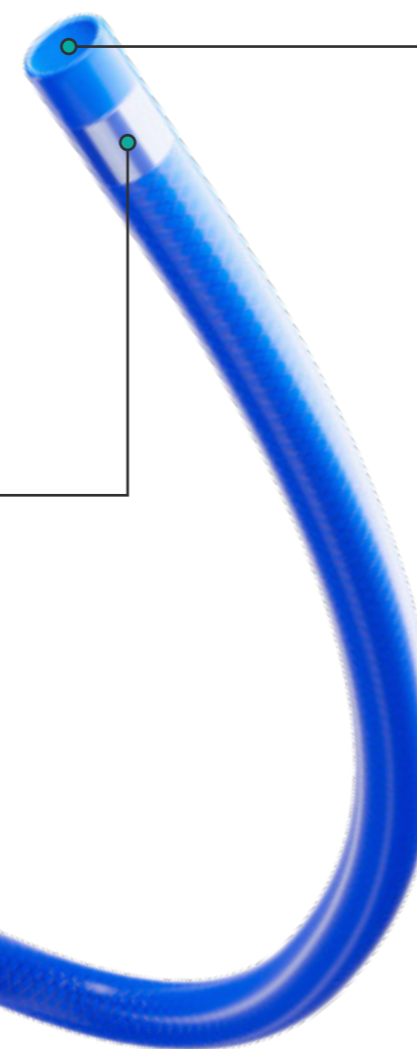

Optimal navigation

- Hydrax Plus hydrophilic coating, iVascular's proprietary technology.
- Rounded tip design

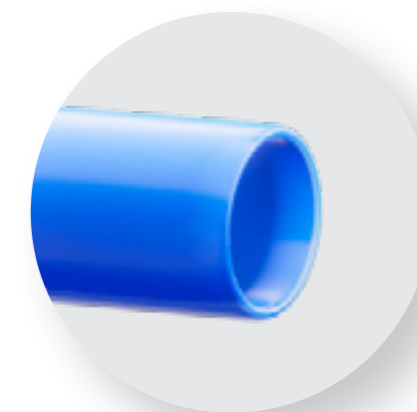

Excellent pushability

Braid and transition design tailored to each model according to the microcatheter functional requirements

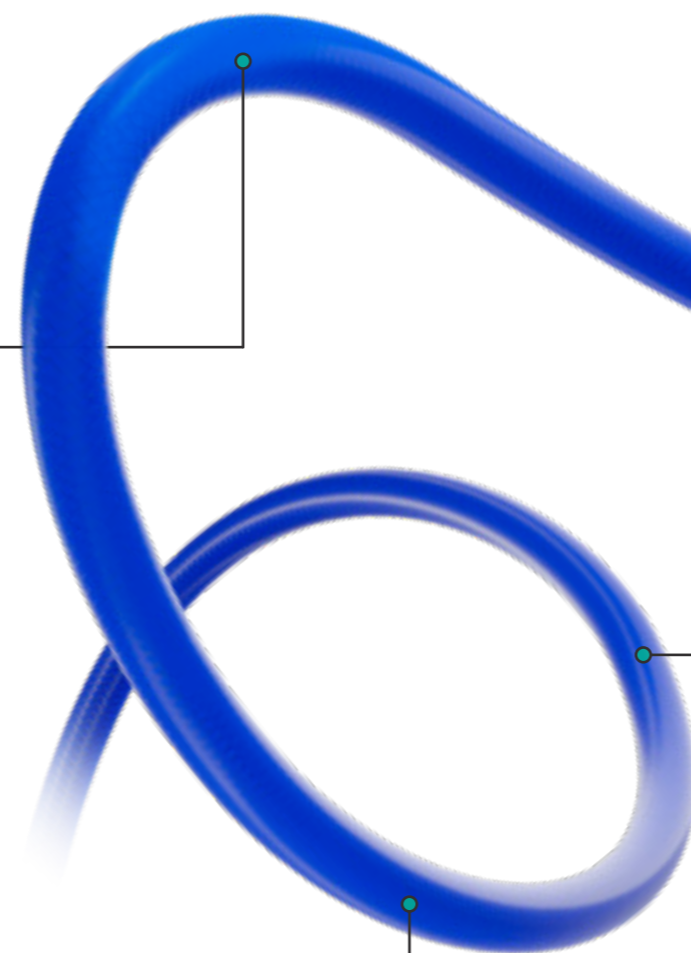

Complete range of sizes
iNdeep 17, 21 and 27
compatible with all retriever devices sizes

Specific design of the luer connector **to facilitate the retriever insertion into the microcatheter**

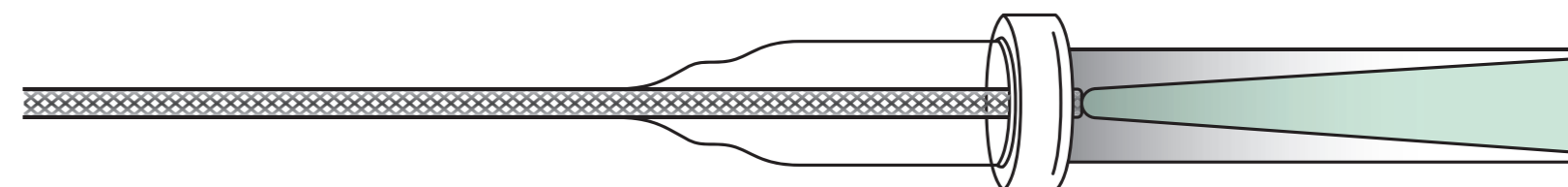

165cm length in the whole product family



iNdeep features

- > Complete family of microcatheters: 0,017", 0,021" and 0,027" compatible with all retriever devices.
- > DMSO compatible
- > 1 Radiopaque marker at the tip
- > Maximum infusion pressure: 600 psi
- > Minimum introducer ID 0,053"/ 1,35 mm
- > 165cm length in the whole family product, compatible with intermediate devices.

- > Maximum recommended guidewire:
 - iNdeep 17 - (\leq 0,014")
 - iNdeep 21 - (\leq 0,018")
 - iNdeep 27 - (\leq 0,018")

Includes

- > Shaping mandrel
- > Card holder with ruler

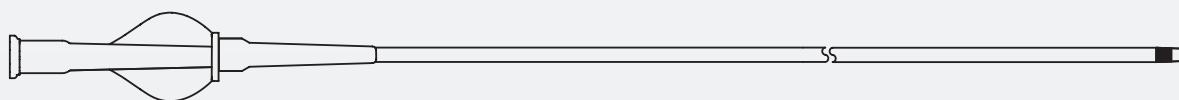

CE mark product. Certified by Notified Body 0318

Description	ID	Profile (proximal / distal)	Effective length	Retriever device \varnothing compatibility	Hydrophilic coating length	Dead space 150cm length	Dead space 165cm length
iNdeep 17	0,017" (0,43mm)	2,55 / 1,95 F	165 cm	3 - 4 mm	100 cm	-	0,40 cc
iNdeep 21	0,021" (0,55mm)	2,85 / 2,28 F	150 / 165 cm	4 - 6 mm	100 cm	0,52 cc	0,56 cc
iNdeep 27	0,027" (0,69mm)	3,00 / 2,58 F	150 / 165 cm	6 mm	100 cm	0,73 cc	0,78 cc

The availability of each reference for the sale is linked to the authorization of commercialization in the country of destination

References	Effective length (cm)	
	150	165
iNdeep 17	-	MCNC17165001
iNdeep 21	MCNC21150001	MCNC21165001
iNdeep 27	MCNC27150001	MCNC27165001



Distributed by:

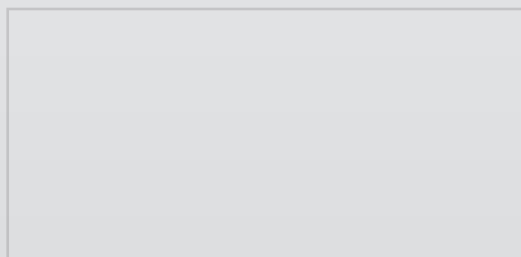

Manufactured by:

Life Vascular Devices Biotech S.L.
www.ivascular.global
info@ivascular.global

iVascular
 therapies for living

MPS3371 Ed.0 Jan 2023