

Processor

OPERATION MANUAL

EP-6000

Thank you for purchasing our product. Read this manual carefully before use to avoid unexpected accidents and to take full advantage of the product's capabilities.

Introduction

- 1 Precautions
- 2 System Configuration
- 3 Name and Function of Each Part
- 4 System Installation and Initial Settings
- 5 Function Settings
- 6 Preparation and Inspection of the System
- 7 Method of Use
- 8 Image Recording
- 9 Storage and Maintenance
- 10 Troubleshooting
- 11 Main Specification





Contents at a Glance

Introduction

Read and understand this manual fully before using this product.

Chapter 1 Precautions

This chapter describes the warnings and cautions for safe operation of this product.

Chapter 2 System Configuration

This chapter describes the equipment used in combination with this product.

Chapter 3 Name and Function of Each Part

This chapter describes the name and function of each part of this product.

Chapter 4 System Installation and Initial Settings

This chapter describes the methods of installation and initial settings of this product.

Chapter 5 Function Settings

This chapter describes how to set each function of this product.

Chapter 6 Preparation and Inspection of the System

This chapter describes the inspection and preparation methods to be performed for using this product.

Chapter 7 Method of Use

This chapter describes a series of operations of this product.

Chapter 8 Image Recording

This chapter describes how to record images.

Chapter 9 Storage and Maintenance

This chapter describes the methods of storage and maintenance of this product.

Chapter 10 Troubleshooting

This chapter describes actions should be taken if problems occur in this product.

Chapter 11 Main Specification

This chapter describes the main specification of this product.

Contents

Contents at a Glance	iii
Introduction	1
About This Manual	1
How to Read This Manual	3
◆ Terms	3
◆ Conventions Used in This Manual	3
Chapter 1 Precautions	1-1
1.1 Safety	1-1
◆ Category of Equipment	1-1
1.1.1 Infection	1-2
1.1.2 Direct Harm to Human Body	1-2
1.2 Cautions/Warnings	1-3
1.2.1 Intended Use	1-3
1.2.2 Installation	1-3
1.2.3 Clinical Procedures	1-3
1.2.4 Difference of Color Tone	1-3
1.2.5 Loss of Function	1-4
1.2.6 Combination of Equipment	1-4
1.2.7 Installation of equipment	1-4
1.2.8 Transferring the equipment	1-6
1.2.9 Electric Shock	1-6
1.2.10 Explosion	1-6
1.2.11 Foreign Matter and Liquid	1-6
1.2.12 High Voltage	1-7
1.2.13 Maintenance	1-7
1.2.14 Preparation and inspection before use	1-7
1.2.15 Temperature at distal end	1-8
1.2.16 Disposal	1-8
1.2.17 Security Function	1-8
1.2.18 Handling of this equipment	1-8
1.2.19 Potential equalization	1-9
1.2.20 System Version	1-9
1.2.21 Electromagnetic interference	1-9
1.2.22 Using This Product by Connecting to Equipment (EX-WS) with EW1 System Software	1-10
Chapter 2 System Configuration	2-1
2.1 Checking Package Components	2-1
◆ Package Components	2-1
2.2 Equipment Using in Combination	2-2
2.3 Standard System Configuration	2-4

2.4	System Expansion.....	2-6
Chapter 3	Name and Function of Each Part	3-1
3.1	Front Panel.....	3-1
3.2	Rear Panel	3-4
3.3	Side Panel.....	3-6
3.4	Keyboard.....	3-7
3.5	Socket Protection Cap.....	3-10
3.6	Caution Label	3-10
3.7	Rating Plate.....	3-10
3.8	Symbols.....	3-11
3.9	Data Display on the Observation Screen	3-12
3.10	Displaying FICE Set	3-21
3.11	Patient Info. + Scope Info. Dialog.....	3-23
Chapter 4	System Installation and Initial Settings	4-1
4.1	System Installation	4-1
4.1.1	Installation Flowchart	4-3
4.1.2	Installation onto the Cart (Standard System Installation Example).....	4-4
4.1.3	Connecting the WC-LINK cable	4-7
4.1.4	Attaching the Dustproof Filter (Louver)	4-8
4.1.5	Connecting the Monitor	4-9
4.1.6	Connecting the Keyboard.....	4-10
4.1.7	Installation for System Expansion	4-11
4.1.8	Printer Connection (Remote System)	4-13
4.1.9	Printer Connection (RS-232C System)	4-15
4.1.10	Digital Printer Connection	4-16
4.1.11	Video Recorder Connection (Remote System).....	4-17
4.1.12	Connecting the Power Source	4-18
4.1.13	Power Source.....	4-20
4.1.14	Connecting the Power Source When Using the Cart.....	4-22
4.1.15	Basic Information on Power Cord	4-23
4.1.16	Connecting Equipment (EX-WS) with EW1 System Software	4-24
4.2	Initial Settings at the Time of Installation.....	4-25
4.2.1	Flowchart of System Settings at the Time of Installation	4-25
4.2.2	Basic System Setup Operations	4-27
4.2.3	Function Tab	4-29
4.2.4	Display Tab	4-32
4.2.5	Basic Setting Tab.....	4-34
4.2.6	Light Source Tab.....	4-36
4.2.7	Endoscope Tab.....	4-37
4.2.8	Setting Foot Switch (FS1)	4-50
4.2.9	Setup for Switching the Shutter Speed During Optical Zoom	4-53
4.2.10	Setting the Doctor's Name	4-54
4.2.11	Setting the Procedure Name.....	4-59

4.2.12	Setting the Message	4-63
4.3	Security Function.....	4-67
4.3.1	Access Control with the Security Function.....	4-68
4.3.2	Logging in to the Security Function (Changing the Password)	4-69
4.3.3	Logging off the Security Function.....	4-71
Chapter 5	Function Settings	5-1
5.1	Hierarchical Structure of the Setting Screens	5-1
5.2	Registering and Editing Patient Information	5-8
5.2.1	Registering Patient Information.....	5-8
5.2.2	Calling Up Patient Information	5-19
5.2.3	Amending Patient Information.....	5-21
5.2.4	Deleting Patient Information.....	5-24
5.3	Setting the Panel Buttons (Image Processing Functions).....	5-27
5.3.1	Basic Setup Operations	5-27
5.3.2	Structure Emphasis Settings.....	5-29
5.3.3	Setting FICE.....	5-30
5.3.4	Tone Settings	5-32
5.3.5	Color Adjustment Settings.....	5-34
5.3.6	Setting the Shutter Speed	5-36
5.3.7	Setting the Iris Mode	5-38
5.3.8	Special Light Observation Preset Setup	5-39
5.4	Peripheral Settings	5-41
5.4.1	Basic Setup Operations	5-41
5.4.2	Memory Tab	5-42
5.4.3	Printer Tab	5-45
5.4.4	Details Tab	5-46
5.5	Other Settings	5-48
5.5.1	Registering, Calling Up and Editing and Deleting Image Setup Page	5-48
5.5.2	Index Image Display.....	5-57
5.5.3	Setting Freeze Mode.....	5-58
5.5.4	Setting Multi Zoom Mode	5-60
5.5.5	Lap Time Display	5-61
Chapter 6	Preparation and Inspection of the System	6-1
6.1	Installing and Connecting the Equipment.....	6-1
6.2	Preparing Related Equipment	6-1
6.3	Operation Check of Processor	6-2
6.4	Registering and Calling Adjustment Value	6-7
6.5	Registering the Patient Information	6-7
6.6	Calling up the Patient Information	6-7
Chapter 7	Method of Use	7-1
7.1	Preparing the Equipment.....	7-3

7.2	Connecting the Endoscope and Equipment	7-4
7.3	How to Use the Endoscope and Related Equipment	7-7
7.4	Supplying Power to the Equipment	7-8
7.5	Operation of Air Supply Pump	7-8
7.6	Turning On the Light Source	7-9
7.7	Turning Off the Light.....	7-9
7.8	Adjusting the Brightness.....	7-10
7.9	Light Save Function.....	7-11
7.10	Switching Observation Mode.....	7-13
7.11	Turning On/Off Structure Emphasis	7-14
7.12	Turning On/Off FICE	7-15
7.13	Turning On/Off the Tone	7-16
7.14	Switching the Shutter Speed	7-17
7.15	Switching the Iris Mode	7-18
7.16	Adjusting the Electronic Zoom.....	7-20
7.17	Data Display Operation	7-21
	7.17.1 Entering Comments	7-21
	7.17.2 Starting/Stopping the Timer	7-22
	7.17.3 Lap Time Function	7-24
7.18	Starting the Examination	7-25
7.19	Finishing the Examination	7-26
	7.19.1 Finishing the First Examination	7-26
	7.19.2 Starting the Second Examination or Later	7-27
	7.19.3 Finishing All Examinations	7-28
7.20	How to Use EW1 System Software	7-29
Chapter 8	Image Recording	8-1
8.1	Method of Controlling the Color Printer	8-1
8.2	Printing the Image with the Color Printer (Remote System).....	8-2
	8.2.1 Assignment of Image Capture Switches	8-2
	8.2.2 Printer Setting	8-2
	8.2.3 Capturing the Image.....	8-3
	8.2.4 Printing the Image	8-5
8.3	Printing the Image with the Color Printer (RS-232C System)	8-6
	8.3.1 Assignment of Image Capture Switches	8-7
	8.3.2 Printer Setting	8-7
	8.3.3 Capturing the Image.....	8-7
	8.3.4 Printing the Image	8-8
8.4	Printing the Image with the Digital Printer	8-9
	8.4.1 Assignment of Image Capture Switches	8-9
	8.4.2 Printer Setting	8-10
	8.4.3 Capturing the Image.....	8-10
	8.4.4 Print Mode Setting.....	8-11

8.5	Recording Video Images on the Video Recorder (by Operating the Buttons).....	8-13
8.5.1	Recording Video Images by Operating the Buttons on the Video Recorder	8-13
8.6	Recording Video Images on the Video Recorder (by Operating the Scope Switch).....	8-15
8.6.1	Assignment of Video Recording Switches	8-15
8.6.2	Starting Video Recording	8-15
8.7	How to Record/Print Images on the Internal and External Storage Devices	8-16
8.7.1	Internal Storage Device.....	8-16
8.7.2	Assignment of Image Capture Switches	8-17
8.7.3	Capturing the Image to Internal Storage Device	8-17
8.8	Copying Images to External Storage Device.....	8-19
8.8.1	External Storage Device	8-19
8.8.2	Copying Images to an External Storage Device	8-19
8.8.3	Checking Images on a Personal Computer	8-23
8.9	How to Search and Print Images in Internal and External Storage Devices	8-25
8.9.1	Searching Images in Internal and External Storage Devices.....	8-25
8.9.2	Transferring Searched Images.....	8-31
8.9.3	Deleting Searched Images.....	8-32
8.9.4	Printing Searched Images (only for digital printer).....	8-33
Chapter 9	Storage and Maintenance	9-1
9.1	Care after Use of Processor.....	9-1
9.2	Cleaning the Keyboard.....	9-2
9.2.1	Cleaning the Keyboard.....	9-2
9.2.2	Keyboard Cover and Replacement.....	9-2
9.3	Cleaning the Dustproof Filters.....	9-3
9.4	Storage.....	9-5
9.4.1	Storage of the processor.....	9-5
9.4.2	Storage of the Water Tank.....	9-5
9.5	Relocation	9-6
9.6	Cleaning and Disinfecting (or Sterilizing) the Water Tank.....	9-7
Chapter 10	Troubleshooting	10-1
10.1	Troubleshooting.....	10-1
10.2	Error Messages	10-6
Chapter 11	Main Specification	11-1
11.1	Specification	11-1
	◆ Classification of Medical Electrical Equipment.....	11-1
	◆ Applied Part	11-1
	◆ Specification.....	11-2
	◆ Operating Environment	11-4
	◆ Transport and Storage Environment.....	11-4
	◆ Term of Validity/Period for Use (Durability).....	11-4

◆ Input/Output Connector.....	11-4
◆ Block Diagram.....	11-5
◆ Medical Device Directive.....	11-5
11.2 Electromagnetic Compatibility (EMC) Information.....	11-6
11.3 Software Used in This Product.....	11-16
11.4 After-Sales Service.....	11-24
11.5 Disposal of Electric and Electronic Equipment.....	11-25
11.6 Index.....	11-26
Service Center	

Introduction

Read and understand this manual carefully before operating the equipment.

About This Manual

This manual provides necessary information for using this product, such as the operation procedures, settings and how to install the system.

If you are a first-time user of this product, be sure to read this manual before actual operation. Also, after reading this manual, store it close to this product for future reference.

For information on how to use the endoscope and peripherals, refer to the respective operation manuals.

The peripherals include: LCD monitor, cart, printer, video recorder, ultrasonic processor and electro-surgical unit.

For details of the connections of the ultrasonic processor and electro-surgical unit, refer to the respective operation manuals.

For details on how to use each piece of medical device software that can be used in combination with this product, refer to the respective operation manuals.

Trademarks

The company names and product names described in this manual are trademarks or registered trademarks of FUJIFILM Corporation or its subsidiaries.

Other holders' trademarks

All other company names and product names described in this manual are trademarks or registered trademarks of their respective owners.

Copyright © 2017-2019 FUJIFILM Corporation. All rights reserved.

Store this operation manual carefully.

Processor EP-6000 Operation Manual

This manual provides necessary information for using this product such as the equipment overview, operation procedures and precautions to observe.

Note

- This product is used in combination with peripherals. Refer to the operation manual of each peripheral device described in “2.2 Equipment Using in Combination”.

CAUTION

- No part or all of this manual may be reproduced in any form without prior permission.
- The information contained in this manual may be subject to change without prior notice.
- FUJIFILM Corporation shall not be liable for malfunctions or damages caused by installation, relocation, remodeling, maintenance, and repair performed by dealers other than those specified by FUJIFILM Corporation.
- FUJIFILM Corporation shall not be liable for malfunctions or damages of FUJIFILM Corporation products due to products of other manufacturers not supplied by FUJIFILM Corporation.
- FUJIFILM Corporation shall not be liable for malfunctions or damages caused by remodeling, maintenance, and repair using repair parts other than those specified by FUJIFILM Corporation.
- FUJIFILM Corporation shall not be liable for malfunctions or damages resulting from negligence of the precautions and operating methods contained in this manual.
- FUJIFILM Corporation shall not be liable for malfunctions or damages resulting from use under environment conditions outside the range specified for this product, such as the power supply, installation environment, etc., as described in this manual.
- FUJIFILM Corporation shall not be liable for malfunctions or damages resulting from natural disasters, such as fires, earthquakes, floods, lightning, etc.

- This product has heavy metal parts. When disposing of this product, comply with local laws and regulations in your area. Determine whether or not the product is to be treated as a biohazard, then handle and dispose of accordingly.
- Before disposing of this product or an endoscopic accessory, perform cleaning and disinfection (or sterilization) according to the procedure described in the operation manual. There is a risk of being a source of infection.

How to Read This Manual

◆ Terms

Term	Description
Reprocessing	It refers to disinfection or sterilization performed after the manual cleaning of the endoscope and its accessories.
This product	If refers to the processor.
Standard accessory	It refers to the parts and devices included in the package or supplied with this product.

◆ Conventions Used in This Manual

This manual uses the following conventions for easier understanding.

General Conventions

Convention	Description
WARNING	Explains dangerous situations that may cause death or serious injury if not avoided.
CAUTION	Explains situations that may cause slight or moderate levels of injury if not avoided. Explains situations that may cause damage to equipment if not avoided.
(1), (2), (3), ...	Indicates consecutive numbers in operating procedures for the order in which successive steps in the procedure should be taken.
Note	Indicates a comment or supplementary information.
→	Indicates a reference.

1.1 Safety

Before using this product, read this section carefully so that you can operate it correctly. Whenever you operate this product, be sure to observe those precautions. Failure to do so may cause you to subject to injuries or property damage to occur.

WARNING

- The institution is responsible for the use and maintenance of this product. In addition, this product should not be used by persons other than doctors or suitably trained staff.
- Be sure to prepare a spare endoscope against unexpected accidents such as the failure of this product. Otherwise, you may not be able to continue the endoscopic procedure. If the spare endoscope is not available, prepare other alternative means such as abdominal surgery. This product is intended for use by medical professionals who have received proper training in endoscopic procedures. This manual does not provide information about clinical procedures or any aspects of endoscopic techniques.

CAUTION

- Do not modify this product or its components, and do not disassemble, repair or in any other way reverse-engineer these products. Even if you find a defect, do not attempt to repair these products yourself. FUJIFILM Corporation shall not be liable for any defects or device failures caused by such modifications, disassembly, repairs or reverse-engineering. If this product is disassembled or modified, it creates a risk of human injury or equipment damage, and is unable to ensure its functionality.

◆ Category of Equipment

<Classification of Medical Electrical Equipment>

1. Type of protection against electric shock:

Class I equipment (Power supply: Protective earth plug)

2. Degree of protection against electric shock:

Type BF applied part

3. Degree of explosion protection:

Use is prohibited in an oxygen-rich environment or in a flammable gas atmosphere.

1.1.1 Infection

WARNING

- Replace keyboard cover whenever it becomes stained and/or in contact with patient material/fluids or is suspected of being contaminated. Not doing so presents an infection risk.

1.1.2 Direct Harm to Human Body

WARNING

- If any peripherals not described in “2.2 Equipment Using in Combination” are used, this product may not function properly and it may cause damage to the peripherals or injury to patients or physicians.
- This product conforms to the EMC standard (EN 60601-1-2: 2015). However, the radio waves radiated from this product may cause medical devices such as a pacemaker to malfunction. When this product is used for a patient with an active implantable medical device, consult a cardiovascular specialist and the manufacturer of the active implantable medical device.

CAUTION

- To avoid damage to eyes, do not look at the light directly while the light is turned on. Do not look directly at the light from the endoscope.
- Do not look directly into the light when it is on. Do not look directly into the illumination light of the endoscope. Otherwise, eye damage may occur.
- Immediately after removing the scope connector from the light source, do not touch the light guide prong with your hands since it may be extremely hot. There is a risk of burns. Do not touch the light guide prong until it has cooled down (approximately 5 minutes).
- Set a suction pressure at 40 to 53 kPa or less. The endoscope may adhere to the mucous membrane, resulting in damage to the mucous membrane.
- Insert it securely all the way so that there are no gaps while it is connected to the endoscope. Do not look into the endoscope connection section. The light of the light source may cause eye damage.
- If the brightness level is high, the surface temperature at and around the distal end of the endoscope may exceed 41°C. Do not allow the distal end to remain in contact with the same site for an extended period of time. It may cause burn injury.

1.2 Cautions/Warnings

Observe the following cautions when handling this product. Also, there are some cautions in each chapter.

1.2.1 Intended Use

WARNING

- This product is intended to be used in combination with a FUJIFILM medical endoscope, monitor, recorder and various peripherals for observation, diagnosis, endoscopic treatment, and image recording in medical facilities under the management of physicians. Never use this product for any other purposes.
- Do not rely on the BLI observation mode alone. Perform comprehensive observation and diagnosis including normal observation for all target regions. Not doing so may result in improper observation and diagnosis. Information obtained from the BLI mode image should be regarded as reference information and it does not assure the validity of diagnosis.

1.2.2 Installation

WARNING

- Only service personnel are allowed to install this system. No one except such personnel should install this system.

1.2.3 Clinical Procedures

WARNING

- This manual assumes that the product will be used by medical specialists who have received proper training in endoscopic procedures. This manual does not provide information about clinical procedures. Proper clinical judgment should be exercised for all clinical procedures.

1.2.4 Difference of Color Tone

WARNING

- When using FICE, BLI, BLI-bright or LCI, use it after sufficiently understanding the difference between the color tone and brightness of the usual viewing image and FICE, BLI, BLI-bright or LCI image. Also check the usual viewing image for diagnosis.

1.2.5 Loss of Function

CAUTION

- During an examination, if an abnormality occurs on the endoscopic image (if it disappears, becomes darker or brighter, etc.), the imaging section may be damaged. If an error message appears, follow the displayed instructions. If no error message appears, slowly withdraw the endoscope by following the instructions described in the operation manual of the endoscope in use.
Stop using the equipment immediately, and consult your local dealer. Continued use of the endoscope may cause overheating of the distal end, possibly resulting in burn injury.
- If “Full HD” is selected for “Screen Resolution” when a non-Full HD monitor is used, the image is not displayed properly on the monitor. If this happens, press the [Ctrl], [Alt] and [S] keys at the same time. The screen resolution setting changes to “SXGA” and a buzzer sounds. When a buzzer sound is heard, restart the processor. If a buzzer sound is not heard, check whether or not the correct keys are pressed and then try again.

Note

- Wait for 5 seconds or more before turning the power back to ON.
- For details on how to operate the endoscope, refer to the operation manual of the endoscope.

1.2.6 Combination of Equipment

WARNING

- This product is used in combination with peripherals. To avoid electric shock, do not use peripherals that are not specified in “2.2 Equipment Using in Combination”.

CAUTION

- If the range of the operating environment for a peripheral device is narrower than the range of the operating environment for this product, use this product within the range of the operating environment for the peripheral device.

1.2.7 Installation of equipment

WARNING

- To avoid electric shock and equipment toppling over, observe the following precautions when installing the equipment.
<To avoid electric shock>
- Properly connect and install the devices in “2.2 Equipment Using in Combination” in this manual according to “4.1 System Installation” in the same manual before use.
- Connect the power plugs of this product directly to the receptacles for the processor/light source on the cart.
- Never connect the power source of an electrosurgical unit to the cart.

WARNING

- Never connect the power source of this product to a power cord that has been placed on the floor.
- Never connect the power source of a second cart to the first cart.
- Additional power strips or extension cords must not be connected to the medical system.
- Do not connect any unit other than the equipment composing this system to the power strip.

<To avoid toppling over of equipment>

- Do not stack the peripherals.
- Make sure that the feet of each unit are placed inside of the stoppers.
- Make sure that the feet of each unit are placed inside of the stoppers on the movable shelf of the cart.

<To avoid malfunction due to lightning>

- Connect the equipment to a power source suitable for the structure and facilities of the hospital or clinic.
- If the power cords of the peripherals are connected without using the insulation transformer on the cart, the enclosure leakage current may increase, posing a risk of injury or electric shock to the patient and/or the physician when he/she comes into contact with those devices.
- When using a network, insert an EN 60601-1 compliant separator between the LAN cable, which connects the devices, and the network system. If such a separator is not used, the enclosure leakage current may increase due to the current being leaked from the connected network system or due to the electric potential difference between grounds. This may pose a risk of injury or electric shock to the patient and/or the physician when he/she comes into contact with the devices.

CAUTION

- Configure the ME system in accordance with the maximum allowable current of the power strip to be used.
- If a peripheral is used, connect it to a receptacle via an insulating transformer. Connect peripherals in accordance with the specification of the insulating transformer.
- Use the multi-tap installed in the cart only for the equipment used for this system. If it is used for other equipment, the current capacity may increase and the equipment may not operate properly.
- Do not install a 700 system scope on the scope connector with the 600 system scope or 500 system scope inserted into the electric connector socket.
- Install equipment in a location in which the power cord or connected endoscope will not become entangled. Equipment may fall over or down, the screen may go black, or the patient or operator may be injured.
- To use this product with peripheral devices, properly connect the input and output terminals as per the products' instructions. Incorrect connections may cause equipment failure.
- Do not block ventilation holes located on the left side and rear panel of this product.

1.2.8 Transferring the equipment

WARNING

- The heavy weight of the processor may cause physical injuries when moving it. Move it using two persons.

1.2.9 Electric Shock

WARNING

- Connect the power plug directly to the protective earth receptacle. Use peripherals that are compliant with the medical safety standards. Not doing so may cause an electric shock.
- Do not simultaneously touch the patient and any of the system devices in the patient environment. Doing so may cause electric shock.
- If the power cords of the peripherals are connected without using the insulation transformer on the cart, the enclosure leakage current may increase, posing a risk of injury or electric shock to the patient and/or the physician when he/she comes into contact with those devices.

CAUTION

- Use the rated voltage only. Not doing so may cause a fire, electric shock or malfunction.

1.2.10 Explosion

WARNING

- Do not use the equipment in atmosphere of flammable gas or oxygen-rich environment. Doing so may cause explosion or fire.

1.2.11 Foreign Matter and Liquid

WARNING

- Foreign matter, water and chemicals entering the equipment may cause a fire or electric shock. In such a case, stop using the equipment immediately, disconnect the power plug from the power outlet, and consult your local FUJIFILM dealer.
- Keep metals except for the endoscope away from the power supply section. Otherwise, metals may generate heat.
- Before connecting the endoscope, ensure that no foreign matter adheres to the scope connector section. If any foreign matter is located within the power supply section, it may cause malfunction or failure of the devices and may also generate heat. If any foreign matter is found, do not touch it directly with your hand but clean equipment as described in this manual after disconnecting the endoscope.
→ "9.1 Care after Use of Processor"

WARNING

- Ensure that there is no foreign matter or dirt on the receiving window or on the communication window before connecting the endoscope. If there is any foreign matter or dirt on the receiving window or on the communication window, it may cause malfunction or failure of the devices.
- Make sure that the scope connector including the power-receiving section is thoroughly dry before connecting it to the light source. In addition, make sure that no moisture or foreign matter (such as metallic fragments, chemical residues, water deposits, grease, dust, and gauze fibers) adheres to the power-receiving section. If the connector mount is wet or soiled with foreign matter, it may cause malfunction or failure of the devices.

1.2.12 High Voltage**CAUTION**

- This product has high voltage portions. No one except service personnel should touch the inside.

1.2.13 Maintenance**CAUTION**

- The equipment will wear out and deteriorate after repeated use over a long period. The equipment is required to be inspected by specialists once every six months. Also, if any abnormality is found during clinical use, carefully withdraw the endoscope from the patient as per instructions provided in the operation manual of the endoscope.
- Do not disassemble or modify the equipment. For details on the inspection, consult your local FUJIFILM dealer.
- This product should not be subjected to any type of repair or maintenance procedure while it is being clinically used on a patient.

1.2.14 Preparation and inspection before use**CAUTION**

- Prior to using this product, prepare a spare one to avoid unexpected accidents such as equipment failure. If a replacement is not available, you may not be able to continue endoscopic procedures.
- Make sure to check the equipment before use according to the procedures provided in this manual, to avoid unexpected accidents, and take full advantage of the equipment's capabilities.
- In particular, errors in images may cause false diagnosis. If the inspection result shows any abnormality, do not use the equipment.

1.2.15 Temperature at distal end

CAUTION

- When the endoscope projects light at high brightness over an extended time, the temperature may exceed 41°C at the distal end. When you hang the endoscope on the cart hanger, turn the light off.

1.2.16 Disposal

CAUTION

- This product has components that contain a lithium manganese dioxide battery and other materials that may cause environmental pollution. Follow the legal procedures when discarding the product. For details, consult your local FUJIFILM dealer.

1.2.17 Security Function

CAUTION

- Once the user logs in to the security function, all the information can be accessed until the user logs off the security function or turns off the system. When stepping away from the system, be sure to log off the security function or turn off the system.
- If you forgot the login password and cannot log in to the security function, consult your local FUJIFILM dealer.

1.2.18 Handling of this equipment

CAUTION

- Do not disassemble or modify this product. Otherwise, the radiant intensity may exceed Class I specifications.
- Clean the equipment in the proper way as specified. Otherwise, the equipment may be damaged.
→ "9.1 Care after Use of Processor"
- Do not wash this product with running water or immerse it in disinfectant. Do not disinfect or sterilize this product. Doing so may cause malfunctions.
- Do not touch electric contact points directly by hand. Do not wipe contact points with any other liquid than alcohol. Doing so may cause corrosion and malfunctions.
- Keep metals except for the endoscope away from the power supply section. Otherwise, metals may generate heat.
- Wear personal protective equipment (such as goggles, facemask, chemical-resistant and waterproof gloves, protective clothing, cap and shoe covers) when handling this equipment to prevent infection and electrostatic discharge.

1.2.19 Potential equalization

- This system is equipped with an equipotential terminal. Use this terminal when equipotential grounding is required at the hospital or clinic.

1.2.20 System Version

- Software is used to control this product. Therefore, the control method differs depending on the version of the software being used. This operation manual describes operations of System Ver.1.000 to 1.099 and EX-CAD V1.0 to 1.99. The version is shown under the heading "Software" displayed on the screen by pressing the [Shift] and [Note] keys at the same time.

1.2.21 Electromagnetic interference

This product generates, uses and can radiate electromagnetic energy. To prevent electromagnetic interference within the vicinity of this product, read the following precautions and properly handle this product and other devices in the vicinity.

Install and use this product according to "Electromagnetic Compatibility (EMC) Information" in Appendix.

WARNING

- Do not use this product adjacent to or stacked with other equipment. If such use is necessary, this product and the other equipment should be observed to verify that they are operating normally. Failure to do so could result in improper operation.
- Do not use portable and mobile RF communications equipment closer than 30 cm to any part of this product. Otherwise, degradation of the performance of this product could result.
- Use the cable specified in the Operation Manual. Use of other cables may cause an increase in electromagnetic emission or decrease in electromagnetic immunity of this product.

CAUTION

- Use this product in the specified environment and with specified methods. Otherwise, unintended images (such as a rotated or inverted observation image or a screen other than the observation screen) may be displayed or the light may not be emitted properly.
- This equipment has been tested and found to comply with the limits for medical devices defined in EN 60601-1-2:2015. These limits are designed to provide reasonable protection against harmful interference in a typical installation at professional healthcare facilities such as hospitals and clinics. However, it is possible that it may cause harmful interference to other devices in the vicinity, if it is installed and used in accordance with the instructions. Also, there is no guarantee that interference will not occur in a particular installation. Therefore, if this equipment does cause harmful interference to other devices, which can be determined by turning the equipment off and on, the user is encouraged to try to correct the interference by one or more of the following measures:
 - Change the orientation or position of any affected device.
 - Increase the spacing between devices.

- Consult the manufacturer or dealer of the device.

Noise may appear on the monitor of this equipment due to the effect of electromagnetic waves. In this case, turn off the device emitting the electromagnetic waves or move the device away from this equipment.

- Do not use this product near devices that generate strong electromagnetic waves, such as MRI systems. Doing so may cause malfunction of this product.
- If this product is used in combination with an electrosurgical unit, follow the instructions provided in the operation manuals of the electrosurgical unit and high-frequency endotherapy device.

1.2.22 Using This Product by Connecting to Equipment (EX-WS) with EW1 System Software

CAUTION

- When this product is used by connecting to the EX-WS, connect the monitor to each of the EX-WS and this product.
- On the monitor connected to the EX-WS, an indication is displayed, showing that the image is displayed via the EW1 System Software. For details on the indication, refer to the operation manual of the EW1 System Software.
- When the setup screen for the EX-WS is displayed, "Displaying EX-WS Menu" is displayed on the monitor connected to this product.

2.1 Checking Package Components

Check the components in the package against the items shown in the figures below. Inspect each component for damage. If a component is damaged, or if a component is missing, contact your local FUJIFILM dealer.

◆ Package Components

Note

- The type of the data keyboard varies depending on the country.
- The figure in parentheses indicates the quantity.

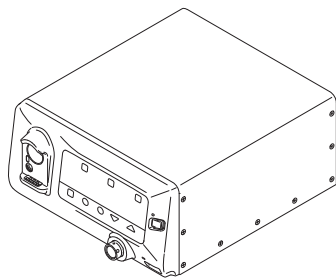

Processor
EP-6000 (1)



Socket Protection Cap
CC-203 (1)

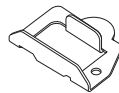

LAN connector guard (1)

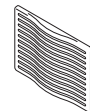

Louver (1)
Dustproof filter (1)

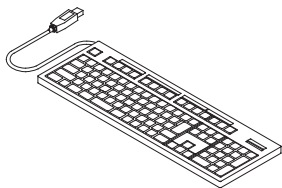

Data Keyboard
DK-6000U (1) or DK-6000E (1)

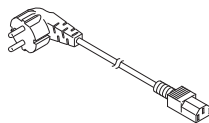

Power Cord (1)

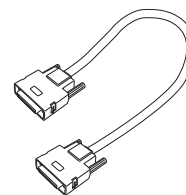

WC-LINK cable (1)

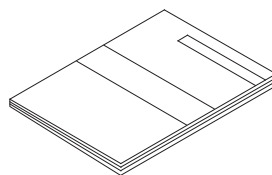

Operation Manual (1)

2.2 Equipment Using in Combination

The equipment used in combination with this product is shown in the table below.

Table 2.1 Equipment configuring the standard system

Type	Model name	
Processor	EP-6000	
Data Keyboard	DK-6000U or DK-6000E ^{*1}	
Endoscope ^{*2}	600 system scopes, 500 system scopes ^{*3}	700 system scopes
Water Tank	WT-4	WT-603
LCD Monitor ^{*4}	CL-22, CL-24, CCL220/AR, CCL244/AR	

*1 The type of the data keyboard varies depending on the country.

*2 The Image enhancement function (special-light observation mode: BLI/BLI-bright/LCI, FICE) that can be used depends on the endoscope model.

➔ "7.10 Switching Observation Mode"

➔ "7.12 Turning On/Off FICE"

*3 Excluding 590 series scope, EG-530UT2, EG-530UT, EG-530UR2 and EG-530UR.

*4 CL-22 : Model name

CL22220-FFCL22

CL-24 : Model name

CL24244-FFCL24

CCL220/AR : Model name

CL22220-W1WD0J, CL22220-W1WD0E, CL22220-W1WD0U, CL22220-W1WD0C

CCL244/AR : Model name

CL24244-W1WD0J, CL24244-W1WD0E, CL24244-W1WD0U, CL24244-W1WD0C

Table 2.2 Medical equipment which can be used for expanding the system

Type	Model name
Ultrasonic Processor	SU-1, SP-900
Printer	UP-25MD (SONY) ^{*1} , UP-55MD (SONY), UP-D25MD (SONY)
Video Recorder ^{*1}	HVO-3300MT (SONY) ^{*2} , HVO-1000MD (SONY) ^{*2} , HVO-550MD (SONY)

*1 This equipment cannot use the RS-232C connector or digital printer connector of this product for the connection.

*2 Recording is not possible with the RGB TV terminal output signal of this product input to the RGB IN terminal.

Note

- For equipment not listed in this document, such as the carbon dioxide gas feeding equipment and water supply equipment for the endoscope, see the operation manual of the endoscope.
- Some of these products may not be available in your country or region. Please contact your local FUJIFILM dealer for availability of these products.

Table 2.3 Medical device software which can be used for expanding the system

EW1 System Software	
Endoscopy support program	EW10-EC Group Software

Note

- The availability of the EW1 System Software varies depending on the country. For details, consult your local FUJIFILM dealer.
- To use the EW1 System Software, settings by service personnel is required.

2.3 Standard System Configuration

The standard system configuration is the minimum configuration required for general endoscopy. Observation (diagnosis) and biopsy can be performed on the monitor.

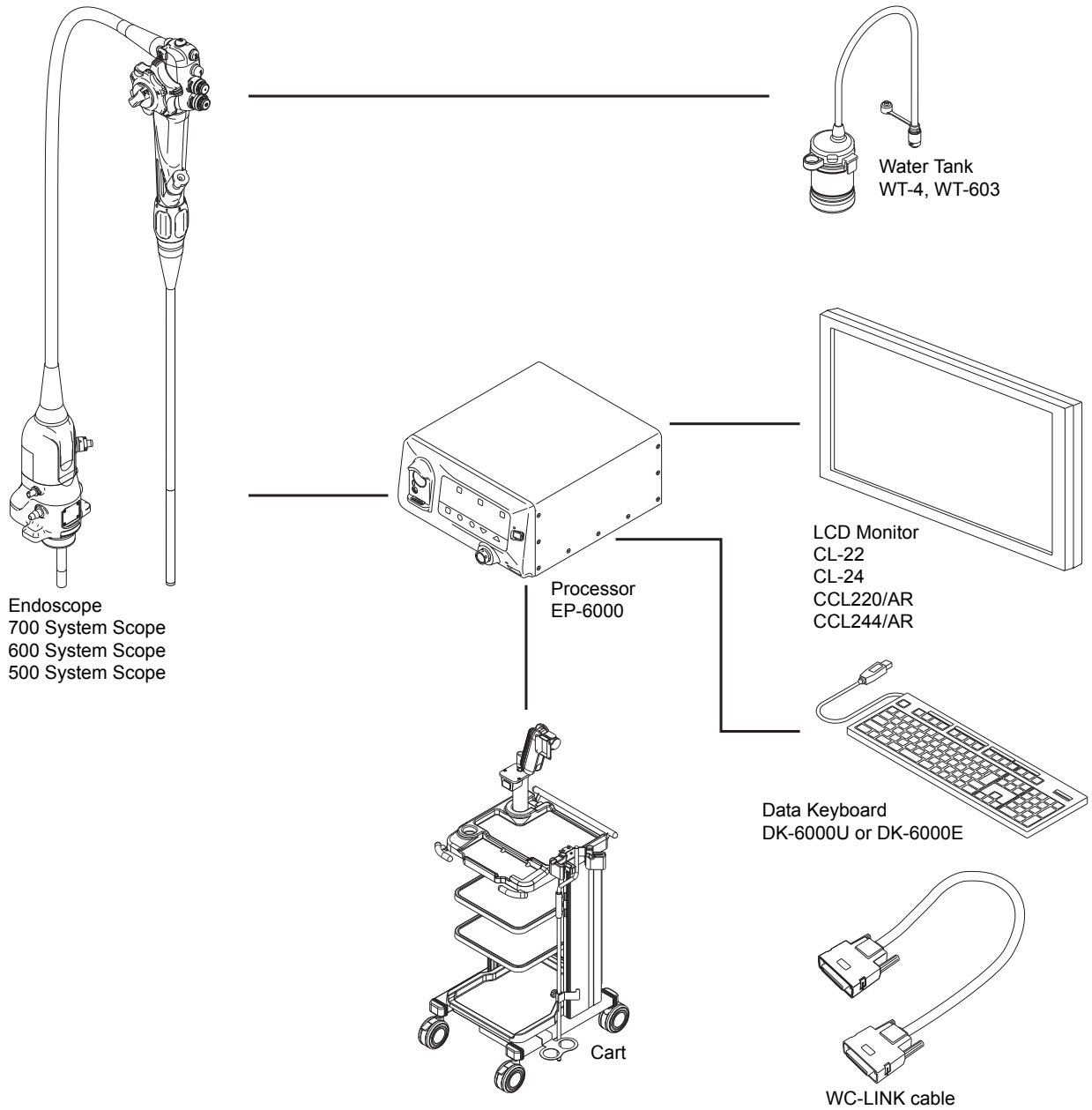

2.4 System Expansion

This system can be extended by connecting various peripherals to the standard system configuration. Extension makes the following possible.

- Endoscopic treatment
- Ultrasonic examination
- Recording of video images
- Printing of still images

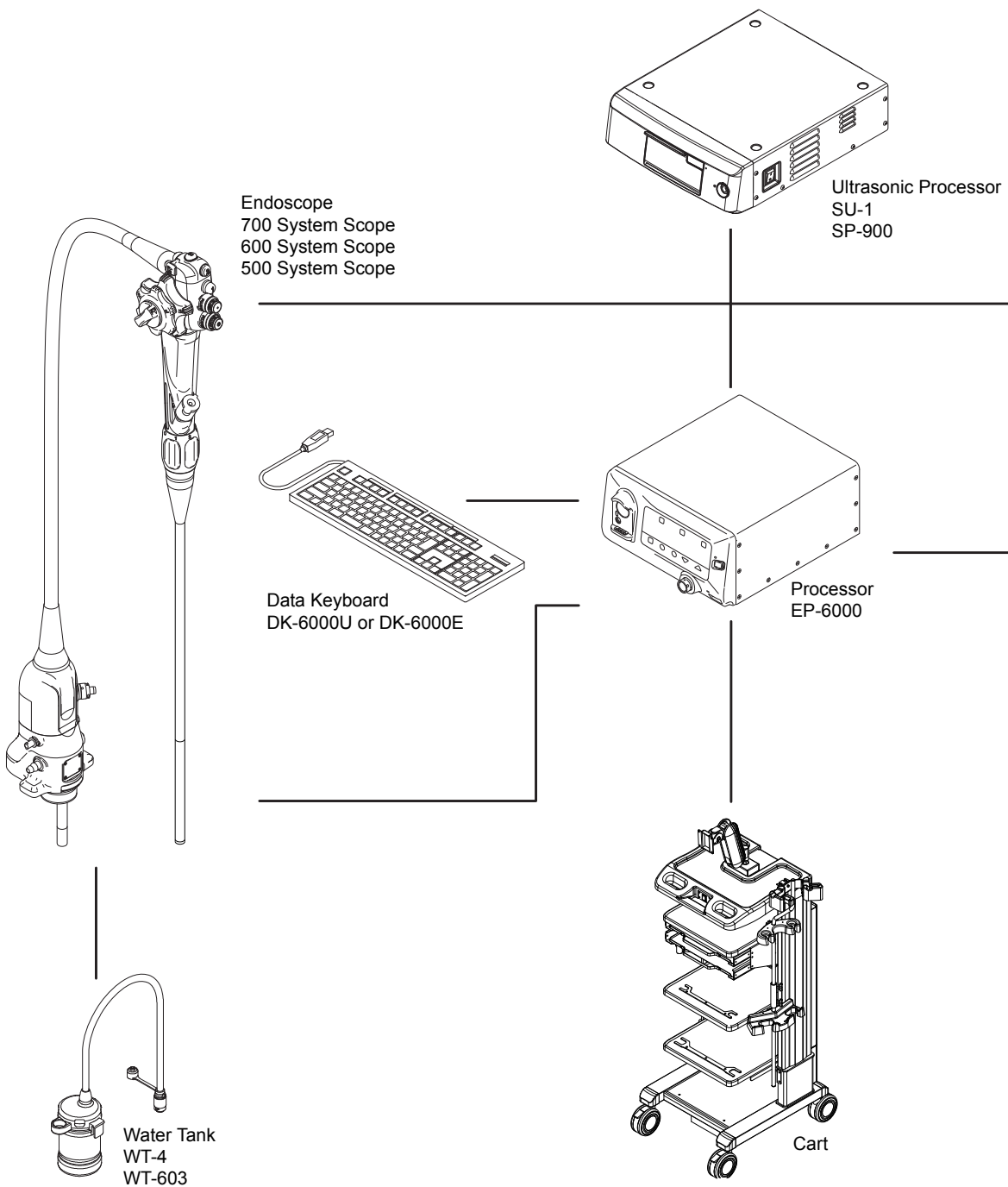

Note

- For details on the connections of peripherals other than listed here, consult your local FUJIFILM dealer.

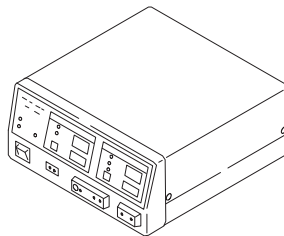

Electrosurgical Unit

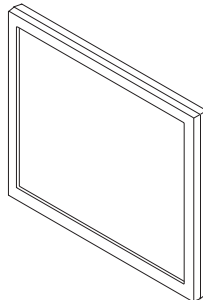
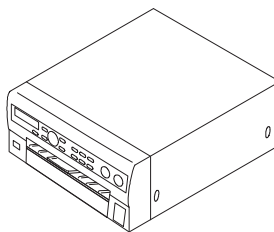
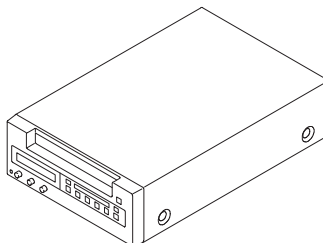
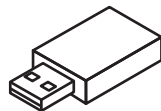
LCD Monitor
CL-22 (FUJIFILM)
CL-24 (FUJIFILM)
CCL220/AR (JVC KENWOOD)
CCL244/AR (JVC KENWOOD)Printer
UP-25MD (SONY)
UP-55MD (SONY)
UP-D25MD (SONY)Video Recorder
HVO-3300MT (SONY)
HVO-1000MD (SONY)
HVO-550MD (SONY)

EW1 System Software

Name and Function of Each Part

3.1 Front Panel

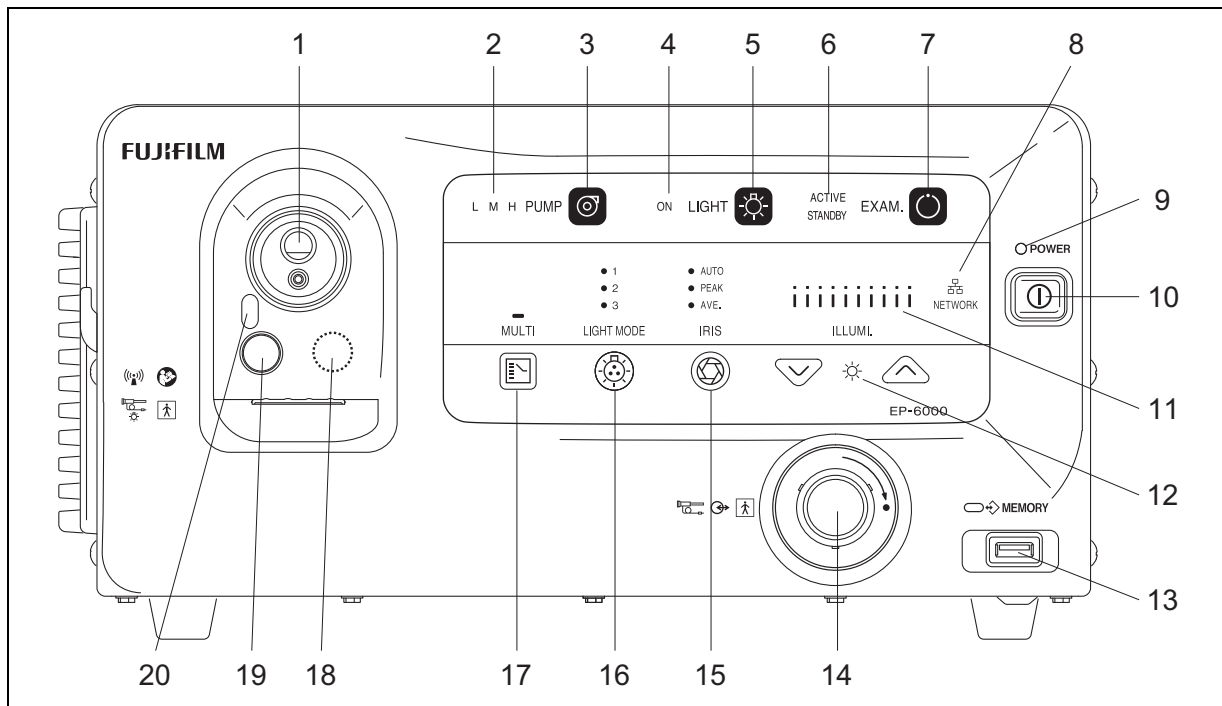

1. Scope Connector Socket

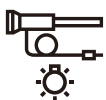

Accepts the scope connector or LG connector of the endoscope.

2. Air Supply Indicator

L M H

Displays an air supply pump level of “H (high)”, “M (mid)” or “L (low)”.

3. Pump Button



Switches the air supply amount to “H”, “M”, “L” or OFF.

4. ON Indicator

ON

This indicator lights up when the light is turned on.

5. Light Button



Turns on/off the light.
 ON: Lights up in blue.
 OFF: Lights up in orange.

6. EXAM. Indicator Lamp

ACTIVE
 STANDBY

Power to the Endoscope ON:
 The ACTIVE indicator lamp lights up in blue.

Power to the Endoscope OFF:
 Press and hold the EXAM. button for about 2 seconds.
 While the STANDBY indicator lamp is flashing in orange, do not remove the endoscope.
 When the STANDBY indicator lamp lights up in orange, the endoscope can be removed.

Note

- In order to turn OFF the endoscope, press and hold the EXAM. button for about 2 seconds. While the STANDBY indicator lamp is flashing in orange, do not remove the endoscope before this lamp lights up.

7. EXAM. Button



Used to turn the power to the endoscope ON and OFF.

8. Network Access Indicator Lamp



Displays the connection status of the network.

- During connection: Lights up in green.
- During communication: Flashes in orange.
- When the communication fails: Lights up in orange.

9. Power Indicator Lamp



Lights up when the power is ON.

10. Power Button



Used to turn the power supply ON/OFF.

11. Indicator



Indicates the light intensity when the light is turned on.
 When the brightness adjustment button is pressed, this indicator displays the level of brightness to be used as a standard.

12. Brightness Adjustment Button



Adjusts the level of the automatic light control.

13. Memory Slot/Memory Access Lamp

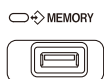

Used for connecting the external storage device.

→ “5.4.2 Memory Tab”

→ “8.8 Copying Images to External Storage Device”

14. Electrical Connector Socket

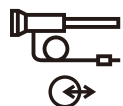

Used to connect the electrical connector of the 600 system scope or 500 system scope.

15. Iris Mode Button



Used to switch the iris mode between AUTO, PEAK, and AVE.

→ “7.15 Switching the Iris Mode”



16. Light Mode Button



Switch Observation mode to “1”, “2”, “3” or OFF.

→ “7.10 Switching Observation Mode”

17. MULTI Button



The desired function can be assigned to this button.

Default setting: Light Limit

→ “4.2.3 Function Tab”

18. Power Supply Section

Supplies power to the endoscope.

19. Receiving Window

Receives data from the endoscope.

20. Communication Window (LED)

Performs information communication with the endoscope.

3.2 Rear Panel

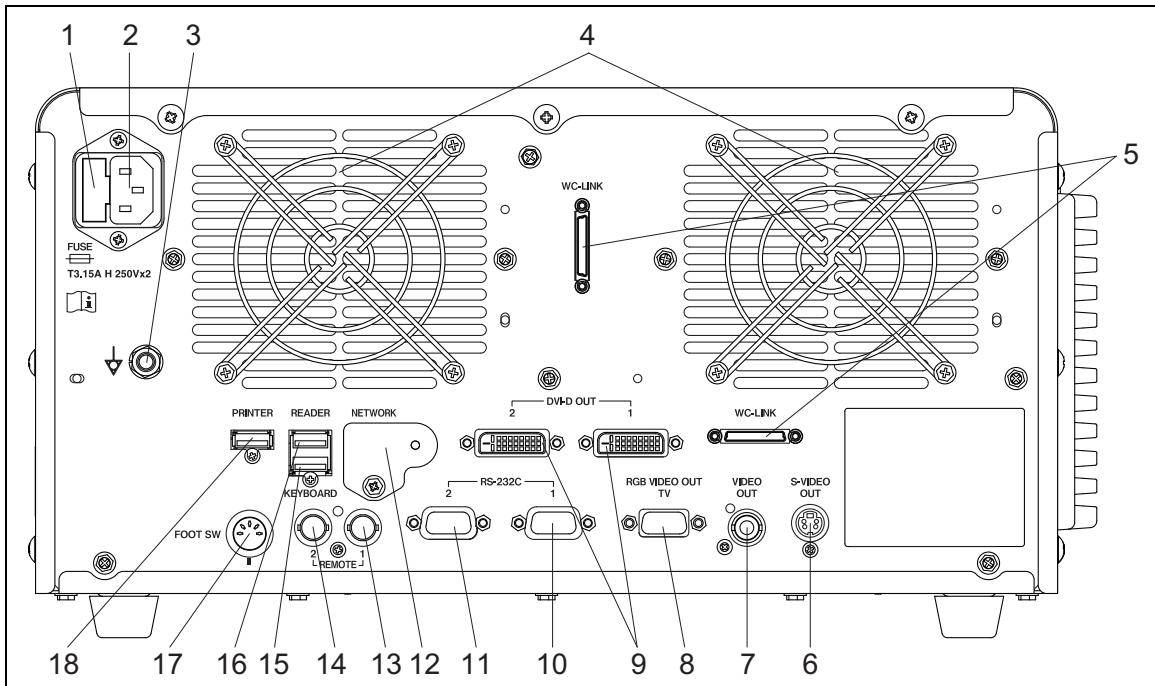

1. Fuse Holder

 Contains two T3.15AH 250V fuses.

2. Power Supply Connector

Used to connect the attached power cord.

3. Potential Equalization Terminal

 When necessary for safety, this terminal is connected to a potential equalization terminal on a peripheral device to equalize the potential between this product and the peripheral device.

4. Ventilation Holes

Provide ventilation to keep the inside of the equipment cool.

5. WC-LINK cable terminal

A terminal to connect by using a WC-LINK cable.

6. S Video Connector

Outputs a component signal separated into a Y signal for brightness and a C signal for color.

7. Video Connector

Outputs a composite video signal.

8. RGB TV Connector

Outputs the video signals of R, G, B, and SYNC.

9. DVI-D Connector

Used to connect the LCD monitor via a monitor cable. Digital image signals are output from this connector.

10. RS-232C Connector 1

Connector used for communication with a peripheral device connected with the RS-232C interface.

11. RS-232C Connector 2

Connector used for communication with a peripheral device connected with the RS-232C interface.

12. Network Connector

Used to connect to the network.

Note

- Remove the metal plate before using this terminal and install with LAN connector guard.

13. Remote Connector 1

Outputs a trigger signal to control peripherals. When the trigger or recording function is activated with the scope switch or foot switch, the corresponding signal is output.

14. Remote Connector 2

Outputs a trigger signal to control peripherals. When the trigger or recording function is activated with the scope switch or foot switch, the corresponding signal is output.

15. Keyboard Connector

Used to connect to the data keyboard DK-6000U or DK-6000E.

16. Reader Connector

Connect a reader.

17. Foot Switch Connector

Used to connect the foot switch FS1.

18. Digital Printer Connector

Used to connect a digital printer.

3.3 Side Panel

<Left side>

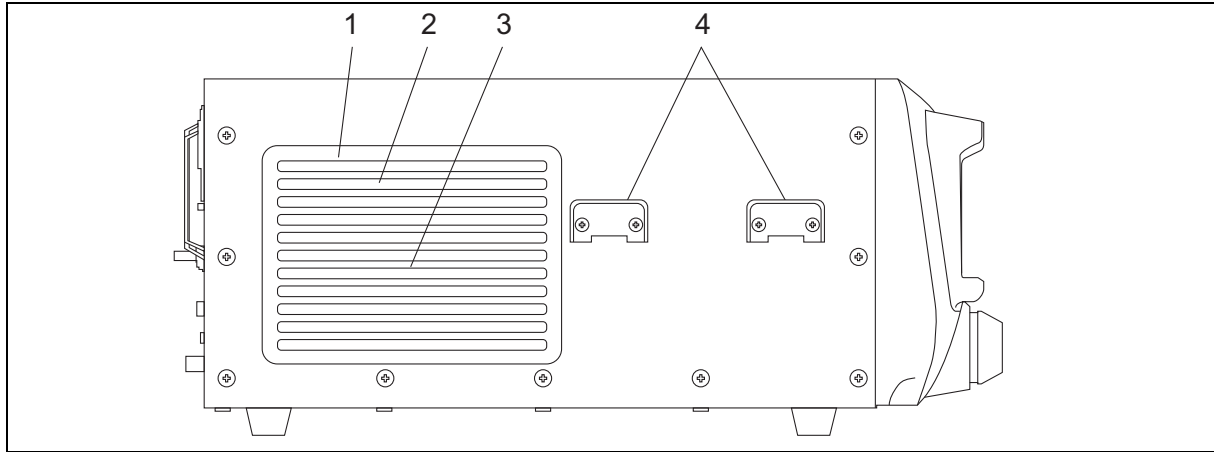

1. Louver
Sets the dustproof filter.
2. Dustproof Filter
The filter prevents the intrusion of dust.
3. Ventilation Holes
Ventilation holes. Keep holes 100mm or more away from any objects.
4. Water tank hook
Mount the water tank on this hook.

3.4 Keyboard

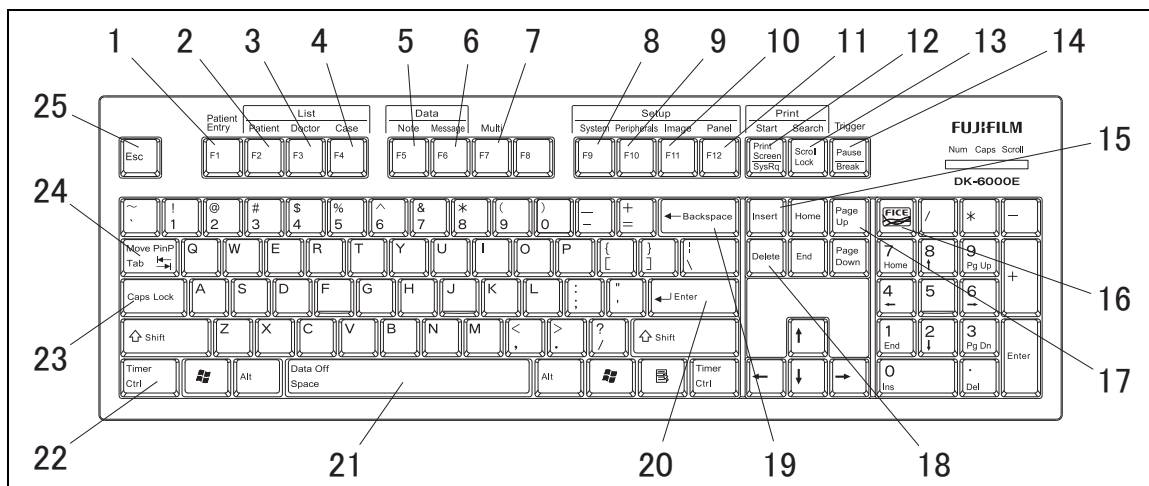

<Data control keys>

1. [Patient Entry] key
Displays the Patient Information Entry screen.
2. [Patient] key
Displays the Patient List screen.
3. [Doctor] key
Displays the Doctor List screen.
4. [Case] key
Displays the Procedure List screen.
5. [Note] key
Makes it possible to enter comments on the observation screen.
6. [Message] key
Displays the Message List screen.
7. [Multi] Key
A function can be assigned.
→ “4.2.3 Function Tab”

<Peripheral device control keys>

8. [System] key
Displays the System Setup screen.
9. [Peripherals] key
Selects and performs the settings for the peripheral devices to be used with this product.
10. [Image] key
Displays the Image Setup Page screen.

11. [Panel] key

Performs the initial settings for the functions assigned to the front panel of this product.

12. [Start] key

Starts printing the data displayed in the print preview screen.

13. [Search] key

You can search for or review images stored in the main unit.

14. [Trigger] key

While a still image is displayed in the normal observation screen, pressing this key captures the image.

Note

- When a still image is not displayed, no image is captured even if this key is pressed.

<Other keys>

15. [Insert] key

Edits the character or data at the cursor position.

- (1) When a list of patient data is displayed : Displays the edit screen for the selected patient data.
- (2) When a list of doctor names is displayed : Edits the selected doctor name.
- (3) When a list of procedure names is displayed : Edits the selected procedure name.

16. [FICE] key

Turns on or off FICE.

17. [PageUp] key

When the observation screen is displayed and FICE is turned "ON", pressing this key displays the current FICE set.

➔ "3.10 Displaying FICE Set"

18. [Delete] key

Deletes the character at the location of the cursor.

- (1) When a list of patient data is displayed : The selected patient data is deleted.
- (2) When a list of doctor names is displayed : The selected doctor name is deleted.
- (3) When a list of procedure names is displayed : The selected procedure name is deleted.

19. [Backspace] key

Deletes the character located immediately before the cursor.

20. [Enter] key

If you press this key after entering data, the entered data is finalized.

Also, if you press this key while a message is displayed in the observation screen, the message disappears.

Also, if you press this key while the thumbnail display screen is displayed, the image at the location of the cursor is enlarged.

21. [Data Off/Space] key

Each time you press this key while the observation screen is displayed, the data on the observation screen switches between a displayed and a non-displayed state. In addition, this key is used for selecting images to be printed in the print preview screen.

Note

- When “Data Display Switching” is disabled, the function of this switch is also disabled. (“Data Display Switching” is set by service personnel.)
- This key is described as the [Space] key in the operation manuals of this product.

22. [Timer Ctrl] key

Starts/stops the timer on the observation screen.

Note

- This key is described as the [Ctrl] key in the operation manuals of this product.

23. [Caps Lock] key

Each time you press this key, the alphabet is toggled between upper and lower case.

24. [Move PinP/Tab] key

When the output resolution is set to “SXGA”, the mask type is set to “Type 1” and the sub-screen is displayed in the observation screen, the position of the sub-screen is changed in the order of upper left, upper right, lower right and lower left each time this key is pressed.

Note

- This key is described as the [Tab] key in the operation manuals of this product.

25. [Esc] key

If you press this key while entering data, operation returns to the previous screen or observation screen.

3.5 Socket Protection Cap

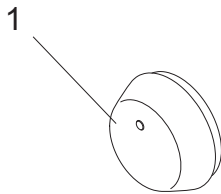

1. Socket Protection Cap for Electrical Connector

Covers the socket when the 600 system scope or 500 system scope is not connected.

Note

- Whenever the 700 system scope is used, attach the protection cap.



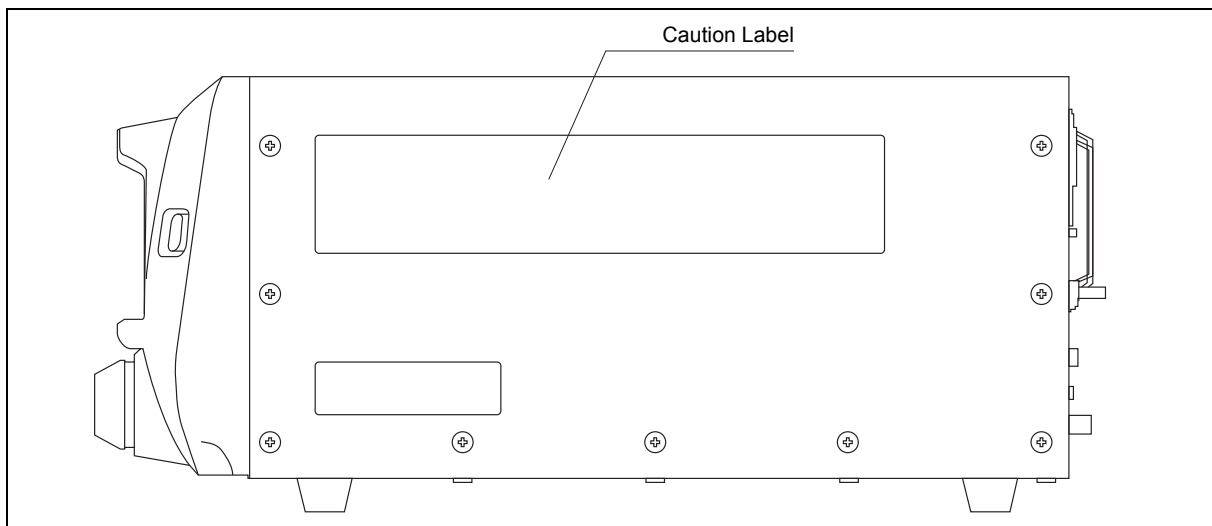



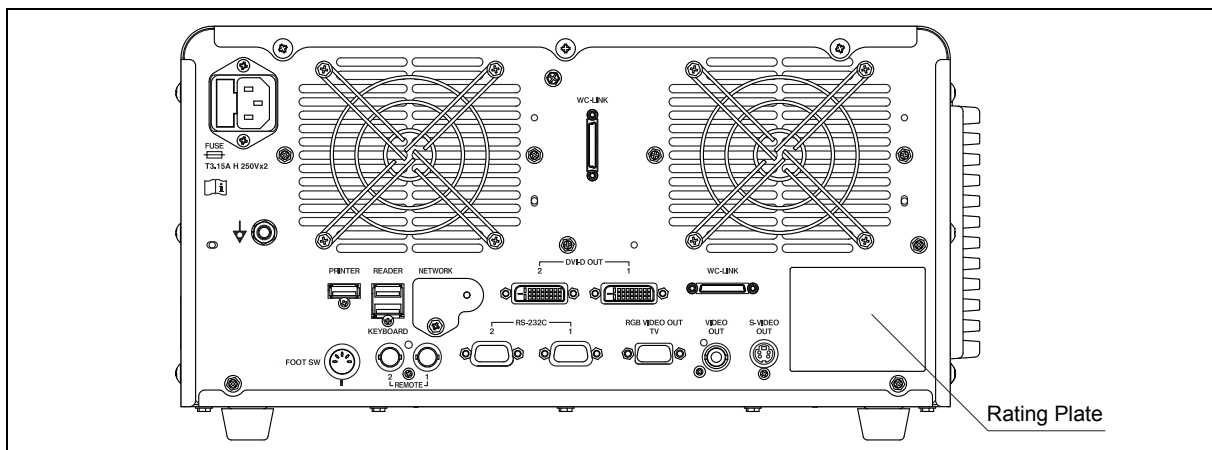











3.6 Caution Label



3.7 Rating Plate



3.8 Symbols

Symbol	Description
	Serial number
	Date of manufacture
	Manufacturer
	Authorized representative in the European Community
	Consult instructions for use
	Temperature limitation
	Keep dry
	CE marking
	Type BF applied part
	WEEE marking *
	Humidity limitation
	Atmospheric pressure limitation
	Alternating current
	Fuse
	Potential equalization terminal
	Consult instructions for use
	RF electromagnetic energy
	Scope Connector Socket
	Electrical Connector Socket

* This product shall not be treated as household waste.

3.9 Data Display on the Observation Screen

Three types of special-light observation mode can be used in addition to normal light observation mode (“Normal mode”).

Observation modes using special light are called “BLI”, “BLI-bright” and “LCI”. On the monitor, they are displayed as “BLI”, “BLI-brt” and “LCI”, respectively.

<Type of the observation screen (Mask Type: Type 1)>

- SXGA mode

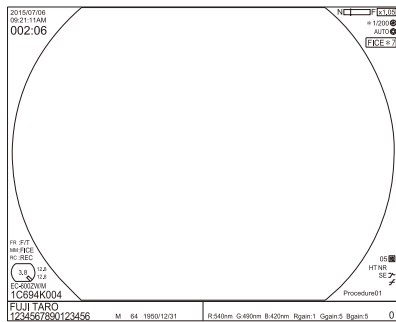

- Full HD mode

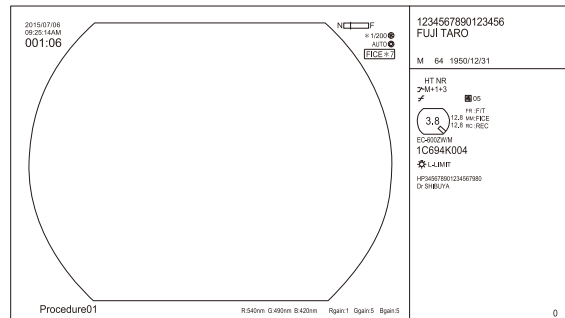

<Type of the observation screen (Mask Type: Type 2)>

- SXGA mode

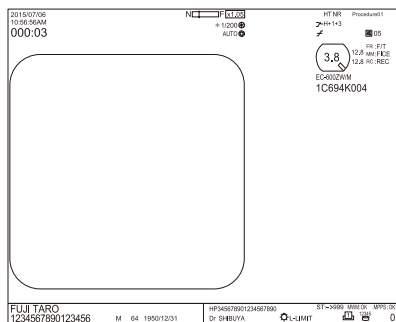

- Full HD mode

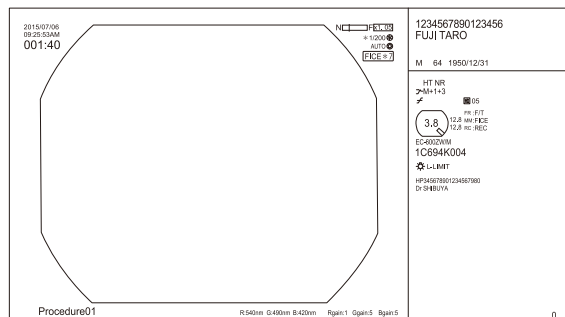

The observation screen is frozen while the scope switch to which the Freeze function is assigned is pressed. While the screen is frozen, the video image is displayed in the sub-screen. When Mask Type: Type 1 is selected in SXGA mode, each pressing of the [Tab] key changes the display position of the sub-screen in order of the upper left → upper right → lower right → lower left.

- SXGA mode

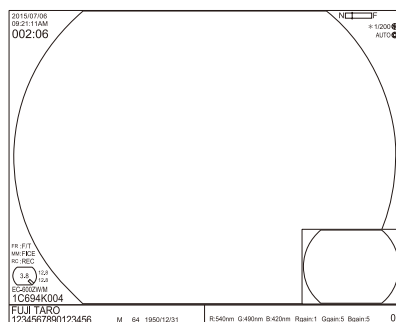

- Full HD mode

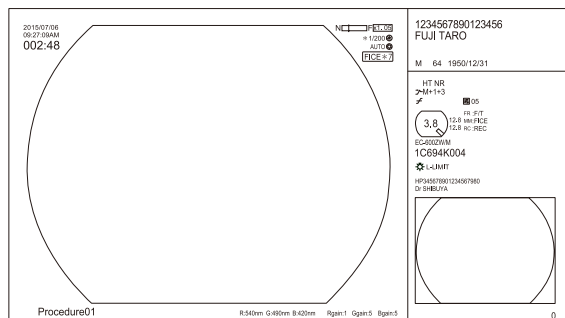

<Type of the observation screen (Mask Type: Type 2)>

• SXGA mode

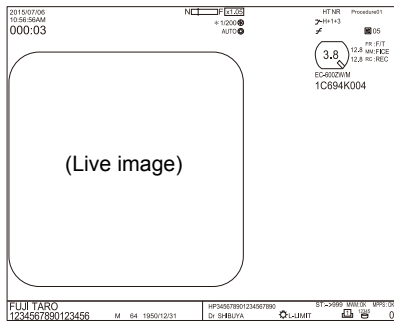

When a live image is displayed

• Full HD mode

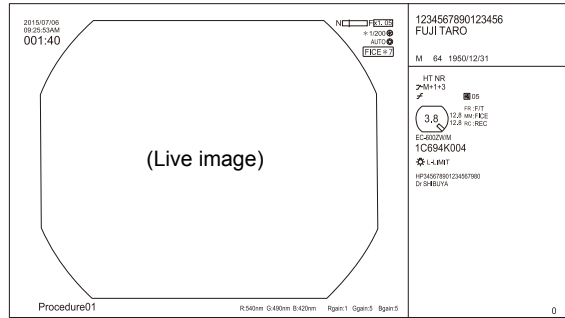

• SXGA mode

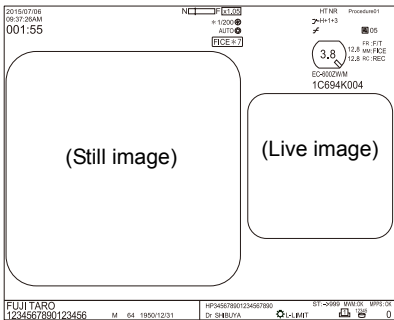

• Full HD mode

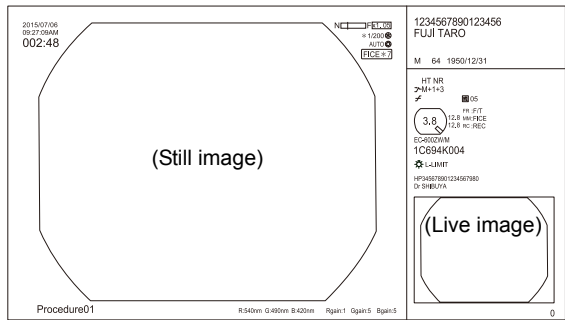

If the scope switch to which freeze has been assigned is pressed, a still image is displayed on the main screen and live image is displayed on the sub-screen.

<Information displayed on the observation screen (Mask Type: Type 1)>

Data to be displayed is different depending on the settings. Setting the data to be displayed should be performed by service personnel.

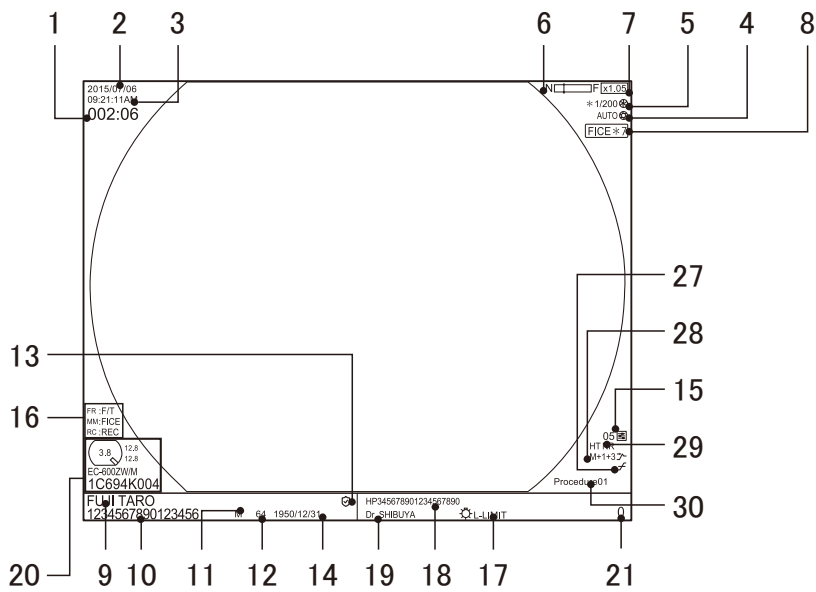
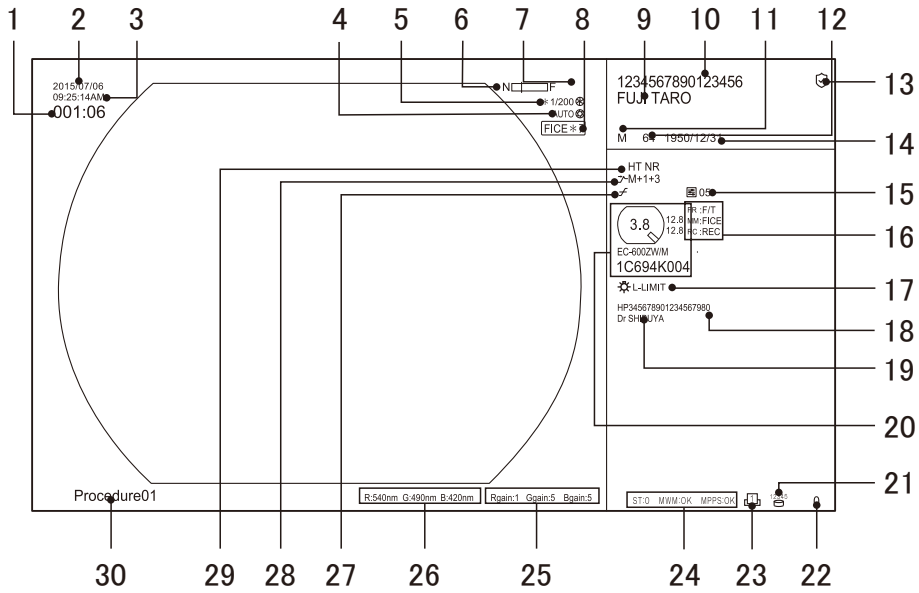

<Information displayed on the observation screen (Mask Type: Type 2)>

Data to be displayed is different depending on the settings. Setting the data to be displayed should be performed by service personnel.

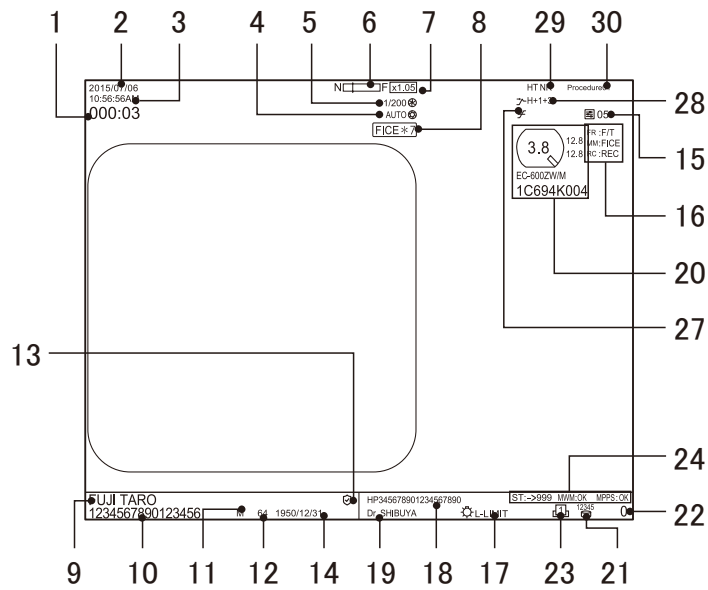
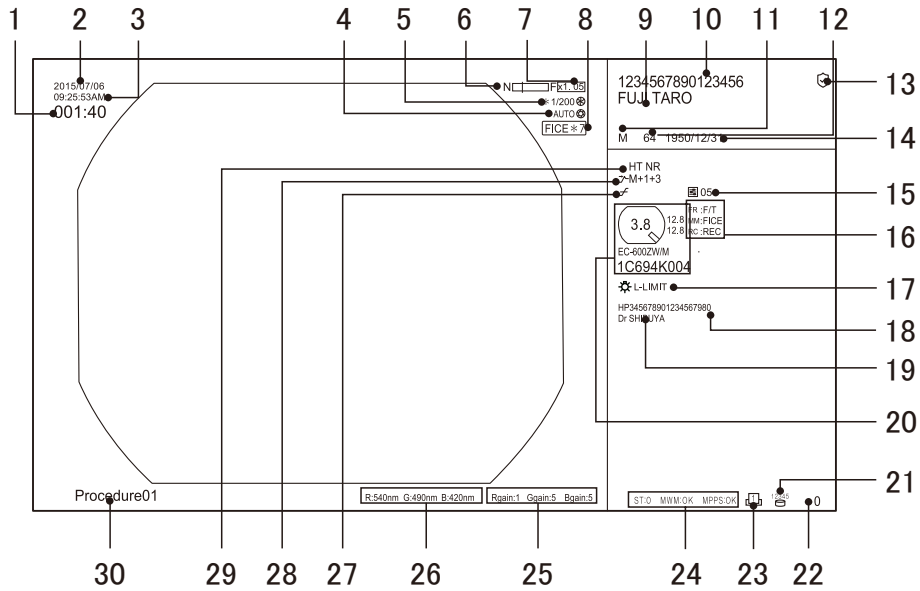

1. Timer
2. Date
3. Time
4. Iris Mode

→ "7.15 Switching the Iris Mode"

5. Shutter Speed

→ “7.14 Switching the Shutter Speed”

6. Focus Indicator

Displayed when an optical zoom scope is connected.

7. Electronic Zoom Ratio

x1.00 to 2.00 or x1.00 to 1.75 (0.05 step)

Note

- The zoom ratio of some 530 series scopes is x1.00 to 1.95.

8. Special Light Observation Mode or Spectral Image Processing function

In special light observation mode, “BLI”, “BLI-bright” or “LCI” is displayed.

With the spectral image processing function, “FICE” is displayed.

9. Patient Name

10. Patient ID or Examination No.

Whether to display the patient ID or the examination No. should be specified by service personnel.

11. Sex

12. Age

13. Login

Displayed when the user logs in to the system.

→ “4.3 Security Function”

14. Date of Birth

15. Image Setup Page

16. Switch Setting

The function assigned to the scope switch is displayed.

→ “4.2.7 Endoscope Tab <Functions to be assigned to the scope switch>”

17. Light Limit

Displays the status of Light Limit

“L-LIMIT” appears on the monitor screen when pressing the multi button on the front panel to turn on the Light Save Function.

→ “7.9 Light Save Function”

18. Hospital Name

19. Doctor Name

20. Scope Information

The scope type or scope serial, minimum diameter of instrument channel, outer diameter of distal end, and outer diameter of insertion tube are displayed.

Scope information may not be displayed depending on the connected scope.

→ “3.11 Patient Info. + Scope Info. Dialog”

21. Number of Recordable Images in Internal Storage Device

The display flashes while the internal storage device is accessed. Do not turn off the power while the display flashes.

22. Number of Captured Images

23. Printer Status

The status is displayed as follows (only for digital printer):

When the printer is used: 

Memory status:  to 

When the printer is not used: Nothing is displayed.

24. DICOM Server Connection Status

The connection status with the DICOM server is displayed as follows:

S: Storage status of a (stored) image

M: Connection status of the worklist

P: MPPS (progress of an examination)

25. R, G and B Gain Levels

26. R, G and B Components

27. Tone

→ “7.13 Turning On/Off the Tone”

28. Structure Emphasis

→ “7.11 Turning On/Off Structure Emphasis”

29. Hyper-Tone and Noise Reduction

Hyper-tone (HT) and noise reduction (NR) are displayed as follows. (The setting is indicated in parentheses.)

Not displayed (no setting), white (Low), green (Mid), and yellow (Hi)

Installation should be performed by service personnel.

30. Procedure or Comment

<Example of information displayed on the video output screen>

Note

- When the monitor is connected to the RGB TV, Video, or S Video connector, do not use such an image for the main observation.
- Depending on the monitor type, the periphery of the screen may not be displayed. In this case, set the monitor in the under scan mode.

In the case of Normal mode:

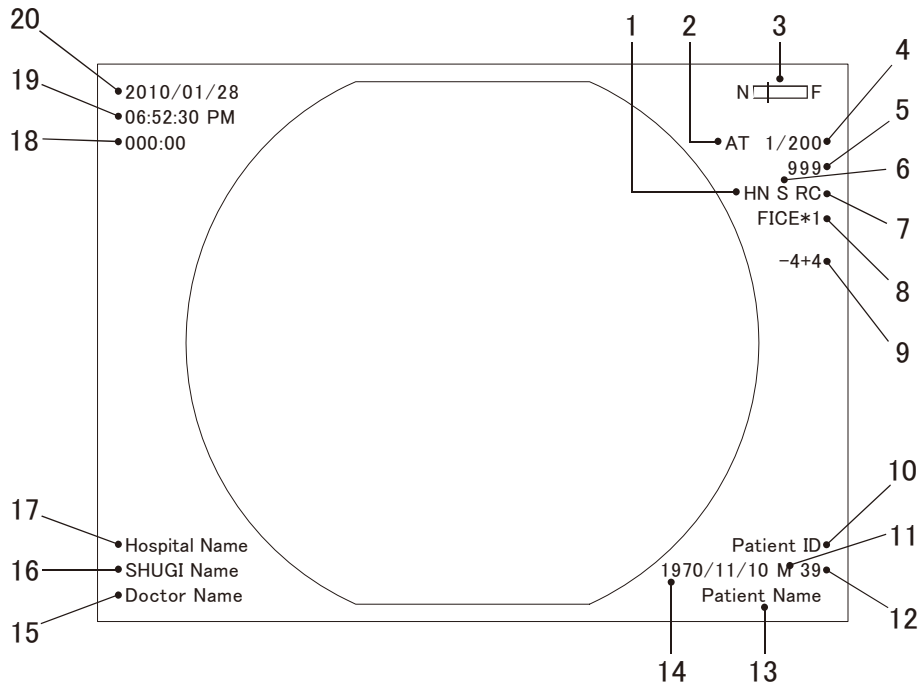

In the case of BLI, BLI-bright or LCI:

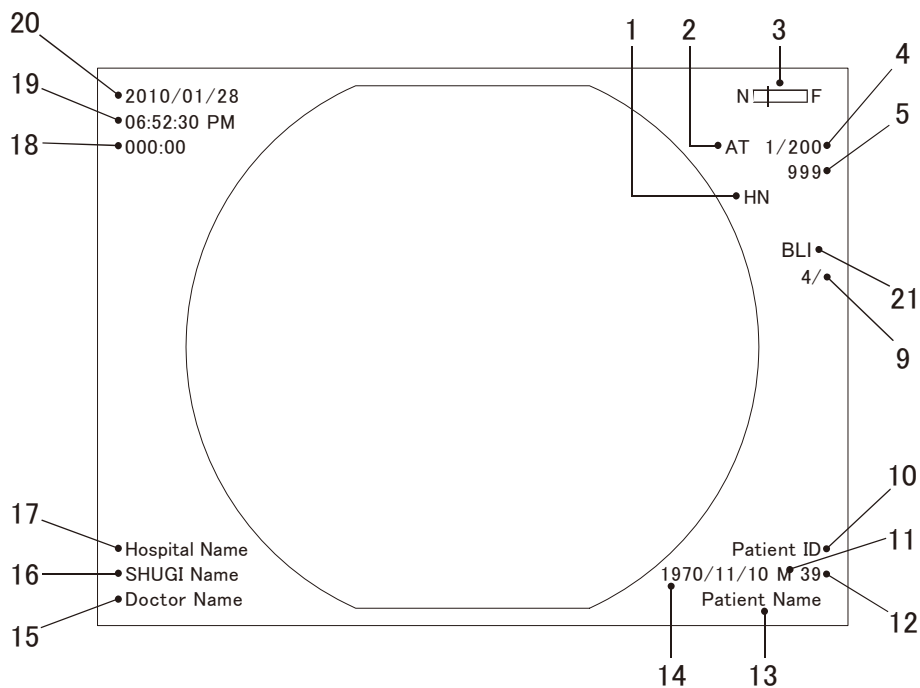

1. Hyper-Tone and Noise Reduction

Hyper-tone (HT) and noise reduction (NR) are displayed as follows. (The setting is indicated in parentheses.)

Not displayed (no setting), white (Low), green (Mid), and yellow (Hi)

Installation should be performed by service personnel.

2. Iris Mode

→ “7.15 Switching the Iris Mode”

3. Focus Indicator

Displayed when an optical zoom scope is connected.

4. Shutter Speed

→ “7.14 Switching the Shutter Speed”

5. Shooting Counter

6. Structure Emphasis

→ “7.11 Turning On/Off Structure Emphasis”

7. Tone

→ “7.13 Turning On/Off the Tone”

8. FICE

Spectral image processing function (FICE)

Note

- In the BLI, BLI-bright or LCI mode, FICE is not available.

→ “7.12 Turning On/Off FICE”

9. Contour Emphasis

→ “7.11 Turning On/Off Structure Emphasis”

10. Patient ID or Examination No.

11. Sex

12. Age

13. Patient Name

14. Date of Birth

15. Doctor Name

16. Procedure or Comment

17. Hospital Name

18. Timer

19. Time

20. Date

21. Special Light Observation Mode

“BLI”, “BLI-bright” or “LCI” is displayed.

3.10 Displaying FICE Set

When the [PageUp] key is pressed with FICE turned ON, FICE set is displayed on the screen.
By pressing the [PageUp] key again, FICE set disappears.

In the case of SXGA mode:

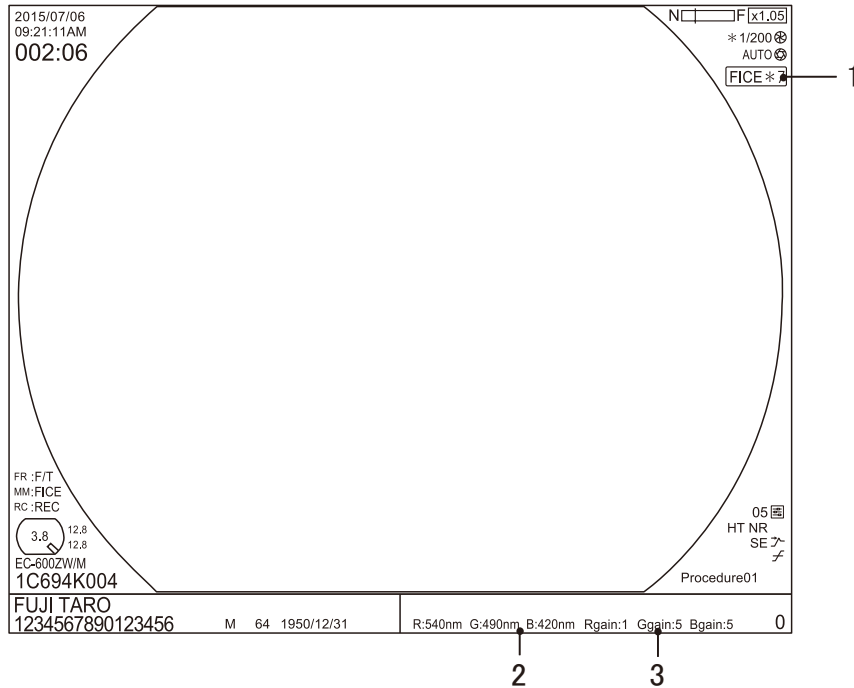

In the case of Full HD mode:

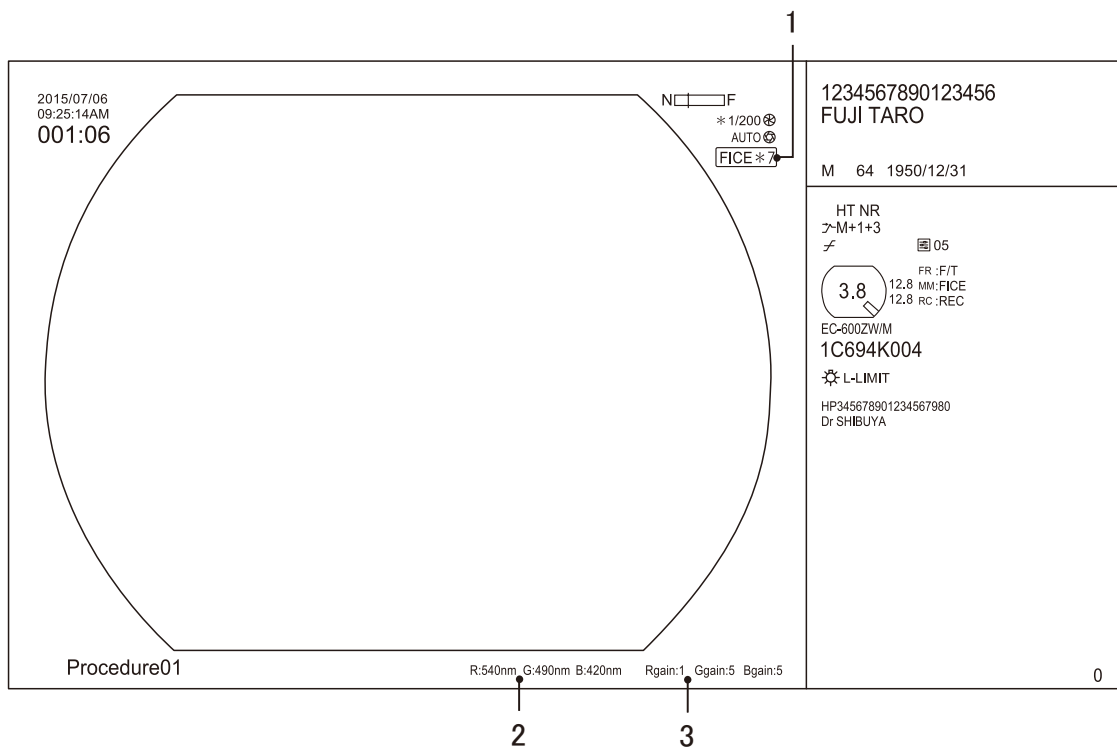

When the monitor is connected to the RGB TV (NTSC/PAL), Video, or S Video connector:

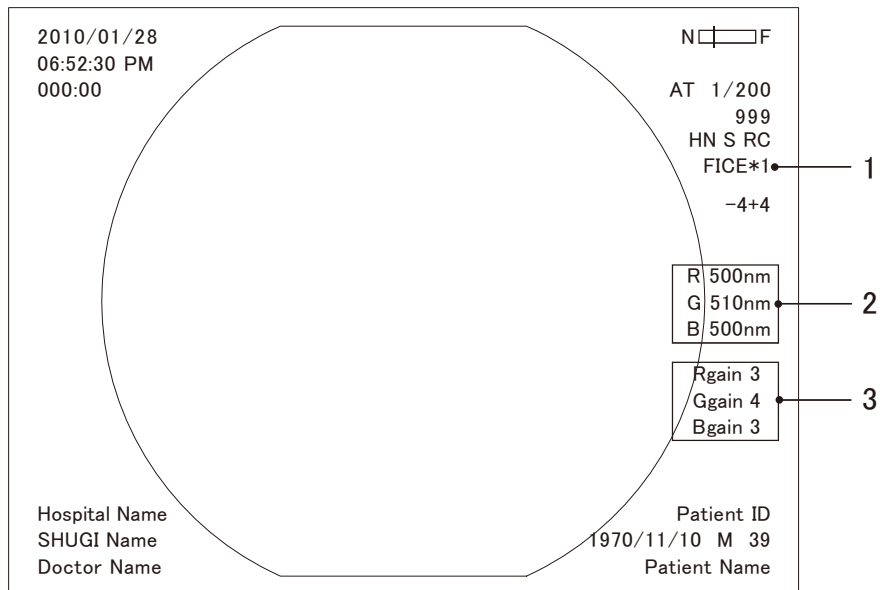

1. FICE set

A FICE set consists of specific wavelengths that are assigned to each R, G and B wavelength and setting values for each gain level (R gain, G gain and B gain).

2. R, G and B Wavelengths

The specific wavelength that is assigned to each R, G and B component can be set between 400 nm and 695 nm in 5-nm increments.

→ “5.3.3 Setting FICE”

3. RGB gain level

Adjusting the intensity of the R, G and B wavelengths can change the display colors. Each gain level for R, G and B can be changed from 1 to 5. The higher the level is, the deeper the color tone of an image results.

→ “5.3.3 Setting FICE”

3.11 Patient Info. + Scope Info. Dialog

When registering the new patient information or switching the patient information, the Patient Info. + Scope Info. dialog is displayed.

Patient information	ID	123456		
	Name	FUJI TAROU		
	Message	None		
	Sex	None	Doctor	None
	D. o. B.	----/--/--	Procedure	None
	Age	--	Number of recordable images in Internal Memory : 20856	
	Scope information	Scope Type	EC-740T/M	Forceps
Scope Serial		AC732G004	Distal	9.8
Scope ID		2	Flexible	10.7

In the patient information area, the information registered in the Patient Information Entry screen is displayed.

➔ “5.2 Registering and Editing Patient Information”

In the scope information area, the minimum diameter of instrument channel, outer diameter of distal end or outer diameter of insertion tube may not be displayed depending on the date of manufacture when the 600 system scope or 500 system scope is connected.

The water jet nozzle position is displayed only when some models of the 700 system scope are connected.

4.1 System Installation

WARNING

- If any peripherals not described in “2.2 Equipment Using in Combination” are used, this product may not function properly, and electric shock, equipment damage, or injury to patients or physicians may occur.
- If the power cords of the peripherals are connected without using the insulation transformer on the cart, the enclosure leakage current may increase, posing a risk of injury or electric shock to the patient and/or the physician when he/she comes into contact with those devices.
- When using a network, insert an EN 60601-1 compliant separator between the LAN cable, which connects the devices, and the network system. If such a separator is not used, the enclosure leakage current may increase due to the current being leaked from the connected network system or due to the electric potential difference between grounds. This may pose a risk of injury or electric shock to the patient and/or the physician when he/she comes into contact with the devices.
- This product conforms to the EMC standard (EN 60601-1-2: 2015). However, the radio waves radiated from this product may cause medical devices such as a pacemaker to malfunction. When this product is used for a patient with an active implantable medical device, consult a cardiovascular specialist and the manufacturer of the active implantable medical device.
- Use the rated voltage only. Not doing so may cause a fire or electric shock.
- Connect the power plug directly to the protective earth receptacle. Use peripherals that are compliant with the medical safety standards. Not doing so may cause an electric shock.
- Do not use the equipment in atmosphere of flammable gas or oxygen-rich environment. Doing so may cause explosion or fire.
- Do not simultaneously touch the patient and any of the system devices in the patient environment. Doing so may cause electric shock.
- If the power cords of the peripherals are connected without using the insulation transformer on the cart, the enclosure leakage current may increase, posing a risk of injury or electric shock to the patient and/or the physician when he/she comes into contact with those devices.

CAUTION

- Configure the ME system in accordance with the maximum allowable current of the power strip to be used.
- If a peripheral is used, connect it to a receptacle via an insulating transformer. Connect peripherals in accordance with the specification of the insulating transformer.
- Use the multi-tap installed in the cart only for the equipment used for this system. If it is used for other equipment, the current capacity may increase and the equipment may not operate properly.
- Use the rated voltage only. Not doing so may cause a fire, electric shock or malfunction.
- Install equipment in a location in which the power cord or connected endoscope will not become entangled. Equipment may fall over or down, the screen may go black, or the patient or operator may be injured.
- To use this product with peripheral devices, properly connect the input and output terminals as per the products' instructions. Incorrect connections may cause equipment failure.
- Do not block ventilation holes located on the left side and rear panel of this product.

Note

- Adjust the position of the movable shelf of the cart depending on your system.
- Install the equipment on a level location free from vibration and shock. The equipment may tip over and be damaged.
- Secure the LCD monitor to the cart. The LCD monitor may fall off.
- For the DVI cable connecting the LCD monitor to the processor, use either the cable that comes with the monitor or one of 5m or less based on the DVI standards. Otherwise, images may not be displayed properly.
- Do not block ventilation holes. Doing so may cause overheat on equipment.
- Connect the power plugs of the processor directly into the receptacles for the processor and light source on the cart.
- When a peripheral for system expansion is installed, restart the processor.
- Do not bump or strongly shock the power connector of the endoscope. Install the processor so that the scope connector or LG connector of the endoscope connected to the light source is not bumped or strongly shocked by surrounding objects. When operating an electric bed or similar device, avoid hitting it against the scope connector or LG connector of the endoscope connected to the light source. There is a risk of damaging the endoscope or processor.

4.1.1 Installation Flowchart

The installation flowchart of this product is shown below. Refer to each section by following this flowchart.

- 1** Installing this product onto the cart
↓ → “4.1.2 Installation onto the Cart (Standard System Installation Example)”
- 2** Connecting the WC-LINK cable
↓ → “4.1.3 Connecting the WC-LINK cable”
- 3** Attaching the dustproof filter to this product
↓ → “4.1.4 Attaching the Dustproof Filter (Louver)”
- 4** Connecting this product and the LCD monitor
↓ → “4.1.5 Connecting the Monitor”
- 5** Connecting this product and the keyboard
↓ → “4.1.6 Connecting the Keyboard”
- 6** Connecting peripherals when necessary
↓ → “4.1.7 Installation for System Expansion”
→ “4.1.8 Printer Connection (Remote System)”
→ “4.1.9 Printer Connection (RS-232C System)”
→ “4.1.10 Digital Printer Connection”
→ “4.1.11 Video Recorder Connection (Remote System)”
→ “4.1.16 Connecting Equipment (EX-WS) with EW1 System Software”
- 7** Connecting the equipment to the power supply
→ “4.1.12 Connecting the Power Source”

4.1.2 Installation onto the Cart (Standard System Installation Example)

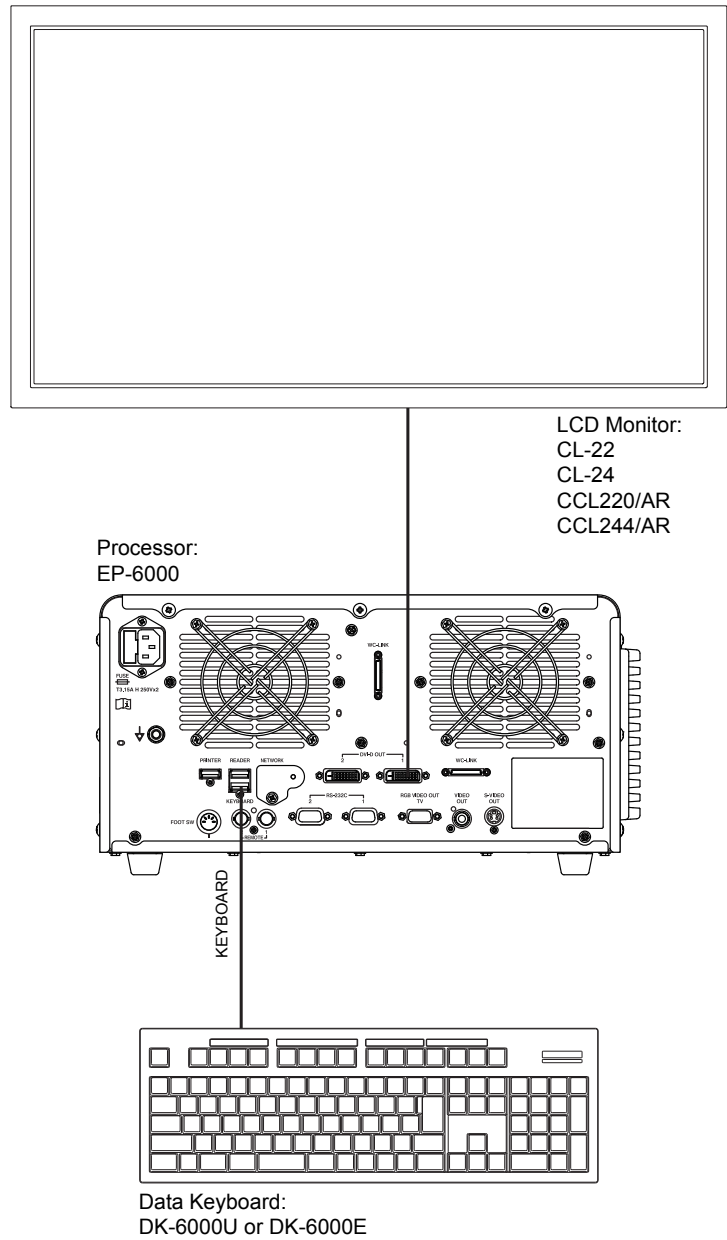

(1) Lock the casters of the cart.

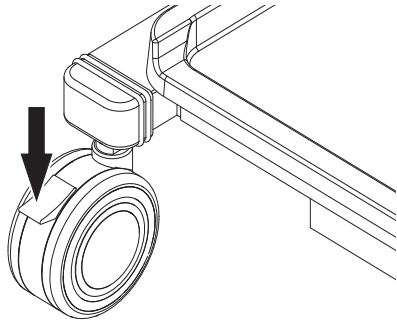

- (2) Remove two screws on the rear panel of the cart to take off the rear cover.

Note

- When all the installation work is completed, reinstall the rear cover of the cart.

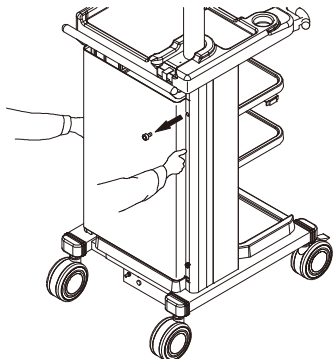

- (3) Place your hand on the bottom surface of this product and lift one side up.

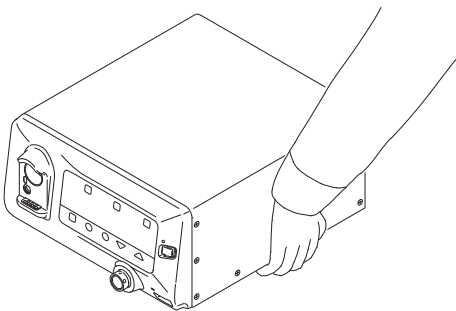

- (4) While lifting the bottom up, place the other hand under the bottom of the front panel.

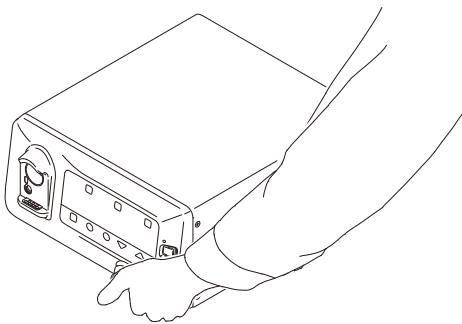

- (5) In the same manner, the other person lifts up the other side of the unit.

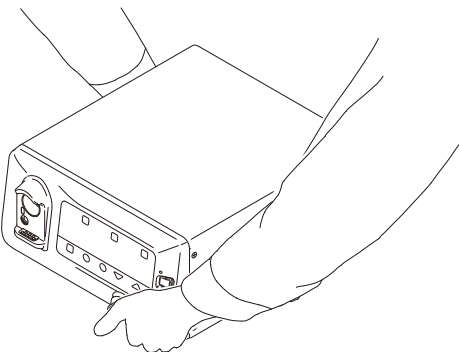

- (6) Hold the unit steadily using two persons.

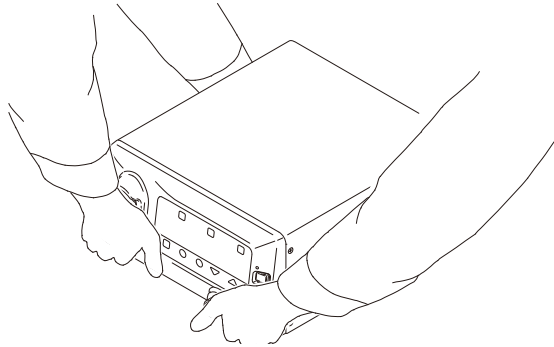

- (7) Place this product onto the shelf of the cart.

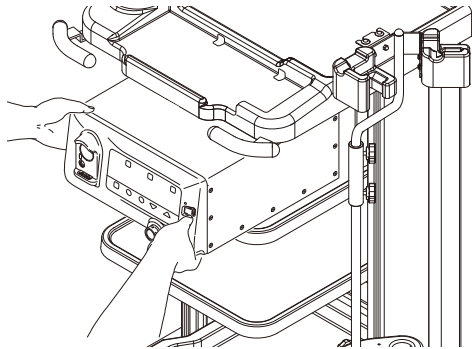

Note

- To prevent falls, make sure that the feet of this product are placed inside the stoppers of the shelf.

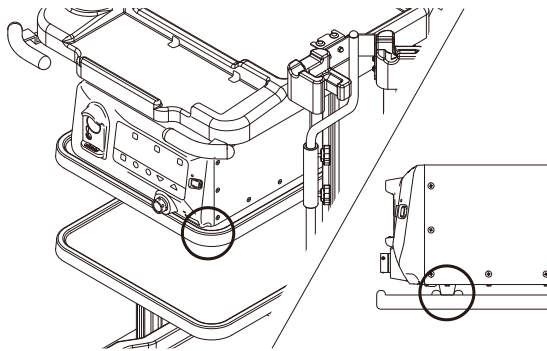

- (8) When installing, leave a gap of 100 mm or more between the side and rear surfaces of this product and the wall and 700 mm between the front surface and the wall.

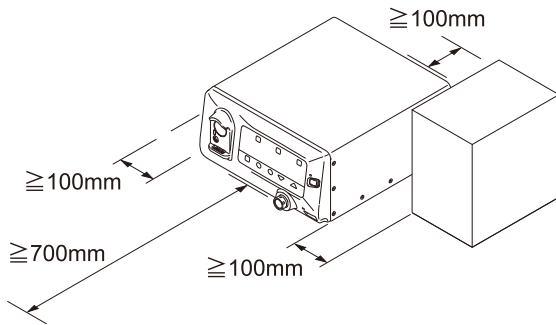

Note

- Use this product in combination with the devices necessary for endoscopic examinations.
 - After all devices are connected, connect the power cord.
- “4.1.12 Connecting the Power Source”

4.1.3 Connecting the WC-LINK cable

Connect the WC-LINK cable to the WC-LINK terminal.

Processor:
EP-6000

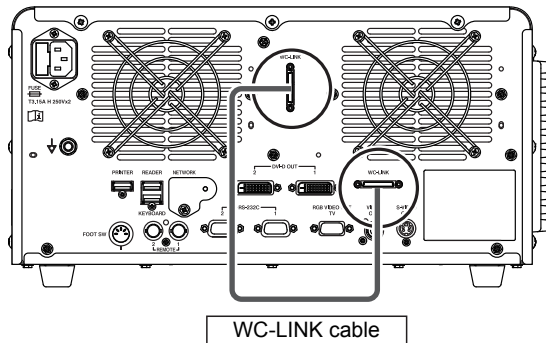

Note

- After all devices are connected, connect the power cord.
- “4.1.12 Connecting the Power Source”

4.1.4 Attaching the Dustproof Filter (Louver)

- (1) Attach the dustproof filter to the louver. Align the center protrusion of the dustproof filter with the louver.

Align the dustproof filter with the protrusion of the louver, and then push the center protrusion of the dustproof filter into the louver to attach it.

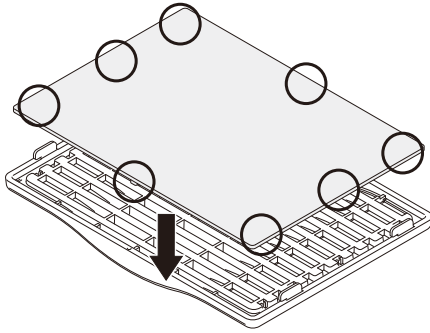

- (2) Attach the louver to this product.

Make sure that the louver is fully inserted into this product. Not doing so may cause equipment damage.

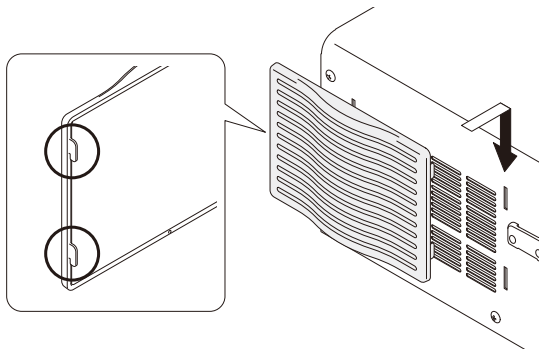

4.1.6 Connecting the Keyboard

Connect the cable of the data keyboard to the keyboard terminal of this product.

Note

- The type of the data keyboard varies depending on the country.
- For details on how to install the keyboard onto the keyboard tray of the cart, refer to the operation manual of the cart.

Processor:
EP-6000

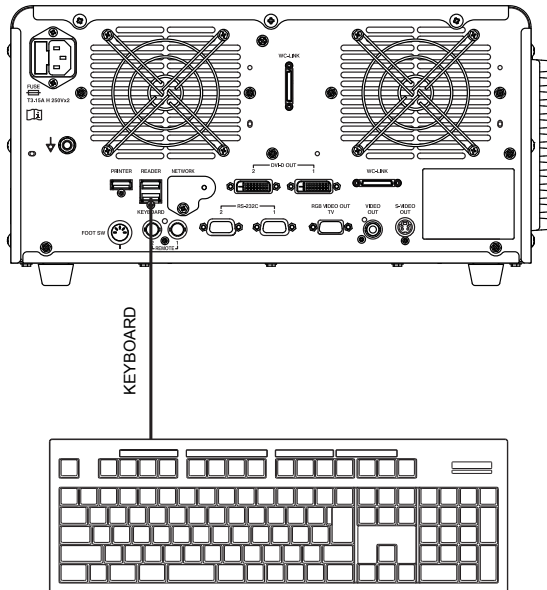

Data Keyboard:
DK-6000U or DK-6000E

Note

- After all devices are connected, connect the power cord.
- “4.1.12 Connecting the Power Source”

4.1.7 Installation for System Expansion

This system can be expanded by adding other peripherals to the standard system.

The image below is an example of the expanded system in which a printer and video recorder are mounted.

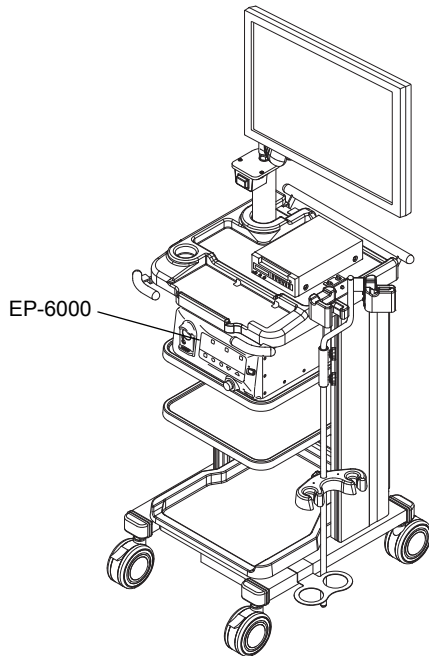

Example of Installation

WARNING

When mounting peripherals on the cart, observe the following precautions.

<To avoid electric shock>

- Connect the power plugs of this product directly to the receptacles for the processor/light source on the cart.
- Never connect the power source of an electrosurgical unit to the cart.
- Never connect the power source of this product to a power cord that has been placed on the floor.
- Never connect the power source of a second cart to the first cart.
- Additional power strips or extension cords must not be connected to the medical system.
- Do not connect any unit other than the equipment composing this system to the power strip.

<To avoid toppling over of equipment>

- Do not stack the peripherals.
- Make sure that the feet of each unit are placed inside of the stoppers.
- Make sure that the feet of each unit are placed inside of the stoppers on the movable shelf of the cart.

<To avoid malfunction due to lightning>

- Connect the equipment to a power source suitable for the structure and facilities of the hospital or clinic.

CAUTION

- To use this product with peripheral devices, properly connect the input and output terminals as per the products' instructions. Incorrect connections may cause equipment failure.
- Do not block ventilation holes located on the left side and rear panel of this product.

For the installation of the expanded system, follow the contents in the operation and installation manuals of each unit.

<Example of Expanded System Connections>

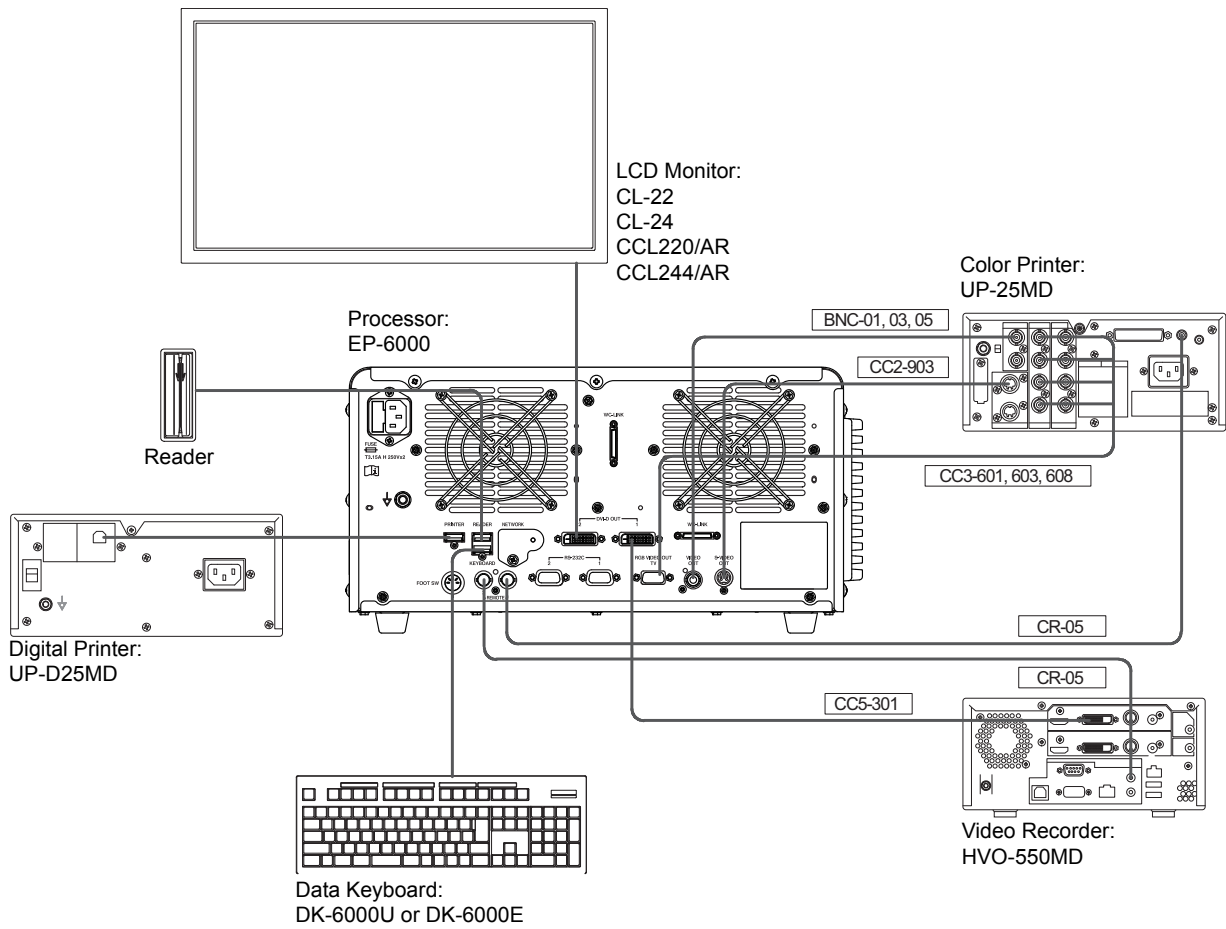

4.1.8 Printer Connection (Remote System)

Note

- When the image output from the processor is displayed on the monitor via the printer, the image may flicker or disappear. Connect the monitor used as the main observation screen directly to the processor.

<Connection 1> When the image is captured by using the switch of Endoscope

Color Printer:
UP-25MD

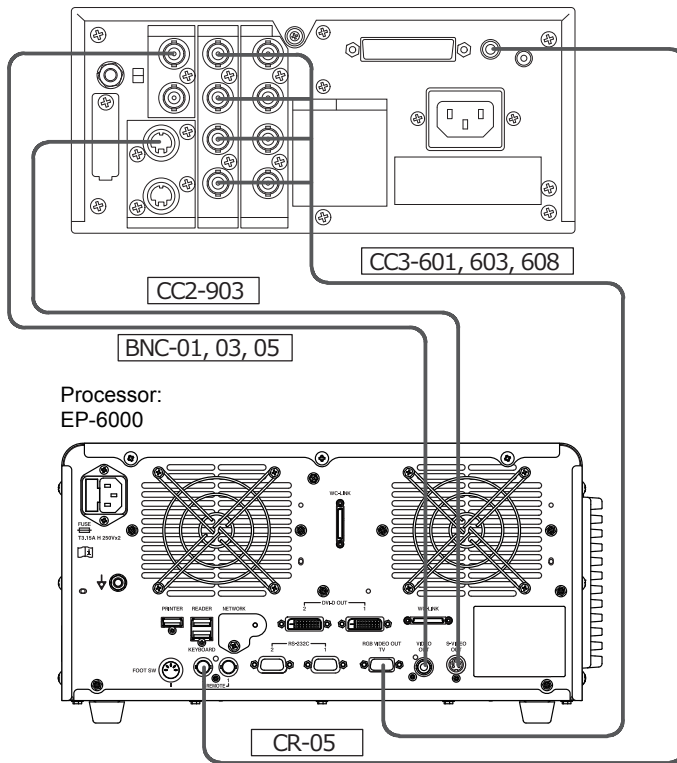

<Connection 2> When the image is captured by the foot switch

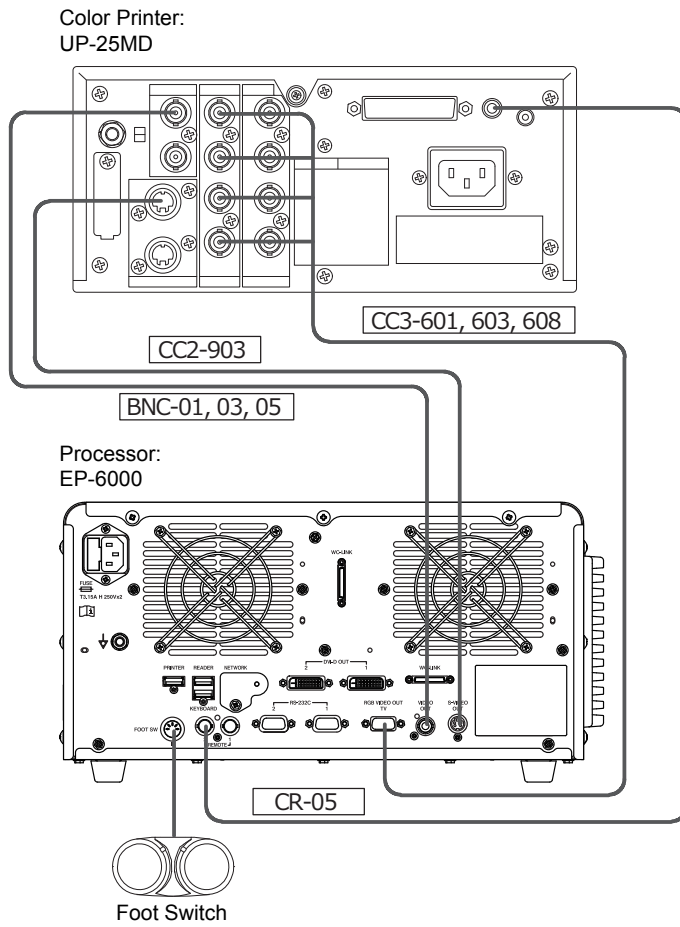

Note

- Use this product in combination with the devices necessary for endoscopic examinations.
- After all devices are connected, connect the power cord.
- ➔ “4.1.12 Connecting the Power Source”

4.1.9 Printer Connection (RS-232C System)

Note

- Check the peripheral device selected in the Peripheral Setup screen to confirm the baud rate of the processor. The baud rate of the processor is automatically selected depending on the selected peripheral device.
When a peripheral device connected with the RS-232C interface is controlled from the processor, match the communication speed of the peripheral device with the baud rate of the processor. If the baud rate does not match, the peripheral device does not function normally.
For details on how to set the baud rate, refer to the instruction manual for each peripheral device.
- When the image output from the processor is displayed on the monitor via the printer, the image may flicker or disappear momentarily. Connect the monitor used as the main observation screen directly to the processor.

<Connection Example>

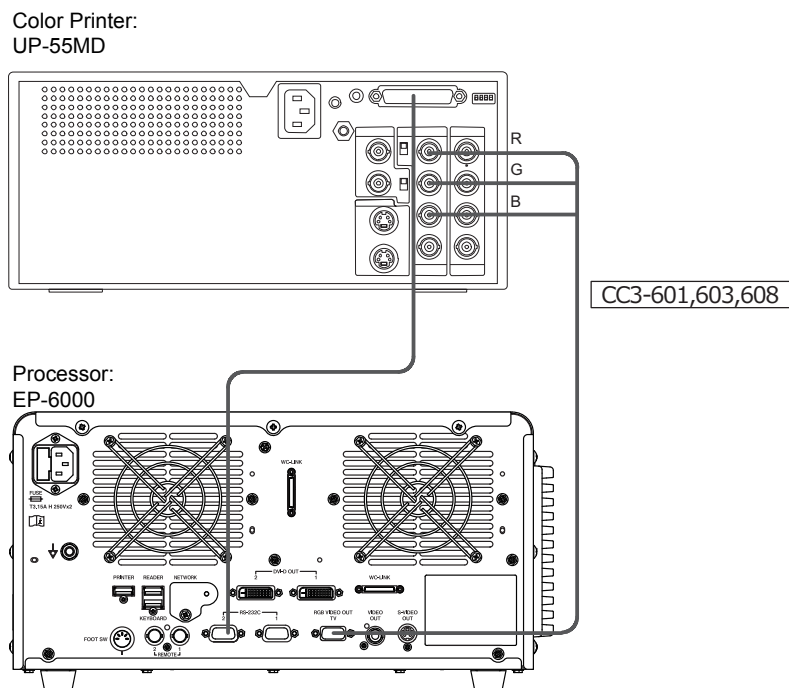

Note

- Use this product in combination with the devices necessary for endoscopic examinations.
 - After all devices are connected, connect the power cord.
- ➔ “4.1.12 Connecting the Power Source”

4.1.10 Digital Printer Connection

Digital Printer:
UP-D25MD

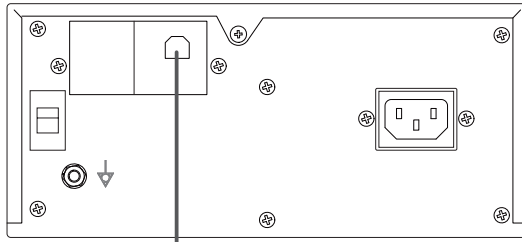

Processor:
EP-6000

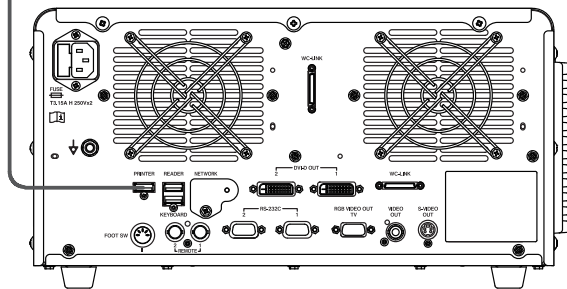

Note

- Use this product in combination with the devices necessary for endoscopic examinations.
 - After all devices are connected, connect the power cord.
- ➔ “4.1.12 Connecting the Power Source”

4.1.11 Video Recorder Connection (Remote System)

<Connection Example>

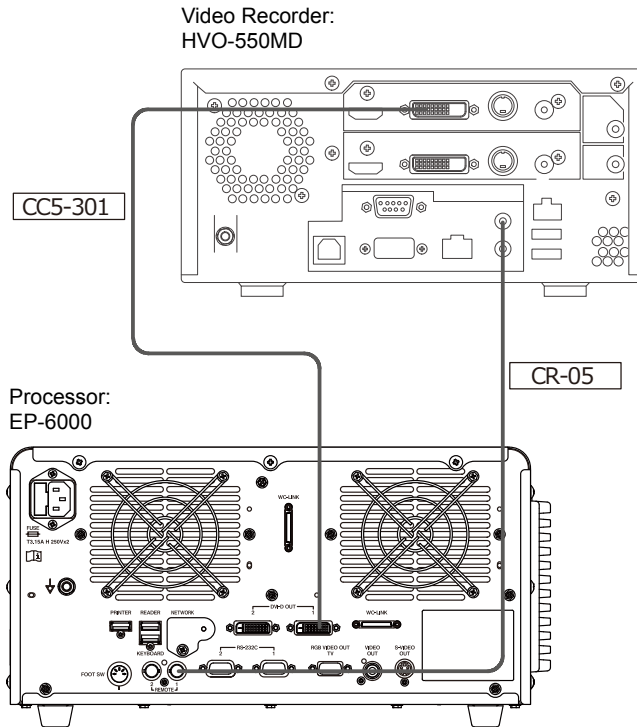

Note

- Use this product in combination with the devices necessary for endoscopic examinations.
 - After all devices are connected, connect the power cord.
- ➔ “4.1.12 Connecting the Power Source”

4.1.12 Connecting the Power Source

- (1) Connect the prescribed power cord by pushing it securely into the power source connection section of this product.

Note

- Use only the power cord prescribed for the processor.
➔ “4.1.15 Basic Information on Power Cord”
- Even when the power cord is already connected, make sure that the power cord is connected securely.

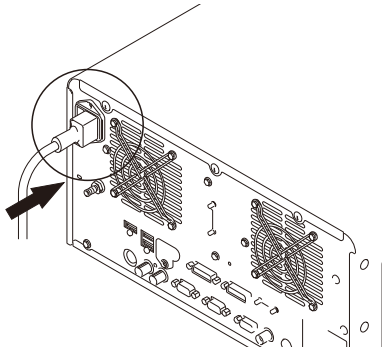

- (2) Connect the power plugs of this product directly to the receptacles for the processor and light source on the cart.

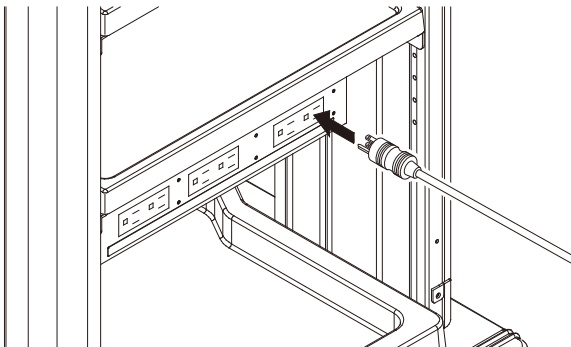

- (3) Connect the power cord provided with the LCD monitor to the power supply connector on the LCD monitor.

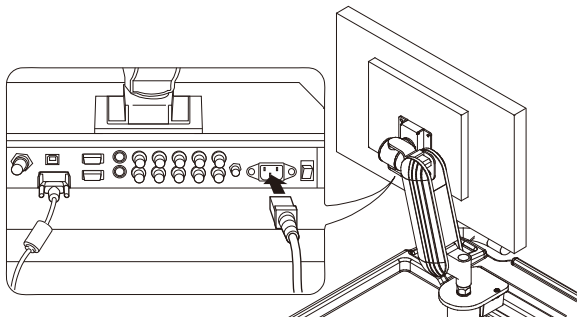

- (4) Connect the power plug of the LCD monitor to the receptacle for peripherals on the cart.

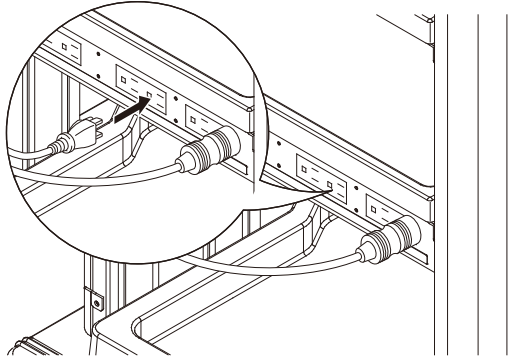

- (5) Plug the power cord of the cart into a protective earth receptacle.

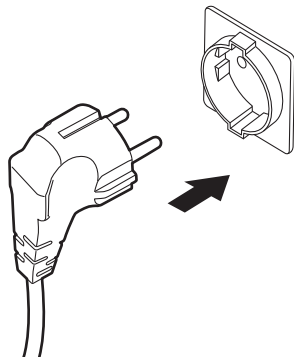

4.1.13 Power Source

Installation of this system must be performed according to EN 60601-1. When installing this system, follow the descriptions below.

<Power connection for using equipment in combination>

The equipment which can be used in combination with this system is divided into the following three types according to its power connection.

- (1) Equipment which is directly combined with this system (Applicable to EN 60601-1)
The equipment that makes up this product and system.
Examples of such equipment are shown in Table 4.1.
- (2) Equipment which can be used when its power is supplied from a power source other than the cart in which this system is installed. (Applicable to EN 60601-1)
Examples of such equipment are shown in Table 4.2.
- (3) Peripherals which are used when required power is supplied from an insulated transformer applicable to EN 60601-1 (Applicable or conforming to EN 60601-1 or EN 60950)
Examples of such equipment are shown in Table 4.3.

The equipment other than these three types may not be safe. Do not use such equipment.

In combination with any of the equipment above, all configurations shall comply with the requirement for ME systems of EN 60601-1.

In any combination of the equipment above, all configurations must comply with the requirements of ME systems of EN 60601-1.

Note

- These combinations are determined based on electrical safety. The performance of the equipment depends on the specifications of each manufacturer.

Table 4.1 Equipment configuring the system

Type	Model name
Processor	EP-6000
Data Keyboard	DK-6000U or DK-6000E *
Endoscope	700 system scopes, 600 system scopes, 500 system scopes

* The type of the data keyboard varies depending on the country.

Table 4.2 Medical equipment used when its power is supplied from other power source

Type	Model name
Electrosurgical Unit *	-

* For electrosurgical units that can be combined, see the instruction manual of the endoscope.

Table 4.3 Peripherals used when its power is supplied from an insulated transformer

Type	Model name
Ultrasonic Processor	SU-1, SP-900
LCD Monitor	CL-22 (FUJIFILM), CL-24 (FUJIFILM), CCL220/AR (JVC KENWOOD), CCL244/AR (JVC KENWOOD)
Printer	UP-25MD (SONY), UP-55MD (SONY), UP-D25MD (SONY)
Video Recorder	HVO-3300MT (SONY), HVO-1000MD (SONY), HVO-550MD (SONY)

4.1.14 Connecting the Power Source When Using the Cart

The cart is equipped with two types of receptacles; one is “receptacles for processor/light source” used for connecting the processor, light source and the other is “receptacles for peripherals” used for connecting peripherals.

Before connecting them, turn the main switch of the cart off or unplug the power cord.

Connect the power plug of the cart into a protective earth receptacle. For the electrosurgical unit, use the power source other than the one for the cart.

Do not connect equipment not listed in “2.2 Equipment Using in Combination”.

Make sure that the total of the rated currents of the devices connected to the receptacles for processor/light source and receptacles for peripherals do not exceed the rated currents of the receptacles.

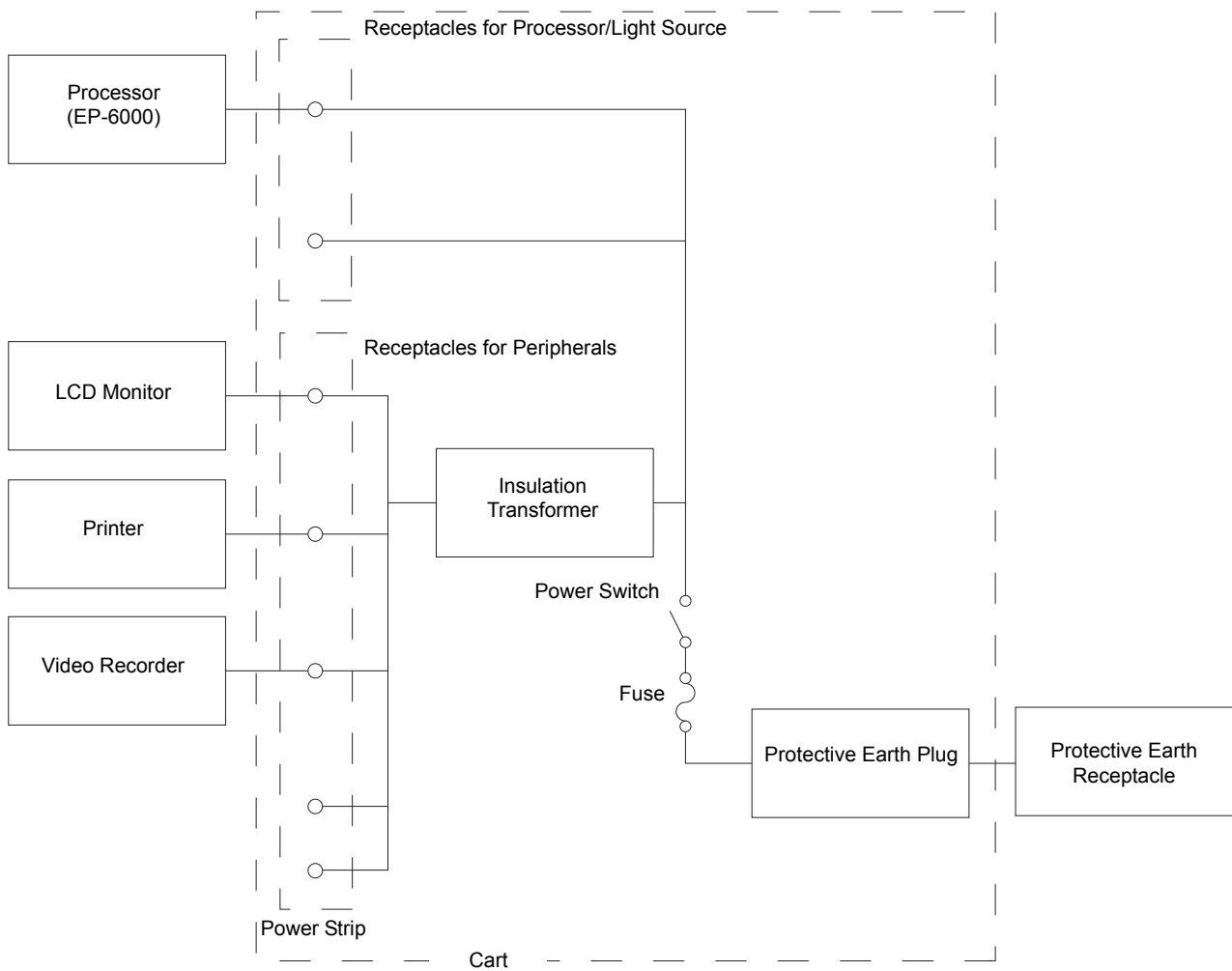

4.1.15 Basic Information on Power Cord

Device connector	IEC 60320-1 C13
Cross-section area of cable	1.0 mm ² or more, 3 wires (200V input) 16AWG or more, 3 wires (USA)
Input voltage	100V to 120V: 125VAC or more More than 120V to 240V: 250VAC or more
Rated current	USA: 13A or more Other areas: 6A or more
Cable length	3 m or less
Power plug	3-pin plug that complies with the laws and regulations of each country

4.1.16 Connecting Equipment (EX-WS) with EW1 System Software

CAUTION

- Be sure to connect the monitor to each of the EX-WS and this product.

LCD Monitor:
 CL-22
 CL-24
 CCL220/AR
 CCL244/AR

LCD Monitor:

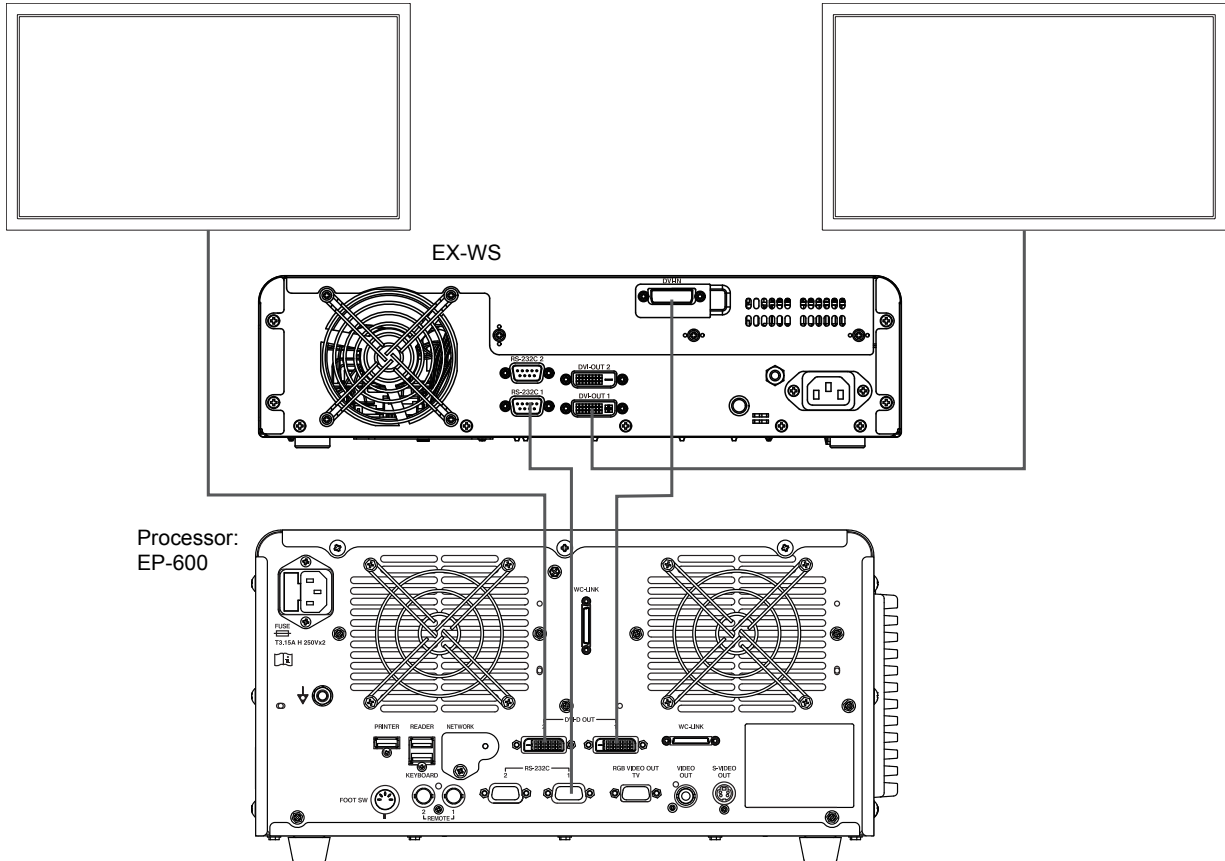

Note

- For details on the connection of the EX-WS, refer to the operation manual of the EW1 System Software.
- Use this product in combination with the devices necessary for endoscopic examinations.
- After all devices are connected, connect the power cord.
- ➔ “4.1.12 Connecting the Power Source”

4.2 Initial Settings at the Time of Installation

This section explains the initial settings of the system.

Note

- During the observation, the observation screen is displayed in the sub-screen at the lower right side of the setup screen.

4.2.1 Flowchart of System Settings at the Time of Installation

The flowchart of system settings at the time of installation is described below. Refer to each section by following this flowchart.

Note

- Perform the settings by following the basic operation procedure of system settings.
→ “4.2.2 Basic System Setup Operations”
- The date and time were set in default at the shipment from the factory. Change them if necessary.
- For the items in the System Setup menu other than those described in this flowchart, perform the settings if necessary.

1 Set the items on the “Function” tab.

- Selecting the mask type of the observation screen
- Assigning a function to the Multi button



- Assigning a function to the Multi key
→ “4.2.3 Function Tab”

2 Set the items on the “Display” tab.

- Selecting the exam data to be displayed on the observation screen



- Assigning a function to the Space key
→ “4.2.4 Display Tab”

3 Set the items on the “Basic setting” tab.

- Date and time
- Screen resolution



- Speaker volume
→ “4.2.5 Basic Setting Tab”

4 Set the items on the “Endoscope” tab.

- Assigning a function to the scope switch



- “4.2.7 Endoscope Tab”

5 Set other functions if necessary.

- Assigning a function to the foot switch *
→ “4.2.8 Setting Foot Switch (FS1)”
- Switching the shutter speed *
→ “4.2.9 Setup for Switching the Shutter Speed During Optical Zoom”
- Registering doctor names in the doctor list
→ “4.2.10 Setting the Doctor's Name”
- Registering procedure names in the procedure list
→ “4.2.11 Setting the Procedure Name”
- Registering messages in the message list
→ “4.2.12 Setting the Message”

* This setting is performed only by service personnel.

4.2.2 Basic System Setup Operations

- (1) Press the [System] key on the keyboard. The System Setup screen appears.

Note

- Essentially the same operation applies to other setup keys.
- During the observation, the observation screen is displayed in the sub-screen at the lower right side of the setup screen.

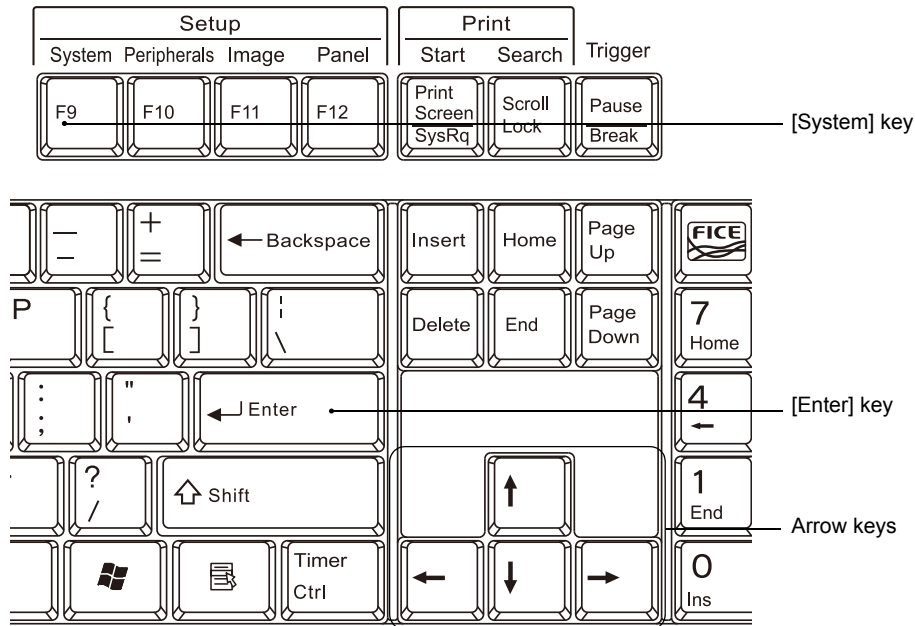

- (2) On the setup screen, use the [↑] and [↓] keys to select an item.

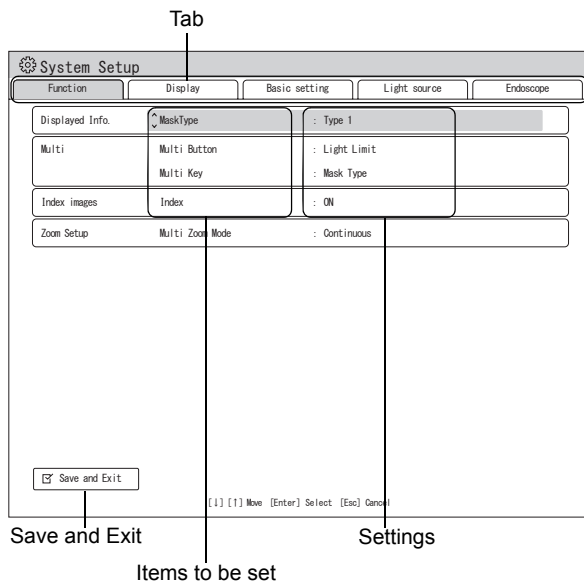

- (3) Use the [←] and [→] keys to select a category.

Note

- When a list has multiple pages, use the [←] and [→] keys to toggle between pages.

- (4) To change the value of an item, select the item and press the [Enter] key. This enables you to select a different value or directly enter the desired value.

Note

- Use the [↑] and [↓] keys to select a value.
- For the items with a “↵” mark at the right end, a submenu is displayed.
- When “[Insert] Edit” is displayed at the bottom of the menu screen, if the [Insert] key is pressed, the desired value can be entered directly by using the keyboard.

- (5) After a value is changed, press the [Enter] key to move the cursor to the next item.

Note

- When a value is entered directly by using the keyboard, the cursor may automatically move to the next item after the input is completed.

- (6) To save the settings, move the cursor to “Save and Exit” and press the [Enter] key.

Note

- Be sure to select “Save and Exit” when a setting is changed. Otherwise, the changed value is not saved.

4.2.3 Function Tab

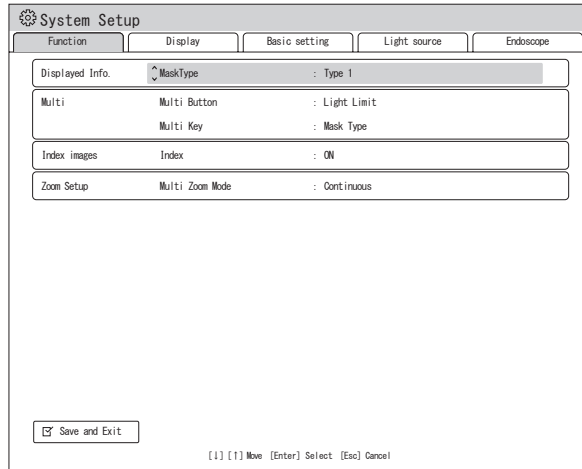

Category	Item	Value	Description
Displayed Info.	Mask Type	Type 1	Set the mask type on the observation screen.
		Type 2	
Remarks <ul style="list-style-type: none"> When the observation mode is BLI, BLI-bright or LCI, no image is displayed in the sub-screen even if "Type 2" is selected. <p>➔ "3.9 Data Display on the Observation Screen"</p>			
Multi	Multi Button	Light Limit	Configure the function to be assigned to the MULTI button located on the front panel of this product. After configuration, press the MULTI button to ensure that the selected function works.
		Structure Emphasis	
		Color Emphasis	
		Shutter Speed	
		FICE	
		Reset	
		Timer	
		Lap Time	
		Mask Type	
		Multi Zoom Mode	
		CAD Mode	
	Movie Recording (EX-WS)		
	Multi key	Reset	Configure the function to be assigned to the [Multi] key on the keyboard. After configuration, press the [Multi] key to ensure that the selected function works.
		Lap Time	
Mask Type			
Multi zoom mode			
CAD Mode			
	Movie Recording (EX-WS)		

Category	Item	Value	Description
<p>Remarks</p> <ul style="list-style-type: none"> • Light Limit <ul style="list-style-type: none"> ➔ “7.9 Light Save Function” • Structure Emphasis <ul style="list-style-type: none"> ➔ “5.3.2 Structure Emphasis Settings” ➔ “7.11 Turning On/Off Structure Emphasis” • Color Emphasis <ul style="list-style-type: none"> ➔ “5.3.4 Tone Settings” ➔ “7.13 Turning On/Off the Tone” • Shutter Speed <ul style="list-style-type: none"> ➔ “5.3.6 Setting the Shutter Speed” ➔ “7.14 Switching the Shutter Speed” • FICE <ul style="list-style-type: none"> ➔ “5.3.3 Setting FICE” ➔ “7.12 Turning On/Off FICE” • Reset <p>Reset the counter indicating the number of captured images to 0. In addition, when the observation screen is displayed, if this button is held pressed for 2 seconds, the color adjustment vales are reset to the factory defaults.</p> • Timer <ul style="list-style-type: none"> ➔ “7.17.2 Starting/Stopping the Timer” • Lap Time <ul style="list-style-type: none"> ➔ “5.5.5 Lap Time Display” • Mask Type <p>The mask type is changed as follows each time the button is pressed. Type 1 → Type 2 → Back to Type 1</p> <ul style="list-style-type: none"> ➔ “3.9 Data Display on the Observation Screen” • Multi Zoom Mode <p>The multi zoom mode is changed as follows each time the button is pressed. Continuous → 2 Step → 3 Step → 5 Step → Continuous</p> <ul style="list-style-type: none"> ➔ “5.5.4 Setting Multi Zoom Mode” • CAD Mode <p>Computer-aided diagnosis mode of the EW1 System Software is switched. For details on the available endoscopes and operating method, refer to the operation manual of the EW1 System Software.</p> • Movie Recording (EX-WS) <p>The movie recording function of the EW1 System Software is switched to ON/OFF. For details on the available endoscopes and operating method, refer to the operation manual of the EW1 System Software.</p> 			

Category	Item	Value	Description
Index images	Index	ON	When set to ON, the newest four index images stored in the internal storage device are displayed.
		OFF	
Remarks <ul style="list-style-type: none"> Index images can be displayed only when the screen resolution is set to Full HD. → “5.5.2 Index Image Display”			
Zoom Setup	Multi Zoom Mode	Continuous	Set the type of zoom operation that is applied when an endoscope with the optical zoom function is used in combination with this product.
		5 Step	
		3 Step	
		2 Step	
Remarks <ul style="list-style-type: none"> This item needs to be set by service personnel. Endoscopes that do not support the multi zoom operating mode operate in the continuous mode, regardless of this setting. → “5.5.4 Setting Multi Zoom Mode”			

Note

- For the operations on the menu screen, refer to the description of basic system setup operations.
- “4.2.2 Basic System Setup Operations”

4.2.4 Display Tab

CAUTION

- When the setup screen for the equipment (EX-WS) with EW1 System Software is displayed, “Displaying EX-WS Menu” is displayed on the monitor connected to this product.

System Setup

Function | Display | Basic setting | Light source | Endoscope

Displayed Info. Exam Data : Patient ID
Exam Info. : ON

Space Key Screen display switching : Patient info. OFF

Lap Time Setup Lap Time : OFF

Hospital Name Hospital Name :

Scope Info. Priority Scope Information : Distal End

EX-WS Setup

Save and Exit

[1] [1] Move [Enter] Select [Esc] Cancel

Category	Item	Value	Description
Displayed Info.	Exam Data	Patient ID	Select exam data to be displayed on the observation screen.
		Exam No.	
	Exam Info.	ON	The Patient Info. + Scope Info. dialog is displayed at the beginning of an examination. → “3.11 Patient Info. + Scope Info. Dialog”
		OFF	
Remarks <ul style="list-style-type: none"> The Patient Info. + Scope Info. dialog may be displayed at times other than the beginning of an examination. When this item is set to OFF, the Patient Info. + Scope Info. dialog is not displayed at all times. 			
Space Key	Screen display switching	Patient info. OFF	Select the type of data that is displayed or hidden on the observation screen each time the [Space] key is pressed.
		Observation mode only	
		All OFF	
Remarks <ul style="list-style-type: none"> When “Patient info. OFF” is selected, the patient information, date and time are hidden. When “Observation mode only” is selected, the focus meter, electronic zoom ratio, special light observation mode and spectral image processing function are displayed. Even if “All OFF” is selected, the lap time is displayed. 			

Category	Item	Value	Description
Lap Time Setup	Lap Time	ON	The lap time can be displayed on the observation screen.
		OFF	
Remarks <ul style="list-style-type: none"> The lap time can be displayed only when the screen resolution setting is Full HD. Lap Time <ul style="list-style-type: none"> → “5.5.5 Lap Time Display” 			
Hospital Name	Hospital Name	To be entered by using the keyboard	Enter the hospital name.
Scope Info.	Priority Scope Information	Scope Switch	When the output resolution is set to “SXGA” and the mask type is set to “Type 1”, scope information to be displayed preferentially (information on scope switches or information on the scope distal end) can be selected.
		Distal End	
Remarks <ul style="list-style-type: none"> When “Distal End” is selected, information on scope switches 4 and 5 is not displayed. → “3.9 Data Display on the Observation Screen” 			
EX-WS	Setup		The setup screen for the EX-WS is displayed on the monitor connected to the equipment (EX-WS) with EW1 System Software. To exit the setup screen, press the [Esc] key.

Note

- For the operations on the menu screen, refer to the description of basic system setup operations.
 - “4.2.2 Basic System Setup Operations”
- For details on operations on the setup screen for the EX-WS, refer to the operation manual of the EW1 System Software.

4.2.5 Basic Setting Tab

CAUTION

- If “Full HD” is selected for “Screen Resolution” when a non-Full HD monitor is used, the image is not displayed properly on the monitor. If this happens, press the [Ctrl], [Alt] and [S] keys at the same time. The screen resolution setting changes to “SXGA” and a buzzer sounds. When a buzzer sound is heard, restart the processor. If a buzzer sound is not heard, check whether or not the correct keys are pressed and then try again.

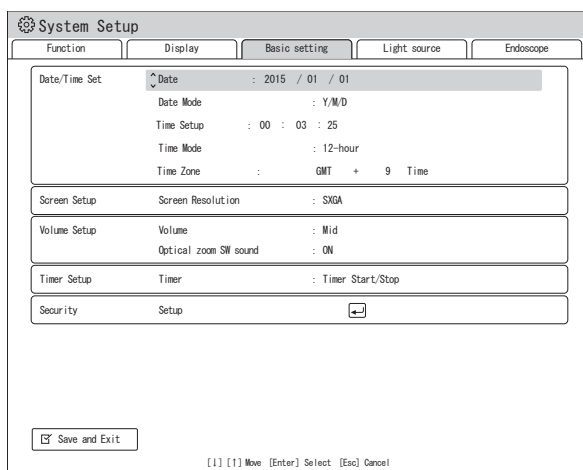

Category	Item	Value	Description
Date/Time Set	Date ^{*1}	To be entered by using the keyboard	Enter the year, month and day. Enter the Christian year.
	Date Mode	Y/M/D	Year/Month/Day
		D/M/Y	Day/Month/Year
		M.D.Y	Month.abbr.Day.Year
	Time Setup ^{*1}	To be entered by using the keyboard	Enter the time. When the [Enter] key is pressed, the time set for the equipment starts elapsing.
	Time Mode	24-hour	Set the hour-display format.
		12-hour	
Time Zone ^{*2}	+9 hours	The time difference between the local time and Greenwich Mean Time.	
	-9 hours		
Remarks ^{*1} The date and time were set in default at the shipment from the factory. Change them if necessary. ^{*2} The time difference between the local time and Greenwich Mean Time is set. Change the time zone in accordance with the local time.			

Category	Item	Value	Description
Screen Setup	Screen Resolution	SXGA	Set the screen resolution of the monitor.
		Full HD	
Remarks <ul style="list-style-type: none"> • After configuration, restart this product. • Do not change this setting during or immediately before an examination. Change this setting when there is sufficient time before the next examination. • When a Full HD wide monitor compatible with this product is used, the screen can be displayed in Full HD. For details on the monitor in use and how to change the setting, consult your local FUJIFILM dealer. • If “Full HD” is selected for “Screen Resolution” when a non-Full HD monitor is used, the image is not displayed properly on the monitor. If this happens, press the [Ctrl], [Alt] and [S] keys at the same time. The screen resolution setting changes to “SXGA” and a buzzer sounds. When a buzzer sound is heard, restart the product. If a buzzer sound is not heard, check whether the correct keys were pressed, and then try again. 			
Volume Setup	Volume	Hi	Set the volume of the speaker.
		Mid	
		Low	
		OFF	
	Optical zoom SW sound	ON	When the optical zoom function is assigned to a scope switch, if the scope switch is pressed, a beep sound is generated.
		OFF	
Remarks <ul style="list-style-type: none"> • A confirmation sound beeps when the speaker volume is set. When OFF is selected, the speaker is mute. 			
Timer Setup	Timer	Timer Start/Stop	Start/stop the timer by pressing the [Timer] key.
		Auto start at Exam.	The timer starts simultaneously with starting the examination.
Remarks <ul style="list-style-type: none"> • Timer → “7.17.2 Starting/Stopping the Timer” 			
Security	Setup		Perform security settings. → “4.3 Security Function”

Note

- For the operations on the menu screen, refer to the description of basic system setup operations.
→ “4.2.2 Basic System Setup Operations”

4.2.6 Light Source Tab

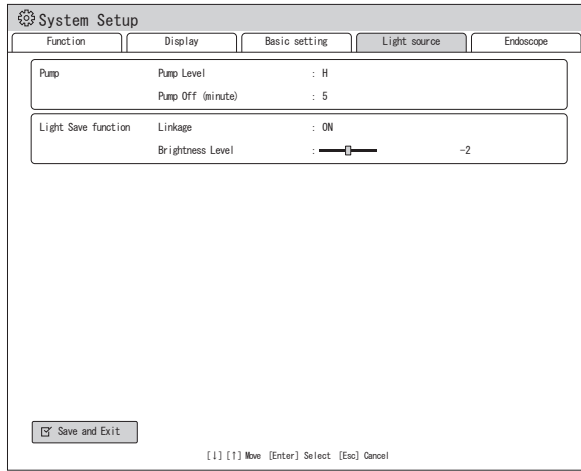

Category	Item	Value	Description
Pump	Pump Level	H	Set the pump setting at the beginning of an examination.
		M	
L			
OFF			
	Pump Off (minute)	0 to 60 (minutes)	When the period of time specified here has elapsed after an examination is finished, the air supply pump is automatically turned off.
Light Save function	Linkage	ON	When set to ON, if the Light Limit function is turned on by pressing the Multi button on the front panel, the shutter speed is fixed to 1/60 and the value set in "Brightness Level" below is applied.
		OFF	
	Brightness Level	-4 to 0	When "Linkage" above is set to ON, if the Light Limit function is turned on, the brightness level set here is applied as the standard value of the brightness. This function is the same as the brightness level adjustment function.

4.2.7 Endoscope Tab

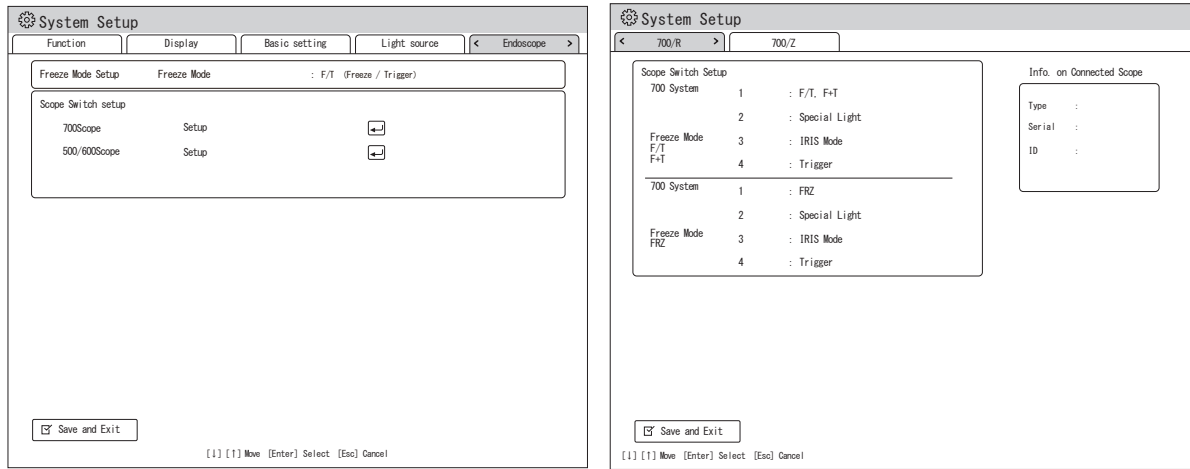

Table 1

Category	Item	Value	Description
Freeze Mode Setup	Freeze Mode	F/T (Freeze/Trigger)	Set the freeze mode to be assigned to the scope switch.
		F+T (Freeze+Trigger)	
		FRZ (Freeze)	
Remarks <ul style="list-style-type: none"> This setting is effective only when no freeze mode is registered in the doctor list. When the setting is changed, the scope switch settings are changed according to the settings in the Scope Switch Setup. 			
Scope Switch Setup	700 Scope	Setup	The submenu shown in Table 2 is displayed.
	500/600 Scope	Setup	
Remarks <ul style="list-style-type: none"> When the endoscope is connected, press each scope switch to ensure that the desired functions are assigned properly. When scope switch settings are performed again for the same type of endoscope, the previous settings are overwritten even if a different endoscope is connected. 			

Table 2

Category	Item	Value	Description
700 System Freeze Mode F/T F+T	1	→ “ <Functions to be assigned to the scope switch>”	The freeze mode “F/T” or “F+T” can be set. → “ • Assignments of 700 System (4-Switch) Scope”
	2		
	3		
	4		
700 System Freeze Mode FRZ	1	→ “ <Functions to be assigned to the scope switch>”	Only the freeze mode “FRZ” can be set. Assignment of “Trigger” is essential. → “ • Assignments of 700 System (4-Switch) Scope”
	2		
	3		
	4		
700/Z System Opt. Zoom Freeze Mode F/T F+T	1	→ “ <Functions to be assigned to the scope switch>”	The freeze mode “F/T” or “F+T” can be set. → “ • Assignments of 700 System (5-Switch) Scope”
	2		
	3		
	4		
	5		
	FR + OM (RC)	Not Assigned Trigger Record	
700/Z System Opt. Zoom Freeze Mode FRZ	1	→ “ <Functions to be assigned to the scope switch>”	Only the freeze mode “FRZ” can be set. Assignment of “Trigger” is essential. → “ • Assignments of 700 System (5-Switch) Scope”
	2		
	3		
	4		
	5		
	FR + OM (RC)	Not Assigned Trigger Record	
500 System 600 System	FR	→ “ <Functions to be assigned to the scope switch>”	→ “ • Assignments of Normal Scope”
	MM		
	RC		
500 System 600 System	1	→ “ <Functions to be assigned to the scope switch>”	→ “ • Assignments of Normal Scope”
	2		
	3		
	4		
600 System Opt. Zoom with SP SW	FR	→ “ <Functions to be assigned to the scope switch>”	→ “ • Assignments of Optical Zoom Scope”
	MM		
	SP		
	FR + OM (RC)		
500 System Ultrasonic	FR	→ “ <Functions to be assigned to the scope switch>”	→ “ • Assignments of Ultrasonic Endoscope”
	MM		
	RC		

Category	Item	Value	Description
500 System Ultrasonic	1	→ “ <Functions to be assigned to the scope switch>”	→ “ • Assignments of Ultrasonic Endoscope”
	2		
	3		
	4		
	5		

Note

- For the operations on the menu screen, refer to the description of basic system setup operations.
→ “4.2.2 Basic System Setup Operations”

<Functions to be assigned to the scope switch>

The functions in the following chart can be assigned to the scope switches of the endoscope used with this product. The setting is performed by service personnel.

Function	Description
F/T (Freeze / Trigger)	<p>When this switch is pressed, the observation screen displays a frozen image while displaying a video image on the sub-screen only during the period of the time set in the "Freeze Time".</p> <p>When this switch is pressed again while the image is frozen, the image is captured and then, the freeze mode is canceled.</p> <p>Note</p> <ul style="list-style-type: none"> • If the image is not frozen when this switch is pressed, the freeze mode is canceled without capturing the image. • The "Freeze Time" is set by service personnel.
F+T (Freeze + Trigger)	<p>When this switch is pressed, the observation screen displays a frozen image while displaying a video image on the sub-screen only during the period of the time set in the "Freeze Time".</p> <p>The image is captured automatically, and then the freeze mode is canceled. When this switch is pressed again while the image is frozen, the freeze mode is canceled without capturing the image.</p> <p>Note</p> <ul style="list-style-type: none"> • The "Freeze Time" is set by service personnel.
FRZ (Freeze)	<p>When this switch is pressed, the observation screen displays a frozen image while displaying a video image on the sub-screen.</p> <p>When this switch is pressed again while the image is frozen, the freeze mode is canceled without capturing the image. To capture it, press the switch assigned to "Trigger".</p> <p>Note</p> <ul style="list-style-type: none"> • Even if the switch to which "Record" is assigned is pressed after pressing the switch to which "Freeze" is assigned, the freeze mode is not canceled.
Trigger	<p>If this switch is pressed when the image on the observation screen is frozen, the image is captured, and then the freeze mode is canceled.</p> <p>Note</p> <ul style="list-style-type: none"> • If the image is not frozen, the image is not captured.

Function	Description
Record	<ul style="list-style-type: none"> If this switch is pressed when a video image is displayed, the observation screen displays the frozen image while displaying the video image on the sub-screen, and then, the frozen image is captured. After it is captured, the freeze mode is canceled. When the image is frozen by pressing the switch to which “F/T” or “F+T” is assigned, if this switch is pressed, the image is captured and the freeze mode is canceled. When the image is frozen by pressing the switch to which “FRZ” is assigned, if this switch is pressed, the image is captured but the freeze mode is not canceled.
Iris Mode	This switch changes the iris mode “AUTO/PEAK/AVE”.
Shutter Speed	<p>This switch changes the shutter speed set on the Shutter Speed Setup screen.</p> <p>→ “5.3.6 Setting the Shutter Speed”</p>
Obs. Mode Preset	<p>This switch changes the observation mode in the order specified on the Obs. Mode Preset Setup.</p> <p>→ “5.5.1 Registering, Calling Up and Editing and Deleting Image Setup Page - <Registering Image Setup Page> - Scope Common tab - Obs. Mode Preset Setup”</p>
Structure Emphasis	<p>This switch changes the ON/OFF of structure emphasis.</p> <p>→ “5.3.2 Structure Emphasis Settings”</p>
FICE	<p>This switch changes the ON/OFF of FICE.</p> <p>When a FICE set number is assigned in the “Simple FICE Setup” and FICE is “OFF”, each pressing of this switch changes the function to be selected in order of FICE “ON” and call up of FICE set number of “Assignment 1” → call up of “Assignment 2” → call up of “Assignment 3” → FICE “OFF”. The “Simple FICE Setup” is set by service personnel.</p> <p>→ “5.3.3 Setting FICE”</p>
Color Emphasis	<p>This switch turns the tone function ON/OFF.</p> <p>→ “5.3.4 Tone Settings”</p>
Display	<p>This switch is used to display or not to display the information on the observation screen.</p> <p>Note</p> <ul style="list-style-type: none"> When “Data Display Switching” is disabled, the function of this switch is also disabled.
Electronic Zoom	<p>When this switch is pressed, the display size changes to the size specified in “Zoom Ratio of Electronic Zoom”. When it is pressed again, the display size returns to the original size (zoom ratio: ×1.0).</p> <p>Note</p> <ul style="list-style-type: none"> The “Zoom Ratio of Electronic Zoom” is set by service personnel.

Function	Description
Optical Zoom: Zoom In	When an optical zoom scope is connected, this switch changes the zoom ratio of the optical zoom. This switch performs zoom-in only.
Optical Zoom: Zoom Out	When an optical zoom scope is connected, this switch changes the zoom ratio of the optical zoom. This switch performs zoom-out only.
SU Freeze	<p>When this switch is pressed, a freeze request is sent to the ultrasonic processor. This function is available only when “SU-1” is selected in the peripheral device setup.</p> <p>Note</p> <ul style="list-style-type: none"> This function cannot be assigned to the scope switches on endoscopes other than ultrasonic endoscopes.
SU Store	<p>When this switch is pressed, a store request is sent to the ultrasonic processor. This function is available only when “SU-1” is selected in the peripheral device setup.</p> <p>Note</p> <ul style="list-style-type: none"> This function cannot be assigned to the scope switches on endoscopes other than ultrasonic endoscopes.
Timer	<p>This switch starts or stops the timer.</p> <p>→ “7.17.2 Starting/Stopping the Timer”</p>
Lap Time	<p>When this switch is pressed, the lap time displayed on the observation screen is started/stopped/reset.</p> <p>→ “7.17.3 Lap Time Function”</p>
CAD Mode	<p>Computer-aided diagnosis mode of the EW1 System Software is switched.</p> <p>For details on the available endoscopes and operating method, refer to the operation manual of the EW1 System Software.</p>
Movie Recording (EX-WS)	<p>The movie recording function of the EW1 System Software is switched to ON/OFF.</p> <p>For details on the available endoscopes and operating method, refer to the operation manual of the EW1 System Software.</p>
Not Assigned	Assigns no function.

<Scope Switch Setting>

The functions available for each scope switch are described in the following chart.
The setting is performed by service personnel.

• Assignments of 700 System (5-Switch) Scope

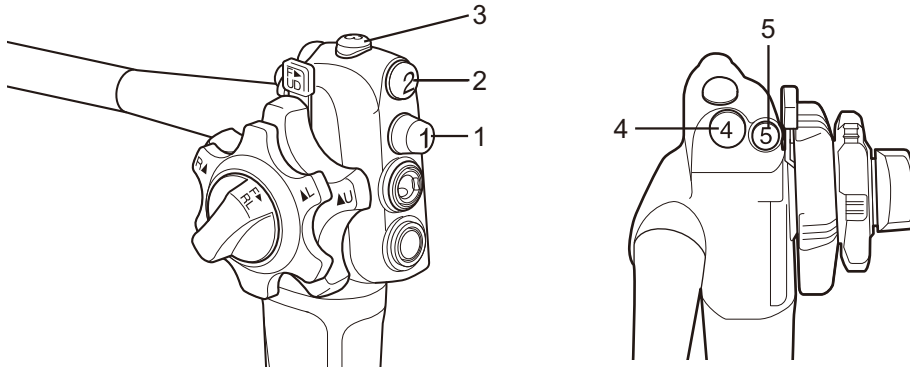

Function	1	2	3	4	5	FR+OM (RC)
F/T (Freeze / Trigger)	Yes	Yes	Yes	Yes	Yes	-
F+T (Freeze + Trigger)	Yes	Yes	Yes	Yes	Yes	-
FRZ (Freeze)	Yes	Yes	Yes	Yes	Yes	-
Trigger ^{*1}	Yes	Yes	Yes	Yes	Yes	Yes
Record ^{*1}	Yes	Yes	Yes	Yes	Yes	Yes
Iris Mode	Yes	Yes	Yes	Yes	Yes	-
Shutter Speed	Yes	Yes	Yes	Yes	Yes	-
Obs. Mode Preset	Yes	Yes	Yes	Yes	Yes	-
Structure Emphasis	Yes	Yes	Yes	Yes	Yes	-
FICE	Yes	Yes	Yes	Yes	Yes	-
Color Emphasis	Yes	Yes	Yes	Yes	Yes	-
Display	Yes	Yes	Yes	Yes	Yes	-
Electronic Zoom	Yes	Yes	Yes	Yes	Yes	-
Optical Zoom: Zoom In ^{*1}	Yes	Yes	Yes	Yes	Yes	-
Optical Zoom: Zoom Out ^{*1}	Yes	Yes	Yes	Yes	Yes	-
Timer	Yes	Yes	Yes	Yes	Yes	-
Lap Time	Yes	Yes	Yes	Yes	Yes	-
CAD Mode	Yes	Yes	Yes	Yes	Yes	-
Movie Recording (EX-WS)	Yes	Yes	Yes	Yes	Yes	-
Not Assigned	Yes	Yes	Yes	Yes	Yes	-

Yes: Available to assign

*1 The "Trigger" / "Record" and "Optical Zoom" functions can be assigned at the same time.

Note

- If “Freeze / Trigger”, “Freeze + Trigger” or “Freeze” and “Trigger” / “Record” are not assigned, images cannot be captured.

• **Assignments of 700 System (4-Switch) Scope**

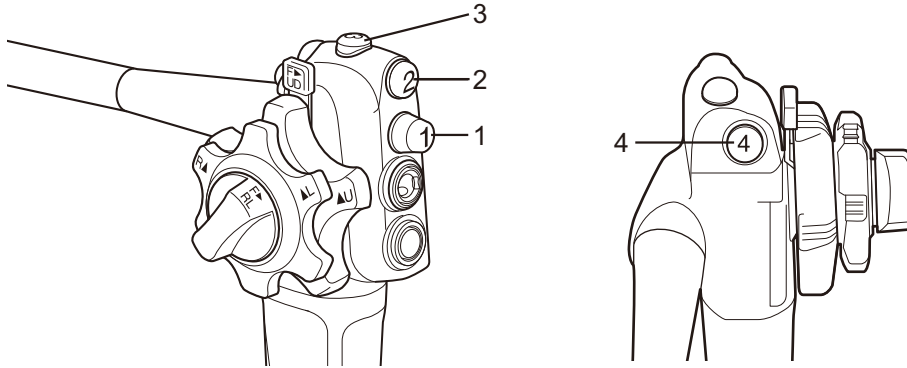

Function	1	2	3	4
F/T (Freeze / Trigger)	Yes	Yes	Yes	Yes
F+T (Freeze + Trigger)	Yes	Yes	Yes	Yes
FRZ (Freeze)	Yes	Yes	Yes	Yes
Trigger	Yes	Yes	Yes	Yes
Record	Yes	Yes	Yes	Yes
Iris Mode	Yes	Yes	Yes	Yes
Shutter Speed	Yes	Yes	Yes	Yes
Obs. Mode Preset	Yes	Yes	Yes	Yes
Structure Emphasis	Yes	Yes	Yes	Yes
FICE	Yes	Yes	Yes	Yes
Color Emphasis	Yes	Yes	Yes	Yes
Display	Yes	Yes	Yes	Yes
Electronic Zoom	Yes	Yes	Yes	Yes
Timer	Yes	Yes	Yes	Yes
Lap Time	Yes	Yes	Yes	Yes
CAD Mode	Yes	Yes	Yes	Yes
Movie Recording (EX-WS)	Yes	Yes	Yes	Yes
Not Assigned	Yes	Yes	Yes	Yes

Yes: Available to assign

Note

- If “Freeze / Trigger”, “Freeze + Trigger” or “Freeze” and “Trigger” / “Record” are not assigned, images cannot be captured.

• Assignments of Normal Scope

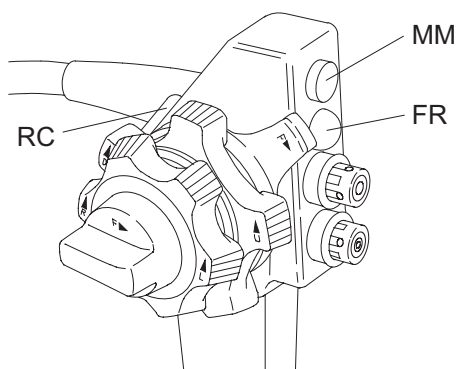

Function	FR	MM	RC
F/T (Freeze / Trigger)	Yes	-	Yes
F+T (Freeze + Trigger)	Yes	-	Yes
FRZ (Freeze)	Yes	-	Yes
Trigger	Yes	Yes	Yes
Record	-	Yes	Yes
Iris Mode	-	Yes	Yes
Shutter Speed	-	Yes	Yes
Obs. Mode Preset	-	Yes	Yes
Structure Emphasis	-	Yes	Yes
FICE	-	Yes	Yes
Color Emphasis	-	Yes	Yes
Display	-	Yes	Yes
Electronic Zoom	-	Yes	Yes
Timer	-	Yes	Yes
Lap Time	-	Yes	Yes
Movie Recording (EX-WS)	-	Yes	Yes
Not Assigned	-	Yes	Yes

Yes: Available to assign

Note

- For endoscopes without the MM scope switch, the assigned function does not operate, although it is displayed in the switch setting on the observation screen.
- When “Freeze” is set for “Freeze Mode” in the doctor list, if the trigger or record function is not assigned to the RC switch, the trigger function is automatically assigned to the RC switch.

• Assignments of Normal Scope (4-Switch Scope)

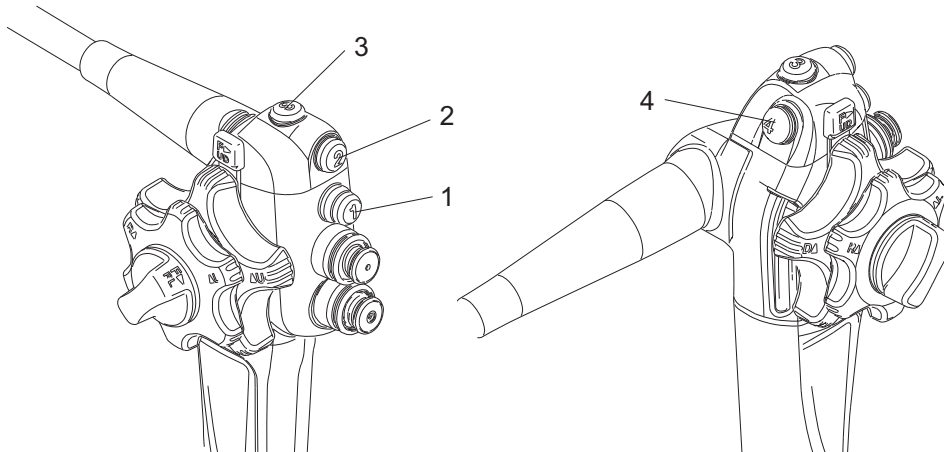

Function	1	2	3	4
F/T (Freeze / Trigger)	Yes	-	-	Yes
F+T (Freeze + Trigger)	Yes	-	-	Yes
FRZ (Freeze)	Yes	-	-	Yes
Trigger	Yes	Yes	Yes	Yes
Record	-	Yes	Yes	Yes
Iris Mode	-	Yes	Yes	Yes
Shutter Speed	-	Yes	Yes	Yes
Obs. Mode Preset	-	Yes	Yes	Yes
Structure Emphasis	-	Yes	Yes	Yes
FICE	-	Yes	Yes	Yes
Color Emphasis	-	Yes	Yes	Yes
Display	-	Yes	Yes	Yes
Electronic Zoom	-	Yes	Yes	Yes
Timer	-	Yes	Yes	Yes
Lap Time	-	Yes	Yes	Yes
Movie Recording (EX-WS)	-	Yes	Yes	Yes
Not Assigned	-	Yes	Yes	Yes

Yes: Available to assign

Note

- When “Freeze” is set for “Freeze Mode” in the doctor list, if the trigger or record function is not assigned to Switch 4, the trigger function is automatically assigned to Switch 4.

• Assignments of Optical Zoom Scope

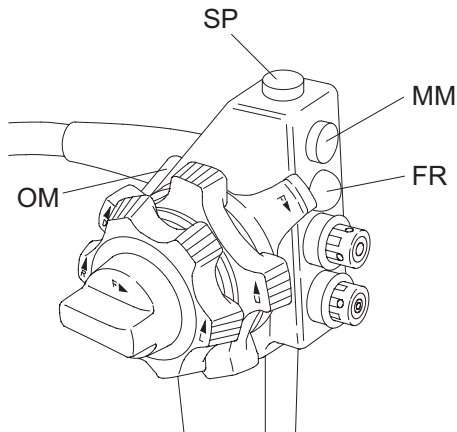

Note

- For the endoscopes without the SP switch, the functions for SP switch cannot be selected.

Function	FR	MM	SP	OM	FR+OM
F/T (Freeze / Trigger)	Yes	-	-	-	-
F+T (Freeze + Trigger)	Yes	-	-	-	-
FRZ (Freeze)	Yes	-	-	-	-
Trigger	-	Yes	Yes	-	Yes
Record	-	Yes	Yes	-	Yes
Iris Mode	-	Yes	Yes	-	-
Shutter Speed	-	Yes	Yes	-	-
Obs. Mode Preset	-	Yes	Yes	-	-
Structure Emphasis	-	Yes	Yes	-	-
FICE	-	Yes	Yes	-	-
Color Emphasis	-	Yes	Yes	-	-
Display	-	Yes	Yes	-	-
Electronic Zoom	-	Yes	Yes	-	-
Optical Zoom	-	-	-	Yes (exclusive use)	-
Timer	-	Yes	Yes	-	-
Lap Time	-	Yes	Yes	-	-
Movie Recording (EX-WS)	-	Yes	Yes	-	-
Not Assigned	-	Yes	Yes	-	-

Yes: Available to assign

Note

- When “Freeze” is set for “Freeze Mode” in the doctor list, if the trigger or record function is not assigned to FR+OM, the trigger function is automatically assigned to FR+OM.

• **Assignments of Ultrasonic Endoscope**

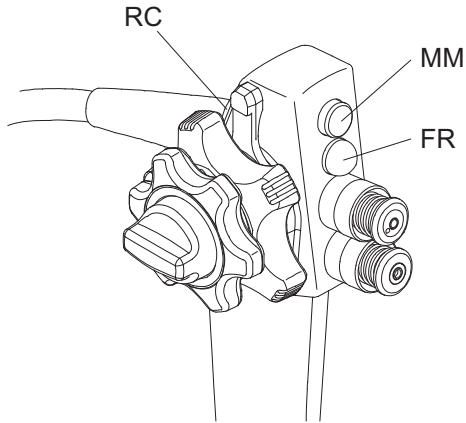

Function	FR	MM	SP
F/T (Freeze / Trigger)	Yes	-	Yes
F+T (Freeze + Trigger)	Yes	-	Yes
FRZ (Freeze)	Yes	-	Yes
Trigger	Yes	Yes	Yes
Record	-	Yes	Yes
Iris Mode	-	Yes	Yes
Shutter Speed	-	Yes	Yes
Structure Emphasis	-	Yes	Yes
FICE	-	Yes	Yes
Color Emphasis	-	Yes	Yes
Display	-	Yes	Yes
Electronic Zoom	-	Yes	Yes
SU Freeze	-	Yes	Yes
SU Store	-	Yes	Yes
Timer	-	Yes	Yes
Lap Time	-	Yes	Yes
Not Assigned	-	Yes	Yes

Yes: Available to assign

Note

- No ultrasonic endoscope supports the Obs. Mode Preset function.

• Assignments of Ultrasonic Endoscope (5-Switch Scope)

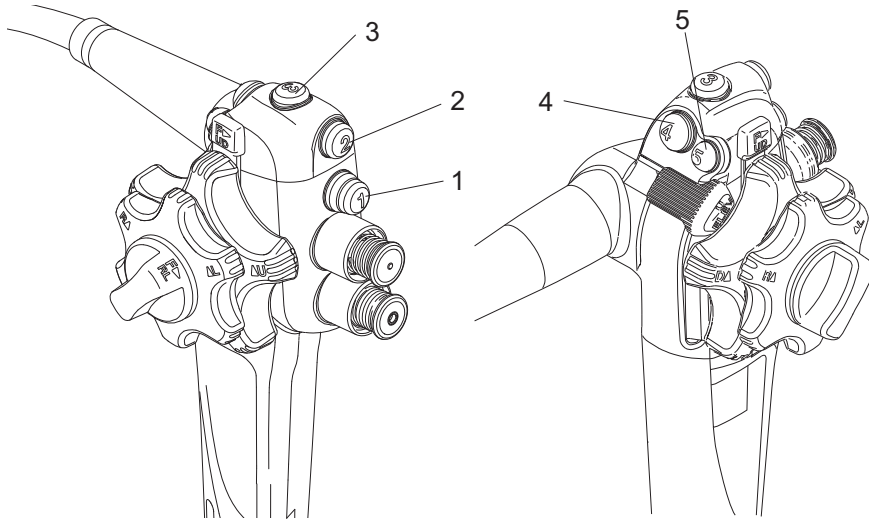

Function	1	2	3	4	5
F/T (Freeze / Trigger)	Yes	-	-	Yes	-
F+T (Freeze + Trigger)	Yes	-	-	Yes	-
FRZ (Freeze)	Yes	-	-	Yes	-
Trigger	Yes	Yes	Yes	Yes	Yes
Record	-	Yes	Yes	Yes	Yes
Iris Mode	-	Yes	Yes	Yes	Yes
Shutter Speed	-	Yes	Yes	Yes	Yes
Structure Emphasis	-	Yes	Yes	Yes	Yes
FICE	-	Yes	Yes	Yes	Yes
Color Emphasis	-	Yes	Yes	Yes	Yes
Display	-	Yes	Yes	Yes	Yes
Electronic Zoom	-	Yes	Yes	Yes	Yes
SU Freeze	-	Yes	Yes	Yes	Yes
SU Store	-	Yes	Yes	Yes	Yes
Timer	-	Yes	Yes	Yes	Yes
Lap Time	-	Yes	Yes	Yes	Yes
Not Assigned	-	Yes	Yes	Yes	Yes

Yes: Available to assign

Note

- No ultrasonic endoscope supports the Obs. Mode Preset function.

4.2.8 Setting Foot Switch (FS1)

<Functions to be assigned to the foot switch (FS1)>

The functions in the following chart can be assigned to the foot switch of the endoscope connected to this product. When the function needs to be changed, consult your local FUJIFILM dealer.

Function	Description
F/T, F+T, FRZ	When this switch is pressed, the same function assigned to the Freeze switch of the scope switch will operate. → “4.2.7 Endoscope Tab”
Trigger	If this switch is pressed when the image on the observation screen is frozen, the image is captured, and then the freeze mode is canceled. Note • If the image is not frozen, the image is not captured.
Record	If this switch is pressed when the image on the observation screen is frozen, the image is captured, and then the freeze mode is canceled. Note • If this switch is pressed when a video image is displayed, the observation screen displays the frozen image while displaying the video image on the sub-screen, and then, the frozen image is captured. After the image is captured, the freeze mode is canceled.
Iris Mode	This switch changes the iris mode (AUTO/PEAK/AVE).
Shutter Speed	This switch changes the shutter speed (Standard/High) set on the Shutter Speed Setup screen. → “5.3.6 Setting the Shutter Speed”
Structure Emphasis	This switch turns the structure emphasis ON/OFF. → “5.3.2 Structure Emphasis Settings”
FICE	When a FICE set number is assigned in the “Simple FICE Setup” and FICE is “OFF”, each press of this switch changes the function to be selected in order of FICE “ON” and call up of FICE set number of “Assignment 1” → call up of “Assignment 2” → call up of “Assignment 3” → FICE “OFF”. → “5.3.3 Setting FICE”
Color Emphasis	This switch turns the tone function ON/OFF. → “5.3.4 Tone Settings”
Display	This switch is used to display or not to display the information on the observation screen. Note • When “Data Display Switching” is disabled, the function of this switch is also disabled.

Function	Description
Electronic Zoom: Zoom In *1	This switch changes the zoom ratio of the electronic zoom. The ratio changes each 0.05 steps from the range of $\times 1.00$ to $\times 2.00$. This switch performs zoom-in only.
Electronic Zoom: Zoom Out *1	This switch changes the zoom ratio of the electronic zoom. The ratio changes each 0.05 steps from the range of $\times 1.00$ to $\times 2.00$. This switch performs zoom-out only.
Optical Zoom: Zoom In	When an optical zoom scope is connected, this switch changes the zoom ratio of the optical zoom. This switch performs zoom-in only.
Optical Zoom: Zoom Out	When an optical zoom scope is connected, this switch changes the zoom ratio of the optical zoom. This switch performs zoom-out only.
PinP Sub-screen Position Switching	If this switch is pressed when the observation screen displays a frozen image while displaying the video image on the sub-screen, the sub-screen changes its display position in order of the upper left \rightarrow upper right \rightarrow lower right \rightarrow lower left.
Hide / Display Sub-screen	When the observation screen displays a frozen image while displaying the video image on the sub-screen, pressing of this switch hides the sub-screen. To re-display the sub-screen, press this switch again.
Obs. Mode Preset	This switch changes the observation mode in the order specified on the Obs. Mode Preset Setup. → "5.5.1 Registering, Calling Up and Editing and Deleting Image Setup Page - <Registering Image Setup Page> - Scope Common tab - Obs. Mode Preset Setup"
CAD Mode	Computer-aided diagnosis mode of the EW1 System Software is switched. For details on the available endoscopes and operating method, refer to the operation manual of the EW1 System Software.
Movie Recording (EX-WS)	The movie recording function of the EW1 System Software is switched to ON/OFF. For details on the available endoscopes and operating method, refer to the operation manual of the EW1 System Software.
Not Assigned	Assigns no function.

*1 The zoom ratio of some 530 series scopes is $\times 1.00$ to $\times 1.95$

Setting Foot Switch (FS1)

The functions available for each part of the foot switch are described in the following chart.

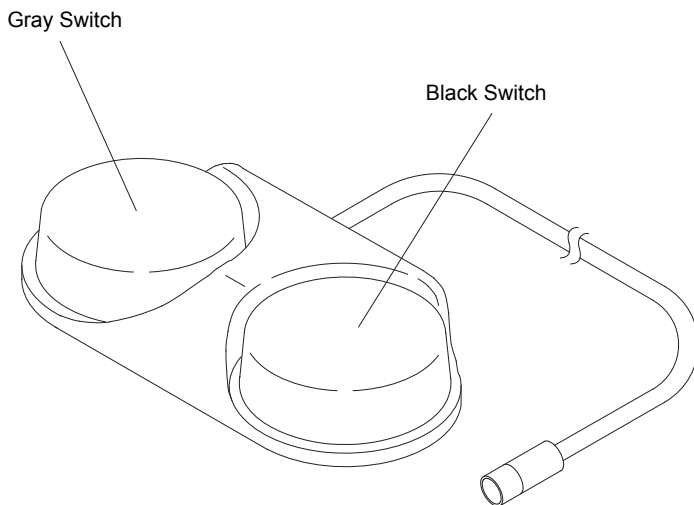

Note

- For the endoscopes without the SP switch, the functions for SP switch cannot be selected.

Function	Gray	Black
F/T, F+T, FRZ	Yes	Yes
Trigger	Yes	Yes
Record	Yes	Yes
Iris Mode	Yes	Yes
Shutter Speed	Yes	Yes
Structure Emphasis	Yes	Yes
FICE	Yes	Yes
Color Emphasis	Yes	Yes
Display	Yes	Yes
Electronic Zoom: Zoom In	Yes	Yes
Electronic Zoom: Zoom Out	Yes	Yes
Optical Zoom: Zoom In	Yes	Yes
Optical Zoom: Zoom Out	Yes	Yes
PinP Sub-screen Position Switching	Yes	Yes
Hide / Display Sub-screen	Yes	Yes
Obs. Mode Preset	Yes	Yes
CAD Mode	Yes	Yes
Movie Recording (EX-WS)	Yes	Yes
Not Assigned	Yes	Yes

Yes: Available to assign

4.2.9 Setup for Switching the Shutter Speed During Optical Zoom

When an optical zoom scope is connected, the shutter speed at the optical zoom can be switched automatically.

The switching methods are described below. The switching method (Auto/Auto 2/Manual) and the OM max. value are set by service personnel at the time of installation.

Auto	When the optical zoom is in maximum, the shutter speed is changed to the speed set for the optical zoom.
Auto 2	In a general observation (when not using the optical zoom), the shutter speed is a standard speed. When the position of the optical zoom is placed in "Far Position" of "Optical Zoom Setup", the shutter speed is the speed set for the optical zoom. When the position of the optical zoom is placed in "Near Position" of "Optical Zoom Setup", the shutter speed is the speed according to the OM max. value.
Manual	When using the optical zoom, the shutter speed does not change automatically. Switching is performed by pressing the button to which "Shutter speed" has been assigned.

Note

- When the switching method is Auto or Auto 2 and an optical zoom scope is connected, if the zoom switch is pressed while the optical zoom ratio is in maximum, the zoom changes to the electronic zoom automatically.

4.2.10 Setting the Doctor's Name

This section describes the method of registering a doctor's name in the doctor list, and also the method of deleting a registered doctor's name. The registered doctor's name can be selected when registering patient information. For registering patient information, refer to "5.2.1 Registering Patient Information".

<Registering a Doctor's Name>

Up to 20 doctors' names can be registered.

- (1) Press the [Doctor] key.

The Doctor List screen appears.

To turn the pages, move the cursor to "Doctor List 1/2 (or 2/2)" and then press the [←] or [→] key.

The screenshot shows the 'Doctor List' screen. At the top, there is a title bar with a menu icon and the text 'Doctor List'. Below the title bar, there are two navigation buttons: 'Doctor List 1/2' with left and right arrows, and 'Image setting'. The main area contains a table with the following columns: 'No.', 'Doctor Name', 'Freeze Mode', 'Upper GI', 'Lower GI', and 'Others'. The 'No.' column contains numbers from 01 to 10. Below the table, there is another 'Doctor List 1/2' navigation button and a 'Delete all listed data' button. At the bottom, there is a keyboard legend: [F1] Move [Enter] Select [Insert] Edit [Delete] Delete [Esc] Cancel.

- (2) Move the cursor to the number of the doctor's name to be registered and press the [Insert] key. Now the system is ready for the doctor's name to be entered.

The screenshot shows the 'Doctor List' screen, similar to the previous one. However, the row corresponding to 'No. 01' is highlighted with a grey background, indicating that the cursor is positioned on this row. The rest of the screen, including the navigation buttons and keyboard legend, remains the same.

(3) Enter the doctor's name, using up to 20 characters.

Doctor List 1/2		Image setting			
No.	Doctor Name	Freeze Mode	Upper GI	Lower GI	Others
01	AOYAMA				
02					
03					
04					
05					
06					
07					
08					
09					
10					

Doctor List 1/2

Delete all listed data

[] [] Move [Enter] Select [Insert] Edit [Delete] Delete [Esc] Cancel

(4) When entry of the doctor name is completed, press the [Enter] key. When a pop-up menu is displayed, select "None" or the function to be assigned to the freeze mode.

Note

- The function selected in "Freeze Mode" is regarded as a doctor-specific function giving it a priority over the setting performed by service personnel.
- When "Freeze" is selected in "Freeze Mode"
If the 600 system scope or 500 system scope, except the ultrasonic endoscope, is connected but the trigger or record function is not assigned to the RC switch or Switch 4 on the endoscope, the trigger function is automatically assigned to the RC switch or Switch 4.
- For 700 system scopes, if "Freeze / Trigger", "Freeze + Trigger" or "Freeze" and "Trigger" / "Record" are not assigned, images cannot be captured.

➔ "4.2.7 Endoscope Tab"

Doctor List 1/2		Image setting			
No.	Doctor Name	Freeze Mode	Upper GI	Lower GI	Others
01	AOYAMA	None			
02		F/T (Freeze/Trigger)			
03		F+T (Freeze+Trigger)			
04		FRZ (Freeze)			
05					
06					
07					
08					
09					
10					

Doctor List 1/2

Delete all listed data

[] [] Move [Enter] Select [Insert] Edit [Delete] Delete [Esc] Cancel

- (5) Select the image setting. By selecting the image setting according to the target region of endoscopic observation, the appropriate image setting is loaded at the time of starting the examination. When a pop-up menu is displayed, select “* None” or an already registered image setup page name.

Upper GI: Endoscope whose name begins with “EG”

Lower GI: Endoscope whose name begins with “EC”

Others: Other than above

→ “5.5.1 Registering, Calling Up and Editing and Deleting Image Setup Page”

Note

- Items that can be selected in “Image setting” are image setting page names registered on the Image Setup Page screen.

The screenshot shows the 'Doctor List' screen with a table of doctor information and a pop-up menu for 'Image setting'.

No.	Doctor Name	Freeze Mode	Upper GI	Lower GI	Others
01	AOYAMA	F/T(Freeze/Trigger)			
02					
03					
04					
05					
06					
07					
08					
09					
10					

The 'Image setting' pop-up menu is open, showing the following options:

- * None
- 01 Upper GI recommend
- 02 Lower GI recommend
- 03 Blur Decreast 0.3s
- 04 NR Medium

At the bottom of the screen, there is a button labeled 'Delete all listed data' and a status bar with the text: [1] [1] Move [Enter] Select [Insert] Edit [Delete] Delete [Esc] Cancel

- (6) When registering two or more doctor’s names, repeat steps (2) to (5).
- (7) Once you have entered all of the doctor’s names, select a doctor name and press the [Enter] key.

The settings for the selected doctor are called up and operation returns to the observation screen.

To return to the observation screen without the settings called up, press the [Esc] key.

The screenshot shows the 'Doctor List' screen with a table of doctor information. The second row is highlighted.

No.	Doctor Name	Freeze Mode	Upper GI	Lower GI	Others
01	AOYAMA				
02	SHIBUYA	F/T(Freeze/Trigger)			
03	SHINAGAWA	F+T(Freeze+Trigger)			
04					
05					
06					
07					
08					
09					
10					

At the bottom of the screen, there is a button labeled 'Delete all listed data' and a status bar with the text: [1] [1] Move [Enter] Select [Insert] Edit [Delete] Delete [Esc] Cancel

<Deleting a Doctor's Name>

- (1) Press the [Doctor] key.

The Doctor List screen appears.

To turn the pages, move the cursor to "Doctor List 1/2 (or 2/2)" and then press the [←] or [→] key.

The screenshot shows the "Doctor List" screen with a table of doctor information. The table has columns for No., Doctor Name, Freeze Mode, Upper GI, Lower GI, and Others. The rows are numbered 01 to 10. The current page is "Doctor List 1/2".

No.	Doctor Name	Freeze Mode	Upper GI	Lower GI	Others
01	AOYAMA				
02	SHIBUYA	F/T (Freeze/Trigger)			
03	SHINAGAWA	F+T (Freeze+Trigger)			
04					
05					
06					
07					
08					
09					
10					

At the bottom of the screen, there is a "Delete all listed data" button and a status bar with the text: [1] [1] Move [Enter] Select [Insert] Edit [Delete] Delete [Esc] Cancel

- (2) Move the cursor to the number of the doctor's name to be deleted and press the [Delete] key.
The confirmation message "This doctor information will be deleted. OK?" appears.

The screenshot shows the "Doctor List" screen with a confirmation dialog box overlaid. The dialog box contains the text: "This doctor information will be deleted. OK?" and has "No" and "Yes" buttons. The cursor is positioned on the number "02" in the table.

No.	Doctor Name	Freeze Mode	Upper GI	Lower GI	Others
01	AOYAMA				
02	SHIBUYA	F/T (Freeze/Trigger)			
03	SHINAGAWA	F+T (Freeze+Trigger)			
04					
05					
06					
07					
08					
09					
10					

At the bottom of the screen, there is a "Delete all listed data" button and a status bar with the text: [1] [1] Move [Enter] Select [Insert] Edit [Delete] Delete [Esc] Cancel

- (3) When “Yes” is selected, the selected doctor’s name is deleted.
The deleted list is left blank.

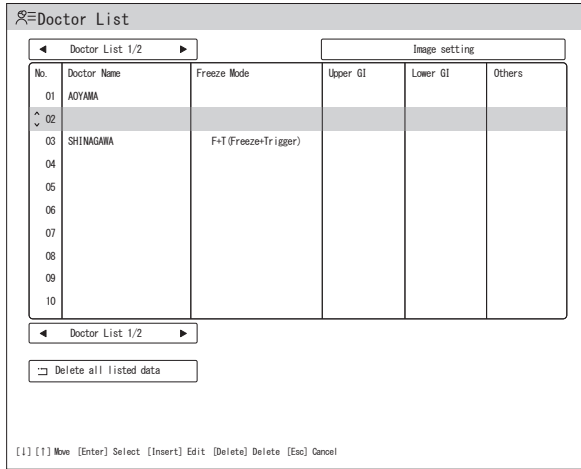

Note

- When deleting all doctors’ names, move the cursor to “Delete all listed data” and press the [Enter] key. The confirmation message “All doctor information will be deleted. OK?” appears.

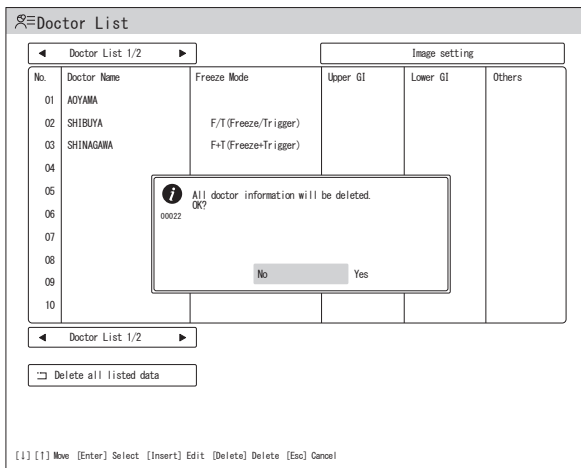

- (4) Press the [Enter] key.
The selected doctor’s name is called up and operation returns to the observation screen.
To return to the observation screen without the doctor’s name called up, press the [Esc] key.

4.2.11 Setting the Procedure Name

This section describes the method of registering a procedure name in the procedure list, and also the method of deleting a registered procedure.

The registered procedure name can be selected when registering patient information.

For registering patient information, refer to “5.2.1 Registering Patient Information”.

<Registering a Procedure Name>

Up to 20 types of procedure names can be registered.

- (1) Press the [Case] key.

The Procedure List screen appears.

To turn the pages, move the cursor to “Procedure List 1/2 (or 2/2)” and then press the [←] or [→] key.

The screenshot shows a window titled "Procedure List" with a sub-header "Procedure List 1/2". It contains a table with two columns: "No." and "Procedure Name". The "No." column lists numbers from 01 to 10. The "Procedure Name" column is empty. Below the table are navigation arrows and a "Delete all listed data" button. At the bottom, a status bar shows keyboard shortcuts: [] [] Move [Enter] Select [Insert] Edit [Delete] Delete [Esc] Cancel.

- (2) Move the cursor to the list number of the procedure name to be registered and press the [Insert] key.

Now the system is ready for the procedure name to be entered.

Note

- When the [Enter] key is pressed, the selected procedure name is called up and operation returns to the observation screen. If no procedure name is registered, the screen display remains unchanged even when the [Enter] key is pressed.

This screenshot is identical to the previous one, but the row with number "01" in the "No." column is highlighted with a grey background, indicating it is selected for registration.

- (3) Enter a procedure name using up to 16 characters and press the [Enter] key.

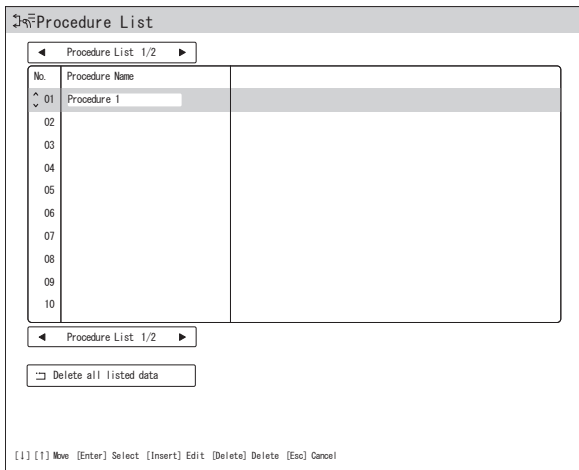

- (4) When registering two or more procedure names, repeat steps (2) to (3).
- (5) Once you have entered all of the procedure names, select a procedure name and press the [Enter] key.
 The selected procedure name is called up and operation returns to the observation screen.
 To return to the observation screen without the procedure name called up, press the [Esc] key.

<Deleting a Procedure Name>

- (1) Press the [Case] key.
 The Procedure List screen appears. To turn the pages, move the cursor to "Procedure List 1/2 (or 2/2)" and then press the [←] or [→] key.

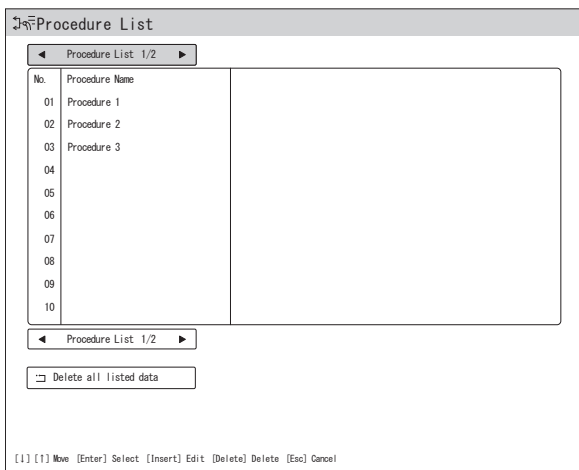

- (2) Move the cursor to the list number of the procedure name to be deleted and press the [Delete] key.

The confirmation message “This procedure information will be deleted. OK?” appears.

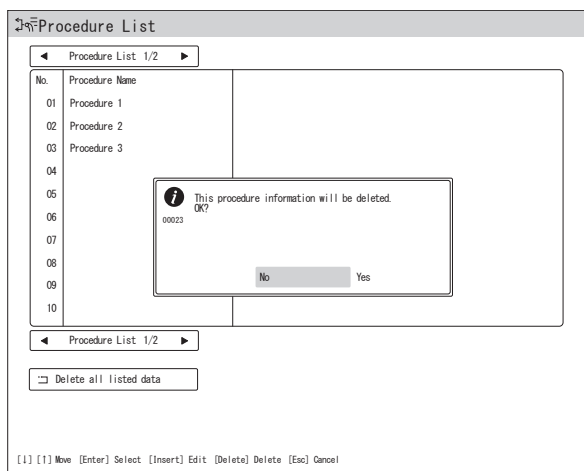

- (3) When “Yes” is selected, the selected procedure name is deleted.

“Procedure Name” for the deleted list is left blank.

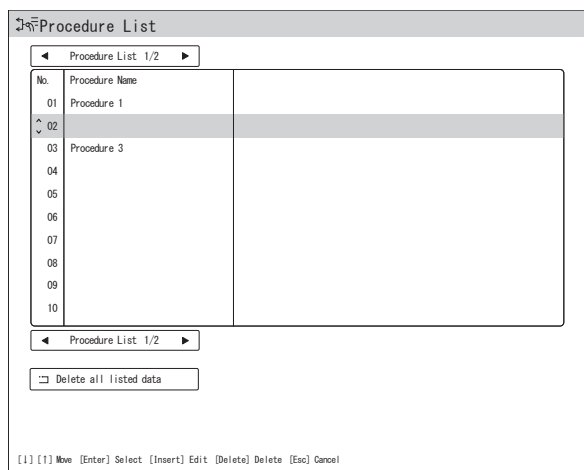

Note

- When deleting all procedure names, move the cursor to “Delete all listed data” and press the [Enter] key.

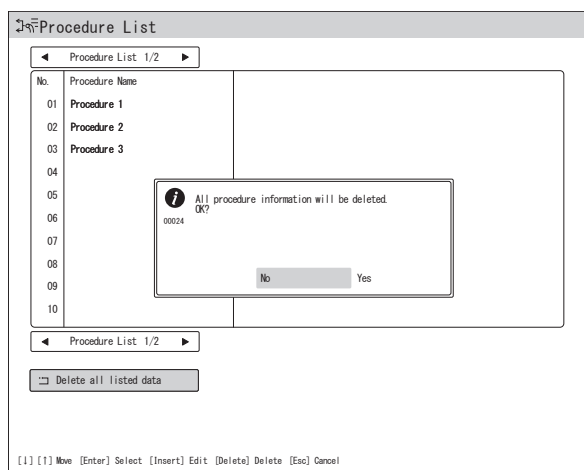

- (4) Press the [Esc] key.
Operation returns to the observation screen.

4.2.12 Setting the Message

Messages to be added to patient information can be registered.

<Registering a Message>

Up to 20 types of messages can be registered.

- (1) Press the [Message] key.

The Message List screen appears.

To turn the pages, move the cursor to “Message List 1/2 (or 2/2)” and then press the [←] or [→] key.

The screenshot shows a window titled "Message List". At the top, there is a navigation bar with "Message List 1/2" and left/right arrow buttons. Below this is a table with two columns: "No." and "Message". The "No." column contains numbers 01 through 10. The "Message" column is empty. Below the table, there is another navigation bar with "Message List 1/2" and arrow buttons, and a button labeled "Delete all listed data". At the bottom, there is a status bar with the text: "[1] [1] Move [Insert] Edit [Delete] Delete [Esc] Cancel".

- (2) Move the cursor to the list number of the message to be registered and press the [Insert] key. Now the system is ready for the message to be entered.

This screenshot is identical to the previous one, but the cursor is now positioned on the first row of the table, where "No." is 01. The "Message" column for row 01 is highlighted, indicating it is selected for editing.

- (3) Enter a message using up to 20 characters and press the [Enter] key.

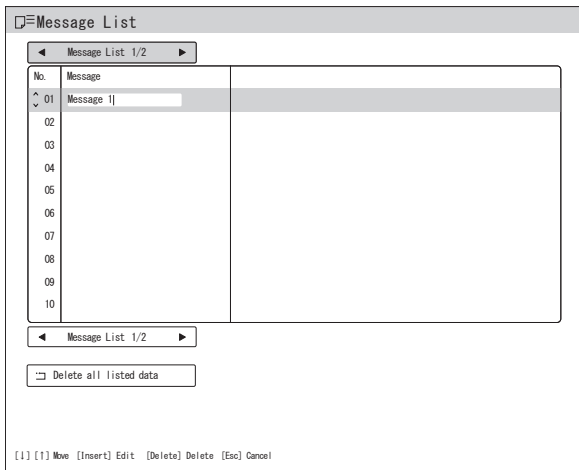

- (4) When registering two or more messages, repeat steps (2) to (3).
 (5) Press the [Esc] key.
 Operation returns to the observation screen.

<Deleting a Message>

- (1) Press the [Message] key.
 The Message List screen appears. To turn the pages, move the cursor to “Message List 1/2 (or 2/2)” and then press the [←] or [→] key.

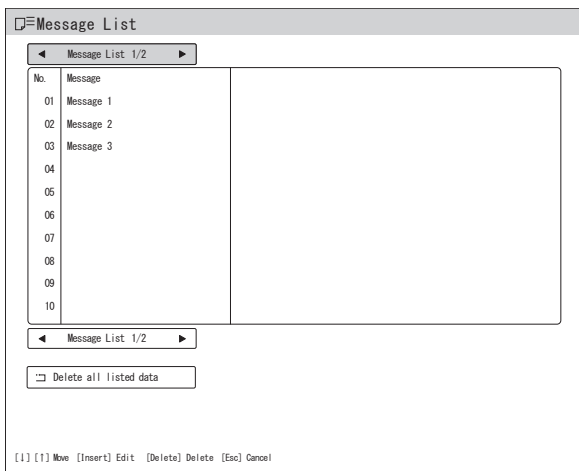

- (2) Move the cursor to the list number of the message to be deleted and press the [Delete] key. The confirmation message “This message will be deleted. OK?” appears.

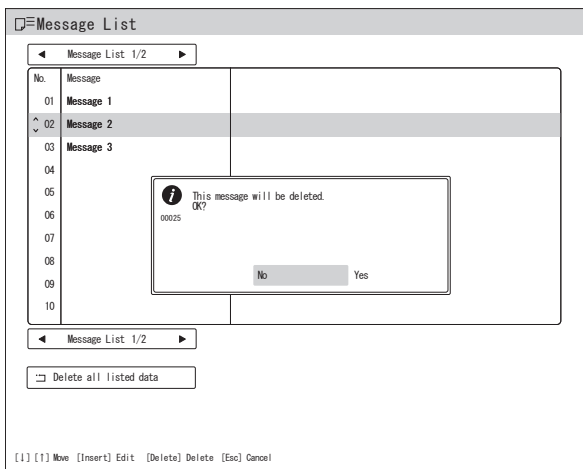

- (3) When “Yes” is selected, the selected message is deleted. “Message” for the deleted list is left blank.

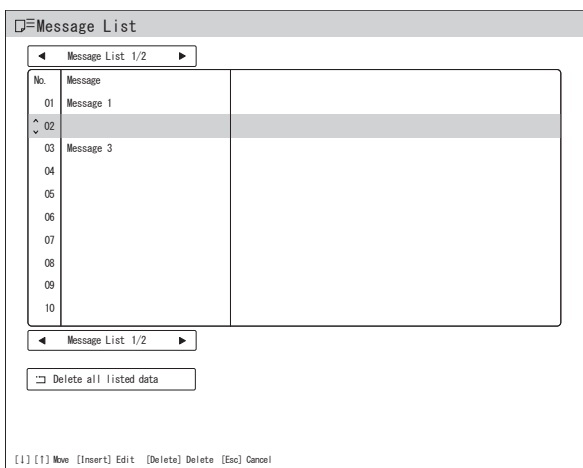

Note

- When deleting all messages, move the cursor to “Delete all listed data” and press the [Enter] key.

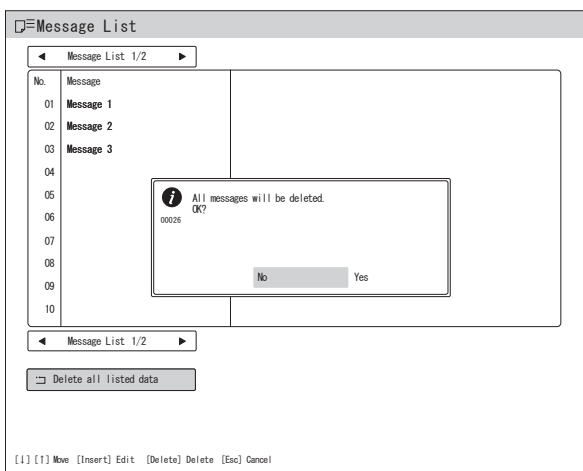

- (4) Press the [Esc] key.
Operation returns to the observation screen.

4.3 Security Function

CAUTION

- Once the user logs in to the security function, all the information can be accessed until the user logs off the security function or turns off the system. When stepping away from the system, be sure to log off the security function or turn off the system.
- If you forgot the login password and cannot log in to the security function, consult your local FUJIFILM dealer.

To prevent information leakage to third parties, the login authentication screen requesting the login password can be displayed when accessing personal information of the patient or information on system settings.

Two kinds of login passwords, the login password for the user, and the one for the administrator can be set. Only the administrator can perform security settings.

➔ “4.3.1 Access Control with the Security Function”

The default login password for the user is “user”, and the default login password for the administrator is “user1”. Change each login password when logging in to this product for the first time.

➔ “4.3.2 Logging in to the Security Function (Changing the Password)”

Note

- Take care not to forget the changed password. To protect personal information of the patient, change the password regularly.

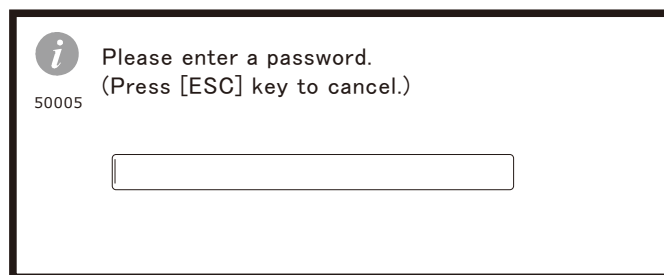

Once the user or administrator logs in to the security function, the icon indicating the login state is displayed on the observation screen.

➔ “3.9 Data Display on the Observation Screen”

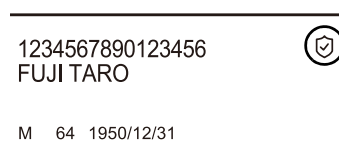

Full HD mode

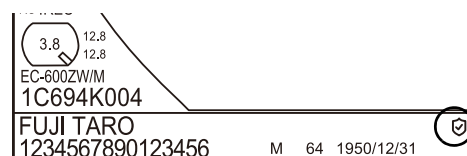

SXGA mode

4.3.1 Access Control with the Security Function

Only the administrator can change the security settings.

When the login authentication screen appears, log in to the security function by entering the login password for the administrator.

Press the [System] key on the keyboard. The System Setup screen appears. Select “Security” on the “Basic setting” tab and press the [Enter] key. Switch to the “Limitation” tab.

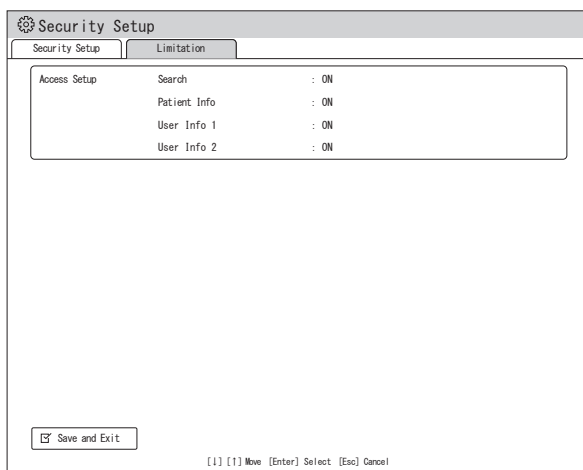

Category	Item	Value	Description
Access Setup	Search	ON	Select ON/OFF of the security function for the items set by using the [Start] or [Search] key, and for the operation described in <How to copy daily exam data>.
		OFF	
	Patient Info	ON	Select ON/OFF of the security function for the items set by using the [Patient] key.
		OFF	
	User Info 1	ON	Select ON/OFF of the security function for the items set by using the [Doctor], [System], [Peripherals] or [Image] key.
		OFF	
	User Info 2	ON	Select ON/OFF of the security function for the items set by using the [Case] or [Message] key.
		OFF	

Note

- For the operations on the menu screen, refer to the description of basic system setup operations.

→ “4.2.2 Basic System Setup Operations”

4.3.2 Logging in to the Security Function (Changing the Password)

CAUTION

- If you forgot the login password and cannot log in to the security function, consult your local FUJIFILM dealer.

Press the [System] key on the keyboard. The System Setup screen appears. Select “Security” on the “Basic setting” tab and press the [Enter] key. Switch to the “Security Setup” tab.

When the password for the user is entered at the time of logging in to the security function, only “User Password” can be changed. When the password for the administrator is entered, “User Password” and “Admin Password” can be changed.

The default login password for the user is “user”, and the default login password for the administrator is “user1”.

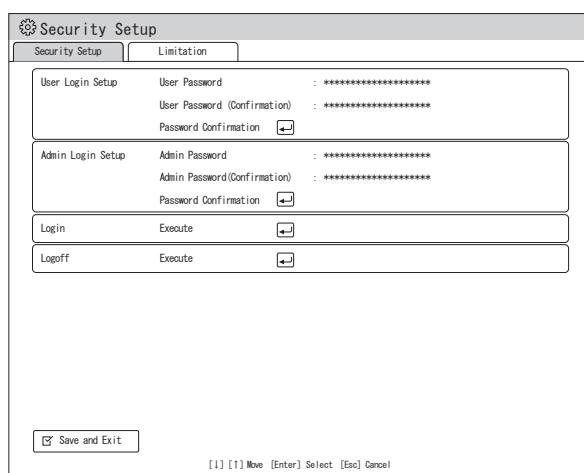

Category	Item	Description
User Login Setup	User Password	The password must be between 5 to 15 characters in length. Alphanumeric characters and symbols can be used.
	User Password (Confirmation)	Enter the new password again.
	Password Confirmation	After entering the new password in “User Password” and “User Password (Confirmation)”, press the [Enter] key to change the password.
Admin Login Setup	Admin Password	The password must be between 5 to 15 characters in length. Alphanumeric characters and symbols can be used.
	Admin Password (Confirmation)	Enter the new password again.
	Password Confirmation	After entering the new password in “Admin Password” and “Admin Password (Confirmation)”, press the [Enter] key to change the password.
Login	Execute	Select “Login” and press the [Enter] key to log in to the security function. Login enables the security function and allows the change of the login password for the user or the administrator.

Category	Item	Description
Logoff	Execute	→ “4.3.3 Logging off the Security Function”

Note

- For the operations on the menu screen, refer to the description of basic system setup operations.

→ “4.2.2 Basic System Setup Operations”

4.3.3 Logging off the Security Function

CAUTION

- Once the user logs in to the security function, all the information can be accessed until the user logs off the security function or turns off the system. When stepping away from the system, be sure to log off the security function or turn off the system.

Press the [System] key on the keyboard. The System Setup screen appears. Select “Security” on the “Basic setting” tab and press the [Enter] key. Switch to the “Security Setup” tab.

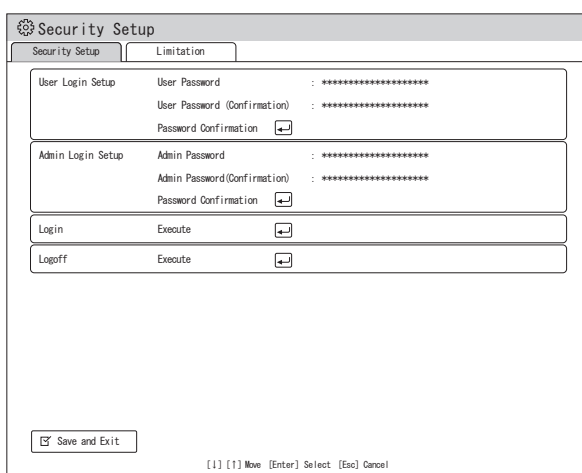

Select “Logoff” and press the [Enter] key. When the logoff sequence is completed, select “Save and Exit” and press the [Enter] key. Ensure that the icon indicating the login state disappears from the observation screen.

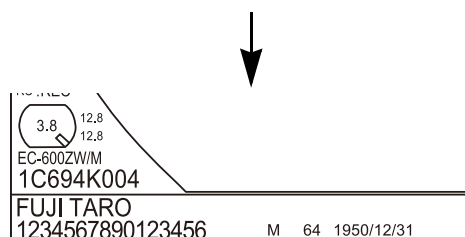
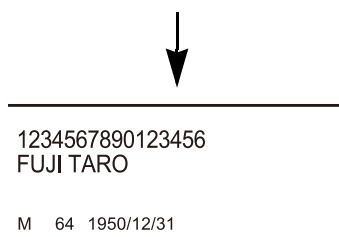
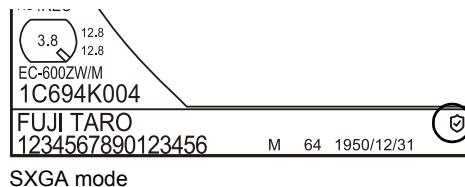
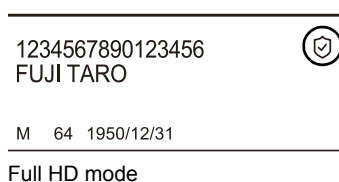

Note

- For the operations on the menu screen, refer to the description of basic system setup operations.
- ➔ “4.2.2 Basic System Setup Operations”

5.1 Hierarchical Structure of the Setting Screens

Note

- Setting screens are displayed on the monitor connected to the DVI-D connector.
- While a setting screen is displayed, the message “Displaying menu” appears on the monitor connected to RGB TV, Video or S Video connector.

If you press a function key, the setting screen assigned to the key is displayed. The hierarchy of each key and setting screen is structured as described below.

<[Patient Entry] Key>

Patient Information Entry screen (Patient No. Auto Entry)

<[Patient] Key>

Patient List screen

No.	Name	ID
01	FUJII TAROU	123456
02	TANAKA ICHIROU	123457
03	SUZUKI KENICHI	123458
04		
05		
06		
07		
08		
09		
10		
11		
12		
13		
14		
15		

<[Doctor] Key>

Doctor List screen

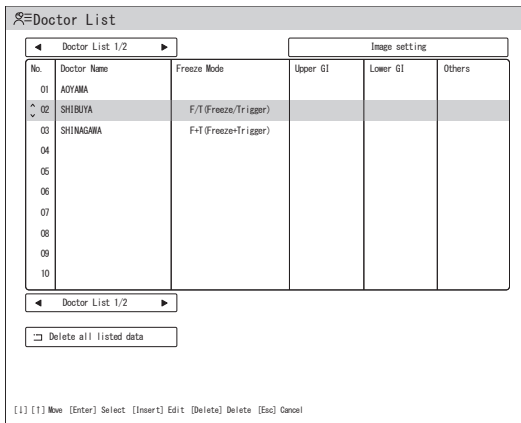

<[Case] Key>

Procedure List screen

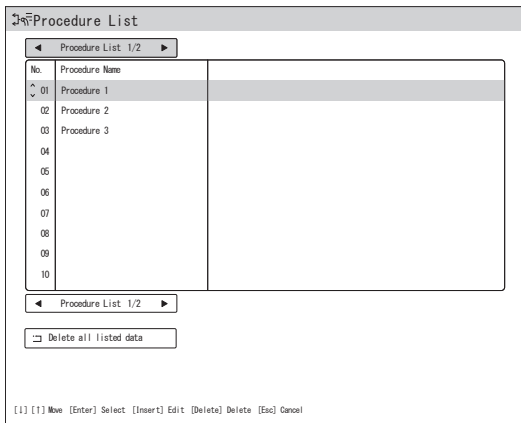

<[Note] Key>

Displays no setting screen.
 (Makes it possible to enter comments on the observation screen.)

<[Message] Key>

Message List screen

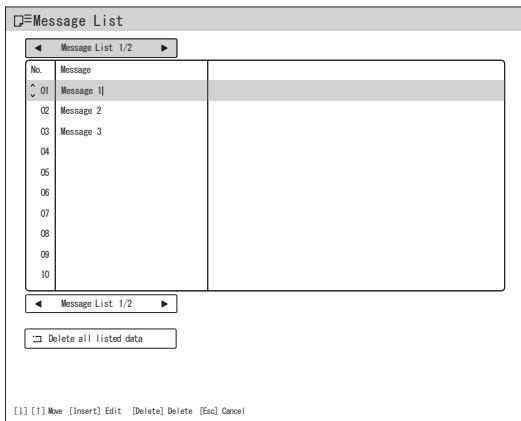

<[System] Key>

System Setup screen

System Setup		
Function	Display	Basic setting
Displayed Info.	MaskType	: Type 1
Multi	Multi Button	: Light Limit
	Multi Key	: Mask Type
Index images	Index	: ON
Zoom Setup	Multi Zoom Mode	: Continuous

Save and Exit

[] [] Move [Enter] Select [Esc] Cancel

System Setup		
Function	Display	Basic setting
Displayed Info.	Exam. Data	: Patient ID
	Exam. Info.	: ON
Space Key	Screen display switching	: Patient info. OFF
Lap Time Setup	Lap Time	: OFF
Hospital Name	Hospital Name	:
Scope Info.	Priority Scope Information	: Distal End
EX-MS	Setup	<input type="checkbox"/>

Save and Exit

[] [] Move [Enter] Select [Esc] Cancel

System Setup		
Function	Display	Basic setting
Date/Time Set	Date	: 2015 / 01 / 01
	Date Mode	: Y/M/D
	Time Setup	: 00 : 03 : 25
	Time Mode	: 12-hour
	Time Zone	: GMT + 9 Time
Screen Setup	Screen Resolution	: SIGA
Volume Setup	Volume	: Mid
	Optical zoom SW sound	: ON
Timer Setup	Timer	: Timer Start/Stop
Security	Setup	<input type="checkbox"/>

Save and Exit

[] [] Move [Enter] Select [Esc] Cancel

System Setup		
Function	Display	Basic setting
Pump	Pump Level	: H
	Pump Off (minute)	: 5
Light Save function	Linkage	: ON
	Brightness Level	: <input type="text" value=""/> -2

Save and Exit

[] [] Move [Enter] Select [Esc] Cancel

System Setup		
Function	Display	Basic setting
Freeze Mode Setup	Freeze Mode	: F/T (Freeze / Trigger)
Scope Switch setup	700Scope	Setup <input type="checkbox"/>
	500/600Scope	Setup <input type="checkbox"/>

Save and Exit

[] [] Move [Enter] Select [Esc] Cancel

<[Peripherals] Key>

Memory

Peripheral Setup

Memory Network Printer Storage Details

Internal Memory Compression Rate : 1/10 (.JPG)
 Free Space Warning Message : ON
 Screen Display : OFF
 Information 1 :
 Information 2 :
 Int. Mem. Usage : 2% Used 325MB Free
 Delete Backup Images Already Transferred
 Delete all copied images
 Initialize Internal Memory

External Memory Auto Copy Mode : OFF
 Usage :
 Compression Rate :
 Ext. Mem. Usage : 11% Used 3338MB Free
 Initialize External Memory

Save and Exit

[] [] Move [Enter] Select [Esc] Cancel

Network

Peripheral Setup

Memory Network Printer Storage Details

Save and Exit

[] [] Move [Enter] Select [Esc] Cancel

Printer

Peripheral Setup

Memory Network Printer Storage Details

Printer Setting Usage : Not used
 Number of Prints : 1
 Multi Print : 4in1

Save and Exit

[] [] Move [Enter] Select [Esc] Cancel

Storage

Peripheral Setup

Memory Network Printer Storage Details

Save and Exit

[] [] Move [Enter] Select [Esc] Cancel

Details

Peripheral Setup

Memory Network Printer Storage Details

Network Setup Usage : Not used
 Compression Rate : 1/20 (.JPG)

Internal Memory Storage Backup to Internal Memory : OFF
 When backed up to Internal Memory, its settings are disabled.
 Delete Backup Images Already Transferred : Not used
 Transfer Backup images Not Yet Transferred : Not used

Save and Exit

[] [] Move [Enter] Select [Esc] Cancel

<[Image] Key>

Image Setup Page

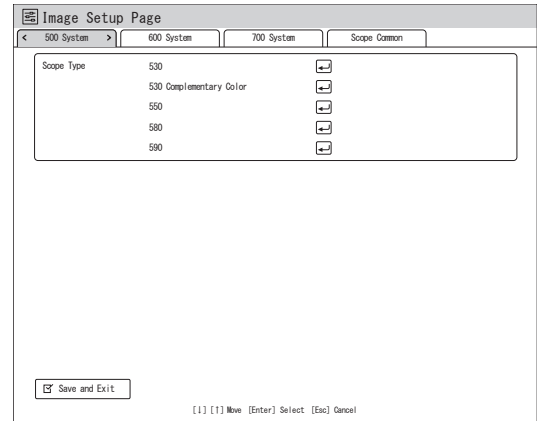
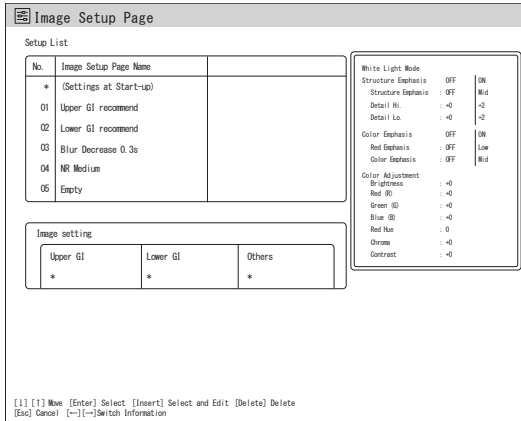

<[Panel] Key>

Panel Button Setup screen

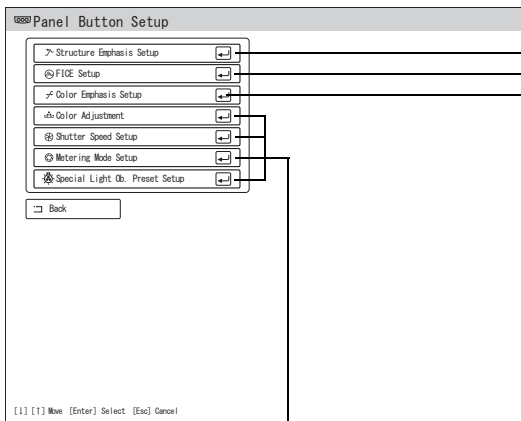

The submenu of each of these four menus is displayed on the next page.

Submenu

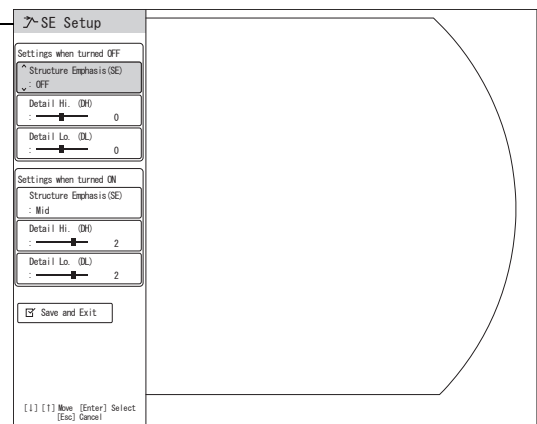

Submenu

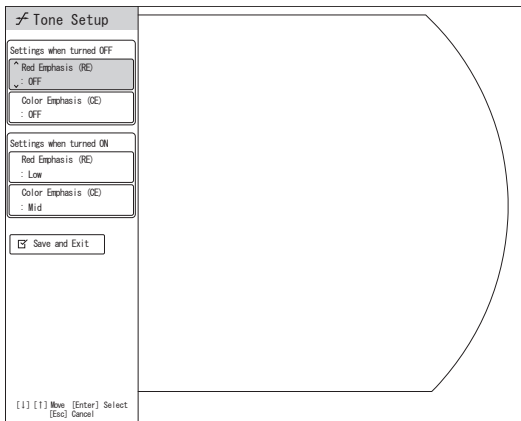

Submenu

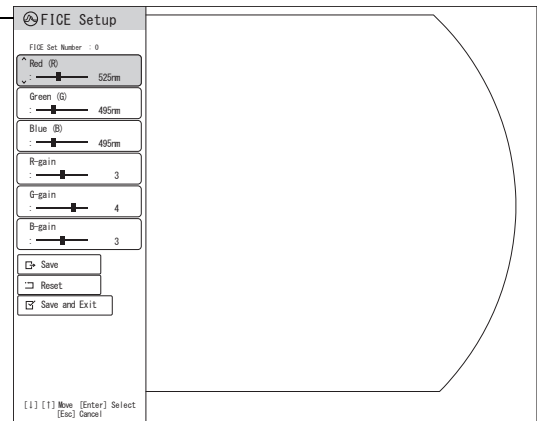

Panel Button Setup screen

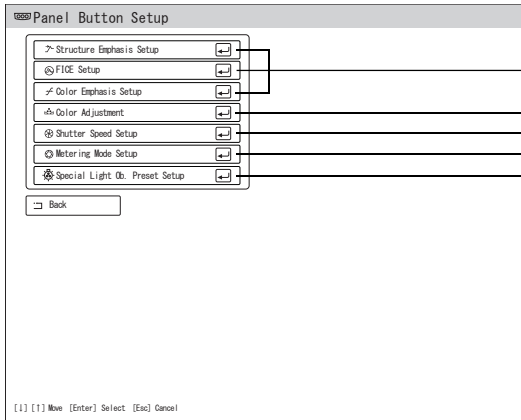

The submenu of each of these three menus is displayed on the previous page.

Submenu

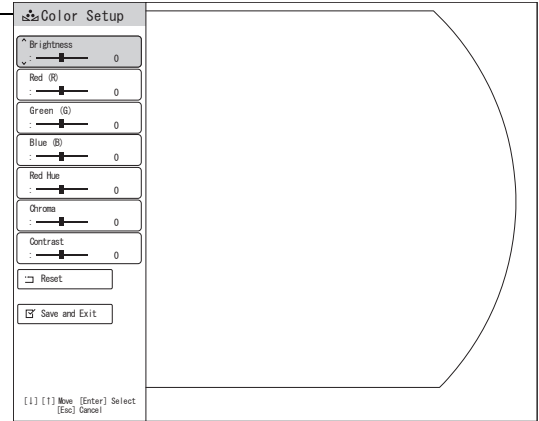

Submenu

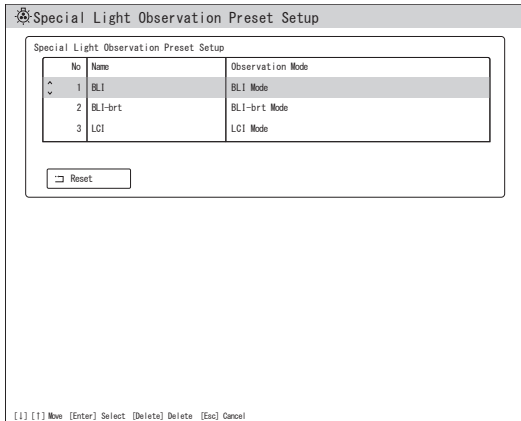

Submenu

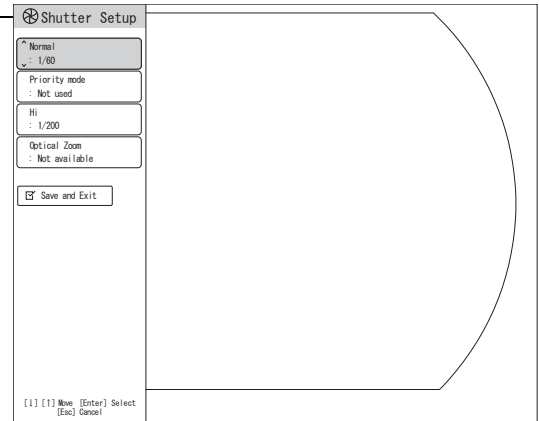

Submenu

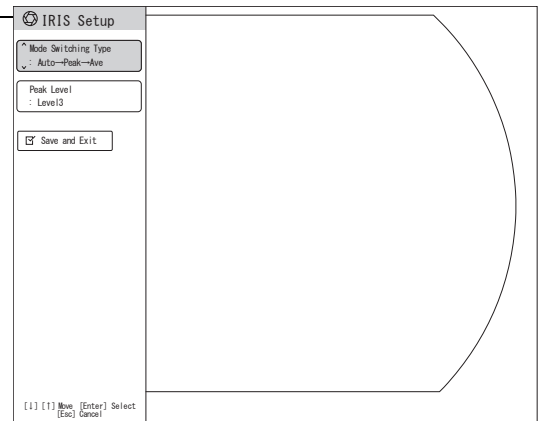

<[Search] Key>

Search screen (for setting search conditions)
When on the network

Search All

Search All

Search Cond.

Exam No. or Patient ID : _____

Date of Exam : ____ / ____ / ____

Internal Memory Images : Included

External Memory Images : Included

Bkups Not Yet Transferred to FTP : Included

Bkups Already Transferred to FTP : Included

Search

[1] [1] Move [Enter] Select [Esc] Cancel

Search screen (list)

Search All

Search Conditions : NA NA

Search Result 1/1

No.	Date of Exam	Patient ID	Patient Name	Exam No.
01	2014/11/27			
02	2014/11/27			
03	2014/11/27			

Search Result 1/1

[1] [1] Move [Enter] Select [Esc] Cancel [N] Transfer [D] Delete [A] Copy all [C] Copy

5.2 Registering and Editing Patient Information

This section describes the methods of registering and editing patient information.

Note

- During examination, the observation screen is displayed as a sub-screen at the lower right-hand side of the setting screen.

5.2.1 Registering Patient Information

This section describes the method of registering patient information.

The patient information entry screen has two modes: "Patient number auto entry" and "Fixed patient number". The mode is set by service personnel.

When "Patient number auto entry" is selected, a maximum of 45 patients can be registered in the patient list.

When "Fixed patient number" is selected, patient information is entered for each examination.

When patient information is entered by pressing the [Patient Entry] key, the patient number is fixed to "01" and old patient information is overwritten by new patient information each time patient information is entered.

<Patient Number Auto Entry>

- (1) Press the [Patient Entry] key.
The Patient Information Entry screen appears.
Patient information starts from "Patient 01."

Patient Information Entry
 Patient 01
 Exam No. :
 Patient ID :
 Patient Name :
 Sex : None Male Female
 D.o.B. : / /
 Age :
 Doctor :
 Procedure :
 Message :
 Examine This Patient
 End Registration
 Enter Next Patient Info.
 Clear All
 [] [] Move [Enter] Select [Esc] Cancel

- (2) Move the cursor to “Exam No.”.
Character entry is enabled. Enter the examination number and press the [Enter] key.
Enter the examination number, using up to 16 characters.

Note

- With regard to the items not to be registered, do not press the [Enter] key on the item but only move the cursor to the next item.

The screenshot shows the 'Patient Information Entry' form with the following fields and controls:

- Exam No. : 20150214 (Selected)
- Patient ID :
- Patient Name :
- Sex : None Male Female
- D. o. B. : / /
- Age :
- Doctor :
- Procedure :
- Message :
- Buttons: Examine This Patient, End Registration, Enter Next Patient Info., Clear All
- Footer: [1] [1] Move [Enter] Select [Esc] Cancel

- (3) Move the cursor to “Patient ID”.
Enter the patient ID and press the [Enter] key.
Enter the patient ID, using up to 16 characters.

Note

- Depending on the peripherals, the number of characters available may be less than 16. Accordingly, confirm the number of characters available for each peripheral before entering characters.

The screenshot shows the 'Patient Information Entry' form with the following fields and controls:

- Exam No. : 20150214
- Patient ID : 123456 (Selected)
- Patient Name :
- Sex : None Male Female
- D. o. B. : / /
- Age :
- Doctor :
- Procedure :
- Message :
- Buttons: Examine This Patient, End Registration, Enter Next Patient Info., Clear All
- Footer: [1] [1] Move [Enter] Select [Esc] Cancel

- (4) Move the cursor to “Patient Name”.
Enter the patient name and press the [Enter] key.
Enter the patient name, using up to 20 characters.

The screenshot shows a terminal window titled "Patient Information Entry" with a patient ID of 01. The form contains the following fields: Exam No. (20150214), Patient ID (123456), Patient Name (FUJI TAROU), Sex (None, Male, Female), D.o.B. (/ /), Age, Doctor, Procedure, and Message. The "Patient Name" field is highlighted with a cursor. Below the form are buttons for "Examine This Patient", "End Registration", "Enter Next Patient Info.", and "Clear All". A legend at the bottom indicates: [1] [1] Move [Enter] Select [Esc] Cancel.

- (5) Move the cursor to “Sex”.
By using the [←] or [→] keys, select the sex of the patient from among “None”, “Male” and “Female”.

The screenshot shows the same terminal window as above, but the "Sex" field is now highlighted with a cursor. The "Sex" field displays "None", "Male", and "Female" as options. The legend at the bottom remains the same: [1] [1] Move [Enter] Select [Esc] Cancel.

- (6) Move the cursor to “D. o. B.”.
Enter the year, month and day of birth of the patient.

Note

- Enter the Christian year.

Patient Information Entry

Patient 01

Exam No.	: 20150214
Patient ID	: 123456
Patient Name	: FUJI TAROU
Sex	: None Male Female
D.o.B.	: 1960 / 07 /
Age	:
Doctor	:
Procedure	:
Message	:

Examine This Patient

End Registration

Enter Next Patient Info.

Clear All

[1] [1] Move [Enter] Select [Esc] Cancel

- (7) When the date of birth of the patient is entered, the age of the patient is calculated and displayed automatically.
For changing the age, move the cursor to “Age” and then enter the age of the patient and press the [Enter] key.

Note

- When moving the cursor to “D. o. B.” again, the age of the patient is returned to the age that is calculated automatically.

Patient Information Entry

Patient 01

Exam No.	: 20150214
Patient ID	: 123456
Patient Name	: FUJI TAROU
Sex	: None Male Female
D.o.B.	: 1960 / 07 / 07
Age	: 54
Doctor	:
Procedure	:
Message	:

Examine This Patient

End Registration

Enter Next Patient Info.

Clear All

[1] [1] Move [Enter] Select [Esc] Cancel

- (8) Move the cursor to “Doctor” and press the [Enter] key.
The doctor names registered in the doctor list are displayed in the pop-up menu.

→ “4.2.10 Setting the Doctor's Name”

Select “None” or a doctor name.

The screenshot shows the 'Patient Information Entry' window. The 'Doctor' field is selected, and a pop-up menu is displayed with the following options: None, AOKIYAMA, and SHIMAGAMA. The 'None' option is currently selected. Below the form, there are buttons for 'Examine This Patient', 'End Registration', 'Enter Next Patient Info.', and 'Clear All'. The status bar at the bottom indicates navigation keys: [1] [1] Move [Enter] Select [Esc] Cancel.

- (9) If the doctor name is not found or it is entered manually, move the cursor to “Doctor” and press the [Insert] key.

Character entry is enabled. Enter the doctor name manually and press the [Enter] key.

When “Doctor List Auto Search” is ON, the entered doctor name is automatically searched in the doctor list. When the entered doctor name is found, the settings registered in the doctor list are applied. If the entered doctor name is not found, the confirmation message “Specified doctor not registered” appears.

Note

- “Doctor List Auto Search” is case-sensitive.
- The doctor name entered here will not be registered in the doctor list.

→ “4.2.10 Setting the Doctor's Name”

The screenshot shows the 'Patient Information Entry' window. The 'Doctor' field is active, and the cursor is positioned at the end of the field. The 'None' option is selected in the dropdown menu. Below the form, there are buttons for 'Examine This Patient', 'End Registration', 'Enter Next Patient Info.', and 'Clear All'. The status bar at the bottom indicates navigation keys: [1] [1] Move [Enter] Select [Esc] Cancel.

- (10) Move the cursor to “Procedure” and press the [Enter] key.
The procedure names registered in the procedure list are displayed in the pop-up menu.

→ “4.2.11 Setting the Procedure Name”

Select “None” or a procedure name.

If a procedure name is entered manually, move the cursor to “Procedure” and press the [Insert] key. Character entry is enabled. Enter the procedure name manually and press the [Enter] key. The entered procedure name is automatically searched in the procedure list.

When the entered procedure name is found, the procedure name registered in the procedure list is used.

If the entered procedure name is not found, the confirmation message “Specified procedure not registered” appears.

Note

- The procedure name entered here will not be registered in the procedure list.

→ “4.2.11 Setting the Procedure Name”

The screenshot shows a window titled "Patient Information Entry" with a patient ID of 01. The form contains several input fields: Exam No. (20150214), Patient ID (123456), Patient Name (FUJI TAROU), Sex (None, Male, Female), D.o.B. (1960 / 07 / 07), Age (54), and Doctor (ADYAMA). A dropdown menu for "Procedure" is open, showing options: None, Procedure 1, Procedure 2, and Procedure 3. Below the dropdown are buttons for "Examine This Patient", "End Registration", "Enter Next Patient Info.", and "Clear All". At the bottom, a status bar indicates "[] [] Move [Enter] Select [Esc] Cancel".

- (11) Move the cursor to “Message” and press the [Enter] key.
The message names registered in the message list are displayed in the pop-up menu.

→ “4.2.12 Setting the Message”

Select “None” or “Message”.

The screenshot shows a software interface titled "Patient Information Entry". At the top, it says "Patient 01". Below this are several input fields for patient data:

- Exam No. : 20150214
- Patient ID : 123456
- Patient Name : FUJI TAROU
- Sex : None Male Female
- D.o.B. : 1960 / 07 / 07
- Age : 54
- Doctor : ADYAMA
- Procedure : Procedure 1

The "Message" field is currently set to "None". A pop-up menu is open below it, showing three options: "Message 1", "Message 2", and "Message 3". Below the pop-up menu are several buttons: "Examine This Patient", "End Registratio", "Enter Next Pat", and "Clear All". At the bottom left of the window, there is a status bar with the text "[1] [1] Move [Enter] Select [Esc] Cancel".

- (12) When Steps (1) to (11) are performed, registration of data for one patient is completed. When executing examination using the registered patient information, move the cursor to “Examine This Patient” and press the [Enter] key.

Patient Information Entry

Patient 01

Exam No. : 20150214

Patient ID : 123456

Patient Name : FUJI TAROU

Sex : None Male Female

D.o.B. : 1960 / 07 / 07

Age : 54

Doctor : ADYAMA

Procedure : Procedure 1

Message : Message 1

Examine This Patient

End Registration

Enter Next Patient Info.

Clear All

[1] [1] Move [Enter] Select [Esc] Cancel

The confirmation dialog regarding the specified patient information and scope information appears.

The confirmation dialog disappears when the [Enter] key is pressed.

2018/07/08 06:21:11AM 002:06

ID 123456

Name FUJI TAROU

Message None

Sex None Doctor None

D. o. B. ---/--/-- Procedure None

Age --- Number of recordable images in Internal Memory : 20856

Scope Type : EG-740TM Forceps : 3.2

Scope Serial : AC732G004 Distal : 9.8

Scope ID : 2 Flexible : 10.7

3.2

Procedure01

FUJI TAROU 1234567890123456 M 64 1960/07/01 R 540mm G 480mm B 420mm Rgan:1 Cgan:5 Bgan:5 D

Note

- To capture the screen, press the “Freeze” switch. The image data of the screen is saved to the internal storage device or FTP server on the network.
- “5.4.2 Memory Tab”
- “5.4.4 Details Tab”

- (13) To register the next patient data, move the cursor to “Enter Next Patient Info.” and press the [Enter] key.
 Now the system is ready for the next patient data “Patient 02” to be entered.

Patient Information Entry
 Patient 01

Exam No.	: 20150214
Patient ID	: 123456
Patient Name	: FUJI TAROU
Sex	: None Male Female
D.o.B.	: 1960 / 07 / 07
Age	: 54
Doctor	: ADYAMA
Procedure	: Procedure 1
Message	: Message 1

Examine This Patient
 End Registration
 Enter Next Patient Info.
 Clear All

[1] [1] Move [Enter] Select [Esc] Cancel

- (14) Repeat steps (2) to (11) to enter patient information.

Patient Information Entry
 Patient 01

Exam No.	: 20150214
Patient ID	: 123456
Patient Name	: FUJI TAROU
Sex	: None Male Female
D.o.B.	: 1960 / 07 /
Age	:
Doctor	:
Procedure	:
Message	:

Examine This Patient
 End Registration
 Enter Next Patient Info.
 Clear All

[1] [1] Move [Enter] Select [Esc] Cancel

- (15) After entering all patient information, move the cursor to “End Registration” and press the [Enter] key.
 The display returns to the observation screen.

Patient Information Entry
 Patient 01

Exam No.	: 20150214
Patient ID	: 123456
Patient Name	: FUJI TAROU
Sex	: None Male Female
D.o.B.	: 1960 / 07 / 07
Age	: 54
Doctor	: ADYAMA
Procedure	: Procedure 1
Message	: Message 1

Examine This Patient
 End Registration
 Enter Next Patient Info.
 Clear All

[1] [1] Move [Enter] Select [Esc] Cancel

<Fixed Patient Number>

- Press the [Patient Entry] key.
The Patient Information Entry screen appears.
Patient information is fixed to "Patient 01".

The screenshot shows the 'Patient Information Entry' screen. At the top, it displays 'Patient 01' and a 'Clear All' button. Below this is a form with the following fields:

Exam No.	20150214
Patient ID	123456
Patient Name	FUJI TAROU
Sex	None Male Female
D. o. B.	1960 / 07 / 07
Age	54
Doctor	ADYAMA
Procedure	Procedure 1
Message	Message 1

At the bottom of the form is an 'Examine This Patient' button. At the very bottom of the screen, there is a footer: '[] [1] Move [Enter] Select [Esc] Cancel'.

- To clear all entries (for example, if any patient data has already been entered), move the cursor to "Clear All" and press the [Enter] key.
The confirmation message "Patient information will be cleared. OK?" appears. When "Yes" is selected, all displayed entries are cleared.

This screenshot is identical to the previous one, but with a confirmation dialog box overlaid on the form. The dialog box contains the text: 'Patient information will be cleared. OK?' and has 'No' and 'Yes' buttons. The 'Yes' button is highlighted, indicating it has been selected.

- (3) Move the cursor to “Exam No.”.
Character entry is enabled. Enter the examination number and press the [Enter] key.
Enter the examination number, using up to 16 characters.

Note

- With regard to the items not to be registered, do not press the [Enter] key on the item but only move the cursor to the next item.

Patient Information Entry
 Patient 01
 Exam No. : |
 Patient ID :
 Patient Name :
 Sex : None Male Female
 D.o.B. : / /
 Age :
 Doctor :
 Procedure :
 Message :

[↑] [↓] Move [Enter] Select [Esc] Cancel

- (4) Enter each item of patient information referring to Steps (3) to (11) in “<Patient Number Auto Entry>”.
- (5) When all items are entered, move the cursor to “Examine This Patient” and press the [Enter] key.

Note

- When “Patient ID” is selected for “Exam. Data” in “Displayed Info.” in the System Setup screen, “Patient ID” is selected immediately after opening the Patient Information Entry screen. To enter the examination number, select “Exam No.” by using the [↑] and [↓] keys.

Patient Information Entry
 Patient 01
 Exam No. : 20150214
 Patient ID : 123456
 Patient Name : FUJI TAROU
 Sex : None Male Female
 D.o.B. : 1960 / 07 / 07
 Age : 54
 Doctor : ADYAMA
 Procedure : Procedure 1
 Message : Message 1

[↑] [↓] Move [Enter] Select [Esc] Cancel

The confirmation dialog regarding the specified patient information and scope information appears.

The confirmation dialog disappears when the [Enter] key is pressed.

Note

- To capture the screen, press the “Freeze” switch. The image data of the screen is saved to the internal storage device or FTP server on the network.

➔ “5.4.2 Memory Tab”

➔ “5.4.4 Details Tab”

5.2.2 Calling Up Patient Information

This section explains how to call up patient information.

- (1) Press the [Patient] key.

The Patient List screen appears.

To turn the pages, move the cursor to “Patient List 1/3 (to 3/3)” and press the [←] or [→] keys.

No.	Name	ID
01	FUJI TAROU	123456
02	TANAKA ICHIROU	123457
03	SUZUKI KENICHI	123458
04		
05		
06		
07		
08		
09		
10		
11		
12		
13		
14		
15		

- (2) When the cursor is moved to a patient number, detailed information on the selected patient is displayed at the right-hand side of the screen.

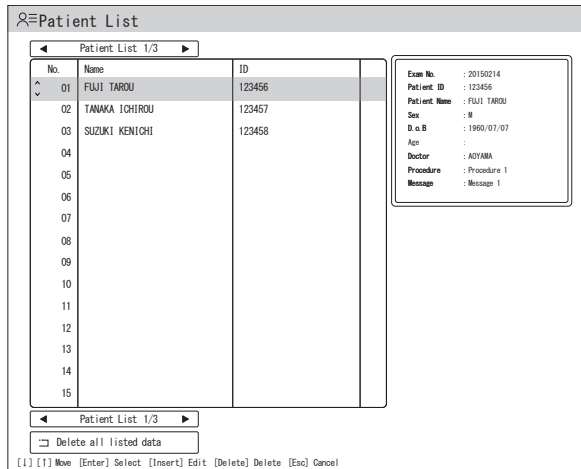

When the [Enter] key is pressed, the selected patient information is called up and operation returns to the observation screen.

The confirmation dialog indicating the selected patient information and scope information is displayed. The confirmation dialog disappears when the [Enter] key is pressed.

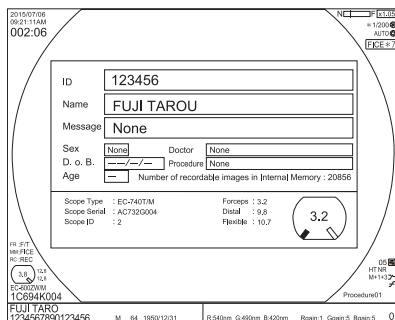

Note

- To capture the screen, press the “Freeze” switch. The image data of the screen is saved to the internal storage device or FTP server on the network.

➔ “5.4.2 Memory Tab”

➔ “5.4.4 Details Tab”

5.2.3 Amending Patient Information

This section describes the method of amending patient information.

- (1) Press the [Patient] key.

The Patient List screen appears.

To turn the pages, move the cursor to “Patient List 1/3 (to 3/3)” and press the [←] or [→] keys.

Note

- For information on the patient whose examination is already finished, (☑) is displayed next to the patient number.

→ “7.19 Finishing the Examination”

The screenshot shows the 'Patient List' screen with a table of patients and a detailed information panel on the right. The table has columns for No., Name, and ID. The detailed panel shows fields for Exam No., Patient ID, Patient Name, Sex, D.o.B, Age, Doctor, Procedure, and Message.

No.	Name	ID
01	FUJII TAROU	123456
02	TANAKA ICHIROU	123457
03	SUZUKI KENICHI	123458
04		
05		
06		
07		
08		
09		
10		
11		
12		
13		
14		
15		

Exam No. :
Patient ID :
Patient Name :
Sex :
D.o.B :
Age :
Doctor :
Procedure :
Message :

- (2) When moving the cursor to the desired patient number, detailed information on the selected patient is displayed at the right-hand side of the screen.

When the [Insert] key is pressed, the Patient Information Entry screen appears.

Note

- When the [Enter] key is pressed, the selected patient information is called up and operation returns to the observation screen.

The screenshot shows the 'Patient List' screen with a list of patients. Patient 01 is selected, and the detailed information panel on the right is updated with patient-specific data. The table has columns for No., Name, and ID. The detailed panel shows fields for Exam No., Patient ID, Patient Name, Sex, D.o.B, Age, Doctor, Procedure, and Message.

No.	Name	ID
01	FUJII TAROU	123456
02	TANAKA ICHIROU	123457
03	SUZUKI KENICHI	123458
04		
05		
06		
07		
08		
09		
10		
11		
12		
13		
14		
15		

Exam No. : 20150214
Patient ID : 123456
Patient Name : FUJII TAROU
Sex : M
D.o.B : 1960/07/07
Age :
Doctor : AOTABA
Procedure : Procedure 1
Message : Message 1

- (3) On the Patient Information Entry screen, make corrections to patient information. For information on how to correct patient information, refer to the following section.

→ “5.2.1 Registering Patient Information”

The screenshot shows the 'Patient Information Entry' screen with the following data:

Exam No.	: 20150214
Patient ID	: 123456
Patient Name	: FUJI TAROU
Sex	: None Male Female
D. o. B.	: 1960 / 07 / 07
Age	: 54
Doctor	: None
Procedure	: AOKAMA
Message	: SHIBUYA

Below the form are two buttons: 'End Registration' and 'Clear All'. A keyboard legend at the bottom indicates: [] [] Move [Enter] Select [Esc] Cancel.

Note

- To delete all entries, move the cursor to “Clear All” and press the [Enter] key. The confirmation message “Patient information will be cleared. OK?” appears. When “Yes” is selected, all the contents of the displayed patient information are deleted.
- To delete patient information, refer to the following section.

→ “5.2.4 Deleting Patient Information”

- (4) When correction of patient information is completed, move the cursor to “End Registration” and press the [Enter] key. Operation returns to the Patient List screen.

The screenshot shows the 'Patient Information Entry' screen with the following data:

Exam No.	: 20150214
Patient ID	: 123456
Patient Name	: FUJI TAROU
Sex	: None Male Female
D. o. B.	: 1960 / 07 / 07
Age	: 54
Doctor	: SHIBUYA
Procedure	: Procedure 1
Message	: Message 1

Below the form are two buttons: 'End Registration' and 'Clear All'. A keyboard legend at the bottom indicates: [] [] Move [Enter] Select [Esc] Cancel.

- (5) On the Patient List screen, press the [Enter] key.
 Corrected patient information is registered and operation returns to the observation screen. The confirmation dialog indicating the selected patient information and scope information is displayed. The confirmation dialog disappears when the [Enter] key is pressed.

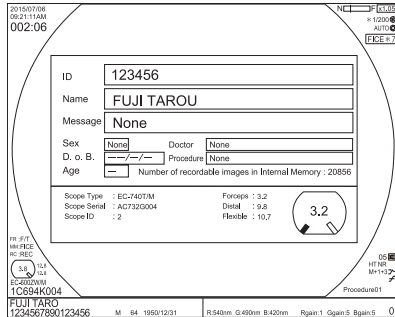

Note

- To capture the screen, press the “Freeze” switch. The image data of the screen is saved to the internal storage device or FTP server on the network.
- ➔ “5.4.2 Memory Tab”
- ➔ “5.4.4 Details Tab”

5.2.4 Deleting Patient Information

This section describes the method of deleting registered patient information.

- (1) Press the [Patient] key.

The Patient List screen appears. To turn the pages, move the cursor to “Patient List 1/3 (to 3/3)” and press the [←] or [→] keys.

The screenshot shows the 'Patient List' screen with a table of patients and a detailed view on the right. The table has columns for No., Name, and ID. The detailed view shows fields for Exam No., Patient ID, Patient Name, Sex, D.o.B., Age, Doctor, Procedure, and Message.

No.	Name	ID
01	FUJII TAROU	123456
02	TANAKA ICHIROU	123457
03	SUZUKI KENICHI	123458
04		
05		
06		
07		
08		
09		
10		
11		
12		
13		
14		
15		

Exam No. :
Patient ID :
Patient Name :
Sex :
D.o.B :
Age :
Doctor :
Procedure :
Message :

- (2) When moving the cursor to the desired patient number, detailed information on the selected patient is displayed at the right-hand side of the screen.

Note

- When the [Enter] key is pressed, the selected patient information is called up and operation returns to the observation screen.

The screenshot shows the 'Patient List' screen with patient 01 selected. The detailed view on the right shows fields for Exam No., Patient ID, Patient Name, Sex, D.o.B., Age, Doctor, Procedure, and Message.

No.	Name	ID
01	FUJII TAROU	123456
02	TANAKA ICHIROU	123457
03	SUZUKI KENICHI	123458
04		
05		
06		
07		
08		
09		
10		
11		
12		
13		
14		
15		

Exam No. : 20150214
Patient ID : 123456
Patient Name : FUJII TAROU
Sex : M
D.o.B : 1960/07/07
Age :
Doctor : AOTYAMA
Procedure : Procedure 1
Message : Message 1

- (3) Move the cursor to patient information to be deleted and press the [Delete] key.
The confirmation message “This patient information will be deleted. OK?” appears.

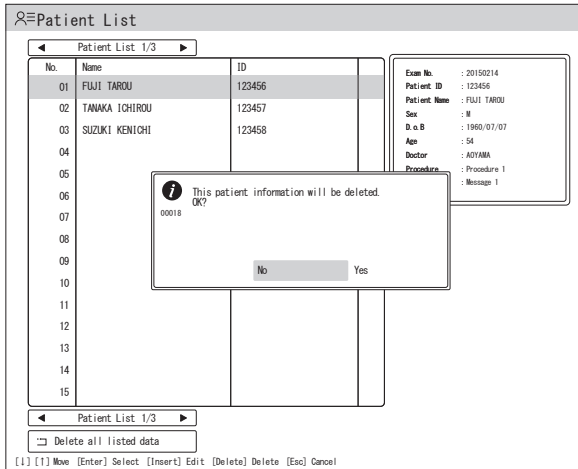

When “Yes” is selected, the selected patient information is deleted.

When “No” is selected, the settings are not changed and operation returns to the screen in Step (1).

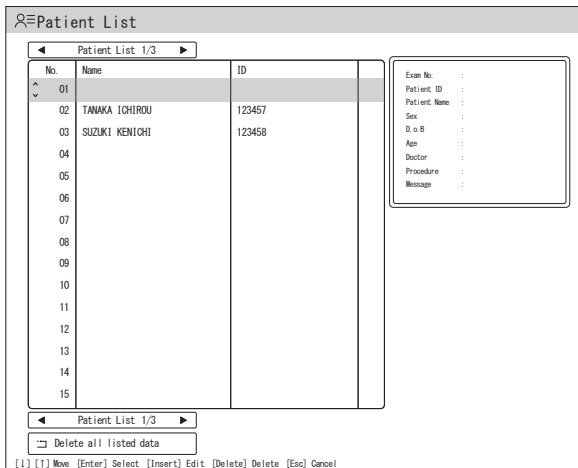

Note

- When deleting all patient information, move the cursor to “Delete all listed data” and press the [Enter] key.

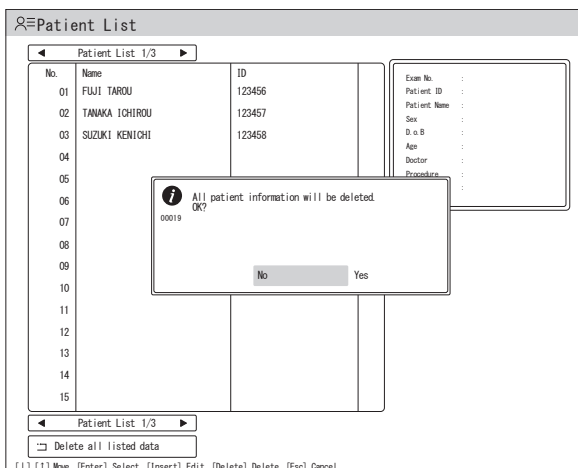

- (4) Press the [Esc] key.
Operation returns to the observation screen.

5.3 Setting the Panel Buttons (Image Processing Functions)

This chapter explains how to set the panel buttons (image processing functions).

Note

- During examination, the observation screen is displayed as a sub-screen at the lower right-hand side of the setting screen.

5.3.1 Basic Setup Operations

- (1) Press the [Panel] key on the keyboard. The Panel Button Setup screen appears.

Note

- Essentially the same operation applies to other setup keys.
- During the observation, the observation screen is displayed in the sub-screen at the lower right side of the setup screen.

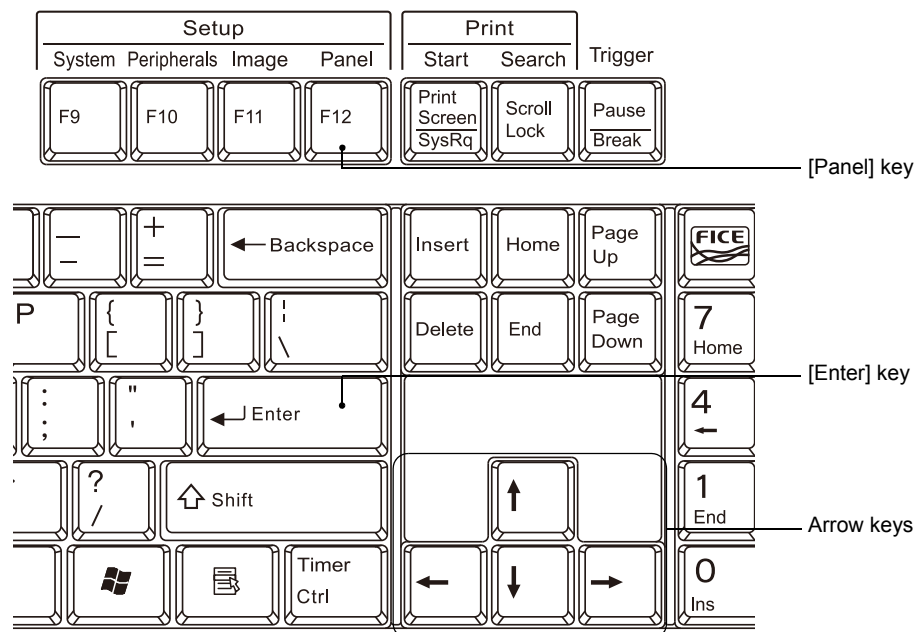

- (2) On the setup screen, use the [↑] and [↓] keys to select an item. For the items with a “↓” mark at the right end, a submenu is displayed when the [Enter] key is pressed.

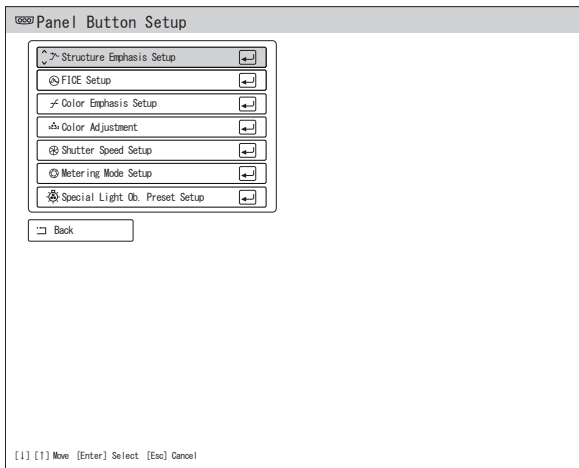

- (3) To change the setting of an item, select the item using the [↑] and [↓] keys and press the [Enter] key.

Note

- In some cases, the setting can be changed by using the the [←] and [→] keys.
- For the items with a “↔” mark at the right end, a submenu is displayed.

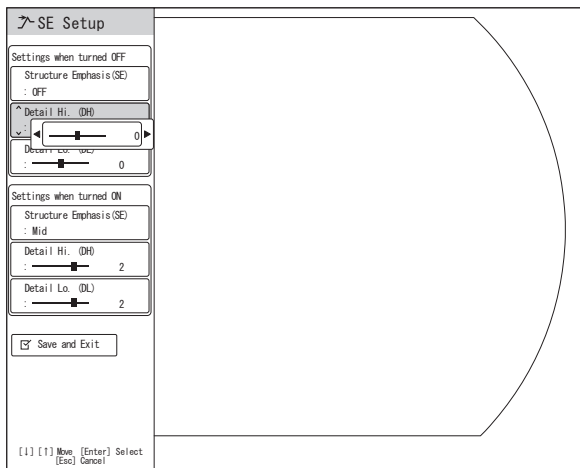

- (4) When the [Enter] key is pressed after changing the setting by using the [↑], [↓], [←] and [→] keys, the cursor moves to the next item.

Note

- In some cases, the cursor can be moved to the previous or next item by using the [↑] and [↓] keys without pressing the [Enter] key.

- (5) To save the settings, move the cursor to “Save and Exit” and press the [Enter] key.

Note

- Be sure to select “Save and Exit” when a setting is changed. Otherwise, the changed value is not saved.
- When the [Esc] key is pressed, the settings are canceled and operation returns to the observation screen.

- The photometry mode settings screen can be displayed by pressing and holding the button on the front panel for two seconds instead of performing Steps (1) and (2).

5.3.2 Structure Emphasis Settings

This section explains how to set the structure emphasis function.

The structure emphasis function enables you to adjust the sharpness of the subject structure and obtain a clearer image for closer observation of the details.

Higher levels may result in more noise in the image. Accordingly, adjust the level while viewing the image.

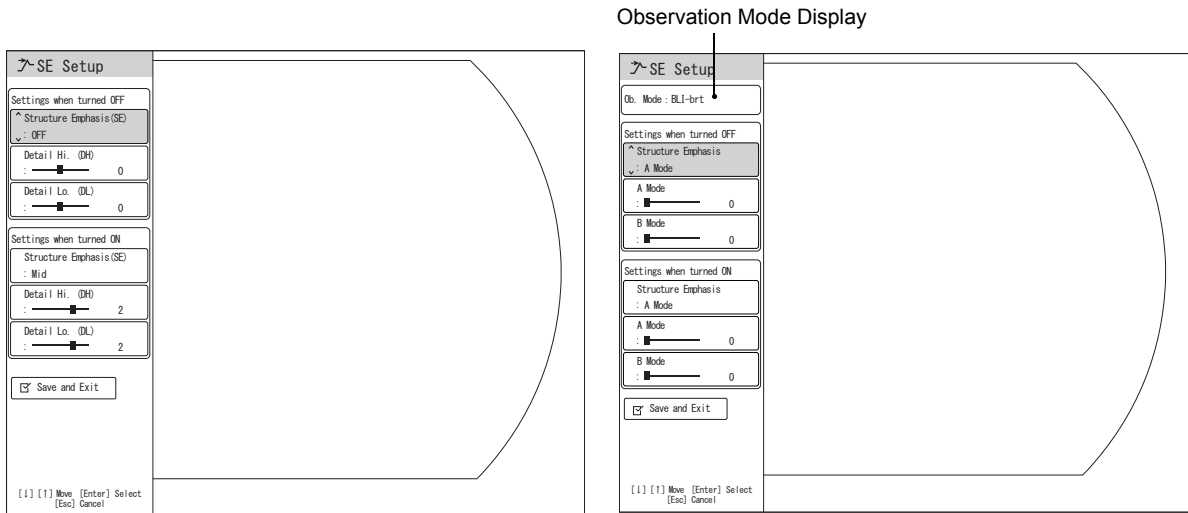

<In the case of Normal mode>

Category	Item	Value	Description
Settings when turned OFF Settings when turned ON	Structure Emphasis (SE)	OFF	Select the level of structure emphasis. When OFF is selected, structure emphasis is not applied.
		Low	
		Mid	
		Hi	
	Detail Hi. (DH)	-4 to +4	Adjust the sharpness of the details of the image. When “-4” is selected, contour emphasis is not applied.
	Detail Lo. (DL)	-4 to +4	Adjust the sharpness of the entire part of the image. When “-4” is selected, contour emphasis is not applied.

Remarks

- The setting that is applied when the structure emphasis function is set to OFF and the setting that is applied when the structure emphasis function is set to ON can be specified respectively.
- Higher levels may result in more noise in the image. Accordingly, adjust the level while viewing the image.

<In the case of BLI, BLI-bright or LCI>

To set the structure emphasis for the special light observation mode, it is necessary to set the observation mode to “BLI”, “BLI-bright” or “LCI” in advance.

Note

- The settings of the structure emphasis can be retained for each observation mode. When the SE Setup screen is displayed while in the BLI mode, the structure emphasis settings for the BLI mode are specified. When it is displayed while in the BLI-bright mode, the structure emphasis settings for the BLI-bright mode are specified. When it is displayed while in the LCI mode, the structure emphasis settings for the LCI mode are specified.

Category	Item	Value	Description
Settings when turned OFF	Structure Emphasis	A Mode	Select the structure emphasis mode to be used.
		B Mode	
Settings when turned ON	A Mode	0 to 8	When “0” is set, structure emphasis is not applied.
	B Mode	0 to 8	When “0” is set, structure emphasis is not applied.
Remarks			
<ul style="list-style-type: none"> • The setting that is applied when the structure emphasis function is set to OFF and the setting that is applied when the structure emphasis function is set to ON can be specified respectively. • Higher levels may result in more noise in the image. Accordingly, adjust the level while viewing the image. 			

Note

- For the operations on the menu screen, refer to the description of basic setup operations.
→ “5.3.1 Basic Setup Operations”
- How to use
→ “7.11 Turning On/Off Structure Emphasis”

5.3.3 Setting FICE

This section explains how to set FICE.

FICE is a spectral image processing function.

FICE extracts spectral images of specific wavelength components from the original image by image processing, assigns each component to R, G and B and displays the pseudocolor image. FICE can enhance color tone to improve visibility of the selected structure and areas of the subject.

<Calling Up a FICE Set>

A maximum of 10 FICE sets can be memorized. Specify the number of the FICE set to be changed.

Press the [FICE] key on the keyboard. enter the number of the FICE set to be changed (among 0 to 9) using the numeric key. Select “FICE Setup” in the Panel Button Setup screen.

Note

- In the BLI, BLI-bright or LCI mode, FICE is not available.

Specified FICE Set Number

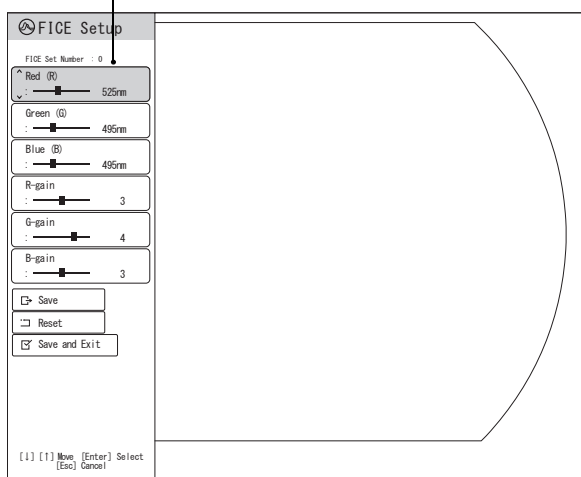

Category	Item	Value	Description
FICE Set Number (0 to 9)	Red (R)	400nm to 695nm	The wavelength can be set in 5nm increments. When changing the wavelength, you cannot assign the same wavelength to all of the gains : R, G and B.
	Green (G)	400nm to 695nm	
	Blue (B)	400nm to 695nm	
	R-gain	1 to 5	Set the gain levels while checking the tone in the screen. When a high gain level is set, halation may occur around the high-brightness portions of the image.
	G-gain	1 to 5	
	B-gain	1 to 5	
	Save		Select this button to save the settings.
Reset		The settings for the currently selected FICE set number are reset to the factory defaults.	
Remarks			
<ul style="list-style-type: none"> • When the wavelength is set to 650nm or longer, there may be little effect on the displayed image. • Halation means white blurring around a very bright area. 			

Note

- For the operations on the menu screen, refer to the description of basic setup operations.
→ “5.3.1 Basic Setup Operations”
- How to use
→ “7.12 Turning On/Off FICE”

<Confirming FICE Settings>

The number of the FICE set currently in use and the set values can be displayed.

- “3.10 Displaying FICE Set”

5.3.4 Tone Settings

This section explains how to set the tone function.

This function emphasizes the slight differences between colors in the image by increasing color saturation, allowing closer observation of the minor color tone difference within the subject.

The red emphasis function emphasizes slight differences of the reddish portions such as mucous membrane and blood vessels.

Note

- When FICE is turned “ON”, the tone function is not available.

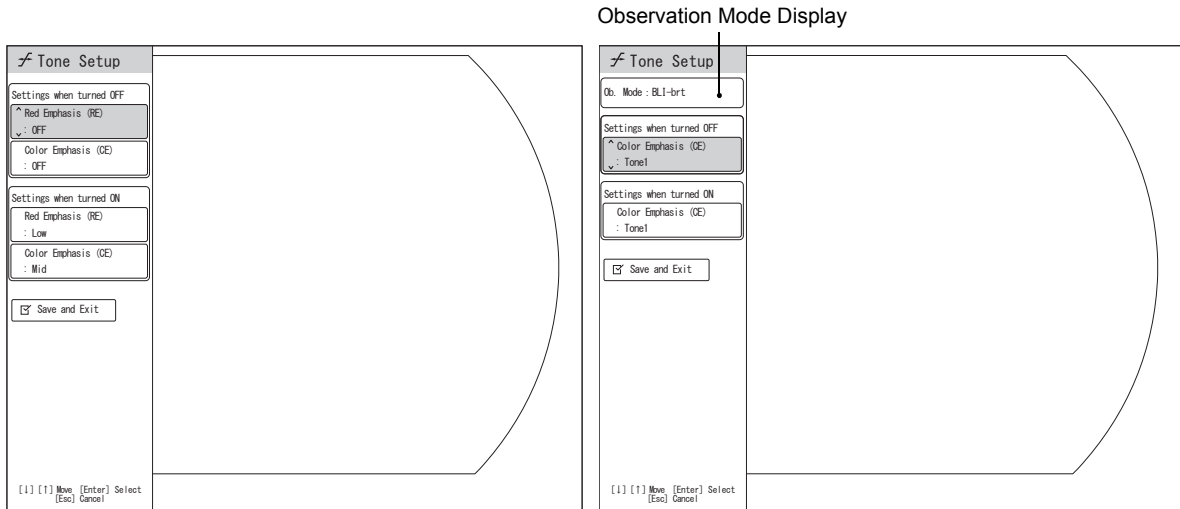

<In the case of Normal mode>

Category	Item	Value	Description
Settings when turned OFF Settings when turned ON	Red Emphasis (RE)	OFF	Select the level of red emphasis. When OFF is selected, red emphasis is not applied.
		Low	
		Mid	
		Hi	
	Color Emphasis (CE)	OFF	Select the level of color emphasis. When OFF is selected, color emphasis is not applied.
		Low	
		Mid	
Hi			
Remarks			
<ul style="list-style-type: none"> • The setting that is applied when the tone function is set to OFF and the setting that is applied when the tone function is set to ON can be specified respectively. 			

<In the case of BLI, BLI-bright or LCI>

To set the tone for the special light observation mode, it is necessary to set the observation mode to “BLI”, “BLI-bright” or “LCI” in advance.

Note

- The tone settings can be retained for each observation mode. When the Tone Setup screen is displayed while in the BLI mode, the tone settings for the BLI mode are specified. When it is displayed while in the BLI-bright mode, the tone settings for the BLI-bright mode are specified. When it is displayed while in the LCI mode, the tone settings for the LCI mode are specified.

Category	Item	Value	Description
Settings when turned OFF Settings when turned ON	Color Emphasis (CE)	OFF	Select the level of color emphasis. When OFF is selected, color emphasis is not applied. OFF can be selected only when the BLI-bright mode is selected.
		Tone 1	
		Tone 2	
		Tone 3	
Remarks			
<ul style="list-style-type: none">• The setting that is applied when the tone function is set to OFF and the setting that is applied when the tone function is set to ON can be specified respectively.			

Note

- For the operations on the menu screen, refer to the description of basic setup operations.
➔ “5.3.1 Basic Setup Operations”
- How to use
➔ “7.13 Turning On/Off the Tone”

5.3.5 Color Adjustment Settings

This section explains how to set the color adjustment function.

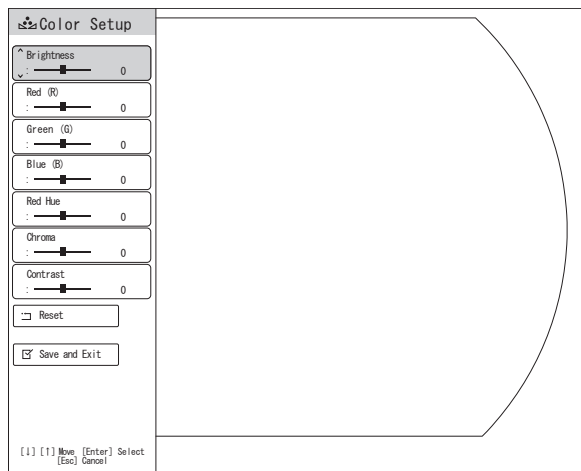

To set the color adjustment function for the special light observation mode, it is necessary to set the observation mode to “BLI” or “BLI-bright” in advance. Note that when FICE is turned “ON” or while in the LCI mode, color adjustment is disabled.

Note

- The color adjustment settings can be retained for each observation mode. When color adjustment is performed while in the BLI mode, the color settings for the BLI mode are specified. When it is performed while in the BLI-bright mode, the color settings for the BLI-bright mode are specified.

Category	Value	Description
Brightness	-4 to +4	The value can be selected from among nine levels. "+4" is the brightest setting. The factory default is "0". When a high brightness level is set, halation may occur around the high-brightness portions of the image.
Red (R)	-4 to +4	The value can be selected from among nine levels. When the level is increased, the rate of the "red" component in the entire tone increases. The factory default is "0".
Green (G)	-4 to +4	The value can be selected from among nine levels. When the level is increased, the rate of the "green" component in the entire tone increases. The factory default is "0".
Blue (B)	-4 to +4	The value can be selected from among nine levels. When the level is increased, the rate of the "blue" component in the entire tone increases. The factory default is "0".
Red Hue	M4 to Y4	The value can be selected from among nine levels. If the M value increases, the image becomes reddish. If the Y value increases, the image becomes yellowish. The factory default is "0". When the observation mode is BLI or BLI-bright, "Red Hue" cannot be changed.
Chroma	-4 to +4	The value can be selected from among nine levels. When the level is increased, the chroma increases. The factory default is "0".
Contrast	-1 to +1	The value can be selected from among three levels. When the level is increased, the contrast increases. The factory default is "0".
Reset		The color adjustment values are reset to the factory defaults.
Remarks		
<ul style="list-style-type: none"> When "Reset" is selected, the color adjustment values for the connected system scope are reset to the factory defaults. 		

Note

- For the operations on the menu screen, refer to the description of basic setup operations.
→ "5.3.1 Basic Setup Operations"

5.3.6 Setting the Shutter Speed

This section explains how to set the shutter speed.

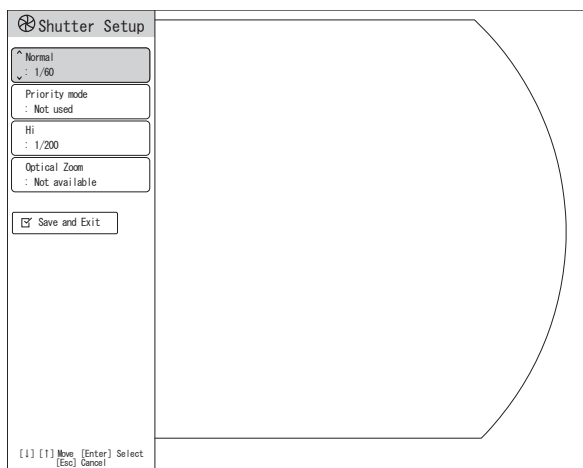

Category	Value	Description
Normal	1/60 1/100 1/200	Select the standard shutter speed at the time of turning on the power. Selectable values vary depending on the connected endoscope.
Priority mode	Not used Used (Speed 1) Used (Speed 2) Used (Speed 3)	When the priority mode is used, the shutter speed is automatically adjusted only in the following cases. <ul style="list-style-type: none"> • When the shutter speed is set to “Normal” • When the shutter speed is set to “Hi” (only if “1/100” is set for “Hi”)
Remarks <ul style="list-style-type: none"> • When the priority mode is active, the shutter speed is displayed with an asterisk, such as “ * 1/200 ⊕ ”, in the observation screen. 		
Hi	1/100 1/200 1/400 1/600 1/800	Select the shutter speed that is applied when the shutter speed is set to “Hi”. Selectable values vary depending on the connected endoscope.
Remarks <ul style="list-style-type: none"> • “Hi” is disabled when the connected endoscope supports optical zooming. 		
Optical Zoom	1/100 1/200 1/400 1/600 1/800	Choose the shutter speed when an endoscope that supports optical zoom is connected and the shutter speed setting is “Hi”. The setting value depends on the endoscope that is connected.
Remarks <ul style="list-style-type: none"> • When an endoscope that does not support optical zoom has been connected, “Optical Zoom” cannot be configured. 		

Note

- The priority mode is valid only when the following versions of system scopes are used.

Scope type	Version
530 Series (honeycomb)	Ver.2.03 or later
580 Series	All versions
600 System	All versions
700 System	All versions

Note

- For the operations on the menu screen, refer to the description of basic setup operations.
 - ➔ “5.3.1 Basic Setup Operations”
- How to use
 - ➔ “7.14 Switching the Shutter Speed”

5.3.7 Setting the Iris Mode

This section explains how to set the iris mode.

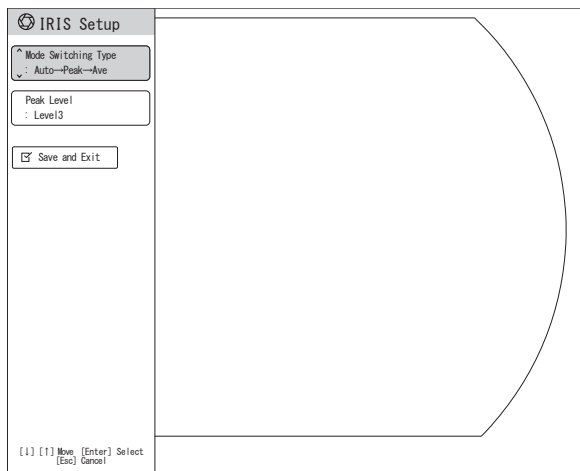

Category	Value	Description
Mode Switching Type	AUTO→PEAK→AVE AUTO→PEAK PEAK→AVE AVE→AUTO	Each the Iris Mode Button is pressed on the front panel, the iris mode switches in the order specified here.
Peak Level	Levels 1 to 5	The peak detection level specifies how much halation is decreased.
Remarks		
<ul style="list-style-type: none"> • Halation means white blurring around a very bright area. 		

Note

- For the operations on the menu screen, refer to the description of basic setup operations.
→ “5.3.1 Basic Setup Operations”
- How to use
→ “7.15 Switching the Iris Mode”

5.3.8 Special Light Observation Preset Setup

This section explains how to set the special light observation preset.

Assign the Observation modes to be switched by the illumination mode button, scope switch, or foot switch.

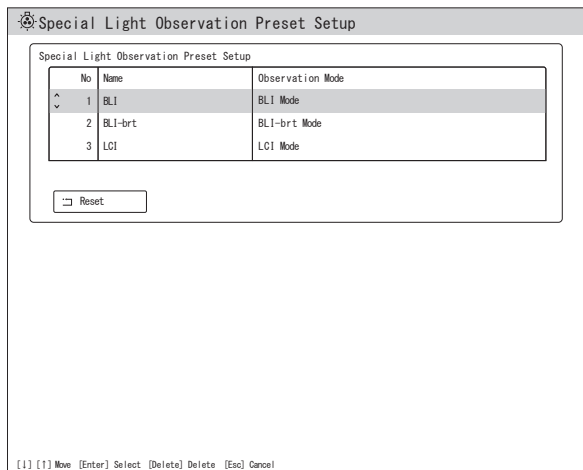

Note

- The settings screen for special-light observation presets can be displayed by pressing and holding the Illumination mode button for about two seconds.

Category	Item	Value	Description
Special Light Observation Preset Setup No.1 to No.3	Name	To be entered by using the keyboard	Select the preset number and press the [Enter] key. When the confirmation message appears, select "Registration" and press the [Enter] key to enter the preset name. Note <ul style="list-style-type: none"> Enter the preset name within 7 characters. The name already used cannot be entered, and this field cannot be blank.
	Observation Mode	BLI Mode BLI-brt Mode LCI Mode	Select the special light observation mode to be registered for the selected preset number.
	Reset		Select "Reset" and press the [Enter] key. When the confirmation message appears, select "Yes" to reset all the settings of special light observation preset to factory defaults. Note <ul style="list-style-type: none"> When resetting is performed during an examination in the special light observation mode, the screen returns to the normal mode.
Delete			Select the number of the preset to be deleted and press the [Enter] key. When the confirmation message appears, select "Yes" to delete the selected special light observation preset. Note <ul style="list-style-type: none"> When deletion is performed during an examination in the special light observation mode, the screen returns to the normal mode.

Note

- For the operations on the menu screen, refer to the description of basic setup operations.
→ "5.3.1 Basic Setup Operations"
- How to use
→ "7.10 Switching Observation Mode"

5.4 Peripheral Settings

5.4.1 Basic Setup Operations

(1) Press the [Peripherals] key. The Peripheral Setup screen appears.

Note

- Essentially the same operation applies to other setup keys.
- During the observation, the observation screen is displayed in the sub-screen at the lower right side of the setup screen.

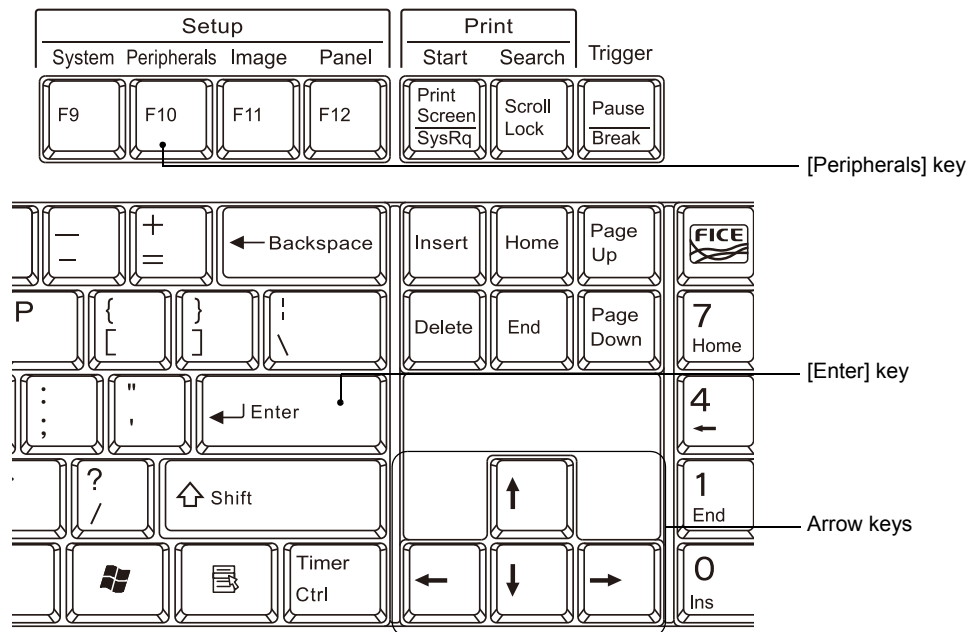

(2) On the setup screen, use the [↑] and [↓] keys to select an item.

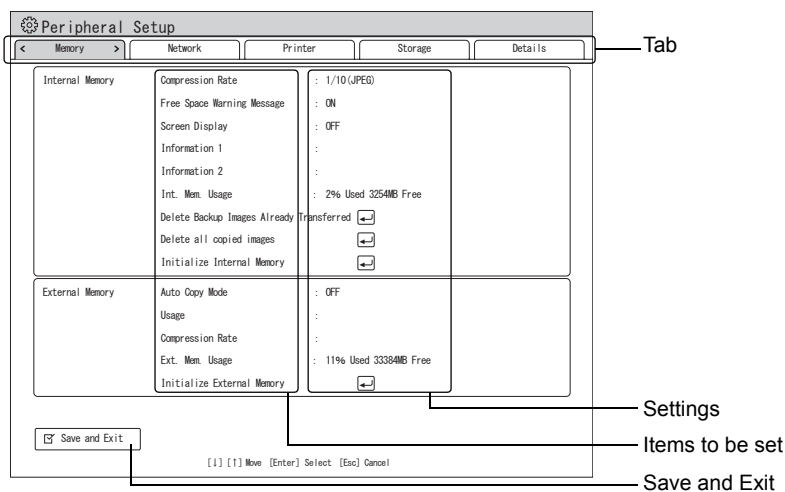

- (3) When a tab is selected, the category can be switched by using the [←] and [→] keys.

Note

- When a list has multiple pages, use the [←] and [→] keys to toggle between pages.

- (4) To change the setting of an item, select the item using the [↑] and [↓] keys and press the [Enter] key.

Note

- Use the [↑] and [↓] keys to select a value.
- For the items with a “↵” mark at the right end, a submenu is displayed.
- When “[Insert] Edit” is displayed at the bottom of the menu screen, if the [Insert] key is pressed, the desired value can be entered directly by using the keyboard.

- (5) After a value is changed, press the [Enter] key to move the cursor to the next item.

Note

- When a value is entered directly by using the keyboard, the cursor may automatically move to the next item after the input is completed.

- (6) To save the settings, move the cursor to “Save and Exit” and press the [Enter] key.

Note

- Be sure to select “Save and Exit” when a setting is changed. Otherwise, the changed value is not saved.

5.4.2 Memory Tab

This product is equipped with an internal storage device used for recording images and backing up study images during network transfer. Images in the internal storage device can be copied to an external storage device.

This section explains the settings regarding the internal and external storage devices, how to initialize them and how to delete images.

For details on the number of recordable images and how to use recorded images, see “Chapter 8 Image Recording”.

→ “Chapter 8 Image Recording”

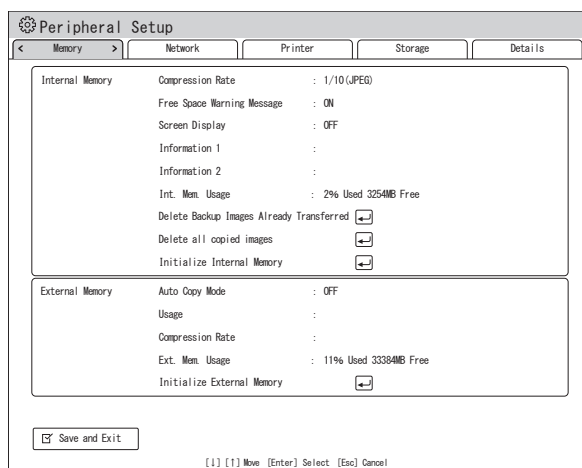

Category	Item	Value	Description
Internal Memory	Compression Rate	1/1 (TIFF) 1/5 (JPEG) 1/10 (JPEG) 1/20 (JPEG)	Select the compression rate of image data to be recorded.
	Free Space Warning Message	ON OFF	ON: When the number of recordable images that can be saved in the internal storage device is reduced to 20, a warning message appears in the observation screen. OFF: The warning message is not displayed.
	Screen Display	ON OFF	ON: The number of recordable images in the internal storage device is displayed in the observation screen. OFF: The number of recordable images in the internal storage device is not displayed in the observation screen.
	Information 1	Press the [Enter] key to enter user's notes.	User's notes can be entered.
	Information 2	Press the [Enter] key to enter user's notes.	User's notes can be entered.
	Int. Mem. Usage		The usage rate and free space of the internal storage device are displayed.
	Delete Backup Images Already Transferred	Press the [Enter] key to display the message window.	From among the image data of each examination stored in the internal storage device, all image data already transferred to the FTP server is deleted at one time. Image data is deleted on an examination basis. If any image data is not yet transferred, no image data in the examination will be deleted. This function is valid when "Used" is selected for "Usage" in "Network" in the Details tab.
	Delete all copied images	Press the [Enter] key to display the message window.	If all image data of an examination stored in the internal storage device have already been copied to an external storage device, the entire image data of the examination will be deleted. Image data is deleted for each examination.
	Initialize Internal Memory	Press the [Enter] key to display the message window.	If you execute initialization, any previous data on the internal storage device is lost and you cannot restore it. Check the contents carefully before initialization.

Category	Item	Value	Description
External Memory	Auto Copy Mode	ON OFF	<p>OFF: Images recorded in the internal storage device during an examination are not copied to an external storage device automatically.</p> <p>ON: Images recorded in the internal storage device during an examination are also copied to an external storage device automatically (simultaneous recording).</p> <p>Note</p> <ul style="list-style-type: none"> • When "ON" is selected, attach an external storage device to this product before starting an study. • Use the external storage device only with this product you currently use. Do not share it with other processors. • The images in the internal storage device can be copied manually to an external storage device after an examination is finished.
	Ext. Mem. Usage		The usage rate and free space of the external storage device are displayed.
	Initialize External Memory	Press the [Enter] key to display the message window.	When initialization is executed, all the data in the external storage device are deleted and cannot be recovered. Before executing initialization, thoroughly check the content of the external storage device.
<p>Remarks</p> <ul style="list-style-type: none"> • The compression rate is just a guide and differs depending on the image to be saved. "1/1 (TIFF)" means saving without compression. Saving takes time. Also, it consumes a large capacity, so check the available capacity before saving. Do not change the compression rate while saving since images may not be recorded normally. • For details on the available external storage device, see "8.8.1 External Storage Device". • Do not remove the external storage device while the display for the external storage device flashes in orange. If the external storage device is removed while the display flashes in orange, it may damage the data being copied or the external storage device itself. • The term "initializing the external storage device" means erasing the index area (contents area). This product cannot initialize the entire storage device. When initializing the entire storage device, use a personal computer. • If the same external storage device is used over a long time, the processing speed of the external storage device may decrease (due to fragmentation). If this happens, initialize the entire storage device using a personal computer. 			

Note

- For the operations on the menu screen, refer to the description of basic setup operations.
→ "5.4.1 Basic Setup Operations"

5.4.3 Printer Tab

Configure use of the printer connected to this product, the number of prints, and the multi-print function. The printer to be used needs to be installed in advance. Installation of the printer is performed by our service personnel.

Turn on the printer before setting the device. The settings of this product are not applied to the printer while the printer power is off.

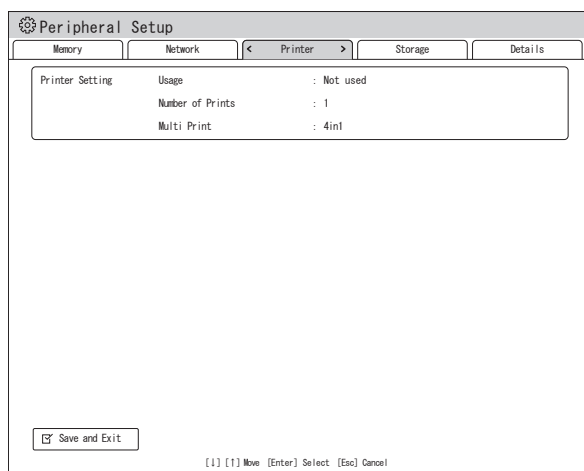

Category	Item	Value	Description
Printer Setting	Usage	Not used Printer model name	Select the model name of the connected printer or "Not used". When "Not used" is selected, all items in the "Printer" tab are disabled.
	Number of Prints	1 to 4	Select the number of prints.
	Multi Print	4 in 1 1 in 1 Apply Printer Setting	Select the number of images to be printed on one sheet of printing paper. Items displayed in the setup screen vary depending on the connected printer. 4in1: Prints four images on one sheet. 1in1: Prints one image on one sheet. Apply Printer Setting: Prints images for the number set on the printer side.

Remarks

- Some settings may be fixed depending on the printer to be used.
- The print size is fixed.
- When observation is performed while the printer connected with the RS-232C interface is turned off, the error message "Printer cannot be recognized. Check the printer power and cable connection." is displayed. To erase the error message, set "Not used" for "Usage" in the Printer Setting by referring to the above procedure.

Note

- For the operations on the menu screen, refer to the description of basic setup operations.
→ "5.4.1 Basic Setup Operations"

5.4.4 Details Tab

This product can save images to an FTP server via a network. Network settings are performed by our service personnel.

This section explains the settings for the images to be saved onto the FTP server via the network.

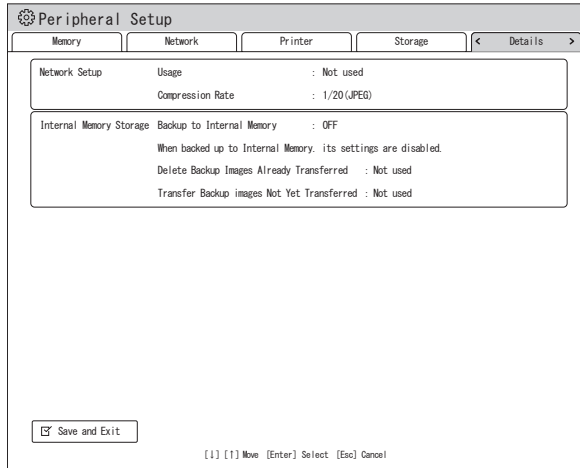

Category	Item	Value	Description
Network Setup	Usage	Used Not used	When “Used” is selected, images can be saved onto the FTP server. In addition, “Backup to Internal Memory” is automatically changed to “OK”. When “Not used” is selected, all items in the “Details” tab are disabled.
	Compression Rate	1/1 (TIFF) 1/5 (JPEG) 1/10 (JPEG) 1/20 (JPEG)	Select the compression rate of image data to be saved.
Remarks <ul style="list-style-type: none"> The compression rate is just a guide and differs depending on the image to be saved. “1/1 (TIFF)” means saving without compression. Saving takes time. Also, it consumes a large capacity, so check the available capacity before saving. Do not change the compression rate while saving since images may not be recorded normally. 			

Category	Item	Value	Description
Internal Memory Storage	Backup to Internal Memory	ON OFF	When "ON" is selected, images to be stored on the FTP server in the network are also backed up onto the internal storage device.
	Delete Backup Images Already Transferred	Used Not used	When "Used" is selected, if all image data of an examination stored in the internal storage device has already been transferred to the FTP server, the entire image data of the examination will be deleted at the end of the examination. If any image data is not yet transferred, no image data will be deleted.
	Transfer Backup Images Not Yet Transferred	Used Not used	When "Used" is selected, if any image data of the previous examination remains in the internal storage device, all image data of the previous examination will be transferred at the beginning of the next examination. Image data of the previous examination that are sent again will not be deleted from the internal storage device even if "Used" is selected for "Delete Backup Images Already Transferred".
Remarks <ul style="list-style-type: none"> When there is no free space on the internal storage device, images that have been backed up (images transferred via the network and images copied to external media) are deleted, starting from the oldest, to secure free space. When the internal storage device is filled with image data not yet copied to an external storage device or those not yet transferred to the FTP server, images are not backed up but are transferred to the FTP server. To resume backup operation, send the images to the network or copy them to the external storage device to secure an enough free space. 			

Note

- For the operations on the menu screen, refer to the description of basic setup operations.
→ "5.4.1 Basic Setup Operations"

5.5 Other Settings

5.5.1 Registering, Calling Up and Editing and Deleting Image Setup Page

The tone settings on the observation screen can be adjusted for each scope type, and a maximum of 5 patterns can be stored.

The desired name can be set for each preset settings. When a preset is specified on the Image Setup Page screen, the image can be displayed with the preset tone.

<Registering Image Setup Page>

- (1) Press the [Image] key to display the Image Setup Page screen.

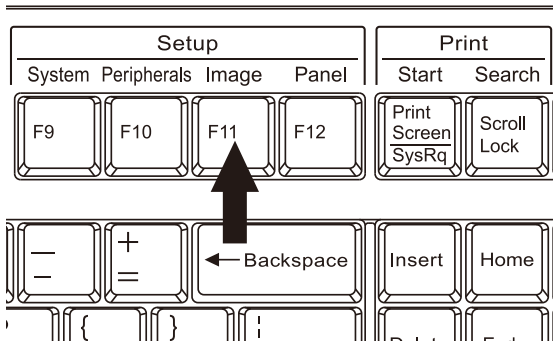

- (2) Select a list number for which the image setup page name is “Empty” and press the [Enter] key.

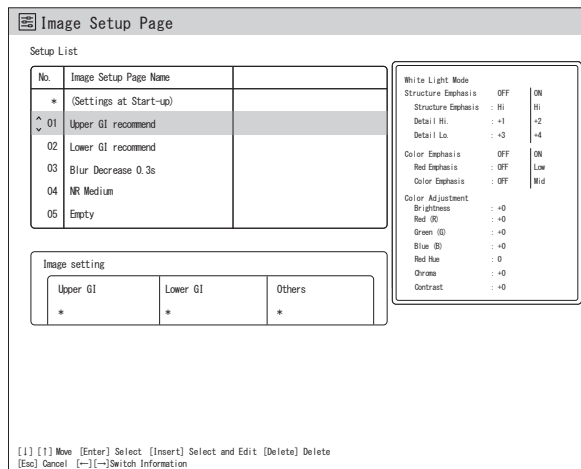

(3) The confirmation message appears. Select “Register” and press the [Enter] key.

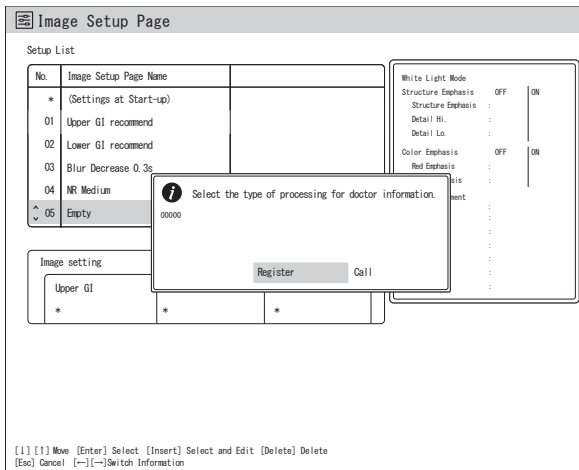

Note

- When “Settings at Start-up” or an already registered image setup page name is selected for “Image Setup Page Name”, either “Register” or “Retrieve Settings” can be selected.
- Registered image setup page names cannot be registered and the image setup page cannot be left blank.

(4) Enter the image setup page name up to 20 characters and press the [Insert] key.

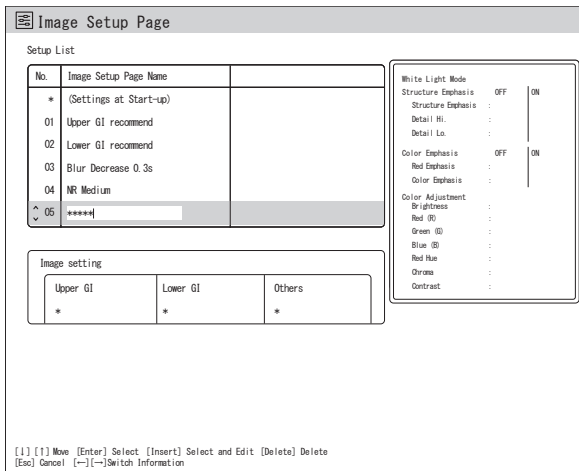

- (5) Select a tab and use the [←] and [→] keys to switch between Scope Systems and Scope Common. Select a scope type and press the [Enter] key.

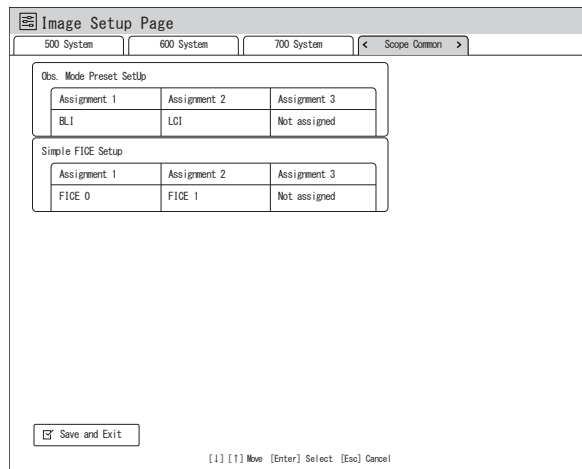
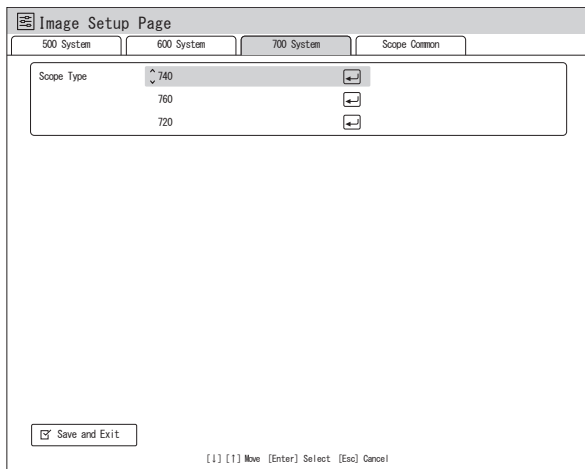

Category	Item	Value	Description
500 System 600 System 700 System			Settings on the Normal Light/FICE, Special Light 1, Special Light 2 and Mode Common tabs can be performed for each endoscope.
Scope Common	Obs. Mode Preset Setup	Not assigned Special Light Ob. Preset Setup No.1 to No.3 FICE 0 to 9	→ “5.3.8 Special Light Observation Preset Setup” Note <ul style="list-style-type: none"> If an item is not registered as a special light observation preset, the item is not displayed in the pop-up menu.
	Simple FICE Setup	Not assigned FICE 0 to 9	When a FICE set number is assigned, each pressing of the scope switch to which “FICE” is assigned changes the function to be selected in order of FICE “ON” and call up of FICE set number of “Assignment 1” → call up of “Assignment 2” → call up of “Assignment 3” → FICE “OFF”. → “4.2.7 Endoscope Tab” → “5.3.3 Setting FICE”
Remarks <ul style="list-style-type: none"> To cancel the assignment settings, select “Not assigned” by using the same procedure and press the [Enter] key to finalize the setting. 			

- (6) The tone can be adjusted for each observation mode such as Normal light/FICE, BLI/BLI-brt and LCI.

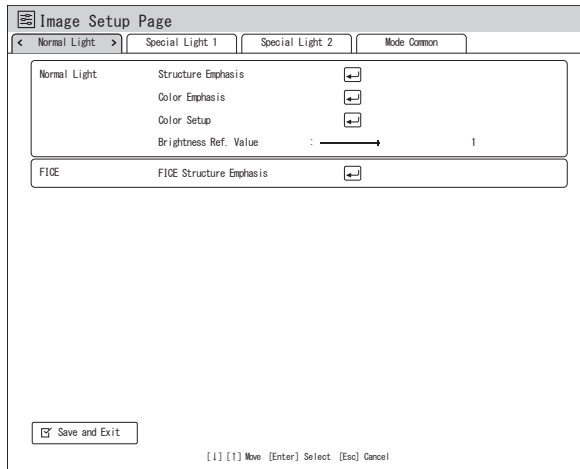

Category	Item	Value	Description
Normal Light/FICE Special Light 1 Special Light 2	Structure Emphasis		➔ “5.3.2 Structure Emphasis Settings”
	Color Emphasis		➔ “5.3.4 Tone Settings”
	Color Setup		➔ “5.3.5 Color Adjustment Settings”
	Brightness Ref. Value		The brightness reference value at the time of observation is set. This function is the same as the brightness adjustment function.
Mode Common	Noise Reduction	OFF Low Mid Hi	The noise reduction function reduces noise on the image. However, if noise reduction is applied strongly, the displayed image may look unnatural (e.g. blurring of fine structures). When noise reduction is applied, the following indication is displayed on the screen. (“Low”, “Mid” and “Hi” indicate the level of noise reduction.) NR: White (Low), Green (Mid) or Yellow (Hi)
	Hyper-Tone	OFF Low Mid Hi	When Hyper-Tone is applied, the brightness of the dark part of the subject can be adjusted. If Hyper-Tone is applied strongly, noise on the dark part of the subject may become noticeable. When hyper-tone is applied, the following indication is displayed on the screen. (“Low”, “Mid” and “Hi” indicate the level of noise reduction.) HT: White (Low), Green (Mid) or Yellow (Hi)
	Aid Brightness	OFF Low Hi	This function increases the brightness level of the area where light hardly reaches in the observation screen. However, the observation screen may become grainy.
	Shake Reduction Mode	OFF 0.1 to 0.5 1.0	The image of the highest contrast within the specified second can be obtained.

(7) Move the cursor to “Save and Exit” and press the [Enter] key.

Note

- When the settings are performed for multiple scope types, repeat Steps (5) to (7).

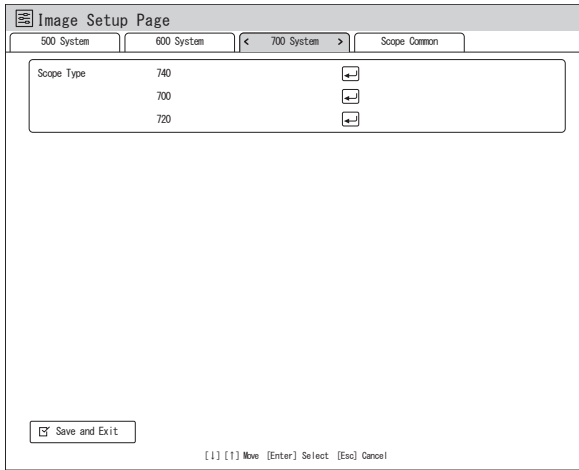

(8) Operation returns to the Image Setup Page screen. Press the [Enter] key with the registered “Image Setup Page Name” selected. The settings are loaded and operation returns to the observation screen.

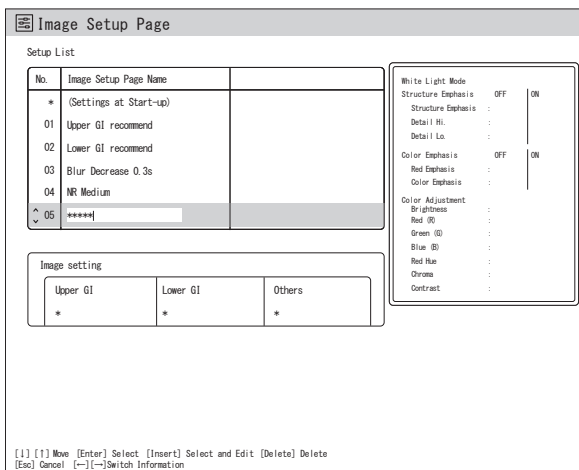

<Detailed Information on Image Setup Page>

When the endoscope is connected and the Image Setup Page screen is displayed during an examination, the image settings are displayed on the detailed information area.

- (1) Press the [Image] key to display the Image Setup Page screen. Select a registered image setup page name using the [↑] and [↓] keys.
- (2) Use the [←] and [→] keys to switch the display in the detailed information area to check the settings.

Note

- When the examination is not in progress, no settings are displayed in the detailed information area.
- The information display switches according to the settings on the Special Light Observation Preset Setup screen.

➔ “5.3.8 Special Light Observation Preset Setup”

• Normal

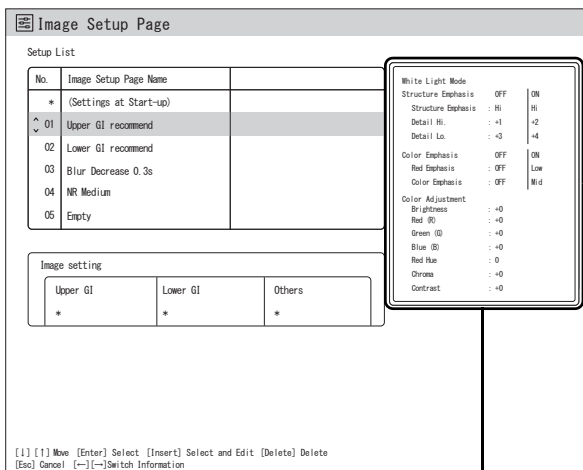

Detailed Information

• light BLI

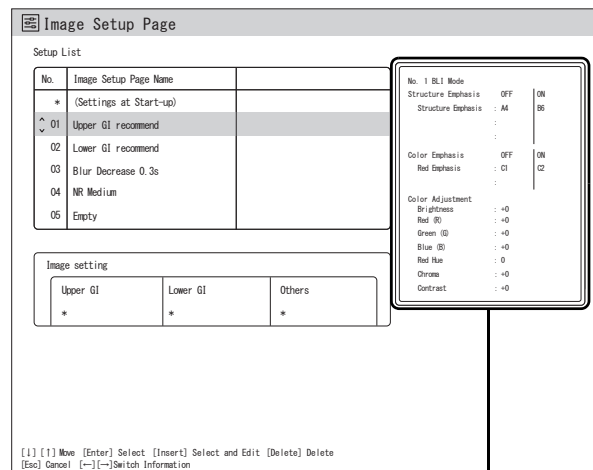

Detailed Information

<Calling Up Image Setup Page>

- (1) Press the [Image] key to display the Image Setup Page screen. Select a registered image setup page name using the [↑] and [↓] keys.
- (2) Press the [Enter] key. The confirmation message is displayed. Select “Call” and press the [Enter] key. The selected settings are loaded and operation returns to the observation screen.

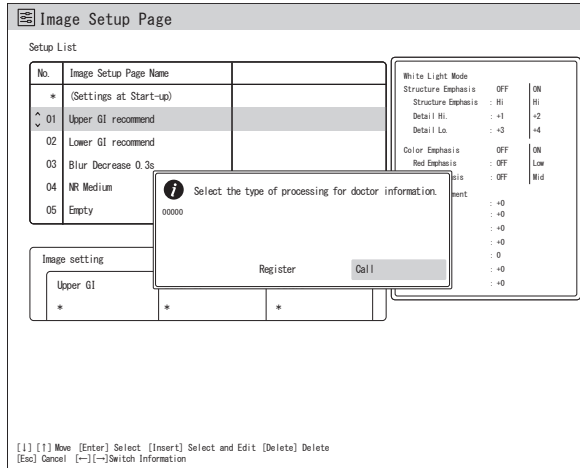

Note

- When “Settings at Start-up” is selected from the list, only “Retrieve Settings” is enabled in the confirmation screen.

<Deleting Image Setup Page>

- (1) Press the [Image] key to display the Image Setup Page screen. Select a registered image setup page name using the [↑] and [↓] keys.
- (2) Press the [Delete] key. The confirmation message is displayed. When “Yes” is selected and then the [Enter] key is pressed, the image setup page is deleted.

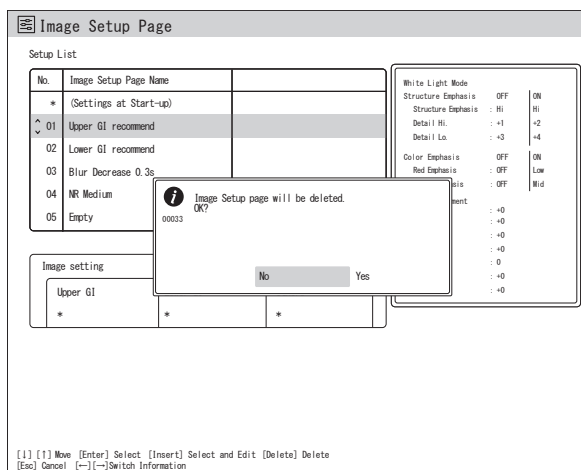

<Image Setting>

When the endoscope is connected and an examination is started, color adjustment data for “Upper GI”, “Lower GI” or “Others” set on the Image Setup Page screen is loaded according to the target region of endoscopic observation.

Upper GI: Endoscope whose name begins with “EG”

Lower GI: Endoscope whose name begins with “EC”

Others: Other than above

- (1) Press the [Image] key to display the Image Setup Page screen. Select the image setting using the [↑] and [↓] keys.
- (2) Use the [←] and [→] keys to select the endoscope category.
- (3) Press the [Enter] key. The image setup page names are displayed on the pop-up menu.
- (4) Select the name of the image setup page to be assigned and press the [Enter] key.

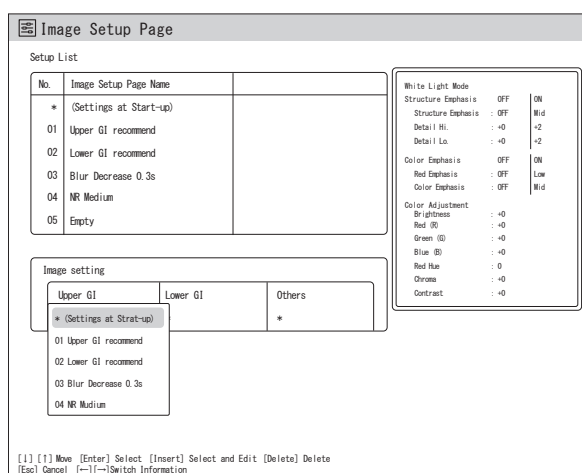

5.5.2 Index Image Display

When a Full HD monitor is connected and the screen resolution is set to Full HD, the last four index images stored in the internal storage device are displayed. They cannot be displayed while in the SXGA mode.

Among the four images, the topmost image is the newest one. When a new image is recorded, each image moves to the lower frame.

Screen resolution setup

→ “4.2.5 Basic Setting Tab”

Index image display setting

→ “4.2.3 Function Tab”

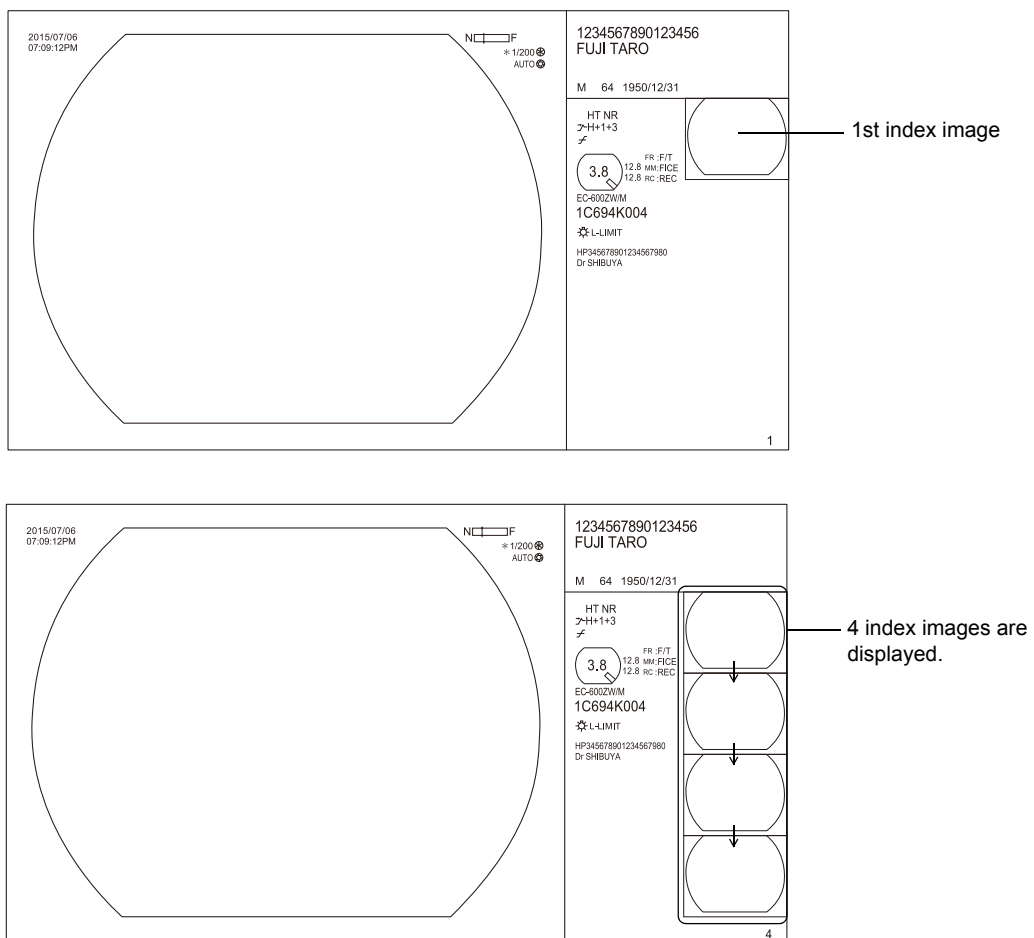

5.5.3 Setting Freeze Mode

Set the freeze mode to be assigned to the scope switch.

- (1) Press the [System] key on the keyboard. The System Setup screen appears.

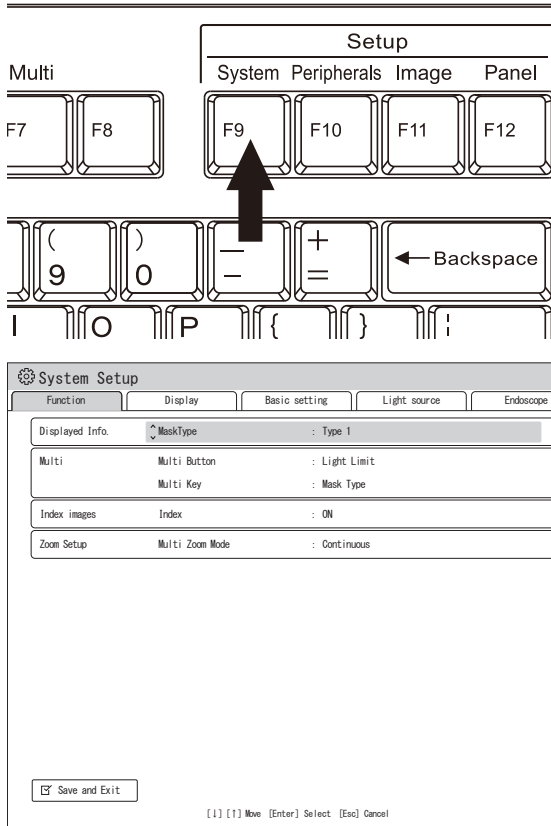

- (2) On the “Endoscope” tab, move the cursor to “Freeze Mode” in “Freeze Mode Setup” and press the [Enter] key. When a pop-up menu is displayed, select the function to be used.

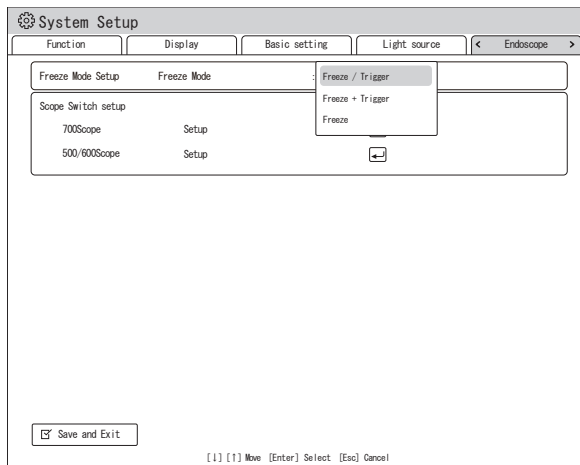

Note

- When “Freeze” is selected in “Freeze Mode”
If the 600 system scope or 500 system scope, except the ultrasonic endoscope, is connected but the trigger or record function is not assigned to the RC switch or Switch 4 on the endoscope, the trigger function is automatically assigned to the RC switch or Switch 4.

- For 700 system scopes, if “Freeze / Trigger”, “Freeze + Trigger” or “Trigger” is not assigned, images cannot be captured.

➔ “4.2.7 Endoscope Tab”





5.5.4 Setting Multi Zoom Mode

The type of zoom operation that is applied when an endoscope with the optical zoom function is used in combination with this product.

This setting is effective only for endoscopes that support the multi zoom mode. For details on each operating mode, see the operation manual of endoscopes that support the multi zoom mode.

Endoscopes that do not support the multi zoom mode operate in the continuous mode, regardless of this setting.

The optical zoom operation and the focus meter display on the upper right corner of the observation screen change according to the selected multi zoom mode.

Operating mode	Optical zoom operation	Focus meter display
Continuous	The focus position changes in a stepless manner.	
5 Step	The focus position changes in 5 steps.	
3 Step	The focus position changes in 3 steps.	
2 Step	The focus position changes in 2 steps.	

Zoom Setup

→ “4.2.3 Function Tab”

5.5.5 Lap Time Display

The lap time can be displayed on the observation screen.

When a Full HD monitor is connected and the screen resolution is set to Full HD, the lap time can be displayed. The lap time function needs to be assigned to the Multi button, Multi key, or scope switch.

- Lap time setup
 - ➔ “4.2.4 Display Tab”
- Multi button setup
 - ➔ “4.2.3 Function Tab”
- Multi key setup
 - ➔ “4.2.3 Function Tab”
- Scope switch setup
 - ➔ “4.2.7 Endoscope Tab”
- How to use the lap time function
 - ➔ “7.17.3 Lap Time Function”

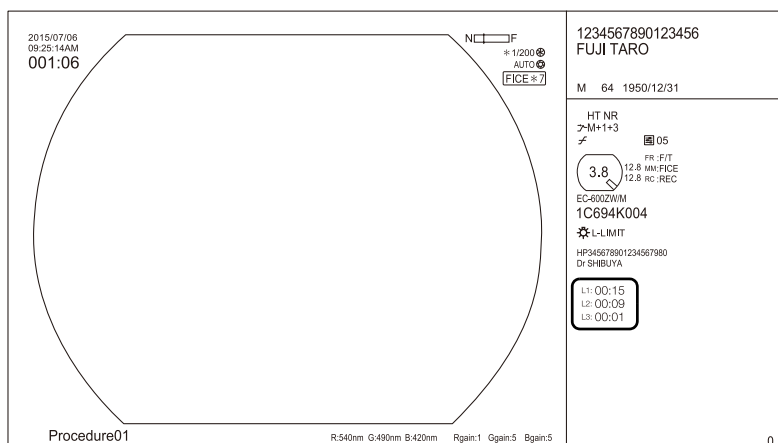

6.1 Installing and Connecting the Equipment

Install the system according to “Chapter 4 System Installation and Initial Settings”.

Note

- If the battery in the processor discharges, it may impede the clock function displayed on the monitor (the clock may lose time). If the processor has been left unused for more than three months, turn on the power to the processor to charge the battery for about three hours. (It is not necessary to connect the endoscope or turn on the light.)
- If the clock displayed on the monitor is not correct, set the date and time again.

6.2 Preparing Related Equipment

Inspect the following related equipment as per instructions provided in each operation manual.

- Endoscope
- Monitor
- Water tank
- Suction unit
- Endotherapy device
- Mouthpiece
- Water pump
- Endoscopic CO₂ Regulator
- Electrosurgical unit, etc.
- Dustproof filter

Note

- Some pieces of related equipment are not reprocessed before shipping from the manufacturer. Reprocess them for the first time prior to use as per instructions provided in respective operation manuals.

6.3 Operation Check of Processor

WARNING

- While the light is turned on, do not look directly into the light coming from the light guide at the distal end of the endoscope. Viewing the light from the light guide directly may damage your eyes.

Note

- With regard the light seen through the ventilation holes, there are no safety problems.

- (1) Before use, check whether the dustproof filters are clogged. If they are clogged, a device malfunction or failure may occur.

Note

- For details on how to clean the dustproof filters, see Chapter 9.
→ “9.3 Cleaning the Dustproof Filters”

- (2) Make sure that no water has splashed on or rust has formed in the electric connector socket, scope connector socket and memory slot.

- (3) Connect the endoscope.

Note

- For details on how to connect the endoscope, refer to Chapter 7.
→ “7.2 Connecting the Endoscope and Equipment”

- (4) Turn on the power to the cart.

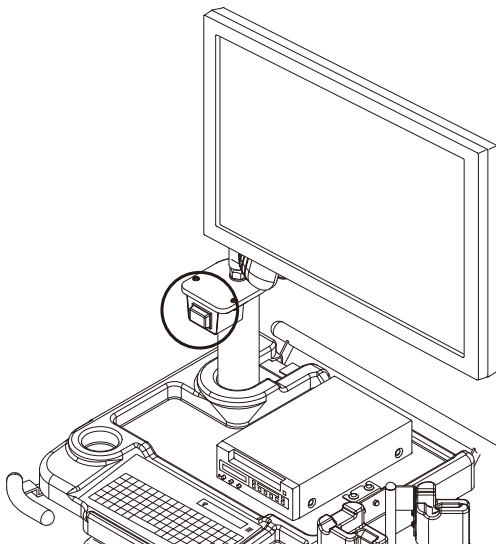

- (5) Turn on the power to this product.

The power indicator lamp lights up. The EXAM. button and “ACTIVE” lamp light up in blue. The observation screen is displayed on the monitor.

Note

- When the scope is not connected, the EXAM. button and “STANDBY” light orange. Connect the scope, and then press the EXAM. button.

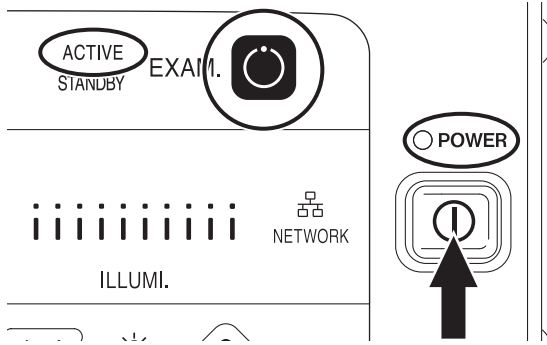

- (6) Press the Light button.

The Light button and “ON” light blue, and the light switches on. Furthermore, the indicator of “ILLUMI.” lights blue.

Note

- When the scope is not connected, the light does not switch on, and the Light button lights orange. Connect the scope, and then press the Light button.

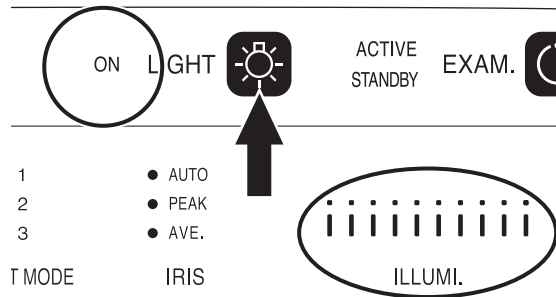

- (7) Put the distal end of endoscope close to a black sheet of paper and check the reflected light. When two points of light are seen, the system is operating normally. If only one point of light or no light is seen, stop using the equipment immediately, turn off the equipment and consult your local FUJIFILM dealer.

Note

- If the light emitted from the distal end of endoscope is viewed directly, it may cause damage to the eyes.

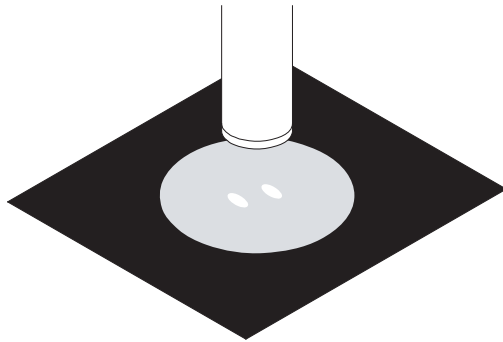

- (8) Apply your palm against the distal end of the endoscope, and make sure that the indicator level changes when you move your hand toward and away from the distal end.

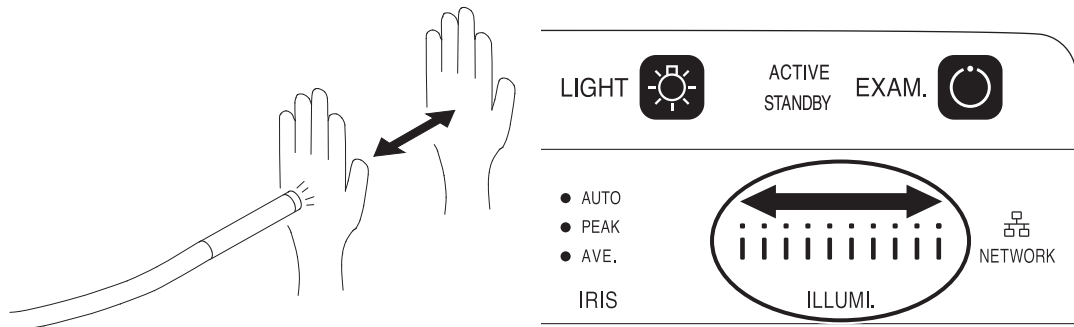

- (9) Apply the palm of the hand to the distal end of endoscope and make sure that the image of a part of the hand can be seen.
 Press the BLI button to make sure that the BLI lamp and monitor image are switched.
 When necessary, perform Steps (1) to (5) in “5.3.5 Color Adjustment Settings”.

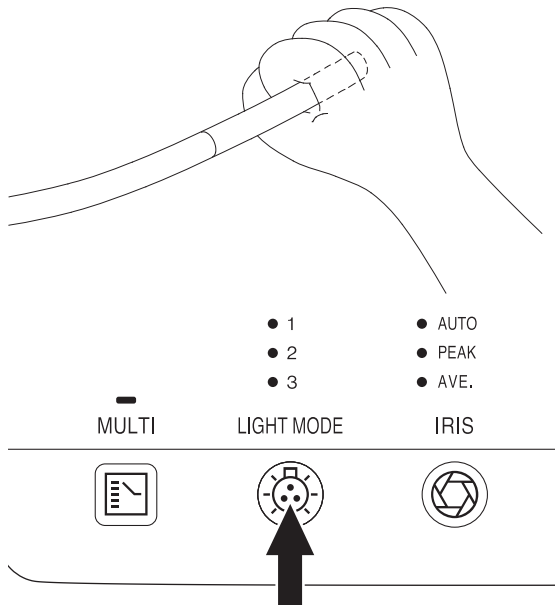

- (10) Press each scope switch to ensure that the functions are assigned properly.

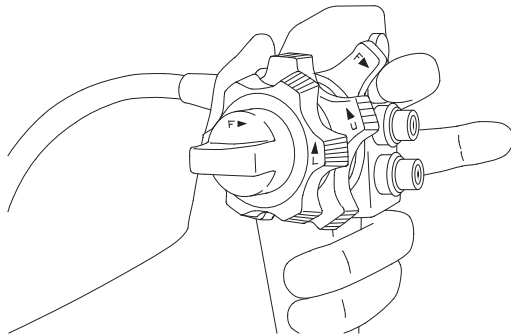

- (11) When the foot switch is used, step on the button to which “Freeze” is assigned to ensure that the image is frozen.
- (12) Press the Pump button to make sure that the air supply pump’s operation switches in the order of “H”, “M”, “L”, off, and “H”.

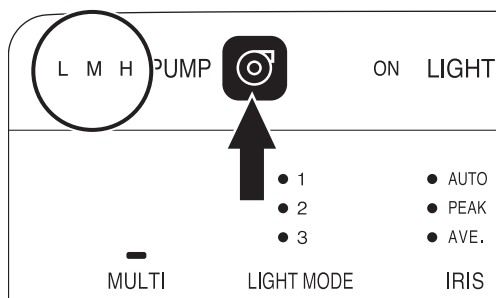

- (13)** Press the Pump button to set the air supply pump's operation to "H."
 Leave the distal end of the endoscope in the air, press the air/water valve of the endoscope, and make sure that water comes out of the air/water nozzle.

Note

- Be careful of the direction when water comes out.

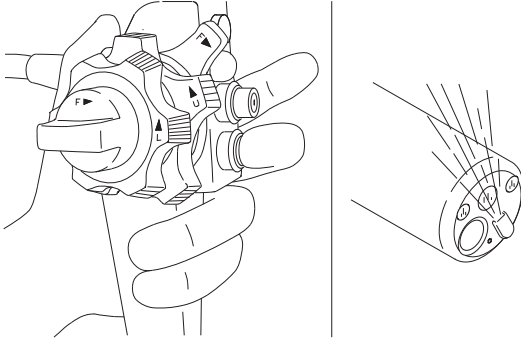

- (14)** Immerse the distal end of the endoscope in the water, cover the center hole on the air/water valve with a finger, and make sure that air comes out of the air/water nozzle. Then, take your finger off the hole and make sure that no air comes out of the air/water nozzle.

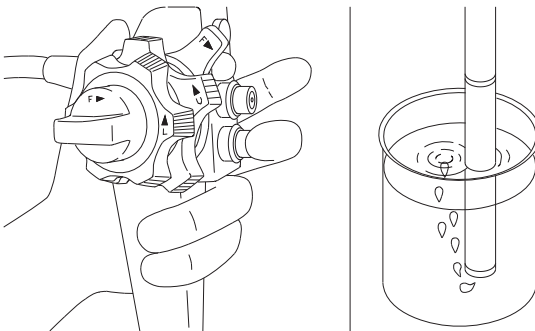

- (15)** Turn off the power to this product.
 The operation check is now completed.

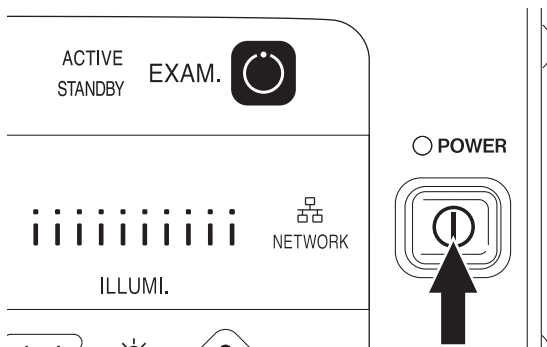

6.4 Registering and Calling Adjustment Value

You can register up to five different patterns of the values adjusted in “5.5.1 Registering, Calling Up and Editing and Deleting Image Setup Page” as image setup pages. Registered image setup pages can be called up later.

→ “5.5.1 Registering, Calling Up and Editing and Deleting Image Setup Page”

6.5 Registering the Patient Information

Press the [Patient Entry] key on the keyboard. Register the patient information.

→ “5.2 Registering and Editing Patient Information”

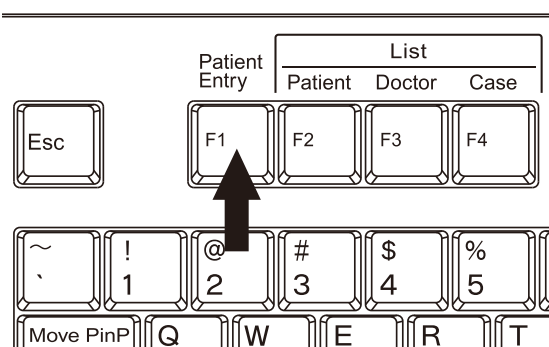

6.6 Calling up the Patient Information

- (1) Press the [Patient] key on the keyboard. The Patient List screen is displayed.

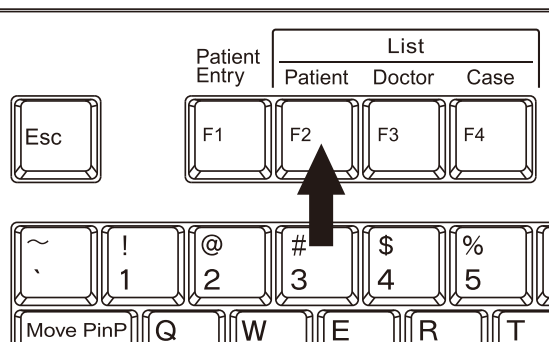

- (2) Using the [↑] and [↓] keys, place the cursor on the patient information and then press the [Enter] key. The selected patient information is displayed on the observation screen.

→ “5.2.2 Calling Up Patient Information”

Ensure that no debris or foreign matter adheres to this product.
Adhesion of debris may cause malfunction or failure of the devices.

→ “Chapter 9 Storage and Maintenance”

Introduction

The operation flow of this product is shown below. Refer to each section by following this flowchart.

1 Perform inspections before use.

→ “Chapter 6 Preparation and Inspection of the System”



Note

- To change the system settings such as the scope switch settings ^{**1} and index image display ^{**1}, see “4.2 Initial Settings at the Time of Installation”.

2 Connect the endoscope.

→ “7.2 Connecting the Endoscope and Equipment”



Note

- The location of the electrical connector socket is shown in “3.1 Front Panel”.

3 • Turn on this product.

→ “7.4 Supplying Power to the Equipment”

→ “7.6 Turning On the Light Source”

→ “7.18 Starting the Examination”



- Second examination or later.

→ “7.19.2 Starting the Second Examination or Later”

Note

- The locations of the power button and the EXAM. button are shown in “3.1 Front Panel”.

4 Call up the user settings. *1

→ “4.2.10 Setting the Doctor's Name”



→ “5.5.1 Registering, Calling Up and Editing and Deleting Image Setup Page”

5 Enter the patient data. *1

→ “5.2 Registering and Editing Patient Information”

6 Check the information display on the monitor.

→ “3.9 Data Display on the Observation Screen”

7 • Check the endoscopic image. Change the observation settings. *1

→ “5.5.2 Index Image Display”

→ “7.10 Switching Observation Mode” to “7.17 Data Display Operation”



- Record the observed images. *1

→ “Chapter 8 Image Recording”

8 Finish the examination.

→ “7.19.1 Finishing the First Examination”

→ “7.19.3 Finishing All Examinations”

Note

- The locations of the power button and the EXAM. button are shown in “3.1 Front Panel”.

Note

- Finish the examination with the EXAM. button during standby in order to reduce the environmental burden.

*1 This step may be skipped depending on the examination method.

7.1 Preparing the Equipment

- (1) Turn OFF the power to the light source, processor and cart.
- (2) Move the cart equipped with the system to the place where it is to be used.
Lock the casters of the cart.

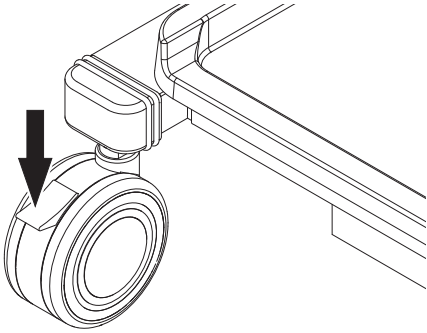

- (3) Plug the power cord from the cart into a protective earth receptacle.

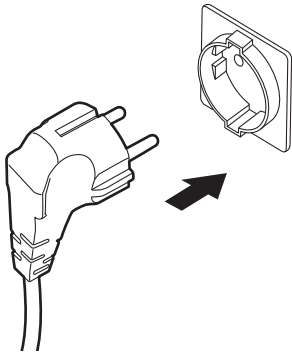

- (4) Mount the suction bottle on the suction unit.

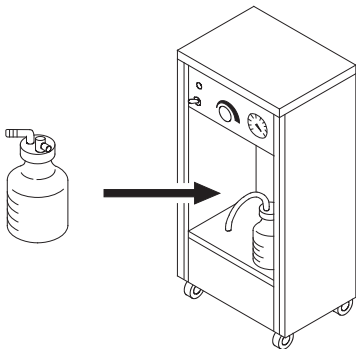

- (5) Hook the water supply tank filled with sterilized water to about 80% on the left side surface.

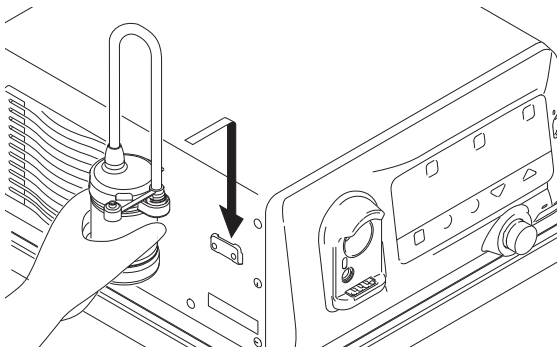

7.2 Connecting the Endoscope and Equipment

CAUTION

- While the light is turned on, do not look directly into the light coming from the light guide at the distal end of the endoscope. Viewing the light from the light guide directly may damage your eyes.
- Before connecting the endoscope, ensure that no foreign matter adheres to the scope connector section. If any foreign matter is located within the power supply section, it may cause malfunction or failure of the devices and may also generate heat. If any foreign matter is found, do not touch it directly with your hand but clean equipment as described in this manual after disconnecting the endoscope.
 - ➔ “9.1 Care after Use of Processor”
- Ensure that there is no foreign matter or dirt on the receiving window or on the communication window before connecting the endoscope. If there is any foreign matter or dirt on the receiving window or on the communication window, it may cause malfunction or failure of the devices.
- Make sure that the scope connector including the power-receiving section is thoroughly dry before connecting it to the light source. In addition, make sure that no moisture or foreign matter (such as metallic fragments, chemical residues, water deposits, grease, dust, and gauze fibers) adheres to the power-receiving section. If the connector mount is wet or soiled with foreign matter, it may cause malfunction or failure of the devices.
- Insert it securely all the way so that there are no gaps while it is connected to the endoscope. Do not look into the endoscope connection section. The light of the light source may cause eye damage.
- Keep metals except for the endoscope away from the power supply section. Otherwise, metals may generate heat.
- Immediately after removing the scope connector from the light source, do not touch the light guide prong with your hands since it may be extremely hot. There is a risk of burns. Do not touch the tip of the light guide prong until it has cooled (approximately 5 minutes).
- Set a suction pressure at 40 to 53 kPa or less. The endoscope may adhere to the mucous membrane, resulting in damage to the mucous membrane.
- Do not install the 700 system scope on the scope connector with a 600 system scope or 500 system scope inserted into the electric connector socket.
- To prevent contamination and static electricity, wear protective gear when touching the endoscope.

Note

- To avoid damage or malfunction, turn OFF the processor, and then connect or remove the endoscope. Wait for 5 seconds or more before turning the power back to ON. Do not touch the electrical contacts directly with your hand. Prevent the contacts from exposure to xylocaine spray, etc. Dry the moist contacts of the endoscope before connecting the endoscope to the processor.
- Make sure that the date, time, and patient information are correct before the use.

- To prevent damage or malfunction, press the EXAM. button, make sure that the STANDBY indicator lamp lights up in orange, and then connect or remove the endoscope.
- Connecting the endoscope with moisture on the contacts will cause damage or malfunction, for example, image defects. If an electrical connector socket is not connected to the endoscope, cover the socket with the included protection cap (CC-203) to protect the contacts.

To install the endoscope, turn off this product or press the EXAM. button and wait until “STANDBY” is solid orange. First, connect the endoscope to the scope connector socket.

Note

- Even after turning on the power, do not connect the endoscope while the startup progress bar ■■■■■ is displayed at the upper left side of the screen.

<700 System Scope>

CAUTION

- Ensure that there is no foreign matter or dirt on the receiving window or on the communication window before connecting the endoscope. If there is any foreign matter or dirt on the receiving window or on the communication window, it may cause malfunction or failure of the devices.
- When connecting the endoscope, insert it fully so as to produce no clearance. Do not look into the connecting part of the endoscope. The light emitted from the light source may cause damage to the eyes.

- (1) Insert the scope connector of the endoscope into the scope connector socket until it stops.

Note

- Insert the scope connector straight into the scope socket.

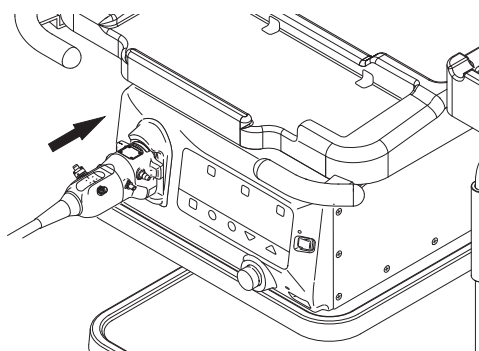

- (2) When connecting a 700 system scope, attach the socket protection cap to the electric connector socket.

Note

- Do not connect a 500/600 system scope to the electric connector socket.

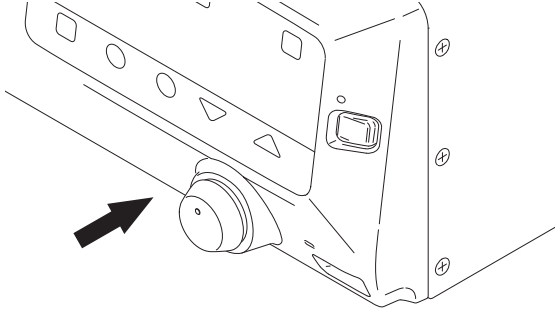

- (3) Hook the water tank filled with sterile water onto the light source.

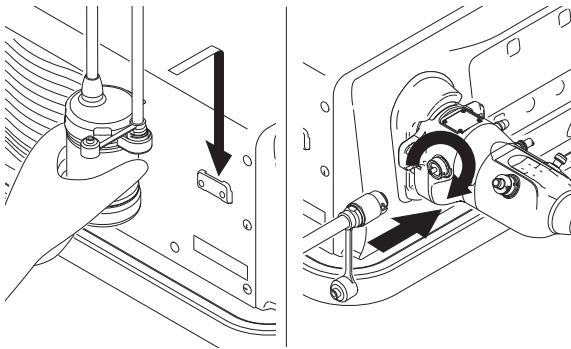

<600 System Scope and 500 System Scope>

- (1) Hold the LG connector of the endoscope with both hands, and then insert it straight into the scope connector socket until it stops.

Note

- Insert the LG connector straight into the scope socket.

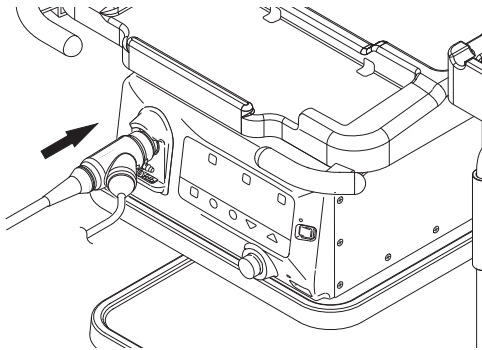

- (2) Remove the protection cap from the electrical connector socket to be connected to the endoscope, and connect the electrical connector.

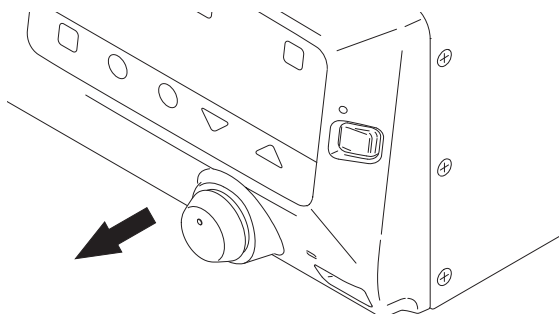

- (3) In alignment with the electrical connector index, rotate the connector clockwise while lightly pressing it.

Note

- Make sure to rotate the electrical connector index 90 degrees clockwise.
- Do not connect more than one endoscope.

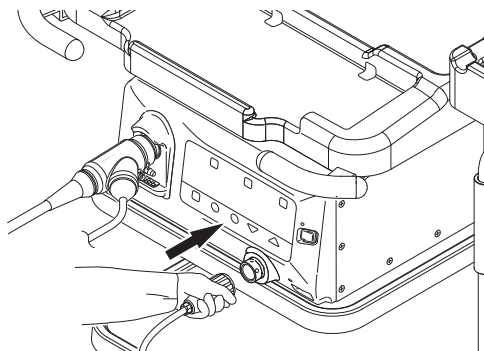

- (4) Hook the water tank filled with sterilized water onto the light source.

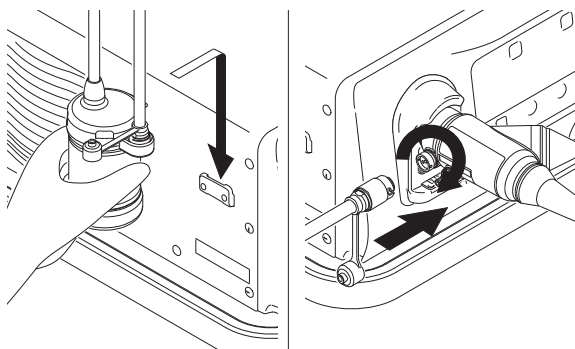

7.3 How to Use the Endoscope and Related Equipment

For details on how to use the endoscope and related equipment, refer to the respective operation manuals.

7.4 Supplying Power to the Equipment

When the power source of this product is switched on, the EXAM. button and “ACTIVE” light blue.

Note

- When the scope is not connected, the EXAM. button and “STANDBY” light orange. Connect the scope, and then press the EXAM. button.
- After turning on the equipment, it takes about 15 seconds before the screen is displayed on the monitor and 60 seconds before the examination can be started. Displayed images do not undergo image processing until “ACTIVE” lights blue.
- Even after turning on the power, do not connect the endoscope while the startup progress bar ■■■■■ is displayed at the upper left side of the screen.
- Do not operate the scope switch until “ACTIVE” lights blue.
- If the equipment is turned on without the endoscope inserted, the air supply pump stops automatically.

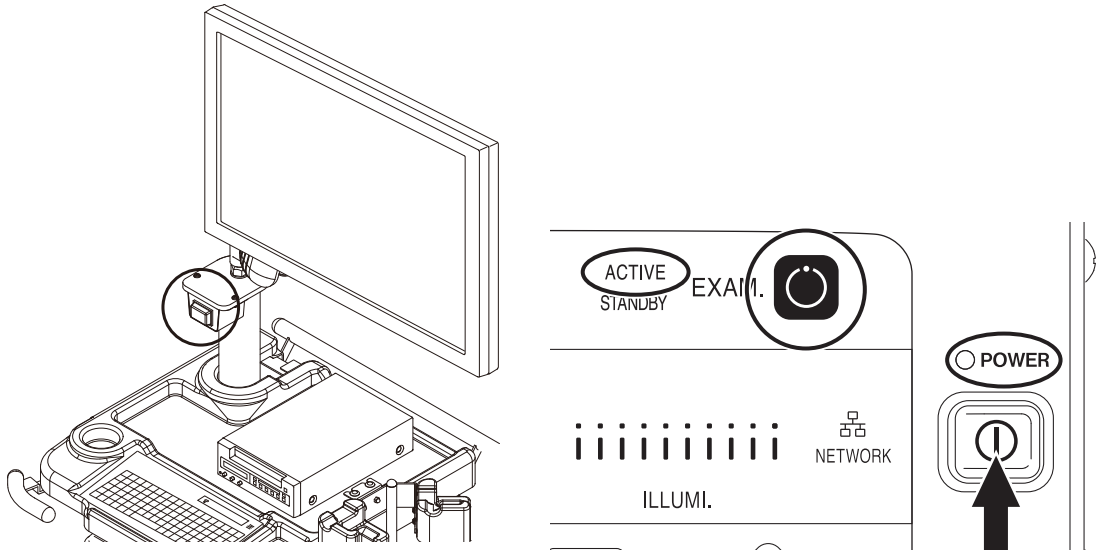

7.5 Operation of Air Supply Pump

Press the Pump button to make sure that the air supply pump’s operation switches in the order of “H”, “M”, “L”, off, and “H”.

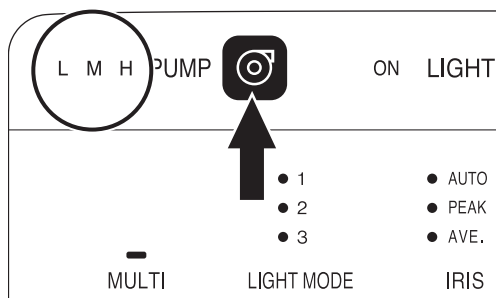

7.6 Turning On the Light Source

CAUTION

- While the light is turned on, do not look directly into the light coming from the light guide at the distal end of the endoscope. Viewing the light from the light guide directly may damage your eyes.

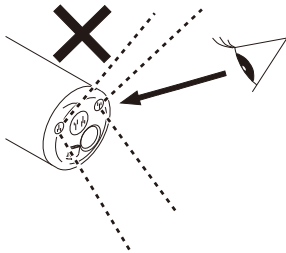

Press the Light button.

The Light button and “ON” light blue, and the light switches on. Furthermore, the indicator of “ILLUMI.” lights blue.

Note

- On this product, the light does not turn on when the scope connector or LG connector of the endoscope is not connected to the scope socket.

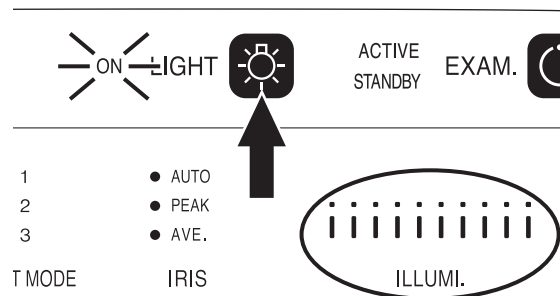

7.7 Turning Off the Light

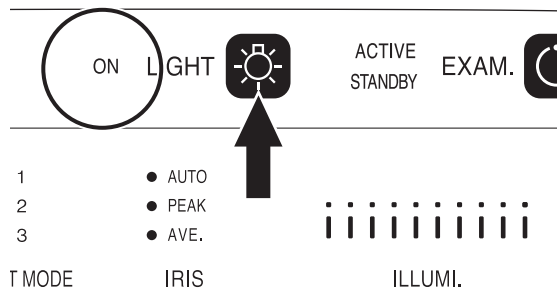

Press the Light button.

The Light button and “ON” turn off, and light emission stops.



7.8 Adjusting the Brightness

To obtain the appropriate brightness for an object, adjust the brightness by pressing the Brightness Adjustment button.

Press  to make the image brighter, and press  to make the image darker.

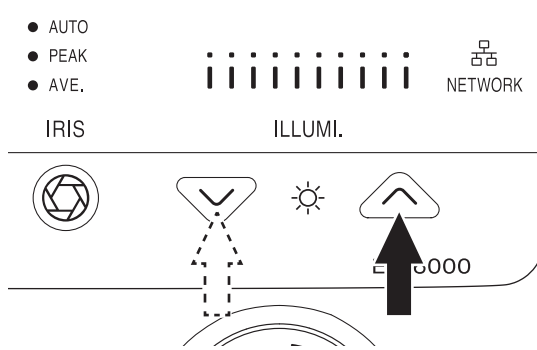

The brightness level can be adjusted from -4 to +5. The level is displayed in the indicator as follows.

Brightness level 0 (standard):



Brightness level -4:



Brightness level +5:



The brightness level can also be confirmed on the monitor.

The brightness level is displayed at the right-hand side of the iris mode display in the range of -4 to +5. However, when the brightness level is "0" (standard), the number "0" is not displayed.

Lv+1 AUTO 

➔ "7.15 Switching the Iris Mode"

7.9 Light Save Function

To avoid the blood of a bleeding patient becoming clotted by the illuminating light, the Light Save Function is used to limit the maximum light intensity of the light.

→ “4.2.6 Light Source Tab”

If Light Limit is switched on when it has been assigned to the Multi-button, the  indicator lights.

→ “4.2.3 Function Tab”

Note

- Blood may become clotted in some cases even if the Light Save Function is used.

(1) Press the MULTI button to which Light Limit was assigned.

The maximum light intensity of the light is limited, and the  indicator lamp above the MULTI button turns on.

“L-LIMIT” is also displayed on the screen of Full HD monitor or SXGA monitor.

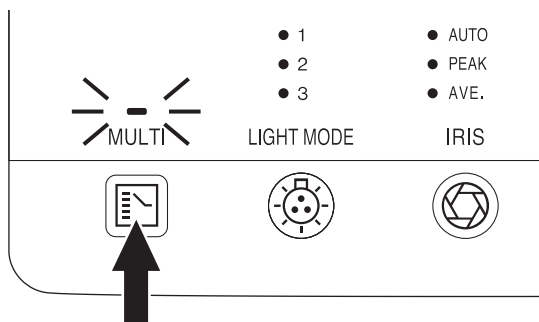

• SXGA mode

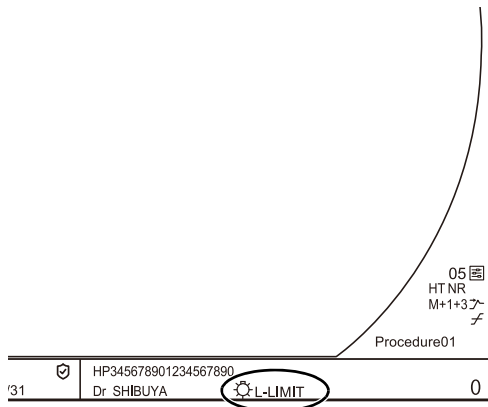

• Full HD mode

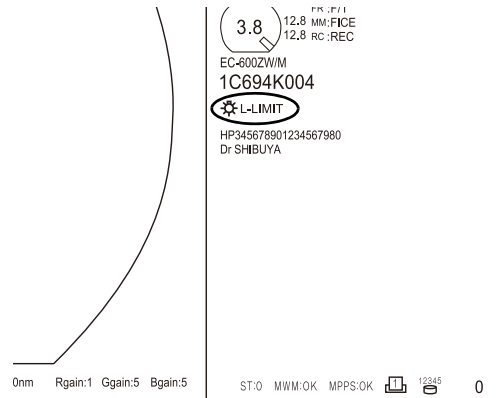

(2) To reset the light intensity to the default, press the MULTI button again.

The light intensity of the light is reset to the default, and the  indicator lamp above the MULTI button turns off.

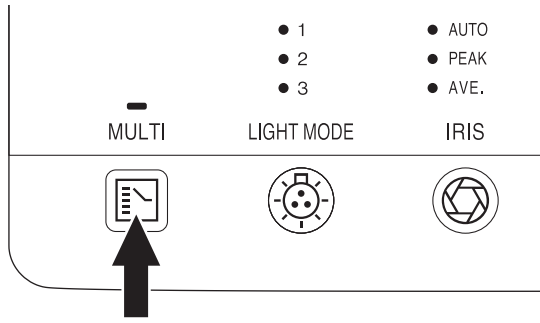

Note

- If the study is completed, Light Limit is cleared.

7.10 Switching Observation Mode

This function processes images that are obtained in accordance with the light mode and then makes the structure and region of the subject to be observed easier to view. Each time the light mode button is pressed, the observation mode (BLI/BLI-bright/LCI) switches in the order configured by the special-light observation presets. The system switches to normal mode when the light mode is "OFF".

Note

- While the observation mode is being switched, the image on the monitor may flicker for a moment. This is not a failure.
 - When FICE is turned "ON" while the tone function is turned "ON", the tone function is automatically turned OFF.
- "7.12 Turning On/Off FICE"

<Endoscopes that can use the special-light observation mode (BLI/BLI-bright/LCI)>

Model
700 system scopes, EB-580S

<Setting the special light observation preset>

To set up the special light observation preset, press and hold the BLI button for two seconds. The setup screen appears.

→ "5.3.8 Special Light Observation Preset Setup"

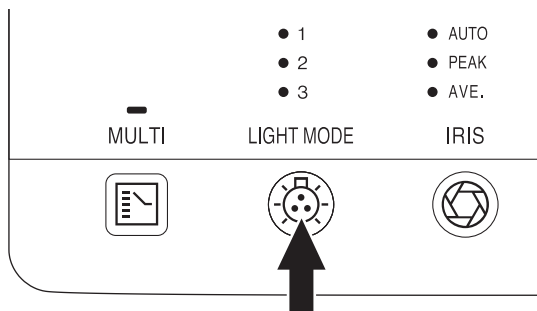

7.11 Turning On/Off Structure Emphasis

Each time the button that was assigned structure emphasis is pressed, the structure emphasis function switches on or off.

When the power is turned on or when an examination is started, this function is set to "OFF".

If Structure Emphasis is switched on when it has been assigned to the Multi-button, the  indicator lights.

<In the case of Normal mode>

When the structure emphasis function is turned on, the following icon appears in the screen.

 SE

The color of the setting value is determined depending on the initial setting as shown below. (The setting value is indicated in parentheses.)

SE (Structure Emphasis): White (Low), Green (Mid) or Yellow (Hi)

<In the case of BLI, BLI-bright or LCI>

When the structure emphasis function is turned on, the following icon appears in the screen.

The character of the setting value is always displayed in white.

A Mode:  n/ ("n" indicates the setting level of A mode.)

B Mode:  /m ("m" indicates the setting level of B mode.)

Note

- When this function is set to off or when this function is not used in relation to other functions, the above characters are not displayed.

<Detail setting>

To configure advanced settings, press and hold the Multi button to which structure emphasis was assigned for about 2 seconds.

The  indicator lamp flashes, and the function setup screen is displayed.

Alternatively, press the "Panel" key on the keyboard.

➔ "5.3.2 Structure Emphasis Settings"

7.12 Turning On/Off FICE

FICE is a spectral image processing function.

FICE extracts spectral images of specific wavelength components from the original image by image processing, assigns each component to R, G and B and displays the pseudocolor image. FICE can enhance color tone to improve visibility of the selected structure and areas of the subject.

Note

- In the BLI, BLI-bright or LCI mode, FICE is not available. Set the light mode to normal mode.
→ “7.10 Switching Observation Mode”
- When FICE is turned “ON” while the tone function is turned “ON”, the tone function is automatically turned OFF.

<Endoscopes that can use FICE>

Model
700 system scopes, 600 system scopes, 500 system scopes *1, EB-580S

*1 Excluding 590 series scope, EG-530UT2, EG-530UT, EG-530UR2 and EG-530UR.

<Turning On/Off FICE>

Each time the [FICE] key on the keyboard is pressed, FICE is turned on or off.

Note

- When FICE is turned “ON” while the tone function is turned “ON”, the tone function is automatically turned OFF.

<Calling Up a FICE Set>

This section describes how to select FICE sets that have already been configured.

- (1) Turn “ON” FICE.
- (2) Enter a one-digit number (among 0 to 9) using the numeric key.
Enter a preset FICE set number using the numeric key.

Calling up a FICE set and FICE setup.

- “5.3.3 Setting FICE”

7.13 Turning On/Off the Tone

Each time the button that was assigned color enhancement is pressed, the color enhancement function switches on or off.

If color enhancement is switched on when it has been assigned to the Multi-button, the  indicator lights.

Note

- When FICE is turned “ON” while the tone function is “ON”, the tone function is automatically turned “OFF”.

<In the case of Normal Mode>

When the tone function is turned ON, the following icon is displayed in the screen.



The color of the setting value is determined depending on the initial setting as shown below. (The setting value is indicated in parentheses.)

RE (Red Emphasis): White (Low), Green (Mid), and Yellow (Hi)

CE (Color Emphasis): White (Low), Green (Mid), and Yellow (Hi)

<In the case of BLI, BLI-bright or LCI>

When the tone function is turned ON, the following icon is displayed in the screen.



The character and color of the setting value are determined depending on the initial setting as shown below. (The setting value is indicated in parentheses.)

CE (Color Emphasis): C1/White (Tone 1), C2/Green (Tone 2), and C3/Yellow (Tone 3)

<Detail setting>

To configure advanced settings, press and hold the Multi button to which color enhancement was assigned for about 2 seconds.

The  indicator lamp flashes, and the function setup screen is displayed.



Alternatively, press the “Panel” key on the keyboard.

➔ “5.3.4 Tone Settings”

7.14 Switching the Shutter Speed

<Manual switching of shutter speed>

Each time the button to which shutter speed has been assigned is pressed, the shutter speed setting is switched between “HIGH” and “NORM.” (standard).

If the shutter speed setting is set to “HIGH” when it has been assigned to the Multi-button, the  indicator lights. If the shutter speed setting is set to “NORM.”, the  indicator switches off. In the screen, the shutter speed is displayed as follows.

“NORM.”: 1/60  The set value is displayed in white.

“HIGH”: 1/200  The set value is displayed in green.

When priority mode is enabled: *1/200  (The setting value is displayed in yellow.)

Note

- The displayed value is the set shutter speed (unit: second).

<Automatic switching when the optical zoom scope is used>

When the optical zoom scope is used, the shutter speed can be automatically switched according to the zoom ratio. The installation is performed by service personnel.

If shutter speed is switched to “HIGH” automatically when it has been assigned to the Multi-button, the  indicator flashes.

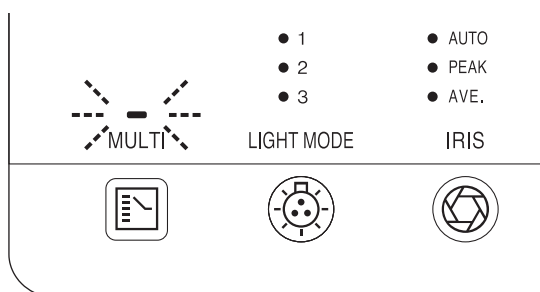

In the screen, the shutter speed is displayed as follows.

1/200  (The set value is displayed using black characters on a white background.)

<Detail setting>

To configure advanced settings, press and hold the Multi button to which shutter speed was assigned for about 2 seconds.

The  indicator flashes, and the function setup screen is displayed.

Alternatively, press the “Panel” key on the keyboard.

→ “5.3.6 Setting the Shutter Speed”

7.15 Switching the Iris Mode

Press the [IRIS] button to select the ALC (automatic light control) mode to control the screen brightness.

The EP-6000 has three iris modes: AVE to control the brightness on the entire screen, PEAK to control the brightness in the highlight areas, and AUTO to set average or peak iris automatically for optimal iris. When the power is turned on, the system is set at the AUTO iris mode.

Each time the [IRIS] button is pressed, the iris mode switches to AVE, PEAK or AUTO.

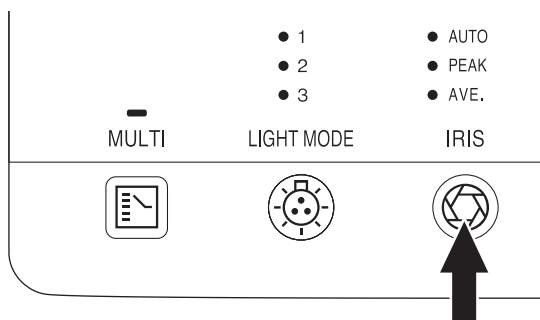

In the screen, the iris mode is displayed as follows.

AUTO: Lv+1 AUTO  The setting is displayed in white.

PEAK: Lv+1 PEAK  The setting is displayed in green.

AVE: Lv+1 AVE  The setting is displayed in green.

Note

- While the light is turned on, the brightness level is displayed next to AUTO/PEAK/AVE.
→ “7.8 Adjusting the Brightness”



The AVE is suitable for a screen that does not have that much difference in brightness.

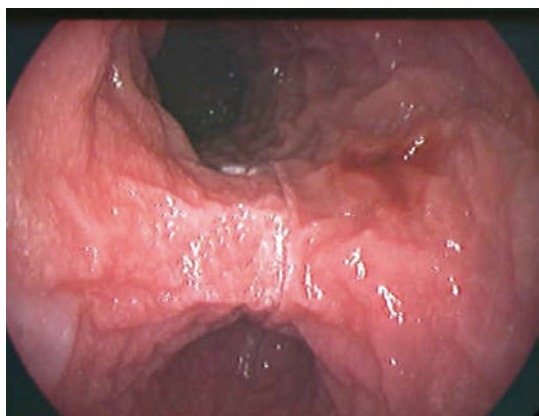

The PEAK is suitable for a screen that has some high brightness parts.

<Detail setting>

Press and hold the Iris Mode button for about two seconds to display the setup screen.

→ “5.3.7 Setting the Iris Mode”

7.16 Adjusting the Electronic Zoom

Display the observation screen and press the [↑] / [↓] keys on the keyboard.

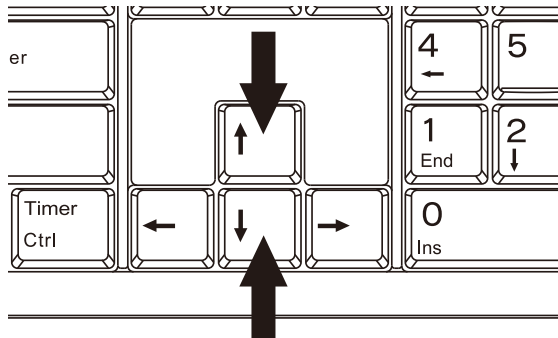

The electronic zoom is switched.

The zoom ratio can be set between $\times 1.00$ and $\times 2.00$ (0.05 steps).

Note

- The zoom ratio of some 530 series scopes is $\times 1.00$ to $\times 1.95$.
- When an optical zoom scope is connected, pressing the zoom switch, while the optical zoom ratio is at maximum, switches to the electronic zoom automatically.

➔ “4.2.9 Setup for Switching the Shutter Speed During Optical Zoom”

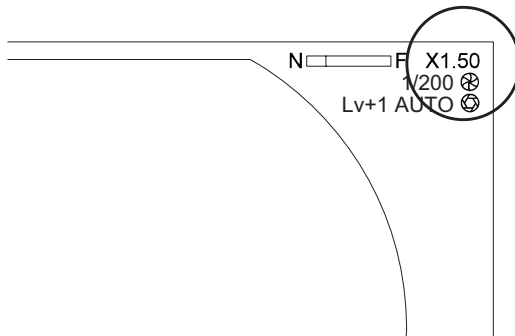

7.17 Data Display Operation

7.17.1 Entering Comments

Comments can be entered on the observation screen.

- (1) Press the [Note] key.
The cursor appears on the procedure name.

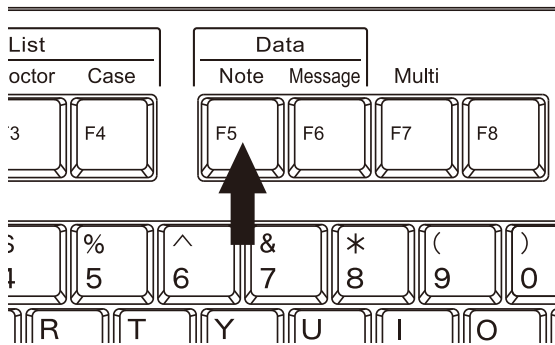

• SXGA mode

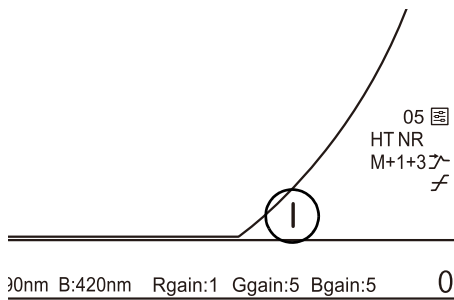

• Full HD mode

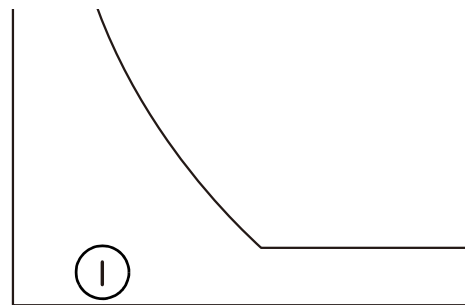

- (2) Enter a comment and press the [Enter] key.
Input of the comment is finalized.

Note

- If you press the [Esc] key before finalizing, the input is canceled and the procedure name before the change is displayed.

7.17.2 Starting/Stopping the Timer

This section describes the method of starting/stopping the timer on the observation screen.

Note

- When the “Timer” function is assigned to the Multi button, the timer function can be operated by using the Multi button on the front panel.

Starting the timer

The timer starts and it appears on the observation screen.

Keyboard	Press the [Timer] key.
Front panel	Press the Multi button to which the timer function is assigned.

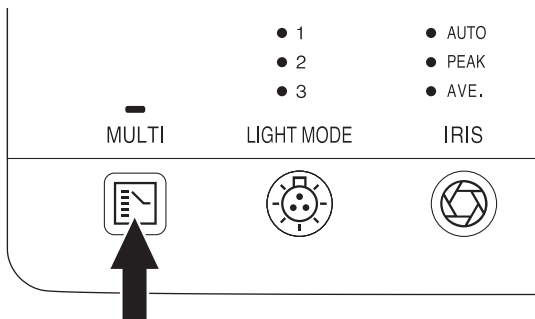
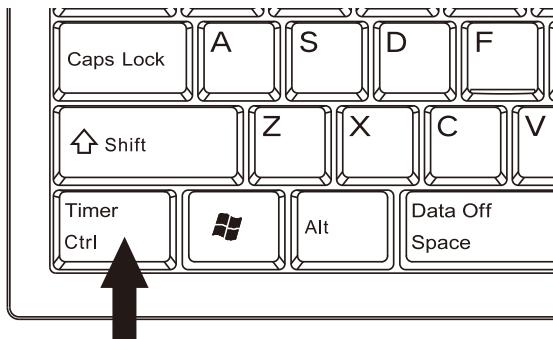

Stopping the timer

The timer stops.

Keyboard	Press the [Timer] key.
Front panel	Press the Multi button to which the timer function is assigned.



Resetting the timer

Keyboard	Press the [Timer] key while pressing the [Shift] key.
Front panel	Press and hold the Multi button to which the timer function is assigned for about two seconds.

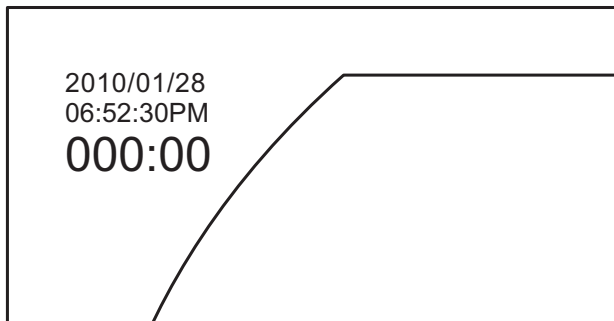

Clearing the display

After stopping the timer, repeat the reset operation twice.

7.17.3 Lap Time Function

The lap time can be displayed on the observation screen.

➔ For details on how to set the lap time function, see “5.5.5 Lap Time Display”.

Note

- The lap time can be displayed only when the screen resolution setting is Full HD.

- (1) Press the button to which the lap time function was assigned. The lap time starts and is displayed on the observation screen. When the button is pressed for the first time, the “L1” lap time starts.

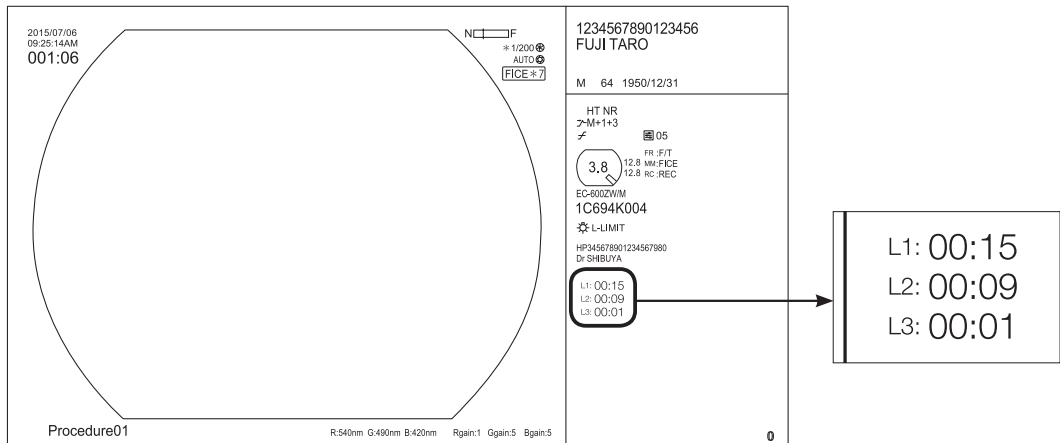

- (2) The Lap Time Display appears as follows each time the button to which the lap time function was assigned is pressed.

- 1st time: “L1” starts.
- 2nd time: “L1” stops and “L2” starts.
- 3rd time: “L2” stops and “L3” starts.
- 4th time: “L3” stops.
- 5th time: Returns to the initial state.

Lap Time Display Example

	Initial state	1st time	2nd time	3rd time	4th time
L1:	00 : 00	00 : 01	→ 05 : 21	05 : 21	05 : 21
L2:	00 : 00	00 : 00	00 : 01	→ 03 : 20	03 : 20
L3:	00 : 00	00 : 00	00 : 00	00 : 01	→ 05 : 01
			↑ 5th time		

7.18 Starting the Examination

- (1) Press the Pump button, if necessary to select “H”, “M”, “L”, or off.

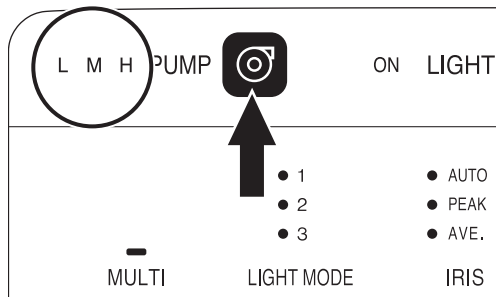

- (2) Press the EXAM. button.

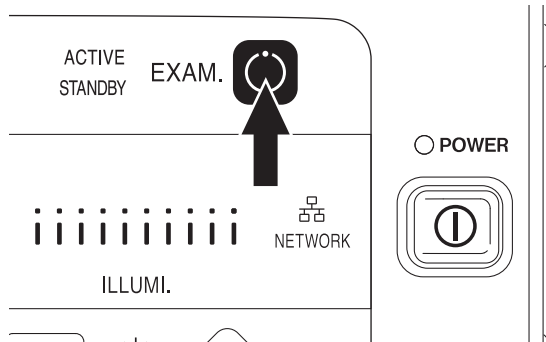

- (3) Insert the endoscope into the patient's body.

7.19 Finishing the Examination

CAUTION

- Immediately after removing the scope connector from the light source, do not touch the light guide prong with your hands since it may be extremely hot. There is a risk of burns. Do not touch the tip of the light guide prong until it has cooled (approximately 5 minutes).

7.19.1 Finishing the First Examination

- (1) Remove the endoscope from the patient.
- (2) Press and hold the EXAM. button for about 2 seconds. "STANDBY" flashes orange, and the light turns off.

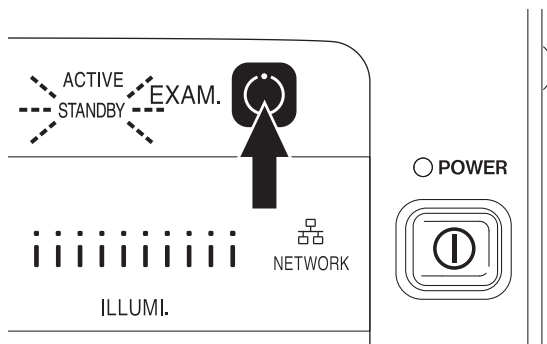

- (3) "STANDBY" lights solid orange. Remove the endoscope.

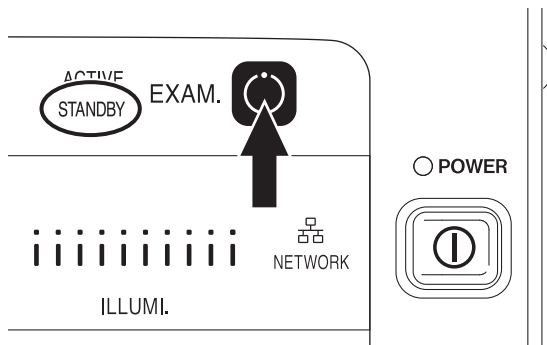

- (4) Clean the endoscope.

Note

- For the cleaning procedure, refer to the operation manual of the endoscope.

7.19.2 Starting the Second Examination or Later

- (1) Install the endoscope on this product.

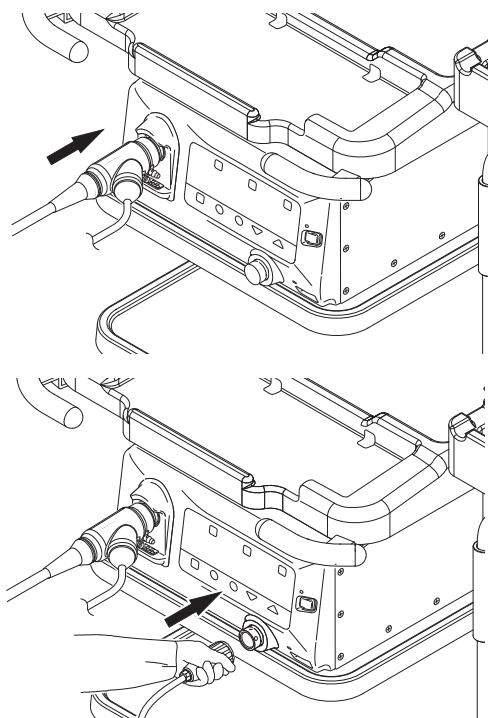

- (2) Press the EXAM. button. "ACTIVE" flashes, and then lights blue.

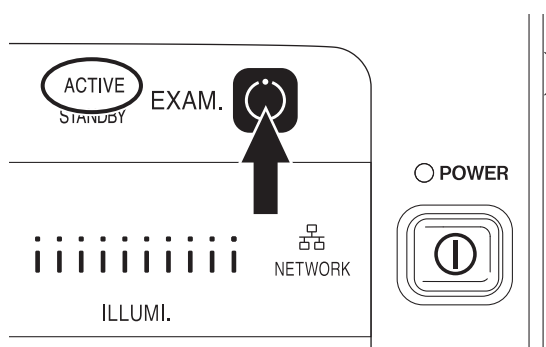

- (3) Press the Light button to turn on the light.

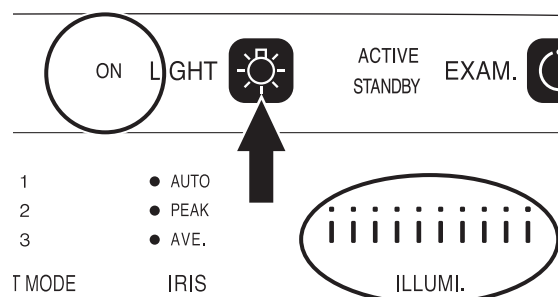

- (4) As in the first time, perform the examination.

7.19.3 Finishing All Examinations

When all examinations have been completed, withdraw the endoscope and turn off the power to this product and the cart. Remove the endoscope and clean it.

Note

- Immediately after the examinations, the processor may be still accessing the network. Make sure that the network access indicator lamp stops flashing before turning off the power.
- Keep the power to the peripherals always ON in normal use. Use the switch on the cart to turn the power ON/OFF.

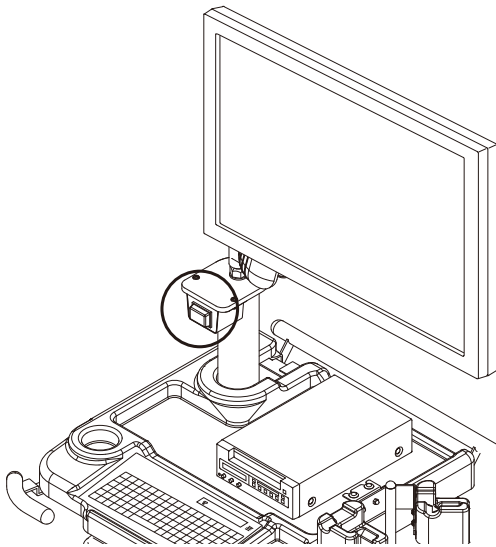

7.20 How to Use EW1 System Software

Operate the EW1 System Software as per instructions provided in the operation manual of the EW1 System Software.

CAUTION

- On the monitor connected to the equipment (EX-WS) with EW1 System Software, an indication is displayed, showing that the image is displayed via the EW1 System Software. For details on the indication, refer to the operation manual of the EW1 System Software.

With this product, images can be printed by a color printer (remote or RS-232C system) or a digital printer and recorded to a video recorder. Prior to use, make sure that images can be printed and recorded normally.

Note

- Since the display characteristics are different between the color printer and the monitor, images printed with the color printer and those displayed on the monitor may differ in color.

8.1 Method of Controlling the Color Printer

There are two ways to control the color printer. One is the remote control method from the remote connector on the printer, and other is the communication to control from RS-232C connector. Because the remote system is controlled directly from this product, there are no troublesome settings, and data transfer is also not necessary. Printer settings must be configured by this product for the RS-232C system, but it can print patient information on the margin of the print paper.

To print the image with the color printer (remote system)

- ➔ “8.2 Printing the Image with the Color Printer (Remote System)”

To print the image with the color printer (RS-232C system)

- ➔ “8.3 Printing the Image with the Color Printer (RS-232C System)”

8.2 Printing the Image with the Color Printer (Remote System)

Images observed on the monitor can be printed on paper by connecting a color printer to this product.

Note

- The processor has two remote terminals (REMOTE 1 and REMOTE 2). Settings for assigning the printer to each remote connector should be performed by service personnel.

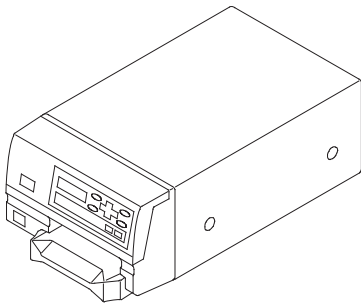

8.2.1 Assignment of Image Capture Switches

The endoscope's scope switches to which "Freeze" and "Trigger" are respectively assigned are available to capture images.

Note

- The foot switch of the processor can be set as switches for capturing images.
- "4.2.7 Endoscope Tab"

8.2.2 Printer Setting

When the remote system is used for connecting the color printer, open the Printer Setup screen from the Peripheral Setup screen and then select "Not used" for "Usage".

→ "5.4.3 Printer Tab"

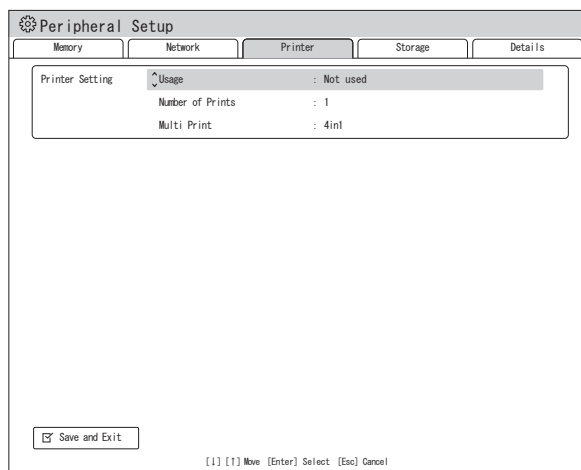

8.2.3 Capturing the Image

Captures the image onto the printer unit.

<Capture the image by using the scope switch of the Endoscope>

- (1) Focus the object to be recorded on the screen, and freeze the image by pressing the scope switch to which “Freeze” is assigned.

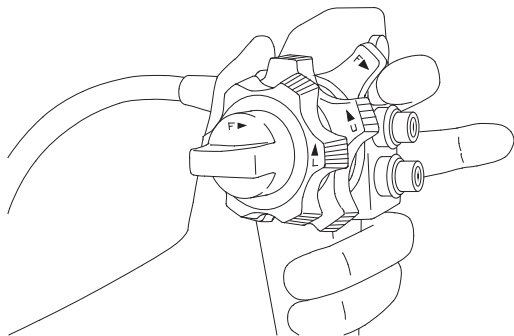

Note

- The observation screen is frozen while the scope switch to which the Freeze function is assigned is pressed. While the screen is frozen, the video image is displayed in the sub-screen. When Mask Type: Type 1 is selected in SXGA mode, each pressing of the [Tab] key changes the display position of the sub-screen in order of the upper left → upper right → lower right → lower left.

→ “3.9 Data Display on the Observation Screen”

- (2) While the image is static, pressing the scope switch to which “Trigger” is assigned captures the image.

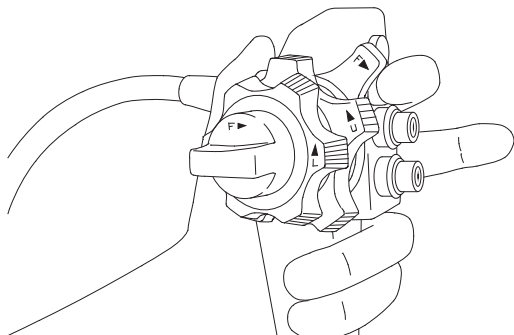

→ “4.2.7 Endoscope Tab”

<Capture the image by using the foot switch>

Note

- How to set the foot switch directly connected to the printer varies depending on the devices. For details, refer to the instruction manual for each printer.

- (1) Focus the object to be recorded on the screen, and freeze the image by pressing the scope switch to which “Freeze” is assigned.

Note

- The observation screen is frozen while the scope switch to which the Freeze function is assigned is pressed. While the screen is frozen, the video image is displayed in the sub-screen. When Mask Type: Type 1 is selected in SXGA mode, each pressing of the [Tab] key changes the display position of the sub-screen in order of the upper left → upper right → lower right → lower left.

→ “3.9 Data Display on the Observation Screen”

- (2) When you step on the foot switch while the image is static, the image is captured to the printer.

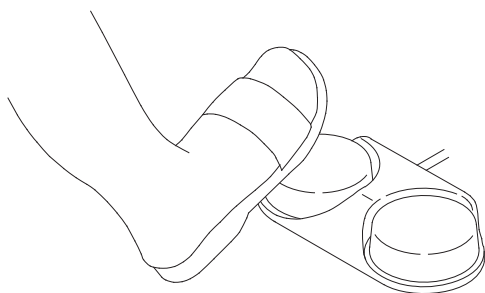

<Capture the image by using remote controller>

- (1) Focus the object to be recorded on the screen, and freeze the image by pressing the scope switch to which “Freeze” is assigned.

Note

- The observation screen is frozen while the scope switch to which the Freeze function is assigned is pressed. While the screen is frozen, the video image is displayed in the sub-screen. When Mask Type: Type 1 is selected in SXGA mode, each pressing of the [Tab] key changes the display position of the sub-screen in order of the upper left → upper right → lower right → lower left.

→ “3.9 Data Display on the Observation Screen”

- (2) While the image is static, pressing the CAPTURE button on the remote controller captures the image.

Note

- The name of the button on the remote controller varies depending on the devices. For details, refer to the instruction manual for each printer.

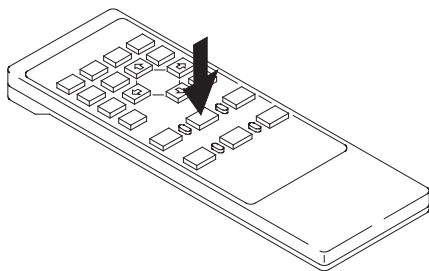

8.2.4 Printing the Image

The captured image can be printed.

When the print button on the printer unit or on the remote controller is pressed, the image is printed out.

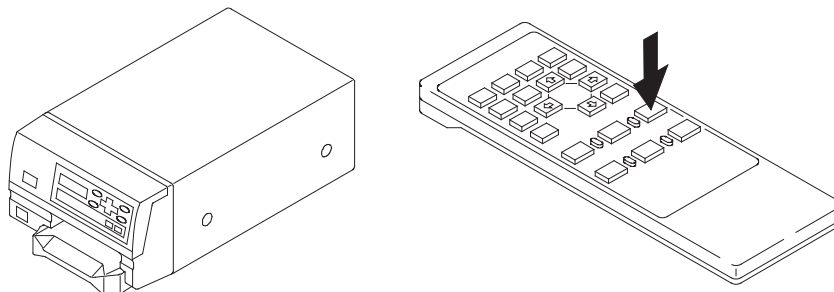

8.3 Printing the Image with the Color Printer (RS-232C System)

Images observed on the monitor can be printed on paper by connecting a color printer to this product.

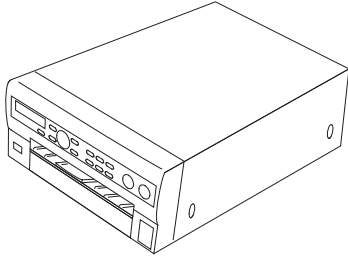

Full screen or multiple screen images (four images, etc.) can be printed on a single sheet of printout paper.

➔ “5.4.3 Printer Tab”

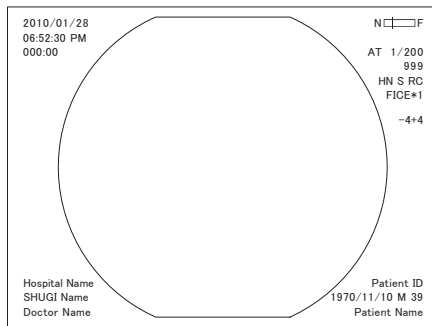

Full screen

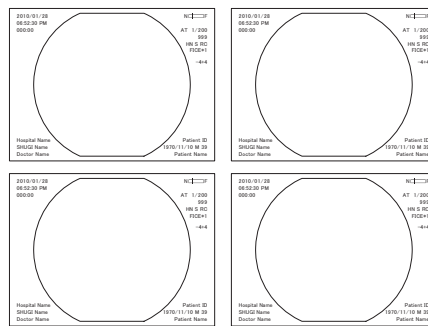

4 images

The patient name, date and time can be printed at the margin of the print paper. With the remote system, the patient name, date and time are not printed.

➔ “5.2.1 Registering Patient Information”

Note

- When registering patient information or switching to new patient information, patient information is sent to the printer. While patient information is sent to the printer (for about 30 seconds), images cannot be captured. In addition, when patient information is sent, the image already loaded in the printer is printed forcibly.
- If the message “Preparation for printing is in progress” appears while loading an image, the image is not loaded into the printer. If this happens, wait until the message disappears and then load the image again.

8.3.1 Assignment of Image Capture Switches

The endoscope's scope switches to which "Freeze" and "Trigger" are respectively assigned are available to capture images.

Note

- The foot switch of the processor can be set as switches for capturing images.
- Settings for assigning the image capture switches should be performed at the time of installation.

→ "4.2.7 Endoscope Tab"

8.3.2 Printer Setting

Note

- The printer to be used needs to be registered in advance. Registration of the printer is performed by our service personnel.

To register the printer to be used, the model name of the printer, the number of prints and the number of images on a single sheet of printer paper are specified. Depending on the printer models, some settings are fixed and cannot be changed.

→ "5.4.3 Printer Tab"

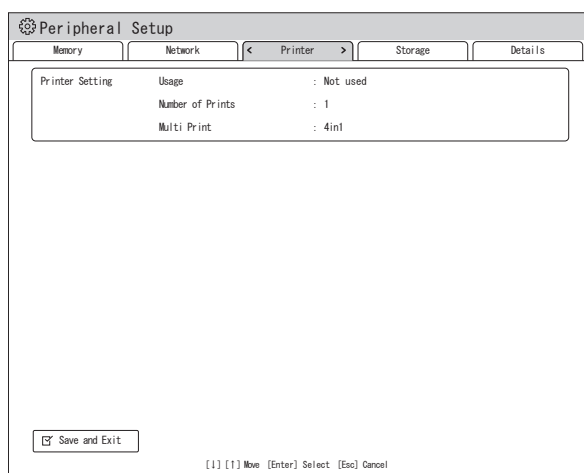

8.3.3 Capturing the Image

Captures the image onto the printer unit.

Note

- If the "Preparation for printing is in progress" appears while capturing an image, the image is not captured into the printer. Wait until the message disappears and then try again.

<Capturing the image by using the scope switch of the endoscope>

- (1) Focus the object to be recorded on the screen, and freeze the image by pressing the scope switch to which "Freeze" is assigned.

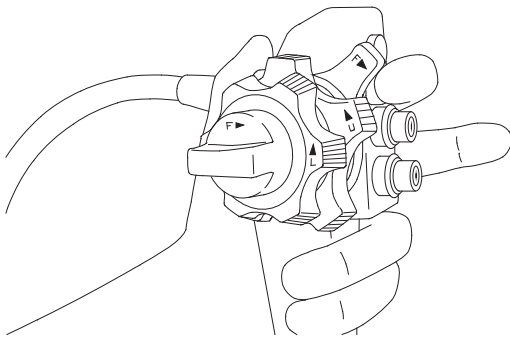

Note

- The observation screen is frozen while the scope switch to which the Freeze function is assigned is pressed. While the screen is frozen, the video image is displayed in the sub-screen. When Mask Type: Type 1 is selected in SXGA mode, each pressing of the [Tab] key changes the display position of the sub-screen in order of the upper left → upper right → lower right → lower left.

→ “3.9 Data Display on the Observation Screen”

- (2) While the image is static, pressing the scope switch to which “Trigger” is assigned captures the image.

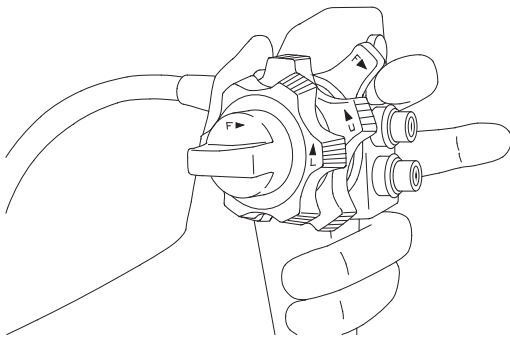

→ “4.2.7 Endoscope Tab”

8.3.4 Printing the Image

Prints the captured image.

The print operation method differs depending on the print mode set.

In the Auto mode, when the number of images captured reaches the number of images that has been set, the images are automatically printed out.

In the Manual mode, images are printed out when the print button on the printer unit or on the remote controller is pressed.

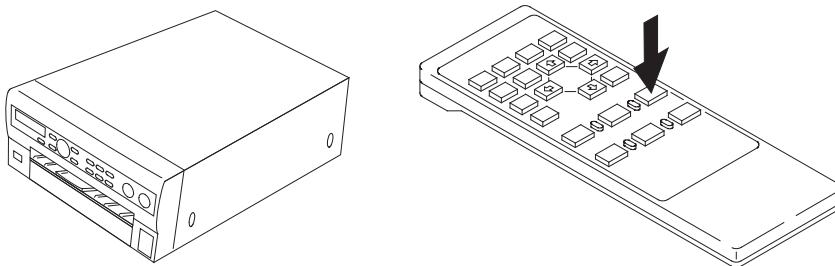

8.4 Printing the Image with the Digital Printer

Images observed on the monitor can be printed on paper by connecting a digital printer to this product.

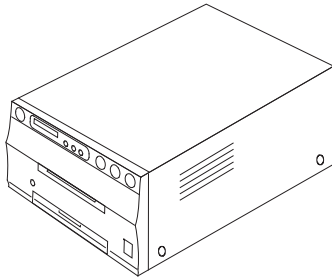

Full screen or multiple screen images (four images, etc.) can be printed on a single sheet of printout paper.

→ “5.4.3 Printer Tab”

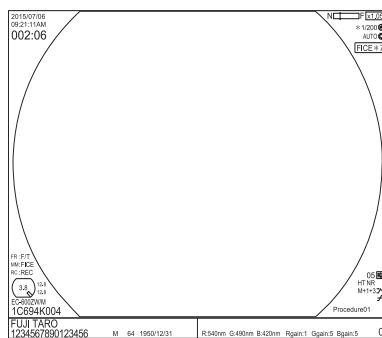

Full screen

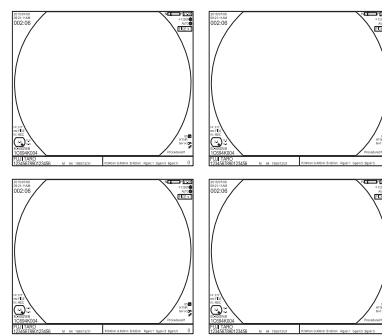

4 images

The patient name, date and time can be printed at the margin of the print paper.

→ “5.2.1 Registering Patient Information”

Note

- When registering patient information or switching to new patient information, patient information is sent to the printer. While patient information is sent to the printer (for about 30 seconds), images cannot be captured. In addition, when patient information is sent, the image already loaded in the printer is printed forcibly.

8.4.1 Assignment of Image Capture Switches

The endoscope's scope switches to which “Freeze” and “Trigger” are respectively assigned are available to capture images.

Note

- The foot switch of the processor can be set as switches for capturing images.
- Settings for assigning the image capture switches should be performed by service personnel at the time of installation.

→ “4.2.7 Endoscope Tab”

8.4.2 Printer Setting

Note

- The printer to be used needs to be installed in advance. Installation of the printer should be performed by service personnel.

To register the printer to be used, the model name of the printer, the number of prints and the number of images on a single sheet of printer paper are specified. Depending on the printer models, some settings are fixed and cannot be changed.

→ “5.4.3 Printer Tab”

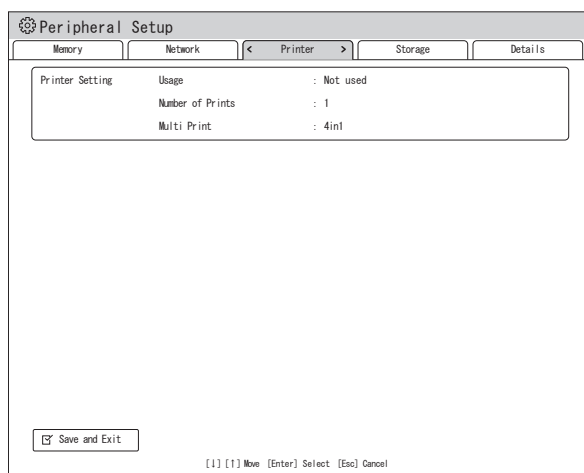

8.4.3 Capturing the Image

Captures the image and loads it onto the printer unit.

<Capturing the image by using the scope switch of the Endoscope>

- (1) Focus the object to be recorded on the screen, and freeze the image by pressing the scope switch to which “Freeze” is assigned.

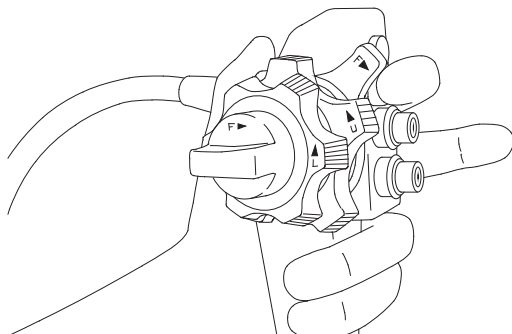

Note

- The observation screen is frozen while the scope switch to which the Freeze function is assigned is pressed. While the screen is frozen, the video image is displayed in the sub-screen. When Mask Type: Type 1 is selected in SXGA mode, each pressing of the [Tab] key changes the display position of the sub-screen in order of the upper left → upper right → lower right → lower left.

→ “3.9 Data Display on the Observation Screen”

- (2) While the image is static, pressing the FR switch captures the image.

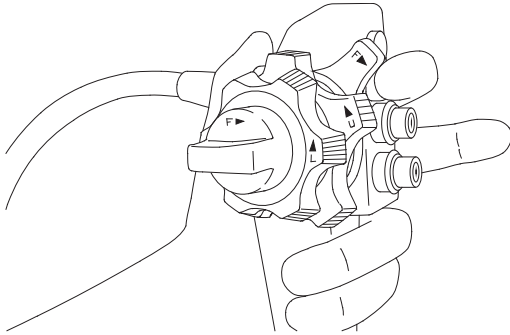

→ “4.2.7 Endoscope Tab”

8.4.4 Print Mode Setting

In the digital printer, the print operation method is set according to the print mode. The print mode is selected from the two types of modes: “Auto” and “Manual.” Taking, as an example, how images are captured with four images printed out onto a print sheet, this section describes these modes.

Note

- Print mode setting should be performed by service personnel at the time of installation.

<Auto Mode>

After the images have been captured in order from image 1 to image 4, the images are automatically printed out. When the images are completely printed out, the system returns to image 1, erases the previous image, and then captures an image to it.

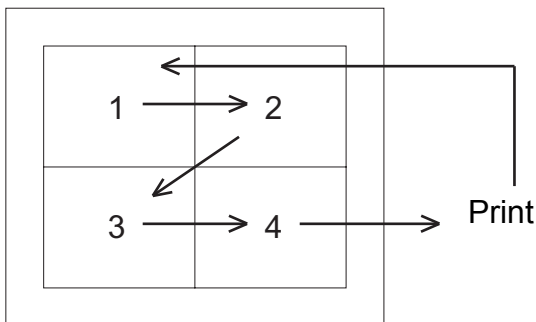

<Manual Mode>

Select an image to be printed out from the thumbnail display screen, and then print it out.

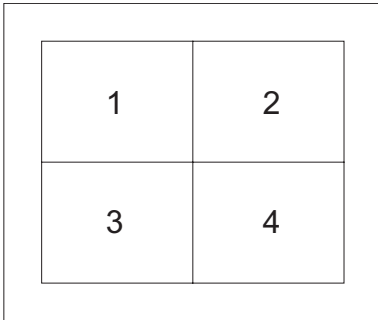

Before printing an image, the preview screen is available for confirmation.

To print captured images, refer to the following section.

➔ “8.9.4 Printing Searched Images (only for digital printer)”

8.5 Recording Video Images on the Video Recorder (by Operating the Buttons)

When the video recorder HVO-3300MT (SONY) / HVO-1000MD (SONY) / HVO-550MD (SONY) connected, you can record the image focused on the endoscope.

→ “4.1.7 Installation for System Expansion”



Note

- Do not connect HVO-3300MT or HVO-1000MD to the RGB TV connector.

→ “Operation Manual of HVO-3300MT”

→ “Operation Manual of HVO-1000MD”

8.5.1 Recording Video Images by Operating the Buttons on the Video Recorder

- (1) Press the OPEN/CLOSE  button. The tray opens.
- (2) Place a DVD on the tray.
- (3) Press the OPEN/CLOSE  button. The tray closes.

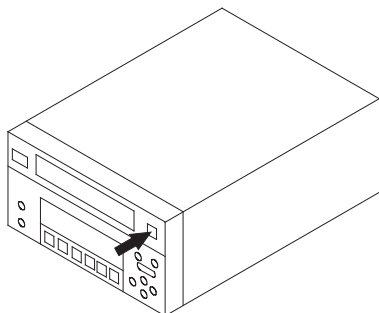

- (4) To start recording video images, press the REC button on the video recorder.

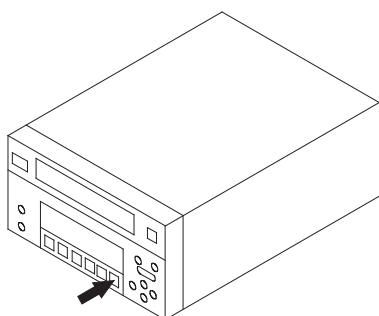

- (5) To stop recording video images, press the STOP button.

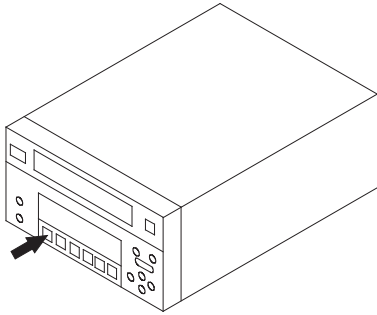

- (6) To start recording video images again, repeat Steps (4) and (5).

- (7) To remove the DVD, press the OPEN/CLOSE \triangle button.

Note

- How to operate the device varies depending on the video recorders. For details, refer to the instruction manual for each video recorder.

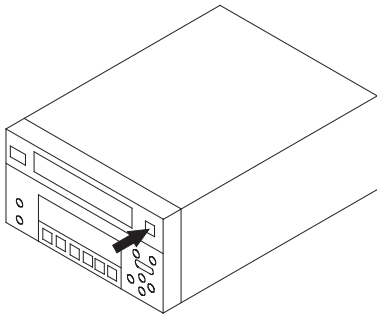

8.6 Recording Video Images on the Video Recorder (by Operating the Scope Switch)

8.6.1 Assignment of Video Recording Switches

Video images are recorded by using the scope switch on the endoscope to which the “Trigger” function is assigned.

Note

- The “Trigger” function needs to be assigned to a scope switch. The setting is performed by service personnel.

→ “4.2.7 Endoscope Tab”

8.6.2 Starting Video Recording

Press the scope switch to which “Trigger” is assigned to start video recording. Press the scope switch again to pause video recording.

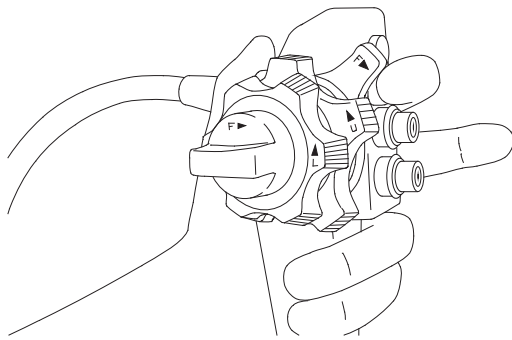

→ “4.2.7 Endoscope Tab”

8.7 How to Record/Print Images on the Internal and External Storage Devices

Images can be saved to the internal storage device of this product. Images stored in the internal storage can be copied to an external storage device.

→ “5.4.2 Memory Tab”

8.7.1 Internal Storage Device

This product has an internal storage device. The internal storage device is used for storing exam images and for backing up exam images when the network transfer is enabled. After an examination is over, images are copied to an external storage device, or are sent to the image server or the digital printer.

The maximum number of recordable images and examinations is as follows.

		Maximum number of recordable images (for all examinations)	Maximum number of recordable images (for each examination)	Standard number of recordable examinations (100 images / examination)	Minimum number or recordable examinations (Maximum / examination)
Compression rate	JPEG (1/20)	21,690	800	216	27
	JPEG (1/10)	16,270	750	165	21
	JPEG (1/5)	5,910	500	59	11
	TIFF	840	130	8	6

Note

- The number of recordable images varies depending on the type of image.
- Even if the screen is displayed in Full HD on a Full HD monitor, images are stored in the SXGA format.

The system checks the free space of the internal storage device when starting or terminating an examination. If the space in the internal storage device is not sufficient for the next examination, the system deletes all image data of an examination already copied to an external storage device or those already transferred to the network in chronological order.

When the internal storage device is filled with image data not yet copied to an external storage device or those not yet transferred to the image server, if the space in the internal storage device is not sufficient for the next examination, the message instructing the user to secure the free space is displayed. If this happens, copy the image data to an external storage device or transfer them to the image server to secure the free space in the internal storage device.

→ “8.8 Copying Images to External Storage Device”

→ “8.9.2 Transferring Searched Images”

Note

- If there are images that are not yet transferred, the network or image server may be faulty. Be sure that the network is connected properly, hubs and routers operate normally and the image server is operating properly, and then try image transfer again to check whether or not images are properly recorded onto the server.
- If images that are not yet copied or transferred are not necessary, those images can be deleted by retrieving them or by initializing the internal storage device. Before deleting the image, be sure that all images are not necessary.

→ “8.9.3 Deleting Searched Images”

→ “5.4.2 Memory Tab”

If the free space in the internal storage device is insufficient at the time of starting an examination, the message asking whether or not the examination is continued is displayed.

When “No” is selected: Operation returns to the stand-by state.

When “Yes” is selected: The examination is performed without recording images in the internal storage device. When the network is used, images are not backed up but are transferred to the image server.

Note

- If there is no alternative to the image storage function (such as a printer or external filing device), select “No” to end the examination, secure the free space for image storage and then start the examination again.

8.7.2 Assignment of Image Capture Switches

The endoscope's scope switches to which “Freeze” and “Trigger” are respectively assigned are available to capture images.

Note

- The foot switch of the processor can be set as switches for capturing images.
- Settings for assigning the image capture switches should be performed by service personnel at the time of installation.

→ “4.2.7 Endoscope Tab”

8.7.3 Capturing the Image to Internal Storage Device

Captures the image to the internal storage device.

Note

- When images are captured with FICE turned ON, two images, FICE and normal images, are captured to the internal storage device in a single operation.

<Capturing the image by using the scope switch of the Endoscope>

- (1) Focus the object to be recorded on the screen, and freeze the image by pressing the scope switch to which “Freeze” is assigned.

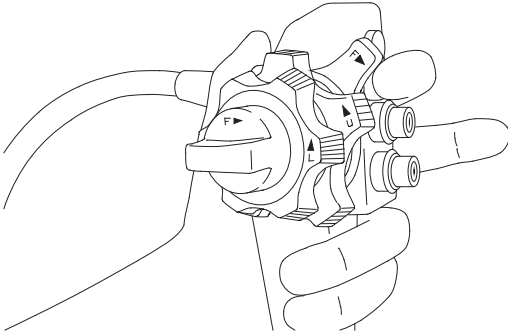

Note

- The observation screen is frozen while the scope switch to which the Freeze function is assigned is pressed. While the screen is frozen, the video image is displayed in the sub-screen. When Mask Type: Type 1 is selected in SXGA mode, each pressing of the [Tab] key changes the display position of the sub-screen in order of the upper left → upper right → lower right → lower left.

→ “3.9 Data Display on the Observation Screen”

- (2) While the image is static, pressing the scope switch to which “Trigger” is assigned captures the image.

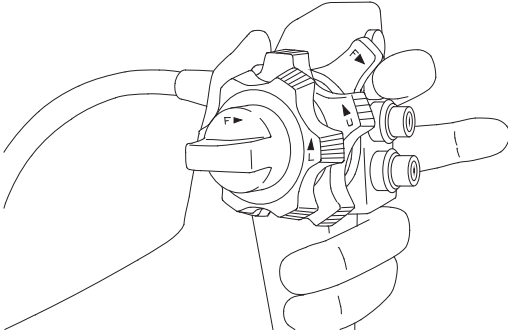

→ “4.2.7 Endoscope Tab”

8.8 Copying Images to External Storage Device

Images stored in the internal storage device can be copied to an external storage device.

8.8.1 External Storage Device

Use the following external storage device.

External storage device: Swissbit external storage device (SFU22048E1BP2TO-I-MS-111-STD or SFU22048E3BP2TO-I-MS-121-STD)

For other external storage devices, consult your local FUJIFILM dealer.

If images cannot be saved in an external storage device that still has free space, format the external storage device to FAT (FAT32) on a personal computer (Windows) or use a new external storage device.

FAT is a system for managing data saved in the hard disk, CF memory card, etc. With FAT16, a maximum of 2GB of data can be managed. With FAT32, a maximum of 2048GB (2TB) of data can be managed.

Format the external storage device to FAT32.

→ “5.4.2 Memory Tab”

Note

- Do not remove the external storage device while data writing to an external storage device is in progress. If removed, the processor may not operate properly. If this happens, turn off the processor and then turn it on again.

8.8.2 Copying Images to an External Storage Device

When no examination is in progress, images in the internal storage device can be copied to an external storage device connected to this product. Daily examination data can be copied easily. In addition, the desired images can be copied using the image search function.

Images recorded in the internal storage device during an examination can also be copied to an external storage device automatically (simultaneous recording).

<How to copy daily exam data>

Daily exam data can be copied to an external storage device only by operating the keyboard, without retrieving the images.

Note

- After an examination is started, the date and time of the examination is recorded when the first image is obtained. If the examination was started on the previous day, the image data cannot be copied with the following procedure. If this happens, copy the images by retrieving them.

- (1) Prepare an external storage device.

Note

- Back up the data in the external storage device and initialize it with this product or a personal computer to secure a sufficient space for image recording.

- Although a certain free space is secured by deleting unnecessary data, if the free space is insufficient, images cannot be copied. Secure an enough space for image recording.
- When copying image data to an external storage device, if the file of the same name already exists in the external storage device, the data is overwritten. Be sure that there are no images that are edited by a personal computer, etc.

- (2) Make sure that no examination is in progress and connect the external storage device. The memory access lamp lights in green.

Note

- If an examination is in progress, image data cannot be copied.

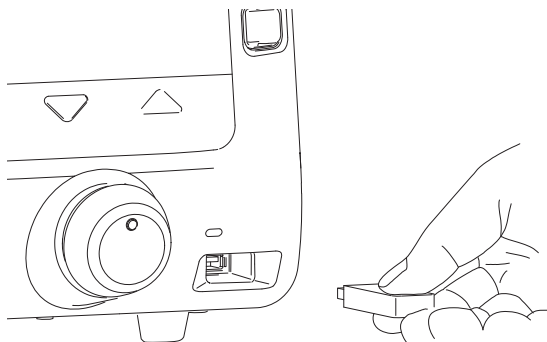

- (3) Press the [Alt] and [C] keys on the keyboard at the same time.
- (4) The message "Today's examination data will be copied. OK?" is displayed. When "Yes" is selected, data copy starts. When data copy is in progress, the memory access lamp flashes orange. When "No" is selected, data copy is not executed.

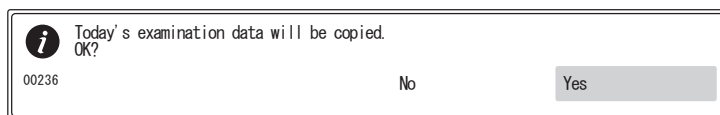

- (5) When data copy is completed and the memory access lamp lights green, the external storage device can be removed. Remove the external storage device and be sure that necessary data is copied by using a personal computer, etc.

Note

- Do not remove the external storage device while the memory access lamp flashes orange. If the external storage device is removed while the memory access lamp flashes in orange, it may damage the data being copied or the external storage device itself.

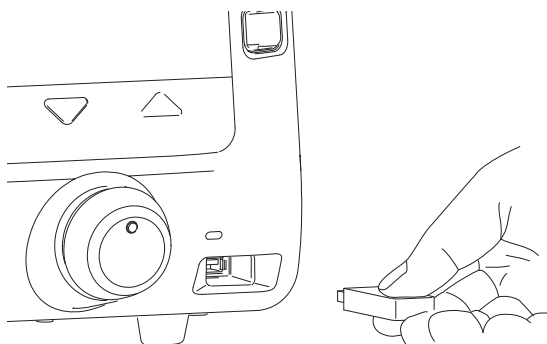

<How to copy images by retrieving them>

- (1) Prepare an external storage device.

Note

- Back up the data in the external storage device and initialize it with this product or a personal computer to secure a sufficient space for image recording.
- Although a certain free space is secured by deleting unnecessary data, if the free space is insufficient, images cannot be copied. Secure an enough space for image recording.
- When copying image data to an external storage device, if the file of the same name already exists in the external storage device, the data is overwritten. Be sure that there are no images that are edited by a personal computer, etc.

- (2) Make sure that no examination is in progress and connect the external storage device. The memory access lamp lights in green.

Note

- If an examination is in progress, image data cannot be copied.

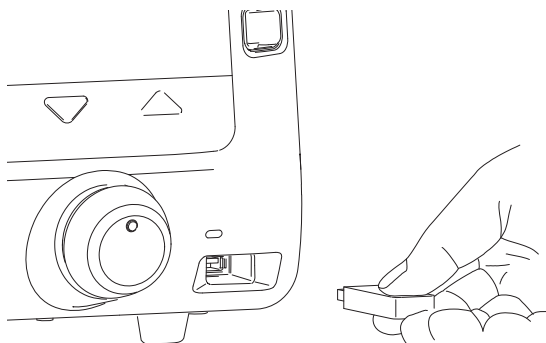

- (3) By following the procedure described in “8.9.1 Searching Images in Internal and External Storage Devices”, display the list of search result. To change the page of the list, move the cursor to “Search Result 1/4 (to 4/4)” and press the [←] or [→] key.
- (4) To copy all exam data in the list, press the [A] key. To copy specific exam data in the list, move the cursor to the desired exam data and press the [C] key.

Search All					
Search Conditions : NA NA					
◀ Search Result 1/1 ▶					
No.	Date of Exam	Patient ID	Patient Name	Exam No.	
01	2014/11/27				
02	2014/11/27				
03	2014/11/27				

◀ Search Result 1/1 ▶ [A] Copy all [C] Copy
 [] [] Move [Enter] Select [Esc] Cancel [N] Transfer [D] Delete

- (5) The confirmation message is displayed. When “Yes” is selected, data copy starts. When data copy is in progress, the LED for the external storage device flashes in orange.

When the [A] key is pressed:

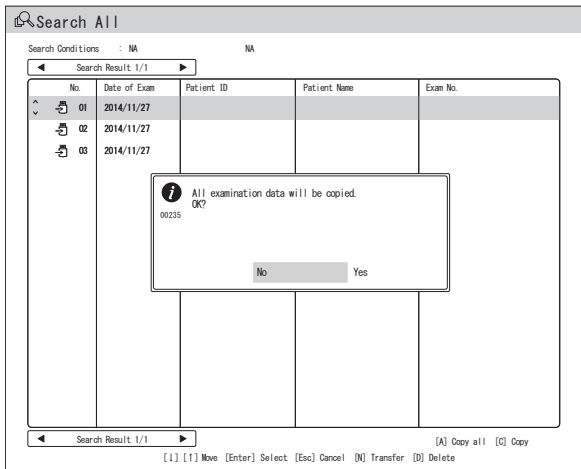

When the [C] key is pressed:

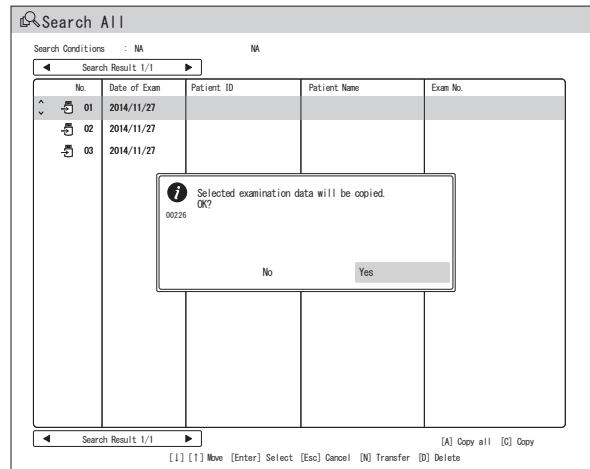

- (6) When data copy is completed and the LED for the external storage device lights in green, the external storage device can be removed. Remove the external storage device and be sure that necessary data is copied by using a personal computer, etc.

Note

- Do not remove the external storage device while the memory access lamp flashes orange. If the external storage device is removed while the memory access lamp flashes in orange, it may damage the data being copied or the external storage device itself.

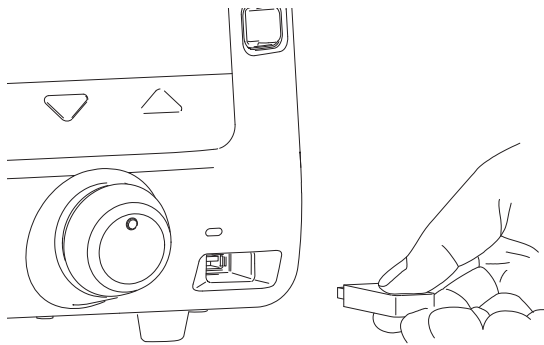

8.8.3 Checking Images on a Personal Computer

<When images are stored in the internal storage device>

Images recorded on the external storage device can be checked on a personal computer capable of reading the external storage device.

When an image is captured, a folder named with the date of shooting is created and a folder named with the time of shooting is also created in the folder.

Captured images are saved in the folder named with the time of shooting. (Example: When shooting starts at 11:20:40 a.m. on December 31st 2013, images are saved in the “\DCIM\20131231\112040” folder.)

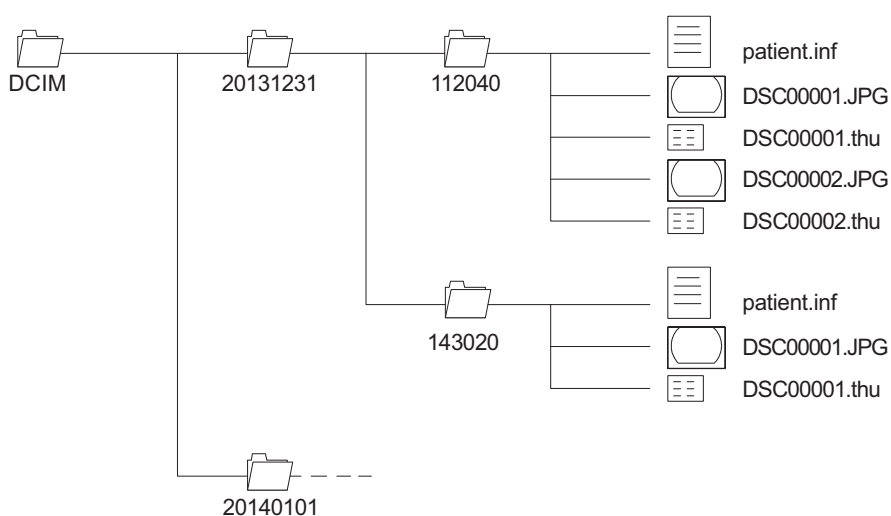

<When images are transferred to the FTP server>

When “ON” is selected for “Auto Copy Mode” on the “Memory” tab in the Image Setup Page screen, the “BACK” folder is created and a folder named with the date of capture and a folder named with the time of capture are also created in the folder. Captured images are saved in the folder named with the time of capture. (Example: When image capture starts at 11:20:40 a.m. on December 31st 2013, images are saved in the “\BACK\20131231\112040” folder.)

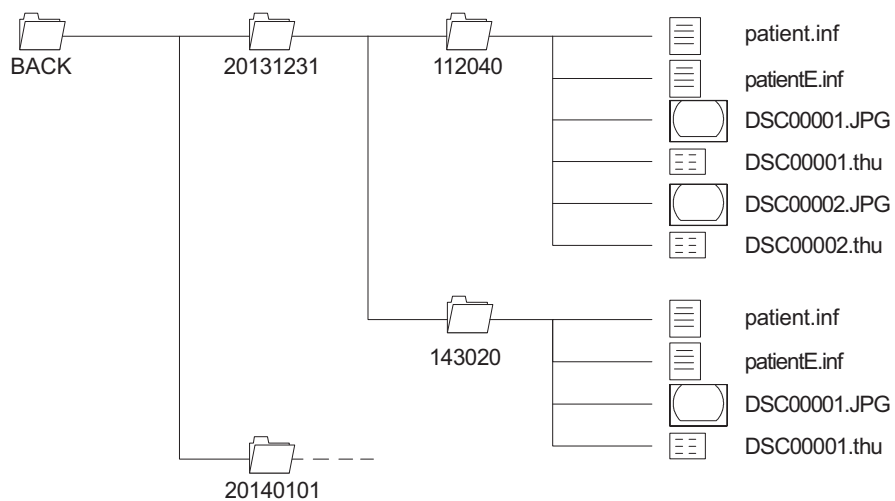
**Note**

- The file extension “.thu” indicates the files of images displayed as thumbnails. (Example: DSC00001.thu)
- The file extension “.inf” indicates the files of patient information. Do not directly edit or overwrite each “.inf” file because it is used when searching images and setting devices.
- Do not directly edit images recorded on the external storage device. To edit an image, copy it into a different area (for example, the hard disk of a personal computer) and edit the copied image. If you directly edit or overwrite an image recorded on the external storage device, the image cannot be displayed on the processor.

8.9 How to Search and Print Images in Internal and External Storage Devices

8.9.1 Searching Images in Internal and External Storage Devices

Images recorded on the internal or external storage device can be narrowed down on the Search screen based on the patient ID and date of inspection and then can be displayed as thumbnails. On the thumbnail display screen, images can be enlarged and printed out.

Note

- The Search screen is not displayed during the operation of the endoscope.
- When thumbnail images are displayed using the search function and then one of the images is enlarged, the enlarged image is also displayed on the monitor connected via RGB TV, Video and S Video connectors.
- When “Used” is selected in “Usage” in the Network Setup screen, images are backed up to the internal storage device. Among the images already backed up, if an image is not yet transferred to the FTP server, (📁) is displayed next to the list number of the image. If the image has already been transferred to the FTP server, (📁) is displayed.
- For image data in an external storage device, (📁) is displayed next to the list number of the image.
- For images already copied, (✓) is displayed next to the list number of the image.

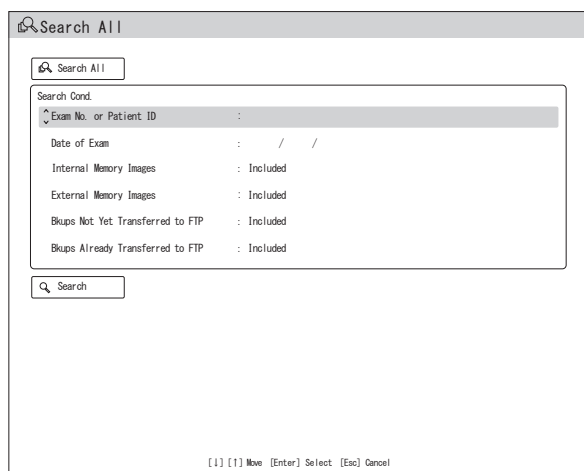

- (1) When “ACTIVE” lights blue, press and hold the EXAM. button for about two seconds. While “STANDBY” is lit orange, press the [Search] key. The search screen appears.

Note

- The contents of the internal or external storage device can be searched when the EXAM. button was pressed and “STANDBY” is orange.

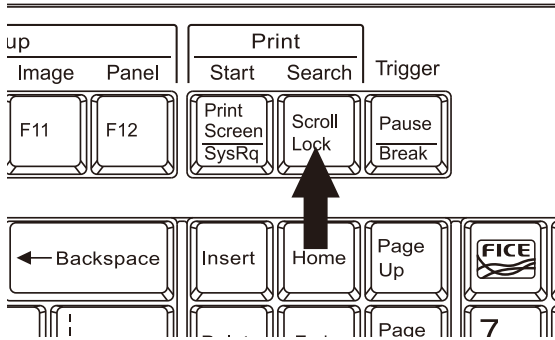

- (2) Set search conditions. When searching with the examination number or patient ID, move the cursor to “Exam No. or Patient ID” and then press the [Enter] key. Character entry is enabled. Enter the examination number or patient ID.

Note

- The patient ID is searched by a search for a match at the beginning of the row.

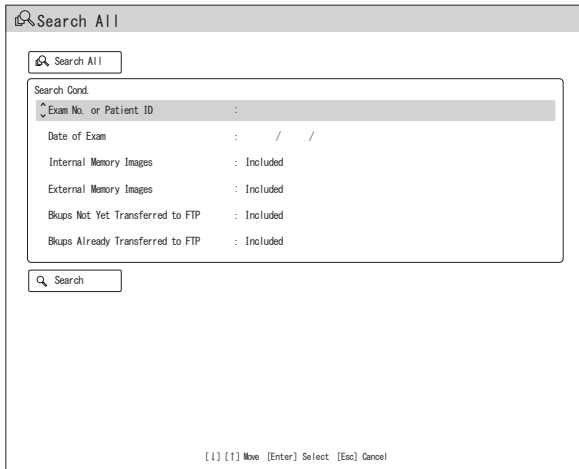

- (3) When searching using the date of examination, move the cursor to “Date of Exam” and press the [Enter] key. Each time the year, month or date is entered and then the [Enter] key is pressed, the next item can be entered.

Search All

Search All

Search Cond.

Exam No. or Patient ID	: 123456
Date of Exam	: / /
Internal Memory Images	: Included
External Memory Images	: Included
Bkups Not Yet Transferred to FTP	: Included
Bkups Already Transferred to FTP	: Included

Search

[] [1] Move [Enter] Select [Esc] Cancel

- (4) Select the image to be searched. Move the cursor to “Internal Memory Images” and press the [Enter] key. In the displayed pop-up menu, select whether or not the images stored in the internal storage device are included and press the [Enter] key. Similarly, specify whether or not “Bkups Not Yet Transferred to FTP” and “Bkups Already Transferred to FTP” are included.

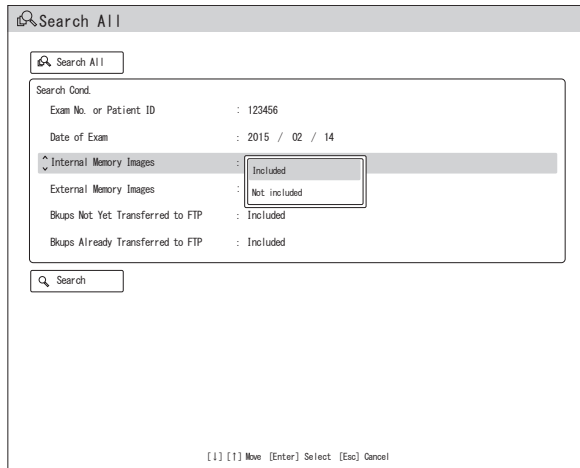

Internal Memory Image:

Image data stored in the internal storage device

→ “5.4.2 Memory Tab”

External Memory Image:

Image data copied from the internal storage device to the external storage device

→ “8.8.2 Copying Images to an External Storage Device”

Bkups Not Yet Transferred to FTP:

Image data stored only in the internal storage device, not in the FTP server, while the internal storage device is placed in the backup mode by selecting “Used” is selected for “Usage” in the Network Setup screen

Bkups Already Transferred to FTP:

Image data already transferred to the FTP server while the internal storage device is placed in the backup mode by selecting “Used” is selected for “Usage” in the Network Setup screen

→ “5.4.4 Details Tab”

- (5) Move the cursor to “Search” and press the [Enter] key.
Search by “Patient ID” and/or “Date of Exam” can be executed.

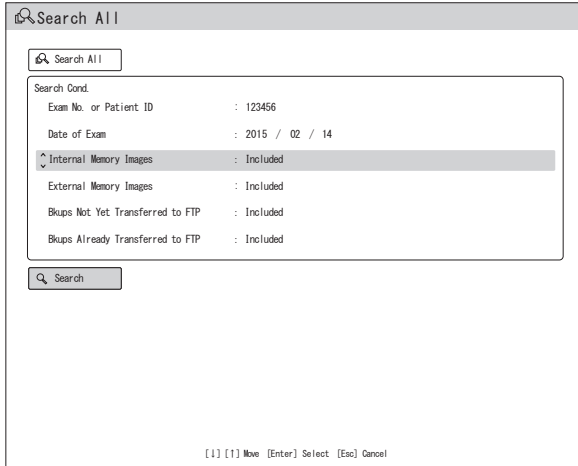

Note

- When listing all images in the internal and external storage devices, move the cursor to “Search All” and press the [Enter] key.

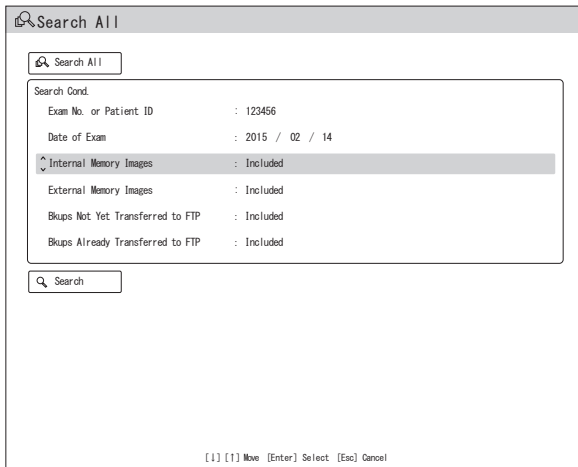

- (6) When the search has finished, search results are listed.
To turn the pages of the list, move the cursor to “Search Result 1/4 (to 4/4)” and press the [←] or [→] key.

Note

- In the list of search results, the latest data is listed at the top.
- A maximum of 1000 images can be listed.
- When “Used” is selected in “Usage” in the Network Setup screen, images are backed up to the internal storage device. Among the images already backed up, if an image is not yet transferred to the FTP server, (📁) is displayed next to the list number of the image. If an image has already been transferred to the FTP server, (📁) is displayed.
- For the images stored in the external storage device, (📁) is displayed next to the list number of the image.

- For images already copied, ☑ is displayed next to the list number of the image.

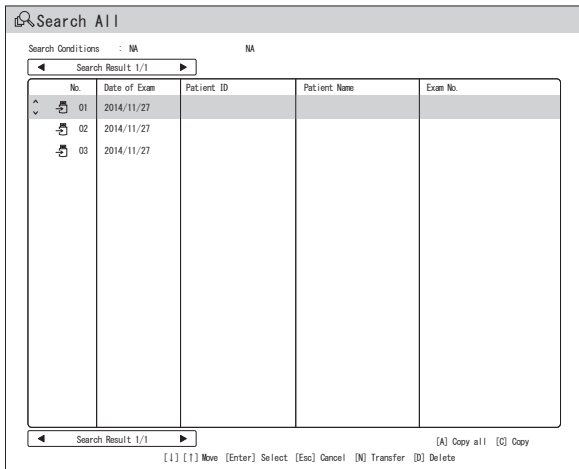

- (7) Move the cursor to the list number of the images to be displayed and press the [Enter] key.

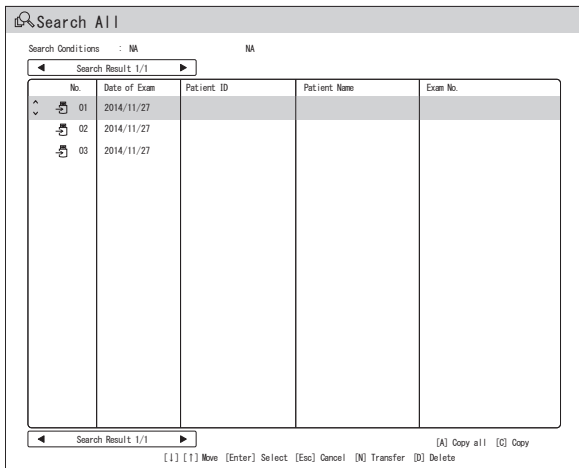

The images of the selected list number are displayed as thumbnails.

Note

- When thumbnail images are displayed using the search function and then one of the images is enlarged, the enlarged image is also displayed on the monitor connected via RGB TV, Video and S Video connectors.

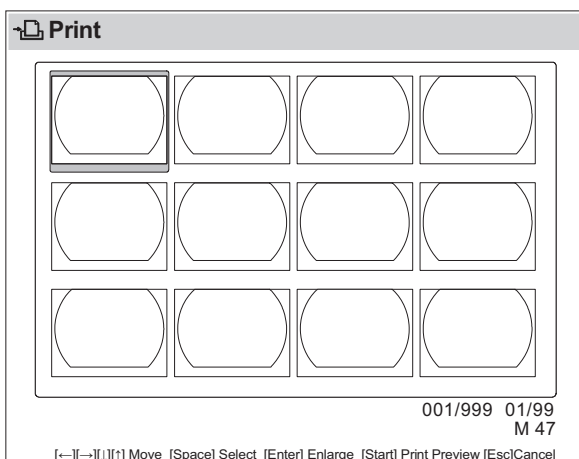

8.9.2 Transferring Searched Images

How to transfer the images searched from the internal and external storage devices is explained below.

- (1) By following the procedure described in “8.9.1 Searching Images in Internal and External Storage Devices”, display the list of search results. To change the page number, move the cursor to “Search Result X/X” (X/X: Current page number/Total number of pages) and press the [←] or [→] key.

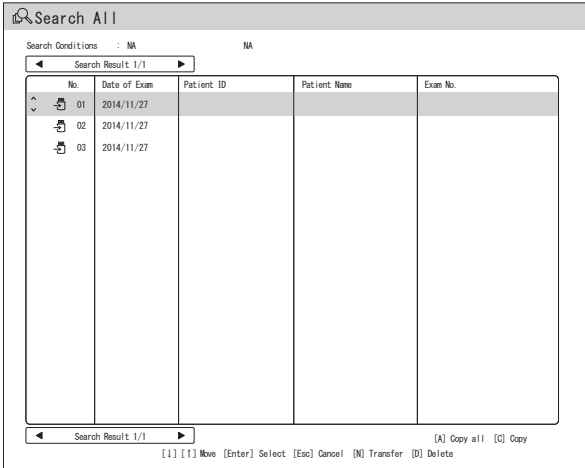

- (2) By using the [↑] or [↓] key, move the list number of the image to be transferred and press the [N] key. The confirmation message “Selected examination data will be transferred to the server. OK?” appears.

When “Yes” is selected, the selected image is transferred.
 When “No” is selected, operation returns to the list of search results.

Note

- When “Not used” is selected for “Usage” in the Network Setup screen, image transfer is not executed even if the [N] key is pressed.

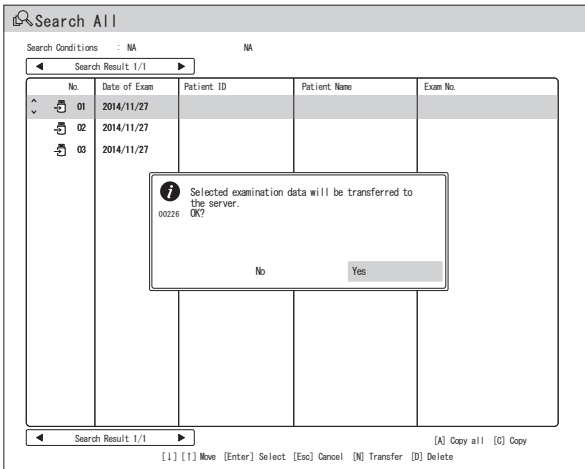

8.9.3 Deleting Searched Images

How to delete the images searched from the internal and external storage devices is explained below.

- (1) By following the procedure described in “8.9.1 Searching Images in Internal and External Storage Devices”, display the list of search results. To change the page number, move the cursor to “Search Result X/X” (X/X: Current page number/Total number of pages) and press the [←] or [→] key.

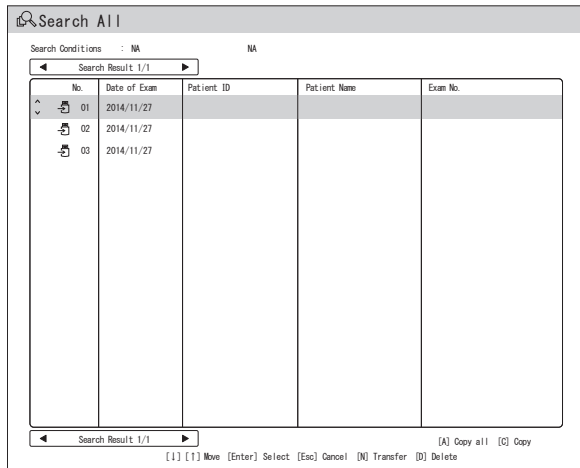

- (2) By using the [↑] or [↓] key, move the list number of the image to be deleted and press the [D] key. The confirmation message “Selected examination data will be deleted. OK?” appears. When “Yes” is selected, the selected image is deleted. When “No” is selected, operation returns to the list of search results.

Note

- Deleted examination data is grayed out. When the [↑] and [↓] keys are pressed, grayed out items are skipped and cannot be selected.
- With this operation, the selected examination data is deleted. However, its list number remains in the search result. To delete it from the list, press the [Esc] key to return to the observation screen and then search again.

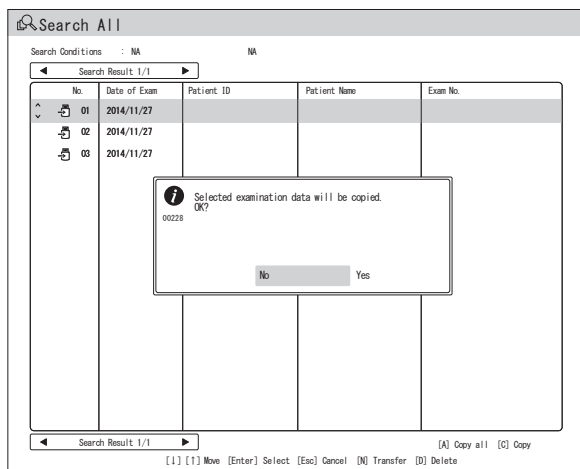

8.9.4 Printing Searched Images (only for digital printer)

This section explains how to print the image searched from the internal and external storage devices by using the search function.

Images searched and displayed from internal and external storage devices can be printed by a digital printer. For details on printer settings, refer to “5.4.3 Printer Tab”.

- (1) Display thumbnail images by following the procedure described in “8.9.1 Searching Images in Internal and External Storage Devices”.
- (2) Select the desired image by pressing the [←], [→], [↑] or [↓] key. The selected box is indicated with a box cursor.
When the [↓] key is pressed with the box cursor placed at the bottom line, the display changes to the next page.

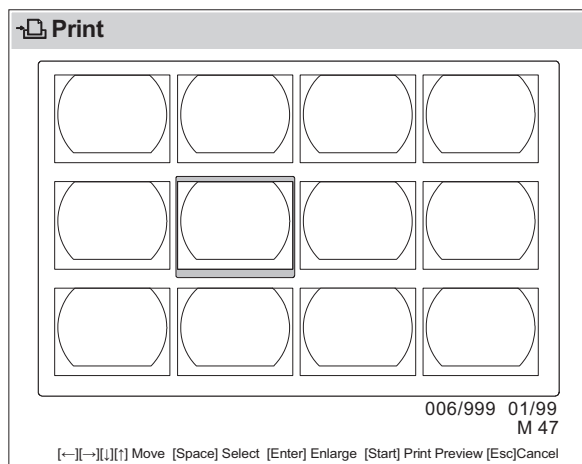

- (3) Move the box cursor to the image to be printed and then press the [Space] key. A “P” mark is displayed on the selected screen. When the [Space] key is pressed again, the “P” mark disappears. When the [Enter] key is pressed, the selected image is enlarged.

Note

- When thumbnail images are displayed using the search function and then one of the images is enlarged, the enlarged image is also displayed on the monitor connected via RGB TV, Video and S Video connectors.

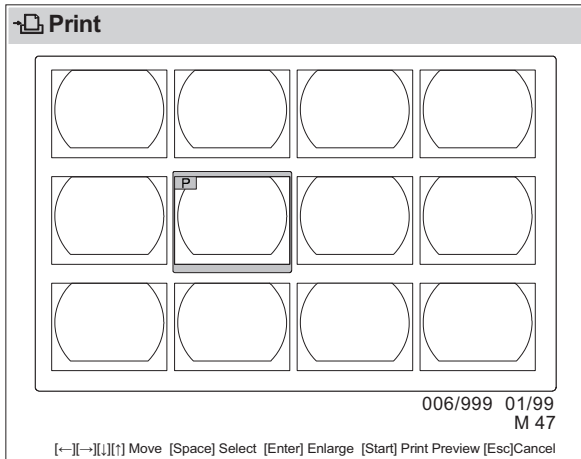

- (4) Repeat Steps (2) and (3) until the “P” mark is displayed for all the images to be printed. Press the [Start] key. The print preview screen appears.

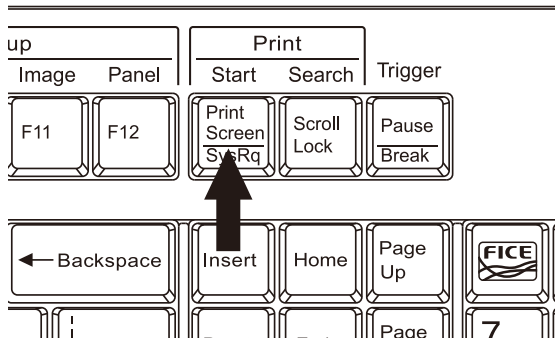

- (5) By pressing the [←] and [→] keys, scroll all pages to check all preview images. The type of preview display varies depending on the settings on the printer.

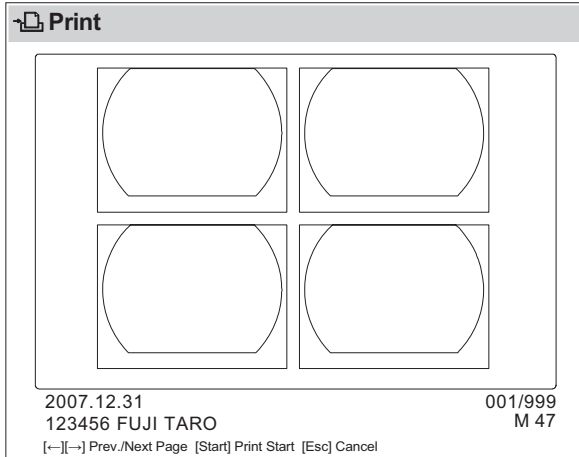

Note

- The “P” marks are numbered such as “P1” and “P2” in the order selected. In the preview screen, the selected images are displayed in order from “P1”.

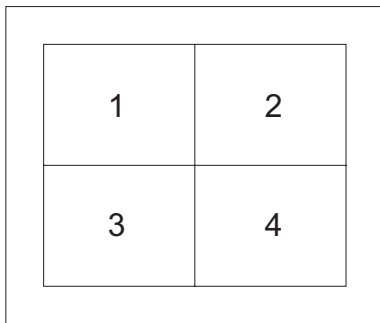

- (6) Press the [Start] key. All images in the print preview screen are printed.

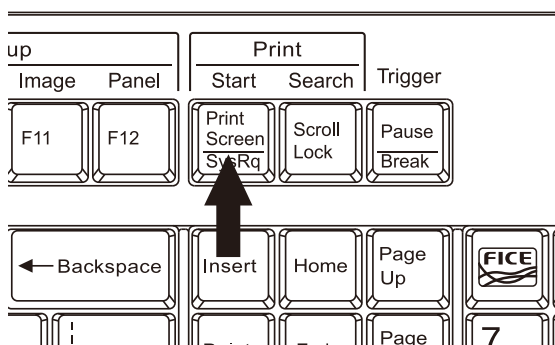

Wear personal protective equipment (such as goggles, facemask, chemical-resistant and waterproof gloves, protective clothing, cap and shoe covers) when performing maintenance of this product.

9.1 Care after Use of Processor

After use or while not in use, remove any debris that is found adhering to this product.

CAUTION

- Do not disassemble or modify this product. Otherwise, the radiant intensity may exceed Class I specifications.
- Clean the equipment in the proper way as specified. Otherwise, the equipment may be damaged.
- Do not spill water or disinfectants on the equipment body. Do not perform disinfection and sterilization by immersing the equipment in chemical liquid or by gas. The equipment may be damaged.
- Do not touch electric contact points directly by hand. Do not wipe contact points any other liquid than alcohol. Doing so may cause corrosion.
- Do not clean the inner side of the scope connector socket or receiving window. If these areas become dusty or dirty, consult your local FUJIFILM dealer. For details on the cleaning, maintenance, and disinfection of the endoscope, refer to the operation manual of the endoscope.

- (1) Turn off the processor.
- (2) Gently wipe off dust, dirt or foreign matter with clean lint-free gauze, etc.
- (3) If any dirt or foreign matter is still present, wipe it off with clean lint-free gauze, etc. moistened with medical-grade neutral detergent.

Note

- Use detergent according to the detergent manufacturer's instructions.
- (4) Wipe the surface with clean lint-free gauze, etc. moistened with 70% ethanol.
 - (5) For uneven surfaces, wipe them with a clean cotton swab, etc. moistened with 70% ethanol.

9.2 Cleaning the Keyboard

WARNING

- Replace keyboard cover whenever it becomes stained and/or in contact with patient material/fluids or is suspected of being contaminated. Not doing so presents an infection risk.

Note

- Do not clean the entire keyboard with running water or disinfect it by dipping. If there is any breakage of or flaw on the keyboard cover, do not wipe the cover using a sterilizing chemical, etc. Doing so may lead to a failure or malfunction.

9.2.1 Cleaning the Keyboard

- (1) Turn off the processor.
- (2) Gently wipe off dust, dirt or foreign matter with clean lint-free gauze, etc.

9.2.2 Keyboard Cover and Replacement

In order to prevent adherence of debris, foreign matter or chemical solutions, as well as water entering, ordinarily keep the keyboard covered with a waterproof sheet. Replace the cover if debris or foreign matter, etc. has adhered to it or it has become contaminated, damaged or torn.

- (1) Turn off the processor.
- (2) Detach the keyboard from the processor.
- (3) Detach the waterproof sheet from the keyboard.
- (4) Cover the surface of the keyboard with a new waterproof sheet.

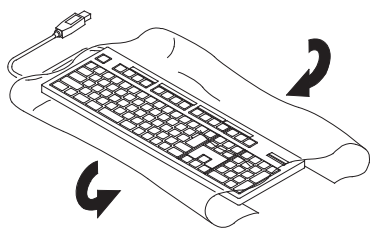

- (5) Secure the waterproof sheet to the bottom of the keyboard using adhesive tape.

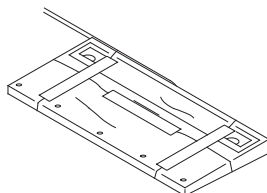

9.3 Cleaning the Dustproof Filters

- (1) Remove the louver from this product.

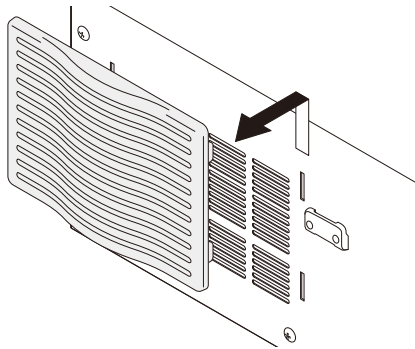

- (2) Remove the dustproof filter from the louver.

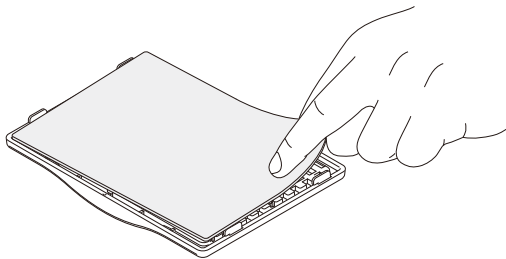

- (3) Remove dust from the dustproof filter.

- (4) Attach the dustproof filter to the louver. Align the center protrusion of the dustproof filter with the louver.

Align the dustproof filter with the protrusion of the louver, and then push the center protrusion of the dustproof filter into the louver to attach it.

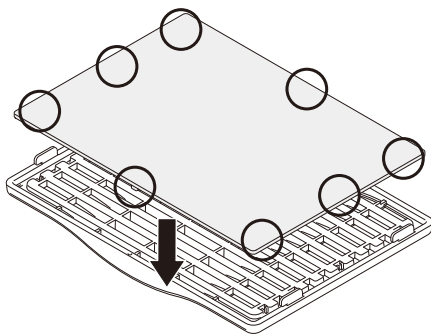

- (5)** Attach the louver to this product.
Attach the louver by pressing down the hooks of the louver.
Make sure that the louver is fully inserted into the light source.
Not doing so may cause equipment damage.

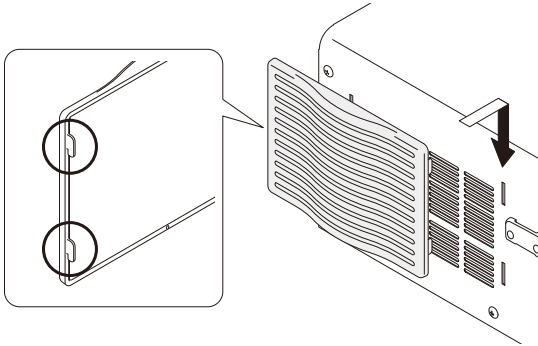

9.4 Storage

9.4.1 Storage of the processor

Note

- Store the equipment in a state where no force is applied to the cables. Do not store the equipment in a place which does not meet the storage conditions. The equipment may be damaged.

Store this product in a place that meets the following conditions.

<Storage Environment>

Temperature	-20 to +60°C
Humidity	10 to 90%RH (no dew condensation)
Pressure	70 to 106 kPa

Note

- **<Operating Environment>**
Non-operating conditions

Temperature	-10 to +45°C
Humidity	30 to 95%RH (no dew condensation)
Pressure	70 to 106 kPa

When the equipment has been out of use for a long period, check the operation again as performed at the installation.

→ “Chapter 6 Preparation and Inspection of the System”

This product uses a secondary battery for the clock and data recording. When this product has been off for a long time, the clock function may not be maintained (and the date and time may be incorrect).

→ “4.2 Initial Settings at the Time of Installation”

9.4.2 Storage of the Water Tank

For details on how to store the water tank, refer to the operation manual of the water tank.

9.5 Relocation

Note

- Do not bump or strongly shock the electric connector of the endoscope connected to the electric connector socket. Install the processor so that the scope connector or LG connector of the endoscope connected to the scope connector socket is not bumped or strongly shocked by surrounding objects. When operating an electric bed or similar device, avoid hitting it against the scope connector or LG connector of the endoscope connected to the scope connector socket. There is a risk of damaging the endoscope or processor.

- (1) Turn off the power to this product and cart in advance.

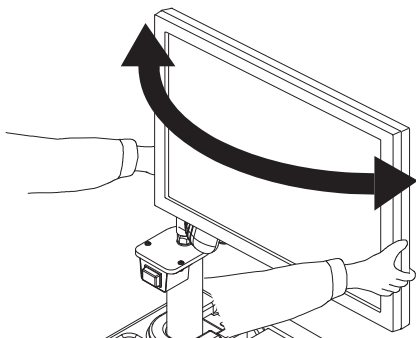

- (2) Unplug the power cord of the cart from the receptacle, and wind it around the handle on the rear side. Unlock the cart casters.

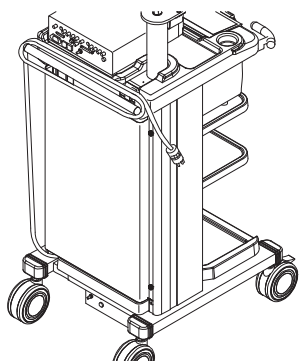

- (3) Move the cart carefully not to give any vibration or impacts to the equipment, paying close attention to bumps and slopes.

Note

- Use two persons to move the cart.
- Pay close attention to prevent the monitor and the scope hanger from hitting anything.

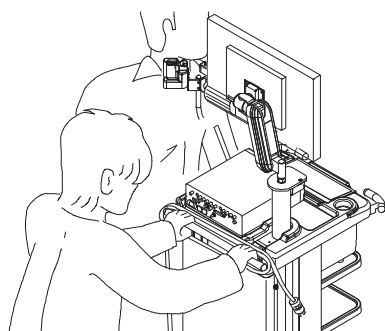

- (4) Lock the casters of the cart at the place where it is relocated.

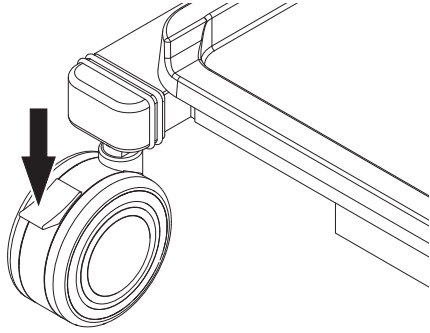

9.6 Cleaning and Disinfecting (or Sterilizing) the Water Tank

For details on how to clean and disinfect (or sterilize) the water tank, refer to the operation manual of the water tank.

Chapter 10 Troubleshooting

10.1 Troubleshooting

Phenomenon	Possible cause	Countermeasure
Turning "ON" the power button does not actuate this product (the power indicator lamp does not light up).	<ol style="list-style-type: none"> 1) The main switch on the cart is turned "OFF." 2) The power cord is connected incompletely. 3) The power cord is defective. 4) The receptacle is defective. 5) The fuse is blown. 	<ol style="list-style-type: none"> 1) Turn "ON" the main switch on the cart. 2) Connect the power cord properly. 3) Check the power cord. 4) Check that the rated voltage is supplied. 5) Consult your local FUJIFILM dealer.
The light does not turn on even if the Light button is pressed.	<ol style="list-style-type: none"> 1) The endoscope is not connected. 2) The safety switch for the scope socket is faulty. 3) The light source is faulty. 	<ol style="list-style-type: none"> 1) Securely lock the endoscope. 2) Consult your local FUJIFILM dealer. 3) Consult your local FUJIFILM dealer.
Images do not appear.	<ol style="list-style-type: none"> 1) The Endoscope is connected incompletely. 2) The main switch of the monitor is turned "OFF." 3) Monitor input is not selected correctly. 4) The monitor is not connected. 5) The monitor does not support Full HD output. 	<ol style="list-style-type: none"> 1) Connect the endoscope correctly. → "7.2 Connecting the Endoscope and Equipment" 2) Turn "ON" the monitor. 3) Select the input according to the line connected to INPUT. 4) Connect the monitor via the cable. 5) Press the [Ctrl], [Alt] and [S] keys at the same time to switch the screen resolution setting to SXGA. → "4.2 Initial Settings at the Time of Installation"

Phenomenon	Possible cause	Countermeasure
Images are dark.	1) The imaging section of the endoscope is damaged. 2) The endoscope is not connected completely. 3) The brightness level is approximately -4. 4) The iris mode is "Peak." 5) The system is malfunctioning due to phenomena such as electrostatic discharge. 6) The light source unit is faulty.	1) 5) 6) If an error message appears, follow the displayed instructions. If no error message appears, slowly withdraw the endoscope by following the instructions described in the operation manual of the endoscope in use. Stop using the equipment immediately, and consult your local dealer. 2) Connect the endoscope correctly. → "7.2 Connecting the Endoscope and Equipment" 3) Set the brightness level to approximately 0. → "7.8 Adjusting the Brightness" 4) Set the iris mode to "Ave." → "7.15 Switching the Iris Mode"

Phenomenon	Possible cause	Countermeasure
Highlight areas in images are too bright.	1) The imaging section of the endoscope is damaged. 2) The iris mode is "Ave." 3) The brightness level is approximately +5. 4) The system is malfunctioning due to such as electrostatic discharge. 5) The light source unit is faulty.	1) 4) 5) If an error message appears, follow the displayed instructions. If no error message appears, slowly withdraw the endoscope by following the instructions described in the operation manual of the endoscope in use. Stop using the equipment immediately, and consult your local dealer. 2) Set the iris mode to Peak. ➔ "7.15 Switching the Iris Mode" 3) Set the brightness level to approximately 0. ➔ "7.8 Adjusting the Brightness"
An image disappears during examination or treatment.	1) The imaging section of the endoscope is damaged. 2) The Endoscope is not connected completely. 3) The system is malfunctioning due to phenomena such as electrostatic discharge. 4) The light source unit is faulty. 5) The system malfunctions due to abnormal power supply conditions (such as voltage drop).	1) 3) 4) 5) If an error message appears, follow the displayed instructions. If no error message appears, slowly withdraw the endoscope by following the instructions described in the operation manual of the endoscope in use. Stop using the equipment immediately, and consult your local dealer. 2) Connect the endoscope correctly. ➔ "7.2 Connecting the Endoscope and Equipment"

Phenomenon	Possible cause	Countermeasure
A live image is not displayed after freeze mode is cancelled during examination or treatment.	The system is malfunctioning due to phenomena such as static charges.	If an error message appears, follow the displayed instructions. If no error message appears, slowly withdraw the endoscope by following the instructions described in the operation manual of the endoscope in use. Stop using the equipment immediately, and consult your local dealer.
An image is suddenly discolored during examination or treatment.	<ol style="list-style-type: none"> 1) The imaging section of the endoscope is damaged. 2) The system is malfunctioning due to phenomena such as electrostatic discharge. 3) The video signal cable is broken or shorting. 4) The endoscope is connected incompletely. 	<ol style="list-style-type: none"> 1) 2) 3) If an error message appears, follow the displayed instructions. If no error message appears, slowly withdraw the endoscope by following the instructions described in the operation manual of the endoscope in use. Stop using the equipment immediately, and consult your local dealer. 4) Connect the endoscope correctly. → "7.2 Connecting the Endoscope and Equipment"
Images are distorted.	<ol style="list-style-type: none"> 1) High-frequency interference. 2) The endoscope is connected incompletely. 	<ol style="list-style-type: none"> 1) Stop power supply to the electrosurgical unit to restore image output. The endoscope is working properly. 2) Connect the endoscope correctly. → "7.2 Connecting the Endoscope and Equipment"
Keyboard operation cannot be done.	The keyboard connector is not connected.	Connect the keyboard connector.
The peripherals do not operate.	<ol style="list-style-type: none"> 1) The peripherals are turned "OFF." 2) The peripherals are not connected. 	<ol style="list-style-type: none"> 1) Turn "ON" the peripherals. 2) Connect the peripherals via the cable.
An abnormal sound is heard from inside the processor.	The fan is faulty.	Consult your local FUJIFILM dealer.

Phenomenon	Possible cause	Countermeasure
The light disappears during examination or treatment.	1) The safety switch for the scope socket is faulty. 2) The light source unit is faulty.	If an error message appears, follow the displayed instructions. If no error message appears, slowly withdraw the endoscope by following the instructions described in the operation manual of the endoscope in use. Stop using the equipment immediately, and consult your local dealer.

Note

- Wait for 5 seconds or more before turning the power back to ON.
- For details on how to operate the endoscope, refer to the operation manual of the endoscope.

10.2 Error Messages

If an error occurs, an error message appears on the monitor.

Note

- For product inquiries and support, the displayed error message and error code should be reported to your local FUJIFILM dealer.

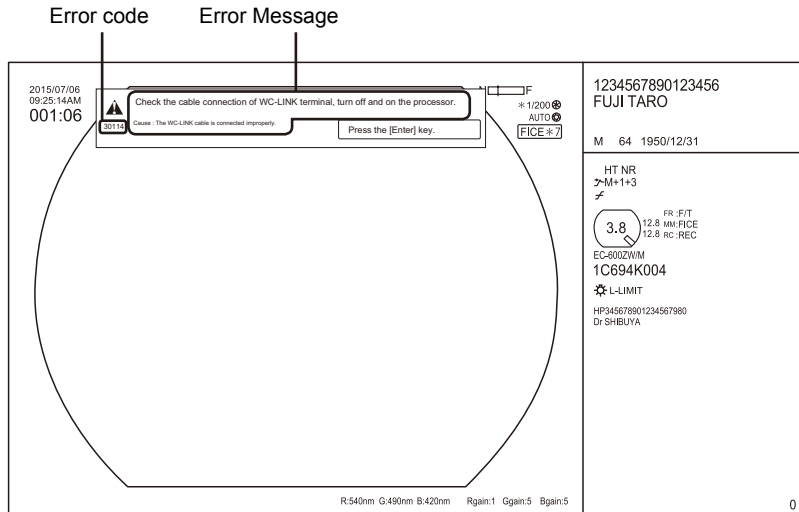

Error message	Possible cause	Countermeasure
Check the cable connection of WC-LINK terminal, turn off and on the processor. Cause: The WC-LINK cable is connected improperly.	There is a problem with the WC-LINK connection.	Connect the WC-LINK cable securely.
Check the cable connection of WC-LINK terminal, turn off and on the processor. Cause: The WC-LINK cable is connected improperly.		
Unplug and plug back endoscope, reset the processor. If the problem persists, contact your local FUJIFILM dealer. Cause: The Light source unit is in abnormal state.	The light source unit is faulty.	Consult your local FUJIFILM dealer. *
Unplug and plug back endoscope, reset the processor. If the problem persists, contact your local FUJIFILM dealer. Cause: The Light source unit is in abnormal state.		

Error message	Possible cause	Countermeasure
<p>Unplug and plug back endoscope, reset the processor and the light source. If the problem persists, contact your local FUJIFILM dealer. Cause: The light source unit is in abnormal state.</p>	The fan is faulty.	Consult your local FUJIFILM dealer. *
<p>Unplug and plug back endoscope, reset the processor and the light source. If the problem persists, contact your local FUJIFILM dealer. Cause: The light source unit is in abnormal state.</p>		
<p>Unplug and plug back endoscope, reset the processor. If the problem persists, contact your local FUJIFILM dealer. Cause: The processor is in abnormal state.</p>	The processor is faulty.	Consult your local FUJIFILM dealer. *
<p>Unplug and plug back endoscope, reset the processor. If the problem persists, contact your local FUJIFILM dealer. Cause: The processor is in abnormal state.</p>		
<p>Unplug and plug back endoscope, reset the processor. If the problem persists, contact your local FUJIFILM dealer. Cause: The endoscope is in abnormal state.</p>	The endoscope is faulty.	Consult your local FUJIFILM dealer. *
<p>Unplug and plug back endoscope, reset the processor. If the problem persists, contact your local FUJIFILM dealer. Cause: The endoscope is in abnormal state.</p>		
<p>Clean the equipment in the proper way as specified. If the problem persists, contact your local FUJIFILM dealer. Cause: Light source unit or endoscope is connected improperly.</p>	The power cannot be supplied to the 700 system scope since the equipment is dusty or dirty.	<p>Clean the equipment in the proper way as specified. When the equipment is dusty or dirty, wipe it gently with clean lint-free gauze, or similar item. If this message appears again even after cleaning is performed, consult your local FUJIFILM dealer. *</p>
<p>Clean the equipment in the proper way as specified. If the problem persists, contact your local FUJIFILM dealer. Cause: Light source unit or endoscope is connected improperly.</p>		

Error message	Possible cause	Countermeasure
Connect or disconnect the endoscope when the EXAM. button lights orange or when the power is OFF.	Removal of the endoscope is attempted while the EXAM. button lights up in blue.	The endoscope should be mounted or removed in the following situations: When the power is turned "OFF," or when the EXAM. button lights up in orange after pressing and holding the EXAM. button for approximately two seconds.
Connect or disconnect the endoscope when the EXAM. button lights orange or when the power is OFF.		
To end examination, cancel freeze mode to display a live image.	Finishing the examination is attempted while the image is frozen.	Finish the examination after canceling freeze mode.
To end examination, cancel freeze mode to display a live image.		
Connected scope cannot be used.	The equipment is started up or inspection is started with a non-applicable endoscope connected.	Connect the endoscope applicable to this product. ➔ "Chapter 11 Main Specification"
Connected scope cannot be used.		
Connection to FTP server cannot be established. Cause: FTP server is not connected to the network or network setting is incorrect.	1) The FTP server is not connected to the network.	1) Turn on the FTP server.
Connection to FTP server cannot be established. Cause: FTP server is not connected to the network or network setting is incorrect.	2) The network setting is improper.	2) Check the connections such as cable and select "Try Reconnection".
	3) The network setting for the processor is abnormal.	3) Check with the system administrator, or consult your local FUJIFILM dealer. *
Login to FTP server denied. Check the network setting. Cause: Login name and password settings are incorrect.	The network setting for the processor is abnormal.	Check with the system administrator, or consult your local FUJIFILM dealer. *
Login to FTP server denied. Check the network setting. Cause: Login name and password settings are incorrect.		
Could not connect to the network. Cause: Network setting is incorrect or network is in abnormal state.	Manual transfer is attempted even though the network connection is disabled.	Check whether or not the network connection is enabled.
Could not connect to the network. Cause: Network setting is incorrect or network is in abnormal state.		

Error message	Possible cause	Countermeasure
Transferring examination data to the server failed. Check the network setting. Cause: Network connection to the server failed or network setting is incorrect.	The FTP server is not connected to the network or the network setting is incorrect.	Check the cable connections and then make sure that network connection is established between the system and the FTP server.
Transferring examination data to the server failed. Check the network setting. Cause: Network connection to the server failed or network setting is incorrect.		
Initialization of External Memory failed. Check External Memory.	Initialization of the external storage device fails.	Remove/insert the external storage device from/into the memory slot once, and retry initialization.
Initialization of External Memory failed. Check External Memory.		
Set External Memory. If this message appears even when External Memory is set, contact your local FUJIFILM dealer.	1) No external storage device is inserted. 2) The memory slot is broken.	1) Insert an external storage device. 2) Consult your local FUJIFILM dealer. *
Set External Memory. If this message appears even when External Memory is set, contact your local FUJIFILM dealer.		
Internal Memory has a problem and cannot be used. Initialize Internal Memory. Cause: Internal Memory is not initialized or its file system is corrupted.	1) The internal storage device is not initialized. 2) The file system of the internal storage device is corrupted.	Initialize the internal storage device. ➔ "7.15 Switching the Iris Mode"
Internal Memory has a problem and cannot be used. Initialize Internal Memory. Cause: Internal Memory is not initialized or its file system is corrupted.		
Internal Memory is full. Cause: Free space of Internal Memory is insufficient.	The internal storage device does not have sufficient free space.	Copy the image data to an external storage device or transfer them to the image server to secure the free space in the internal storage device.
Internal Memory is full. Cause: Free space of Internal Memory is insufficient.		
External Memory is full. Cause: Free space of External Memory is insufficient.	There is no free space in the external storage device.	Prepare a new external storage device.
External Memory is full. Cause: Free space of External Memory is insufficient.		

Error message	Possible cause	Countermeasure
Turn printing device off and back on. If the problem persists, contact your local FUJIFILM dealer. Cause: Error occurred in printing device.	The printer is faulty.	Consult your local FUJIFILM dealer. *
Turn printing device off and back on. If the problem persists, contact your local FUJIFILM dealer. Cause: Error occurred in printing device.		
Printer cannot be recognized. Check the printer power and cable connection. To print after examination, select the [Cancel] button.	1) The printer is not turned on. 2) The printer is not connected correctly.	1) Turn on the printer. 2) Check the printer connection.
Printer cannot be recognized. Check the printer power and cable connection. To print after examination, select the [Cancel] button.		
Printing in progress. Load images after printing is finished.	A trigger command is sent while the printer is printing.	Wait until printing is finished.
Printing in progress. Load images after printing is finished.		
Printer door is open. Check printer.	Printing is executed with the printer door open.	Close the printer door.
Printer door is open. Check printer.		
Printer paper has run out. Set printer paper.	Printing is executed without paper in the printer.	Put paper in the printer.
Printer paper has run out. Set printer paper.		
Ink sheet is not set in printer. Set ink sheet.	Printing is executed without ink sheet in the printer.	Set ink sheet in the printer.
Ink sheet is not set in printer. Set ink sheet.		
Printer ink sheet has run out. Replace ink sheet.	The ink sheet in the printer is finished.	Set ink sheet in the printer.
Printer ink sheet has run out. Replace ink sheet.		
Paper jamming occurred in printer. Remove paper.	The paper in the printer is jammed.	Remove the jammed paper.
Paper jamming occurred in printer. Remove paper.		

Error message	Possible cause	Countermeasure
Printer paper and ink sheet sizes do not match. Match printer paper and ink sheet sizes.	The sizes of ink sheet and paper do not correspond to each other.	Set paper and ink sheet of correct size in the printer.
Printer paper and ink sheet sizes do not match. Match printer paper and ink sheet sizes.		
Connection to the video recorder cannot be confirmed. Check the video recorder. Cause: Video recorder is turned off or video recorder and processor are connected improperly.	The video recorder is not turned on.	Check the setting of video recorder power supply, cable connection and communication speed.
Connection to the video recorder cannot be confirmed. Check the video recorder. Cause: Video recorder is turned off or video recorder and processor are connected improperly.		
Video recorder software error occurred.	1) The connection and setting of the video recorder are not performed properly.	1) Check the setting of video recorder power supply, cable connection and communication speed.
Video recorder software error occurred.	2) The video recorder is faulty.	2) Consult your local FUJIFILM dealer. *
No disk is inserted in the video recorder. Insert a disk.	No disk is in the video recorder.	Remove the disk, and insert a new disk into the video recorder.
No disk is inserted in the video recorder. Insert a disk.		
The disk in the video recorder is full. Replace it with a new disk.	The disk inserted into the video recorder is full.	Remove the disk, and insert a new disk into the video recorder.
The disk in the video recorder is full. Replace it with a new disk.		
The disk in the video recorder is not supported. Insert a "DVD-RAM" or "DVD-R" disk.	The inserted disk is not supported by the video recorder.	Remove the disk, and insert the supported disk into the video recorder.
The disk in the video recorder is not supported. Insert a "DVD-RAM" or "DVD-R" disk.		

Error message	Possible cause	Countermeasure
Data cannot be written on the disk in the video recorder. Insert a recordable disk. Cause: Disk is full or maximum number of recordable files are already stored.	The disk is write-protected.	Remove the disk to cancel the write protection.
Data cannot be written on the disk in the video recorder. Insert a recordable disk. Cause: Disk is full or maximum number of recordable files are already stored.		
The disk in the video recorder is not recordable. Check the disk. At the time of disk status confirmation, the status "not recordable" is returned from the device.	1) The disk is corrupted. 2) The disk is written.	Remove the disk, and insert a new disk into the video recorder.
The disk in the video recorder is not recordable. Check the disk. At the time of disk status confirmation, the status "not recordable" is returned from the device.		
The disk in the video recorder is not formatted. Insert a formatted disk. Cause: DVD-RAM disk is not formatted.	The disk is not initialized.	Remove the disk to initialize.
The disk in the video recorder is not formatted. Insert a formatted disk. Cause: DVD-RAM disk is not formatted.		
The video recorder is busy.	A trigger command is sent when the video recorder is busy.	Wait until the message disappears.
The video recorder is busy.		
Disk tray is open. Check the disk tray.	Video recording is executed with the disk tray open.	Correct the error on the video recorder.
Disk tray is open. Check the disk tray.		
Patient has been switched during examination. Recording will be continued.	The patient is switched during video recording.	Wait until the message disappears.
Patient has been switched during examination. Recording will be continued.		

Error message	Possible cause	Countermeasure
Preparation for printing is in progress. Please wait for a while.	A Trigger command for a new image is sent immediately after printing is started.	Wait until the message disappears.
Preparation for printing is in progress. Please wait for a while.		
No input signal to the printer. Check the input cable or device settings.	The connection and setting of printer are not correct.	Check the cable connection and setting of printer.
No input signal to the printer. Check the input cable or device settings.		
No images are loaded to the printer.	Printing is attempted without an image loaded.	Load the image to print it again.
No images are loaded to the printer.		
Adjusting head temperature.	The printer head temperature rises excessively.	Wait until the message disappears.
Adjusting head temperature.		
Printer paper tray is full. Remove paper.	The paper tray is full.	Remove paper from the paper tray.
Printer paper tray is full. Remove paper.		
Printer cannot be recognized. Check the printer power and cable connection. To cancel printing, select the [Cancel] button.	1) The digital printer is not turned on. 2) The USB cable is not connected to the digital printer. 3) The setting of digital printer is abnormal.	Check the power supply, cable connection and setting of digital printer.
Printer cannot be recognized. Check the printer power and cable connection. To cancel printing, select the [Cancel] button.		
Paper jamming occurred in printer. Remove paper. To cancel printing, select the [Cancel] button.	The paper in the digital printer is jammed.	Remove the jammed paper.
Paper jamming occurred in printer. Remove paper. To cancel printing, select the [Cancel] button.		
Printer ink sheet is incorrect. Replace it with a correct ink sheet. To cancel printing, select the [Cancel] button.	The ink sheet information cannot be detected.	Reset the ink sheet in the printer.
Printer ink sheet is incorrect. Replace it with a correct ink sheet. To cancel printing, select the [Cancel] button.		

Error message	Possible cause	Countermeasure
Printer paper and ink sheet sizes do not match. Match printer paper and ink sheet sizes. To cancel printing, select the [Cancel] button.	The sizes of ink sheet and paper do not correspond to each other.	Set the specified paper and ink sheet in the printer.
Printer paper and ink sheet sizes do not match. Match printer paper and ink sheet sizes. To cancel printing, select the [Cancel] button.		
Printer paper has run out. Set printer paper. To cancel printing, select the [Cancel] button.	Printing is executed without paper in the digital printer.	Put paper in the printer.
Printer paper has run out. Set printer paper. To cancel printing, select the [Cancel] button.		
Printer door is open. Check printer.	Printing is executed with the door of the digital printer open.	Correct the error on the printer.
Printer door is open. Check printer.		
Turn printing device off and back on. If the problem persists, contact your local FUJIFILM dealer. Cause: Error occurred in printing device.	The digital printer is faulty.	Consult your local FUJIFILM dealer. *
Turn printing device off and back on. If the problem persists, contact your local FUJIFILM dealer. Cause: Error occurred in printing device.		
Preparation for printing is in progress. Please wait for a while. To cancel printing, select the [Cancel] button.	An image to be printed is sent during initialization of the digital printer setup.	Wait until the message disappears.
Preparation for printing is in progress. Please wait for a while. To cancel printing, select the [Cancel] button.		
Adjusting the printer-head temperature. Please wait for a while. To cancel printing, select the [Cancel] button.	1) The temperature is abnormally high in the printer. 2) The printer is faulty.	1) Wait until the message disappears. 2) Consult your local FUJIFILM dealer. *
Adjusting the printer-head temperature. Please wait for a while. To cancel printing, select the [Cancel] button.		

Error message	Possible cause	Countermeasure
Unplug and plug back endoscope, reset the processor and the light source. If the problem persists, contact your local FUJIFILM dealer. Cause: It failed in the initialization of the panel button and the foot switch.	Recognition of the panel button and foot switch has failed.	Turn off the processor, wait 5 seconds or longer, and then turn on the processor.
Unplug and plug back endoscope, reset the processor and the light source. If the problem persists, contact your local FUJIFILM dealer. Cause: It failed in the initialization of the panel button and the foot switch.		
Communication error with DICOM GW equipment. Check the connection.	Serial communication with the DICOM GW equipment has failed.	Make sure that the cable is connected properly. If this error occurs frequently, consult your local FUJIFILM dealer. *
Communication error with DICOM GW equipment. Check the connection.		
A communication error is detected with SU equipment. Check the connection.	Serial communication with the ultrasonic endoscope has failed.	Make sure that the cable is connected properly. If this error occurs frequently, consult your local FUJIFILM dealer.
A communication error is detected with SU equipment. Check the connection.		

- * For inquiry to your local FUJIFILM dealer, the error message and the error code displayed with the error message are required.

11.1 Specification

CAUTION

- If the range of the operating environment for a peripheral device is narrower than the range of the operating environment for this product, use this product within the range of the operating environment for the peripheral device.

◆ Classification of Medical Electrical Equipment

1. Type of protection against electric shock:

Class I equipment
(Power supply: Protective earth plug)

2. Degree of protection against electric shock:

Type BF applied part

3. Degree of explosion protection:

Use is prohibited in an oxygen-rich environment or in a flammable gas atmosphere.

4. Degree of protection against ingress of water:

IPX0

5. Mode of operation:

Continuous operation

◆ Applied Part

Insertion portion of applicable endoscope

◆ Specification

Power	100 - 240 V ~ 50/60 Hz
Current consumption (rated)	2.0-1.1 A
Fuse	T3.15AH 250V×2 (Rating: 3.15A/250V)
Type of color	NTSC/PAL
Video output	DVI (Resolution: 1280 × 1024 pixels, 1920 × 1080 pixels)
Light control	Automatic light control by the control signal
Light cooling method	Forced air cooling
Air supply pump	HI/MID/LOW/OFF
Maximum air supply pressure	65kPa
Maximum water supply pressure	65kPa
Illumination source	LED
Maximum light output	750lm or less (Measured with our jig)
Optical radiation safety (LED for infrared communication)	Class 1 LED product *1 (IEC 60825-1: 1993+A1: 1997+A2: 2001: 2007)
Power transmission frequency	110 to 205 kHz
Effective radiated power	15 W or less
Serial control	UP-55MD
Image pickup method	Simultaneous *2
Iris mode	AUTO/PEAK/AVE
Image zoom *3	Electronic zoom × 1.00 to × 2.00 (0.05 steps)
Memory	Patient data: 45 patients Clinical procedure: 20 types Dr. Name: 20 doctors Image Setup Page: 5 patterns
Built-in clock	Date, time (back up from the secondary battery: ML2430-HJ1)
Shooting counter	Adding up display
Applicable endoscope	700 system scopes, 600 system scopes, 500 system scopes *4 *5
Dimensions (W × H × D)	395 × 210 × 485 mm (including projection)
Mass	15.0 kg

*1 “Chapter 3 Name and Function of Each Part” > “3.1 Front Panel” > “20. Communication Window (LED)” falls into this class.

*2 Image pickup method using the imaging sensor with color filters (red, green and blue) at the distal end of scope. White light is used as illumination light.

*3 The zoom ratio of some 530 series scopes is × 1.00 to × 1.95.

- *4 Depending on the model, smoothness of video images may vary due to the difference in software version.
- *5 Excluding 590 series scope, EG-530UT2, EG-530UT, EG-530UR2 and EG-530UR.

◆ Operating Environment

Operating conditions

Temperature	+10 to +40°C
Humidity	30 to 85%RH (no dew condensation)
Pressure	70 to 106 kPa

Non-operating condition

Temperature	-10 to +45°C
Humidity	30 to 95%RH (no dew condensation)
Pressure	70 to 106 kPa

◆ Transport and Storage Environment

Temperature	-20 to +60°C
Humidity	10 to 90%RH (no dew condensation)
Pressure	70 to 106 kPa

◆ Term of Validity/Period for Use (Durability)

The term of validity (durability) is 6 years from the first use of this product, providing that this product undergoes periodic servicing. "Based on our company's criteria"

◆ Input/Output Connector

(1) Image output connector

VIDEO	1.0 Vp-p/75 Ω (NTSC/PAL)	1 channel
S VIDEO	Y: 1.0 Vp-p/75 Ω (NTSC/PAL) C: 0.3 Vp-p/75 Ω	1 channel
RGB TV (D-sub 15 p)	RGB: 0.7 Vp-p/75 Ω (NTSC/PAL) SYNC: TTL, 2.0 Vp-p/75 Ω	1 channel
DVI-D (24 p)	Digital	2 channels

(2) Control connector

WC-LINK (37 p)		1 channel
REMOTE (BNC)		2 channels
Peripherals (D-sub 9 p)	RS-232C *	2 channels
Keyboard	USB1.1 *	1 channel
Reader	USB1.1 *	1 channel
Digital printer	USB2.0 *	1 channel
Footswitch (Din 5 p)		1 channel
Network (RJ-45)	10/100 BASE *	1 channel

◆ Block Diagram

This device is made up of the following parts: power supply, controller, image processor, front panel, interface, patient mounting section, light source controller, light source drive, and scope controller. The patient mounting section and scope controller are floating. Power, control signals, illumination light, and air are supplied to the endoscope to be connected. The image signals received from the endoscope are processed and converted to image information. The device is equipped with functions to display on screen, print, record, and send image information.

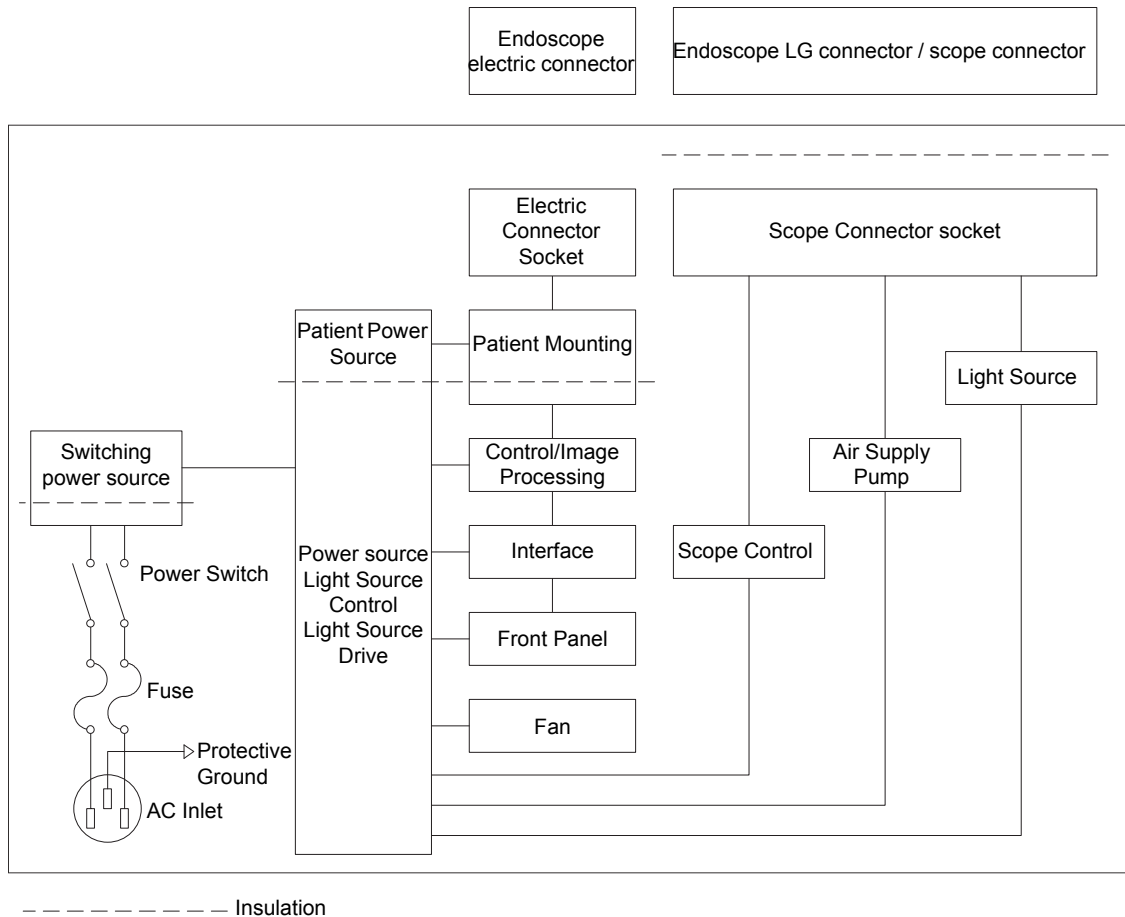

◆ Medical Device Directive

This product complies with the requirements of European Directive 93/42/EEC.
Classification : Class IIa

CE 0123

11.2 Electromagnetic Compatibility (EMC) Information

Medical electronic equipment requires special care with regards to EMC. It must be installed and used according to the EMC information provided in Table 1 through Table 4 if both this product and a Video Endoscope ^{*1}, which are used in combination, comply with the requirements of EN 60601-1-2:2015 or that provided in Table 5 through Table 8 if a Video Endoscope ^{*1} complies with the requirements of EN 60601-1-2:2007.

*1 Refer to the operation manual of the Video Endoscope.

<Electromagnetic Emission Compliance Information and Guidance>

Table 1

Guidance and Manufacturer Declaration - Electromagnetic Emission -		
This device is intended for use in the following prescribed electromagnetic environments. Customers and users of this product are advised to check that it is being used in such environments.		
Emission standard	Compliance	Guidance
RF emissions EN 55011	Group 1	This product uses RF energy for internal functions only. Accordingly, the RF emission is very low and unlikely to cause any interference with nearby electronics.
RF emissions EN 55011	Class B (Combination with the 700 system scope, EB-580S or EB-580T) Class A (Combinations other than above)	[RF emissions] With the Class B combination, this product is suitable for use in all establishments, including domestic establishments and those directly connected to the public low-voltage power supply network that supplies buildings used for domestic purposes. With the Class A combination, this product is intended for use in medical facilities and commercial facilities.
Harmonic emissions EN 61000-3-2	Class A	Therefore, if this product is used in domestic establishments, electromagnetic interference may occur in any devices. In addition, this product may not offer adequate protection to radio-frequency communication services. The user may need to take mitigation measures, such as relocating or reorienting the equipment. In these cases, it is recommended to take corrective measures according to "Chapter 1 Precautions."
Voltage fluctuation/flicker emissions EN 61000-3-3	Applicable	

<Electromagnetic Immunity Compliance Information and Guidance>

Table 2

Guidance and Manufacturer Declaration - Electromagnetic Immunity -

This device is intended for use in the following prescribed electromagnetic environments. Customers and users of this product are advised to check that it is being used in such environments.

Immunity test	IEC 60601 Test level	Compliance level	Guidance
Electrostatic discharge (ESD) IEC/EN 61000-4-2	±8 kV contact ±2 kV air ±4 kV air ±8 kV air ±15 kV air	±8 kV contact ±2 kV air ±4 kV air ±8 kV air ±15 kV air	Floors should be wood, concrete, or ceramic tile. If floors are covered with synthetic material, the relative humidity should be at least 30%.
Electrical fast transient/burst IEC/EN 61000-4-4	±2 kV for power supply lines ±1 kV for input/output lines	±2 kV for power supply lines ±1 kV for input/output lines	Main power quality should be that of a typical commercial or hospital environment.
Surge IEC/EN 61000-4-5	±0.5 kV, ±1.0 kV line to line ±0.5 kV, ±1.0 kV, ±2.0 kV line to earth	±0.5 kV, ±1.0 kV line to line ±0.5 kV, ±1.0 kV, ±2.0 kV line to earth	Main power quality should be that of a typical commercial or hospital environment.
Voltage dips, short interruptions and voltage variations on power supply input lines IEC/EN 61000-4-11	0% U_T for 0.5 cycles and 1 cycles 70% U_T for 0.5 seconds 0% U_T for 5 seconds	0% U_T for 0.5 cycles and 1 cycles 70% U_T for 0.5 seconds 0% U_T for 5 seconds	Main power quality should be that of a typical commercial or hospital environment. If the user of this product requires continued operation during power mains interruptions, it is recommended that this product is powered from an uninterruptible power supply or battery.
Power frequency (50/60 Hz) magnetic field IEC/EN 61000-4-8	30 A/m	30 A/m	The power frequency magnetic field should have the same level of characteristics as a common location in standard business and hospital environments.

Note

- U_T is the a.c. mains voltage prior to application of the test level.

<Portable and Mobile RF Communications Equipment Compliance Information and Guidance>

Table 3

Guidance and Manufacturer Declaration - Electromagnetic Immunity -

This device is intended for use in the following prescribed electromagnetic environments. Customers and users of this product are advised to check that it is being used in such environments.

Immunity test	EN 60601 Test level	Compliance level	Guidance
Conducted RF IEC 61000-4-6	3 Vrms 150 kHz to 80 MHz 6 Vrms ISM Frequency Band ^c	3 Vrms 6 Vrms ISM Frequency Band ^c	<p>Portable and mobile RF communications equipment should be used no closer to any part of this product, including cables, than the recommended separation distance calculated from the equation applicable to the frequency of the transmitter.</p> <p>Recommended separation distance</p> $d = 1.2 \sqrt{P}$ $d = 1.2 \sqrt{P} \text{ 80 MHz to 800 MHz}$ $d = 2.3 \sqrt{P} \text{ 800 MHz to 2.7 GHz}$ <p>Where "P" is the maximum output power rating of the transmitter in watts (W) according to the transmitter manufacturer and "d" is the recommended separation distance in meters (m). The electric field intensity from a fixed RF transmitter determined by an electromagnetic field study^a should be lower than the compliance level in each frequency range^b.</p> <p>Interference may occur near devices that display the following symbol.</p> 
Radiated RF IEC/EN 61000-4-3	3 V/m 80 MHz to 2.7 GHz	3 V/m	

Immunity to proximity fields from RF wireless communications equipment IEC/EN 61000-4-3	380 - 390 MHz, 27 V/m	380 - 390 MHz, 27 V/m	Degradation of the performance of this product could result if portable RF communications equipment is used closer than 30 cm to any part of this product.
	430 - 470 MHz, 28 V/m	430 - 470 MHz, 28 V/m	
	704 - 787 MHz, 9 V/m	704 - 787 MHz, 9 V/m	
	800 - 960 MHz, 28 V/m	800 - 960 MHz, 28 V/m	
	1422 - 1512 MHz, 10 V/m	1422 - 1512 MHz, 10 V/m	
	1700 - 1990 MHz, 28 V/m	1700 - 1990 MHz, 28 V/m	
	2400 - 2570 MHz, 28 V/m	2400 - 2570 MHz, 28 V/m	
	3480 - 3600 MHz, 10 V/m	3480 - 3600 MHz, 10 V/m	
	5100 - 5800 MHz, 9 V/m	5100 - 5800 MHz, 9 V/m	

Note

- At 80 MHz and 800 MHz, the higher frequency range applies.
 - These guidelines may not apply in all situations. Electromagnetic propagation is affected by absorption and reflection from structures, objects and people.
-
- a. Field strengths from fixed transmitters, such as base stations for radio (cellular/cordless) telephones and land mobile radios, amateur radio, AM and FM radio broadcast and TV broadcast cannot be predicted theoretically with accuracy. To assess the electromagnetic environment due to fixed RF transmitters, an electromagnetic site survey should be considered. If the measured field strength in the location in which this product is used exceeds the applicable RF compliance level above, this product should be observed to verify normal operation. If abnormal performance is observed, additional measures may be necessary, such as re-orienting or relocating this product.
 - b. Over the frequency range 150 kHz to 80 MHz, field strengths should be less than 3 V/m.
 - c. Frequency bands of 6.765 MHz to 6.795 MHz, 13.553 MHz to 13.567 MHz, 26.957 MHz to 27.283 MHz, or 40.66 MHz to 40.70 MHz
-

<Recommended Separation Distance Between Portable and Mobile RF Communications Equipment and this Product>

Table 4

Recommended separation distance between portable and mobile RF communications equipment and this product.

This product is intended for use in an electromagnetic environment in which radiated RF disturbances are controlled. The customer or the user of this product can help prevent electromagnetic interference by maintaining a minimum distance between portable and mobile RF communications equipment (transmitters) and this product as recommended below, according to the maximum output power of the communications equipment.

Rated maximum output power of transmitter P (W)	Separation distance related to frequency of the transmitter (m)		
	150kHz to 80MHz $d=1.2\sqrt{P}$	80MHz to 800MHz $d=1.2\sqrt{P}$	800MHz to 2.5GHz $d=2.3\sqrt{P}$
0.01	0.12	0.12	0.23
0.1	0.38	0.38	0.73
1	1.2	1.2	2.3
10	3.8	3.8	7.3
100	12	12	23

For transmitters rated at a maximum output power not listed above, the recommended separation distance d in metres (m) can be estimated using the equation applicable to the frequency of the transmitter, where P is the maximum output power rating of the transmitter in watts (W) according to the transmitter manufacturer.

Note

- At 80 MHz and 800 MHz, the separation distance for the higher frequency range applies.
- These guidelines may not apply in all situations. Electromagnetic propagation is affected by absorption and reflection from structures, objects and people.

• Cables

Name	Maximum length	Specification
S Video cable	3m	Shielded cable with a characteristic impedance of 75Ω
Video cable	3m	Shielded cable with a characteristic impedance of 75Ω
RGB TV cable	3m	Shielded cable with a characteristic impedance of 75Ω (R, G, B, Sync)
DVI-D cable *1	5m	Shielded cable with a differential signal characteristic impedance of 100Ω Cable compliant with the DVI standard
LAN cable		Cat5e or higher, UTP type and straight cable
WC-LINK cable		Supplied with this product

Use the cable supplied with the printer to connect this product to the digital printer.

*1 Use the cable supplied with the monitor.

<Electromagnetic Emission Compliance Information and Guidance>

Table 5

Guidance and Manufacturer Declaration - Electromagnetic Emission -		
This device is intended for use in the following prescribed electromagnetic environments. Customers and users of this product are advised to check that it is being used in such environments.		
Emission standard	Compliance	Guidance
RF emissions EN 55011	Group 1	This product uses RF energy for internal functions only. Accordingly, the RF emission is very low and unlikely to cause any interference with nearby electronics.
RF emissions EN 55011	Class B (Combination with the 700 system scope, EB-580S or EB-580T) Class A (Combinations other than above)	[RF emissions] With the Class B combination, this product is suitable for use in all establishments, including domestic establishments and those directly connected to the public low-voltage power supply network that supplies buildings used for domestic purposes. With the Class A combination, this product is
Harmonic emissions EN 61000-3-2	Class A	intended for use in medical facilities and commercial facilities.
Voltage fluctuation/flicker emissions EN 61000-3-3	Applicable	Therefore, if this product is used in domestic establishments, electromagnetic interference may occur in any devices. In addition, this product may not offer adequate protection to radio-frequency communication services. The user may need to take mitigation measures, such as relocating or reorienting the equipment. In these cases, it is recommended to take corrective measures according to "Chapter 1 Precautions."

<Electromagnetic Immunity Compliance Information and Guidance>

Table 6

Guidance and Manufacturer Declaration - Electromagnetic Immunity -			
This device is intended for use in the following prescribed electromagnetic environments. Customers and users of this product are advised to check that it is being used in such environments.			
Immunity test	EN 60601 Test level	Compliance level	Guidance
Electrostatic discharge (ESD) EN 61000-4-2	±6kV contact ±8kV air	±2kV contact ±4kV contact ±6kV contact ±2kV air ±4kV air ±8kV air	Floors should be wood, concrete, or ceramic tile. If floors are covered with synthetic material, the relative humidity should be at least 30%.
Electrical fast transient/burst EN 61000-4-4	±2kV for power supply lines ±1kV for input/output lines	±2kV for power supply lines ±1kV for input/output lines	Main power quality should be that of a typical commercial or hospital environment.
Surge EN 61000-4-5	±1kV line to line ±2kV line to earth	±1kV line to line ±2kV line to earth	Main power quality should be that of a typical commercial or hospital environment.
Voltage dips, short interruptions and voltage variations on power supply input lines EN 61000-4-11	< 5% U_T (dip in > 95% U_T) for 0.5 cycles 40% U_T (dip in 60% U_T) for 5 cycles 70% U_T (dip in 30% U_T) for 25 cycles < 5% U_T (dip in > 95% U_T) for 5 seconds	< 5% U_T (dip in > 95% U_T) for 0.5 cycles 40% U_T (dip in 60% U_T) for 5 cycles 70% U_T (dip in 30% U_T) for 25 cycles < 5% U_T (dip in > 95% U_T) for 5 seconds	Main power quality should be that of a typical commercial or hospital environment. If the user of this product requires continued operation during power mains interruptions, it is recommended that this product is powered from an uninterruptible power supply or battery.
Power frequency (50/60 Hz) magnetic field EN 61000-4-8	3 A/m	3 A/m	The power frequency magnetic field should have the same level of characteristics as a common location in standard business and hospital environments.

Note

- U_T is the a.c. mains voltage prior to application of the test level.

<Portable and Mobile RF Communications Equipment Compliance Information and Guidance>

Table 7

Guidance and Manufacturer Declaration - Electromagnetic Immunity -

This device is intended for use in the following prescribed electromagnetic environments. Customers and users of this product are advised to check that it is being used in such environments.

Immunity test	EN 60601 Test level	Compliance level	Guidance
Conducted RF EN 61000-4-6	3Vrms 150kHz to 80MHz	3Vrms	<p>Portable and mobile RF communications equipment should be used no closer to any part of this product, including cables, than the recommended separation distance calculated from the equation applicable to the frequency of the transmitter.</p> <p>Recommended separation distance $d = 1.2 \sqrt{P}$ $d = 1.2 \sqrt{P}$ 80MHz to 800MHz $d = 2.3 \sqrt{P}$ 800MHz to 2.5GHz Where "P" is the maximum output power rating of the transmitter in watts (W) according to the transmitter manufacturer and "d" is the recommended separation distance in meters (m). The electric field intensity from a fixed RF transmitter determined by an electromagnetic field study^a should be lower than the compliance level in each frequency range^b.</p> <p>Interference may occur near devices that display the following symbol.</p> 
Radiated RF EN 61000-4-3	3V/m 80MHz to 2.5GHz	3V/m	

Note

- For 80 and 800 MHz, apply the higher frequency range.
- These guidelines do not apply to all circumstances. Electromagnetic propagation is affected by absorption and reflection by buildings, items, and people.

- a. Electric field intensity from fixed transmitters such as wireless (mobile / cordless) telephone base stations, land mobile radio base stations, amateur radio, AM and FM radio broadcasts, and TV broadcasts cannot be predicted accurately in theory.

An electromagnetic field survey should be considered to estimate the electromagnetic environment due to fixed RF transmitters. When the measured electric field intensity in the location in which this product is used exceeds the RF compatibility level applied above, this product should be monitored to verify whether it is operating normally. When abnormal operation has been confirmed, it may be necessary to take additional measures, such as relocation or re-installation of this product.

Guidance and Manufacturer Declaration - Electromagnetic Immunity -

This device is intended for use in the following prescribed electromagnetic environments. Customers and users of this product are advised to check that it is being used in such environments.

Immunity test	EN 60601 Test level	Compliance level	Guidance
b. The electric field intensity should be less than 3 V/m through the frequency range from 150 kHz through 80 MHz.			

<Recommended Separation Distance Between Portable and Mobile RF Communications Equipment and this Product>

Table 8

Recommended separation distance for portable and mobile RF communications equipment and this equipment.

This device is intended for use in electromagnetic environments in which emission RF interference is managed.

To control electromagnetic interference, the customer and user of this product can maintain the minimum distance between the following recommended portable and mobile RF communications equipment (transmitters) and this product based on the maximum output of the transmitter.

Rated maximum output power of transmitter P (W)	Separation distance related to frequency of the transmitter (m)		
	150kHz to 80MHz $d=1.2\sqrt{P}$	80 MHz to 800MHz $d=1.2\sqrt{P}$	800MHz to 2.5GHz $d=2.3\sqrt{P}$
0.01	0.12	0.12	0.23
0.1	0.38	0.38	0.73
1	1.2	1.2	2.3
10	3.8	3.8	7.3
100	12	12	23

For transmitters with a maximum output electric power rated value not listed above, the recommended separation distance (d) expressed in meters (m) can be determined using a formula that corresponds with the frequency of the transmitter. In these formulas, "P" is the maximum output power rating of the transmitter in watts (W) according to the transmitter manufacturer.

Note

- For 80 and 800 MHz, apply the higher frequency range for the separation distance.
- These guidelines do not apply to all circumstances. Electromagnetic propagation is affected by absorption and reflection by buildings, items, and people.

- Cables

Name	Maximum length	Specification
S Video cable	3m	Shielded cable with a characteristic impedance of 75Ω
Video cable	3m	Shielded cable with a characteristic impedance of 75Ω
RGB TV cable	3m	Shielded cable with a characteristic impedance of 75Ω (R, G, B, Sync)
DVI-D cable *1	5m	Shielded cable with a differential signal characteristic impedance of 100Ω Cable compliant with the DVI standard
LAN cable		Cat5e or higher, UTP type and straight cable
WC-LINK cable		Supplied with this product

Use the cable supplied with the printer to connect this product to the digital printer.

*1 Use the cable supplied with the monitor.

11.3 Software Used in This Product

(1) GPL

This product uses the software based on GNU General Public License (hereinafter called GPL).

Note

- GPL is the free software license advocated by GNU project.
Permission to use, copy, modify and redistribute the GPL software is granted without fee.
For distribution and copy of this software, the source program should be provided.

If you would like the source program of this software, contact the sales agent from whom you purchased this product or our service representatives. It will be provided at actual cost. Note that you will be provided with only the free software based on GPL in the software of which this product consists. The software developed and created independently for this product is excluded.

<Definition of Software License Used in This Product>

Free-Type2

This software is based in part of the work of FreeType Team.

HarfBuzz

This software is based in part of the work of FreeType Team.

libjpeg

This software is based in part on the work of the Independent JPEG Group.

libtiff

Copyright (c) 1988-1997 Sam Leffler
Copyright (c) 1991-1997 Silicon Graphics, Inc.

Permission to use, copy, modify, distribute, and sell this software and its documentation for any purpose is hereby granted without fee, provided that (i) the above copyright notices and this permission notice appear in all copies of the software and related documentation, and (ii) the names of Sam Leffler and Silicon Graphics may not be used in any advertising or publicity relating to the software without the specific, prior written permission of Sam Leffler and Silicon Graphics.

THE SOFTWARE IS PROVIDED "AS-IS" AND WITHOUT WARRANTY OF ANY KIND, EXPRESS, IMPLIED OR OTHERWISE, INCLUDING WITHOUT LIMITATION, ANY WARRANTY OF MERCHANTABILITY OR FITNESS FOR A PARTICULAR PURPOSE. IN NO EVENT SHALL SAM LEFFLER OR SILICON GRAPHICS BE LIABLE FOR ANY SPECIAL, INCIDENTAL, INDIRECT OR CONSEQUENTIAL DAMAGES OF ANY KIND, OR ANY DAMAGES WHATSOEVER RESULTING FROM LOSS OF USE, DATA OR PROFITS, WHETHER OR NOT ADVISED OF THE POSSIBILITY OF DAMAGE, AND ON ANY THEORY OF LIABILITY, ARISING OUT OF OR IN CONNECTION WITH THE USE OR PERFORMANCE OF THIS SOFTWARE.

DCMTK
COPYRIGHT

Unless otherwise specified, the DCMTK software package has the following copyright:

```
/*
 * Copyright (C) 1994-2011, OFFIS e.V.
 * All rights reserved.
 *
 * This software and supporting documentation were developed by
 *
 * OFFIS e.V.
 * R&D Division Health
 * Escherweg 2
 * 26121 Oldenburg, Germany
 *
 * Redistribution and use in source and binary forms, with or without
 * modification, are permitted provided that the following conditions
 * are met:
 *
 * - Redistributions of source code must retain the above copyright
 * notice, this list of conditions and the following disclaimer.
 *
 * - Redistributions in binary form must reproduce the above copyright
 * notice, this list of conditions and the following disclaimer in the
 * documentation and/or other materials provided with the distribution.
 *
 * - Neither the name of OFFIS nor the names of its contributors may be
 * used to endorse or promote products derived from this software
 * without specific prior written permission.
 *
 * THIS SOFTWARE IS PROVIDED BY THE COPYRIGHT HOLDERS AND CONTRIBUTORS
 * "AS IS" AND ANY EXPRESS OR IMPLIED WARRANTIES, INCLUDING, BUT NOT
 * LIMITED TO, THE IMPLIED WARRANTIES OF MERCHANTABILITY AND FITNESS FOR
 * A PARTICULAR PURPOSE ARE DISCLAIMED. IN NO EVENT SHALL THE COPYRIGHT
 * HOLDER OR CONTRIBUTORS BE LIABLE FOR ANY DIRECT, INDIRECT, INCIDENTAL,
 * SPECIAL, EXEMPLARY, OR CONSEQUENTIAL DAMAGES (INCLUDING, BUT NOT
 * LIMITED TO, PROCUREMENT OF SUBSTITUTE GOODS OR SERVICES; LOSS OF USE,
 * DATA, OR PROFITS; OR BUSINESS INTERRUPTION) HOWEVER CAUSED AND ON ANY
 * THEORY OF LIABILITY, WHETHER IN CONTRACT, STRICT LIABILITY, OR TORT
 * (INCLUDING NEGLIGENCE OR OTHERWISE) ARISING IN ANY WAY OUT OF THE USE
 * OF THIS SOFTWARE, EVEN IF ADVISED OF THE POSSIBILITY OF SUCH DAMAGE.
 */
```

Please note that some DCMTK modules, especially those that are not part of the free toolkit, are covered by a separate license which can be found in the COPYRIGHT file in the corresponding module directory. Some portions of the DCMTK software package are derived from earlier versions of this software with the following copyright, and can be identified by the following copyright notice located in each source file:

```
/*
 * Copyright (C) 1993/1994, OFFIS, Oldenburg University and CERIUUM
 *
 * This software and supporting documentation were
 * developed by
 *
 * Institut OFFIS
 * Bereich Kommunikationssysteme
 * Westerstr. 10-12
 * 26121 Oldenburg, Germany
 *
 * Fachbereich Informatik
 * Abteilung Prozessinformatik
 * Carl von Ossietzky Universitaet Oldenburg
 * Ammerlaender Heerstr. 114-118
 * 26111 Oldenburg, Germany
 *
 * CERIUUM
 * Laboratoire SIM
 * Faculte de Medecine
 * 2 Avenue du Pr. Leon Bernard
 * 35043 Rennes Cedex, France
 *
 * for CEN/TC251/WG4 as a contribution to the Radiological
 * Society of North America (RSNA) 1993 Digital Imaging and
 * Communications in Medicine (DICOM) Demonstration.
 */
```

```
* THIS SOFTWARE IS MADE AVAILABLE, AS IS, AND NEITHER OFFIS,
 * OLDENBURG UNIVERSITY NOR CERIUUM MAKE ANY WARRANTY REGARDING
 * THE SOFTWARE, ITS PERFORMANCE, ITS MERCHANTABILITY OR
 * FITNESS FOR ANY PARTICULAR USE, FREEDOM FROM ANY COMPUTER
 * DISEASES OR ITS CONFORMITY TO ANY SPECIFICATION. THE
 * ENTIRE RISK AS TO QUALITY AND PERFORMANCE OF THE SOFTWARE
 * IS WITH THE USER.
```

```
* Copyright of the software and supporting documentation
 * is, unless otherwise stated, jointly owned by OFFIS,
 * Oldenburg University and CERIUUM and free access is hereby
 * granted as a license to use this software, copy this
 * software and prepare derivative works based upon this
 * software. However, any distribution of this software
 * source code or supporting documentation or derivative
 * works (source code and supporting documentation) must
 * include the three paragraphs of this copyright notice.
```

```
*/
Some other parts of this software within the dcmtk/dcmnet sub-package
related to the DICOM Upper Layer Protocol are derived from software
developed for the RSNA'93 DICOM demonstration and kindly made available
to us by the Mallinckrodt Institute of Radiology. Such software can be
identified by the following copyright notice located in each affected
source file:
```

```
/*
 * Copyright (C) 1993, RSNA and Washington University
 *
 * The software and supporting documentation for the Radiological
 * Society of North America (RSNA) 1993 Digital Imaging and
 * Communications in Medicine (DICOM) Demonstration were developed
 * at the
 *
 * Electronic Radiology Laboratory
 * Mallinckrodt Institute of Radiology
 * Washington University School of Medicine
 * 510 S. Kingshighway Blvd.
 * St. Louis, MO 63110
 *
 * as part of the 1993 DICOM Central Test Node project for, and
 * under contract with, the Radiological Society of North America.
```

```
* THIS SOFTWARE IS MADE AVAILABLE, AS IS, AND NEITHER RSNA NOR
 * WASHINGTON UNIVERSITY MAKE ANY WARRANTY ABOUT THE SOFTWARE, ITS
 * PERFORMANCE, ITS MERCHANTABILITY OR FITNESS FOR ANY PARTICULAR
 * USE, FREEDOM FROM ANY COMPUTER DISEASES OR ITS CONFORMITY TO ANY
 * SPECIFICATION. THE ENTIRE RISK AS TO QUALITY AND PERFORMANCE OF
 * THE SOFTWARE IS WITH THE USER.
```

```
* Copyright of the software and supporting documentation is
 * jointly owned by RSNA and Washington University, and free access
 * is hereby granted as a license to use this software, copy this
 * software and prepare derivative works based upon this software.
 * However, any distribution of this software source code or
 * supporting documentation or derivative works (source code and
 * supporting documentation) must include the three paragraphs of
 * the copyright notice.
```

```
*/
The code for the OFStandard::strncpy and OFStandard::strcat helper
functions in ofstd/libsrc/ofstd.cc has been derived from the BSD
implementation of strncpy() and strcat() and which carries the
following copyright notice:
```

```
/*
 * Copyright (c) 1998 Todd C. Miller <Todd.Miller(at)courtesan.com>
 * All rights reserved.
 *
 * Redistribution and use in source and binary forms, with or without
 * modification, are permitted provided that the following conditions
 * are met:
 *
 * 1. Redistributions of source code must retain the above copyright
 * notice, this list of conditions and the following disclaimer.
 *
 * 2. Redistributions in binary form must reproduce the above copyright
 * notice, this list of conditions and the following disclaimer in the
 * documentation and/or other materials provided with the distribution.
 *
 * 3. The name of the author may not be used to endorse or promote products
 * derived from this software without specific prior written permission.
 */
```

```

* THIS SOFTWARE IS PROVIDED ``AS IS" AND ANY EXPRESS OR IMPLIED WARRANTIES,
* INCLUDING, BUT NOT LIMITED TO, THE IMPLIED WARRANTIES OF MERCHANTABILITY
* AND FITNESS FOR A PARTICULAR PURPOSE ARE DISCLAIMED. IN NO EVENT SHALL
* THE AUTHOR BE LIABLE FOR ANY DIRECT, INDIRECT, INCIDENTAL, SPECIAL,
* EXEMPLARY, OR CONSEQUENTIAL DAMAGES (INCLUDING, BUT NOT LIMITED TO,
* PROCUREMENT OF SUBSTITUTE GOODS OR SERVICES; LOSS OF USE, DATA, OR PROFITS;
* OR BUSINESS INTERRUPTION) HOWEVER CAUSED AND ON ANY THEORY OF LIABILITY,
* WHETHER IN CONTRACT, STRICT LIABILITY, OR TORT (INCLUDING NEGLIGENCE OR
* OTHERWISE) ARISING IN ANY WAY OUT OF THE USE OF THIS SOFTWARE, EVEN IF
* ADVISED OF THE POSSIBILITY OF SUCH DAMAGE.
*/

```

The code for the OFStandard::atof helper function in ofstd/libsrc/ofstd.cc has been derived from an implementation which carries the following copyright notice:

```

/*
 * Copyright 1988 Regents of the University of California
 * Permission to use, copy, modify, and distribute this software and
 * its documentation for any purpose and without fee is hereby granted,
 * provided that the above copyright notice appear in all copies. The
 * University of California makes no representations about the
 * suitability of this software for any purpose. It is provided "as
 * is" without express or implied warranty.
 *
 *
 * The code for OFStandard::ftoa has been derived
 * from an implementation which carries the following copyright notice:
 *
 * Copyright (c) 1988 Regents of the University of California.
 * All rights reserved.
 *
 * Redistribution and use in source and binary forms are permitted
 * provided that the above copyright notice and this paragraph are
 * duplicated in all such forms and that any documentation,
 * advertising materials, and other materials related to such
 * distribution and use acknowledge that the software was developed
 * by the University of California, Berkeley. The name of the
 * University may not be used to endorse or promote products derived
 * from this software without specific prior written permission.
 * THIS SOFTWARE IS PROVIDED ``AS IS" AND WITHOUT ANY EXPRESS OR
 * IMPLIED WARRANTIES, INCLUDING, WITHOUT LIMITATION, THE IMPLIED
 * WARRANTIES OF MERCHANTABILITY AND FITNESS FOR A PARTICULAR PURPOSE.
 */

```

The "Base64" encoder/decoder in ofstd/libsrc/ofstd.cc has been derived from an implementation which carries the following copyright notice:

```

/*
 * Copyright (c) 1999, Bob Withers - bwit(at)pobox.com
 *
 * This code may be freely used for any purpose, either personal or commercial,
 * provided the authors copyright notice remains intact.
 */

```

(2) Eclipse

This product uses the software based on Eclipse Public License 1.0 and Eclipse Distribution License 1.0.

If you would like the source program of this software, contact the sales agent from whom you purchased this product or our service representatives. It will be provided at actual cost. Note that you will be provided with only the open source software in the software of which this product consists. The software developed and created independently for this product is excluded.

<Definition of Software License Used in This Product>

Eclipse Paho MQTT C client
Copyright IBM Corp. 2009, 2017

Eclipse Distribution License - v 1.0

Copyright (c) 2007, Eclipse Foundation, Inc. and its licensors.

All rights reserved.

Redistribution and use in source and binary forms, with or without modification, are permitted provided that the following conditions are met:

Redistributions of source code must retain the above copyright notice, this list of conditions and the following disclaimer.

Redistributions in binary form must reproduce the above copyright notice, this list of conditions and the following disclaimer in the documentation and/or other materials provided with the distribution.

Neither the name of the Eclipse Foundation, Inc. nor the names of its contributors may be used to endorse or promote products derived from this software without specific prior written permission.

THIS SOFTWARE IS PROVIDED BY THE COPYRIGHT HOLDERS AND CONTRIBUTORS "AS IS" AND ANY EXPRESS OR IMPLIED WARRANTIES, INCLUDING, BUT NOT LIMITED TO, THE IMPLIED WARRANTIES OF MERCHANTABILITY AND FITNESS FOR A PARTICULAR PURPOSE ARE DISCLAIMED. IN NO EVENT SHALL THE COPYRIGHT OWNER OR CONTRIBUTORS BE LIABLE FOR ANY DIRECT, INDIRECT, INCIDENTAL, SPECIAL, EXEMPLARY, OR CONSEQUENTIAL DAMAGES (INCLUDING, BUT NOT LIMITED TO, PROCUREMENT OF SUBSTITUTE GOODS OR SERVICES; LOSS OF USE, DATA, OR PROFITS; OR BUSINESS INTERRUPTION) HOWEVER CAUSED AND ON ANY THEORY OF LIABILITY, WHETHER IN CONTRACT, STRICT LIABILITY, OR TORT (INCLUDING NEGLIGENCE OR OTHERWISE) ARISING IN ANY WAY OUT OF THE USE OF THIS SOFTWARE, EVEN IF ADVISED OF THE POSSIBILITY OF SUCH DAMAGE.

(3) msgpack-c

Boost Software License - Version 1.0 - August 17th, 2003

Permission is hereby granted, free of charge, to any person or organization obtaining a copy of the software and accompanying documentation covered by this license (the "Software") to use, reproduce, display, distribute, execute, and transmit the Software, and to prepare derivative works of the Software, and to permit third-parties to whom the Software is furnished to do so, all subject to the following:

The copyright notices in the Software and this entire statement, including the above license grant, this restriction and the following disclaimer, must be included in all copies of the Software, in whole or in part, and all derivative works of the Software, unless such copies or derivative works are solely in the form of machine-executable object code generated by a source language processor.

THE SOFTWARE IS PROVIDED "AS IS", WITHOUT WARRANTY OF ANY KIND, EXPRESS OR IMPLIED, INCLUDING BUT NOT LIMITED TO THE WARRANTIES OF MERCHANTABILITY, FITNESS FOR A PARTICULAR PURPOSE, TITLE AND NON-INFRINGEMENT. IN NO EVENT SHALL THE COPYRIGHT HOLDERS OR ANYONE DISTRIBUTING THE SOFTWARE BE LIABLE FOR ANY DAMAGES OR OTHER LIABILITY, WHETHER IN CONTRACT, TORT OR OTHERWISE, ARISING FROM, OUT OF OR IN CONNECTION WITH THE SOFTWARE OR THE USE OR OTHER DEALINGS IN THE SOFTWARE.

(4) OpenSSL

LICENSE ISSUES

=====

The OpenSSL toolkit stays under a double license, i.e. both the conditions of the OpenSSL License and the original SSLeay license apply to the toolkit. See below for the actual license texts.

OpenSSL License

```
/* =====
```

```
* Copyright (c) 1998-2018 The OpenSSL Project. All rights reserved.
```

```
*
```

```
* Redistribution and use in source and binary forms, with or without
```

```
* modification, are permitted provided that the following conditions
```

```
* are met:
```

```
*
```

```
* 1. Redistributions of source code must retain the above copyright
```

```
* notice, this list of conditions and the following disclaimer.
```

```
*
```

```
* 2. Redistributions in binary form must reproduce the above copyright
```

```
* notice, this list of conditions and the following disclaimer in
```

```
* the documentation and/or other materials provided with the
```

```
* distribution.
```

```
*
```

```
* 3. All advertising materials mentioning features or use of this
```

```
* software must display the following acknowledgment:
```

```
* "This product includes software developed by the OpenSSL Project
```

```
* for use in the OpenSSL Toolkit. (http://www.openssl.org/)"
```

```
*
```

```
* 4. The names "OpenSSL Toolkit" and "OpenSSL Project" must not be used to
```

```
* endorse or promote products derived from this software without
```

```
* prior written permission. For written permission, please contact
```

```
* openssl-core@openssl.org.
```

```
*
```

```
* 5. Products derived from this software may not be called "OpenSSL"
```

```
* nor may "OpenSSL" appear in their names without prior written
```

```
* permission of the OpenSSL Project.
```

```
*
```

```
* 6. Redistributions of any form whatsoever must retain the following
```

```
* acknowledgment:
```

```
* "This product includes software developed by the OpenSSL Project
```

```
* for use in the OpenSSL Toolkit (http://www.openssl.org/)"
```

```
*
```

```

* THIS SOFTWARE IS PROVIDED BY THE OpenSSL PROJECT ``AS IS'' AND ANY
* EXPRESSED OR IMPLIED WARRANTIES, INCLUDING, BUT NOT LIMITED TO, THE
* IMPLIED WARRANTIES OF MERCHANTABILITY AND FITNESS FOR A PARTICULAR
* PURPOSE ARE DISCLAIMED. IN NO EVENT SHALL THE OpenSSL PROJECT OR
* ITS CONTRIBUTORS BE LIABLE FOR ANY DIRECT, INDIRECT, INCIDENTAL,
* SPECIAL, EXEMPLARY, OR CONSEQUENTIAL DAMAGES (INCLUDING, BUT
* NOT LIMITED TO, PROCUREMENT OF SUBSTITUTE GOODS OR SERVICES;
* LOSS OF USE, DATA, OR PROFITS; OR BUSINESS INTERRUPTION)
* HOWEVER CAUSED AND ON ANY THEORY OF LIABILITY, WHETHER IN CONTRACT,
* STRICT LIABILITY, OR TORT (INCLUDING NEGLIGENCE OR OTHERWISE)
* ARISING IN ANY WAY OUT OF THE USE OF THIS SOFTWARE, EVEN IF ADVISED
* OF THE POSSIBILITY OF SUCH DAMAGE.

```

```

* =====

```

```

*

```

```

* This product includes cryptographic software written by Eric Young
* (eay@cryptsoft.com). This product includes software written by Tim
* Hudson (tjh@cryptsoft.com).

```

```

*

```

```

*/

```

Original SSLeay License

```

-----

```

```

/* Copyright (C) 1995-1998 Eric Young (eay@cryptsoft.com)

```

```

* All rights reserved.

```

```

*

```

```

* This package is an SSL implementation written

```

```

* by Eric Young (eay@cryptsoft.com).

```

```

* The implementation was written so as to conform with Netscapes SSL.

```

```

*

```

```

* This library is free for commercial and non-commercial use as long as

```

```

* the following conditions are aheared to. The following conditions

```

```

* apply to all code found in this distribution, be it the RC4, RSA,

```

```

* lhash, DES, etc., code; not just the SSL code. The SSL documentation

```

```

* included with this distribution is covered by the same copyright terms

```

```

* except that the holder is Tim Hudson (tjh@cryptsoft.com).

```

```

*

```

```

* Copyright remains Eric Young's, and as such any Copyright notices in

```

```

* the code are not to be removed.

```

```

* If this package is used in a product, Eric Young should be given attribution

```

```

* as the author of the parts of the library used.

```

```

* This can be in the form of a textual message at program startup or

```

```

* in documentation (online or textual) provided with the package.

```

```

*

```

```

* Redistribution and use in source and binary forms, with or without

```

```

* modification, are permitted provided that the following conditions

```

```

* are met:

```

- * 1. Redistributions of source code must retain the copyright notice, this list of conditions and the following disclaimer.
- * 2. Redistributions in binary form must reproduce the above copyright notice, this list of conditions and the following disclaimer in the documentation and/or other materials provided with the distribution.
- * 3. All advertising materials mentioning features or use of this software must display the following acknowledgement:
 - * "This product includes cryptographic software written by Eric Young (eay@cryptsoft.com)"
 - * The word 'cryptographic' can be left out if the routines from the library being used are not cryptographic related :-).
- * 4. If you include any Windows specific code (or a derivative thereof) from the apps directory (application code) you must include an acknowledgement:
 - * "This product includes software written by Tim Hudson (tjh@cryptsoft.com)"
 - *
 - * THIS SOFTWARE IS PROVIDED BY ERIC YOUNG ``AS IS'' AND
 - * ANY EXPRESS OR IMPLIED WARRANTIES, INCLUDING, BUT NOT LIMITED TO, THE
 - * IMPLIED WARRANTIES OF MERCHANTABILITY AND FITNESS FOR A PARTICULAR PURPOSE
 - * ARE DISCLAIMED. IN NO EVENT SHALL THE AUTHOR OR CONTRIBUTORS BE LIABLE
 - * FOR ANY DIRECT, INDIRECT, INCIDENTAL, SPECIAL, EXEMPLARY, OR CONSEQUENTIAL
 - * DAMAGES (INCLUDING, BUT NOT LIMITED TO, PROCUREMENT OF SUBSTITUTE GOODS
 - * OR SERVICES; LOSS OF USE, DATA, OR PROFITS; OR BUSINESS INTERRUPTION)
 - * HOWEVER CAUSED AND ON ANY THEORY OF LIABILITY, WHETHER IN CONTRACT, STRICT
 - * LIABILITY, OR TORT (INCLUDING NEGLIGENCE OR OTHERWISE) ARISING IN ANY WAY
 - * OUT OF THE USE OF THIS SOFTWARE, EVEN IF ADVISED OF THE POSSIBILITY OF
 - * SUCH DAMAGE.
- * The licence and distribution terms for any publically available version or derivative of this code cannot be changed. i.e. this code cannot simply be copied and put under another distribution licence
 - * [including the GNU Public Licence.]
- */

11.4 After-Sales Service

- (1) If the equipment does not work properly, check it first by reading this manual again and follow all instructions.
- (2) If the equipment is still not working well, contact your local FUJIFILM dealer.
- (3) Repairs during the warranty period

We will repair your equipment free of charge according to the provisions of the warranty. The warranty period is one year after date of purchase.

Note that the warranty is void in the following cases:

- a. Damage caused by fire or natural disaster such as storms or floods.
- b. Trouble caused by careless handling or misuse of the product on the part of the user.
- c. Trouble caused by repair or modification by an unauthorized person.

- (4) Repairs after the warranty period

We will make a paid repair at your request if the equipment is found possible to restore the normal function by repair.

When contacting your local FUJIFILM dealer, provide the following information.

Model name: EP-6000

Serial number:

Description of failure: as detailed as possible

Date of purchase:

Note

- The serial number is indicated on the left-hand side of the rear panel.

<Product Malfunction>

In case of product malfunction, consult your local FUJIFILM dealer. The product will be repaired at the factory or replaced with a comparable product.

11.5 Disposal of Electric and Electronic Equipment



Disposal of Used Electrical and Electronic Equipment (Applicable in the European Union and other European countries with separate collection systems)

This symbol on the product, or in the manual and/or on this packaging, indicates that this product shall not be treated as household waste.

Instead it should be taken to an applicable collection point for the recycling of electrical and electronic equipment.

By ensuring this product is disposed of correctly, you will help prevent potential negative consequences to the environment and human health, which could otherwise be caused by inappropriate waste handling of this product.

The recycling of materials will help to conserve natural resources. For more detailed information about recycling of this product, contact your local FUJIFILM dealer.

In Countries outside the EU: If you wish to discard this product, contact your local authorities and ask for the correct way of disposal.

11.6 Index

Numerical

- 600 System Scope and 500 System Scope.... 7-6
- 700 System Scope..... 7-5

A

- After-Sales Service 11-24
- Age..... 3-16, 3-19
- Air Supply Indicator..... 3-1
- Air/water nozzle 6-6
- Air/water valve 6-6
- Applied Part 11-1

B

- [Backspace] key 3-8
- Block Diagram..... 11-5
- Brightness Adjustment Button..... 3-2

C

- [Caps Lock] key 3-9
- Care after Use of Processor 9-1
- [Case] key 3-7
- Caution Label..... 3-10
- Classification of Medical Electrical
Equipment..... 11-1
- Color Printer..... 8-1, 8-6
- Communication Window (LED)..... 3-3
- Contour Emphasis 3-19

D

- Data control keys 3-7
- Data Keyboard 2-2
- [Data Off/Space] key..... 3-9
- Date 3-15, 3-20
- Date of Birth 3-16, 3-19
- [Delete] key 3-8
- DICOM Server Connection Status 3-17
- Digital Printer 8-9
- Digital Printer Connector..... 3-5
- Disposal of Electric and Electronic
Equipment..... 11-25
- [Doctor] key..... 3-7
- Doctor list..... 4-54

- Doctor Name 3-17, 3-19
- Dustproof Filter..... 3-6
- DVI-D Connector 3-4

E

- Electrical Connector Socket 3-3, 7-7
- Electromagnetic Compatibility (EMC)
Information 11-6
- Electronic Zoom Ratio 3-16
- Electrosurgical Unit 4-20
- Endoscope 2-2
- [Enter] key 3-8
- EP-6000 4-22
- Equipment Using in Combination..... 2-2
- Error Messages 10-6
- [Esc] key..... 3-9
- EXAM. Button..... 3-2
- EXAM. Indicator Lamp 3-2
- External Storage Device 8-19

F

- FICE 3-19
- [FICE] key 3-8
- FICE Set..... 3-21, 3-22
- Focus Indicator..... 3-16, 3-19
- Foot Switch Connector..... 3-5
- Freeze Mode 5-58
- Front Panel..... 3-1
- Full HD mode 3-12
- Fuse Holder..... 3-4

H

- Hospital Name..... 3-16, 3-20
- Hyper-Tone and Noise Reduction..... 3-17, 3-19

I

- [Image] key..... 3-7
- Image Setup Page 3-16, 5-48
- Index 5-57
- Indicator 3-2
- Input/Output Connector..... 11-4
- [Insert] key..... 3-8

Internal and External Storage Devices..	8-16, 8-25
Iris Mode	3-15, 3-19
Iris Mode Button	3-3

K

Keyboard.....	3-7, 9-2
Keyboard Connector	3-5

L

Lap Time	7-24
LCD Monitor	2-2
LG connector	7-6
Light Button.....	3-2
Light Mode Button	3-3
Light Source	7-9
Live image.....	3-13
Login	3-16
Louver	3-6

M

Medical Device Directive	11-5
Memory Access Lamp	3-3
Memory Slot.....	3-3
[Message] key	3-7
Message List.....	4-63
[Move PinP/Tab] key	3-9
MULTI Button	3-3
[Multi] key	3-7
Multi Zoom Mode	5-60

N

Network Access Indicator Lamp	3-2
Network Connector	3-5
Noise Reduction.....	3-17, 3-19
[Note] key	3-7
Number of Captured Images.....	3-17
Number of Recordable Images in Internal Storage Device	3-17

O

ON Indicator	3-1
Operating Environment	11-4
Other keys.....	3-8

P

[PageUp] key.....	3-8
[Panel] key	3-8
[Patient Entry] key	3-7
Patient ID or Examination No.....	3-16, 3-19
Patient Info. + Scope Info.....	3-23
Patient Information	6-7
Patient Information Entry screen.....	5-8
[Patient] key	3-7
Patient Name	3-16, 3-19
Peripheral device control keys	3-7
[Peripherals] key	3-7
Potential Equalization Terminal.....	3-4
Power Button.....	3-2
Power Indicator Lamp	3-2
Power Supply Connector	3-4
Power Supply Section	3-3
Printer.....	2-2
Printer Status	3-17
procedure list.....	4-59
Procedure or Comment.....	3-17, 3-20
Processor	2-1, 2-2
Pump Button	3-1

R

R, G and B Components	3-17
R, G and B Gain Levels	3-17
R, G and B Wavelengths.....	3-22
Rating Plate.....	3-10
Reader Connector.....	3-5
Rear Panel	3-4
Receiving Window.....	3-3
Registering and Calling Adjustment Value	6-7
Relocation	9-6
Remote Connector 1	3-5
Remote Connector 2	3-5
RGB gain level	3-22
RGB TV Connector	3-4
RS-232C Connector 1	3-5
RS-232C Connector 2	3-5

S

S Video Connector	3-4
Scope Connector Socket	3-1

Scope Information	3-17	Water tank hook	3-6
Scope socket	7-5	WC-LINK cable terminal	3-4
[Search] key	3-8		
Sex	3-16, 3-19		
Shutter Speed	3-16, 3-19		
Side Panel	3-6		
Socket Protection Cap	3-10		
Software	11-16		
Special Light Observation Mode	3-16, 3-20		
Specification	11-1		
Spectral Image Processing function	3-16		
Standard System Configuration	2-4		
[Start] key	3-8		
Starting the Examination	7-25		
Storage	9-5		
Structure Emphasis	3-17, 3-19		
Supplying Power to the Equipment	7-8		
Switch Setting	3-16		
SXGA mode	3-12		
Symbols	3-11		
System Expansion	2-6		
[System] key	3-7		

T

Term of Validity/Period for Use (Durability)...	11-4
Time	3-15, 3-20
Timer	3-15, 3-20, 7-22
[Timer Ctrl] key	3-9
Tone	3-17, 3-19
Transport and Storage Environment	11-4
[Trigger] key	3-8
Troubleshooting	10-1

U

Ultrasonic Processor	2-2
----------------------------	-----

V

Ventilation Holes	3-4, 3-6
Video Connector	3-4
Video output screen	3-18
Video Recorder	2-2, 8-13, 8-15

W

Water Tank	2-2, 7-6
------------------	----------

Service Center

Contact our regional representative below or the distributor from which you purchased the product.

<Europe>

FUJIFILM Europe GmbH

<http://www.fujifilm.eu/eu/>

See our website to locate our representative in your country.

<USA>

Fujifilm Medical Systems U.S.A., Inc

<http://www.fujifilmendoscopy.com/>

(800) 385-4666

<Australia>

FUJIFILM Australia Pty Ltd

<http://www.fujifilm.com.au/>

1800 060 209

<Asia>

FUJIFILM Asia Pacific Pte. Ltd.

<http://www.fujifilm.com.sg/>

6380-5540

If you are not a resident of the regions above, contact the distributor from which you purchased the product.



FUJIFILM Corporation

26-30, Nishiazabu 2-chome, Minato-ku, Tokyo 106-8620, Japan



FUJIFILM Europe GmbH

Heesenstrasse 31, 40549 Duesseldorf, Germany

EU Importer:

FUJIFILM Europe B.V.

Oudenstaart 1, 5047 TK Tilburg, The Netherlands

Imported to Australia by:

FUJIFILM Australia Pty Ltd

114 Old Pittwater Road, Brookvale, NSW. 2100, Australia