

KaVo Imaging

DENTAL
EX
CE
LLEN
CE

KAVO
Dental Excellence

KaVo Imaging –
The next generation
of dental excellence.

CONTENTS

04	Dental Excellence	
	Brand Promise	04
	KaVo 360°	
	Portfolio	06
	Stronger together	08
	Interview	10
	KaVo Imaging Portfolio	14
14	Intraoral	
	KaVo ProXam iX	18
	KaVo ProXam iS	22
	KaVo ProXam iP	26
	KaVo ProXam iOS	30
34	Extraoral	
	KaVo ProXam 2D series	38
	KaVo ProXam 3D series	44
	Ceph imaging	52
50	Software	
	Romexis	56
60	Service	
	KaVo Maintenance	71
	Service quality	73
	Technical data	74
	Index	94



KaVo Dental Excellence Brand Promise

What we stand for as a brand

KaVo is a long-established, dependable manufacturer, and always will be. We and our products have stood for the highest quality and reliability for over 100 years, so our customers can concentrate on what's important.

KaVo is a long-established, dependable manufacturer, and always will be. We and our products have stood for the highest quality and reliability for over 100 years, so our customers can concentrate on what's important. Thanks to our perfect interplay of dynamism and expertise, we're always at the cutting edge.



Dental units



Instruments



Imaging



Dental training

Portfolio Statements



Dental units

KaVo dental units - Invest in your own health.

KaVo dental units are your dependable practice partner.

KaVo dental units are unrivalled when it comes to promoting a natural posture with exceptional freedom of movement and short reach distances. They provide the ideal ergonomic solution for every conceivable treatment situation.

We aim to combine the highest standards of hygiene with an aesthetic design to create a feel-good atmosphere for users and patients alike. This perfectly harmonised package for the dental workplace includes a long service life and absolute reliability - Made in Germany.



Instruments

KaVo instruments - Feel the difference.

Our instruments are based on the finest materials, developed exclusively for our products.

These are paired with our unique product architecture - fabricated from solid workpieces - for extraordinary precision and durability.

We set the standard for the dental instruments of today. This wealth of experience, borne of over a century of constant innovation, is reflected in the design and functionality of our current instruments. The result is optimum user performance through precise, fatigue-free working.



Imaging

KaVo Imaging - See more, plan better

The combination of 35+ years of experience in the development of imaging systems, and the innovative strength of an owner-managed family business form the basis for our KaVo ProXam X-ray portfolio in both the intra- and extraoral areas.

Perfectly tailored to the patient, we ensure the lowest possible radiation exposure with maximum clinical benefit and support fast, comfortable positioning with optimum accessibility. This most robust foundation, combined with high-tech components, brilliant image quality, a world-leading software platform with open interfaces and a broad sales and service network, all add up to a secure investment in your future.



Dental training

Dental training - Excellent learning

Our wealth of experience from over 100 years of innovation in the field of instruments and dental units and over 35 years in the of imaging systems form the basis for the highest quality training products.

With a flexible, customisable and functional portfolio, which we are continuously developing, we create the most accurate clinical training scenarios for dental students.

KaVo provides support with the conception, room design, configuration and realisation to perfect your ideas.

ONE PORTFOLIO – MANY POSSIBILITIES

KaVo 360° – Proficiency and excellence for modern dentistry.

As a pioneer in the dental industry, KaVo has been setting the pace in dentistry for over 110 years. Today, KaVo's preclinical portfolio and its products, including dental instruments, treatment units and

laboratory equipment, offer comprehensive proof of excellence for practices and clinics all over the world. KaVo products set the standards in the dental market, promoting innovation, quality, ergonomics and design.

KaVo is well on its way to becoming a complete solution provider and is now supplementing its existing product range with high-quality imaging solutions – the new KaVo ProXam series. This includes premium extraoral imaging, intraoral X-ray and scanning products. The central and all-networked, all-in-one Romexis software completes the KaVo imaging portfolio. In combination with Romexis, the ProXam products offer a particularly

compelling solution for dental practices and clinics looking to prepare for a digitised future while prioritising quality, reliability and premium service. Opting for the KaVo ProXam diagnostics concept offers customers a secure digital future and premium quality.

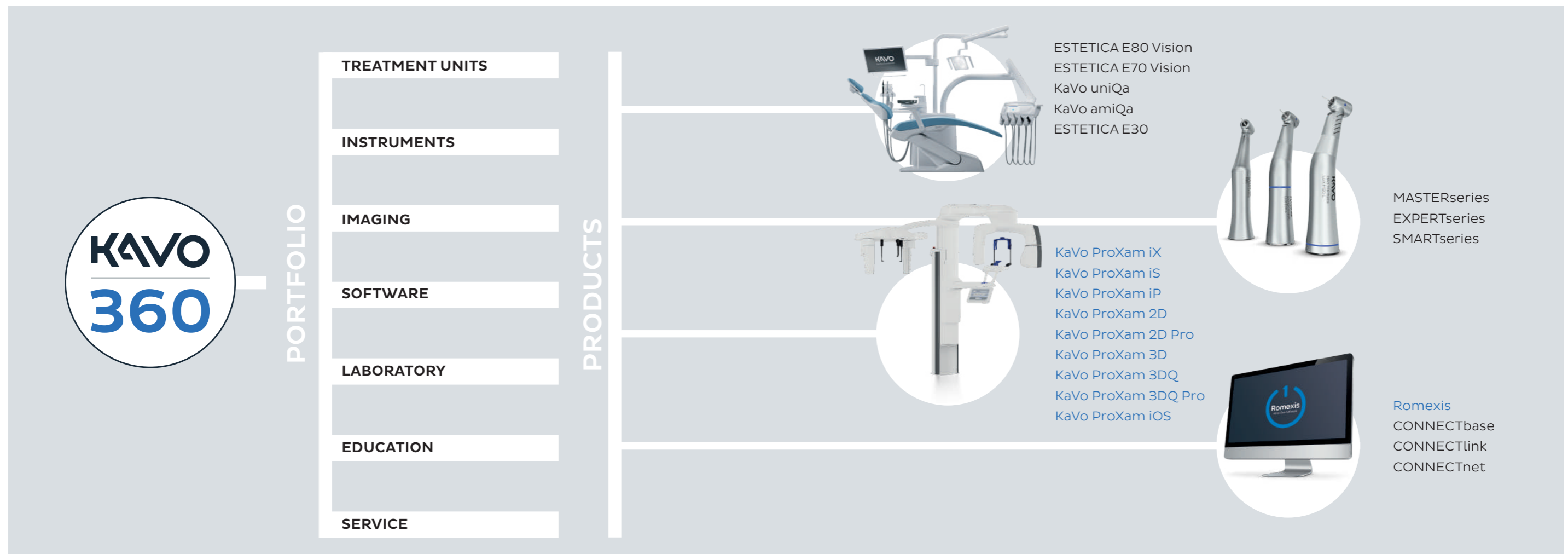

STRONGER TOGETHER

Two partners, one common goal:
The future of dental imaging is now.

KaVo ProXam – the name says it all.

KaVo ProXam also stands for a common approach and the streamlining of skills from two successful dental companies. The new name combines the well-known "Pro" from the Planmeca imaging products with the tradition of KaVo Imaging "Xam" naming. In this way, the new name honours both the quality and intelligence of the Planmeca units and KaVo's successful history of imaging diagnostics. The capitalised "X" in the middle of the name stands for X-ray technology. These KaVo naming elements will continue to appear in the field of imaging diagnostics at KaVo in the future.

KAVO
Dental Excellence



PLANMECA

4,500
employees
= one
family

KaVo and Planmeca, two leading companies on the international dental market, are combining their expertise in the field of dental imaging. This pooled knowledge, years of experience and a passion for modern dentistry have resulted in a KaVo imaging portfolio that sets imaging diagnostic standards. Both existing and new technologies, reliable high-quality imaging and new connectivity options are KaVo and

Planmeca's common goals. Accordingly, the new KaVo ProXam series calls on Planmeca's know-how to complement the KaVo product range. As part of the KaVo Planmeca product family, the Romexis all-in-one software is of course compatible with the relevant imaging units and ensures that all components can be networked intelligently and easily. This is the future of digital diagnostics.



JAN MOED INTERVIEW

KaVo and Planmeca are joining forces to offer new workflows in dental imaging.

Following the merger of the two industry giants KaVo and Planmeca, we are already seeing the first major expansion of the KaVo imaging portfolio. With its new KaVo ProXam imaging product series, the company based in Biberach, Germany, is wowing dental practices with its wealth of expertise, future-proof workflows and impressive features.

Jan Moed, CCO of KaVo new with global responsibility for marketing and sales.



Mr Moed, in March 2023 you introduced the ProXam range from KaVo. How was the new KaVo Imaging product range received by the target group? Could you give us a sense of the feedback from users?

Our ProXam Imaging series has been designed to provide the best solution to the daily challenges of dental diagnostics and to offer a range of options for a digital future. Our product portfolio directly addresses what dentists need in their practices today and in the future. This is reflected in the response to our products. Since its launch at the beginning of last year, our ProXam Imaging portfolio has met with great interest from our selected specialist dealers and our valued customers. When providing feedback, our customers regularly mention the intuitive

operation of our products and the all-in-one Romexis software. They also enthuse speak very positively about the high image quality and open interfaces. Customers describe our entire product portfolio, the support provided by our specialist dealers and our service team, and the training and the hotline support from our Biberach site as highly professional. We are committed to offering our customers superb service on an ongoing basis, together with our excellent products.

Can you outline for customers again what the ProXam portfolio consists of and what new things they can expect?

The Imaging portfolio is a premium product range for extraoral and intraoral imaging and intraoral scanning. As well as the imaging units themselves, we also offer our all-in-one Romexis software, which allows you to interconnect different units. Previously, KaVo's extraoral range consisted of three X-ray machines designed for the most exacting requirements. The KaVo ProXam 2D S2 (previously the KaVo ProXam 2D) was developed especially for 2D imaging requirements and includes programs for panoramic, extraoral bitewing, temporomandibular joint (TMJ) and sinus imaging. The KaVo ProXam 3D Classic (previously the KaVo ProXam 3D) and KaVo ProXam 3DQ Mid (previously the KaVo ProXam 3DQ) offer various intelligent 3D imaging programs. The new KaVo ProXam 2D S3 has also joined the product portfolio. Unlike the KaVo ProXam 2D S2, this features robot-controlled SCARA technology. The triple-jointed arm enables highly precise movements for anatomically correct image

geometry. For 3D requirements, we're rolling out the ProXam 3DQ Plus, which stands out from the rest primarily due to its maximum 3D volume size. All units can be expanded to include cephalometric X-rays, guaranteeing greater flexibility and future security. Existing highlights of these 3D units include the Ultra Low Dose and Calm modes. The effective radiation dose per patient can be reduced by an average of 77% in Ultra Low Dose mode – without any loss of image quality. CALM mode, meanwhile, eliminates the effects of patient movement. This is particularly useful when taking X-ray images of restless or lively patients such as children, people with special needs or elderly patients. However, the algorithm also benefits images across the board, as it improves quality. Ultra Low Dose mode and CALM can be used for all voxel sizes and all 3D images. The primary component of the intraoral KaVo ProXam portfolio is the KaVo ProXam iX X-ray tube, which can be positioned easily and precisely and ensures high-quality image results thanks to its focal point of just 0.4 mm. High image quality is also ensured by the KaVo ProXam iS intraoral X-ray sensors, which offer impressive handling when combined with the KaVo ProXam iX. The intraoral product range is completed by the KaVo ProXam iP, a compact, powerful imaging plate scanner, and the KaVo ProXam iOS, an intraoral scanner with a remarkable scanning speed and user-friendly features.

Experience has shown that people need X-ray software explaining to them. Are there prejudices or reservations that you repeatedly encounter in your day-to-day business?

Using our all-in-one Romexis software, which allows you to interconnect multiple units, represents a major step forward for any dental practice. The software can be adapted to the individual needs of dental practices and is highly intuitive to operate. Of course, some practices are still hesitant about switching require a little more persuading to switch from another brand to KaVo. As soon as dentists do decide to switch, we offer them dependable support from our selected dealers and qualified digital solutions specialists, who assist them as they advance into the future. This includes explaining our digital solutions.

The ProXam iCam has been part of KaVo's intraoral camera range since January of this year. Could you tell us more about the new product and how it interacts with others within the range?

The new KaVo ProXam iCam is a digital imaging diagnostic tool that can be connected directly to Romexis. It offers a high depth of field and superb user-friendliness is extremely user-friendly. The ProXam iCam is easy to operate with a button or foot control, and comes with a practical macro mode for close-ups. Its sharp intraoral images facilitate diagnostics, aid image documentation and

make patient communication that much easier. The ProXam iCam can be connected directly to the KaVo CONNECTbase and CONEXIO patient communication systems via interfaces, so diagnoses and treatment results can be discussed with the patient with direct reference to the image. The KaVo ProXam iCam enhances our range of intraoral cameras. Our DIAGNOcam Vision Full HD is also available with the Romexis software. The DIAGNOcam Vision Full HD* enables triple diagnostics using high-resolution intraoral images for initial visual diagnosis, in-depth insights into the tooth structure with transillumination technology, and informative fluorescence images. All three diagnostic images appear on your screen within one second, in full HD resolution.

Where does modern imaging stand today, and do you see any untapped potential for the future?

We follow the latest developments in digital technologies with great interest. Digital solutions are constantly being expanded, and we believe that the diagnostics of the future will soon be inconceivable without artificial intelligence. Actually, I have some exciting news on that very matter: The Romexis All-in-One software now comes with new modules, so our customers can now start using it with smart AI functions.

* For more information on the iCam and DIAGNOcam, see the bookazines on our instruments and dental units.



KaVo ProXam

One portfolio - many possibilities.



Find out more:
www.kavo.com/en/proxam

Choosing the KaVo ProXam concept means premium quality with proven, reliable technologies, whether in intraoral and extraoral imaging or in the field of intraoral scanning.

The KaVo ProXam all-in-one concept: **Highlights**

- Imaging units combined into one comprehensive software platform.
- A future-proof concept – a solution with excellent upgradeability.
- Reliability through proven technologies.

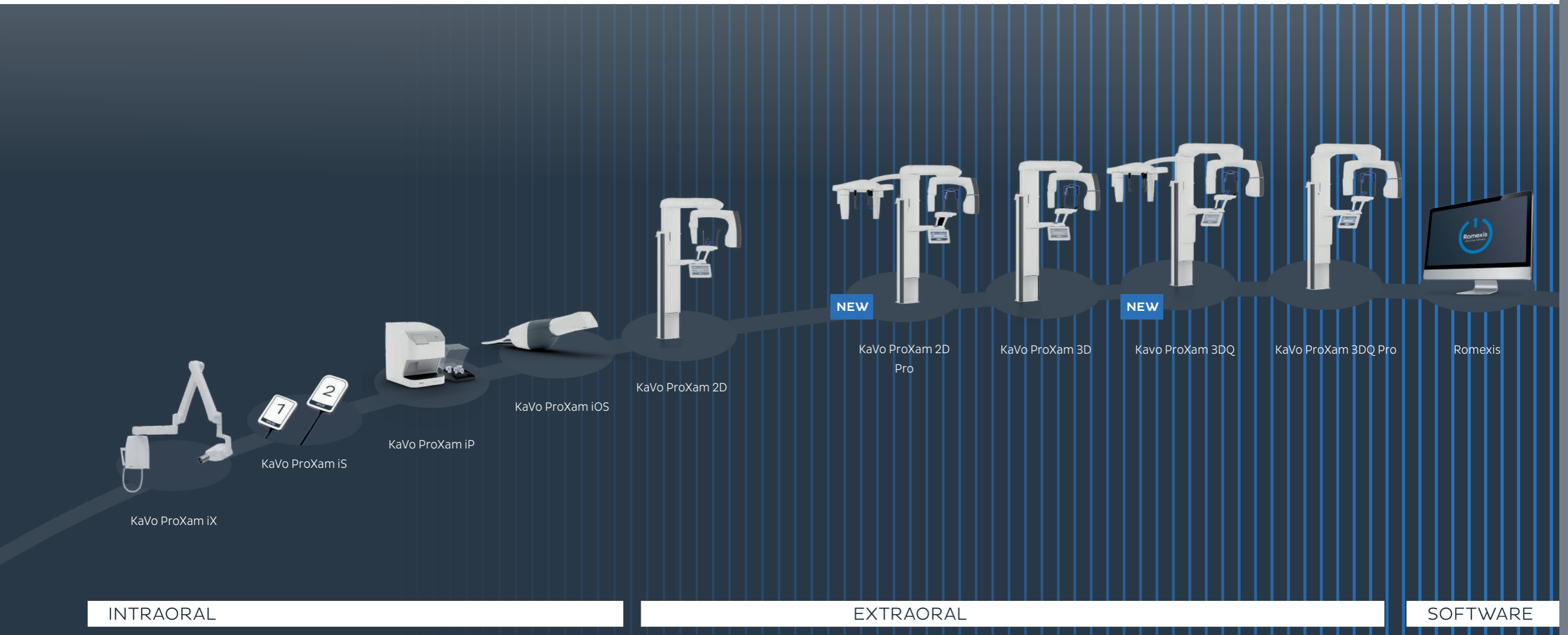

INTRAORAL

EXTRAORAL

SOFTWARE



INTRAORAL



KaVo ProXam iX
Premium class intraoral X-ray.

The KaVo ProXam iX intraoral X-ray unit is a compelling way to achieve easy, precise positioning, a simplified imaging workflow and excellent, high-resolution 2D image results.

KaVo ProXam iX

Impressive quality across a wide range of diagnostic applications.

The small focal point (only 0.4 mm) of the ProXam iX offers the best conditions for incredibly sharp images and its variable exposure parameters ensure optimal contrast and suitable greyscale settings at all times. The extra-long cone creates an accurate image geometry and guarantees a distortion-free display of the image results.

Simple and user-friendly with versatile installation options.

Wherever the KaVo ProXam iX is used – the unit can be attached either directly to the treatment unit or to the wall.

With six different arm lengths and seven different tubes and collimators, the ProXam iX offers a variety of individual setting options and a wide range of uses.

Pre-programmed adult and child modes are available for the numerous areas of application:

- Periapical application
- Occlusal application
- Bitewing or endodontic images

Alternatively, all important exposure value parameters can be set separately:

- 60 – 70 kV
- 2 – 8 mA
- 0.01 – 2 seconds exposure time

Full digital integration with Romexis.

Full integration into the Romexis software platform is possible. In combination with the ProXam iS sensors or the KaVo ProXam iP imaging plate scanner and the optionally available connector box, the exposure parameters can be automatically transferred to Romexis and stored in the respective patient file. This eliminates the need to enter the data manually at a later time.



Find out more:
www.kavo.com/en/ix



As much as necessary, as little as possible – the optimal dose of radiation.

The KaVo ProXam iX works according to the ALADA principle, abbreviated to "as low as diagnostically acceptable". ALADA means that the emitted dose of radiation per X-ray is only as high as absolutely necessary to generate a diagnostically good image.

The required exposure values are automatically retrieved based on the unit's selected setting and the lowest possible radiation dose for the image is selected.

A rectangular cone can also be used to further reduce the radiation dose, which focuses the radiation on a smaller image area.



KaVo ProXam iS
A simplified workflow for
compelling image quality.

The digital, intraoral KaVo ProXam iS X-ray sensors have a lot to offer: in addition to reliable, high-quality image results, they score points with their small size and patient-friendly design. And in combination with the KaVo ProXam iX, the simple application makes them even easier to use.

KaVo ProXam iS

Impressive image quality.

Thanks to their large dynamic range, the KaVo ProXam iS sensors consistently deliver high-quality images, regardless of whether the radiation dose is high or low. The recordings are in HD quality and, thanks to the small pixel size of 15 µm and the high resolution of over 20 lp/mm, they offer the optimal combination of noise level and contrast for a detailed diagnosis.

Solid, reliable and durable.

The KaVo ProXam iS sensors are particularly robust, have high-quality workmanship and are also covered with a protective glass fibre layer. The sensor cable is reinforced and therefore ideally suited to continuous daily use.

Perfect results through careful construction of each individual layer:

White housing – easier positioning due to better visibility

Carbon fibre plate – protection from bites and other external impacts

Shock-absorbing layer – drop and impact protection

Scintillator – guarantees sharp images

Fibre optic board – high signal-to-noise ratio and high modulation transfer function

Optical coupling – vivid images over the entire image area through perfect optimisation and control

CMOS image sensor – HD camera

LTCC electronics – robust sensor

Protection against backscatter – reliable patient protection and sharper images

Cable – premium durability with Kevlar coating and only two cores

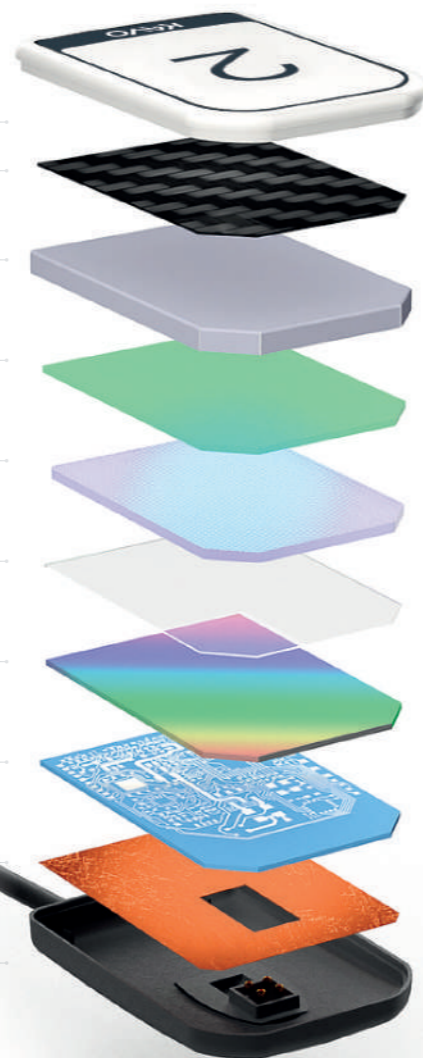

Find out more:
www.kavo.com/en/is

Well thought-out, from A to Z.

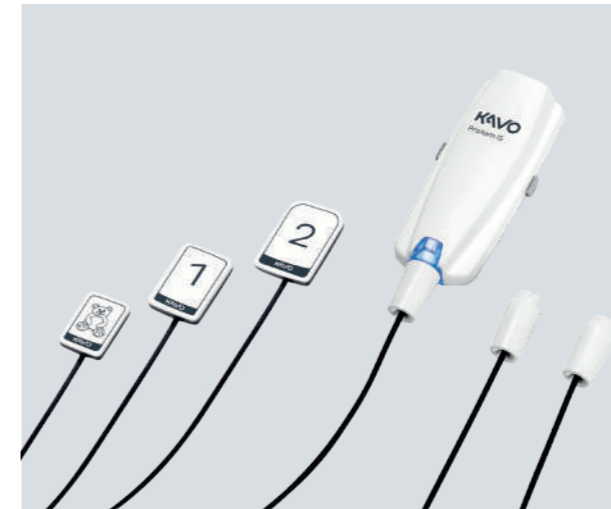

The total KaVo package.

Each KaVo ProXam iS X-ray unit is factory-prepared for easy integration and use of the KaVo ProXam iS X-ray sensors. As a result, optional retrofitting is extremely easy and is possible without the need for time-consuming cable laying on the unit. Thanks to the magnetic interface, the sensor can be attached with one hand. In this way, the sensor size can be changed quickly and easily, or the sensors can be easily transported from room to room.

Hygiene safety.

Suitable hygienic protective covers are available for the KaVo ProXam iS sensors, for easy, safe hygiene.

These sensors are a symbol of greatness.

The KaVo ProXam iS sensors are available in three different sizes:

- Size 0 – for use with children, for example, for single tooth or bitewing exposures.
- Size 1 – ideal for exposures in the anterior region.
- Size 2 – suitable for bitewing shots, for example.

The optionally available right-angle holders support the safe and easy positioning of the sensors in the oral cavity. They are also available in three different sizes: 0, 1 and 2 to match the sensors.

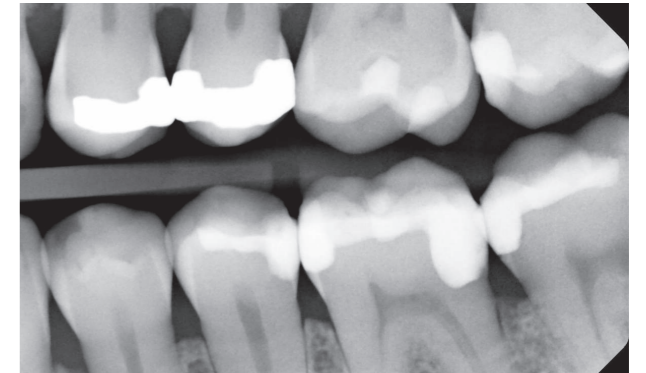

Full flexibility for many options.

There are two different installation options for the ProXam iS sensors. The sensors are either integrated directly into the KaVo ProXam iS X-ray unit, or connected to the X-ray units (including third-party supplier units) with the separate interface box via USB or Ethernet cable.

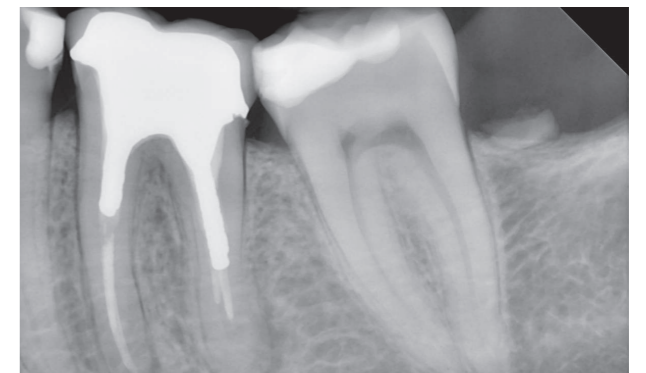



KaVo ProXam iP
The clever scanning solution.

The KaVo ProXam iP is the clever
scanner solution for fast and reliable
intraoral X-rays.

KaVo ProXam iP

Versatile and powerful.

Compact and quiet for that extra bit of comfort.

Thanks to its compact dimensions, the KaVo ProXam iP imaging plate scanner can be conveniently used in the treatment room or in a separate X-ray room (also wall-mounted). In both cases, users will be impressed by its extremely quiet scanning process.

100% exposure for comprehensive image sections.

From the particularly large active area of the imaging plates, 100% of the surface is exposed, resulting in the largest possible image area. This offers the best diagnostic conditions and helps to eliminate the need for additional images.

Safer workflow with automatic avoidance of errors.

As part of the KaVo imaging portfolio, the KaVo ProXam iP is naturally compatible with the Romexis all-in-one software. One particular advantage here is that the software automatically recognises and reports when the wrong imaging plate side was exposed. This avoids time-consuming errors and provides security for a quick and smooth workflow.

An imaging plate that has it all.

The KaVo ProXam iP imaging plates are extra thin and flexible. Equipped with a digital serial number, the exposures per foil are counted, simplifying identification and replacement of defective foils. The imaging plates also score points in terms of sustainability: due to the high-quality workmanship and the automatic deletion function, they can be reused for a particularly long time. The KaVo ProXam iP imaging plates are available in different sizes:

- Size 0 – for use with children, for example, for single tooth or bitewing exposures.
- Size 1 – ideal for exposures in the anterior region.
- Size 2 – suitable for bitewing shots, for example.

Matching disposable light protection covers are available in all three sizes to ensure the necessary process safety. They not only protect the imaging plates from light, but also from dirt and contamination. Similar to the imaging plates, the matching cassettes are also available in three sizes and can be disinfected for hygiene safety.

With high-end scan technology for premium image quality.

2D scan technology... a technical highlight of the KaVo ProXam iP: an integrated, swivelling mirror ensures that the imaging plate does not have to be moved mechanically during the scanning process. This prevents motion artefacts on the image and blurring. The particularly small pixel size of 30 µm, along with the excellent resolution of up to 16.7 lp/mm, form the foundation for clarity of even the smallest details of every image.

Fewer features for more comfort.

In addition to its compact and practical design, the KaVo ProXam iP's operating panel is extremely smart and simple: there is only one button to turn the scanner on and off. A display provides direct visual feedback on the operating information and the status of the scan. Scanning couldn't be easier.



Find out more:
www.kavo.com/en/ip

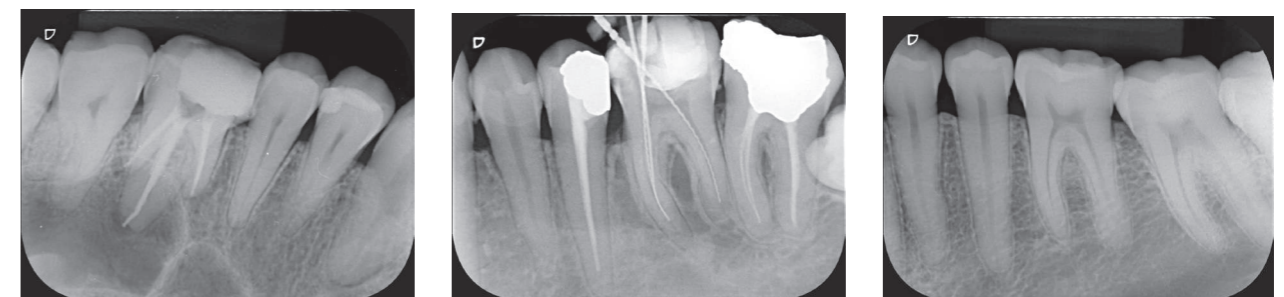



KaVo ProXam iOS
Precise, digital impressions
for more comfort.

The digital recording of impressions is a modern, comfortable and time-saving alternative to conventional impression-taking techniques. With the KaVo ProXam iOS intraoral scanner, both intraoral images and impressions and models can be scanned in a very short time. A complete dental arch can be digitally recorded in less than a minute with the KaVo ProXam iOS.

KaVo ProXam iOS

- Faster, easier, more comfortable
- Treatments can be completed in just one sitting
- High precision through the digital impression-taking technique
- Easy digital transmission and storage
- Material and shipping cost savings

Simple and flexible

The KaVo ProXam iOS can be used directly on the treatment unit or as a stand-alone solution – can be fully integrated into the Romexis software.

Compact and light

The elegant and slim design and the low weight enable optimal handling and control when capturing images.

Optimised tooth colour detection

The integrated colour assistant automatically gives suggestions for better tooth colour detection with maximum colour uniformity.

Just change the tip and scan!

You can choose between a standard tip and a SlimLine tip. This is thinner and smaller than the standard variant and is the perfect choice for scanning patients with small mouths. The tips are autoclavable for greater safety and improved protection against infection.



The standard tip



The SlimLine tip



Outstanding precision at an impressive speed

The KaVo ProXam iOS creates high-precision scans with a versatile and lively colour palette, with nearly no noise and in just a few seconds.

Low energy consumption

High efficiency with low total power consumption.



Active anti-fog scanning

The tip is automatically heated, preventing the scanner lens from fogging up and thus allowing for continuous and quick scanning.

Particularly large field of view

The KaVo ProXam iOS's large field of view gives a comprehensive, precise picture of the current situation and the patient's oral health.

Hygiene-focused operation

Two buttons on the scanner make it possible to operate the scanning software without a mouse or keyboard. This is not only more convenient, but also puts hygiene first by preventing possible cross-contamination.

NEW

Innovative technology, convenience & flexibility

The KaVo Imprex combines the advanced digital scanning technology of the ProXam iOS scanner with the user-friendly Romexis software to create a precise and detailed 3D representation of the patient's mouth.

The mobile scanning station can be easily positioned next to any dental unit and adjusted for working anywhere between the 9 and 3 o'clock positions. The scanner holder can be mounted on both sides, making it suitable for right- and left-handed users.

There's plenty of room for the dentist's foot under the tripod leg. The dentist can use the 15-inch touchscreen of the KaVo Imprex to discuss intraoral scans and treatment plans directly with the patient. Intraoral scans are stored directly in the Romexis database via the integrated LAN and Wi-Fi connections and are immediately accessible on all workstations in the same network.



KaVo ProXam iOS

A real all-rounder for daily use.



Find out more:
www.kavo.com/en/ios



The Romexis CAD/CAM module

The ideal addition to the KaVo ProXam iOS scanner.

As part of the KaVo imaging portfolio, the KaVo ProXam iOS is compatible with the Romexis software. The appropriate Romexis CAD/CAM software module was specially developed to simplify the entire workflow as part of intraoral scanning. Romexis CAD/CAM offers practical functions for capturing, visualising and analysing digital impressions, and optimises the entire workflow from the intraoral scan to the transmission of the digital data.

The all-in-one Romexis software eliminates the need for time-consuming data imports and exports and makes it possible to combine scan data and CBCT images. Combining various image data offers a multitude of new possibilities and makes implant planning or the creation of drilling template designs easier.



Orthodontics

Complete dental arch scans for digital orthodontic treatment planning pose no challenges for the KaVo ProXam iOS. The intraoral scan data can be combined with CBCT images, for example, and used to identify root movements and to monitor treatment progress and results.

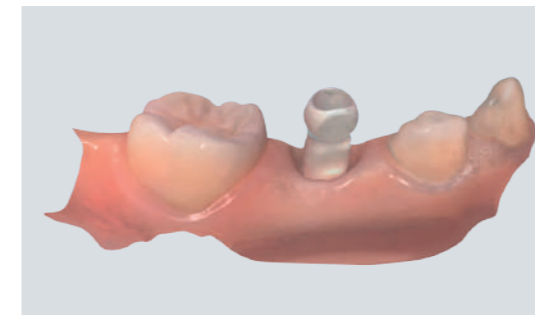

Implantology

Implant positions can be scanned using scanbodies for the abutment design. Abutment recordings for the creation of crowns and bridges are also quick and easy. The intraoral scan data can be combined with CBCT images for digital implant planning or used to create drilling templates.

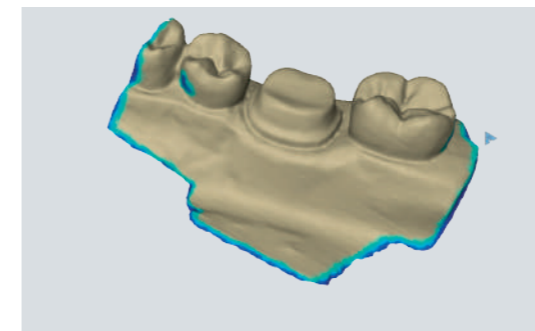

Prosthetics

Scans of preparations or abutments can be evaluated on the screen and then sent directly to the laboratory for the creation of crowns, inlays, onlays, veneers or bridges, for example. Scans taken with the KaVo ProXam iOS are suitable for temporary restorations or wax-ups as well as for the production of dental splints, removable dentures or other prosthetic solutions.

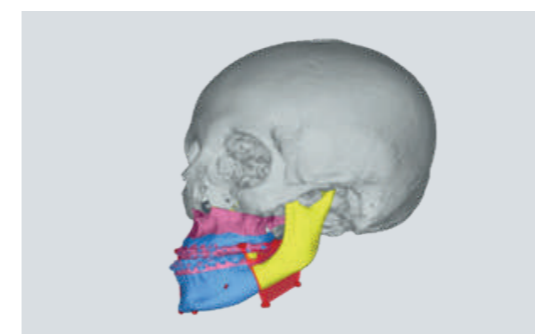

Oral and maxillofacial surgery

Intraoral scans can be overlaid with CBCT data for treatment planning or the fabrication of dental prostheses.



EXTRAORAL

KaVo ProXam 2D | KaVo ProXam 2D Pro Extraoral imaging at the highest level.

The KaVo ProXam 2D range of imaging devices, comprising the ProXam 2D S2 and ProXam 2D S3, offers comprehensive solutions for modern radiology. Specially developed for the daily tasks and challenges of dental imaging, the KaVo 2D range provides panoramic, extraoral bitewing, temporomandibular joint and sinus images, while meeting the most exacting demands in terms of image quality and ease of use.

The use of innovative technology at KaVo follows a clear goal: it must add real value in everyday practice. The KaVo ProXam 2D X-ray portfolio rises to the requirements in every respect and simplifies operation with its many automated presets and a multitude of smart support functions. The 2D image results are also impressive, with high resolution and a compelling level of detail. The advanced, robot supported selectively compliant articulated robot arm (SCARA) technology also ensures anatomically perfect image geometry with high-precision movements.



Imaging with the KaVo ProXam 2D

The perfect symbiosis of simple operation and high image quality.

User and patient comfort go hand in hand.

The 2D imaging units can be controlled via desktop software on a PC or, for added user-friendliness, via the swivelling touchscreen display on the unit itself. Operating the touch display is simple and intuitive: the most recently used modes are displayed on the start screen, allowing the user to quickly select the desired X-ray programme. After selecting the programme, the step-by-step instructions guide you through the entire X-ray workflow.

KaVo ProXam 2D X-ray units also offer added patient comfort: thanks to the spacious, vertical range of motion, it is easy and convenient to take pictures of particularly tall patients as well as of children or wheelchair users. The open architecture allows for comfortable face-to-face patient positioning, which is a useful feature to reassure anxious patients. For easy orientation, the patient's position is shown on the touch display. The sagittal plane, the Frankfurt horizontal plane and the focus layer are projected via the triple laser system.

Functional and timeless.

Early in the design process, priority was given to developing a compact, space-saving unit. The KaVo ProXam 2D impresses users not only with its timeless and attractive design, but also with material and processing quality that stands the test of time.

A wide range of programs.

In addition to the standard panorama programme, there are other programmes to choose from:

- Bitewing
- Temporomandibular joint
- Sinus
- Optional Ceph imaging for all orthodontic needs
- Dynamic Exposure Control (DEC)

Less radiation with the same image quality.

To reduce the radiation dose, the exposure area can be focused on the diagnostic target area using the optional "Horizontal and vertical segmentation" program. Compared to the full panoramic exposure, the radiation dose is reduced by up to 90%.

To protect young patients, KaVo ProXam 2D imaging devices offer a special Child mode within each program, which reduces the image area and exposure times, and thus the radiation dose. This children's mode is automatically activated as soon as the smallest patient size is selected in the respective programme. As soon as the respective settings have been made, the KaVo ProXam 2D X-ray unit automatically adjusts all exposure parameters and the kV and mA exposure values can then be readjusted manually.



The technological highlights at a glance:

- The patented SCARA (Selectively Compliant Articulated Robot Arm) technology ensures anatomically correct image geometry.
- Easy-to-use touch display with a variety of practical presettings.
- Fully integrated into the Romexis all-in-one software for additional time savings in the digital process.
- More flexibility with the ability to expand to the cephalometric unit.

KaVo ProXam 2D Superb basic imaging

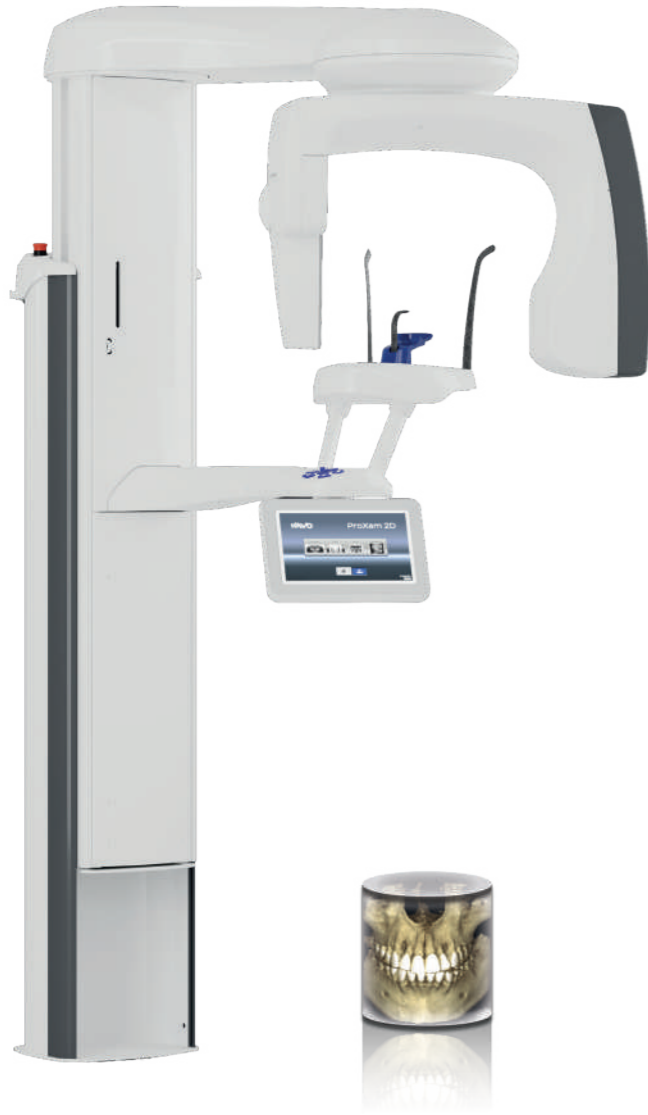

The double-jointed model (SCARA2) KaVo ProXam 2D S2 is designed for all basic imaging requirements. It includes basic programs for panoramic extraoral bitewing, TMJ and sinus imaging.

Special highlights: The extraoral bitewing imaging program offers improved interproximal angulation geometry, which ensures more precise images of the bitewing with low radiation exposure. Optimised image quality for panoramic and cephalometric shots with consistent brightness and improved contrast can also be achieved using the Dynamic Exposure Control (DEC) program. This includes digital dynamic exposure control, which automatically adjusts the exposure parameters to the individual anatomy and bone density of each patient.

KaVo ProXam 2D Pro Perfect panoramic shots with auto focus



The KaVo ProXam 2D S3 features triple-jointed SCARA technology, which enables extra features like the unique autofocus function. The focus layer is positioned automatically using a scout image of the central incisors with low radiation exposure. The patient's anatomical landmarks are used to calculate the optimal placement with precision. This allows for virtually error-free patient positioning and significantly reduces the need for repeat exposures. SCARA 3 technology can also improve the diagnostic value of extraoral bitewing images. The "true" extraoral bitewing program is suitable for all patients and does not require any sensor positioning. Interproximal contacts are opened throughout, creating a larger diagnostic range than with intraoral bitewings. This results in increased clinical efficiency with less time and effort.

	KaVo ProXam 2D	KaVo ProXam 2D Pro
Panoramic shots	x	x
Advanced panoramic program	-	x
Extraoral bitewings	x	-
"True" extraoral bitewings	-	x
TMJ recordings	x	x
Sinus imaging	x	x
Child mode	x	x

	KaVo ProXam 2D	KaVo ProXam 2D Pro
Robotic technology, two-articulated model (SCARA2)	x	-
Robotic technology, three-articulated model (SCARA3)	-	x
ProXam ceph X-rays, scanning	x	x
ProCeph ceph X-rays, one-shot	-	x
Auto focus	-	x
DEC (Dynamic Exposure Control)	x	x



Learn more:
www.kavo.com/en/3DQ

KaVo ProXam 3D | 3DQ | 3DQ Pro

Minimum radiation dose, maximum quality.

Diagnostically impressive 3D imaging at the highest level – that is the claim of the KaVo ProXam 3D X-ray portfolio.

The two KaVo 3D X-ray units – KaVo ProXam 3D and KaVo ProXam 3DQ – offer modern, three-dimensional maxillofacial imaging at the highest level, and include numerous supplementary 2D programmes. Based on extremely small voxel sizes, the KaVo 3D X-ray units generate high-resolution and detailed CBCT images of compelling quality, even with a reduced radiation dose. The KaVo ProXam 3D series units, in combination with the all-in-one Romexis software, offer everything you need for an efficient, smart X-ray workflow. That means a safe investment, and a process-optimised digital future.

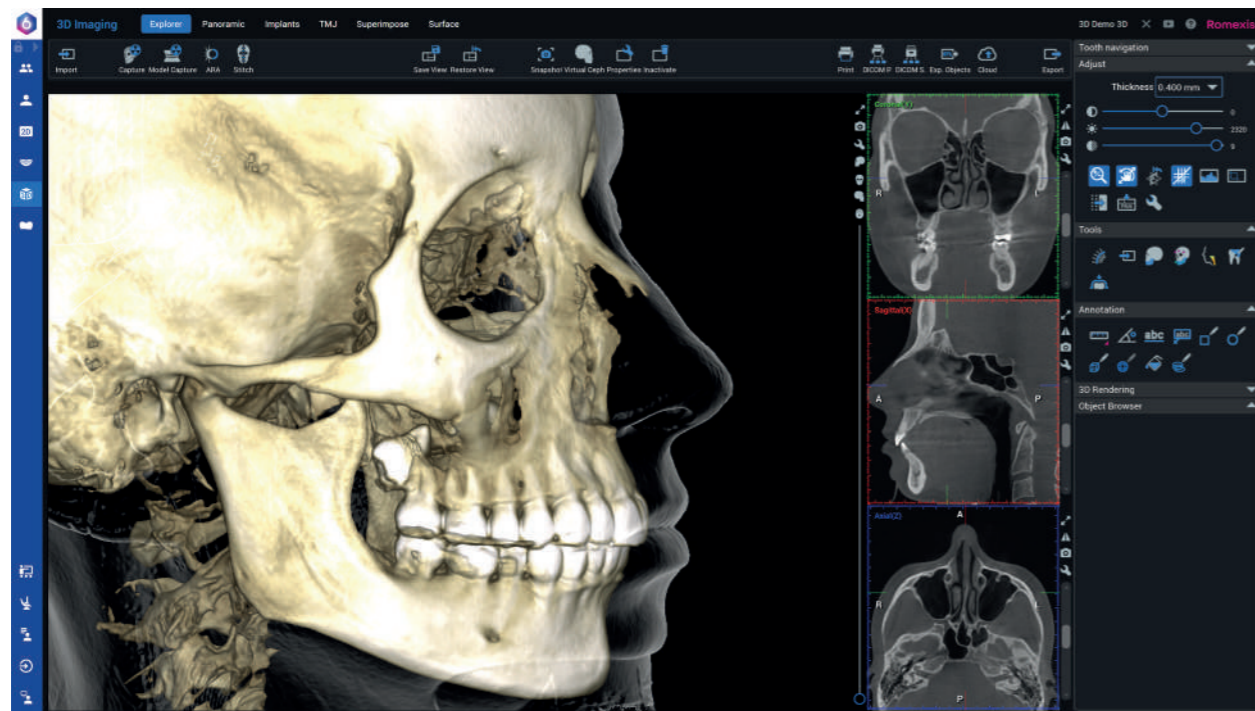

Comfort at its finest Simple, intuitive and safe.

In addition to a design optimised for user and patient comfort, all units in the ProXam 3D series offer incredibly simple, intuitive unit operation throughout the entire X-ray process.



Ease of use is a top priority.

A KaVo ProXam 3D X-ray unit can be controlled and operated in two ways: either via the swivelling touch display panel on the unit or remotely through the desktop software on a PC.

In addition to the cleverly designed graphic interface, the touch display also impresses users thanks to simple and quick programme selection and preset exposure values for a wide variety of imaging types. The step-by-step instructions, which guide users through the entire X-ray workflow, are an added bonus.

2D and 3D imaging with just one sensor.

With the intelligent SmartPan™ imaging system, the 3D sensors can be used for all 2D images. This eliminates the need for a time-consuming sensor change between CBCT and panorama imaging.

Suitable for all patients.

The open architecture of the KaVo ProXam 3D X-ray units and their spacious, vertical range of motion make it easy to position children, very tall patients, or wheelchair users.

The robot-controlled SCARA (Selectively Compliant Articulated Robot Arm) technology with 3-joint arm enables high-precision movements for anatomically correct image geometry. This allows the C-arm to be fully extended, ensuring easy entry from the side. The open face-to-face positioning gives anxious patients, for example, the sense of security they need. For better visualisation and to support patient positioning, this is shown on the touch display. The integrated quadruple laser system is available for correct patient placement.

Suitable for the KaVo 3D X-ray units:

the KaVo PHYSIO chair with stepless height adjustment and lockable castors, resulting in precise and stable patient positioning with every X-ray.

Scout images help verify volume positioning.

Before the actual 3D image, two 2D images can be created laterally and posterior/anteriorly. This helps prevent unnecessary 3D images and minimises the radiation dose for the patient.

Appropriate recording modes for a variety of indications.

Depending on the clinical situation, the tailor made recording modes of all KaVo ProXam 3D units provide accurate presets, enabling the best possible image quality with the lowest possible radiation dose.

- In the Ultra Low Dose mode, each X-ray image is created with the minimum radiation dose possible. Ideal for paedodontic dentistry, orthodontics and sinus applications (voxel size 400 or 600 µm).
 - The normal standard mode is the choice for all standard X-ray examinations (voxel size 200 µm).
 - The High Definition or HD mode is ideal for recording extremely fine structures such as fractures (voxel size 150 µm).
 - The HiRes (High Resolution) mode provides particularly high-resolution images (voxel size 100 µm).
- The endodontics mode offers the maximum resolution (voxel size 75 µm).

NEW

ProFace

Kavo ProFace offers an innovative way to capture a realistic 3D facial photo and a CBCT image in a single scan. Alternatively, it can be used simply to create a 3D facial photo – without exposing the patient to radiation. This integrated technology is compatible with all KaVo 3D imaging units.



With Ultra Low Dose to High Performance Same image quality, less radiation.

With the Ultra Low Dose imaging protocol, the KaVo ProXam 3D units offer high-quality CBCT images with a radiation dose that is lower than with conventional 2D panoramic images. The effective radiation dose per patient can be reduced by an average of 77% in Ultra Low Dose mode – without any loss of image quality.*
Based on special 3D algorithms, the Ultra Low Dose mode can be used with all voxel sizes and in all programmes – up to and including Endo mode.

For a variety of indications, exposures in Ultra Low Dose mode are particularly suited for the following indications:

1. implant planning
2. postoperative follow-up after maxillofacial interventions
3. examination of the airways and sinuses
4. In orthodontics:
 - for determination of the apical bone supply
 - for locating non-erupted or impacted teeth
 - for defining reference points for cephalometric analysis

* Study of Orthodontic Diagnostic FOVs Using Low Dose CBCT protocol (Ludlow, John Barrett and Koivisto, Juha).

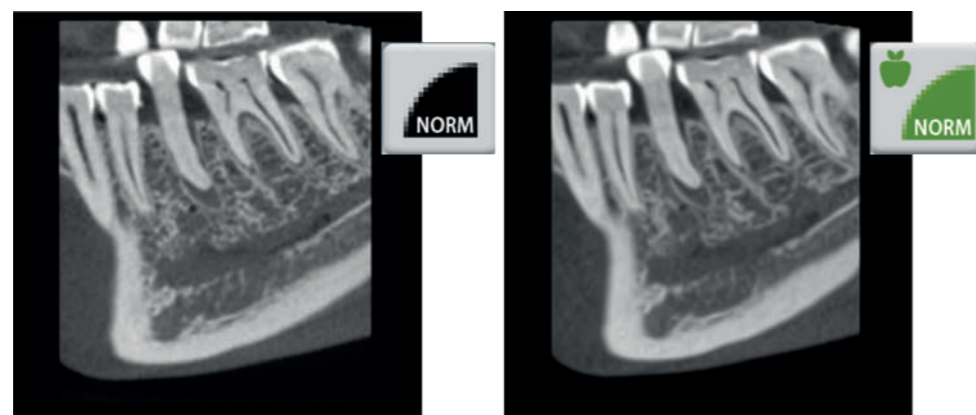

Automatically brilliant results Intelligent features for reliably good image quality.

CALM mode: For automatic correction of motion artefacts.

- Iterative algorithm for automatic correction of motion artefacts.
- Ideal for longer scan times and imaging of restless patients, especially children or older patients.
- Minimal time and radiation dose through the elimination of additional repeat exposures.



Without correction of motion artefacts



With the CALM® algorithm to correct movements

ARA mode: Outstanding image results without metal artefacts.

- Reliable algorithm for artefact-free recordings
- Automatically removes shadows and strips that can be caused by metal restorations or root fillings.
- Scientifically proven, tried and tested in practice

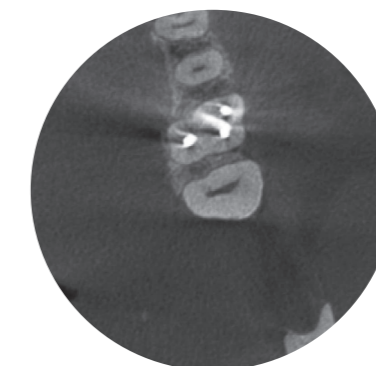

Without artefact removal

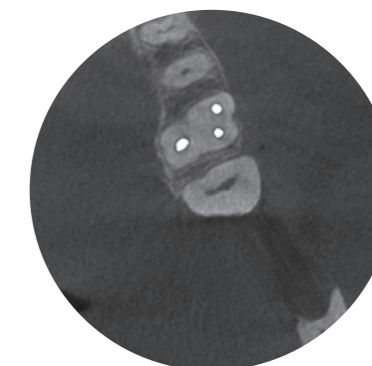

With artefact removal algorithm ARA™

AINO mode: For reliable noise reduction.

- Noise-free images without any loss of valuable details
- Enables the lowest dose of radiation
- Optimum image quality through the use of small voxel sizes, for example in endodontics mode
- When using Ultra Low Dose mode, AINO is enabled by default.

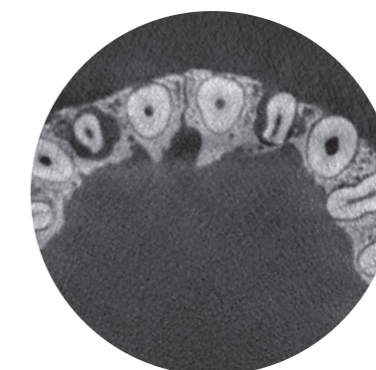

Without noise reduction

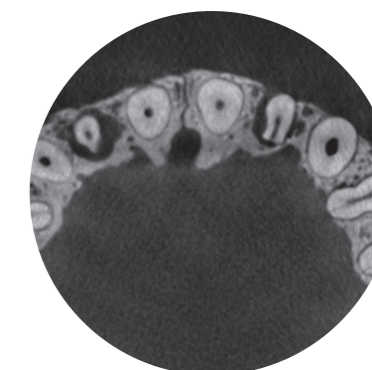

With noise filter AINO™

KaVo ProXam 3D 3D X-rays at the highest level.



The KaVo ProXam 3D product series offers a comprehensive range of 2D and 3D imaging programmes: In addition to the standard 2D panorama programmes, an extraoral bitewing programme, a mode for horizontal and vertical segmentation, a Ceph programme and a special children's mode are available.

Programmes for 3D imaging include:

- single tooth images with an endodontics function for extra high-resolution detailed images with a voxel size of 75 µm
- imaging of several teeth or entire rows of teeth including increased volume
- a double or triple tooth scan for automatic combination into a larger 3D image

KaVo ProXam 3DQ | 3DQ Pro That certain something more.



In addition to the functions of the 2D and 3D X-ray unit, the KaVo ProXam 3DQ series offers considerably more: what mostly sets the ProXam 3DQ apart is its maximum volume size, which offers additional imaging options and a greater variety of diagnostic applications. It is suitable, for example, for taking images of the sinus, nose, middle ear, petrous bone, cervical spine and airways.

The KaVo ProXam 3DQ also offers free volume positioning, its C-arm and chin rest adjust automatically depending on which volume is selected, and therefore do not require manual adjustment, with tube voltage adjustment from 90kV to 120kV on KaVo ProXam 3DQ units. This ensures excellent image quality even in the most difficult areas by minimising artefacts and significantly optimising image contrast.

	KaVo ProXam 3D	KaVo ProXam 3DQ	KaVo ProXam 3DQ Pro
Voxel size	75 / 100 / 150 / 200 / 400 µm	75 / 100 / 150 / 200 / 400 µm	75 / 100 / 150 / 200 / 400 / 600 µm
Maximum volume single scan	Ø8 x 8 cm	Ø20 x 10 cm	Ø20 x 10 cm
Extended volume single scan	Ø11 x 8	-	-
Maximum volume multiple scans	-	-	Ø20 x 17 cm
Correction of motion artefacts with CALM®	X	X	X
Imaging with Ultra Low Dose™	X	X	X
120 kV tube voltage option	-	X	X

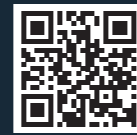

Find out more:
www.kavo.com/en/3D

	KaVo ProXam 3D	KaVo ProXam 3DQ	KaVo ProXam 3DQ Pro
Endodontics mode	X	X	X
3D dental programmes	X	X	X
3D ENT programme	-	X	X
2D panoramic imaging	X	X	X
3D model scan	X	X	X
Ceph X-ray imaging, scanning or ProCeph, one-shot	X	X	X
3D facial imaging (KaVo ProFace)	X	X	X



Find out more:
www.kavo.com/en/3DQ

Ceph imaging with KaVo ProXam

Intelligent solutions specifically for orthodontics.

Scanning ceph X-ray imaging

More flexibility for a variety of image formats. Ceph can be used as an additional feature for all extraoral KaVo ProXam imaging units and offers an extended selection of image sizes of up to 30 x 27 cm. The KaVo ProXam scans the patient's head horizontally with a narrow X-ray beam, ensuring an extremely low and effective patient dose.



High-quality equipment components particularly suitable for orthodontic requirements:

- The head positioning support and the nose clip made of carbon fibre are radiolucent, particularly stable and hygienic.
- The unit aligns itself automatically for each cephalometric image and selects the appropriate collimator.
- The rotating X-ray emitter enables cephalometric imaging without removing the 3D sensor.
- Special collimation options for paediatric imaging

NEW



KaVo ProCeph, One-shot

Short exposure time – no motion artefacts, low patient dose

With the KaVo ProCeph, one-shot you can take effective shots in the shortest possible time. Due to the rapid exposure time, there are no motion artefacts that reduce the image quality. The patient's radiation dose also remains low. The technology can achieve a maximum image size of 30 x 25 cm (with magnification), which meets all the requirements for orthodontic imaging. KaVo ProCeph can be used for all ProXam imaging units except the KaVo ProXam 2D S2.

Ceph X-ray analysis made easy with Romexis

Use the extensive functions of the software module for versatile orthodontic and orthognathic applications.

- Automatic detection of reference points
- Tools for the rapid creation of cephalometric analyses, overlays and surgical treatment plans (VTO)
- Fully customisable analysis, standards and reports
- Export and import functions via Microsoft Excel
- Compatible with Windows operating system

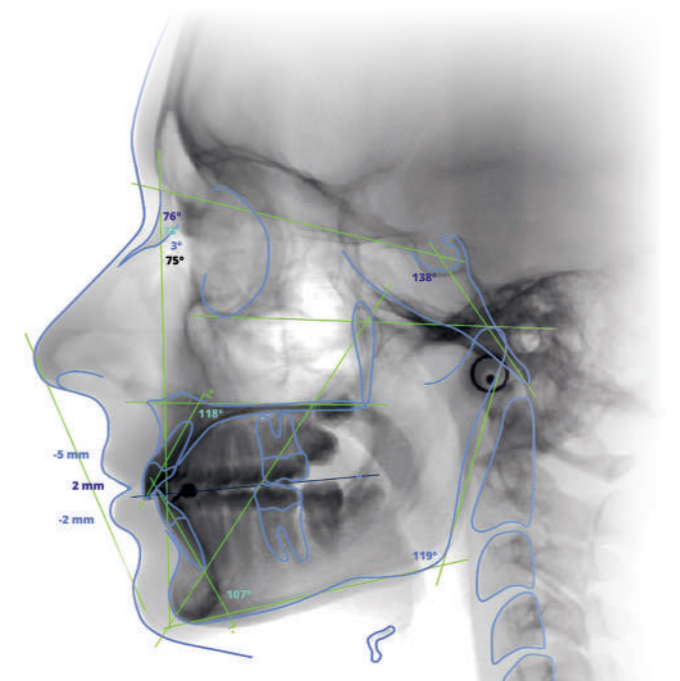



SOFTWARE

Romexis

The leading all-in-one software specifically for dentistry.

As the world's leading all-in-one software, Romexis is the suitable all-round solution for the digital challenges faced in today's dental practices and clinics. The software, which has been tried and tested for years, connects all ProXam units within the practice and enables dentists to smartly optimise and digitise their practice workflows.



COMPATIBLE WITH
MAC* AND WINDOWS

**Some features are only supported on Windows operating systems.*



Find out more:
www.kavo.com/en/Romexis

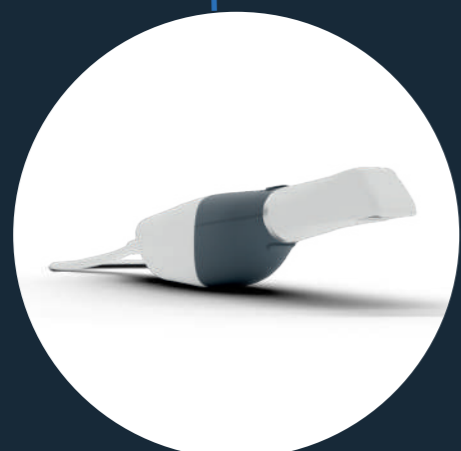

KaVo ProXam iOS



KaVo ProXam iS



KaVo ProXam 2D
KaVo ProXam 2D Pro



KaVo ProXam 3D



KaVo DIAGNOcam
Vision Full HD



KaVo ProXam iCam



KaVo ProXam iP Full HD



KaVo ProXam iX

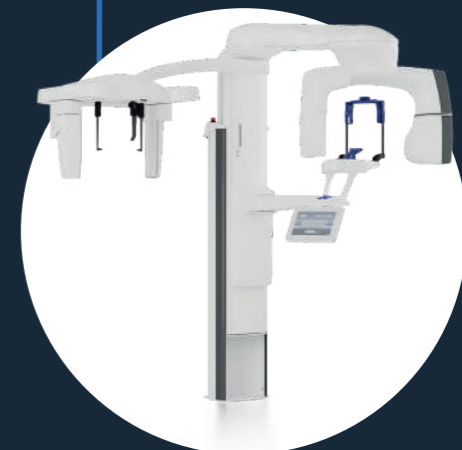

KaVo ProXam 3DQ
KaVo ProXam 3DQ Pro

Flexible and versatile

The universal software platform for the dental imaging process.

Romexis supports dentists in the creation of images and in diagnostic evaluation, processing and storage of 2D and 3D X-ray images and intraoral scans as well as in the processing of generated CAD/CAM data.

A convenient imaging programme for every need.

Romexis offers a variety of reliable tools that support either detailed treatment planning or the design of drilling templates, splints and tooth models as well as restorations for in-house 3D printing or milling.

Romexis is designed with an emphasis on intuitive and efficient operation and can be quickly and easily adapted to individual requirements or personal user needs.

Open and integrated.

With a wide range of integrated image processing programmes and compatibility with practice management systems – including third parties – Romexis is an open, comprehensive and future-proof software solution.

All 2D, 3D and CAD/CAM data can be exported or imported in standard format at no additional cost. In addition, Romexis supports the DICOM (Digital Imaging and Communications in Medicine) standard, which can also be connected to hospital systems.

A central, unit-independent image archive.

Imaging units from other manufacturers, such as panoramic X-ray units or scanners, can be connected directly to the Romexis platform using the TWAIN standard. The Romexis database can receive images from third-party units using the DICOM standard and can therefore also be used as a central, unit-independent image archive.

Integrated document management.

With Romexis, it is easy to create professional, high-quality diagnostic documents or radiology reports and send them to referring doctors. Multi-page documents of any format can also be attached directly to patient files. This is not only quick and easy, but also makes it easier to store Ceph tracings, bank transfers and other important documents.

Data security and data protection

Protecting personal and patient data is the top priority for dental practices and must be taken into account in all aspects of their work. We've integrated security features into our Romexis software from day one, enabling all users to follow responsible practices and comply with the increasingly stringent regulatory requirements.

One solution for everyone:
Romexis is the all-in-one dental software for all practice sizes in all dental specialties.

All practices and clinics

- Private practices with one treatment room all the way up to large, multi-surgery practices
- Practices with multiple locations
- Medium-sized clinics
- Hospitals and universities

200,000

users worldwide trust in Romexis

* 40 MIO

Images from more than
1.4 million patients per year.

**The figures refer to the largest networking with Romexis within a practice today.*

All data

- CBCT imaging
- 2D X-ray images
- Photos and videos
- Intraoral 3D scanners
- TWAIN units

All specialties

- Radiology
- Implantology
- Dental prosthetics
- Orthodontics
- Endodontics
- Periodontology
- Aesthetic dentistry

All platforms

- Native support for Windows and Mac**



***Some features are only supported on Windows operating systems.*

The future in sight Probably the most advanced software.

When it comes to creating and processing 2D and 3D images, Romexis is the software of choice. Powerful optimisation and analysis tools form the foundation for precise diagnoses in all specialist areas. In order to ensure maximum flexibility, Romexis naturally adapts to personal needs and individual practice or clinic requirements when it comes to imaging.

Reliable tools for reliably high-quality images.

With a comprehensive selection of tools for viewing, editing, measuring, drawing and evaluating images, Romexis optimises the diagnostic content of each X-ray image. Simple import and export functions, as well as customisable modules, can be used.

Convenient 3D diagnosis.

The 3D rendering function from Romexis offers a perfect overview of the anatomical situation and, thanks to its precise representation, is also suitable for use in patient consultations. All 3D images can be viewed from different perspectives, converted into panorama images or cross-sectional layers and edited.

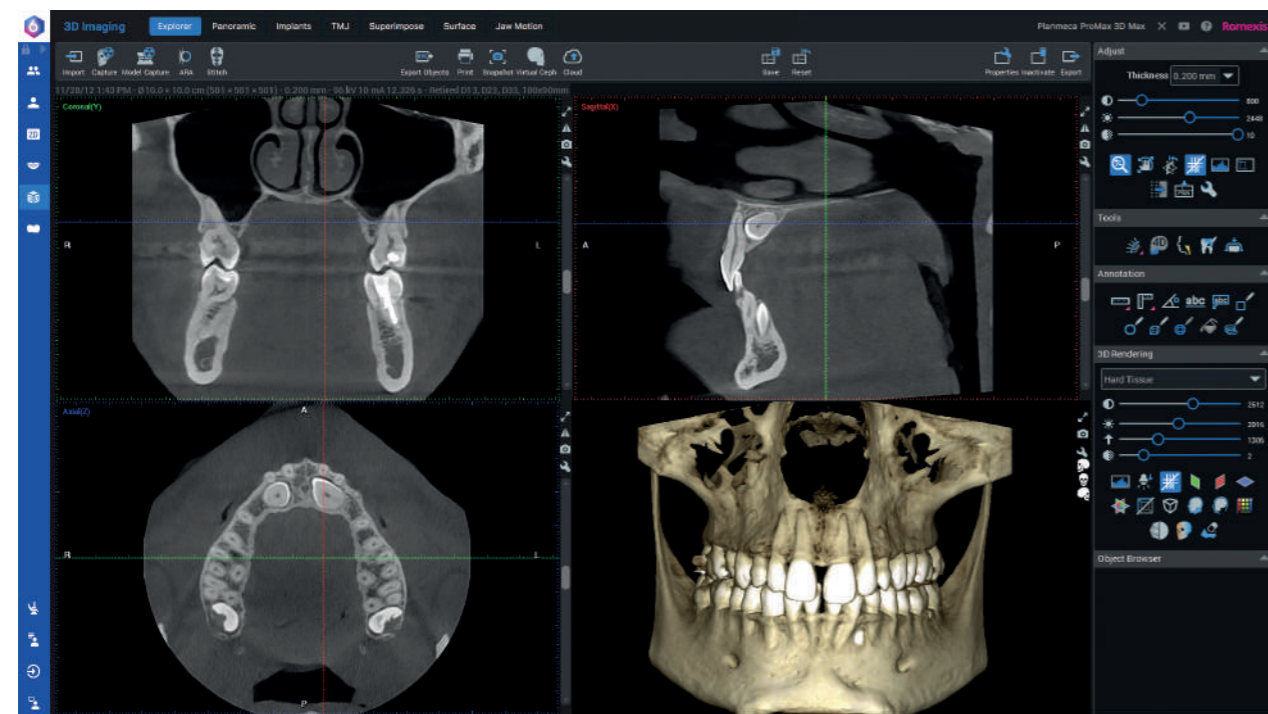

CBCT images

Romexis VR® VR-assisted implant planning.

The **Romexis® VR-solution** is a useful tool for viewing, examining and analysing 3D patient data in virtual reality. It enables more precise implant planning, better visualisation of dental anatomy and interactive patient information. With Romexis VR, dentists can experience 3D data like never before.

Main features:

- View CBCT images in virtual reality with all kinds of overlay objects that can be attached to the 3D image, including intraoral scans, crowns and segmented objects
- Crop, move, rotate and adjust CBCT images
- Implant planning with the implant library

Requirements for use:

- Meta Quest 3 headset.
Please note that KaVo does not provide or sell VR headsets..
- A desktop computer that meets the requirements for the Meta Quest 3 headset
- Romexis licence with 3D imaging and VR options
- Romexis Version 6.4.8 or higher
- Romexis VR application

Simple workflow

1. Open a CBCT image in the Romexis 3D imaging module.
2. Click on the Start VR button.
3. Put on the headset and enjoy!

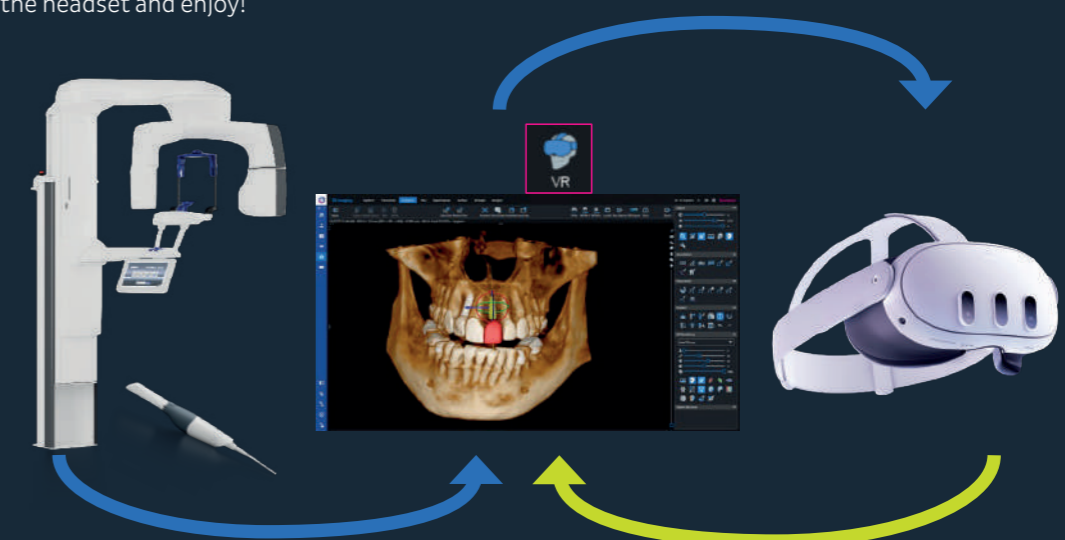

Simple and clear
The complete implant
workflow is always in view.

The Romexis 3D Implant Planning module provides all the necessary tools and technologies for digital implantology: from surgical planning to template-supported surgery.

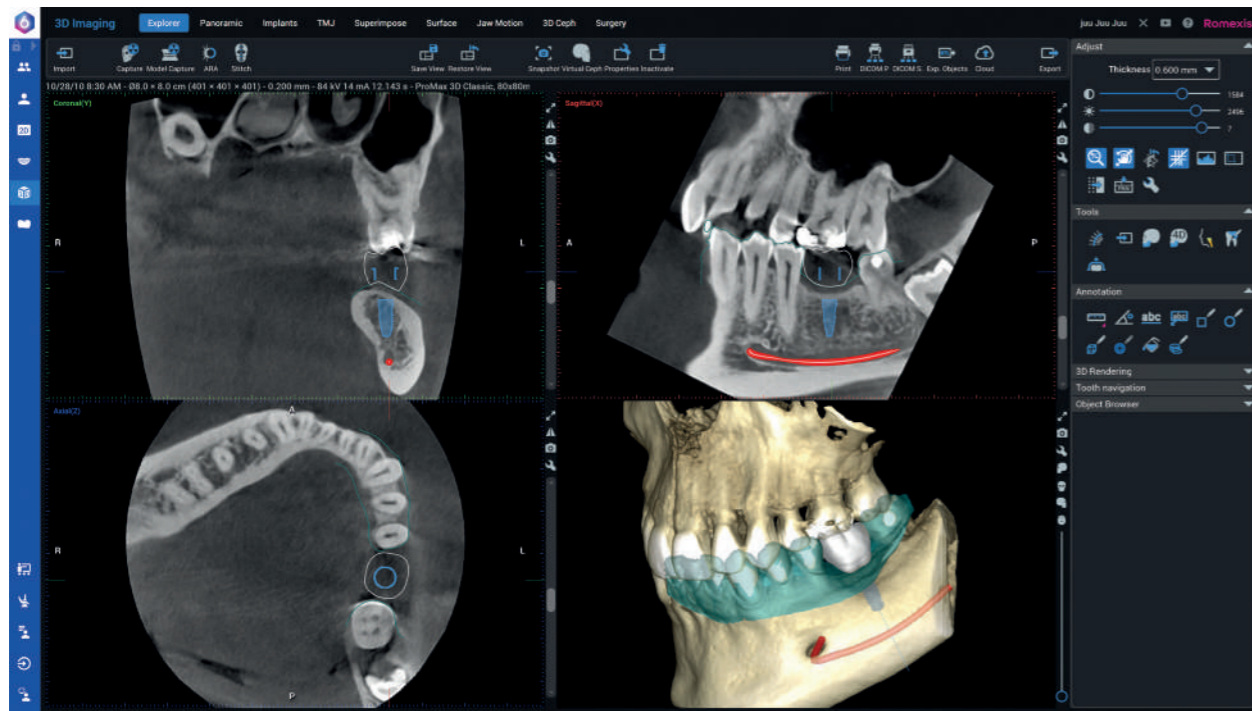

The Romexis implant library includes numerous realistic implant models and sleeves for drilling templates. In addition, Romexis grants access to implant models from over 100 manufacturers. After completing the implant planning, Romexis can produce the desired drilling template with just a few clicks.

Romexis thus offers optimal conditions for perfect top-down implant planning. By visually laying the crown and tooth model over the CBCT data, users can create a complete, virtual setup from a prosthetic and surgical point of view for optimal positioning of the implant.

The simple top-down
implant workflow.

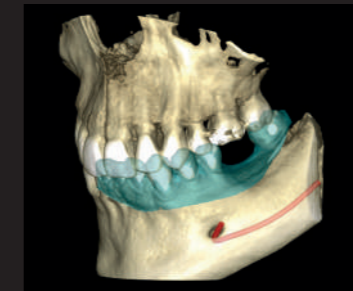
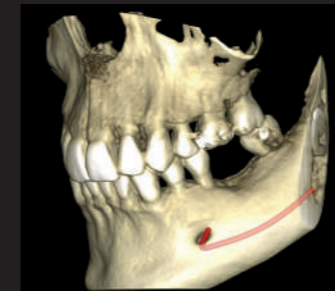

1: Mark the nerve on the CBCT image and overlay the 3D model scan with the CBCT image.

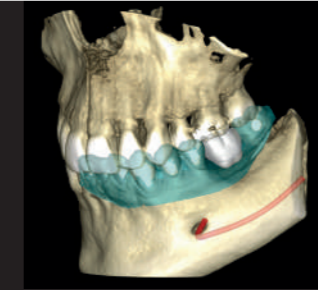
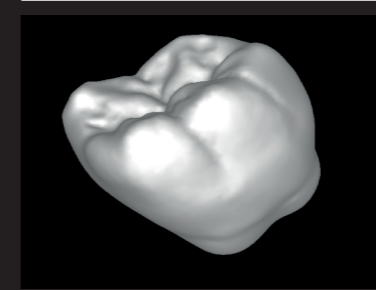

2: Import the appropriate patient-specific crown into the software from the Romexis crown library or a CAD system.

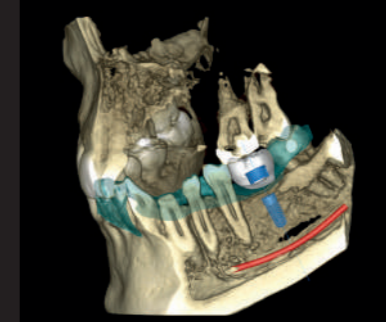

3: Select the desired implant and matching sleeve from the Romexis library and determine the optimal position from a prosthetic and surgical perspective.

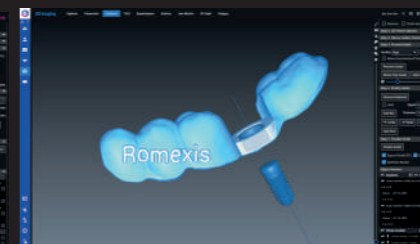
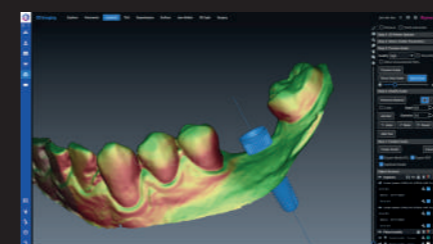

4: Design the implant template directly in the Romexis software – the software automatically creates an open STL file for the design and enables the design of complementary tooth – and mucosa-supported templates.



5: Print out the drilling template you have created using a 3D printer.

Make your orthodontic vision a reality Romexis® 2D cephalometric analysis.

The Romexis® 2D Cephalometric Analysis module provides a complete range of tools for orthodontic and orthognathic analysis. It enables fast and efficient creation of cephalometric analyses, supported by automatic landmark recognition and more than 40 predefined analysis types. Custom analyses can also be generated.

Romexis Cephalometric Analysis makes it easy to follow up on treatments, as the software automatically overlays X-ray images, tracings and profile photos from different treatment phases. It features simulation tools for treatments, including surgical planning with predictive images. Integration with the Romexis® platform allows both 2D and 3D images to be used seamlessly and stores all data in a central database. This improves user-friendliness and supports flexible workflows for clinics of all sizes. Orthodontists, general dentists and maxillofacial surgeons all benefit from this software module.

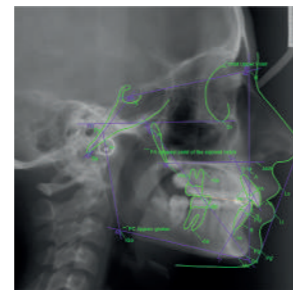

Automatic cephalometric tracings in seconds

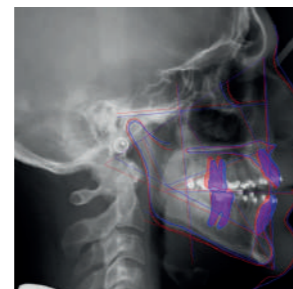

Various overlay options for precise treatment documentation and analysis



Precise surgical planning and visualisation of splints, removable dentures and other prosthetic solutions

Romexis® 3D cephalometric analysis Easy and precise visualisations for modern diagnostics.

The Romexis® 3D cephalometric analysis module is an innovative solution for orthodontic diagnostics and treatment planning that enables precise analysis based on 3D data. This module is integrated into the Romexis® software and expands the possibilities of traditional 2D analysis to include a 3D perspective.

The main features are:

- **Analysis method:** The software uses the TFA Perrotti method (total face approach), a true 3D cephalometric analysis developed by Dr Giovanna Perrotti, to provide precise diagnostic and treatment-related information.
- **Fully automatic placement of reference points:** As with 2D analysis, anatomical reference points are placed automatically. This speeds up the analysis process and reduces the need for manual intervention.
- **Clear presentation and simulation:** Supports precise planning of orthodontic and surgical treatments, including simulation of treatment trajectories and analysis of overlays for treatment tracking.
- **Seamless integration:** Works perfectly with KaVo 3D imaging devices and is fully compatible with other Romexis® platform modules. The integration of the Romexis CMF Surgery module allows users to proceed with surgical planning directly after 3D analysis.

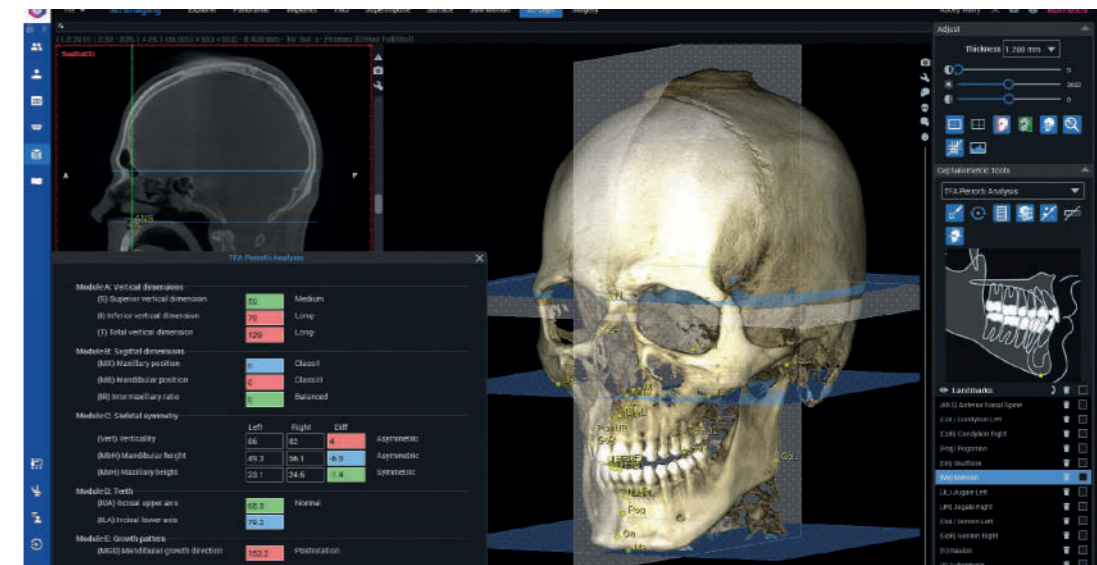

Romexis® CMF Surgery

Precise surgical planning and innovative tools

Romexis® CMF Surgery is orthognathic software for creating virtual surgical treatment plans. It offers dental surgeons the ability to evaluate cases and create intermediate and final splints based on the target occlusion and position of the jaw. All diagnostic data is captured and delivered using the same software, including CBCT scans, 2D X-ray images and DICOM data. This enables comprehensive analysis and planning through one centralised system.

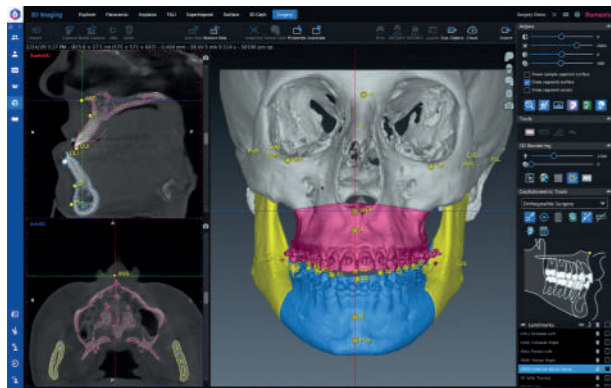

Clear presentation and simulation

Surgeons can work directly in 3D views, plan osteotomic incisions and simulate and visualise the positioning of bone fragments. This helps to visualise the surgical procedure and the post-operative result in a realistic way.

Jaw movement analysis

Simulations allow the effects of jaw movements on facial contours and aesthetics to be viewed and adjusted in advance. This is particularly important for preoperative planning and postoperative verification of surgical results.

Automatic reference marking

The software uses algorithms to place anatomical reference points automatically, increasing planning precision and efficiency. Automation helps prevent manual errors and speeds up the planning process.

AI support

The AI-based Romexis Smart feature enables automated jaw segmentation, nerve detection and adaptation of CBCT images and intraoral scans, saving users valuable time and allowing them to concentrate on surgical planning.

Romexis® Ortho Simulator

Reveal the true potential of your patient's smile.

With the Romexis Ortho Simulator, intraoral scans taken with the KaVo ProXam iOS scanner can be used to show the true potential of a patient's smile within minutes. The Romexis Ortho Simulator's smart algorithm creates treatment simulations for the most common orthodontic indications, which help to convince patients of the benefits of clear aligners or other orthodontic treatments.

Your options

- **Tooth movements and extractions:** Users can move specific teeth, extract teeth or simulate new tooth positions. This helps to visualise treatment goals and options in order to devise an optimal treatment strategy.
- **Automatic adjustment:** Romexis® Ortho Simulator uses automatic adjustment algorithms to simulate different treatment scenarios and analyse their effects on tooth position and jaw balance.

Integration with other Romexis modules:

- **Combination with Romexis CMF Surgery:** the software can be integrated seamlessly with other modules like Romexis CMF Surgery to combine surgical planning and orthodontic measures in a common workflow. The technology supports collaboration between orthodontists and surgeons to ensure consistent, patient-specific treatment.
- When combined with the KaVo ProXam iOS intraoral scanner and the aligner system of your choice, such as HeySmileR, the Romexis Ortho Simulator offers an ideal solution for digital workflow with transparent orthodontic aligners.

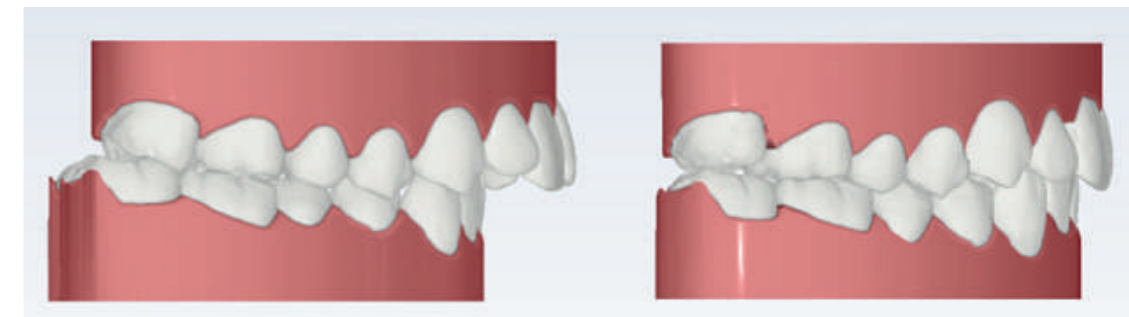



SERVICE

KaVo Maintenance: Offering you safety during routine activities at your dental practice

As a medical unit manufacturer, we are obliged to stipulate maintenance activities, technical safety inspections and integrated unit tests. This approach serves two purposes: it ensures functional safety and prevents damage, health hazards and legal risks. Regular maintenance also prevents expensive downtimes and helps you to preserve the value of your KaVo products.

In Germany, operators, unit managers and users are obligated to operate their units in compliance with the provisions of the Medical Devices Act (MPG). To ensure that the KaVo product is always ready for use, safe and retains its value, the recommended maintenance services must be carried out annually. This includes, among other things, all inspection tasks as required by the Operator Ordinance (MPBetreiberV) § 4 and § 7, as well as the prescribed safety check at intervals of 2 years.

Dental practice operators are responsible for:

- Conducting the safety check in accordance with IEC 62353
- Compliance with hygiene standards

These requirements can be met during the scope of maintenance carried out by KaVo or the certified specialist dealers.

The following individuals are authorised to carry out repairs and maintenance:

- Technicians from the KaVo branch who have received appropriate product training.
- Technicians from KaVo authorised dealers who have been specially trained by KaVo.

All certified service technicians are also obliged to only use original KaVo spare parts.



BENEFITS OF MAINTENANCE:

Regular maintenance keeps the image quality high and thus ensures the diagnostic integrity of the images!

10,000
exposures per year

Optimal
COLLIMATION
of the X-rays

Up-to-date and precise
CALIBRATION
of the **X-RAY SENSORS**

Smooth,
mechanical
MOVEMENT SEQUENCES

Maintenance components

Testing of all important functions, e.g. control lamps, safety switches, alarms.	●
Checking and, if necessary, renewing the lubrication of all important drives (linear drive, diaphragm drive, temple drive, patient support)	●
Check the installation position of the column motor nut	●
Clean the inside of the Reco-PC housing	●
If agreed, test carried out according to 6868-15	● ●
Carry out calibrations (device tool) according to the service instructions	●
Carry out constancy test according to instructions (Pano/Ceph)	● ●

● Carried out by service technician | ● Legal requirement | ● Carried out by operator on a regular basis

Service quality Made in Germany

In addition to the impressive products and practical solutions, KaVo's claim of "Dental Excellence" also includes premium service with needs-based and coordinated services. That is KaVo 360: leave all of your worries behind with KaVo premium quality – backed by optimal service.

Technical Support and Service Training

Only specialist dealers who have been trained and certified by KaVo can carry out a high-quality KaVo service. The KaVo technical support professionals provide specialist dealers with uncomplicated, fast and competent support, whenever necessary. KaVo Campus Service Training forms the qualitative foundation for service and trains specialist trade technicians on their specific tasks with the KaVo product range. Therefore, it is not only an essential part of the specialist dealer certification, it also guarantees the high KaVo service quality.

Customer service Made by KaVo.

Every day, the KaVo Customer Service team in Biberach handles over 500 customer enquiries and orders in German, English, Spanish, French, Italian, Russian, Dutch and Turkish, and ensures that every enquiry is processed within 24 hours. Daily contact with the certified KaVo specialist dealer is a very important part of KaVo customer service. To be able to offer and deliver what KaVo customers need at any time, direct and fast communication is the key.



High-quality training for outstanding products



The goal? A first-class user experience!

The new, innovative digital workflows create unprecedented possibilities for everyday work in practices and clinics. KaVo organises comprehensive training courses for all of its customers and partners so that users can fully exploit the range of services included with their products and thus realise the true value of their investment. Particular attention is paid to training sales partners and technicians to ensure the best possible customer service worldwide and at all times, for maximum customer satisfaction. All training courses are characterised by modern didactics,



innovative methods such as blended learning formats in a motivating and stimulating learning environment, and also sometimes involve dentists. The KaVo training sites enable high-quality sales, technology and user training, and offer targeted e-learning courses or advanced training webinars. In addition to this, most branches and sales partners also conduct product training courses on their own sites, thus rounding out the comprehensive education and training programme.



Technical specifications

The KaVo ProXam iX intraoral X-ray unit

Product description

The KaVo ProXam iX is a microprocessor-controlled intraoral X-ray unit with a high-frequency X-ray generator. The product has 66 pre-programmable exposure parameters for quick and easy operation. The small focal point of only 0.4 mm ensures sharp images with minimal distortion.



Adjustable exposure parameters

Tension	60-70 kV
Contrast and density of objects	2-8 mA
Exposure time	0.01-2.0 seconds, 24 levels

Key benefits

- Easy and accurate positioning, stable arm, very light weight and compact size
 - Very long range (224 cm)
 - Hygienic surfaces
 - Hand-held remote control or fixed panel, remotely installable
 - Small focal spot, automatic compensation for mains voltage fluctuation
 - Adjustable anode voltage (60, 63, 66 and 70 kV)
 - Adjustable anode current 2, 3, 4, 5, 6, 7, 8 mA
 - 24 visually detectable density levels of the exposure times
 - 11 levels of density for different films
 - Pre-programmable exposure parameters
 - Optimised image quality for all techniques, outstanding definition and sharpness
 - Automatic transfer of exposure parameters to Romexis (in combination with KaVo ProXam iS or KaVo ProXam iP and Connector Box)
 - Short and long tube (200 and 300 mm), density compensation for different tubes
 - Rectangular tube for better radiation hygiene
 - Automatic switch-on control
 - Self-diagnostic system and help codes
- Assembly:
- Wall mounting (default)
 - KaVo treatment unit integration
 - 5 selectable extension arms
- Tube head design: near the patient's chest during occlusal imaging
 - Each KaVo ProXam iX X-ray unit is prepared for use of the KaVo ProXam iS sensors. The sensors can be attached directly to the X-ray source.

Technical specifications

Generator	DC voltage, microprocessor controlled, operating frequency 66 kHz
X-ray tube	Toshiba D-041SB
Focus	0.4 mm according to IEC 60336
Tube diameter	60 mm round 36 x 45 mm rectangular
Filtration	at least 2.5 mm Al
Anode voltage	60, 63, 66, 70 kV; ±1 kV Adjustable working area
Rise time	8 ms at 70 kV
Anode current	2-8 mA DC, 1 mA steps
Exposure times	0.01-2.0 seconds, 24 levels
Focus-Skin Distance (Standard/Long)	Round (200 mm/300 mm) Rectangular (300 mm/ 345 mm)
Mains voltage	100/110-115/220-240 ±10%, 50/60 Hz
Merging	15 AT/ 8 AT
Work cycle	1:30, automatic control
Weight	33 kg total X-ray emitter: 4.2 kg with standard tube 4.5 kg with long tube
Range	152 cm, 165 cm, 178 cm, 191 cm, 203 cm

Dimensions

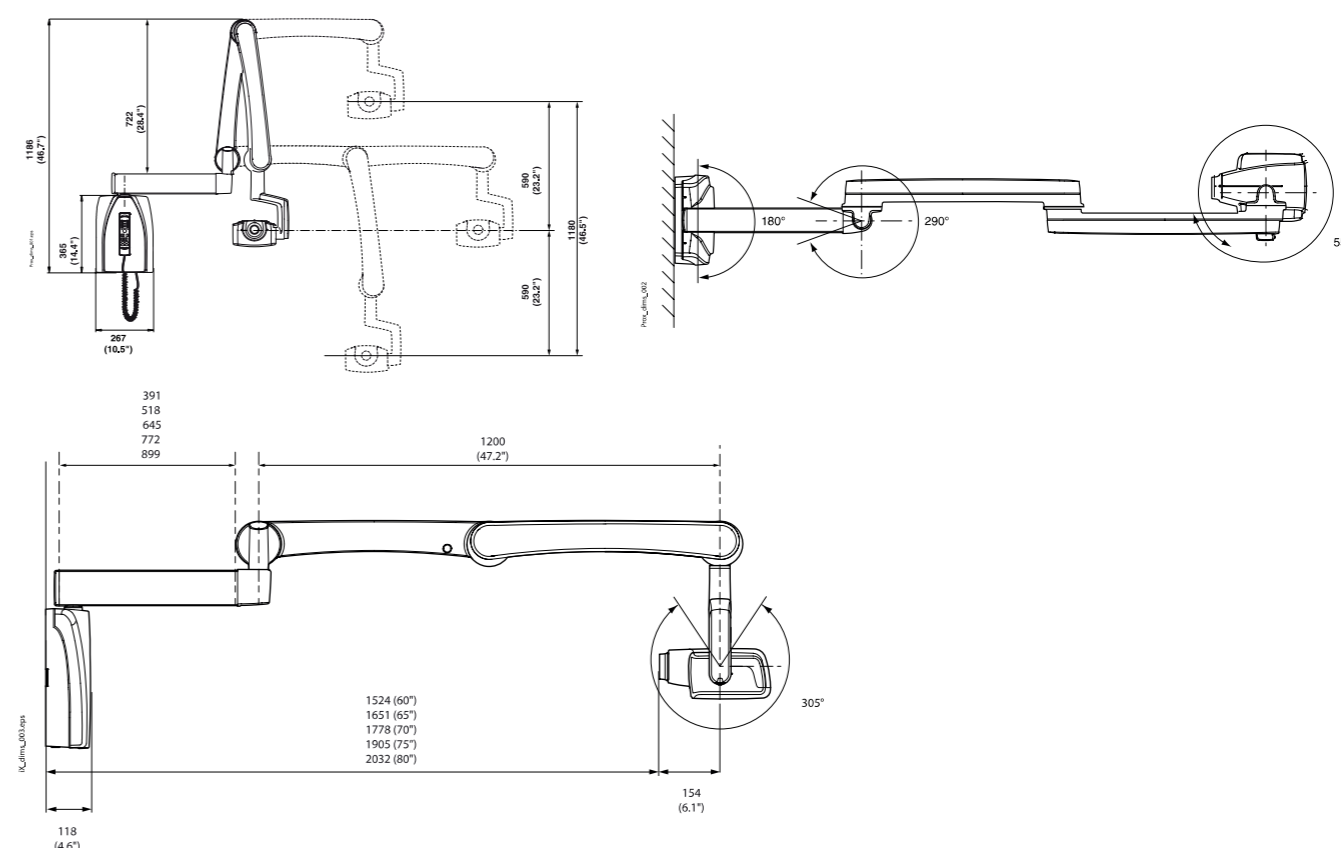

Technical specifications

KaVo ProXam iS intraoral sensors

Key benefits

- Advanced image sensor for sharp images with high contrast and low noise
- Theoretical resolution 33 lp/mm, true resolution > 20 lp/mm
- Large dynamic range
- Three sensor sizes with rounded edges
- White housing for easy positioning
- Magnetic connector for easy operation
- Colour-coded LED light on the interface box for instant feedback
- Hermetically sealed housing for the best protection against infection
- Compatible with Windows and macOS
- Plug-and-Play USB solution
- Integrated calibration for quick switching between sensors

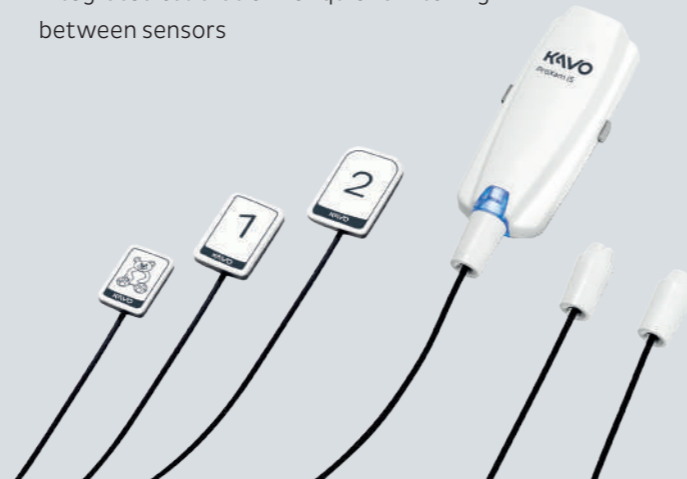

Technical specifications

Sensor	
Sensor type	CMOS with scintillator
Pixel size	15 µm x 15 µm
Image format	16 bits
Resolution (Normal)	17 lp/mm
Resolution (High)	> 20 lp/mm
Theoretical resolution	33 lp/mm
Cable length	1 m or 2 m
Expected Lifetime	10 years/100,000 cycles
Size 0	
Dimensions	33.6 x 23.4 x 7.1 mm
Active area	25.5 x 18.9 mm
Pixel matrix	1700 x 1258
Pixel count	2.14 M
Image size	850 x 629 (0.5 MP)/ 1700 x 1258 (2.13 M)

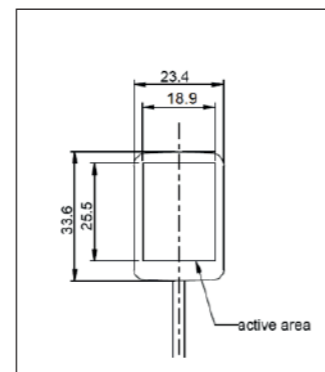

Size 0

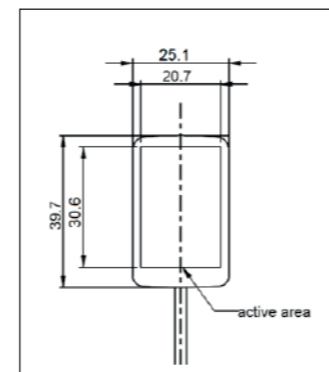

Size 1

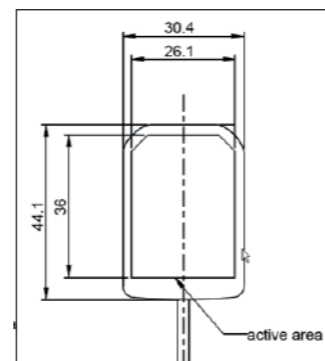

Size 2

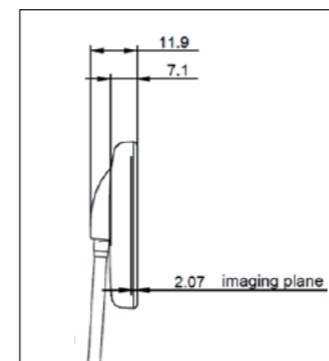

Size 0, 1, 2

Sensor

Size 1

Dimensions	39.7 x 25.1 x 7.1 mm
Active area	30.6 x 20.7 mm
Pixel matrix	2040 x 1380
Pixel count	2.82 M
Image size	1020 x 690 (0.7 M)/ 2040 x 1380 (2.82 M)

Size 2

Dimensions	44.1 x 30.4 x 7.1 mm
Active area	36 x 26.1 mm
Pixel matrix	2400 x 1740
Pixel count	4.18 M
Image size	1200 x 870 (1.0 M)/ 2400 x 1740 (4.18 M)

Interface box

Ethernet

Dimensions	112 x 46 x 24 mm
Power consumption	48 V DC 65 mA
Interface box to PoE	RJ45 10 m or 15 m
PoE to LAN	RJ45 10 m or 15 m

PoE (Power over Ethernet)

Phihong single port injector

Type	PSA16U-480 (POE)	POE15M-1AF/ POE15M-1AFE-R
Input voltage	100-240 V AC (50-60 Hz)	100-240 V AC (50-60 Hz)
Output voltage	48 V DC	56 V DC
Maximum output current	0.32 A	0.275 A
Insulation voltage primary-secondary	3000 V AC	3000 V AC

USB

Dimensions	112 x 46 x 24 mm
Cable	Permanently installed USB 2.0 power cable 2 m
Power consumption	2.5 W

Technical specifications

KaVo ProXam iP imaging plate scanner

Product description

The KaVo ProXam iP has been developed to fit seamlessly into the workflow of your practice. It is a powerful and extremely durable imaging plate scanner. The compact scanner fits into any room and helps practices/clinics avoid downtime and ensure maximum efficiency.

The imaging plate scanner uses RFID technology for a fast scanning and identification process. The intelligent imaging plates can be used several times and are immediately prepared for further imaging thanks to the built-in delete function. The flexible and pliable imaging plates are very comfortable for the patient and are available in sizes 0, 1 and 2.



Key benefits

- Compact and stylish scanner that takes up minimal space
- Durable and maintenance free
- Ideal for chairside use
- Easy and intuitive to use
- The scanning process protects the imaging plates
- Automatic deletion of data after each scan
- Easy infection control thanks to the light protection covers
- Fully compatible with Windows and macOS
- Imaging plates in sizes 0, 1 and 2
- 100% of the imaging plate is exposed.
- Ergonomic design: rounded edges, thin and wireless
- White backing for enhanced visibility
- Equipped with an RFID chip: exposures can be counted and the imaging plates tracked
- Automatic error detection in the Romexis software if the wrong side of the image plate is exposed

Technical specifications

Imaging plate scanner

Classification

Medical Device Directive (93/42/EEC)	Class 1
Laser class according to EN 60825-1:2014: 1	Class 1

General technical data

Dimensions	167 x 231 x 216 mm
Weight	approx. 4 kg
Work cycle	100%
Noise level during scanning process	approx. 45 dB (A)
Scan time	20 sec.
Delayed display	~26 sec.*
Expected Lifetime	8 years

Network connection

LAN technology	Ethernet
Standard	IEEE 802.3u
Data rate	100 Mbit/s
Connection	RJ45
Connection type	Auto MDI-X
Cable type	≥ CAT5

Electrical data for imaging plate scanners

Nominal voltage	24 V DC
Max power consumption	0.5 A
Max power input	< 12 W
Protection class	II

Electrical data power supply

Input voltage rating	100-240 V AC
Frequency	50/60 Hz
Rated output voltage	24 V DC
Max output current	0.5 A

Technical specifications

The ProXam 2D Panorama X-ray unit

Product description

The KaVo ProXam 2D X-ray unit offers a wide range of extraoral imaging methods:

- Panoramic imaging
- Imaging of the maxillary sinus/sinus
- Imaging of the temporomandibular joint
- Ceph option



Microprocessor-controlled resonance mode generator with constant potential

- Very high operating frequency 80–150 kHz (resonant mode)
- Maximum residual ripple 670 Vpp (0.4% 84 kV)
- Ultra short rise time, < 3 ms
- Very wide range of exposure parameters, 1–16 mA / 60–84 kV
- Low patient dose
- Universal power input
- Mains voltage fluctuations are automatically compensated

Reliable mechanical construction

- Small size and light weight, total weight 113 kg
- Unique 2-joint SCARA (Selectively Compliant Articulated Robot Arm) technology enables movements and imaging geometries for basic panoramic imaging, smooth and quiet microstepping motors
- Telescopic column without counterweight. Maximum height adjustable.
- Automatic primary collimator with four leaves
- Available as wall mounted

Available 2D imaging programmes

Programme	Availability
Basic panorama programmes (incl. double lateral TMJ programme, double posterior/anterior TMJ programme, posterior/anterior sinus programme)	Included in scope of delivery
Horizontal and vertical segmentation	Optional
Bitewing Panorama Programme	Optional
Ceph imaging	Optional
Optional child mode	Included in scope of delivery
DEC (Dynamic Exposure Control): Panorama DEC, Cephalostat DEC	Optional

Sensor system

- One interchangeable sensor for panoramic and cephalometric images or two fixed sensors
- Easily and quickly switch between imaging modes
- Very small and adjustable pixel size, high-resolution imaging, minimised motion blur
- Highly sensitive detection → low dose of radiation
- Dental Image Contrast Enhancement (DICE) automatically optimises the image contrast and exposes image details throughout the grey scale
- Fast Ethernet connection to the computer
- Radiation hardened long-life sensor

Ceph (optional)

- Stable construction
- Automatic alignment of the radiation source
- Clever design with user-friendly head positioning, pivoting nose pad, low-absorption carbon fibre positioning cones
- No mechanical soft tissue filter, soft tissue filter in imaging software
- Image size from 18 x 18 cm to 30 x 27 cm
- All projections possible: lateral, AP/PA, oblique, submental apex, Waters', AP Towne, Hand & Wrist

Dimensions

The following figures show the dimensions of the X-ray unit and the minimum space required (grey area) for smooth operation. The maximum height is adjustable.

The maximum height is adjustable

Weight	119 kg (3D unit) 26 kg (Ceph)
Chin rest level	96–178 cm
Ceph ear pad height	97–179 cm

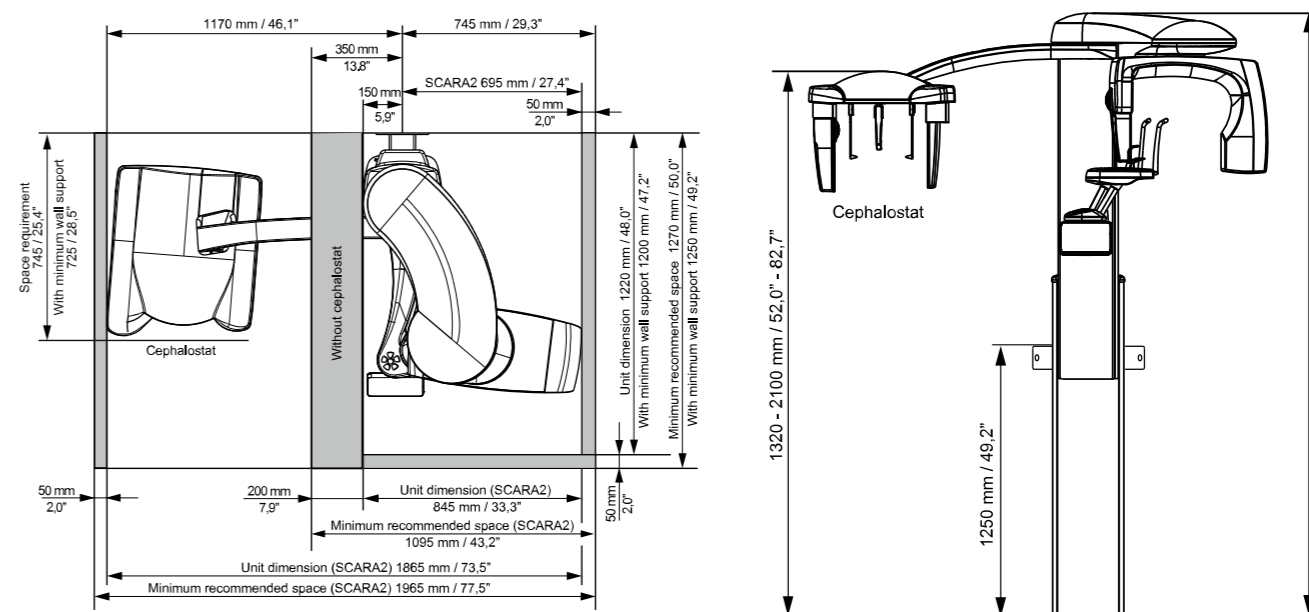

Technical specifications

KaVo ProXam 2D Pro panoramic X-ray unit

Product description

The KaVo ProXam 2D Pro X-ray unit offers a wide range of extraoral imaging methods:

- Panoramic imaging
- Imaging of the maxillary sinus/sinus
- Imaging of the temporomandibular joint
- Ceph option



Microprocessor-controlled resonance mode generator with constant potential

- Very high operating frequency 80–150 kHz (resonant mode)
- Maximum residual ripple 670 Vpp (0.4% 84 kV)
- Ultra short rise time, < 3 ms
- Very wide range of exposure parameters, 1–16 mA / 60–84 kV
- Low patient dose
- Universal power input
- Mains voltage fluctuations are automatically compensated

Reliable mechanical construction

- Small size and light weight, total weight 113 kg
- Unique 3-joint SCARA (Selectively Compliant Articulated Robot Arm) technology enables movements and imaging geometries for basic panoramic imaging, smooth and quiet microstepping motors
- Telescopic column without counterweight.
- Maximum height adjustable.
- Automatic primary collimator with four leaves
- Available as wall mounted

Available 2D imaging programmes

Basic panoramic programs (incl. double lateral TMJ program, double posterior/anterior TMJ program, posterior/anterior sinus program))	Included in scope of delivery
Horizontal and vertical segmentation	Optional
True bitewing program	Optional
Advanced panoramic programs (incl. interproximal panoramic program, orthogonal panoramic program, tri-angled posterior/anterior TMG program, lateral and linear sinus program).	Optional
Ceph X-ray imaging, ProCeph (one-shot cephalostat) or scanning ceph optional	Optional
Child mode	Included in scope of delivery
DEC (Dynamic Exposure Control): Panorama DEC, Cephalostat DEC	Optional

Sensor system

- One interchangeable sensor for panoramic and cephalometric images or two fixed sensors
- Easily and quickly switch between imaging modes
- Very small and adjustable pixel size, high-resolution imaging, minimised motion blur
- Highly sensitive detection → low dose of radiation
- Dental Image Contrast Enhancement (DICE) automatically optimises the image contrast and exposes image details throughout the grey scale
- Fast Ethernet connection to the computer
- Radiation hardened long-life sensor

Ceph (optional)

- Stable construction
- Automatic alignment of the radiation source
- Clever design with user-friendly head positioning, pivoting nose pad, low-absorption carbon fibre positioning cones
- No mechanical soft tissue filter, soft tissue filter in imaging software
- Image size from 18 x 18 cm to 30 x 27 cm
- All projections possible: lateral, AP/PA, oblique, submental apex, Waters', AP Towne, Hand & Wrist

Dimensions

The following figures illustrate the dimensions of the X-ray unit and the required minimum amount of space (grey area) for smooth operation.

The maximum height is adjustable

The maximum height is adjustable

Weight	119 kg (2D unit)
	26 kg (scanning ceph X-ray)
	20 kg (ProCeph)
Chin rest level	96–178 cm
Height of ceph X-ray ear pads	97–179 cm

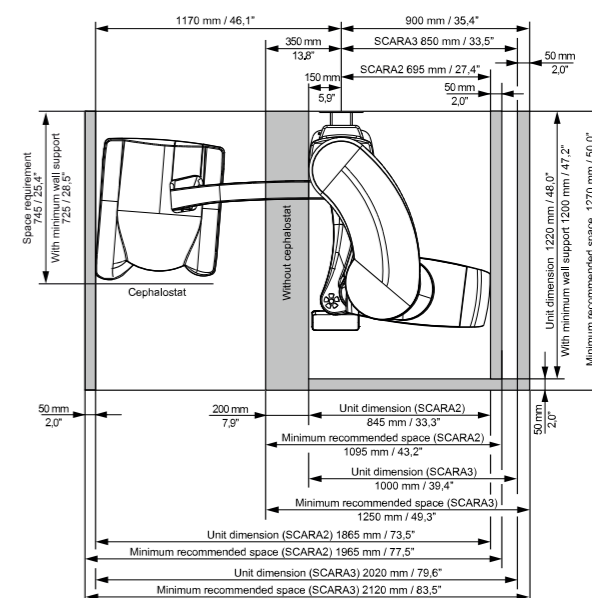
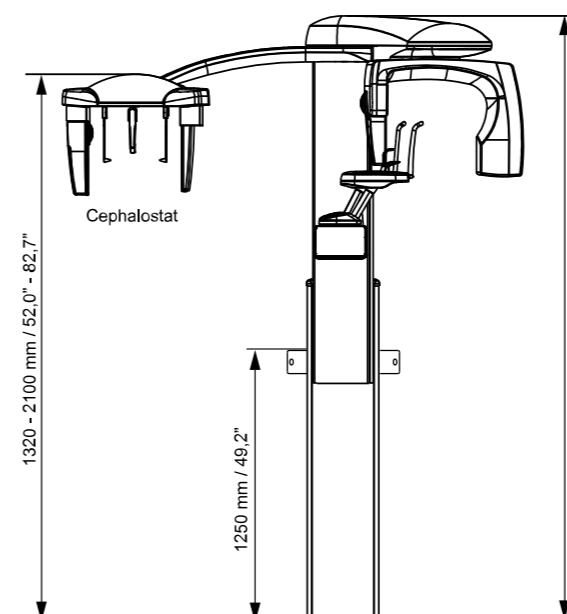

Technical specifications

KaVo ProXam 3D CBCT X-ray unit

Product description

The KaVo ProXam 3D offers state-of-the-art, three-dimensional maxillofacial imaging at the highest level, including numerous additional options for creating 2D panoramic, extraoral bitewing and cephalometric images.

On the basis of extremely small voxel sizes, the KaVo 3D X-ray unit generates high-resolution and detailed CBCT images in diagnostically compelling quality and, thanks to the easy-to-use, intelligent setting modes, the image quality is impressive even at small radiation doses.



2D Imaging

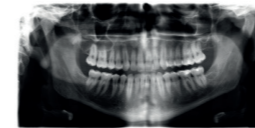

The **SmartPan system** uses the same 3D Sensor for 2D panoramic images. Also includes MultiView SmartPan, which creates nine panoramic images at different angles. MultiView SmartPan can be used in the panorama programmes.



The **Auto Focus function** automatically positions the focal layer based on a low-dose Scout image of the centre of the patient's incisors. It uses points of reference in the patient's anatomy to calculate placement, allowing for error-free patient positioning.

Available: basic panorama programmes, horizontal and vertical segmentation, bitewing panorama programme.

2D Imaging

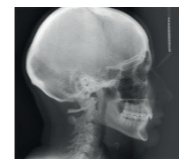

Scanning cephalometric X-ray or KaVo ProCeph for cephalometric images

Available resolution modes

Mode	Endodontics (optional)	High Resolution	High Definition (HD)	Normal	Low
Voxel size in µm	75	100	150	200	400

3D imaging programmes and volume sizes

3D standard programmes

Programm	Volumen (Kindgröße), cm	Beispiel	Modus/ Voxel
Tooth	Ø 5 x 5 (Ø 4,2 x 4,2)		Endo 75 µm HR 100 µm HD 150 µm N 200 µm d L 400 µm
	Ø 5 x 8 (Ø 4,2 x 6,8)		HD 150 µm N 200 µm d L 400 µm
Teeth	Ø 8 x 5 (Ø 6,8 x 4,2)		HD 150 µm N 200 µm d L 400 µm
	Ø 8 x 8 (Ø 6,8 x 6,8)		
Teeth (Extended volume)	Ø 11 x 5 Ø 11 x 8		HD 150 µm N 200 µm d L 400 µm
Double scan	2 x teeth		N 200 µm d L 400 µm
Triple scan	3 x teeth		N 200 µm d L 400 µm
Modelscan	Ø8x4		HD 100µm

Endo = Endodontics, HR = High Resolution, HD = High Definition, N = Normal, L = Low, d = Default

Imaging modules

3D Imaging



KaVo ProXam 3D provides high-resolution volumetric 3D images of the lower and upper jaw as well as the entire dental area.



3D endodontic imaging mode

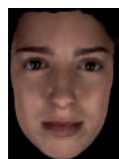

KaVo ProFace enables 3D photo shooting in the same session as the X-ray imaging or separately.

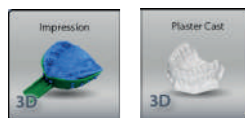

Model scan programs:
Special programs create high-precision 3D images of impressions and plaster casts

Technical specifications	
Classification	Medical Device Directive 93/42/EEC (Class IIb) RoHS: 2011/65/EU IEC 60601-1: Class I, Type B CISPR 11: Class B IP Classification: IP20
Generator	Constant potential, microprocessor controlled, resonant mode, operating frequency 80-150 kHz, Power factor corrector, meets the IEC 60601-2-7 standard
X-ray tube	D-0545B
Focal spot size	0.5 x 0.5 mm, according to IEC 60336
Total filtering	2D/Ceph: 2.5 mm Al eq 3D: 2.5 mm Al + 0.5 mm Cu
Anode voltage	2D: 60-84 kV Ceph: 60-84 kV 3D: 60-90 kV
Anode current	2D: 1-16 mA Ceph: 1-16 mA 3D: 1-14 mA (Steps with the R20 series: 1, 1.1, 1.25, 1.4, 1.6, 1.8, 2.0, 2.2, 2.5, 2.8, 3.2, 3.6, 4.0, 4.5, 5.0, 5.6, 6.3, 7.1, 8.0, 9.0, 10.0, 11.0, 12.5, 14.0, 16.0)
Exposure time	2D: 2.5-16 s Ceph: 6-10 s 3D: 3-36 s
SID	2D: 501 mm Ceph: 1700 mm 3D/SmartPan: 528 mm
Focus-skin distance	2D/3D: min. 150 mm Ceph: 1500 mm
Enlargement	2D: constant 1.2 Ceph: 1,13 3D: 1,58
Panorama image size	SmartPan: 190 x 100 mm
Line voltage	100-220 V/50 or 60 Hz 230-240 V/50 Hz Power Factor Corrector
Line current	8-17 A

Sensor specifications

3D	
Pixel size	127 µm
Active surface	13 x 13 cm

Sensor	
CCD pixel size	48 µm
Image pixel size	48/96/144 µm (adjustable)
CCD active surface	6 x 146 mm, 2D 6 x 292 mm, Ceph

ProCeph	
Pixel size	139 µm
Active surface	300 x 250 mm

Image sizes	SmartPan panorama, Adult: 13.0 x 29.1 cm, anatomical size 10.8 x 24.2 cm SmartPan panorama, Child: 11.2 x 25.2 cm, anatomical size 9.4 x 20.9 cm Ceph: 18 x 18 cm - 30 x 27 cm, anatomical size 15.9 x 15.9 cm - 26.5 x 23.9 cm ProCeph: 20 x 18 cm - 30 x 27 cm, anatomical size 17.7 x 15.9 cm - 26.5 x 22.1 cm
-------------	--

3D reconstruction computer

The 3D reconstruction computer is a high-performance Linux-based computer that acquires and reconstructs images from an imaging unit. This automatic reconstruction converts the original image data into the 3D volume, which is then transferred to the workstation (Romexis) and to the Romexis server for storage.

The 3D reconstruction computer is included in all deliveries of the KaVo ProXam 3D units..

Dimensions

The following figures illustrate the dimensions of the X-ray unit and the required minimum amount of space (grey area) for smooth operation.

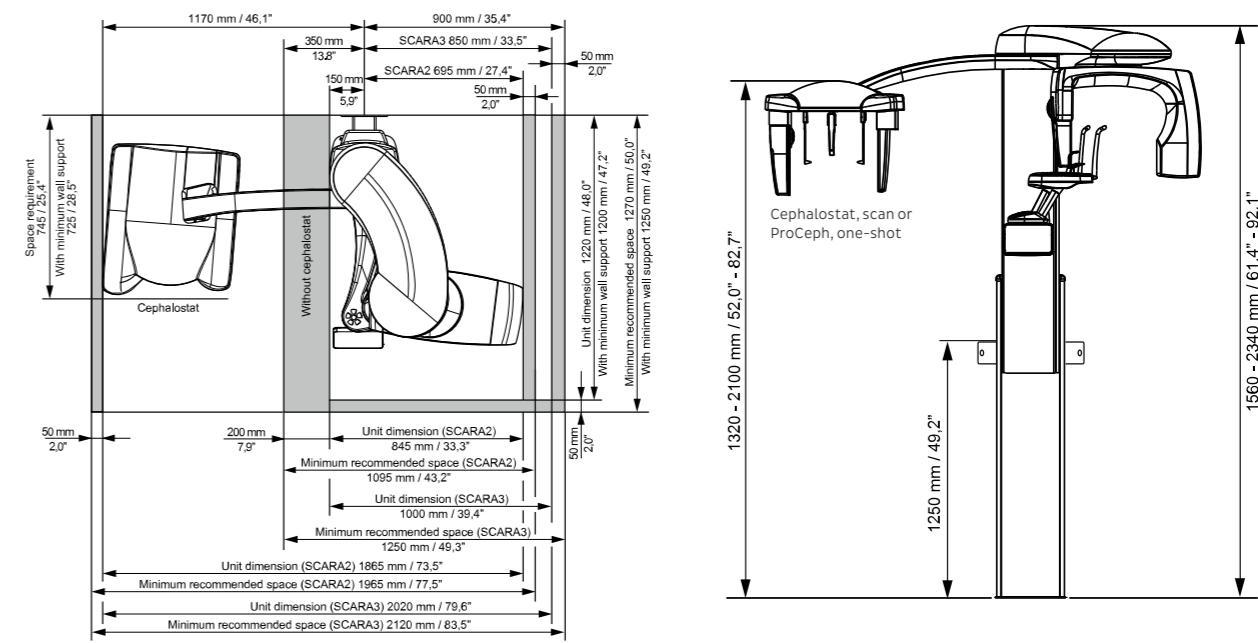

The maximum height is adjustable

Weight	119 kg (3D unit) 26 kg (scanning ceph X-rays) 20 kg (ProCeph)
Chin rest level	96-178 cm
Ceph ear pad height	97-179 cm

Technical specifications

KaVo ProXam 3DQ and 3DQ Pro CBCT X-ray unit

Product description

The KaVo ProXam 3DQ offers modern, three-dimensional maxillofacial imaging at the highest level, including numerous additional options for creating 2D panoramic, extraoral bitewing and cephalometric images. On the basis of extremely small voxel sizes, the KaVo 3D X-ray unit generates high-resolution and detailed CBCT images in diagnostically compelling quality and, thanks to the easy-to-use, intelligent setting modes, the image quality is impressive even at small radiation doses. In addition, this unit offers an even greater variety of preconfigured programmes for special diagnostic applications, especially in the ENT area. These include images of the sinus, nose, middle ear, petrous bone, cervical spine and airways.



2D Imaging

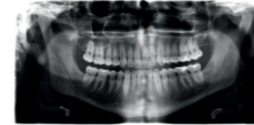

The **SmartPan system** uses the same 3D Sensor for 2D panoramic images. Also includes MultiView SmartPan, which creates nine panoramic images at different angles. MultiView SmartPan can be used in the panorama programmes.

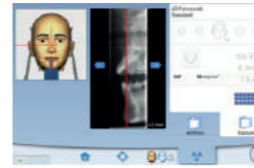

The unique **Auto Focus function** automatically positions the focal layer based on a low-dose Scout image of the centre of the patient's incisors. It uses points of reference in the patient's anatomy to calculate placement, allowing for error-free patient positioning.

Available: basic panorama programmes, horizontal and vertical segmentation, bitewing panorama programme.

2D Imaging



Scanning cephalometric X-ray or KaVo ProCeph for cephalometric images

Available resolution modes

Mode	Endodontics (optional)	High Resolution	High Definition (HD)	Normal	Low
Voxel size in μm	75	100	150	200/400	400/600

3D imaging programmes and volume sizes

3D standard programmes

Programme	Volume (child height), cm	Example	Mode/voxel
Tooth	$\emptyset 4 \times 5$ ($\emptyset 3.4 \times 4.2$)		Endo 75 μm HR 100 μm HD 150 μm N 200 μm d L 400 μm
	$\emptyset 4 \times 8$ ($\emptyset 3.4 \times 6.8$)		HD 150 μm N 200 μm d L 400 μm
Teeth	$\emptyset 8 \times 5$ ($\emptyset 6.8 \times 4.2$) $\emptyset 8 \times 8$ ($\emptyset 6.8 \times 6.8$) $\emptyset 10 \times 6$ ($\emptyset 8.5 \times 5.0$) $\emptyset 10 \times 10$ ($\emptyset 8.5 \times 8.5$)		HD 150 μm N 200 μm d L 400 μm
Jaw	$\emptyset 16 \times 6$ ($\emptyset 16 \times 6$) $\emptyset 16 \times 10$ ($\emptyset 16 \times 10$) $\emptyset 20 \times 6$ ($\emptyset 19 \times 6$) $\emptyset 20 \times 10$ ($\emptyset 19 \times 10$)		HD 200 μm N 400 μm d L 600 μm
Face**	$\emptyset 16 \times 9$ ($\emptyset 16 \times 9$) $\emptyset 20 \times 10$ ($\emptyset 20 \times 10$) (single) $\emptyset 16 \times 16$ ($\emptyset 16 \times 16$) $\emptyset 20 \times 17$ ($\emptyset 20 \times 17$)*		HD 200 μm N 400 μm d L 600 μm

Endo = Endodontie, HR = High Resolution, HD = High Definition, N = Normal, L = Low, d = Default
*stitched ** only with ProXam 3DQ Pro

Imaging Module

3D Imaging

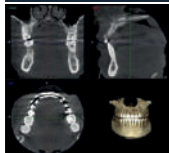

KaVo ProXam 3D provides high-resolution volumetric 3D images of the lower and upper jaw as well as the entire dental area.



3D endodontic imaging mode

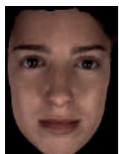

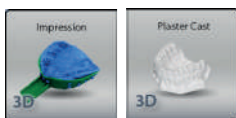

KaVo ProFace enables 3D photo shooting in the same session as the X-ray imaging or separately.

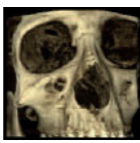
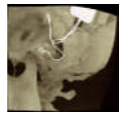
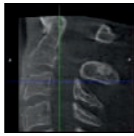
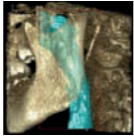

Model scan programs:
Special programs create high-precision 3D images of impressions and plaster casts

3D ENT programme

Programme	Volume (child height), cm	Example	Mode/voxel
Sinus	Ø10 x 8 Ø10 x 10 Ø10 x 14** Ø16 x 8 Ø16 x 10 Ø16 x 14** Ø20 x 8 Ø20 x 10 Ø20 x 14**		N Ø100 200 µm Ø200 400 µm d L Ø100 400 µm Ø200 600 µm
Nose	Ø8 x 8 (Ø6.8 x 6.8)		N 200 µm d L 400 µm
Middle ear	Ø4 x 5 (Ø3.4 x 4.2)		Endo 75 µm HR 100 µm HD 150 µm d N 200 µm
	Ø8 x 8 (Ø6.8 x 6.8)		HD 150 µm d N 200 µm L 400 µm
Middle ear pair	Ø4 x 5 (Ø3.4 x 4.2) Ø8 x 8 (Ø6.8 x 6.8)		N 200 µm d L 400 µm
Temporal bone	Ø8 x 8 (Ø6.8 x 6.8)		HD 150 µm d N 200 µm
Temporal bone pair	Ø8 x 8 (Ø6.8 x 6.8)		N 200 µm d L 400 µm
Cervical spine	Ø8 x 8 (Ø6.8 x 6.8)		N 200 µm d L 400 µm
Airways	Ø8 x 8 (Ø6.8 x 6.8)		N 200 µm d L 400 µm
Modelscan	Ø8x4		HD 100µm

Endo = Endodontics, HR = High Resolution, HD = High Definition, N = Normal, L = Low, d = Default * stitched ** only with ProXam 3DQ Pro

Sensor specifications
3D

Pixel size	127 µm
Active surface	15 x 15 cm

Sensor

CCD pixel size	48 µm
Image pixel size	48/96/144 µm (adjustable)
CCD active surface	6 x 146 mm, 2D 6 x 292 mm, Ceph
Ceph image size	300 x 270 mm

ProCeph

Pixel size	139 µm
Active surface	300 x 250 mm

Image sizes	SmartPan panorama, Adult: 14.6 x 33.0 cm, anatomical size 10.4 x 23.6 cm SmartPan panorama, Child: 12.7 x 28.7 cm, anatomical size 9.0 x 20.5 cm Ceph: 18 x 18 cm - 30 x 27 cm, anatomical size 15.9 x 15.9 cm - 26.5 x 23.9 cm ProCeph: 20 x 18 cm - 30 x 27 cm, anatomical size 17.7 x 15.9 cm - 26.5 x 22.1 cm
-------------	--

3D reconstruction computer

The 3D reconstruction computer is a high-performance Linux-based computer that acquires and reconstructs images from an imaging unit. This automatic reconstruction converts the original image data into the 3D volume, which is then transferred to the workstation (Romexis) and to the Romexis server for storage.

The 3D reconstruction computer is included in all deliveries of the KaVo ProXam 3D units.

Technical specifications

Classification	Medical Device Directive 93/42/EEC (Class IIb) RoHS: 2011/65/EU IEC 60601-1: Class I, Type B CISPR 11: Class B IP Classification: IP20
Generator	Constant potential, microprocessor controlled, resonant mode, operating frequency 80-160 kHz, Power factor corrector, meets the IEC 60601-2-7 standard
X-ray tube	D-054SB, D-059SBR or SXR 130-10-0.5 SC
Focal spot size	0.5 x 0.5 mm, according to IEC 60336
Total filtering	min. 2.5 mm Al + 0.5 mm Cu
Anode voltage	2D: 60-84 kV Ceph: 60-84 kV 3D: 60-90 kV
Anode current	2D: 1-16 mA Ceph: 1-16 mA 3D: 1-14 mA (Steps with the R20 series: 1, 1.1, 1.25, 1.4, 1.6, 1.8, 2.0, 2.2, 2.5, 2.8, 3.2, 3.6, 4.0, 4.5, 5.0, 5.6, 6.3, 7.1, 8.0, 9.0, 10.0, 11.0, 12.5, 14.0, 16.0)
Exposure time	2D: 2.7-16 s SmartPan: 2.5-15.6 s 3D: 3-36 s
Scan time	14-37 s
Scan angle	200° / 360°
SID	2D: 574 mm Ceph: 1700 mm 3D/SmartPan 90kV: 600 mm 3D/SmartPan 120kV: 632 mm
Focus-skin distance	min. 150 mm
Enlargement	SmartPan: 1,4 3D: 1,8 / 1,43 / 1,42 / 1,40 / 1,38
Panorama image size	SmartPan: 190 x 100 mm
Line voltage	100-240 V- ±10%, 50 or 60 Hz Power Factor Corrector
Line current	8-15 A

Dimensions

The following figures show the dimensions of the X-ray unit and the minimum space required (grey area) for smooth operation.

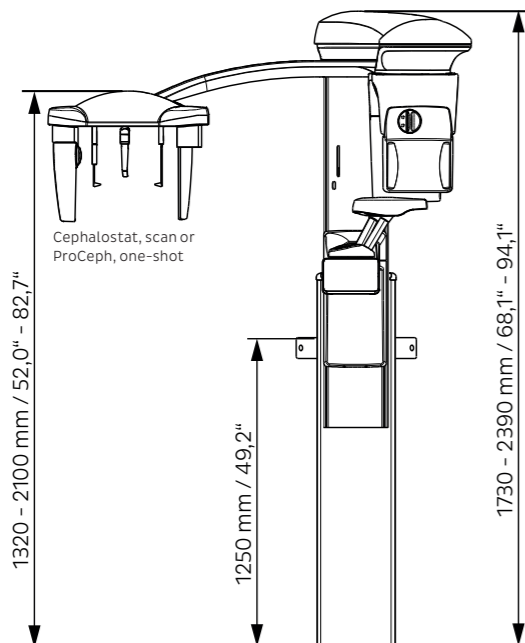
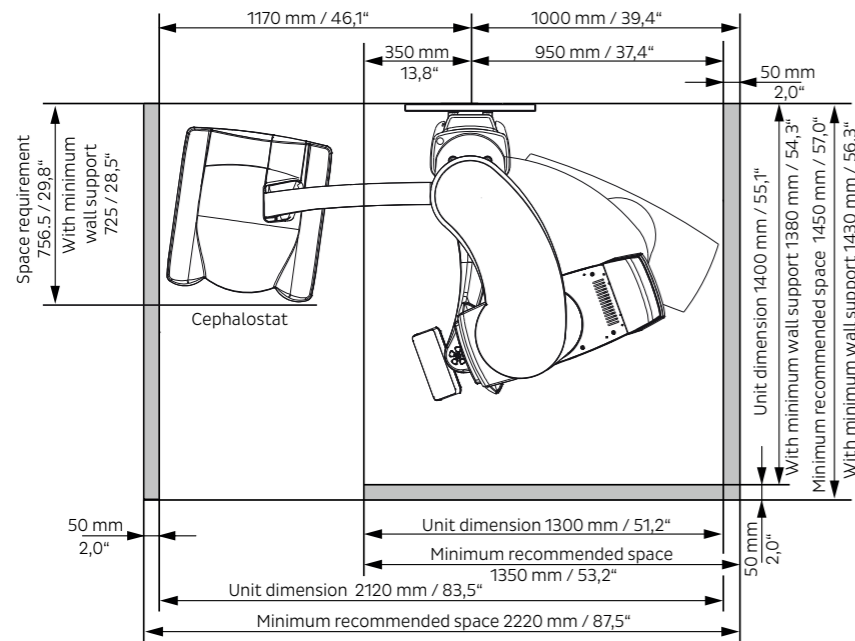

The maximum height is adjustable

Weight	141 kg (3D unit) 26 kg (Ceph) 20 kg (ProCeph)
Chin rest level	97-171 cm
Ceph ear pad height	97-179 cm

Romexis Technical specifications

Example installation

Included in scope of delivery: 3D unit with 3D reconstruction server

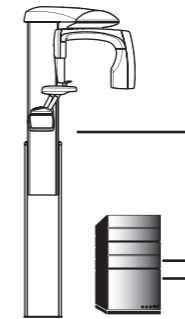

Minimum set-up: Client workstation and database server
 • Romexis 3D Explorer
 • Database server
 • Romexis Image database
 The client workstation and database server can reside on separate computers.

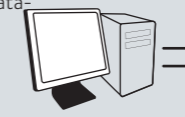

Ethernet

Additional equipment: Additional diagnostic workstations with different software configurations
 Romexis tools:
 • 3D Explorer
 • 3D cross-section module
 • 3D TMJ module
 • 3D Implant Planning module
 • DICOM module

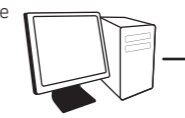
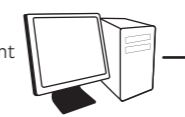

Technical specifications

Supported 2D modalities	Intraoral, panorama, cephalometric X-ray, linear 2D tomography, photos, layer recordings (CBCT and panoramic layers)
Supported 3D modalities	3D CBCT, 3D photo, 3D surface scan
Supported photo sources	Intraoral camera Digital camera or scanner (import or TWAIN images)
Operating systems	Windows 8.1 Pro (64-bit) / Windows 10 Pro (64-bit) Windows Server 2012 to Windows Server 2019 macOS Mojave (10.14)* / macOS Catalina (10.15)* For more information, see Romexis system requirements
Image formats	JPEG or TIFF (2D images) DICOM (2D and 3D images) STL, OBJ, PLY (3D surface models) DICOM, TIFF, JPEG, PNG, BMP, STL, PLY (imports/exports)
Image size	2D X-ray images: 1-9MB 3D X-ray images: typically 50MB -1GB
Installation options	Client server
DICOM 3.0 support	DICOM import and export DICOM DIR Media Storage
Interfaces	TWAIN Client PMBridge (patient data and images) VDDS (patient data and images) InfoCarrier (patient data)
Integration of third-party software	Dolphin Imaging Nobel Clinician Implant Straumann co DiagnostiX Cybermed N - Liten 3D Diagnostics service 360 imaging service

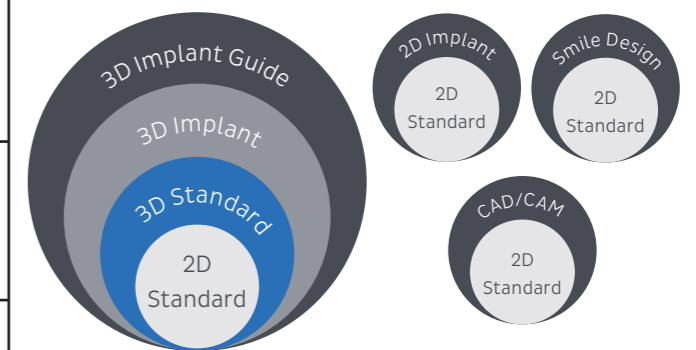

Index

KaVo	Page
CBCT	44
Ceph imaging	42
Cephalostat	52
Extraoral	40
Imaging plate	28
Implant workflow	63
Interview	10
Intraoral	16
Intraoral scanner	32
Intraoral emitter	18
KaVo ProXam 2DQ ProXam 2DQ Pro	38
KaVo ProXam 3D	44, 50
KaVo ProXam 3DQ ProXam 3DQ Pro	44, 51
KaVo ProXam iX	18
KaVo ProXam iS	22
KaVo ProXam iP	26
KaVo ProXam iOS	30
Maintenance	70
PSP scanners	28
Panoramic shots	38
Romexis	54
Service	69
Small X-ray	18
Software	55
Technical specifications	74

Dental Excellence in every area

What our brand represents

KaVo is a long-established, dependable manufacturer, and always will be. We and our products have stood for the highest quality and reliability for over 100 years, so our customers can concentrate on what's important.

KaVo is adept and uncompromising when it comes to combining essential requirements, ergonomics, the highest standards of hygiene and design to create the best overall package. Thanks to our perfect interplay of dynamism and expertise, we're always at the cutting edge.



KaVo dental units -
Invest in your own health



KaVo instruments -
Feel the difference



KaVo Imaging -
See more, plan better



Dental training -
Excellent learning



The products, equipment and services shown and described in this catalogue are not available in every country. The information given here reflects the knowledge available at the time of printing. KaVo Dental GmbH accepts no liability for deviations in colour or form in the illustrations, or any errors or misprints, and reserves the right to make changes to the brochures at any time.

KaVo, ESTETICA, uniQa, amiQa, Primus and Lumina are registered trademarks of KaVo Dental GmbH.