



DigiPla 80/DigiPla 90

Plasma Separator

Service Manual

Version E

Contents

Contents	i
Intellectual Property	i
Version Information	i
Suitable Users	ii
Maintenance Service	iii
Sales Service Department	iii
Statement	iii
1 Preface	1-1
1.1 Symbols Meaning.....	1-1
1.2 Symbols on Equipment.....	1-1
1.3 Safety Codes.....	1-2
1.3.1 Electrical Safety.....	1-3
1.3.2 Machinery Safety.....	1-3
1.3.3 Personnel Safety.....	1-4
1.3.4 Others.....	1-4
2 Installation Preparation	2-1
2.1 Expected Use.....	2-1
2.1.1 Product Description.....	2-1
2.1.2 External size and Weight.....	2-1
2.2 Specification and Conditions of Installation.....	2-1
2.2.1 System Environment.....	2-1
2.2.2 Electrical requirements.....	2-2
2.3 Facility Requirements.....	2-2
2.3.1 Space Planning.....	2-2
2.3.2 Network Requirements.....	2-3
2.3.3 Installation Confirmation.....	2-3
3 System Installation	3-1
3.1 Brief Introduction to Installation.....	3-1
3.2 Unpacking and Inspection.....	3-1
3.2.1 Unpacking procedures.....	3-1
3.2.2 Inspection.....	3-1
3.3 Whole Set Installation.....	3-2
3.3.1 Front View.....	3-2
3.3.2 Side and Rear View.....	3-4
3.3.3 Installation.....	3-5
3.4 Peripheral Installation.....	3-10

3.4.1	PC Data Management Software	3-10
3.4.2	ID scanner	3-10
3.4.3	UPS (Uninterrupted Power Supply).....	3-12
3.5	System Configuration	3-12
3.5.1	Power on and operation	3-12
3.5.2	System Introduction.....	3-12
3.5.3	Function set.....	3-21
4	Function Inspection and Test	4-1
4.1	Preparation.....	4-1
4.2	Equipment Status Inspection.....	4-1
4.2.1	Running status	4-1
4.2.2	Working Environment.....	4-1
4.3	Regular Check.....	4-2
4.3.1	Check Procedure.....	4-2
4.3.2	Inspection Contents	4-2
4.4	Function Inspection.....	4-3
4.4.1	Inspection Procedures	4-4
4.4.2	Inspection Contents	4-4
4.5	Performance Test	4-5
5	Software Upgrade	5-1
5.1	System Software	5-1
5.1.1	Upgrade Necessary	5-1
5.1.2	Pre-upgrade Installation	5-1
5.1.3	Programming Software	5-2
5.2	Control Software.....	5-3
Upgrade Equipment.....		5-3
5.2.1	Programming Software	5-3
6	Hardware System.....	6-1
6.1	System Composition	6-1
6.1.1	Human-computer Interaction System	6-2
6.1.2	Collection System.....	6-3
6.1.3	Power System.....	6-4
6.2	Function Board Card Introduction	6-5
6.2.1	System Board	6-6
6.2.2	Control Board, Driver Board and Backplane.....	6-7
6.2.3	DC Power Board.....	6-10
6.3	Structure Dismounting	6-11
6.3.1	Dismounting Tools.....	6-11
6.3.2	Marking Instruction	6-11
6.3.3	Personnel requirements	6-12
6.3.4	Preparation for Dismounting	6-12
6.3.5	Dismounting of Host Assembly.....	6-12

6.3.6	Board Card Dismounting.....	6-15
6.3.7	Dismounting of the other parts.....	6-20
7	System Diagnosis and Support	7-1
7.1	Starting Up.....	7-1
7.2	Components Fault and Test.....	7-1
7.2.1	Tools required for Maintenance.....	7-1
7.2.2	Power Pack.....	7-1
7.2.3	Weigher Startup to enter the weigher calibration interface or debug interface:.....	7-2
7.2.4	Cuff.....	7-2
7.2.5	DPM.....	7-3
7.2.6	Line Sensor.....	7-3
7.2.7	Valve.....	7-3
7.2.8	Pump.....	7-4
7.2.9	Centrifuge Assembly.....	7-5
7.2.10	Air Detector.....	7-6
7.3	Alarm and Abnormal Information.....	7-7
8	Care and Maintenance	8-1
8.1	Summary.....	8-1
8.1.1	Purpose.....	8-1
8.1.2	Tools, measuring equipment and Disposable.....	8-1
8.1.3	Care and Maintenance Frequency.....	8-2
8.2	Cleaning System.....	8-3
8.2.1	Cleaning Procedures.....	8-3
8.2.2	Content.....	8-3
8.3	Maintenance Check.....	8-6
8.3.1	System Function.....	8-6
8.3.2	Inspection of Peripherals and Fittings.....	8-6
8.4	System Maintenance.....	8-7
8.4.1	Electrical Safety Maintenance.....	8-7
8.4.2	Machinery Safety Maintenance.....	8-8
9	Appendix	9-1
9.1	Setting of Centrifuge Driver.....	9-1
	Calibration Record.....	9-2
9.2	Spare Parts View.....	9-4
9.3	Spare Parts List.....	9-11

Intellectual Property

The intellectual property of this operator's manual and its corresponding products belongs to Sichuan Nigale Biotechnology Co., Ltd. (here in after refers to as "Nigale").

Without prior written consent of Nigale, any person or organization may not copy, modify, or translate any part of this service manual.



, and **NIGALE** are registered trademarks or trademarks of Nigale.

Version Information

The version number of this service manual is subject to upgrade due to the change of software or technical specifications without prior notice. The version information of this service manual is as follows:

Version Number	Issue Date Year/month	Reasons for Revision
A	2020.10	First edition
B	2020.11	Updated Parts View and List, Safety test method
C	2021.12	Section 7.2.8 adds roller failure phenomena and roller maintenance inspection items
D	2022.4	<ol style="list-style-type: none">1. Valve sensor adjust method.2. Centrifuge cover check.3. Centrifuge speed set 7500/7000.4. Add spare part: Cover with barrel.5. KIT 3.5 programmer can be used to update
E	2023.6	<ol style="list-style-type: none">1. Add anticoagulant weigher and its calibration.2 Change versions of control board, driver board, and communication board, centrifuge driver.

		3. Update the upgrade method of the upper computer
--	--	--

© 2016 Sichuan Nigale Biotechnology Co., Ltd. All Rights Reserved

Suitable Users

This service manual is suitable for customer service engineers, authorized maintenance personnel and after-sales service representatives who are responsible for the product maintenance.

Maintenance Service

Scope of free services:

All products according with the warranty service regulations can enjoy free services.

Scope of paid services:

- 1 For all products exceeding the warranty service regulations, services will be charged by Nigale.
- 2 Even under the warranty period, maintenance services caused by the following reasons will be charged: man-made damages; misoperation; network voltage exceeds the prescribed limit of product; irresistible natural disaster; replace parts or Disposable without permission of Nigale or maintain the product by personnel not authorized by Nigale.

 Warning: If each plasma station, hospital or organization responsible for using of this equipment cannot provide a satisfactory repair/maintenance plan. It may cause abnormal equipment failure, or even may endanger human health.

Sales Service Department

Sales service department of Sichuan Nigale Biotechnology Co., Ltd.

Address: 4th F, No.2 Factory Building, Shiyang Industrial Park, No.55, Section 5th, Qingyun village, Hi-Tech District, Chengdu.

Zip Code: 610041

24-hours Service Hotline (China Mainland Only): 400-606-9696

Fax: +86 28-85130655

Statement

This service manual introduces our products based on the most complete configuration, so some contents may not apply to the product under your maintenance. Please direct any inquiries to the after-sales service department of the company.

Please read through this service manual carefully before product maintenance and make sure the contents are fully understood to ensure correct maintenance work and avoid damage of products or personal injury.

1 Preface

This chapter mainly describes a series of safety information adopted by the system and gives detailed introduction to safety signs and symbols used on the equipment.

1.1 Symbols Meaning















This service manual may use the following symbols **⚠ Danger**, **⚠ Warning**, **Caution** and **Prompt** as instructions regarding safety and other important matters. Specific meanings are as follows:

Symbol and vocabulary	Meaning
⚠ Danger	It indicates there will be an imminently hazardous situation which, if not avoided, will result in death or serious injury.
⚠ Warning	Personal injury may occur in the place, including warn the operator against potential danger.
Caution	Provide additional information may be useful to the operator at different steps. Please note that it may include non-critical information, however, the operator should always review background information.
Prompt	Inform conditions that may damage the product, affect the result or cause unnecessary alarms.

1.2 Symbols on Equipment

The following table describes the locations of safety signs, warning signs and general symbols used on the equipment and related important information provided by these symbols respectively, please read carefully and remember them.

No.	Symbol	Definition	Location
1		BF-type device	On labels and above cuff connectors

No.	Symbol	Definition	Location
2		Caution: Please operate according to the operator's manual, so as to avoid safety accidents.	On the upper cover of the host closing to the centrifuge switch
3		High voltage: There are high-voltage electric fields nearby the power supply, so keep away from the electrified part of the device or electrified maintenance device.	High-voltage label —On the rear cover of the power pack
4		Read the information after use	On product labels
5		Product's serial number	
6		Product's manufacturing date	
7		This electronic information product contains some toxic and harmful substances, and can be used assuredly within 20 years of environment-friendly use period, after which, it shall be recycled.	
8		AC (alternating current)	
9		Manufacturer information	
10		Power off	
11		Power on	
12		Serial port	At the bottom left of the rear cover of the host
13		Network interface	
14		USB interface	
15		Fuse	Underneath the power switch

1.3 Safety Codes

To ensure the safety of users and operators, please strictly abide by the following safety codes when using the product.

 Danger: Do not use the product in environment with inflammable gases (such as anesthetic gases, oxygen and hydrogen) or flammable liquid (such as ethanol), or there may cause an explosion.

1.3.1 Electrical Safety

- ⚠Warning:**
1. It is necessary to connect the power plugs of this product as well as its external connected devices to the power socket on the wall directly, and the socket must be well grounded and meets the rated power requirement. Using a multi-function socket may affect the ground connection and make the leakage current exceed safety requirements. Be sure to use the power cable provided together with the product.
 2. Before cleaning the product, please shut down the product's power switch and unplug the power plug to avoid electrical shock hazard.
 3. In maintenance and assembly process, it is necessary to confirm other wires are connected correctly before connecting the power cable, otherwise the machine might be burned out due to hot plug.
 4. Do not use this product in areas where water may enter the case, because this product is not equipped with any waterproofing equipment. To avoid risk of electric shock, do not pour any liquid on the product or let the liquid flow into the product.

- Caution:**
1. It is prohibited to directly unplug the product's power plug when the power switch is not shutting down, or this may cause damage to the product or electrical shock.
 2. When using this product for performance testing, please be sure that the product is safe from the interference of electromagnetic radiation.
 3. Avoid direct hand contact closing to the electrostatic sensitive area, if necessary, please wear electrostatic protective gloves.

1.3.2 Machinery Safety

- ⚠Warning:**
1. When the product has to be carried, please take down the bag weigher and hold the handle.
 2. Don't let the display or the structural parts of the machine knocked or pressed to avoid damage.

- Caution:**
1. Don't put overmuch vibration on the product (e.g., when handling equipment) to prevent the product from falling down, crashing, strong variation or other damages caused by external mechanical forces.
 2. Ensure that the product is in a horizontal position when it is installed.

1.3.3 Personnel Safety

Caution :	<ol style="list-style-type: none">1. Operators are neither allowed to open the shell or the panel of this product nor disassembling the machine.2. Maintenance services must be completed by professional maintenance staffs authorized by Nigale.3. Only the personnel specially trained by Nigale can maintain the equipment.
---------------------	---

1.3.4 Others

Caution :	Please refer to the Product Manual for detailed instructions about the plasma separator and other information thereof.
---------------------	--

2 Installation Preparation

2.1 Expected Use

2.1.1 Product Description

DigiPla80/DigiPla90 plasma separator adopts advanced computer technology, peristaltic pump technology of transmitting pollution-free fluid and blood centrifugal separation technology, to complete raw material plasma collection for clinical and biological products.

Applicable people are plasma providers meeting the requirements of the Blood Donation Law of People's Republic of China.

2.1.2 External size and Weight

Name	High(mm)	Length(mm)	Width(mm)	Weight(Kg)
Value	770	540	510	29

2.2 Specification and Conditions of Installation

2.2.1 System Environment

Item	Operating Environment	Storage and Transportation Environment
Temperature	10°C~30°C	-20°C~55°C
Humidity	≤70%	≤93%
Atmospheric pressure	86kPa~106kPa	50kPa~106kPa

⚠Warning: Do not use, store or transport the product except for in the specified environmental conditions.

Caution	Please do not install the plasma separator in the following areas:
:	<ol style="list-style-type: none"> 1. Near heat sources 2. High-humidity atmosphere 3. With the existence of flammable gas

2.2.2 Electrical requirements

2.2.2.1 Requirements to Power Supply

Supply voltage:	Frequency	Output power	Fuse
~230 V / ~115V Default: ~230 V	50/60Hz	500VA	T 4A H 250V, 5×20

2.2.2.2 Requirements to Stabilized Power Supply

Due to varying degrees of stability of power supply from place to place, users are suggested to use stabilized power supply with superior quality and performance.

2.2.2.3 Grounding Requirements

The power cord of the machine is a triaxial cable, wherein the ground protection terminal is connected with the ground protection of the power system. Please make sure that the ground protection of the power system operates smoothly.

 Warning:	<p>Please connect the equipment to a socket with separate fuse and protection switches. If it shares the same fuse and protection switch with other equipment, trip might be resulted in once the machine break down or overcurrent occurred or a momentary impulse current generated during boot.</p>
---	---

2.3 Facility Requirements

2.3.1 Space Planning

Please put the product with necessary accessories in the appropriate position for convenient operation:

1. Please put the product in a well-ventilated environment or an air conditioned room;
2. The door of the room should be no less than 0.8m wide to move equipment into the room easily;
3. A space of 0.2m must be reserved around the equipment for effective heat dissipation;

2.3.2 Network Requirements

The product supports wireless or wired LAN connection.

In the process of the software configuration management (PC management software) of the product, the network connection of the product should be confirmed: the wired connection is to connect the Ethernet port at the bottom left of the rear cover of the host with the corresponding port by network cables (twisted pair); and the wireless connection is to communicate with the wireless router via an internal WIFI module (on the system board card) of the product. At the same time, it is necessary to confirm that the user's network configuration matches the product requirements.

2.3.3 Installation Confirmation

Before installation, please confirm:

1. The language used by the installation site and the country
2. The power frequency voltage used by the installation site and the country
3. Other settings of the installation site and the country different from the default value of the manufacturer
4. The product configuration and optional fittings

Please confirm the above information before installation to facilitate correct settings of the equipment based on general settings of the installation site and the country.

3 System Installation

3.1 Brief Introduction to Installation

Installation tools: cross screwdriver (attached file)

3.2 Unpacking and Inspection

3.2.1 Unpacking procedures

1. Take down the upper cover of the packing box;
2. Take out the cover, the cushion block contains attached files and accessories.
3. Use the handles on both sides of the product to lift the plasma separator out from the box.

3.2.2 Inspection

1. Please check objects in the box one by one against the packing list to ensure that no component is missed, wrong or damaged;
2. Please make sure the machine was not damaged in the process of storage and transportation, the appearance of the machine has no stain, damage, indentation or score break. Please direct any discrepancy to the after-sales service department of Nigale.

3.3 Whole Set Installation

3.3.1 Front View

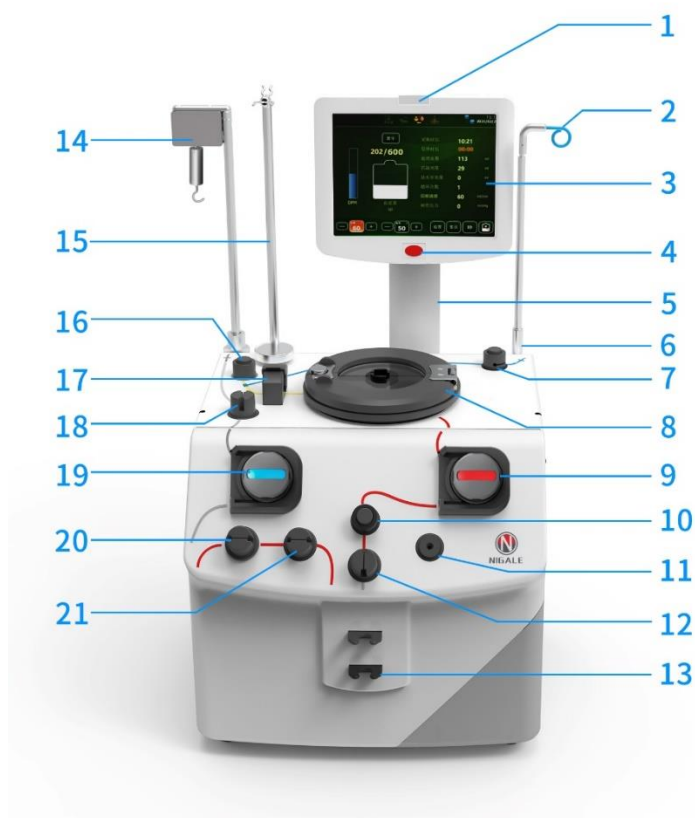

No.	Part Name	Purpose
1	Indicator light	Send light prompt when there is prompt information or an alarm.
2	Saline pole	Hang saline container.
3	Display screen	Display image and parameters and other information.
4	Stop Key	Stop the separator operation, as well as the pump and centrifuge.
5	Display arm	Connect to the display and cabinet.
6	Pole button	Fix the pole.
7	Saline valve	Control the open and close of saline pipeline.
8	Centrifuge	The centrifuge will drive the centrifuge bowl rotating at high speed when operating.

9	Blood pump	Transfer anticoagulated blood and blood components in the pipeline between donor and centrifuge bowl.
10	Blood valve	Control the open and close of blood pipeline.
11	Donor pressure monitor (DPM)	Monitor the pressure in the blood pipeline of donor during draw and return phase, adjust the pump speed according to pressure. The pressure change is displayed on the LCD screen on bar chart.
12	Blood line air detector	Monitor the pipeline between the blood filter and centrifuge bowl.
13	Bracket for blood filter	Support and fix the blood filter.
14	Anticoagulant pole	Hang the anticoagulant container.
15	Weigher	Can be assembled with bottle or bag weigher, It can monitor the net weight of plasma in collection bottle/bag, and the unit is in g/ml.
16	Plasma valve	Control the open and close of plasma pipeline.
17	Line sensor	Detect the overflow of red blood cells in plasma collection process.
18	Anticoagulant line air detector (ALAD)	Monitor the air in the anticoagulant pipeline.
19	Anticoagulant pump	Transfer anticoagulant in the pipeline between anticoagulant bag and blood collection joints.
20	Donor line air detector 1 (DLAD1)	Monitor the air in the pipeline between the donor and blood filter.
21	Donor line air detector 2 (DLAD2)	Monitor the air in the pipeline between the donor and blood filter.

3.3.2 Side and Rear View

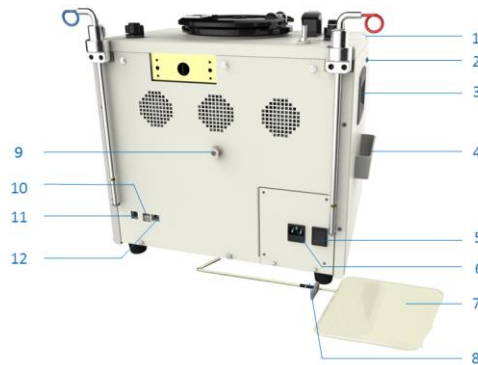

No.	Part Name	Purpose
1	Protective cap slot	Fix the protective cap of needle
2	Donor light	Blood flow pressure indicator light : Green lamp on: moderate pressure. Green lamp flashing: low pressure, the blood pump entering into the automatic speed control state, but in an acceptable range, reminding the donors making a fist. Red lamp on: pressure too low, the blood pump stop and low pressure alarm.
3	Handle	Convenient for separator moving
4	Cuff trough	Place cuff
5	Power switch	Turn on/off the power
6	AC power input socket	Connect with the system power line
7	Waste liquid bag	Collect the leaking liquid in centrifuge
8	Drain connector	Connect with waste bag at the leakage collector exit of separator
9	Cuff Connector	Connect with pressure cuff
10	USB interface	Connect with external equipment such as code scanner
11	Serial port	Maintain and test product
12	Ethernet port	Connect with the network

3.3.3 Installation

3.3.3.1 Installation of Display Components

 —Removed parts (screw for example)

 —Direction of the move

 —Installed parts

1. Preparation:

After the rising and fixture of anticoagulant poll and Saline poll, screwdriver is used for the removal of the 5 screws (M4×8) on the rear cover of the host and the 4 sunk screws (M4×8) on the host shelf.



Figure 3-1 Removal of the Host Rear cover

2. Installing Display Component

- (1) Hold the component bracket with one hand, and put the communication cable coming from the bracket through the round hole in the back of the host with the other hand.



Figure 3-2 Communication Cable Threading

- (2) Use the screw in 1 to install the display component onto the host shelf.



Figure 3-3 Display and Host Connection

- (3) Connect the communication cable to the communication board on the rear cover, fix the grounding line of the communication cable on to the M3 stud on the rear cover and also check whether the fan wire connector is well connected to the control communication cable plug.

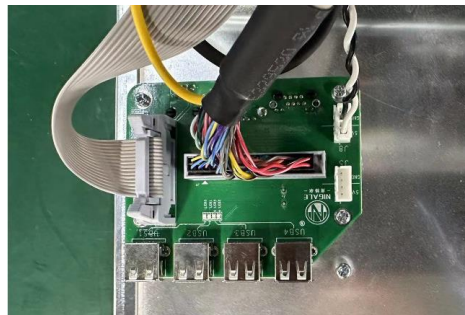
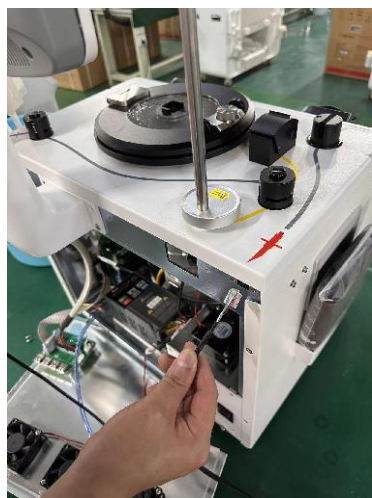

Figure 3-4 Communication Board wiring diagram

- (4) AC weigher installation

A: Route the cable through the hole in the rack



B. After pulling the cable to the length shown, attach screws and gaskets to the mounting holes to secure the pole with anticoagulant weigher.

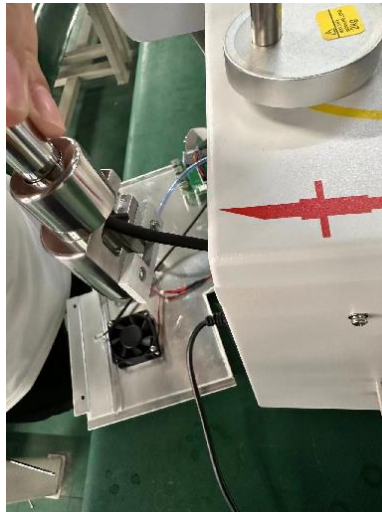

C. Plug the anticoagulant weigher cable into the control board as shown.

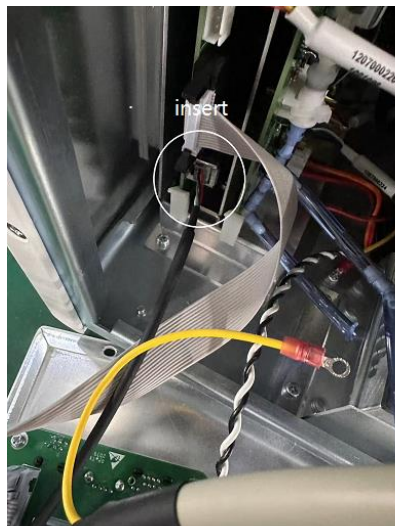

(5) Connect the rear cover of the host to the host shelf with the screw in 1.



Figure 3-5 Host Rear Cover Installation

3.3.3.2 Installation of Accessory

(1) Connection of cuff components

When the cuff connector pressing-piece on the host rear cover is pressed, insert the connector into the cuff hose and the connection is done after the sound of clickety-clack is heard.



Figure 3-6 Cuff Component Connection

(2) Installation of weighers:

As showed in the pictures (bag weigher or bottle weigher)



Figure 3-7 Cuff Connection

(3) Installation of barcode scanner bracket

Remove the M6×10 sunk screw connecting bracket and cork base on the bracket components.

Connect the 2 M3x10 sunk screws on the cork base to the hole on the right cover of the host.

Then connect the bracket to the cork base.

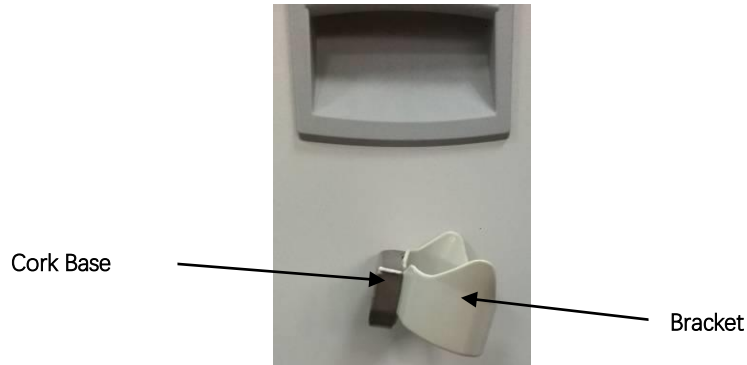
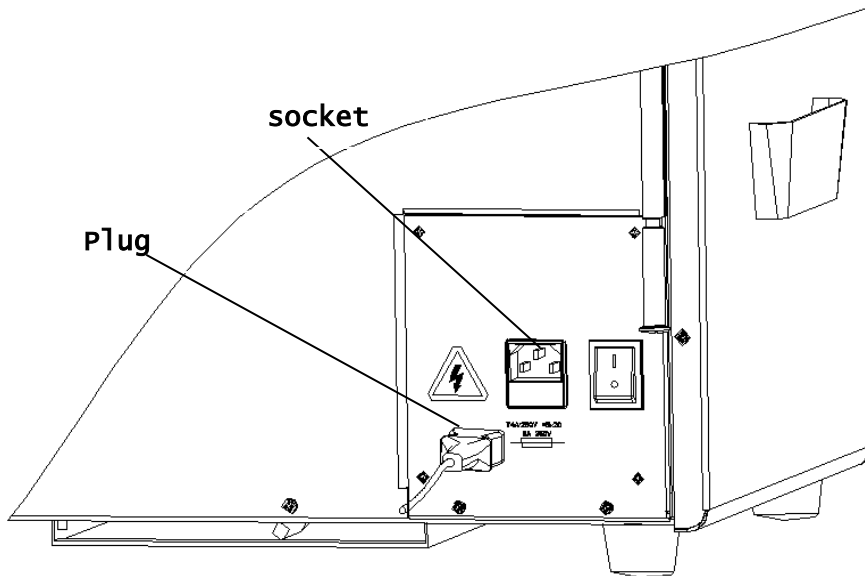

Figure 3-8 Barcode Scanner Bracket Connection

3.3.3.3 Install power cable

Plug the power cable into the socket as shown:



3.4 Peripheral Installation

3.4.1 PC Data Management Software

The PC data management software is a software system used to manage the collection result data of the plasma separator.

Copy the DigiPla DMS folder from the CD-ROM to the local hard disk. Just double-click DigiPlaDMS.exe to open the software. Before installation, please ensure that there is sufficient local hard disk storage space.

PC Minimum Configuration	
Operating system	Windows XP / Windows 7
CPU	1GHz
Memory RAM	512M
Hard disk storage	20G

3.4.2 ID scanner

Plasma Separator supports to connect an ID scanner in USB connection mode, such as barcode scanning gun, which is used to complete the input of ID of personnel, Disposable and accessories configured in the system.

1. According to the structure chart of a scanner as shown, key positions of an ID scanner comprises: an LED indicator, a scan window and a scan trigger switch;

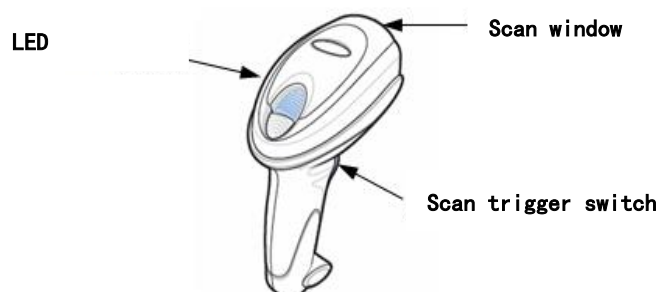

2. Connect one end of the scanner cable and the scanner to a socket underneath a handle;

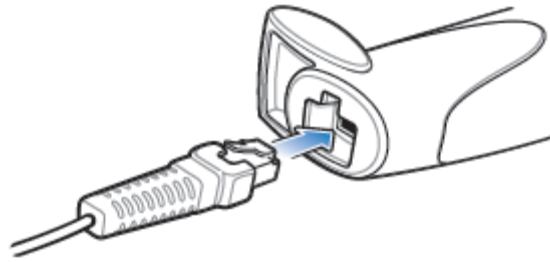

3. Connect the other end (USB terminal) of the cable to a USB interface of the equipment, now the indicator light of a barcode scanner is on;

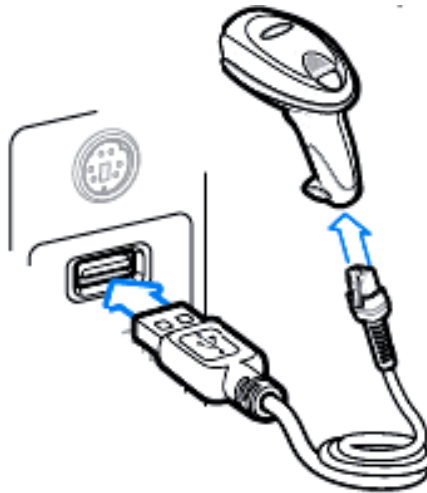

4. Press the scanning trigger switch to scan the barcode information when the equipment is operating. Please refer to the barcode scanner instructions for other application methods;
5. Put the well-connected scanner on a bracket at the right of the host (as shown in the figure) to avoid breaking the scanner accidentally.

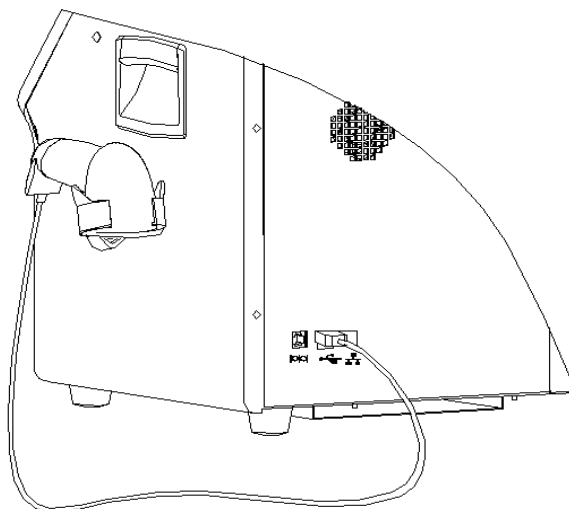

3.4.3 UPS (Uninterrupted Power Supply)

When the power supply system fails, the Plasma separator can be connected with the external device's UPS (Uninterrupted Power Supply), so as to continue the operation of plasma separator. For operating hours and use method of UPS, see the operator's manual of the product. The connection mode is as shown in the following figure:

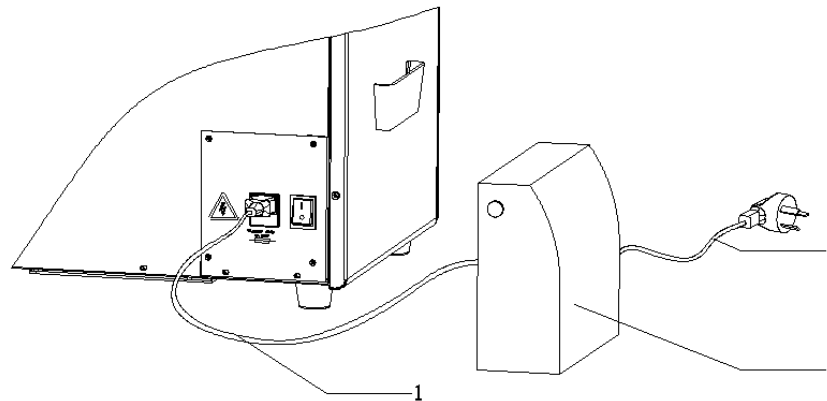

Connect the power plug of power cable 1 of the plasma separator to the socket of UPS 2, and connect the power plug of power cable 3 of the UPS to the power socket on the wall.

3.5 System Configuration

3.5.1 Power on and operation

1. Connect the power supply plug to the AC power supply and confirm the connections of the system and the optional parts of the product are correct;
2. Turn on the power switch at the bottom right of the rear side of the case and then a startup screen will be displayed after starting the system normally: display the Logo of the Company, make a sound of boot and give a boot light (blue, light on for about 40 seconds);
3. Power-on self-test: self-test the components;
4. After finishing the self-test, the system enters to an interface of ready state.

3.5.2 System Introduction

After a series of initialized actions, the system will go straightly to the power-on self-test interface after startup, and self-test components according to the progress prompt on the interface, in the end of the self-test, participate in to complete switch check of the centrifuge manually according

to the interface prompt, by this time the progress reaches 100% and the system enters into the interface of ready state.

3.5.2.1 Collection Process

1. Collection Process



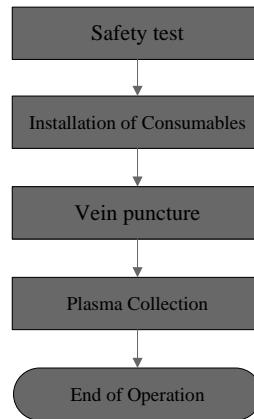





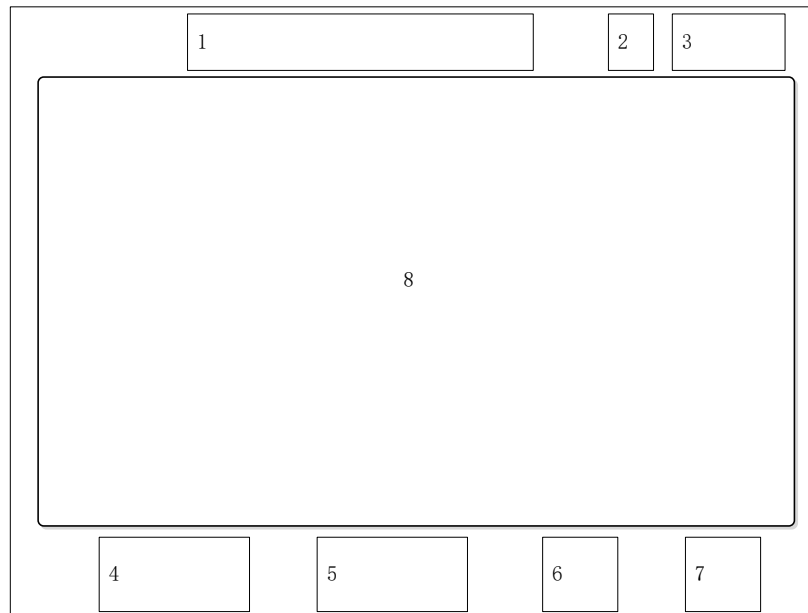









Press the button of **Draw** at the interface of ready state to enter the plasma collection process, wherein the operation procedures are as follows:



The ID information and collection parameters can be modified or set in plasma collection stage.

2. Collection Interface



No.	Display Content Description
1	<p>Current collection status of the system: Installation of Disposable → collection preparation → collection process → finish collection</p> <p> Disposable installation stage  Collection preparation stage  Collection stage  Centrifuge braking  Return stage  Disposable removing stage. The current lighted icons represent the current state.</p>
2	<p>Current networking status of the system: wired connection success/failure  / , wireless connection success/failure  / .</p>
3	<p>Current date and time of the system.</p>
4	<p>Quick setting button of the Pump, including On  / Off , and speed up  / slow down  (adjust the step value to 5).</p>
5	<p>Quick setting button of Cuff, including On  / Off , and add  / reduce  (adjust the step value to 5).</p>
6	<p>Setting button. Click this button to pop up a window for setting collection parameters: Click here and the window pops out; then set the current collection process parameter.</p>
7	<p>ID button. Pop up a window to query or modify the ID information of personnel, Disposable and accessories and other information. The ID input is a configured item.</p>
8	<p>Process stop button. End the plasma collection process.</p>
9	<p>Main interface. It displays a dialog box, real-time service data and status information.</p>

3.5.2.2 System Configuration

Click **Configuration** in the ready interface, input the set password (initial password is 8888) to enter the user configuration interface and the interface consists of the following element: Language, Unit, Set Time, Set Parameters, Set Password and Log.

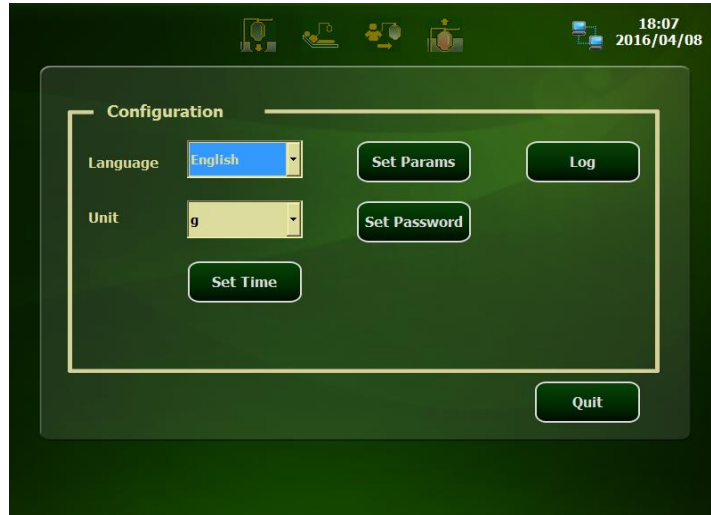

1. Language: select language of the user interface;
2. Unit : select the unit of measurement for the product under collection, g/ml;
3. Set Time: modify or set the system time;

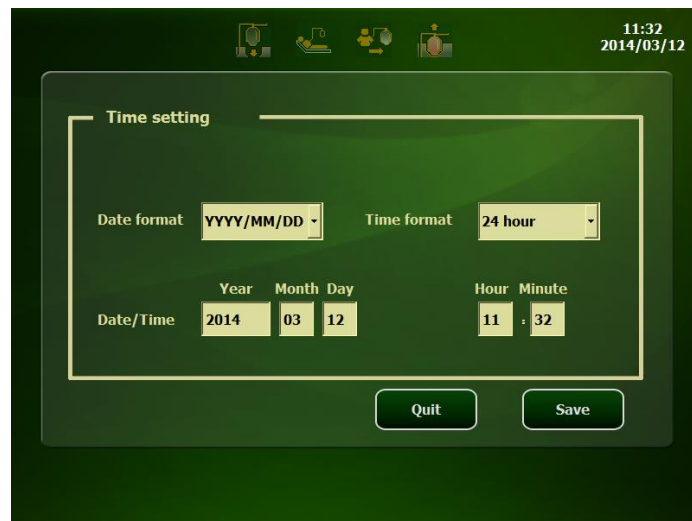

4. Set Params: set general collection parameters according to user requirements;

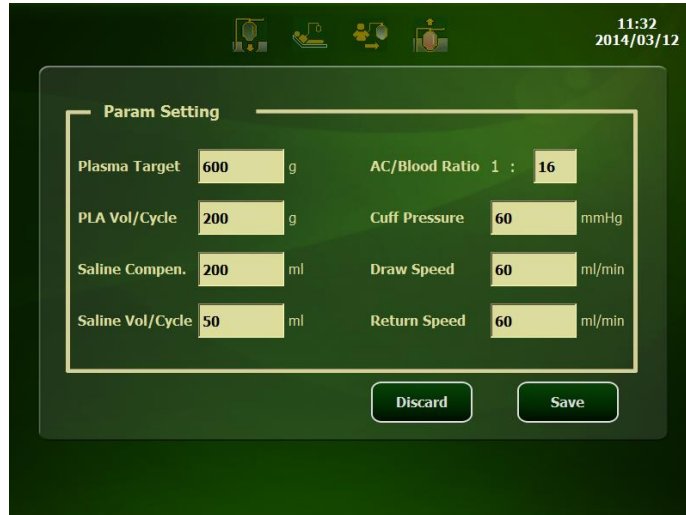

DigiPla 80



DigiPla 90

5. Set Password: change the configured password (original password is 8888);

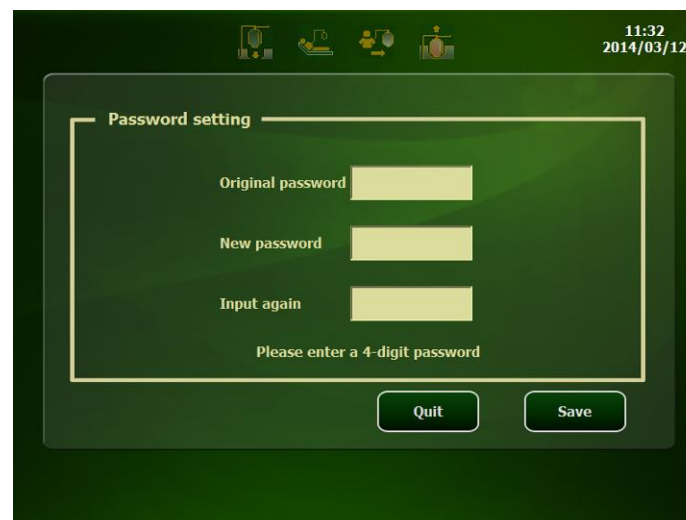

3.5.2.3 System Maintenance

This system is used only by a qualified engineer for product maintenance and repair. Press the **Configuration** at the interface of ready state and then input the maintenance password (12348888) to enter the maintenance interface:

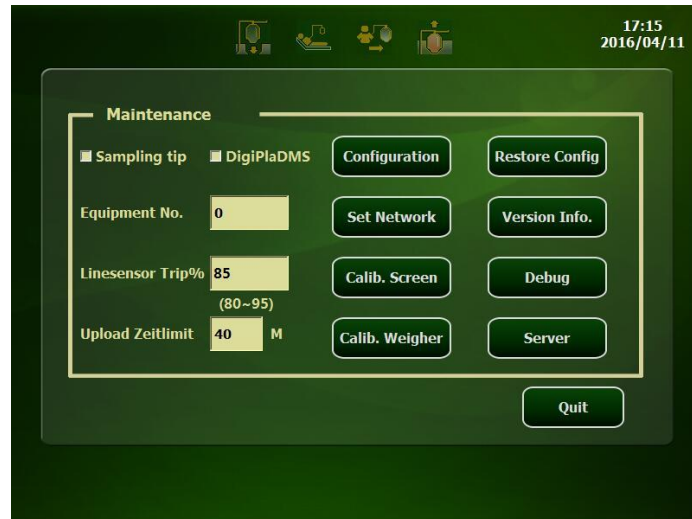

1. Line sensor Trip%

This item defines the sensitivity of a line sensor. it is used for monitoring the purity of the plasma, that's the blood cells mixed in the plasma, wherein the definable range is 80-95% and the factory default is 85%.

It is a threshold of plasma collection. The line sensor used to monitor fluid exiting the bowl through the effluent line during the Draw. A reference voltage be taken when plasma begin exit, it is 100%. If the voltage less the threshold which means blood cells mixing, the draw will automatically stop. Wherein the definable range is 80-95% and the factory default is 85%.

2. Configuration

The method of application is the same as that of System Configuration.

3. Network setting

The network can be set according to the local conditions.

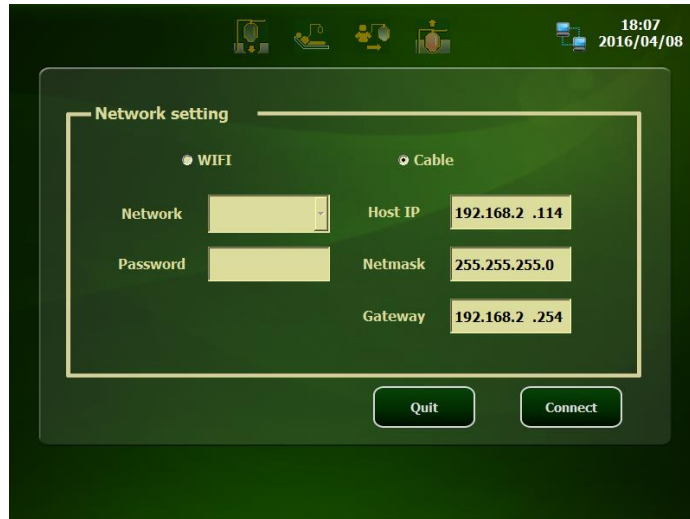

4. Touch screen calibration

In the condition that the click position on the display screen is imprecision, the touch screen calibration can be carried out according to processes as follows:

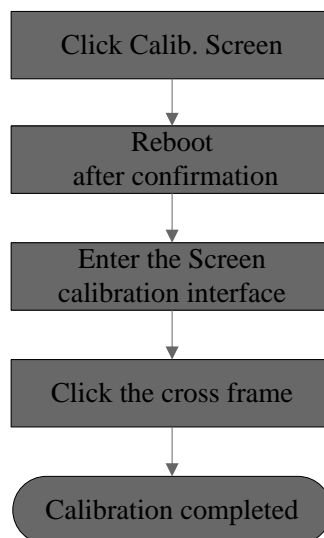

5. Plasma Weigher calibration

At the weigher calibrate interface, enter the Target Weight (200~1000g) and put weights on the chassis of the bag weigher or the tray of a bottle type weigher or hang weights on the bag weigher:

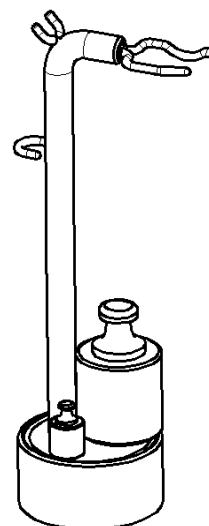
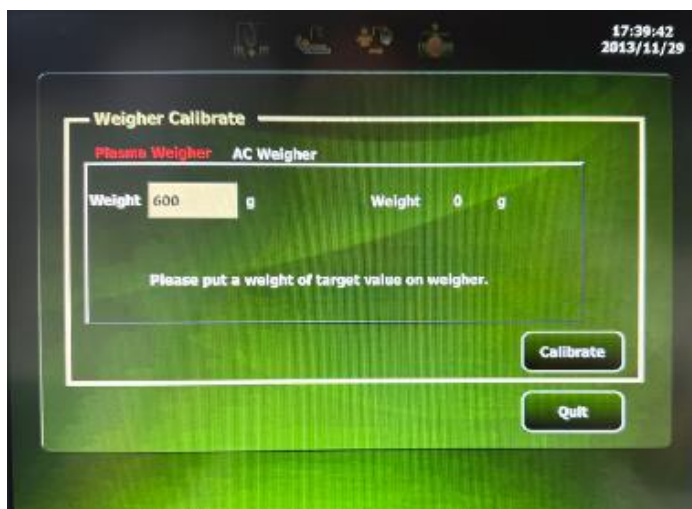

6. AC weigher calibration

The zero position must be corrected first, and then the standard weight must be hung for further calibration

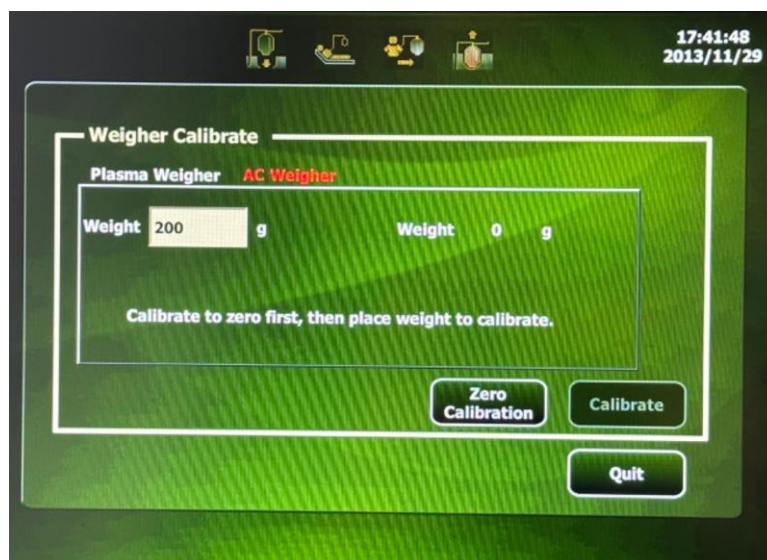

7. Restore factory settings

In restore factory settings, the following parameters will restore to the factory default: Equipment No., Unit, Set Params, Set Password, Set ID-input, DigiPlaDMS, Line sensor Trip% and Set Network.

8. Version information

The system version is the version of the software system while the components version is the version of the control software. The version information will be updated according to the software upgrade.

Caution: The system information must be confirmed before and after the software maintenance

9. Debug

Click the **Debug** button, the interface will load to the debugging interface, or, after the failure of start-up self-test, press the stop button twice to enter the debugging interface.

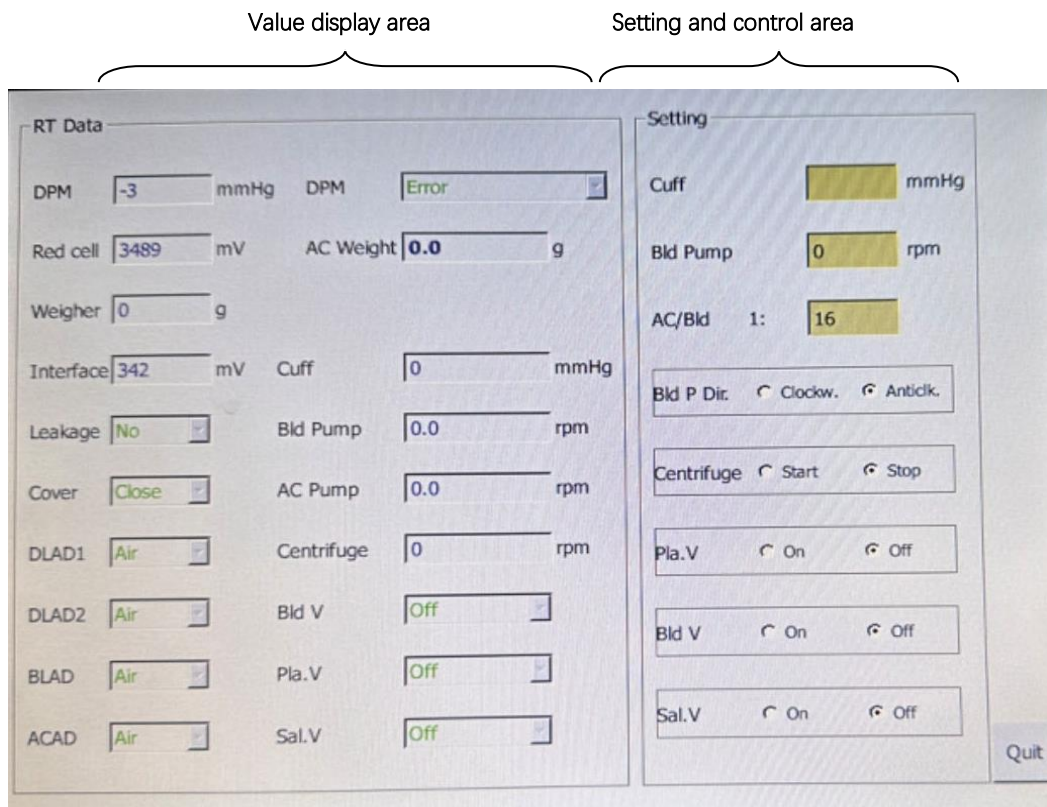

3.5.3 Function set

3.5.3.1 Management software preset

This item should be configured at the maintenance interface synchronously after mounting data management software on PC.

3.5.3.2 Network preset

The plasma separator support wired and wireless connection modes: for wired connection, connect the Ethernet port on the back of plasma separator with the corresponding port of the router through network cable (twisted-pair); for wireless connection, communication is carried out by the Wi-Fi module inside the plasma separator and the wireless router. The automatic management of collection results of the product is realized by the PC management software.

The network settings are as follows:

1. Click **Configuration** in the ready interface and input the maintenance password to enter the maintenance interface; then click **Network Setting** to enter the setting interface;
2. Only one of wired or wireless connection to a LAN can be chose at the same time;
3. For wireless connection, choose the router to be connected in the available wireless router list and input the correct connection password for connection;
4. There are for connection status as shown in follows:

1) Wired connection, connection succeeded. The corresponding icon is 

2) Wired connection, connection failed. The corresponding icon is 

3) Wireless connection, connection succeeded. The corresponding icon is 

4) Wireless connection, connection failed. The corresponding icon is 

4 **Function Inspection and Test**

4.1 **Preparation**

Inspection and test items of said part can be done by professional maintenance staff and users jointly.

4.2 **Equipment Status Inspection**

4.2.1 **Running status**

- After power on the plasma separator, the fan runs normally at once without making any abnormal noise. The system runs normally without any abnormal sound and condition.
- Enter the system maintenance interface to check the product settings, the optional fittings, the software version and other basic information of the system.
- Check the following items jointly with the user to confirm the system status:
 1. Any abnormal situation when the system is running.
 2. Occasional abnormal situations.
 3. Other items per requirements of the customer.

4.2.2 **Working Environment**

Check the runtime environment and the indoor temperature and humidity. The measurement associated with Safety features is very sensitive to moisture, the measuring position and the measurement circuit.

If insulation properties of a machine deteriorate as the increase of service life or faults of the machine, the fluctuation range of the measurement results may enlarge with the increase of humidity.

4.3 Regular Check

4.3.1 Check Procedure

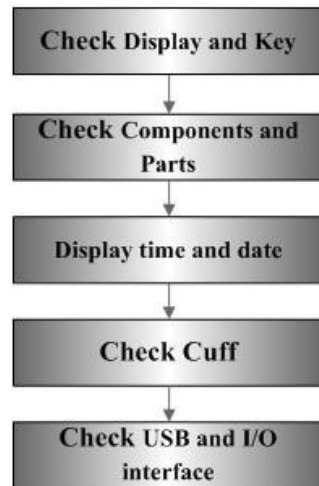

4.3.2 Inspection Contents

4.3.2.1 Display and Key

Steps	Standards
Display performance check	Pure color, clear and complete pictures, proper brightness, no-defocus and color missing, stable pictures.
The touch screen precision check	Press any keys, you can get the right correspondence as screen
The STOP key function check	To confirm the function, In the process of starting up self-test, load water pipe into any air detector; test will be failure, press STOP key and the device can enter the debug mode.

4.3.2.2 Assembly and Parts

Steps	Standards
Starting-up self-inspection test	Self-test is successful pass after power on,

4.3.2.3 Display time and date

Steps	Standards
At the Ready interface, check the time and date at the upper right corner of the display screen; or enter the configuration system and click Time Settings for checkup.	Confirm the displayed time and date is on local time. If they are not , adjust them.

4.3.2.4 Cuff Pressure

Steps	Standards
Inflate or deflate the cuff by pressing the 'CUFF' key	Inflation check, press CUFF key, the pressure of cuff goes up. Deflation check. Press CUFF key again, the pressure of cuff goes down.

4.3.2.5 USB and I/O interface

Steps	Standards
Barcode scanner and USB interfaces: After the barcode scanner is normally connected to the USB interface, check its status at ID entering interface.	The scanned information can normally display on the screen ID window.
Ethernet port: Check wire and wireless networks	Use network ping method to check data transferring, no errors to be found.

4.4 Function Inspection

Caution: This part lists the inspection items of a system with complete optional functions and gives detailed description to the key items, however, if a function is not selected, the corresponding inspection items can be ignored.

4.4.1 Inspection Procedures

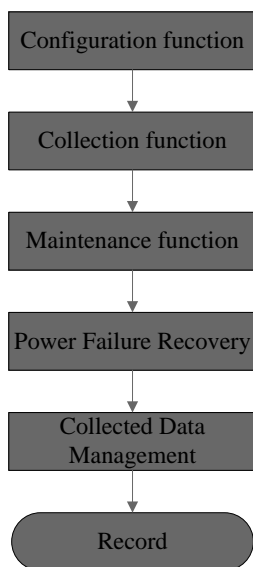









4.4.2 Inspection Contents

4.4.2.1 Device Configuration

Enter the configuration interface, revise or set the language, unit, set parameters, set personal password and the set ID-input and other items used in collection per custom requirements.

4.4.2.2 Collection function check

At the collection mode, complete the disposable installation according to the interface prompt, use water as the collection simulation, and inspect the following items after entering the collection interface:

Inspection Content	Inspection Standards
Pump speed adjustment	At the collection or return interface, click the setting button of blood pump On  /Off  , and add  /reduce  buttons to regulate the pump (adjust the step value to 5).
Cuff pressure adjustment	At the vein-puncture or collection interface, click the cuff On  /Off  , and add  /reduce  buttons to adjust the cuff (adjust the step value to 5).

ID modification	At the collection or return interface, click the ID button. Enter the ID modification interface, display the inputted ID, click the edit box to pop-up a keyboard, use the keyboard to input legal characters, and click Enter on the keyboard to complete the input.
Parameter modification	At the collection or return interface, click the Setting button. Enter the parameter modification interface, display the configured parameters, click the edit box to pop-up a keyboard, use the keyboard to input legal characters, and click Enter on the keyboard to complete the input.
Check the collection result	After the plasma separator completes the total preset collection, it will make a noise prompt and display the collection result report on the screen.

4.4.2.3 Others

Enter the maintenance interface to configure the DigiPlaDMS, modify parameters of the Line sensor Trip% and other items and check the version information, see 3.5.2.3 for the inspection method.

4.4.2.4 Power Failure Recovery

If there is a power failure in the plasma collection process, the operating interface will provide three options (**Draw/Return/Exit**) after recover the power supply and restart the equipment. The plasma separator can automatically memorize the operating status and operating parameters, click the button of relevant procedure to continue to the next step; or click **Exit** to enter the summary of collection results.

4.4.2.5 Collected Data Management

After completing a collection process via test materials and confirming a report of the collection result, the corresponding result can be checked on a PC equipped with data management software.

4.5 Performance Test

This test should be performed at the debugging interface under the collection status:

Inspection Content	Inspection Standards
Valve block	Hang a plasma bag full of water upside down on the bracket of anticoagulants, enclose the outlet line into a valve, enter the debugging interface to set the status of the valve, and each valve in the closed state shall ensure that the water in the plasma bag does not leak.
Weigher	In the maintenance mode, click on the Calib. Weigher button to enter

	the calibration interface, wait till the reset of an electronic scale, put weights of 200g, 600g, 1000g respectively, and the difference between the value displayed on the screen and the actual weight is less than or equal to 5g.
Centrifuge-bowl leakage alarm	In the collection process, press the stop button when the machine runs normally to suspend the operation of the centrifuge, open the centrifuge cap, use cotton swab to dip in a good amount of clean water, apply the water on a leakage detector of the centrifuge, the system gives sound and light alarm and makes prompts on the screen.
Air alarm	In the collection or return process, take out the pipeline from the air detector, the system gives sound and light alarm and makes prompts on the screen
Pressure alarm	<p>Low pressure: in the process of collection, Clamp the blood inlet pipeline of the blood member with haemostatic forceps, the DPM on the interface falls gradually, the color will change from blue to red until disappear; the system gives sound and light alarm and makes prompts on the screen.</p> <p>High pressure: in the process of return, clamp the blood inlet pipeline at the air detector of the blood member with haemostatic forceps, the Donor Pressure Monitor (DPM) on the interface rise gradually to the top, the system gives sound and light alarm and makes prompts on the screen</p>

5 Software Upgrade

5.1 System Software

Caution: The version information of the system software after upgrading can be checked at the interface of ready state or the maintenance interface.

5.1.1 Upgrade Necessary

1. Format software which has FAT32 function
2. A TF card
3. A PC (personal computer).
4. Update files.

5.1.2 Pre-upgrade Installation

1. Preparation of TF card, format it to FAT32 as below

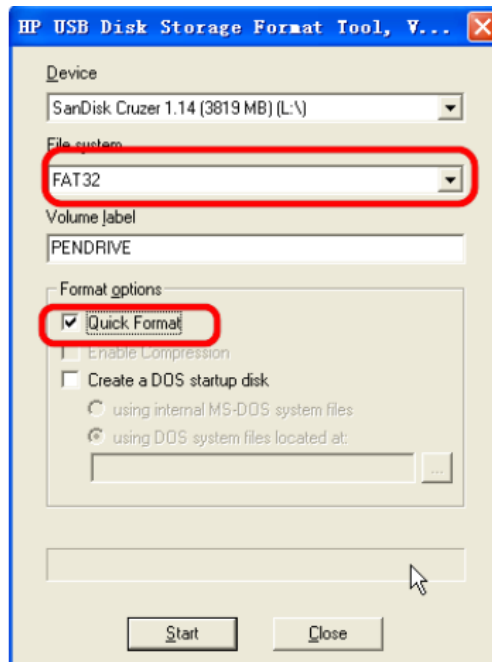

2. Copy the upper computer update files to TF card.

5.1.3 Programming Software

1. Turn off the power. Put the 3 and 4 on the dial to the OFF state, then 1 and 2 to the ON state.

Insert the TF card



Turn on, the update process will automatically run until the picture appear.

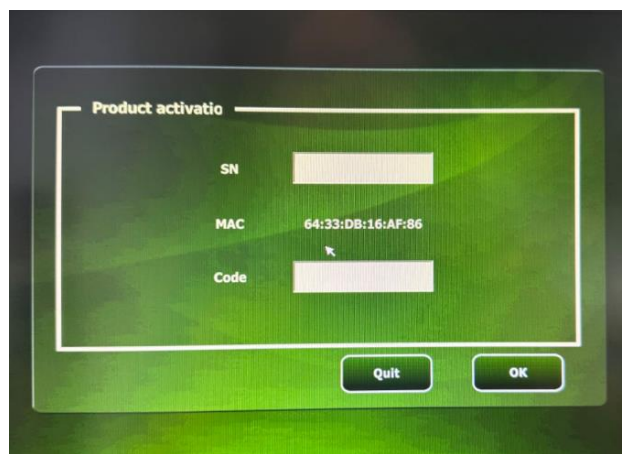

Turn off the power. Put the 3 and 4 on the dial to the ON state, then 1 and 2 to the OFF state. This step is also very important; Otherwise the system program cannot start, as shown in the following figure.



2. Take out the TF card .
3. Reboot the Plasma Separator, and then report the MAC to Nigale to get the activation code.
4. Input the Code to activate the machine.

5.2 Control Software

- Caution:**
1. Operators should wear electrostatic rings in the process of programming.
 2. To avoid oxidation, the all pin of the adapter are dry and clean
 3. The version information can be found on Configuration menu.

Upgrade Equipment

1. Programming unit one:
MPLAB PM3, Adapter: AC164323
2. Programming unit two:
KIT3.5 can be used.

** Both units can be used.

1. Pre-upgrade Installation (PM3) Install the adapter (AC164323) on a socket module connector on a programming unit (MPLAB PM3) . Align the connector on the socket module at the connector on the MPLAB PM3, and downward push the socket module with constant speed to make it closely matching with the connector;
2. Align the SD card stored an appropriate version of object code software (HEX file) at the SD card slot at the back of the MPLAB PM3 programming unit, and insert the notch end of the card into the slot. The card is locked and can only be inserted along one direction. Push the card into the slot (push the SD card inwardly at first to release it before pulling it out).

5.2.1 Programming Software

1. Power on the programming unit (MPLAB PM3) .
2. Select option Select Device on the main menu to specify the series of the device and then select the device to be programmed.
3. Select option Program/Verify Device, and then program the device in the socket module and verify it.
4. The software upgrade is completed.
5. Kit3.5 below.



5-4 Software Upgrade

6 Hardware System

6.1 System Composition

The hardware system of the separator plasma adopts the hardware structure of an upper computer and a lower computer composed by two CPUs.

The upper computer is provided with an embedded operating system, it is concentrated on the human-computer interaction, data management and other user applications, and it support and extend the input/output peripherals, such as the Ethernet interface, the USB interface, the audio interface, etc. The lower computer is concentrated on applications control, comprising the operations of various peripherals (pump, valve, centrifuges, etc.), and the monitoring and alarm to various signals (the open/close valve and the sensor signals transfer).

The communication between the upper computer and the lower computer is achieved by the serial port, wherein the upper computer directs the operating status of the lower computer through different commands while the lower computer gives feedback about the corresponding executing state and results.

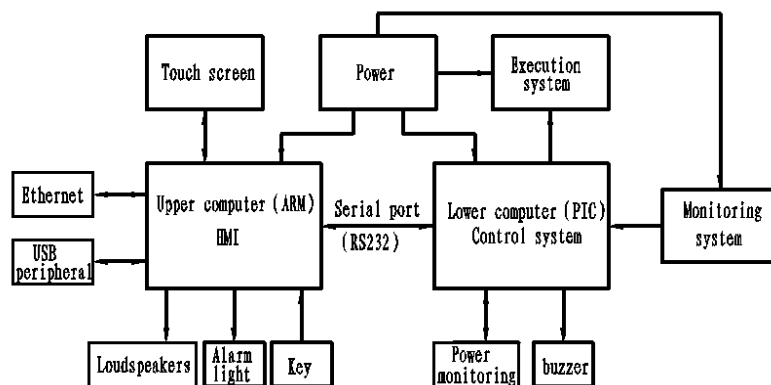

Figure 6-1 Block Diagram of the Hardware System Structure

Figure 6-1 is the structure diagram of the hardware system, which gives commands to various components. According to structure , the plasma separator is divided into 3 major components: the human-computer interaction system (the human machine interface and data management), the collection system (to complete the collection function) and the power supply system (provide power support to the whole machine), wherein the collection system is composed of a control system (the collection process control), an execution system (actuated) and a monitoring system (sensing signal collection).

6.1.1 Human-computer Interaction System

The human-computer interaction system (upper computer) is focused on human-computer interaction HMI (Human Machine Interface) and faces the operator directly, it is an interface for mutual communication and conveying and receiving information between the operator and the plasma separator. The user controls and participates in the plasma collection process through the human-computer interaction system. The system equipped microprocessor ARM Cortex-A8 and a peripheral circuit as the core to configure peripheral interfaces that are necessary for certain functions.

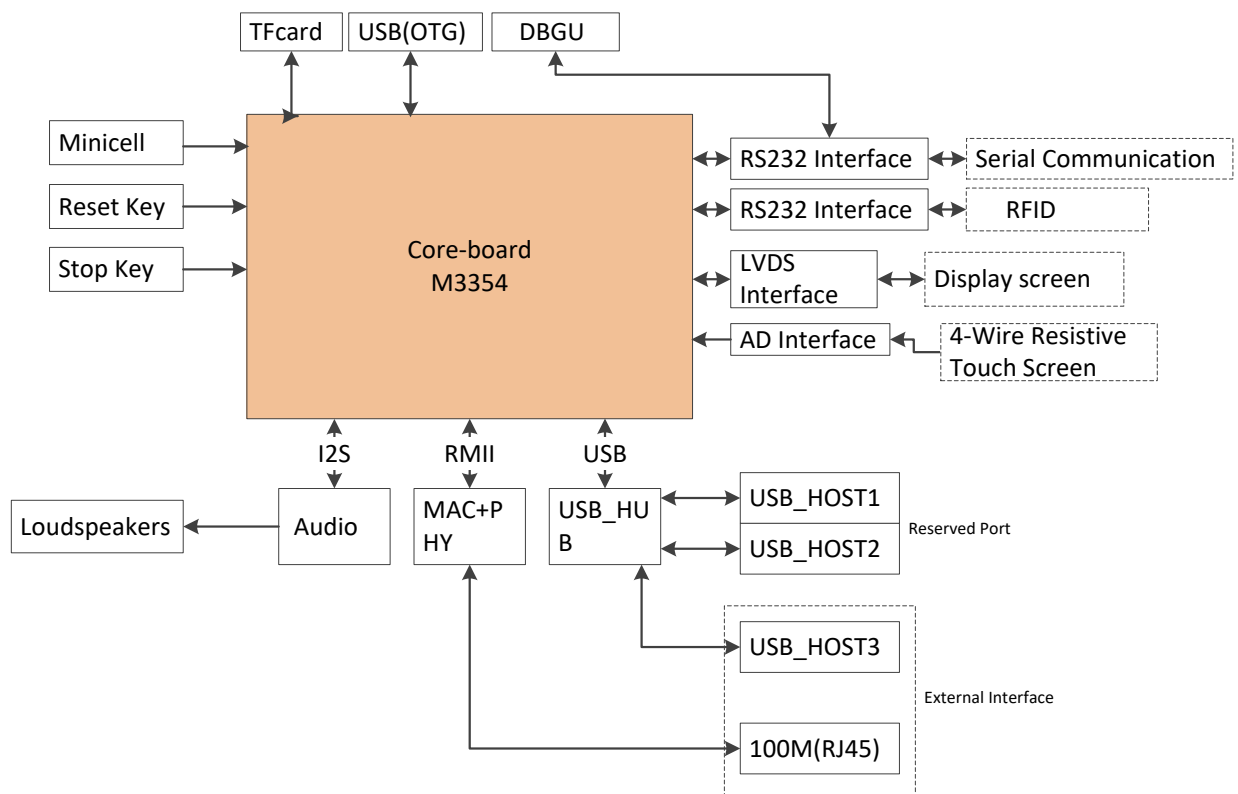

Figure6-2 Block Diagram of the Human-computer Interaction System

6.1.2 Collection System

The Collection system is composed of a control system, an execution system and a monitoring system, and the function thereof is to complete the plasma collection. The Control system is composed of a PIC32 micro controller and related peripheral interface circuits, and it is responsible for controlling the whole plasma collection process; the execution system comprises a centrifuge, a peristaltic pump, pump drivers and pressure measurement and monitoring the air in the system; the monitoring system completes the measuring of all relative physical quantities in the collection process by an analog quantity or switching valve interface circuit via multiple different kinds of sensors. At the same time, the collection system receives the upper computer instructions and upload data via serial communication.

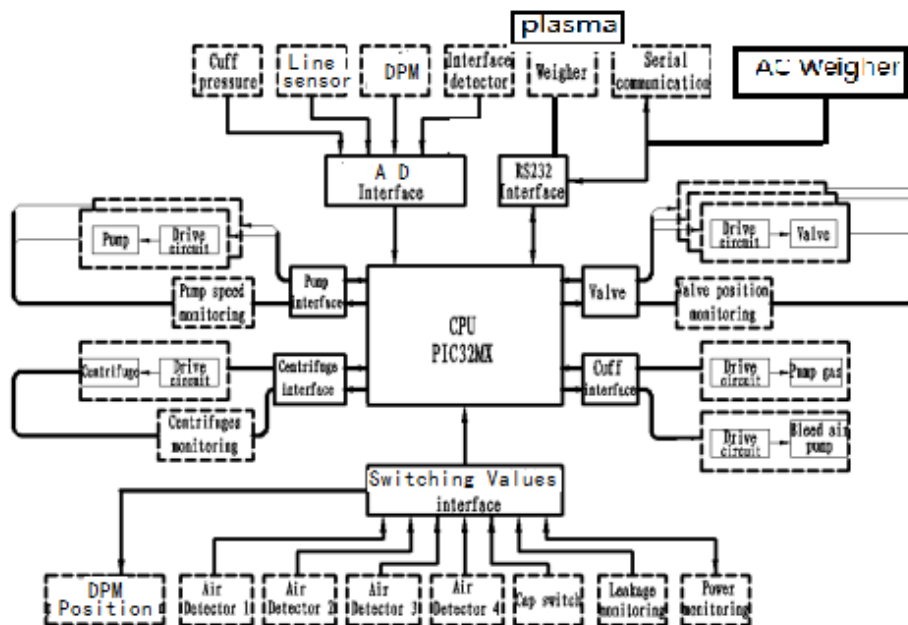

Figure6-3 Block Diagram of Collection System

6.1.3 Power System

The power system is divided into two independent ways. One way is via an isolating transformer to provide a centrifuge AC driver with power; the other power supply is via the switching power supply(AC/DC) and then different DC/DC voltages are generated through various DC switching circuits

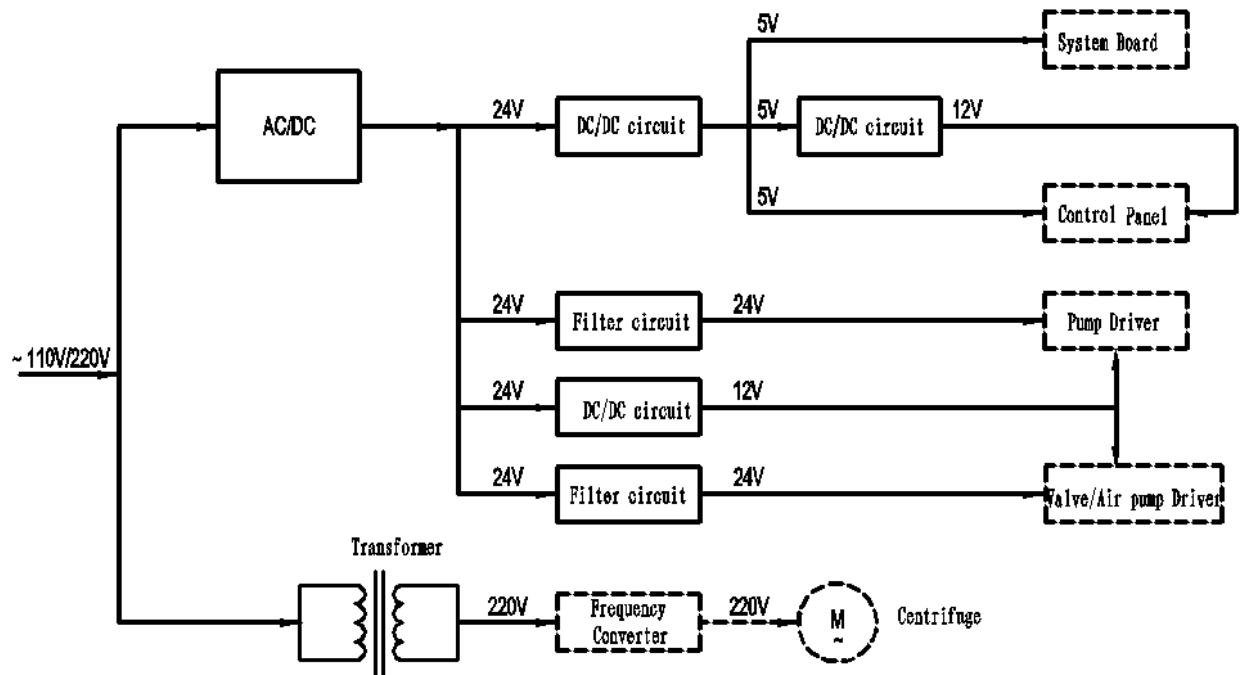

Figure6-4 Block Diagram of Power Supply System

6.2 Function Board Card Introduction

A control board and a driver board achieve signal transmission via a backplane, and the main monitoring components are connected to the control board via a connector on the backplane while all execution units are connected via driver board. The power supply assembly, the control board, the driver board and the backplane are arranged in a case, a communication board is mounted on the back shroud of the case and a system board is installed in the display. The communication signal wires of the system board and the control board are switched over through the communication board. Figure 6-5 Schematic Diagram of Board Card Connection.

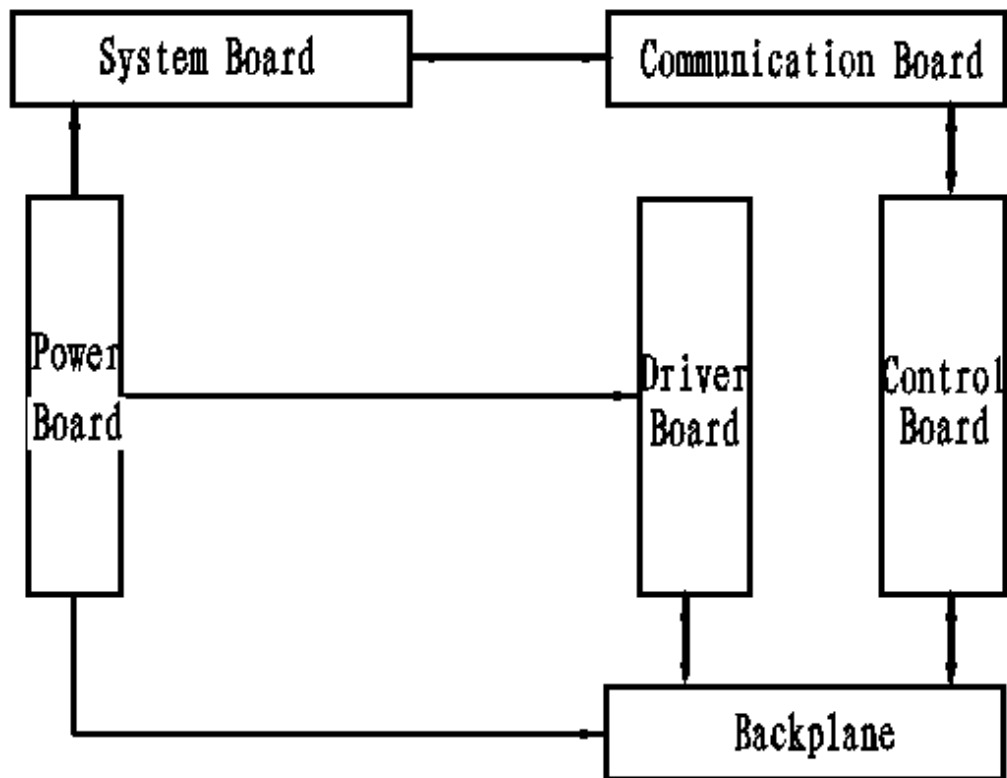

Figure 6-5 Schematic Diagram of Board Card Connection

6.2.1 System Board

As the main part of the display of a plasma separator, the main function of the system board is the human-computer interaction (HMI) application and to complete the hardware platform required by the human-computer interaction. The functions thereof are achieving the communication between it and the lower computer, real-time displaying the acquired information, completing the input and display of the interactive information, and generating corresponding alarm information. It can be divided into a core-board module, a power supply module, an alarm module, a TF card module, a WIFI module, an alarm sound module, a display module, a touch screen module and a lower computer module according to functions.

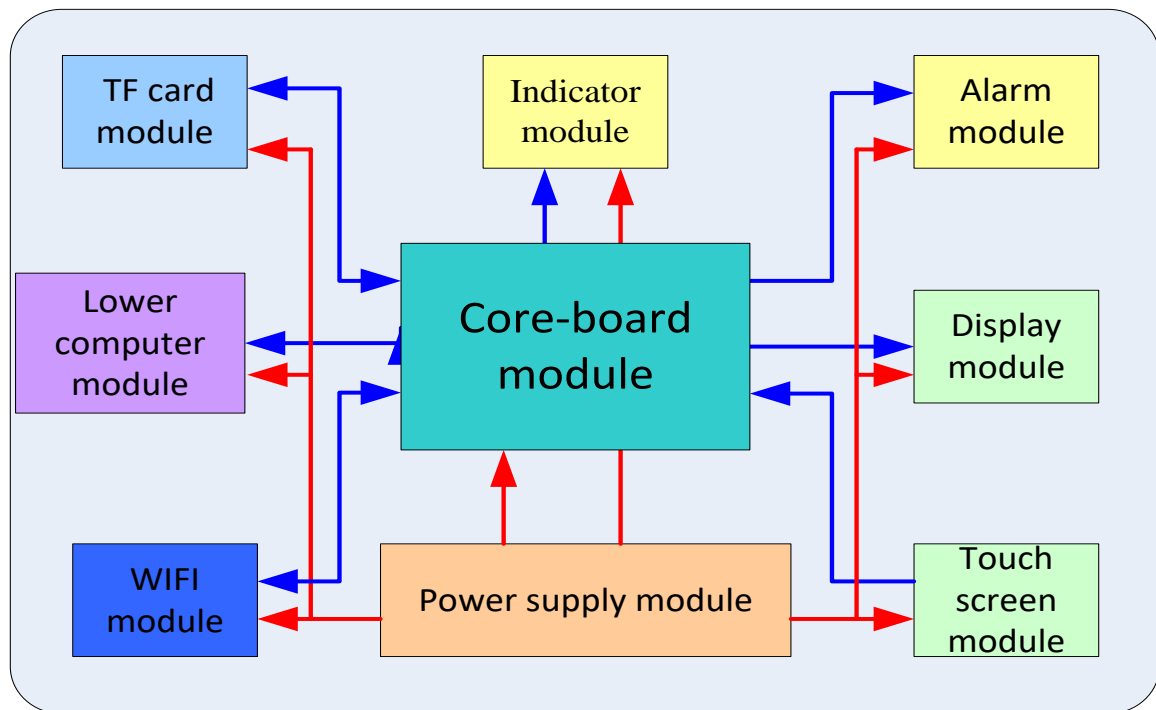

Figure6-6 Logic Block Diagram of System Board

6.2.2 Control Board, Driver Board and Backplane

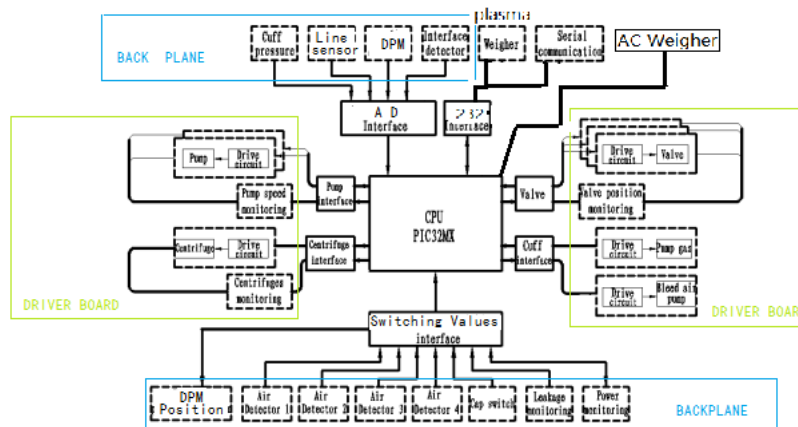

Figure6-7 Logic Block Diagram of Control board, Driver board and Backplane

6.2.2.1 Control Board

The control board is a hardware platform used for controlling and monitoring the collection process. The functions thereof comprise achieving the communication between it and the upper machine, receiving control commands from the upper computer and making correct response, real-time controlling various peripherals and real-time monitoring various sensing signals in the collection process, and sending the acquired information up to the upper computer.

Function paths:

- A low-pass filter is composed of an operational amplifier and the analog quantity interface is completed by a 5V-3.3V level translator;
- The level switch of the serial port communication is achieved through a serial port conversion chip MAX3232;
- Valves open or close, pumps running or stop are controlled by the signals from the I/O port directly, and the control section and the drive section are isolated by optical couplers, wherein the pump speed control and feedback should be completed by high-speed optical coupler;
- Cuff inflation or deflation, centrifuge running or stops are controlled by the signals from the I/O port directly, and the control section and the drive section are isolated by optical coupler.
- The data storage of the control board consists of EEPROM, and the master controller is communicated with EEPROM using the SPI communication protocol;
- The isolation and logic level switch of the outward RS485 communication of the control board is achieved by chip ADM2587, exchange data with AC weigher.

6.2.2.2 Driver board

The driver board is a hardware board card used for driving main collection functional units of the plasma separator and giving signal feedback, the control signal input and feedback signal output thereof are both pointed to the control board. The functions thereof comprise achieving the electric drive and position signal feedback of the electromagnetic valve, the electric drive and speed & directional signal feedback of the peristaltic pump, the start-stop control and the speed signal feedback of the centrifuge machine, the drive force to the air pump and vent valve of the cuff, and it also provides a cuff pressure sensor signal collection channel.

Function paths:

- The standard 5.0V power supply of the cuff pressure sensor is provided by chip TL431;
- The solenoid valve is drove by chip DRV103H0, the sustaining voltage of the solenoid valve is controlled by the PWM output DRV103H0 and can be adjusted by changing divider resistances;
- The position monitoring of the solenoid valve is achieved by the optical coupler on the triode BC846B driver control board;
- LM7805 provides +5V power supply for the logic control of the pump;
- The direction monitoring of the pump is achieved by a phase discriminator composed of CD4011 and CD4044 by outputting signals to group A and group B motor encoders, and the results are feedback to the control board in the manner of high and low levels;
- LM7805 provides a +5V power supply to the release valve of the cuff.

6.2.2.3 Backplane

The main function of the backplane is to serve as a signal connection channel between the control board and the driver board, wherein the channel is achieved by the board to board connectors on three board cards, at the same time, it is also the input channel of the multi-channel analog and the switching value and, the power input channel of the control board.

The relationships among the backplane, the control board and the driver board:

- All the analog input channels of the control board are connected with the exterior through the backplane, comprising the electronic scale, the pipeline pressure, the cuff pressure and the line sensor output;

- All the switching value input channels of the control board are connected with the exterior through the backplane, comprising the cap switch status, and the connector status of the leakage sensor and the pipeline pressure detector;
- The solenoid valve, the blood pump, the anticoagulant pump and the cuff control channel of the driver board are all connected with the control board through the backplane.

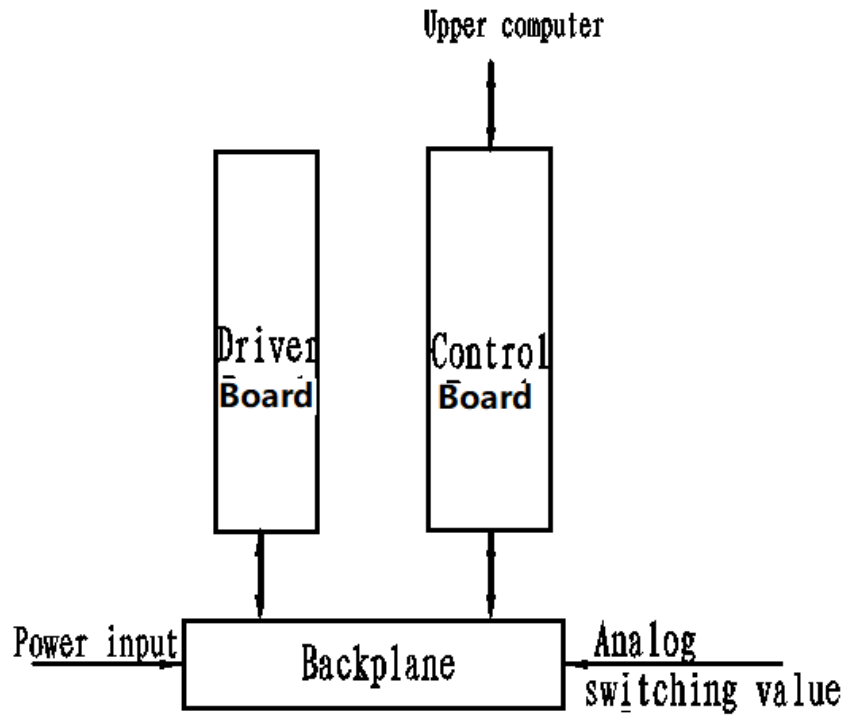

Figure 6-8 Block Diagram of the Connection Relationship of the Backplane, the Control board and the Driver Board

6.2.3 DC Power Board

The DC Power Board is consisted of a 24V/5V (DC/DC) power module, 24V/12V (DC/DC) switching circuit and a 5V/12V (DC/DC) switching circuit.

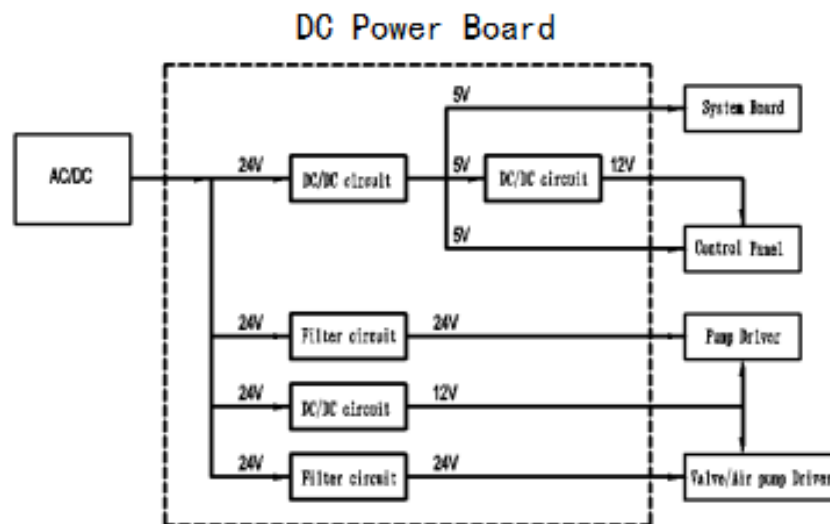

Figure 6-8 Logic Block Diagram of DC Power Board

6.2.3.1 24V/5V (DC/DC) Power Module

Power module model: WD25-24S05D1. The module completes the transformation from DC 24V to DC 5V, and the control parts (the upper computer and the lower computer) of the whole hardware system are both provided by the 5V. The leading indicators are as follows:

- 1) Input voltage range: DC18V~DC24V;
- 2) Output voltage accuracy: $5V \pm 1\%$;
- 3) Transfer efficiency: typical value 85%;
- 4) Over current and short circuit protection, and automatic recovery function;
- 5) Switch frequency: 300KHz.

The maximum rated output current of the module is 5.0 A while the maximum load demand is rated maximum current 3.0 A.

6.2.3.2 24V/12V (DC/DC) Switching Circuit

The control circuit part of the peristaltic pump needs a 12V DC power, wherein said part is composed of an integrated circuit LM2575 and some peripheral devices.

6.2.3.3 5V/12V (DC/DC) Switching Circuit

Since the control part has only a group of separate isolated 5V power supply, a 12V power supply should be provided to the sensor on basis of a DC/DC booster circuit of the 5V power supply. The input voltage range of the chip is 2.7V to 14V, the maximum output voltage can be adjusted to 20V, and the maximum load capacity is 1.4A.

6.3 Structure Dismounting



This part mainly focuses on the dismounting processes of main components and hardware board cards, and the assembly should be done according to the inverse process of disassembly if there is no special instruction.

6.3.1 Dismounting Tools

An internal hexagonal wrench (M4、M5) , a cross screwdriver (0#、2#) , a straight screwdriver (the tool bit is 3mm wide), a pair of antistatic gloves and a sleeve (M3、M4) :



6.3.2 Marking Instruction

-  —removed parts (screw for example)
-  —refers to the disassembled part (such as the cable plug, etc.)
-  —installed parts

6.3.3 Personnel requirements

The dismantling work must be done by maintenance engineers of Nigale who have professional knowledge or skills or engineers obtaining the skills by training.

6.3.4 Preparation for Dismounting

Please make following preparations before dismantling the plasma separator:

1. Stop the plasma separator, shutdown, disconnect the AC power supply, and unplug the AC power cord;
2. Remove the peripheral barcode scanner and other products;
3. Ready the disassembling tools and the anti-static gloves.

6.3.5 Dismounting of Host Assembly

6.3.5.1 Front Cover of Host

1. Take down 2 screws (M4×8) from the lower front end of the host;



Figure 6-3 Diagram for Dismounting of Front Cover of Host

2. Apply a gentle force to the front direction of the device to pull out the front cover of the host

6.3.5.2 Rear Cover of Host

Lift up the brine strut and the anticoagulant strut, and remove the combination screw fixed on the frame from the rear cover of the host. Pull outwardly from the bottom of the equipment to remove the rear cover of the host.



Figure 6-4 Diagram for Dismounting of Rear Cover of Host

6.3.5.3 Left and Right Cover Assemblies of Host

1. Remove the sunk screws (M4×8, two for each side) fixed on the left cover and the right cover;



Figure 6-5 Diagram for Dismounting of Left cover and Right cover of the Host

2. Pull the side cover rearward to remove the corresponding left and right cover assemblies of the host

6.3.5.4 Display Assembly

1. Remove the display assembly from the host, see 3.3.3 for the process (use the inverse process);
2. Remove four screws (M3×8) fixed on the rear cover of the display;



Figure 6-6 Diagram for Dismounting of Rear Cover of Display

3. Remove 4 M4 screws between the upper end of the support arm and the fixed board of the display, and take down the support arm; ;
4. Disconnect the cable connector on the system board, at the same time, and remove the four screws (M3×8) on the fixed cover of the display to take down the fixed cover of the display.

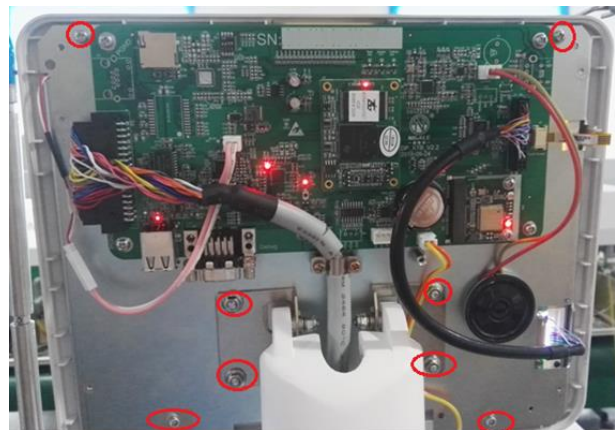

Figure 6-7 Diagram for Dismounting of Support Arm and Fixed Cover

6.3.6 Board Card Dismounting

The control board, the driver board and the backplane of the plasma separator are mounted in the plug box of the host case:

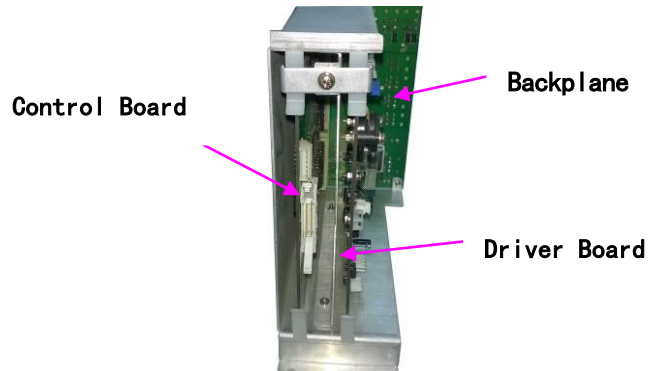
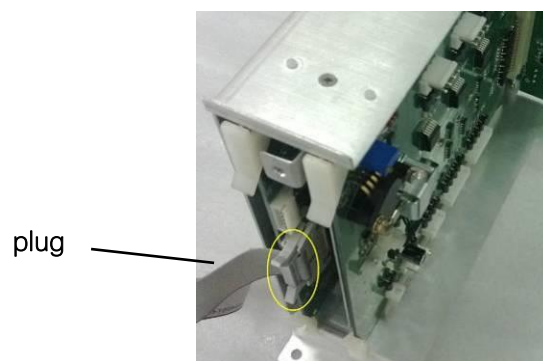

Figure 6- Structure Chart of Board Card Position of Board Cage

6.3.6.1 Control Board

1. Dismounting the rear cover of the host;
2. Dismounting the screws(M4×8) on the plug box and take down the plug box pressing board;
3. Disconnect the communication cable on the control board, flip the plug device on the board card to separate the socket of the control board from the socket on the plug box, and pull vertically to the external side of the case to take down the control board.
- 4.



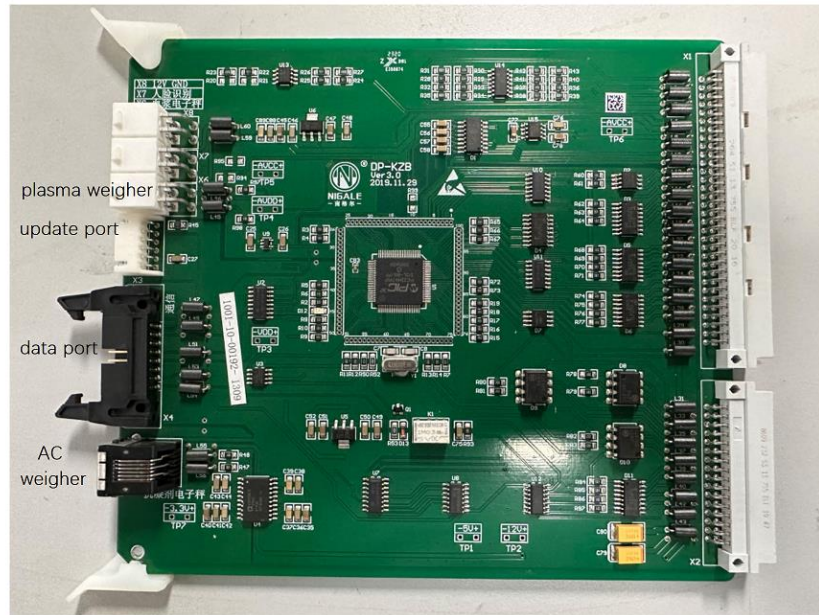

Figure 6-9 Diagram for Dismounting of control board

6.3.6.2 Driver Board

1. Dismounting the pressing boards on the rear cover of the host and the plug box (the same as 7.2.5.1);
2. Remove the connection cable on the driver board, flip the plug device on the driver board to separate the socket of the driver board from the socket on the plug box, and pull vertically to the external side of the case to take down the driver board.

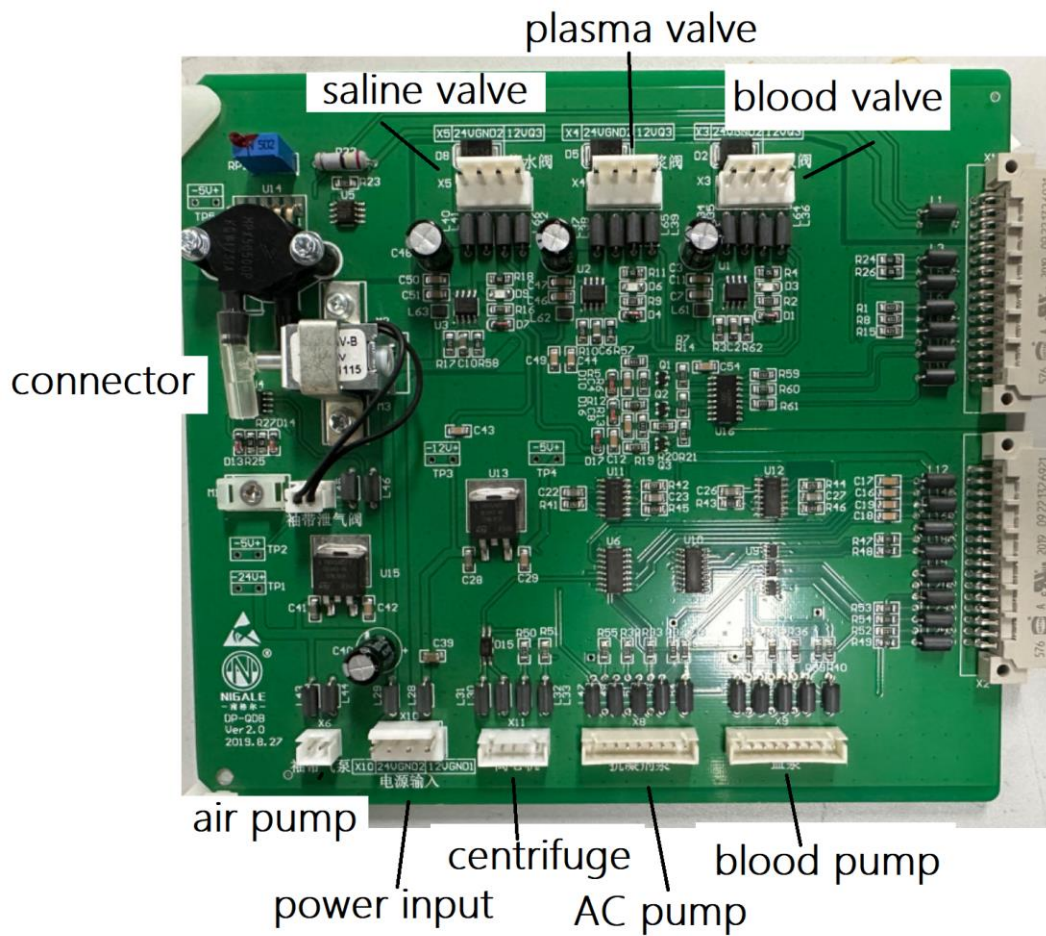

Figure 6-1 Diagram for Dismounting of Driver Board

6.3.6.3 Backplane

1. Dismounting the rear cover and right cover assemblies of the host;
2. Pull up plugs connected on the backplane;
3. Remove 6 screws (M3×10) from the backplane to take down the backplane.

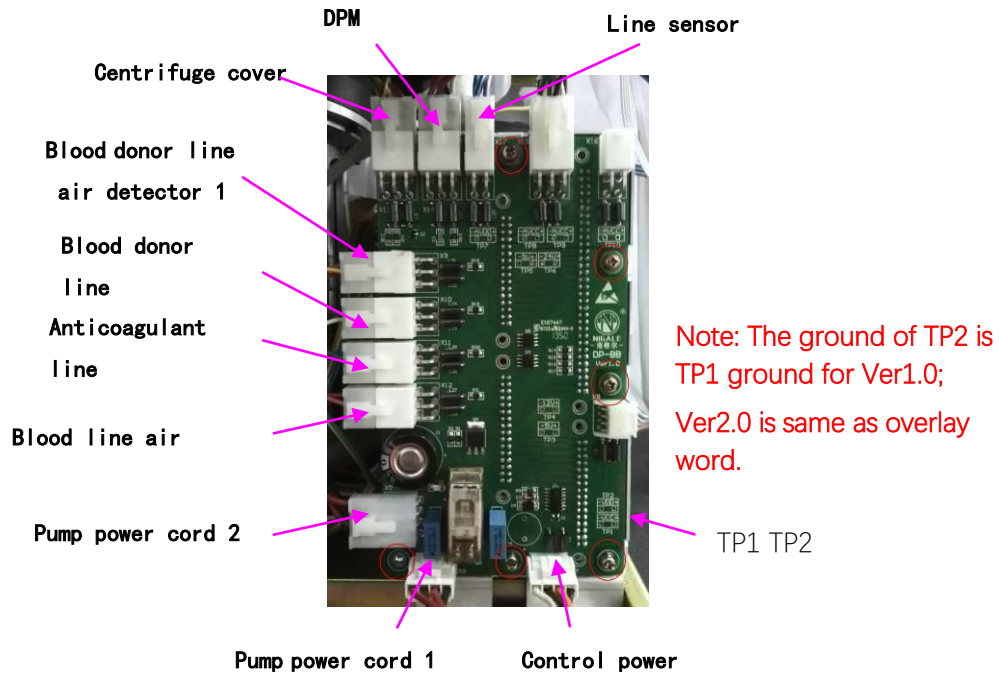

Figure 6-11 Diagram for Dismounting of Backplane

6.3.6.4 System Board

1. Remove the rear cover of the display (the same as 7.2.4.4) ;
2. Disconnect cables connected on the system board and remove 4 combination screws (M3×8) from the system board to take down the system board.

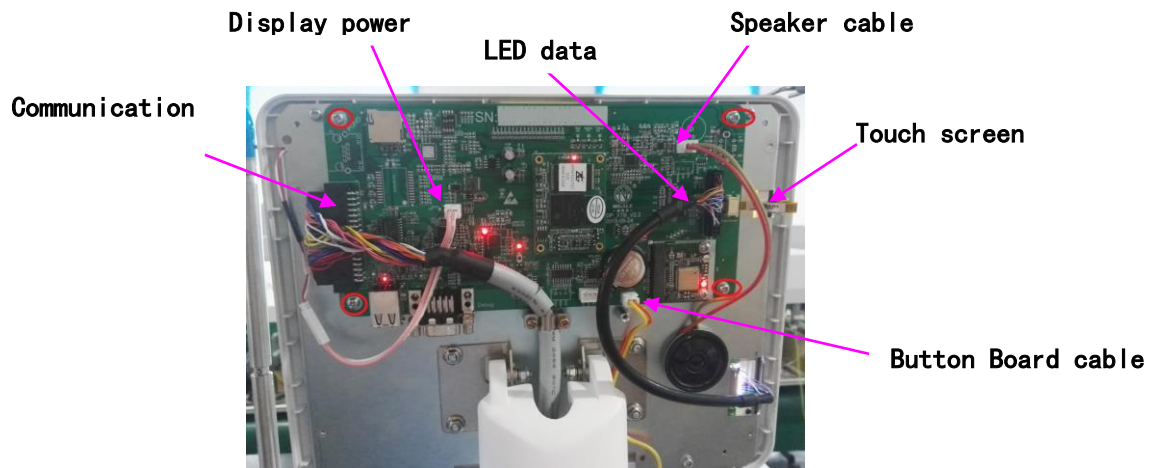

Figure 6-12 Diagram for Dismounting of System Board

6.3.6.5 Communication Board

1. Dismounting the pressing boards on the back cover;
2. Pull out plug on the communication board;
3. Remove 4 screws (M3×10) from the communication board to take down the communication board.

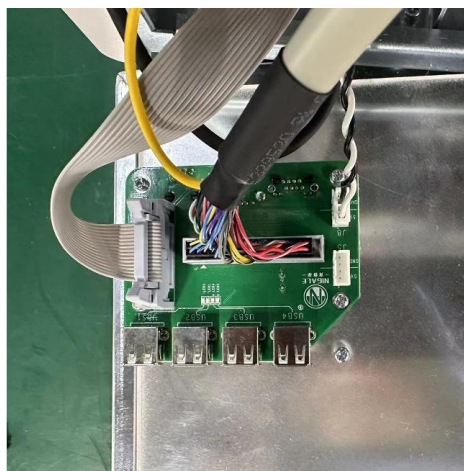

Figure 6-13 Diagram for Dismounting of Communication Board

6.3.7 Dismounting of the other parts

6.3.7.1 Air Detector

1. The plasma separator contains 4 air detector with the same structures and performances: anticoagulant line air detector, Blood donor line air detector 1, Blood donor line air detector 2 and blood line air detector.
2. Dismounting the pressing boards on the rear cover and left side cover of the host
3. Pull up the corresponding cables from the backplane;
4. Remove the two screws (M3×8) at the bottom of the air detector on a horizontal operation panel (an anticoagulant air detector) or a bevel operation panel (blood member pipeline air detector 1, blood member pipeline air detector 2, and a blood pipeline air detector), and take down the corresponding air detector from the operation panel.



Figure 6-14 Diagram for Dismounting of Air Detector Modules

6.3.7.2 Valve

1. The plasma separator comprises three solenoid valves (Plasma valve, Saline valve and Blood valve) having the same structures and performances;
2. Dismounting the front cover (blood valve) and rear cover (plasma valve and saline valve) assemblies of the host;
3. Remove the screws(M4×8) connecting the grounding wire of the solenoid valve and the host frame, unplug the connecting plug of the corresponding solenoid valve on the driver board;

4. Remove the nut at the bottom of the solenoid valve, pull it down and take down the corresponding solenoid valve from the operation panel.



Figure 6-15 Diagram for Dismounting of Valve

6.3.7.3 Centrifuge Assembly

1. Dismounting the front cover and rear cover assemblies of the host;
2. Remove the three motor wires on the of the centrifuge driver and the two screws(M4×20) on the opposite angle thereof, and remove them out from the host;



Figure 6-16 Diagram for Dismounting of Centrifuge Assembly I

3. Remove the centrifuge wires on the driver board and the backplane respectively, dismount the screws connected with the grounding wire of the centrifuge and the four hexagon socket cap screws(M5×16) at the bottom of the centrifuge;

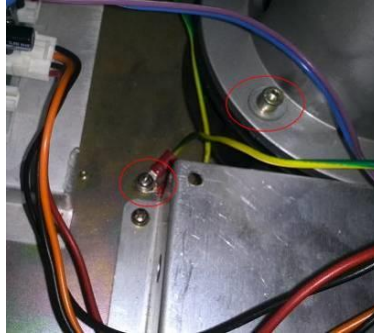

Figure 6-17 Diagram for Dismounting of Centrifuge Assembly II

4. Take out the centrifuge from the top of the horizontal operation panel.



Figure 6-18 Diagram for Dismounting of Centrifuge Assembly III

6.3.7.4 DPM (Donor Pressure Monitor)

1. Dismounting the front Cover;
2. Pull up the wire connected to the backplane, remove the fixed screws (two M3×8 screws) connecting the pressure monitor assembly with the bevel operation panel, drag out the assembly from the back side of the operation panel.



Figure 6-19 Diagram for Dismounting of DPM

6.3.7.5 Pump Assembly

1. The plasma separator comprises two pump assemblies: Blood pump and Anticoagulant pump;
2. Dismounting the front cover assembly, left cover(Anticoagulant pump) and right cover (blood pump) of the host;
3. Remove the socket head cap screw(M5×16) on the pump head, pull outward to take out the pump head;



Figure 6-20 Diagram for Dismounting of Pump Assembly I

4. Pull out three plugs connected with the pump from the digital AC serve drivers in from of the host frame and the cable connected with the driver board;

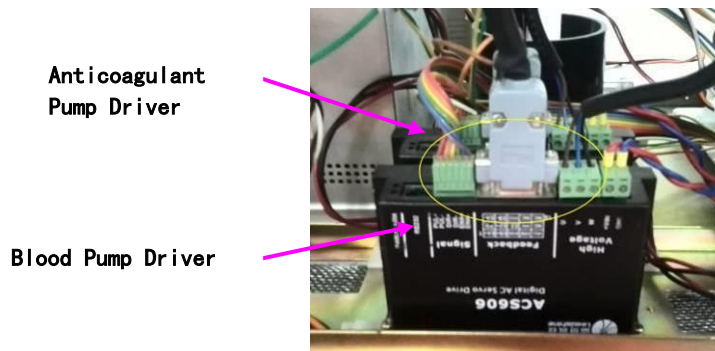

Tips: Anticoagulant Pump Driver and Blood Pump Driver are completely consistent in hardware but different in software . Be attention do not confuse them.

Figure 6-21 Diagram for Dismounting of Pump Assembly II

5. Pull hardly and press the spindle of the serve motor at the back of the bevel operation panel to take down the motor of the pump.



Figure 6-22 Diagram for Dismounting of Pump Assembly III

6.3.7.6 Weigher

1. Remove the weigher on the rear cover of the host, the left side board assembly and the horizontal operation panel;
2. Remove the screws(M4×16) connected with the nut stud of the host frame;
3. Drag out the weigher outwardly in level.

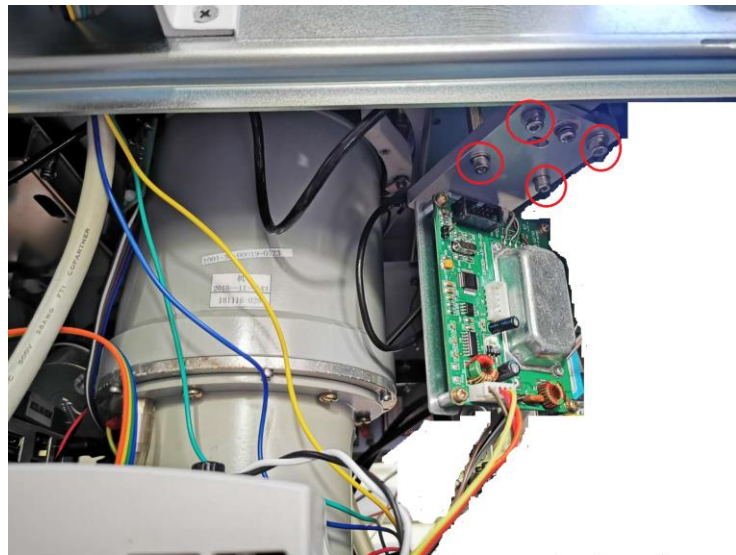
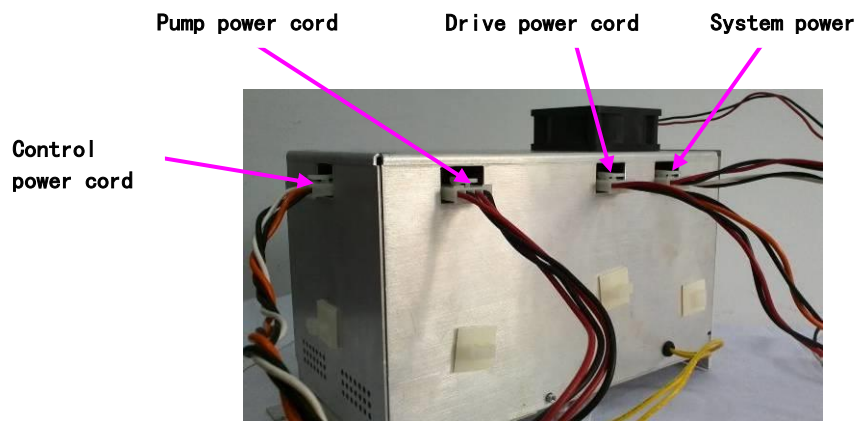

Figure 6-23 Diagram for Dismounting of Weigher

6.3.7.7 Power Supply Assembly

1. Dismounting the rear cover and right side cover of the host;
2. Remove the cables connected with the power pack assembly



**Figure 6-24 Diagram for Dismounting of Power
Power Supply Assembly**

3. Remove two screws on the power supply assembly at the back of the host frame and the pins riveted in the host frame, then take it out from the back of the host.
4. AC weigher remove

7 System Diagnosis and Support

7.1 Starting Up

Starting Up	Solutions and measures
The collection does not work after starting up	Check whether the power cord is connected correctly or not
The display does not bright after starting up	Open the rear cover of the host to check whether the communication cable is connected to the place
Start-up self-test failure	Inquire solutions from section 8.1.2 according to the screen tips

7.2 Components Fault and Test

7.2.1 Tools required for Maintenance

Voltage Meter

Pressure Meter (measurement of positive & negative pressure in mmHg)

Calibrated Weights (200, 400, 600, 800, 1000g)

Digital and Optical RPM measure meter

Disposable for Testing

7.2.2 Power Pack

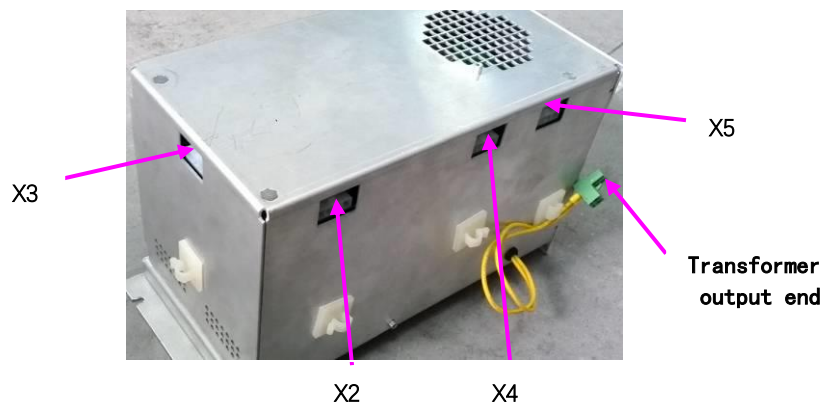

Figure 7-1 Power Supply Assembly Test Chart

1. Test for the output voltage of the transformer

Connect the power pack with the 230V/115V power supply by power cables, and measure the voltage is 230V at the output terminal of the transformer Test for the output voltage of the power pack

Connect the power pack with the 230V power supply by power cables, and measure the voltages of each pin (facing the socket and from left to right are pin 1, pin 2, pin 3, pin 4 and pin 5 respectively) of the connector socket X2, X3, X4 and X5, wherein requirements of the following table should be accorded:

Plug	X2		X3		X4		X5	
Pin Number	1 (+), 2 (-) 3 (+), 4 (-)							
Voltage ($\pm 0.5V$)	24V	12V	24V	12V	24V	12V	24V	5V

- Open the power pack, measure the input voltage (connector socket X1) of the DC power board by 200V DC grade of a multimeter, if the voltage can meet $24V \pm 0.5V$, the DC power board should be replaced, otherwise, the switching power supply should be replaced.

7.2.3 Weigher Startup to enter the weigher calibration interface or debug interface:

- Check the weighing result of the monitor by a 1000g weight, and check the function thereof.
- Set a target value 1000g firstly at the calibration interface of the weigher for calibration, and complete the calibration of 200g with the same method, wherein the error range is less than or equal to 5g.
- Repeat steps until values are in range, then test 400 – 800g.

7.2.4 Cuff

- Connect the pressure meter with the cuff;
- Inflate the cuff, modify the pressure by pressing cuff+ and cuff- until the reading on the pressure meter is about 50mmHg, adjust RP1 on the driver board if the tolerance $>5\text{mmHg}$; At this time confirm the voltage of TP5 between 4.80V and 5.20V.
- If the test value is still incorrect, check whether the cuff is leak or not, if not, replace the air pump, or replace the driver board if the test failed again.

7.2.5 DPM

1. Connect the pressure meter with a syringe to the DPM.
2. Use the test material to run the plasma separator into the collection phase, extract air by an injector to drop the pressure to -80mmHg, the collection interface will show the low pressure alarm for blood collection; turn to the return phase, boost the pressure to 250mmHg by the injector and the collection interface will show the return_high pressure alarm;
3. At the collection or return phase, remove the DPM connector, the interface shows DPM adapter drop_alarm;
4. If the DPM performance fails – replace it.

7.2.6 Line Sensor

1. Measure pin 2 and pin 4 of the line sensor connector the result should be $3.5V \pm 0.1V$;
2. If failed, regulate the line sensor board RP1 to meet the above requirement;
3. If still cannot meet the requirements, replace the line sensor.

7.2.7 Valve

1. Insert manually the tubing with the connected pressure meter and the syringe and apply 200mmHg to the tubing.
2. If pressure remains constant (no reduction). If pressure decreases, check tubing position, if still failing –change valve.
3. In the debugging interface, use the on/off of the valve to observe whether the action of the valve is correct, if not, replace the valve.
4. The sensor checks and adjusts, if the indicator is on/off by manually pressing and releasing of the knob, move the sensor to the appropriate position after loose the screw, then tight the screw; If the sensor not works, change it. See picture below.

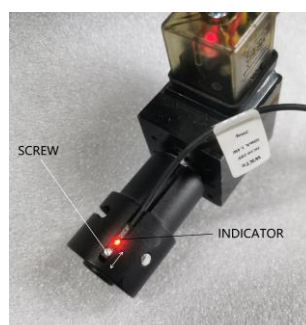

7.2.8 Pump

1. Check mechanical condition of rollers. If rollers are hard to turn or making noise, clean rollers or change the pump head.
2. Perform occlusion test – put tubing connected to a bag with fluid through the pump and check, if fluid is blocked by the pump rollers. Replace the pump head if failing.
3. On the debugging interface, set the pump speed as $20-150r/min \pm 2r / min$, measure the pump speed with a photoelectric tachometer, and observe the measured value and the displayed value which should be the same.
4. If failed, replace the pump driver and the pump motor respectively and test again.
5. Roller Check Specification
 - A. One year after the equipment is installed, the roller routine inspection is carried out by an authorized service engineer, after which the next check is half year and record it in a checklist.
 - B. Roller replacement cycle:
 - a) AC pump rollers need to be replaced when they have a service life of about 1 years;
 - b) When the blood pump roller has a life cycle of about 1 year, a new roller needs to be replaced.
 - c) The roller failure phenomenon description:

No	Failure Description
1	Abnormal noise.
2	Blood collection too fast, Returning too fast, Anticoagulant ratio too high
3	Wrong direction of the blood pump, Wrong direction of the AC pump
4	During the return, red blood cells be found to enter the anticoagulant line and approach the anticoagulant pump head.

- d) Check Item

No	Item	Check Content	Tool/Instrument
1	Rotation	Gently turn the roller with your finger to ensure that it rotates smoothly without resistance	
2	Appearance and size	Measure the diameter of the roller with a caliper to ensure that the diameter of the roller is between 18.6mm and 19.2mm (do not use force to clip when measuring, the metal surface just touch the polyurethane), polyurethane should be free of cracks, no slag, no shedding (non-conforming cases see drawings)	Caliper, Hex spanner
3	Hardness	To measure the polyurethane hardness of the outer ring of the roller, the hardness is between 60 and 70 degrees of shore hardness	Shore hardness meter
4	Sealing	The line be loaded into the pump head and then three-way connection lines, compress the syringe until the pressure value in the line reaches 300 mmHg, it is ok if leaks less than 5 mmHg in 30 seconds.	Three-way connector, Syringe, Pressure meter

Caution :	Rollers' pin can be accessed by removing the color sticker (don't forget to place them again)
---------------------	---

7.2.9 Centrifuge Assembly

1. Measure the speed (constant value, clockwise direction) of the centrifuge by the photoelectric tachometer, the tolerance is $\pm 2.5\%$ of specified speed in the operating manual.
2. Centrifuge speed: set parameters directly on the centrifuge driver by referring to appendix A;
3. Centrifuge switch test: in the collection phase (the centrifuge is running), switch on the centrifuge, the interface displays that the alarm of the centrifuge is not closed;
4. Leakage monitor test: press the stop button in the collection phase to suspend the program, use a cotton swab to apply water on the leakage monitor, re-operation, and the plasma separator interface will show the centrifuge bowl leakage alarm.
5. Centrifuge cover check

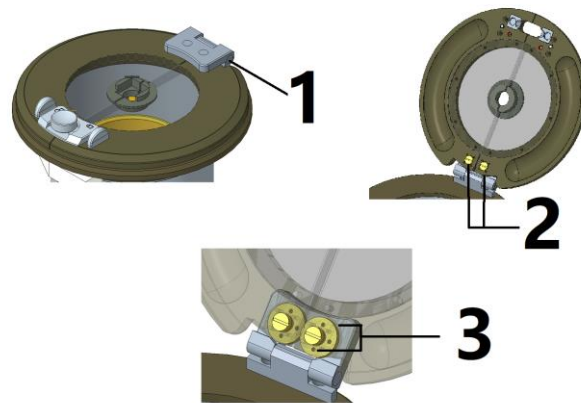

Check the points No1 No2 No3 each year or lid noise and tight the screws if it loose, pay special attention on the No 3, there is a pair of gears which locked by four small screws.

7.2.10 Air Detector

1. Insert an empty tubing into the air detector, the light on the detector remains on.
2. Insert a water filled tube and the light should go out.
3. In the collection phase, remove the pipeline with water contained form the air detector, the plasma separator interface displays the air alarm information (the blood air detector will make alarm after the collected whole blood is more than 30ml) of the corresponding air detector.

7.3 Alarm and Abnormal Information

Alarm Information	Fault Phenomenon	Solutions and Measures
High speed of centrifuge	The centrifuge speed is greater than +2.5%	Correct the speed of the centrifuge by referring to 8.2.9. If not work, replace the centrifuge driver or the centrifuge assembly.
Wrong direction of the pump	Draw phase: The blood pump runs anticlockwise, Return phase: The blood pump runs clockwise, The anticoagulation pump runs clockwise.	Detect the pump by referring to 8.2.8.
The control system is abnormal in communication		Replace the communication board or the system board or the driver board

8 Care and Maintenance

8.1 Summary

8.1.1 Purpose

In order to ensure the performance and the safety of the system, and extend the service life of the machine, regular care and maintenance should be applied to the plasma separator to guarantee the function and performance of the collection system in the using process as well as provide certain quality assurance for the product.

8.1.2 Tools, measuring equipment and Disposable

Table 8-1 List of Cleaning Supplies

Tools, measuring equipment and Disposable	QTY	Remarks
Cleaning solution		Specific to blood-borne pathogens is recommended
Clean warm water		
70% alcohol		
Hairless cleaning cloth	1	
Screwdriver	1	
Cotton swab		
Lubricant		
Voltage Meter	1	
Pressure Meter	1	measurement of positive & negative pressure in mmHg
Calibrated Weights	1 group	(200、400、600、800、1000g)
Disposable for Testing	1	
Digital and Optical RPM measure meter	1	
Leakage current meter	1	

Caution: 1. Do not use deliquescent solvent (such as paint thinner or gasoline) or abrasive cleaner to clean the machine, or the system might be damaged.

2. It is forbid to use cleaner with hydrocarbon or for OA devices to clean the display screen.

8.1.3 Care and Maintenance Frequency

Table 8-2 List of Maintenance Frequency

Maintenance Contents	Frequency	Methods
Clean all external surfaces	After each time of use, 1 time per day	Refer to 8.2.2
Clean DPM	After each time of use, 1 time per day	Ditto
Clean air detector	1 time per week	Ditto
Clean line sensor	1 time per week	Ditto
Clean inner wall of centrifuge	1 time per week	Ditto
Clean leakage sensor	1 time per week	Ditto
Clean cuff	1 time per month	Ditto
Clean air filter	1 time per half a year	Ditto
Weigher calibration	1 time per month	Ditto
Electrical safety maintenance	1 time per year	Refer to 8.4
Machinery safety maintenance	1 time per year	Ditto
Performance test	1 time per year	Refer to 8.4.2
Peripherals and components inspection	1 time per year	Refer to 8.3.2

8.2 Cleaning System

8.2.1 Cleaning Procedures

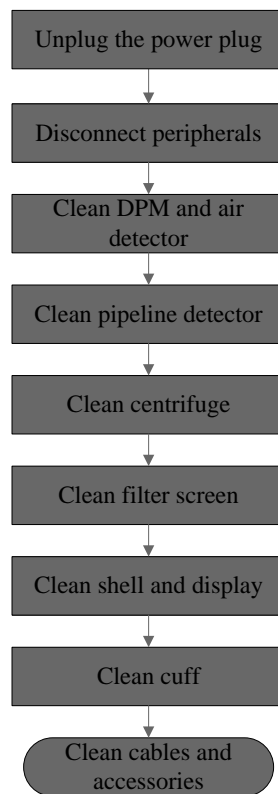

Figure 8-1 Flowchart of Cleaning and Maintenance



Warning:

Before cleaning the product, turn off the power switch of the product and unplug the power plug from the socket. Otherwise, it may result in electric shock.

8.2.2 Content

1. Display screen

Wipe the display screen with a soft cloth immersing with glass cleaner and then air dry.

2. Pressure monitor for blood tubes

Clean the pressure monitor with clean water, and dry the monitor with a dry hairless cleaning cloth.

3. Air detector

Clean the pipe chase and surface of air detector with 70% medicinal alcohol and hairless cleaning cloth.

4. Tubes detector

Clean the tubes detector with clean water, and dry the detector with a dry hairless cleaning cloth.

5. Inner wall of the centrifuge

a. Routine cleaning

- Clean the inner wall and cup holder of the centrifuge with a cleaning cloth immersing with cleaning solution. For routine maintenance, no large quantity of cleaning solution is required;
- Clean the centrifuge cover with a cleaning cloth immersing with cleaning solution;
- Dry all surfaces with a dry cloth.
- Lubricate the O ring inside the cup holder of centrifuge with a little vacuum grease every month. It is not necessary to take out the O ring when lubricating. See the figure below:

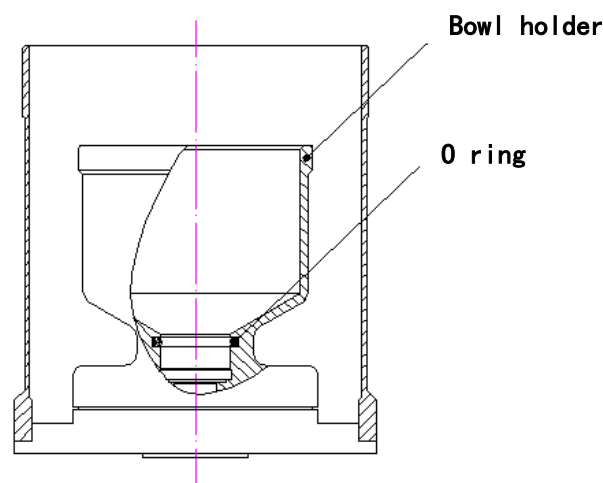

b. Cleaning when there is liquid leakage

- Turn off the power supply and pull the plug;
- Clean the centrifuge cover with a cleaning cloth immersing with cleaning solution, and then dry with a dry cloth;
- Clean the inner tank and bowl holder with a cleaning cloth immersing with cleaning solution;
- Clean the leakage sensor with a cotton swab dipping with 70% alcohol.

c. Cleaning when there is oozing of blood

- Turn off the power supply and pull the plug, ensure the waste liquid bag is connected to the discharge pipe;
- Clean the centrifuge cover with a cleaning cloth immersing with cleaning solution, and then dry with a dry cloth;
- Clean the inner wall and cup holder with a cleaning cloth immersing with cleaning solution;
- Fill the injector of 50ml with cleaning solution;
- Squeeze out the cleaning solution from the discharge hole of centrifuge bowl holder, and rinse repeatedly until it is clean;
- Clamp the waste liquid bag, remove it for processing, and replace with a clean waste liquid bag;
- Each time after oozing of blood, lubricate the O ring with a little vacuum grease without taking out the O ring.

6. Leakage sensor

Clean the leakage sensor with a cotton swab dipping with 70% alcohol.

7. Filter screen

The filter screen is at the bottom of case.

- Unscrew the retainer in the filter screen with a cross screwdriver;
- Pull out the filter screen;
- Rinse the filter screen with warm water;
- Put the filter screen in a soft cloth that is clean and dry to completely dry it;
- Reinstall the filter screen and retainer at the bottom of case.
- Addition: The filter screen can also be cleaned with mini vacuum cleaner.

8. Cuff

Take out the outerwear of cuff, clean with a cleaning cloth immersing with cleaning solution or cleaning solution, and put in a cool and ventilated place for drying.

9. Cable/signal wires

- Visual test to make sure that the cable surface has no crack or broken mark;
- Use a soft dry cloth to wipe the dust or dirt adhered to the cable surface of the probe;
- If there is still a stubborn stain that is difficult to remove, use soft cloth dipped with neutral detergent to wipe the stain, and then dry in air.

10. Case surface

Regularly clean the external surface of plasma separator including the operating panel with cleaning solution.

8.3 Maintenance Check

The maintenance check must be done by maintenance engineers of Nigale who have professional knowledge or skills or engineers obtaining the skills by training.

8.3.1 System Function

Table 8-3 List of System Function

Steps	Content	Description
1	Collection mode	Check the basic operations of the collection mode. Inspect some basic software or hardware controls that may affect related operations of the collection mode.
2	Configuration function	Check the basic operations of the function configuration
3	Maintenance function	Check the basic operations of the system maintenance. Inspect some basic software or hardware controls that may affect related operations of the collection mode.

Note: refer to **4.4** Functional examination for the specified methods

8.3.2 Inspection of Peripherals and Fittings

Table 8-4 List of Inspection of Peripherals and Fittings

Steps	Contents	Description
1	Barcode scanner	Inspect whether the scanner works normally or not, and clean the scanner window if necessary
2	UPS	Refer to 4.3.2.5 to inspect the performance of UPS
3	Software management	Inspect basic operations of the user, verify the realization of the functions of the software management and the network connection

8.4 System Maintenance

8.4.1 Electrical Safety Maintenance

The electrical safety maintenance is mainly aimed at the system leakage current inspection. The frequency of this test should be decided by each individual user based on their operating times and environment. If dust is present inside the device, we recommended that a portable vacuum cleaner or compressed air can be used.

If fluid is found on the inside of the machine, it must be cleaned and make a current leakage check (to make sure fluid doesn't ruin the circuit) by a qualified service engineer before the machine can be used.

To pass the inspection, the earth ground leakage must not more than 100 μ A at 110VAC or 500 μ A at 220VAC.

8.4.1.1 Ground Continuity

1. Set the LT544 leakage tester (**or equivalent instrument**) to RESISTANCE, connect with the Digipla.
2. Change the meter mode to measure resistance at 0 - 200 milliohms.
3. Plug the ground wire (coiled wire with clip) into the green socket.
4. Attach the clip to the following exposed metal locations. Verify that there is continuity to the test points, record the highest reading (less 160 milliohms LT544 resistance) on the service report.
 - Pump Rotor Screw
 - Rear Cover Hardware
 - Centrifuge Cover Hinge
 - Front Cover Hardware
 - Pinch Valves Plunger
 - Right Side Bag Pins

8.4.1.2 Leakage Current

1. Connect the Digipla to the LT544 Leakage Tester (or equivalent instrument) and plug the LT544 into a grounded electrical outlet.
2. Select LEAKAGE mode of operation on the LT544.
3. Plug probes from the LT544 onto a DVM. The red probe into mV receptacle, the black probe into the GND receptacle.
4. Set the meter to 0- 200 mV AC.
5. Set the NORMAL /REVERSE switch to NORMAL.
6. Open the Ground switch and repeat with the power on, then power off.
7. Verify the readings in all four test modes are < 500 micro amperes for 220V.
8. Reverse polarity and repeat the previous step.

9. Record the highest value.

8.4.2 Machinery Safety Maintenance

The machinery safety maintenance mainly refers to test the mechanical strength and functions of critical components of the plasma separator. The detection and evaluation methods mainly comprise: visual inspection and operational check, if the results cannot pass, the system is proved to be in abnormal state that it must be stopped and appropriate measures should be taken.

Table 8-5 List of Machinery Safety Test

Items	Standards	Tools
Display	<ol style="list-style-type: none"> 1. Visual test, make sure the display does not lean left or right 2. The connection between the display and the host does not loose 	Philip's head screw
Handle	<ol style="list-style-type: none"> 1. Visual test, make sure the left handle and the right handle of the equipment have no crack 2. Pull the handle manually to make sure the handle does not loose 	Philip's head screw
Weigher Strut/tray	<ol style="list-style-type: none"> 1. Visual test, make sure the structural integrity of the strut/tray 2. Pull by hands to make sure the connection of the strut/tray is firmly without shaking 	No
Cable connection	<ol style="list-style-type: none"> 1. Visual test, make sure the internal cable and external cable of the equipment have no damage or tooling mark. 2. Checking manually to make sure the internal cable connection of the equipment does not loose or drop 	Philip's head screw
Other mechanical structures	Make sure there is no other loose part, shell cracking and loose, and no exposed conductive parts	No

9 Appendix

9.1 Setting of Centrifuge Driver

A. Old Version (Type: VFD-L, the picture in this manual is new version)

Group 1: Basic Parameters

Pr.	Functions	Settings	Pr.	Functions	Settings
1-00	Maximum operation Freq.	125/118	1-10	Decel time 1	40.0
1-01	Maximum setting Freq.	125/118	1-11	Accel time 2	10.0
1-02	Maximum output voltage	95.0	1-12	Decel time 2	10.0
1-03	Mid-point Freq.	1.0	1-13	JOG Accel time	10.0
1-04	Mid-point voltage	12.0	1-14	JOG Decel time	10.0
1-05	Minimum output Freq.	1.0	1-15	JOG frequency	6.0
1-06	Minimum output voltage	12.0	1-16	Auto-accel/decel	0
1-07	Upper bound of freq.	100	1-17	S-curve setting in acceleration	0
1-08	Lower bound of freq.	0	1-18	S-curve setting in deceleration	0
1-09	Accel time 1	30.0			

* Centrifuge speed: 7500/7000 rpm

Group 2: Operation Method Parameters

Pr.	Functions	Settings	Pr.	Functions	Settings
2-00	Source of frequency	0	2-04	Reverse operation inhibit	0
2-01	Source of operation Command	2	2-05	ACI(4~20mA) input loss detection	0
2-02	Stop method	0	2-07	Lone Start Lockout	0
2-03	Carrier freq.	10			

B. New Version (Type: ME300, the picture in this manual is new version)

No	item	value
1	00-21	1
2	00-31	1
3	01-00	125
4	01-01	125
5	01-02	95
6	01-03	10
7	01-04	25
8	01-05	3
9	01-12	30
10	01-13	40
11	05-04	2
12	06-00	150
13	06-01	420
14	06-49	1
15	07-23	1
16	07-26	1
17	07-32	8000

Calibration Record

Calibration Record		SN – Nr.:		
Report No.		Software:		
1.	Initial Inspection	8.	Clamp Test:	
	Check machine for visible damages or contamination Clean if required:		Occlusion test:	
	<input type="checkbox"/> OK <input type="checkbox"/> NOK		<input type="checkbox"/> OK <input type="checkbox"/> NOK	
	All safety relevant labels and stickers are available and not contaminated/good readable		Occlusion test:	
	<input type="checkbox"/> OK <input type="checkbox"/> NOK		<input type="checkbox"/> OK <input type="checkbox"/> NOK	
2.	Execute Auto test:	9.	Pump Test:	
			Check Pump Head Rollers:	
			Occlusion test:	
	Check of correct fuses:		Pump Speed:	
	<input type="checkbox"/> OK <input type="checkbox"/> NOK		Blood Pump 80 rpm	77 =< <input type="checkbox"/> =< 83
			AC Pump 5 rpm	4 =< <input type="checkbox"/> =< 6

		OK			NOK					OK			NOK																
3.	Check DC Voltages:														10.	Centrifuge Test:													
	TP1	4,80 V =<																											
	TP2	3,20 V =<																											
	TP3	4,80 V =<																											
	TP4	11,50 V =<																											
	TP5	4,80 V =<																											
	TP6	23,50 V =<																											
	TP7	3,20 V =<																											
	TP8	11,50 V =<																											
	TP9	-12,50 V =<																											
	TP10	4,80 V =<																											
	Blood Pump	23.50 V =<																											
	AC Pump	23.50 V =<																											
		OK			NOK																								
4.	Check Weigher:														11.	Air detector Test:													
	0g	0g =<																											
	200g	195g =<																											
	400g	395g =<																											
	600g	595g =<																											
	800g	795g =<																											
	1000g	995g =<																											
		OK			NOK																								
5.	AC weigher Test: 0g 200g T F														12.	Electrical Safety Test (IEC 60601 -1):													
	Cuff Test:															Ground Continuity:													
	No leakage															< 1 Ω													
		OK			NOK																								
6.	Line sensor:														13.	Used Tools:													
	3,50V	3,40 V =<																											
		OK			NOK																								
7.	DPM Test:														14.	The device is ready for further use according to the manufacturer guidelines and manuals – released.													
	Draw Alarm - 80mmHg	-85mmHg =<																											
	Return Alarm 250mmHg	240mmH =<																											
	Interlock Test	OK			NOK																								
Comments:														Yes		No													
Date:				Place:				Technician name:				Sign:																	

9.2 Spare Parts View

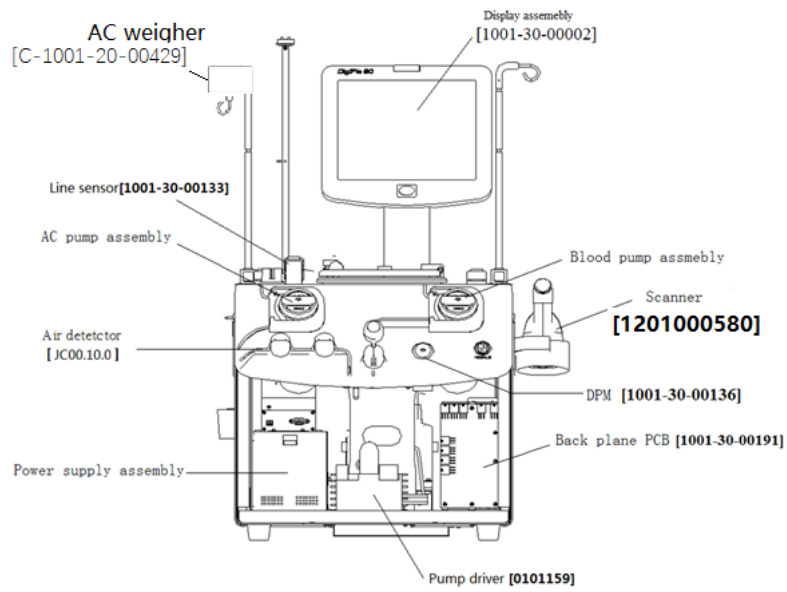

Figure 9.1 FRONT VIEW

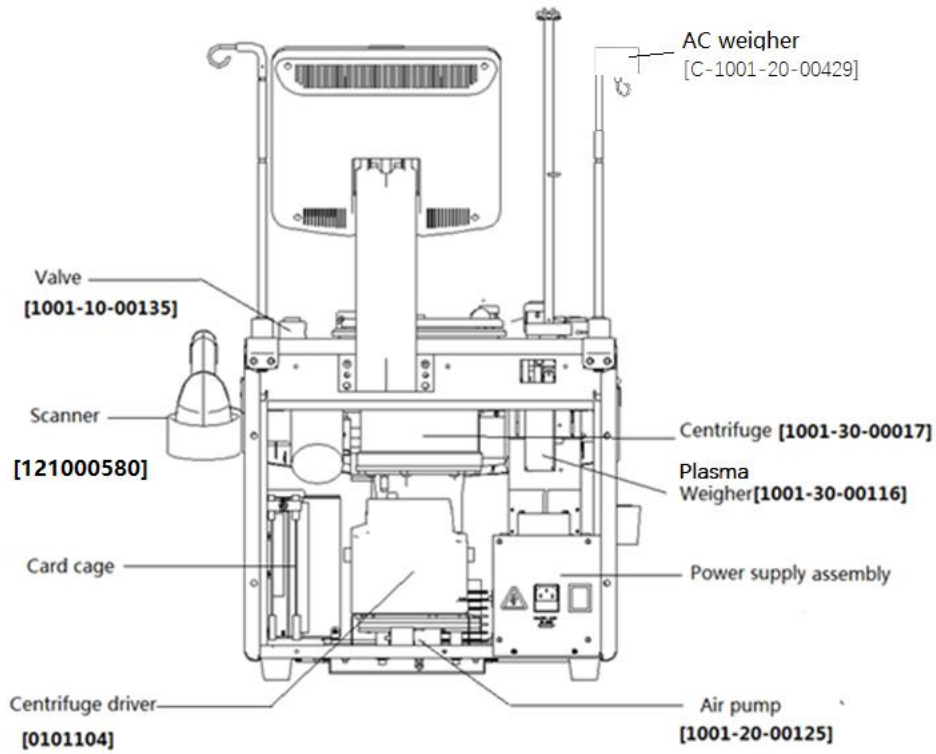

FIGURE 9.2 BACK VIEW

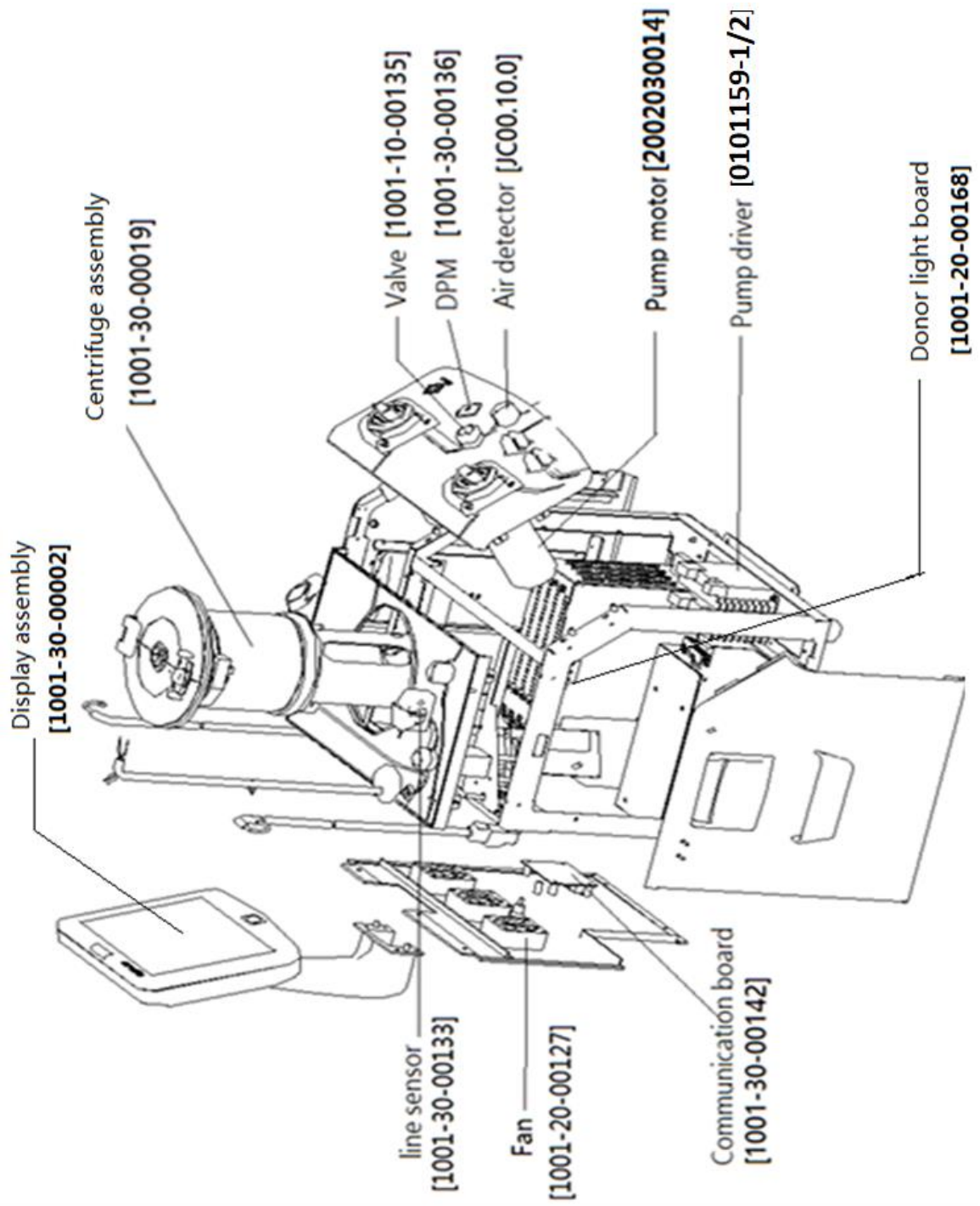

FIGURE 9.3 LEFT SIDE VIDW

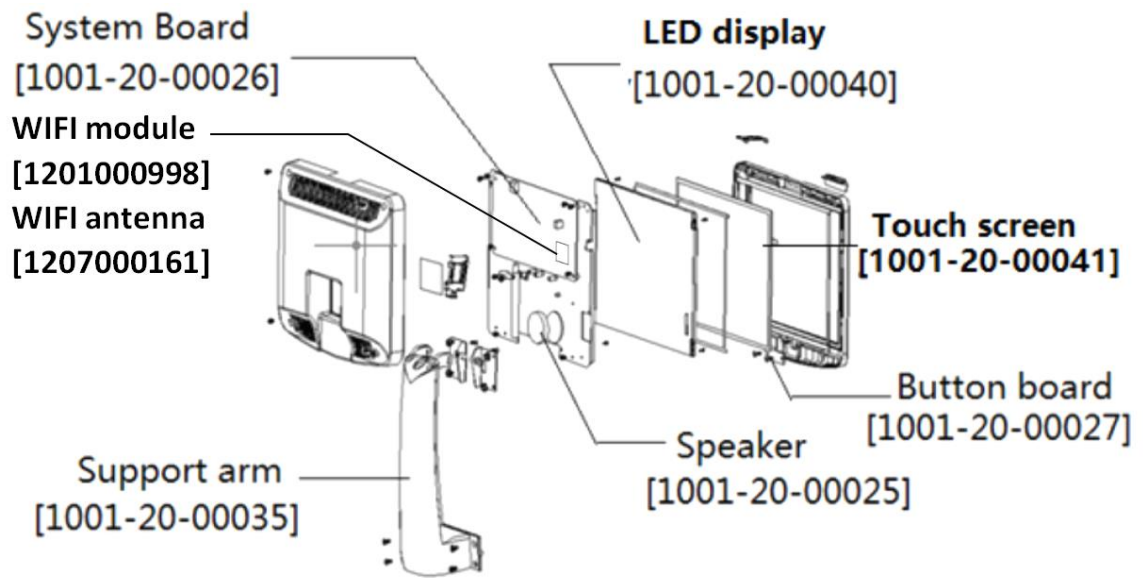

FIGURE 9.4 DISPLAY ASSEMBLY

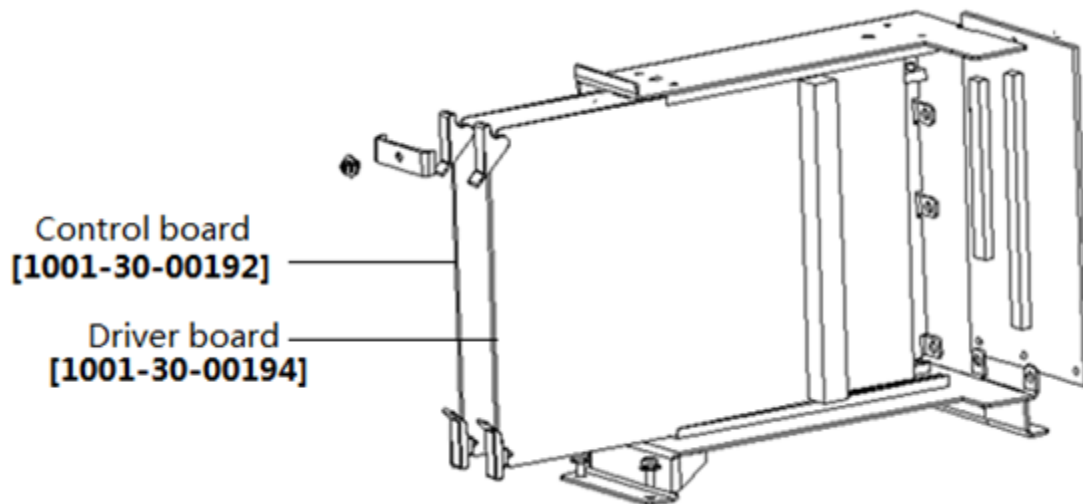

FIGURE 9.5 CARD CAGE

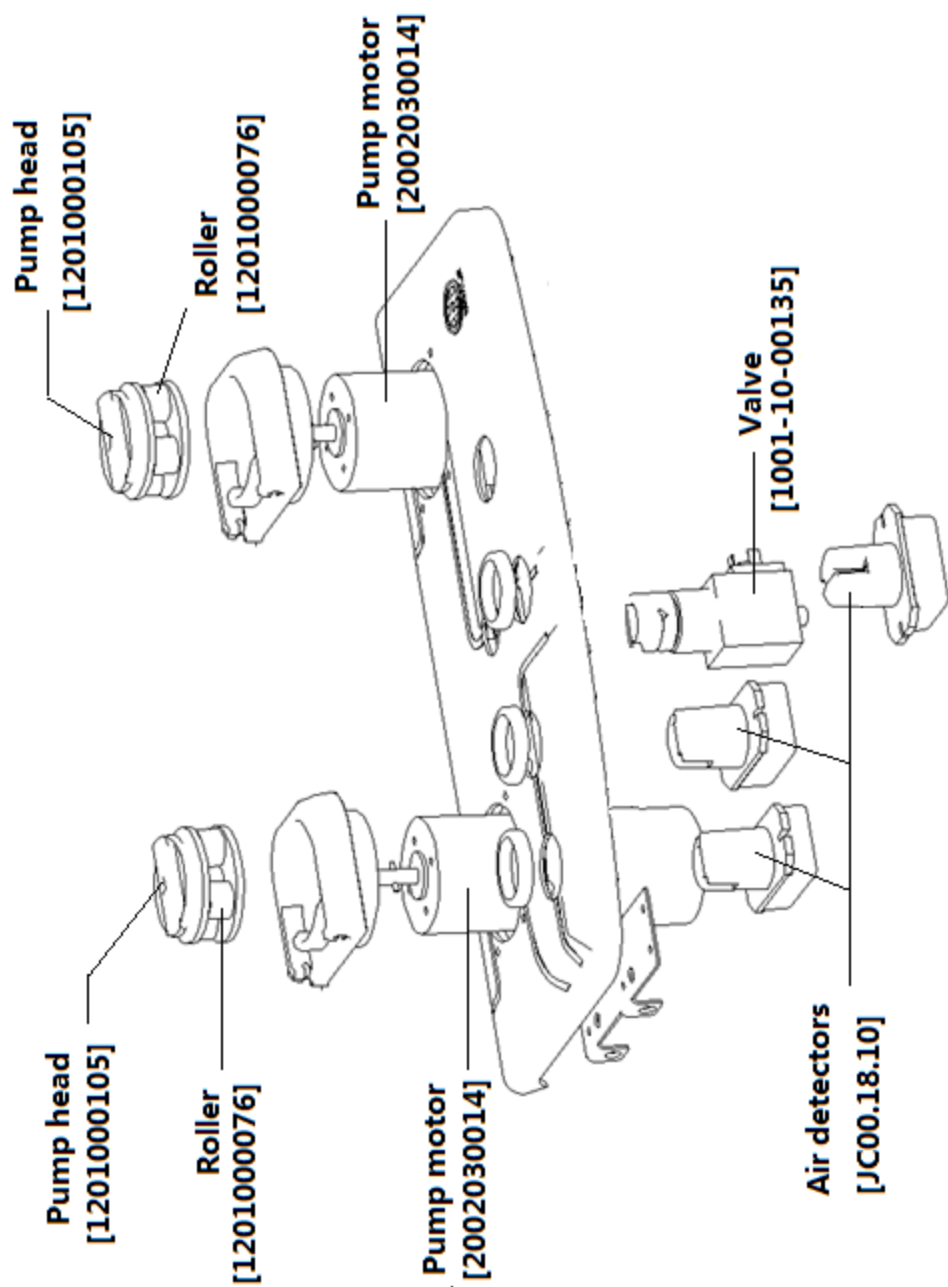

FIGURE 9.6 Top deck

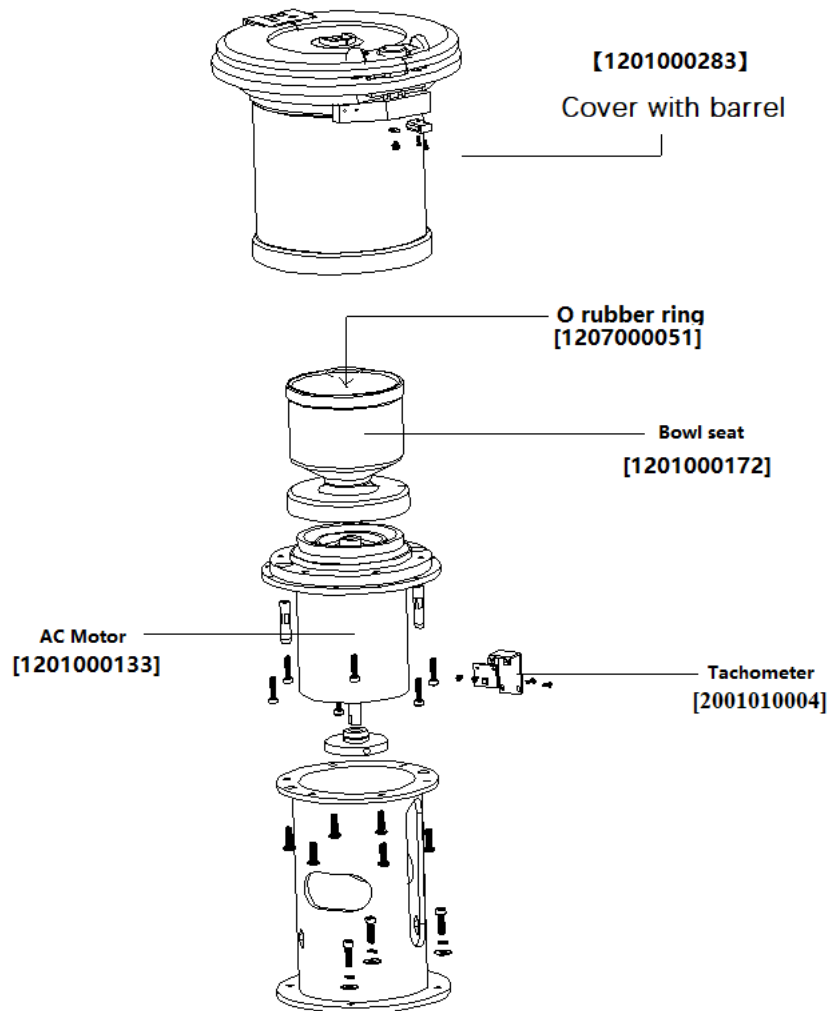

FIGURE 9.7 Centrifuge assembly

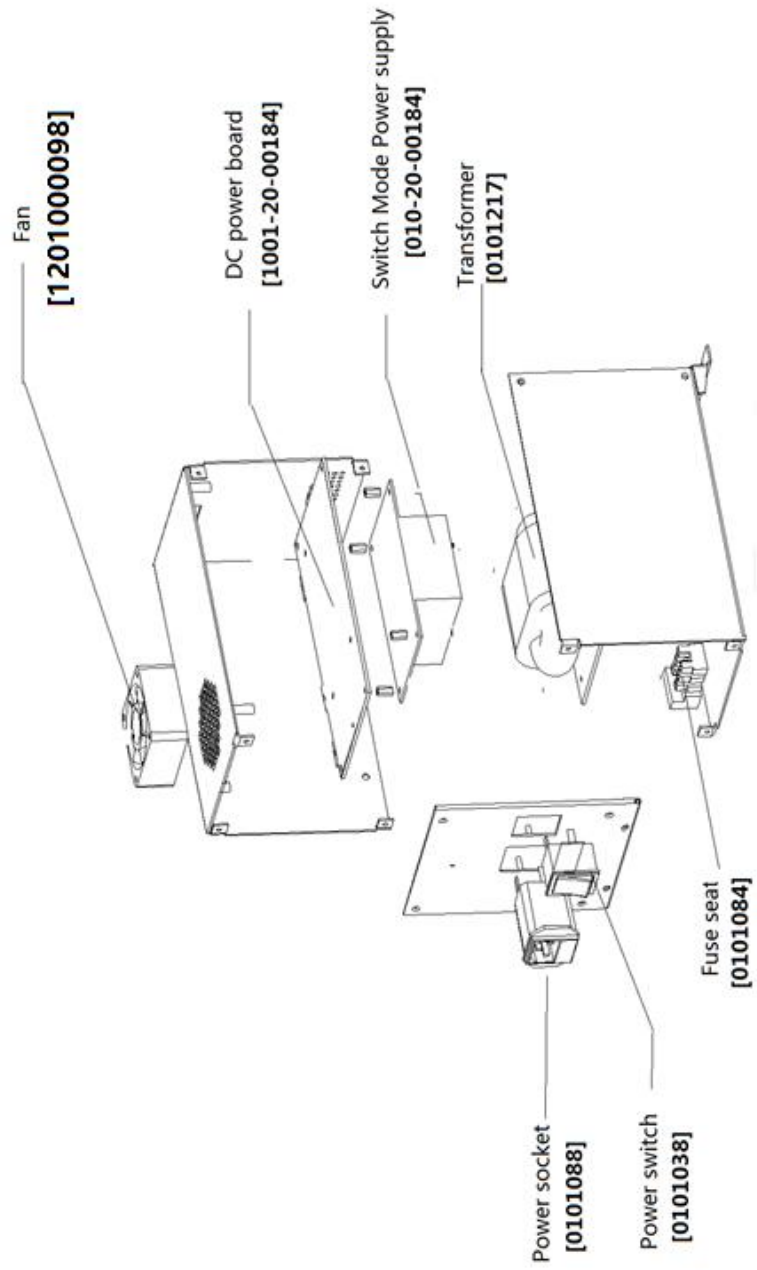

FIGURE 9.8 POWER SUPPLY ASSEMBLY

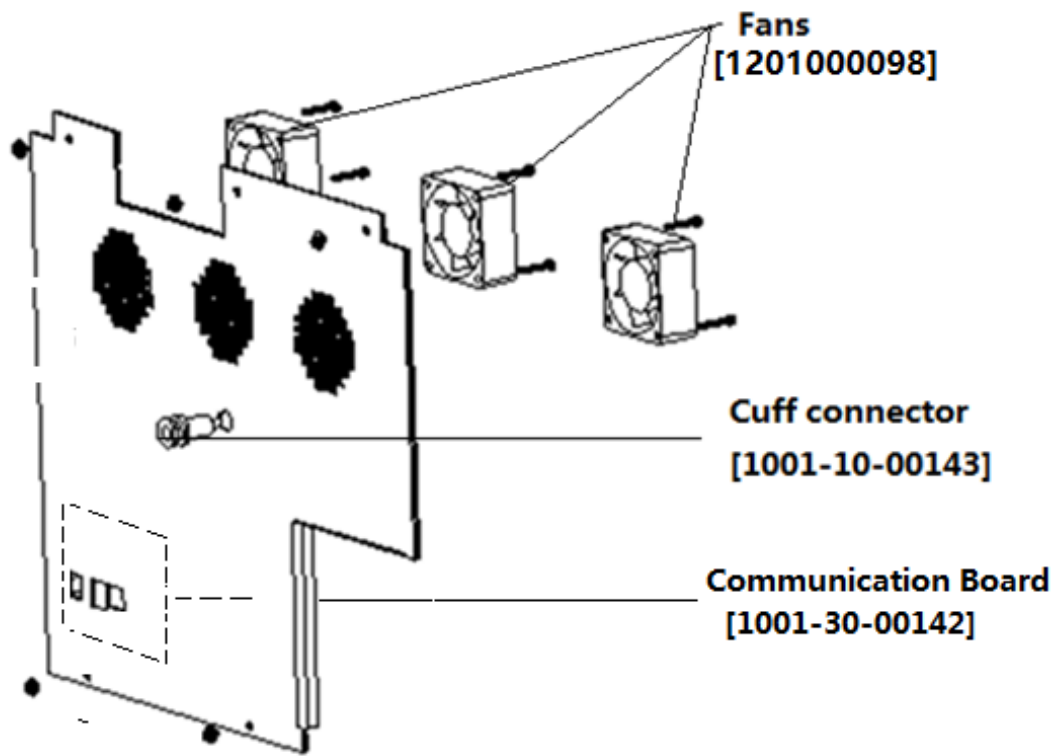

FIGURE 9.9 BACK COVER

9.3 Spare Parts List

No	Description	Code	Map
1	*Control board*控制板	1001-30-00192	FIG. 1.5
2	Driver board 驱动板	1001-30-00194	FIG. 1.5
3	Backplane board 背板	1001-30-00191	FIG. 1.1
4	Communication board 通信板	1001-30-00142	FIG. 1.3; FIG. 1.9
5	Donor light board 提示板	1001-20-00168	FIG. 1.3
6	Blood pump driver 数字交流伺服电机驱动器(血泵)	0101159-1	FIG.1.1; FIG.1.3
7	AC pump driver 数字交流伺服电机驱动器(抗凝剂泵)	0101159-2	FIG.1.1; FIG.1.3
8	Pump motor 交流无刷伺服电机	2002030014	FIG.1.3; FIG. 1.6
9	Pump head 双开口泵头	1201000105	FIG. 1.6
10	Roller 滚轮	1201000076	FIG. 1.6
11	Air detector 超声波空气探测器	JC00.10.0	FIG. 1.3
12	Line sensor 管路探测器组件	1001-30-00133	FIG. 1.3
13	Plasma Weigher 电子秤组件	1001-30-00116	FIG. 1.2
14	AC Weigher 抗凝剂电子秤组件	C-1001-20-00429	FIG. 1.2
15	DPM 血液管路压力检测器	1001-30-00136	FIG. 1.1
16	Valve 电磁阀组件	1001-30-00135	FIG. 1.3
17	Scanner 扫描枪	1201000580	FIG. 1.1; FIG 1.2
18	Display assembly 显示器组件	1001-30-00002	FIG. 1.4
19	*System board*系统板	1001-20-0026	FIG. 1.4
20	WIFI module WIFI 模块	1201000998	FIG. 1.4
21	WIFI antenna WIFI 天线	1207000161	FIG. 1.4
22	Touch screen 触摸屏	1001-20-00041	FIG. 1.4
23	LED display LED 显示器	1001-20-00040	FIG. 1.4
25	Support arm 支臂	1001-20-00035	FIG. 1.4
26	Button board 按钮板	1001—20-00027	FIG. 1.4
27	Speaker 扬声器	1211001032	FIG. 1.4
28	Centrifuge driver 交流电机驱动器	0101104	FIG. 1.2
29	Centrifuge assembly (7500rpm)	1001-30-00019	FIG.1.2; FIG. 1.7

	离心机 (7500 转)		
30	Centrifuge assembly (7000rpm) 离心机 (7000 转)	1001-30-00019	FIG.1.2; FIG. 1.7
31	AC motor 交流电动机	1201000133	FIG. 1.7
32	Cover with barrel 上筒	1201000283	FIG. 1.7
33	Bowl seat 杯座	1201000172	FIG. 1.7
34	O rubber ring O 型密封圈	1207000051	FIG. 1.7
35	Tachometer 离心机测位板	2001010004	FIG. 1.7
36	Fan 风扇	120100098	FIG. 1.9
37	Power socket 滤波器	0101088	FIG. 1.8
38	Power switch 电源开关	0101038	FIG. 1.8
39	Fuse seat 保险丝管	0101084	FIG. 1.8
40	DC power board 电源板	1001-20-00184	FIG. 1.8
41	R80 Transformer R 型变压器	0101217	FIG. 1.8
42	Switching power supply 开关电源	0101034	FIG. 1.8
43	Cuff 袖带	1270000142	N/A
44	Air pump 加气泵组件	1001-20-00125	FIG. 1.2
45	Cuff connector 袖带接头	1001-10-00143	FIG. 1.9
46	Air pump holder 加气泵支架	C-1001-20-00124	N/A
47	Communication Cable 通信线	1001-20-00043	N/A

*Note: The default version of software is the latest, if client needs previous versions, must be noted in the order.