

About This Manual

P/N: 4710-01041A06

Software Release Version: V 1.0

Release Date: February, 2023

Product Model: HD-550Exp/HD-550/HD-550Pro/HD-550S/HD-510/HD-500Plus

Copyright © 2017-2023 SonoScape Medical Corp. All Rights Reserved.

Statement

SonoScape Medical Corp. (hereinafter called SonoScape) owns the intellectual property rights to this manual, and also maintains the contents of this manual as confidential information. This manual is a reference to operation, maintenance and cleaning for the product and does not convey any license under the patent rights of SonoScape, nor the rights of others.

This manual contains the information protected by copyrights or patents. Reproduction, amendment or translation of this manual in any manner whatsoever without the written permission of SonoScape is strictly prohibited.

All information contained in this manual is believed to be correct. SonoScape shall not be liable for errors contained herein or for incidental or consequential damages in connection with the furnishing, performance or use of this manual. SonoScape does not assume any liability arising out of any infringements of patents or other rights of third parties.

This manual is based on the maximum configuration and therefore some contents may not apply to your product. Illustrations in this user manual are provided for operating instruction only and may be different from what is displayed on the screen or device.

This manual is subject to change without prior notice and legal obligation.



Manufacturer's Responsibility

SonoScape is responsible for the effects on safety, reliability and performance of this product, only if all the following requirements are met.

- All installation operations, expansions, changes, modifications and repairs of this product are conducted by SonoScape authorized personnel.
- The use or application of the product or the use of parts or accessories is approved by SonoScape.
- The electrical installation of the relevant room complies with the applicable national and local requirements.
- The product is used in accordance with the instructions for use.

Documentation

Understand the meanings of the following items clearly before reading this manual.

Item	Meaning
	Indicates a potentially hazardous situation which, if not avoided, could result in death or serious injury.
	Indicates a potentially hazardous situation which, if not avoided, may result in malfunction or damage of the system.
NOTE	Indicates precautions or recommendations that should be used in operating the system.
Word	Indicates controls on the control panel, or on-screen objects such as menu items or keys.
Click	Move the cursor to the controls on the display and press the confirm key on the control panel.

Item	Meaning
>	Select a menu item or a key following the path.

Contact Information

Manufacturer: SonoScape Medical Corp.

Address: Room 201 & 202, 12th Building, Shenzhen Software Park Phase II, 1 Keji Middle 2nd Road, Yuehai Subdistrict, Nanshan District, Shenzhen, 518057, Guangdong, China

Tel: +86-755-26722890

Fax: +86-755-26722850

E-mail: sonoscape@sonoscape.net

www.sonoscape.com

EU Representative: Shanghai International Holding Corp. GmbH (Europe)

Address: Eiffestrasse 80, 20537 Hamburg, Germany

Tel: +49-40-2513175

Fax: +49-40-255726

E-mail: shholding@hotmail.com

Contents

1	Safety	1
1.1	Intended Use	1
1.2	Device Compatibility	1
1.3	Safety Precautions	1
1.3.1	Electrical Safety	1
1.3.2	Accessory Safety	2
1.4	Safety Symbols	2
2	Overview	5
2.1	Packing	5
2.2	Component Introduction	5
2.2.1	Front Panel	5
2.2.2	Rear Panel	7
2.2.3	Side Panel	8
2.3	Keyboard	9
2.4	Main Screen	11
3	Preparations	13
3.1	Placing the Device	13
3.2	Installing the White Balance Cap Holder	14
3.3	Connecting the System	15
3.3.1	Connecting the Light Source	16
3.3.2	Connecting the Monitor	16
3.3.3	Connecting the Keyboard	17
3.3.4	Connecting the Footswitch	17
3.3.5	Connecting the Video Printer	18
3.3.6	Connecting the Report Printer	19
3.3.7	Connecting to the Network	20
3.3.8	Connecting the Power Supply	20
3.4	Inspecting the Device	20
3.4.1	Inspecting System Connection	20
3.4.2	Inspecting Power Supply	20
3.4.3	Inspecting Illumination	20
3.4.4	Inspecting Image	21
3.4.5	Inspecting the Freezing Feature	21
4	Operations	23
4.1	Powering on the Device	23
4.2	Entering the System	23
4.2.1	Selecting the Login Mode	23
4.2.2	Managing Accounts	24
4.3	Entering Patient Information	26
4.3.1	Entry in Advance	26
4.3.2	Entry During Examination	29
4.4	Setting the Work Mode	29
4.5	Replacing the Endoscope	32
4.6	Adjusting the Monitor	32

4.7	Optimizing the Image.....	32
4.7.1	Adjusting the White Balance.....	32
4.7.2	Magnification.....	33
4.7.3	Color Enhancement.....	33
4.7.4	Red-blue Pseudo-color Image Display.....	33
4.7.5	Image Enhancement.....	33
4.7.6	Contrast.....	33
4.7.7	Switching the Illumination Mode.....	33
4.8	Managing Images and Videos.....	33
4.8.1	Saving Images and Videos.....	34
4.8.2	Viewing Images and Videos.....	35
4.9	Managing Patient Record List.....	36
4.10	Editing and Printing Reports.....	40
4.10.1	Annotating Images.....	40
4.10.2	Glossary.....	42
4.10.3	Setting Report Template.....	44
4.10.4	Uploading Reports to DICOM sever.....	44
4.10.5	Printing a Report.....	44
4.11	Powering Off the Device.....	44
5	Settings.....	47
5.1	Video Parameter Settings.....	47
5.2	General Settings.....	49
5.3	Contextual Model Settings.....	50
5.4	DICOM Settings.....	51
6	DICOM.....	57
6.1	DICOM Connection.....	57
6.2	DICOM Storage.....	57
6.3	DICOM Worklist.....	58
6.4	MPPS.....	58
6.5	Storage Commitment.....	58
6.6	DICOM Queue.....	58
7	Maintenance and Storage.....	61
7.1	Cleaning the Device.....	61
7.2	Replacing the Fuse.....	61
7.3	Storing the Device.....	62
7.4	Troubleshooting.....	62
7.5	Device Disposal.....	63
7.6	Customer Service.....	63
	Appendix A Specifications.....	64
	Appendix B EMC Guidance and Manufacturer’s Declaration.....	66
B.1	Electromagnetic Emissions.....	66
B.2	Electromagnetic Immunity.....	66

1 Safety

This chapter describes important information for operating this device. To ensure the safety of both operator and patient, please read relevant details in this chapter carefully before use.

The operator should be completely familiar with the precautions provided in this manual. Otherwise, the manufacturer is not responsible for the effects on safety, reliability and performance of the device.

1.1 Intended Use

The device is intended to provide image processing functions for endoscopic image in clinic. It is used with the endoscopes provided or approved by the manufacturer and to provide power for endoscope.

The device should be used in the medical institution. The operator of the device should be a physician or a medical staff supervised by a physician, both of whom have received sufficient training in clinical endoscopy technology.

NOTE:

- *Strictly follow the intended use to operate the device.*
- *The device should be used with BF-type endoscope.*

1.2 Device Compatibility

The device is used with the endoscope (EG-550 series, EC-550 series, EB-5H20 series, EG-UC5T, EG-UR5, EC-P550S series, EC-P560 series, EG-P550N, EC-550Z and EG-550Z) and the light source (VLS-50 series or VLS-55 series) provided or approved by the manufacturer.

1.3 Safety Precautions

Read and understand all precautions in this manual before attempting to use the device. Keep this manual with the device at all times. Periodically review the procedures for operation and safety precautions.

1.3.1 Electrical Safety



- Only the personnel authorized or trained by the manufacturer can maintain the device. Any unauthorized personnel should not assemble or disassemble the device.
- Do not operate the device in an atmosphere containing flammable gases such as anesthetic gases, hydrogen or ethanol, because there is a danger of explosion.
- Connect the protective earth conductor only before powering on the device. Disconnect the ground wire only after powering off the device. Otherwise, electrical shock may occur.
- Do not service or maintain the device while it is in use with a patient.
- Do not position the device to make it difficult to disconnect it.
- Connect the device to other electrical equipment by using the potential equalization lead wire before connecting the power plug of the device to an electrical outlet.
- Do not place the multi-socket outlet on the floor.

- Within the environment that is 1.8 meters (6 feet) around a patient, connect peripherals to the auxiliary power outlet which is capable of isolation protection; or, power the peripherals by the auxiliary output cable or the isolation transformer complied with EN/IEC 60601-1, or the power input of the same safety level.
- Do not pour any fluid onto device surfaces, as fluid seepage into electrical circuitry may cause excessive electrical current leakage or device failure. If any water is spilled onto the device carelessly, stop using the device and contact the local distributor immediately.
- The AC power connector plug for the device is a three-prong grounded plug and should never be adapted to any two-prong outlet or by using an adapter. Connect the AC power plug of the multi-socket outlet to a hospital-grade power outlet.
- Disconnect the power cable from the electric outlet to ensure that the device is powered off.
- Do not connect the device and high frequency surgical instrument to the same power outlet. Place the device away from high frequency surgical instrument.
- Place the device away from the laser instrument which has a high starting voltage.
- A spare image processor is recommended to be placed in the examination room in case the device appears abnormal.
- The performance of the device and its accessories may be degraded over time. Perform periodic maintenance as described in this manual to ensure the safety of the device.
- Maintain and store the device as described in this manual after use. Improper maintenance and storage may cause cross infection, damage to the device or performance degradation.
- Do not touch the patient and the ports of the device simultaneously. Otherwise, there is a danger of electric shock.



- Select a qualified multi-socket outlet with protective grounding, and ensure that its maximum output power exceeds the required one of the device.
- The multiple socket-outlet can only be used to provide power to the recommended peripherals of this system.
- Do not connect other devices to the multiple socket-outlet. Otherwise, it may result in interference and overload.
- If the non-medical electrical equipment used with the system is supplied by a multiple socket-outlet with separating transformer, connect the AC power plug of the multiple socket-outlet to a hospital-grade power outlet. Consult a professional to ensure that the connection complies with the safety standards.
- Accessory equipment connected to analog and digital interfaces must be certified according to the respective EN/IEC standards (for example, EN/IEC 62368-1 for data processing equipment and EN/IEC 60601-1 for medical equipment). Furthermore, all configurations shall comply with EN/IEC 60601-1.

1.3.2 Accessory Safety





















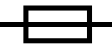



Only the accessories provided or approved by the manufacturer can be used. Using other accessories may damage the device and cannot achieve the expected performance described in this manual.

1.4 Safety Symbols

The following table is provided for your identification of important symbols in labels on the device.

Symbol	Meaning
	Refer to instruction manual

Symbol	Meaning
	Caution
	Manufacturer
	This product is provided with a CE marking in accordance with the regulations stated in Regulation (EU) 2017/745.
	Serial Number
	Alternating current
	OFF (Power)
	ON (Power)
	Stand-by
	Authorized representative in the European community
	Type BF Applied Part
	Equipotentiality
	Fuse
	This symbol indicates that waste electrical and electronic equipment must not be disposed of as unsorted municipal waste and must be collected separately. Please contact an authorized representative of the manufacturer for information concerning the decommissioning of your equipment.
	Model number
	Country and date of manufacture, CHN is the country code of China.
	Medical device
	Unique device identifier
	Temperature limit

Symbol	Meaning
	Humidity limitation
	Atmospheric pressure limitation
	Stacking limit by number
	Fragile, handle with care
	Keep away from rain
	This way up

2 Overview

To ensure the performance of the device, the operator should be completely familiar with the operations and functions of the device.

2.1 Packing

Make sure that all the following items are in the packaging box of the device.

- Image processor
- Keyboard
- Power cable
- Light control cable
- Optical fiber cable
- White balance cap
- White balance cap holder

Others: See the Packing List in the packaging box.

2.2 Component Introduction

2.2.1 Front Panel

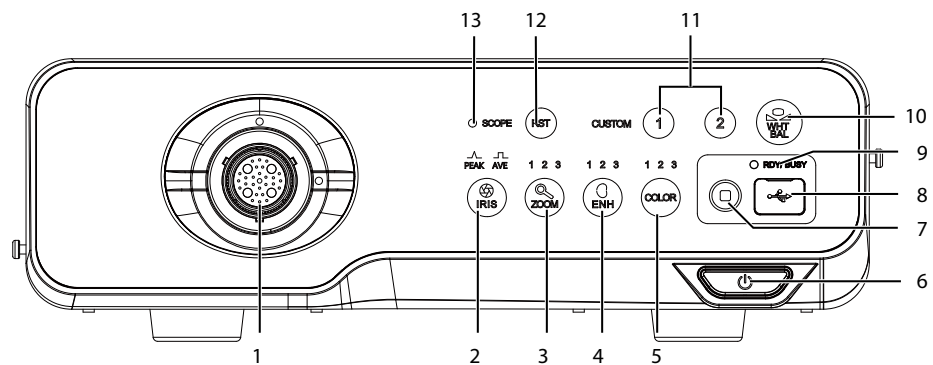

Figure 2-1 Front View

No.	Name	Description
1	Connector Port	Used for connecting the endoscope.

No.	Name	Description
2	Photometry Mode Button (IRIS)	<p>Press it to select peak, average or automatic photometry mode.</p> <ul style="list-style-type: none"> ● Average: Adjust image brightness according to the average brightness of the current image. The AVE indicator illuminates after the feature is enabled. ● Peak: Adjust image brightness according to the brightness of the highlight area of the current image. The PEAK indicator illuminates after the feature is enabled. ● Auto: Adjust the image brightness according to the average brightness and the highlight area of the current image. The PEAK and AVE indicators illuminate at the same time after the feature is enabled.
3	Zoom Level Adjustment Button (Zoom)	Press it to select magnification level 1, 2 or 3.
4	Structure/Edge Enhancement Button (ENH)	Press it to select level 1, 2 or 3 of structure enhancement or edge enhancement of the image.
5	Color Enhancement Button (COLOR)	Press it to select color enhancement level 1, 2 or 3.
6	On/Standby Button (⏻)	<ul style="list-style-type: none"> ● Power off status: Press it to power on the device and the indicator lights on. ● Power on status: Press it to switch the endoscope connection status; or, press it and hold for 3 seconds to power off the device on the main screen or the login screen, and the indicator lights off.
7	USB Storage Drive Stop Button (⏏)	Press it to stop the data transmission between the USB storage drive and the device.
8	USB Port (🔌)	Used for connecting to a USB storage drive.
9	USB Storage Drive Status Indicator (RDY/BUSY)	<p>Indicates the operating status of USB storage drive.</p> <ul style="list-style-type: none"> ● On: USB storage drive is connected. ● Flashing: Data is in transmission. ● Off: USB storage drive is disconnected.
10	White Balance Button (WHT BAL)	Press it to adjust white balance.
11	Custom Buttons (CUSTOM)	Press them to load the parameter settings of Custom 1 or Custom 2 .

No.	Name	Description
12	Restore Button (RST)	<ul style="list-style-type: none"> Automatic login: Restore the parameter settings of all public modes (Custom 1 to Custom 10) to default settings. Logging in through accounts: <ul style="list-style-type: none"> Administrator account: Restore the parameter settings of all public and personal modes to default settings. Ordinary account: Restore the parameter settings of public mode to the default settings of personal mode when public mode is loaded; or, restore the parameter settings of personal mode to the default settings of personal mode when personal mode is loaded.
13	Endoscope Connection Status Indicator (SCOPE)	<p>Indicates the connection status between the endoscope and the device.</p> <ul style="list-style-type: none"> On: Endoscope is connected. Off: Endoscope is disconnected.

2.2.2 Rear Panel

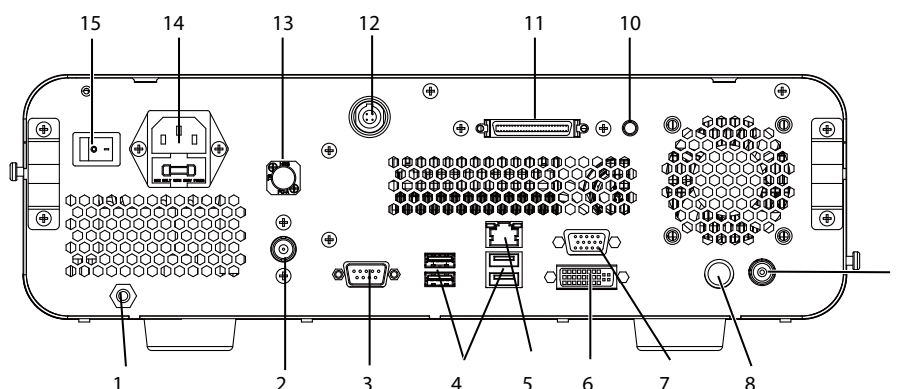

Figure 2-2 Rear View

No.	Name	Description
1	Equipotential Terminal (⚡)	Used for equipotential connection, balancing the protective earth potentials between the device and other electric equipment.
2	Video Output Port (SDI OUT)	Used for connecting a video device to acquire SDI signals.
3	Debugging Port (RS232)	Used for debugging the device only.
4	USB Port (USB)	Used for connecting a USB storage drive.
5	Network Port (ETHERNET)	Used for connecting to the network.
6	Video Output Port (DVI OUT)	Used for connecting a video device to acquire DVI signals.
7	Video Output Port (VGA OUT)	Used for connecting a video device to acquire VGA signals.
8	Video Output Port (S-VIDEO OUT)	Used for connecting a video device to acquire S-VIDEO signals.
9	Video Output Port (CVBS OUT)	Used for connecting a video device to acquire CVBS signals.
10	Print Port (PRINT CONTROL)	Used for connecting a video printer.

No.	Name	Description
11	Light Control Port (LIGHT CONTROL)	Used for connecting the light source.
12	Footswitch Port (FOOT SW)	Used for connecting the footswitch.
13	Optical Fiber Port	Used for connecting the light source.
14	Power Input Port	Used for connecting the power cable.
15	Main Power Switch (I/O)	Used for powering on/off the device.

2.2.3 Side Panel

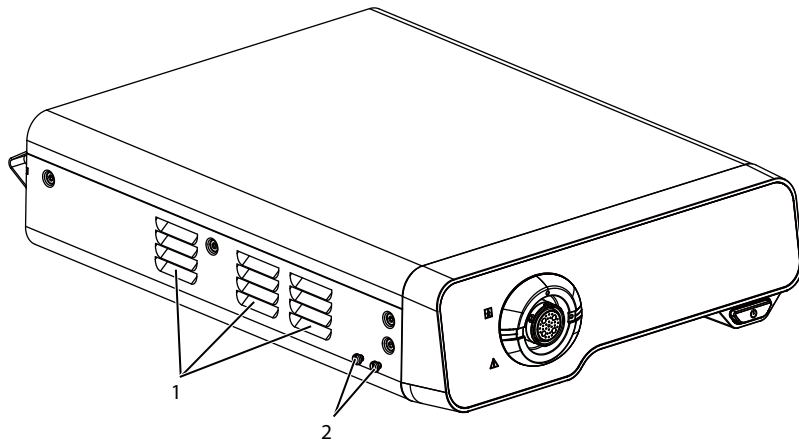

Figure 2-3 Left Side View

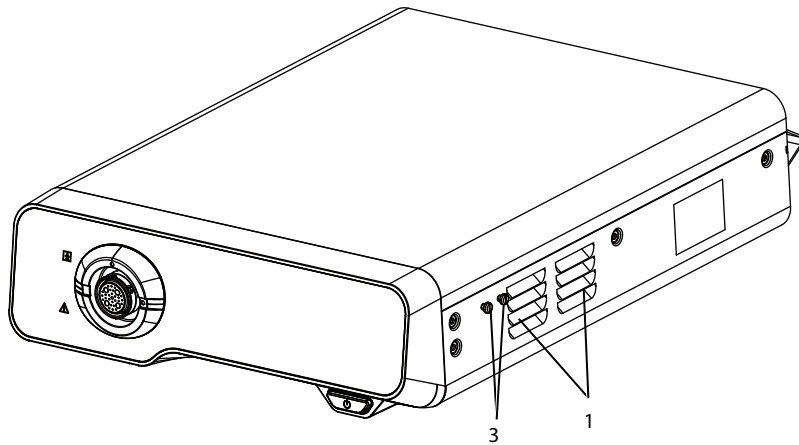

Figure 2-4 Right Side View

No.	Name	Description
1	Ventilation Ports	Used for dissipating internal heat of the device.
2	Screws for Endoscope Cable Holder	Used for hanging endoscope cable holder.
3	Screws for White Balance Cap Holder	Used for hanging white balance cap holder.

2.3 Keyboard

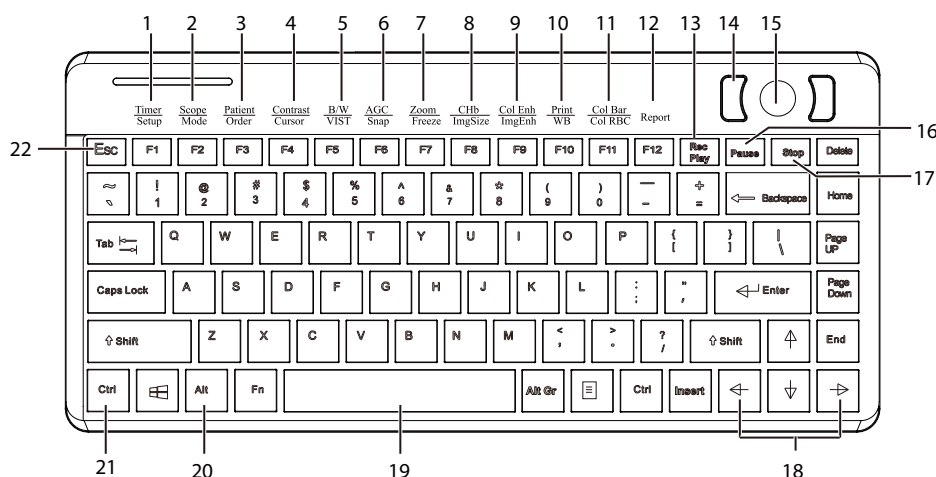

Figure 2-5 Keyboard

No.	Name	Description
1	F1: Timer/Setup	<ul style="list-style-type: none"> Press it to enter the System Settings menu. Press Alt + F1 to enable/disable the timer.
2	F2: Scope/Mode	<ul style="list-style-type: none"> Press it to enter the Mode Settings menu. Press Alt + F2 to display the details of the selected endoscope.
3	F3: Patient/Order	<ul style="list-style-type: none"> Press it to enter the Order List screen. Press Alt + F3 to enter the Patient List screen.
4	F4: Contrast/Cursor	<ul style="list-style-type: none"> Press it to display or hide the cursor. Press Alt + F4 to adjust the image contrast.
5	F5: VIST	Press it to select the illumination mode.
6	F6: AGC/Snap	<ul style="list-style-type: none"> Press it to save endoscopic images. Press Alt + F6 to enable or disable the automatic gain control.
7	F7: Zoom/Freeze	<ul style="list-style-type: none"> Press it to freeze the image and select it again to continue the examination. Press Alt + F7 to adjust the image magnification level (L1/L2/L3).
8	F8: CHb/ImgSize	<ul style="list-style-type: none"> Press it to switch the imaging area to full-screen mode and press it again to exit the full-screen mode. Press Alt + F8 to adjust the size of CHb pseudo-color image.
9	F9: Col Enh/ImgEnh	<ul style="list-style-type: none"> Press it to adjust the edge enhancement level or structure enhancement level (L1/L2/L3). Press Alt + F9 to adjust the color enhancement level (L1/L2/L3).
10	F10: Print/WB	<ul style="list-style-type: none"> Press it to adjust white balance automatically. Press Alt + F10 to start video printing.

No.	Name	Description
11	F11: Col Bar/Col RBC	<ul style="list-style-type: none"> ● Press it to adjust the image color tone (R/B/C). ● Press Alt + F11 repeatedly to select the color bar, gray scale image or endoscopic image.
12	F12: Report	<ul style="list-style-type: none"> ● Press it to enter the report edit screen. ● Press Alt + F12 to log out.
13	Rec/Play	Press it to record or play a video.
14	Confirm key	Press it to confirm the current operation.
15	Trackball	Use it to move the cursor.
16	Pause	Press it to pause recording or playing.
17	Stop	Press it to stop recording or playing.
18	Left/right arrow key	Press the left arrow key to display the previous image, and press the right arrow key to display the next image.
19	Space key	<ul style="list-style-type: none"> ● Press it and the Ctrl key simultaneously to the switch input language between English and Chinese. ● Press it to pause/start the timer, video playing or recording.
20	Alt	<ul style="list-style-type: none"> ● Press Alt + I to enter the trial information screen to view the device control. ● Press Alt+A to export data. ● Press Alt+U to upload data.
21	Ctrl	<ul style="list-style-type: none"> ● Press Ctrl+D to enter the Doctor List screen. ● Press Ctrl+S to enter the service screen. ● Press Ctrl+W to view the software version. ● Press Ctrl+A to select current page. ● Press Ctrl+H to view the key combination and corresponding function list.
22	Esc	Press it to exit the current screen.

2.4 Main Screen

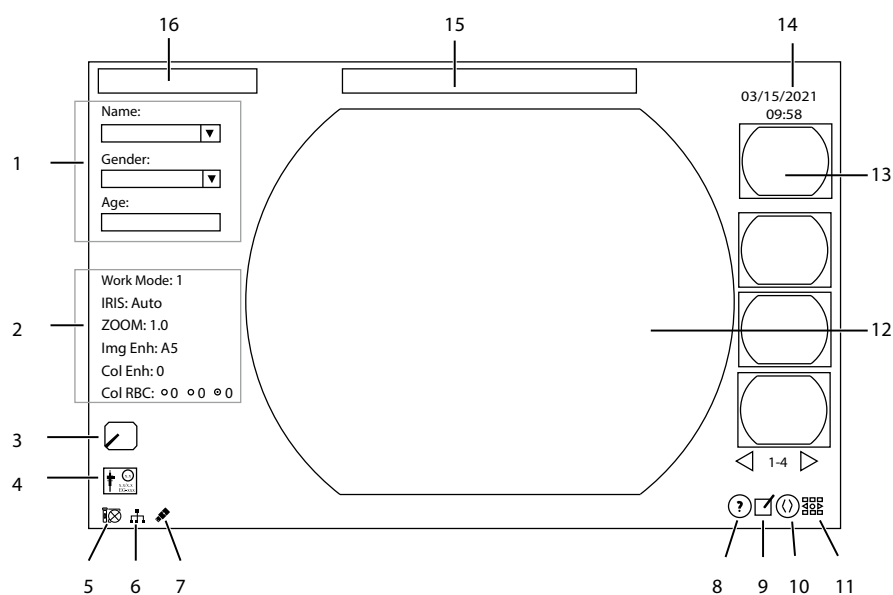

Figure 2-6 Main Screen

No.	Name	Description
1	-	Patient information. Click the area to edit or view more information.
2	-	Image parameters.
3		Biopsy indication. Click it to view the endoscope information.
4		Endoscope information. Click it to view the endoscope information.
5		Light control cable is disconnected.
6		Network is connected.
7		USB storage drive is connected.
8		Click it to view the key combination and corresponding function list. Click the functions to enter the corresponding screens.
9		Click it to enter the report edit screen.
10		Click it to switch screen.
11		Click it to display or hide the information outside the endoscopic image area.
12	-	Endoscopic video area
13	-	Thumbnail
14	-	System time
15	-	Hospital name
16	-	Manufacturer Logo

This page is intentionally left blank.

3 Preparations

Preparations are necessary before using the device which include device installation, connection and inspection.



WARNING Read through this chapter carefully before using the device to ensure that installation and connection are correct. Otherwise, it may cause damage to the device or personal injury.



- Power off the device and all peripherals before system connection. Otherwise, it may result in damage to the device and data loss.
- Only the cables provided by the manufacturer can be used for connection. Otherwise, it may result in damage or malfunction.
- Do not block the ventilation ports of the device. Place the device in a location with adequate ventilation. Otherwise, the device may be damaged.
- Do not cover this device with any object. Otherwise, it may damage the device.

3.1 Placing the Device

Lock the foot brakes of trolley (sold separately), place the light source on the trolley, and then place the device on the light source, as shown in Figure 3-1. It is recommended that four anti-slip mats be pasted under the four feet of the device to avoid accidental slide of the device.

NOTE:

- *Ensure that the device is placed on the light source steadily.*
- *Read the trolley installation manual for details.*

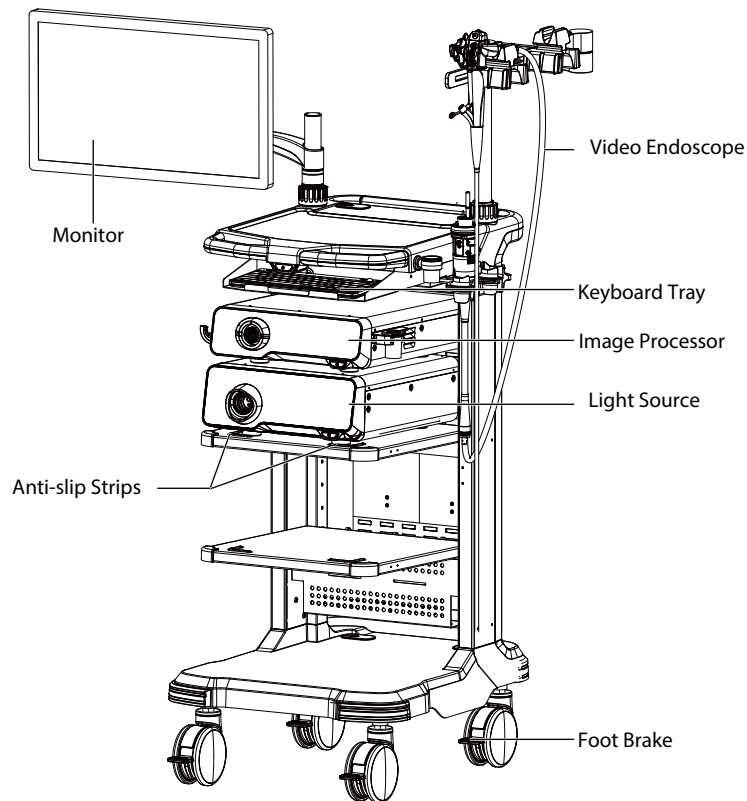

Figure 3-1 Placing the Device

3.2 Installing the White Balance Cap Holder

Perform following steps.

1. Align notch A or B on the white balance cap holder with the two screws on the right side of the device. Push the holder towards the rear side of the device until it stops, as shown in Figure 3-2.

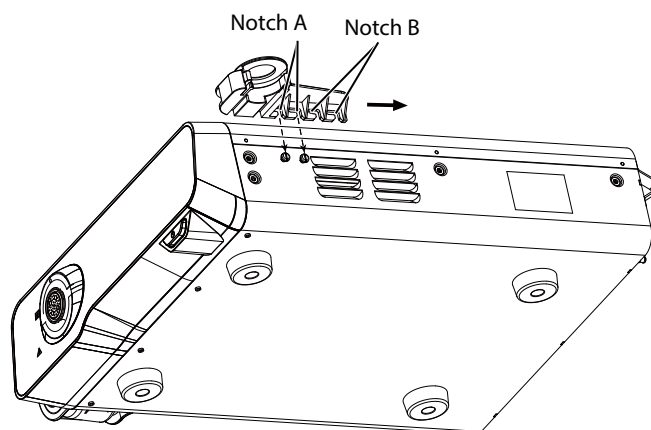

Figure 3-2 Installing the White Balance Cap Holder

2. Put the white balance cap into the holder. Align the head of the cap with the opening of the holder and insert the cap into the holder until it is in position, as shown in Figure 3-3.

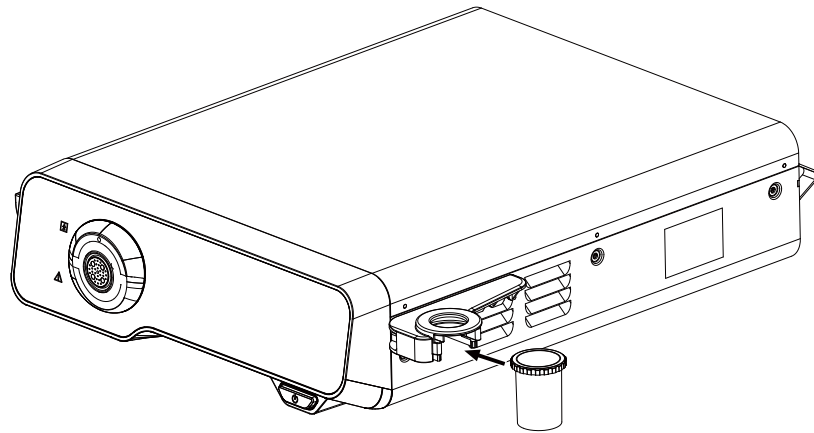

Figure 3-3 Installing the White Balance Cap

NOTE:

Only the white balance cap is allowed to be hung onto the holder.

3.3 Connecting the System

Connect the endoscope system, as shown in Figure 3-4.

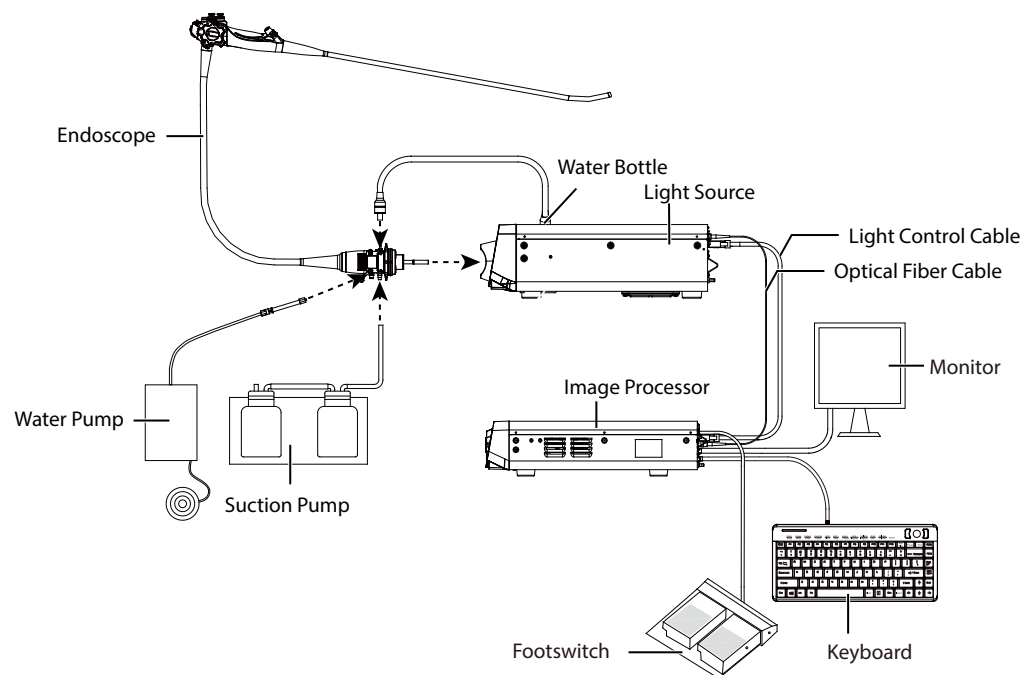

Figure 3-4 Connecting the Endoscope System

3.3.1 Connecting the Light Source

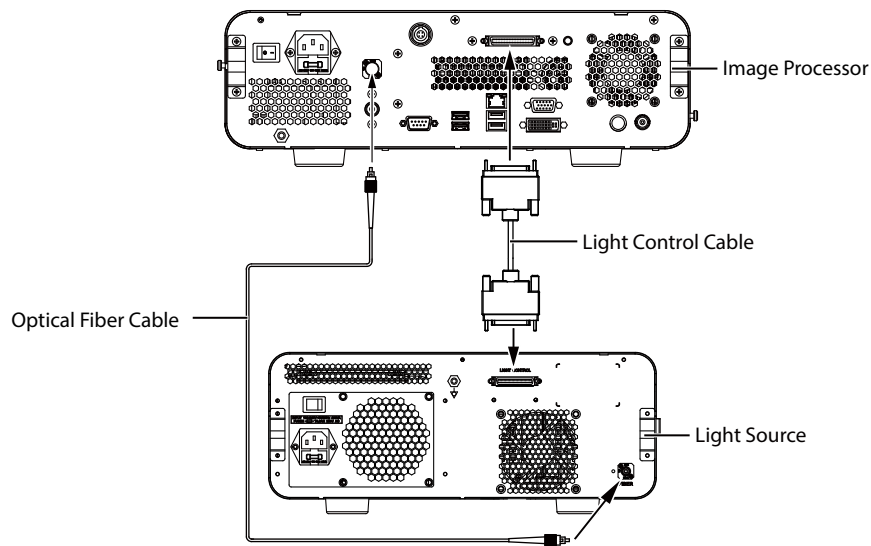

Figure 3-5 Connecting the Light Source

Perform following steps.

1. Connect the light control cable securely to the light control port of the device and the light control port of the light source.
2. Connect the optical fiber cable securely to the optical fiber port of the device and the light control port of the light source.

3.3.2 Connecting the Monitor

Before connecting monitor, select an appropriate video cable. Connect the two ends of the video cable to the device and monitor respectively.

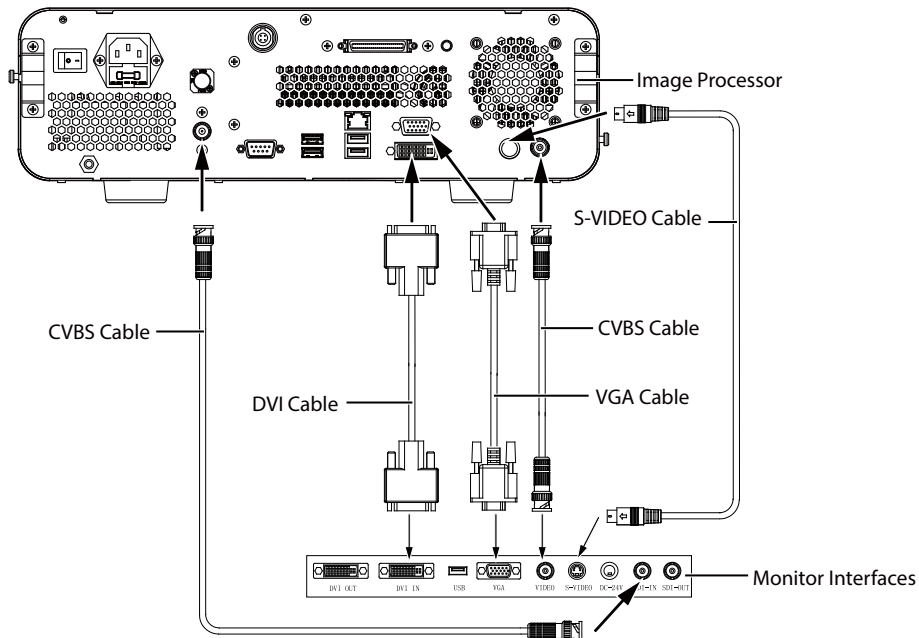

Figure 3-6 Connecting the Monitor

■ **Video signal and format**

- DVI (high definition)

- VGA (high definition)
- SDI (high definition)
- CVBS (standard definition)
- S-Video (standard definition)

The standard-definition video output interfaces of the device support PAL and NTSC standards.

■ Video signal output

The high-definition and the standard-definition interfaces of the device can output video signals simultaneously.

3.3.3 Connecting the Keyboard



Do not pour any fluid onto the keyboard. Otherwise, it may cause damage to the keyboard or malfunction.

NOTE:

Ensure that the keyboard is placed on the keyboard tray of the trolley properly before connection.

Connect the keyboard to the device, as shown in Figure 3-7.

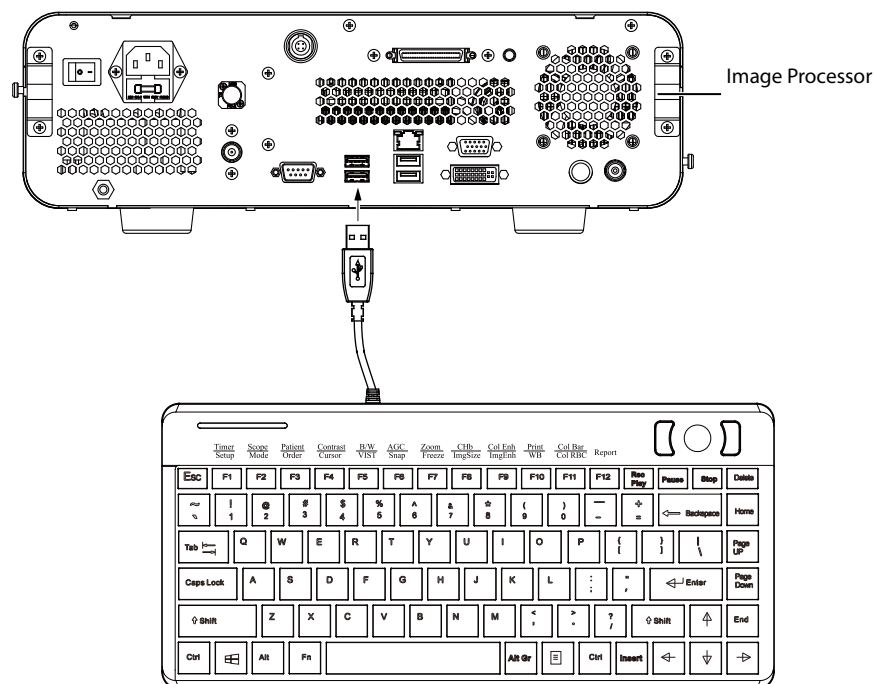

Figure 3-7 Connecting the Keyboard

3.3.4 Connecting the Footswitch



- Use the footswitch provided by the manufacturer only. Otherwise, it may result in damage to the device or the footswitch.
- Do not place the footswitch on the device.

Connect the footswitch to **FOOT SW** port of the device, as shown in Figure 3-8.

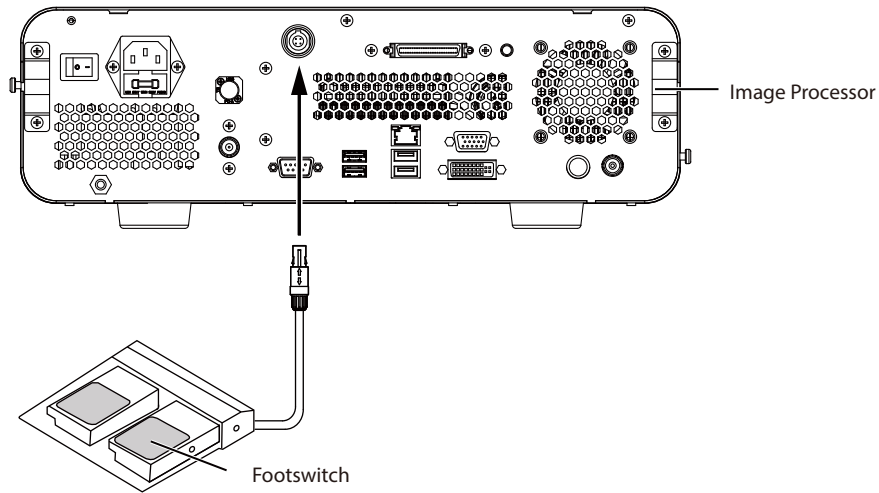

Figure 3-8 Connecting the Footswitch

Functions of left and right pedals can be preset through the device.

3.3.5 Connecting the Video Printer

■ **To use the CVBS/S-VIDEO cable and the video printer control cable**

Perform the following steps.

1. Connect the video printer to the device by using a CVBS/S-VIDEO cable and a print control cable, as shown in Figure 3-9.

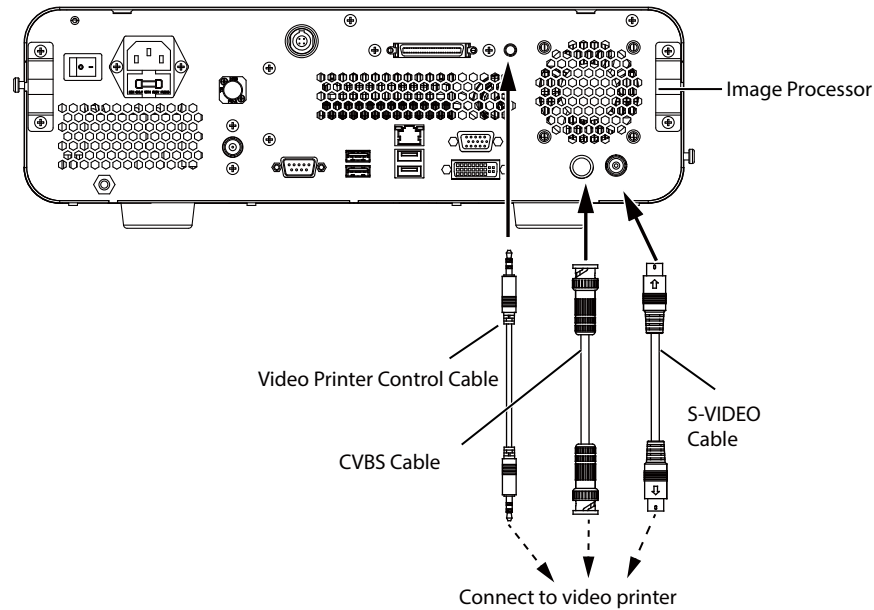

Figure 3-9 Connecting the Video Printer 1

2. Press the **F1** key on the keyboard to enter the **System Settings** screen, select **Video Parameters** screen and then set video printer as **GPIO + Video**. Click **Save** on the **Video Parameters** screen to save the settings.
3. Enter the main screen and press **Alt+F10** on the keyboard to print the video.

■ **To use the USB cable**

Perform the following steps.

1. Connect the video printer to the device by using a USB cable, as shown in Figure 3-10.

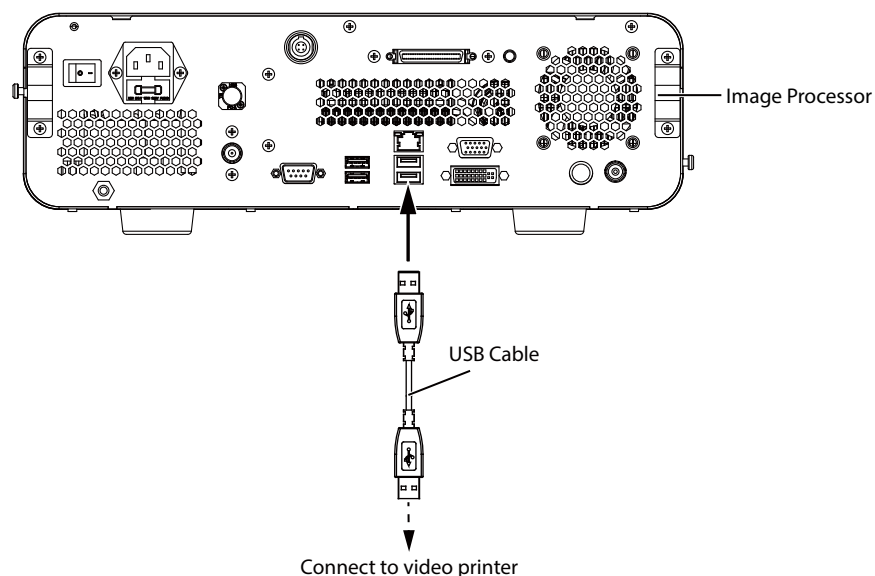

Figure 3-10 Connecting the Video Printer 2

2. Press the **F1** key on the keyboard to enter the **System Settings** menu, select the **Video Parameters** screen and then set **Video Printer** as **USB**.
3. Click **Select** to enter the **Driver Type** screen. Select the corresponding drive according to the USB printer model and click **OK**. Click **Save** on the **Video Parameters** screen to install the drive.
If the installation is failed, click **Reinstall** to reinstall the current drive.
4. After the drive is installed, enter the main screen and press **Alt+F10** on the keyboard to print the video.

3.3.6 Connecting the Report Printer

■ To use the network printer

Perform the following steps.

1. Connect the network ports of the printer and the device by using network cables respectively. Or, connect the printer and the device to the same local area network.
2. Press the **F1** key on the keyboard to enter the **System Settings** screen, and set the default printer as **Network Printer** on the **Contextual Mode** screen.
3. Click **Search** to search for the network printer IP, select the corresponding IP, and then click **OK** to set the network printer IP.
4. Click **Select** to enter the **Drive Type** screen, select the corresponding drive type according to the printer mode, and click **OK**. Click **Save** on the **Contextual Mode** screen to install the printer.
If the installation is failed, click **Reinstall** to reinstall the current drive.
5. After the drive is installed, enter the **Report Edit** screen and click **Print (F9)** to print the report. Or click **Preview (F8)**-> **F1** on the **Report Edit** screen to print the report.

■ To use the USB printer

Perform the following steps.

1. Connect the device and the report printer by using the USB cable.
2. Press the **F1** key on the keyboard to enter the **System Settings** screen, and set the default printer as **USB Printer** on the **Contextual Mode** screen.

3. Click **Select** to enter the **Driver Type** screen, select the corresponding drive according to the printer model, and click **OK**. Click **Save** on the **Contextual Mode** screen to install the printer.
If the installation is failed, click **Reinstall** to reinstall the current drive.
4. After the drive is installed, enter the **Report Edit** screen and click **Print (F9)** to print the report, or click **Preview (F8)-> F1** on the **Report Edit** screen to print the report.

3.3.7 Connecting to the Network

Connect the device to the network by using a network cable.

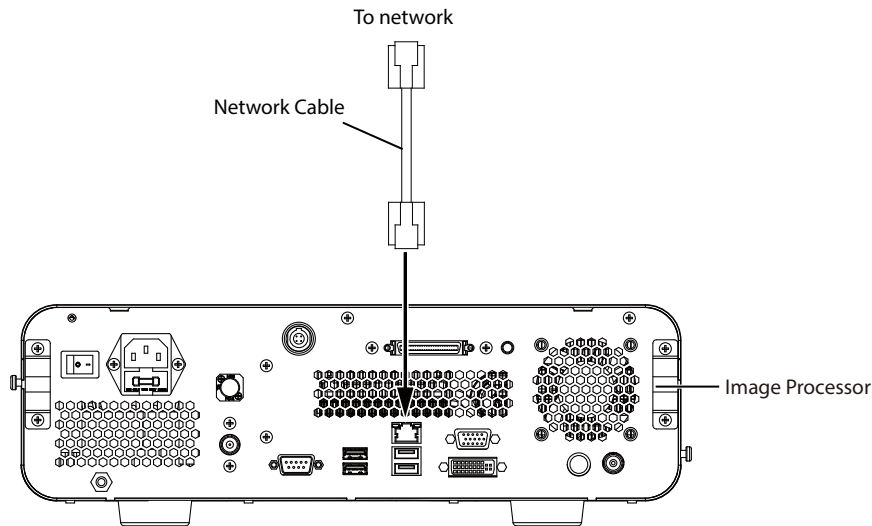

3.3.8 Connecting the Power Supply



WARNING Do not excessively bend, pull or twist power cable. Otherwise it may cause an electric shock or fire.



CAUTION Ensure that power cable is connected firmly.

Perform the following steps to connect the power supply.

1. Connect the equipotential terminal at the rear panel of the device with protective earth or with the equipotential terminals of other devices by using a grounding cable.
2. Connect the power cable to the power input on the rear panel of the device and an electric outlet.

3.4 Inspecting the Device

3.4.1 Inspecting System Connection

Ensure that all peripherals are connected to the device properly.

3.4.2 Inspecting Power Supply

Perform the following steps.

1. Set the main power switch on the rear panel to the **I** position.
2. Press the **⏻** button on the front panel to power on the device.

3.4.3 Inspecting Illumination

Power on the light source, and ensure that the light is emitted from the distal end of the endoscope. Refer to the relevant light source user manual for details.

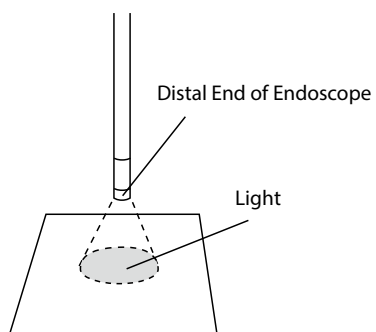

3.4.4 Inspecting Image

Perform the following steps to inspect image display.

1. After the system initialization, the patient examination screen (the main screen) is displayed, as shown in Figure 2-6.
2. Observe an object (such as your palm) and ensure that the image displayed is normal.

3.4.5 Inspecting the Freezing Feature

Press the **F7** key on the keyboard to freeze an image in the real-time mode, and press **F7** again to restore the real-time mode.

This page is intentionally left blank.

4 Operations

The operator of this device should be a physician or the medical personnel who operates under the supervision of a physician and should have received sufficient training in clinical endoscopic technique. This manual, therefore, does not explain or discuss clinical endoscopic procedures. It only describes basic operations and precautions related to the operation of this device.



WARNING Stop the examination immediately and perform the following operations, if the device appears abnormal.

- If the image disappears or is frozen and cannot be restored, press the power button on the front panel, and disconnect the endoscope. Then press the power button again and connect the endoscope. If the problem still exists, reboot the device. If rebooting the device cannot solve the problem, stop using the device immediately, power off the device and the light source, and withdraw the endoscope gently from the patient's body as described in the endoscope user manual.
- If any other abnormality appears or is suspected, stop the examination immediately, and withdraw the endoscope gently from the patient's body as described in the endoscope user manual. For details, refer to Section 7.4 Troubleshooting.



CAUTION Do not operate the device around strong electromagnetic field. Otherwise, the image on the screen may disappear.

4.1 Powering on the Device

Perform the following step.

1. Set the main power switch on the rear panel to the **I** position.
2. Press the  button to power on the device and the power indicator turns on.
3. Power on all the peripherals connected to the device, such as the monitor and the light source. For detailed operations, refer to the relevant user manual of the peripherals.

4.2 Entering the System

NOTE:

The system at most supports 100 accounts.

The system supports two login modes: account login and automatic login. To ensure the safe management of patient information, the account login mode is recommended.

The account login mode assigns two account levels: admin account and common account.

4.2.1 Selecting the Login Mode

The login mode can be switched only when the system is logged into through automatic login mode or with the admin account.

Perform the following steps.

1. Press **Ctrl+D** on the keyboard to display the **Doctor List** screen.

Doctor List

Account Login(admin) Automatic Login

	Job ID	Name	Title	Account
1	Admin		Admin	Admin

Total:1  1 / 1

Figure 4-1 Doctor List Screen

2. Select **Account Login** or **Automatic Login**.
3. Click **Exit** to switch the login mode.

4.2.2 Managing Accounts

An ordinary user account can be added, edited or deleted by an administrator.

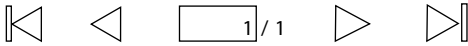
■ To add an account

Perform the following steps.

1. Press **Ctrl+D** on the keyboard to display the **Doctor List** screen.
2. Click **Add** to enter the **Add** screen.

Add	
Doctor Info _____	Account Info _____
* Job ID: <input type="text"/>	Account: <input type="text"/>
* Name: <input type="text"/>	Password: <input type="text"/>
Title: <input type="text" value="Resident physician"/> ▼	Confirm: <input type="text"/>
(*: Required Filed.)	
<input type="button" value="Private Mode"/>	
<input type="button" value="Save"/>	<input type="button" value="Exit"/>

Figure 4-2 Add Screen

3. Enter user information and click **Save** to save the information.
4. Click **Exit** to back to the **Doctor List** screen.

■ **To edit account information**

Perform the following steps.

1. Press **Ctrl+D** on the keyboard to display the **Doctor List** screen.
2. Select a desired account and click **Edit** to enter the **Edit** screen.

Edit	
Doctor Info _____	Account Info _____
* Job ID: <input type="text"/>	Account: <input type="text"/>
* Name: <input type="text"/>	Password: <input type="text"/>
Title: <input type="text" value="Resident physician"/> ▼	Confirm: <input type="text"/>
(*: Required Filed.)	
<input type="button" value="Private Mode"/>	
<input type="button" value="Save"/>	<input type="button" value="Exit"/>

Figure 4-3 Edit Screen

3. Enter user information and click **Save** to save the information.
4. Click **Exit** to return to the **Doctor List** screen.

■ To delete an account

Perform the following steps.

1. Press **Ctrl+D** on the keyboard to display the **Doctor List** screen.
2. Select an account, enter the administrator password in the pop-up dialog box and click **OK** to delete the account.

■ To switch login account

Perform the following steps.

1. Press **Alt + F12** on the keyboard, and click **OK** in the pop-up dialog to log off the current account and enter the login screen.
2. Enter a new account and password to log into the system.

4.3 Entering Patient Information

The system supports two ways to enter patient information: entering patient information in advance, and entering patient information during examination.

4.3.1 Entry in Advance

It is recommended to create a work order for each patient before exam to manage the patient information.

Press the **F3** key on the keyboard to display the **Order List** screen.

Order List

All

F7 F8 F10 F11

	Name	Gender	Age	ID	Applicant	Pre-exam Date	Status
1	Totti	F	23	2231	xxx	11/03/2016	Not examined
2	Jerry	F	17	2232	xxx	13/03/2016	Not examined
3	Lily	M	26	2233	xxx	16/03/2016	Not examined

Total: 3

Navigation: / 1

Buttons: Exam(F1) Add(F2) Edit(F3) Select All(F5) Download(F6) Del(Delete) Exit(Esc)

Figure 4-4 Order List Screen

■ To set work order

Perform the following steps.

1. Click the icon or press the **F10** key on the keyboard to enter the **Settings** menu.

Settings	
Order Display	
<input checked="" type="checkbox"/> DoB	<input checked="" type="checkbox"/> Tel.
<input checked="" type="checkbox"/> Custom Field1	<input type="checkbox"/> Custom Field2
List	
<input type="checkbox"/> Age	<input checked="" type="checkbox"/> ID
<input checked="" type="checkbox"/> Applicant	<input type="checkbox"/> Application Date
<input type="checkbox"/> Bed No.	<input type="checkbox"/> Accession Number
Status:	All
Pre-exam Date:	
<input type="radio"/> All	<input type="radio"/> 03/15/2021 -- 03/15/2021
Worklist Query	
<input checked="" type="checkbox"/> Name:	<input checked="" type="checkbox"/> Examination Equipment: Endoscopy
<input type="checkbox"/> ID:	<input type="checkbox"/> Accession Number:
<input checked="" type="checkbox"/> Pre-exam Date:	<input type="radio"/> Today
	<input type="radio"/> 03/15/2021 -- 03/15/2021
<input type="button" value="Save"/> <input type="button" value="Exit"/>	

Figure 4-5 Setting the Work Order

2. Set the following:
 - Order Display: Tick the information that need to be displayed on the work order.
 - List: Tick the information that need to be displayed on the work order.
 - Worklist Query: Tick to download the filter condition of the Worklist.

NOTE:

*If you tick **Custom Field** and enter an item in the corresponding text box, the item will be displayed in the work order.*

3. Click **Save** to save the current settings.

■ **To create work order**

Perform the following steps.

1. Click **Add (F2)** to display the **Order List** menu.

The screenshot shows a form titled "Order" with two main sections: "Patient Info" and "Exam Info".

Patient Info

- ID: [Text Field] [Dropdown Arrow] [Database Icon]
- *Name: [Text Field] [Dropdown Arrow]
- Gender: [Text Field] [Dropdown Arrow]
- Age: [Text Field]

Exam Info

- Exam Item: [Text Field] [Dropdown Arrow]
- Pre-exam Date: [Date Field: 03/15/2021] [Dropdown Arrow]
- Applicant: [Text Field] [Dropdown Arrow] [Database Icon]
- Application Date: [Date Field: 03/15/2021] [Dropdown Arrow]
- Status: Not examined

(*: Required Filed.)

Buttons: Save, Exam, Exit

Figure 4-6 Work Order

2. Enter **Patient Info** and **Exam Info**.
3. Click **Save** to save the work order into the order list.

■ **To edit work order information**

The current work order can be edited in the work order list.

Perform the following steps.

1. Select a work order on the **Order List** screen, and click **Edit (F3)** to enter the editing screen.
2. Edit the information of the selected work order.
3. Click **Save** to save the information.

■ **To download work orders**

The device is configured with the DICOM module, and you can download patient information from the DICOM server. For details, refer to 6 DICOM.

■ **To retrieve work orders**

Retrieve the work orders on the main screen.

Perform the following steps.

1. Select the type of the work orders to be displayed from the drop-down list on the **Order List** screen.
2. Select the desired work order, and click **Exam (F1)** to retrieve the work order information.
The work order information is then displayed on the main screen.

■ **To delete a work order**

NOTE:

The deleted work order cannot be recovered. Perform the deletion with caution.

Perform the following steps.

1. Select the type of the work orders to be displayed from the drop-down list on the **Order List** screen.

2. Select the desired work orders.
3. Click **Del (Delete)** to delete the selected work orders.

■ To search for work orders

Perform the following steps.

1. Click  (**F8**) to enter the **Search** screen.

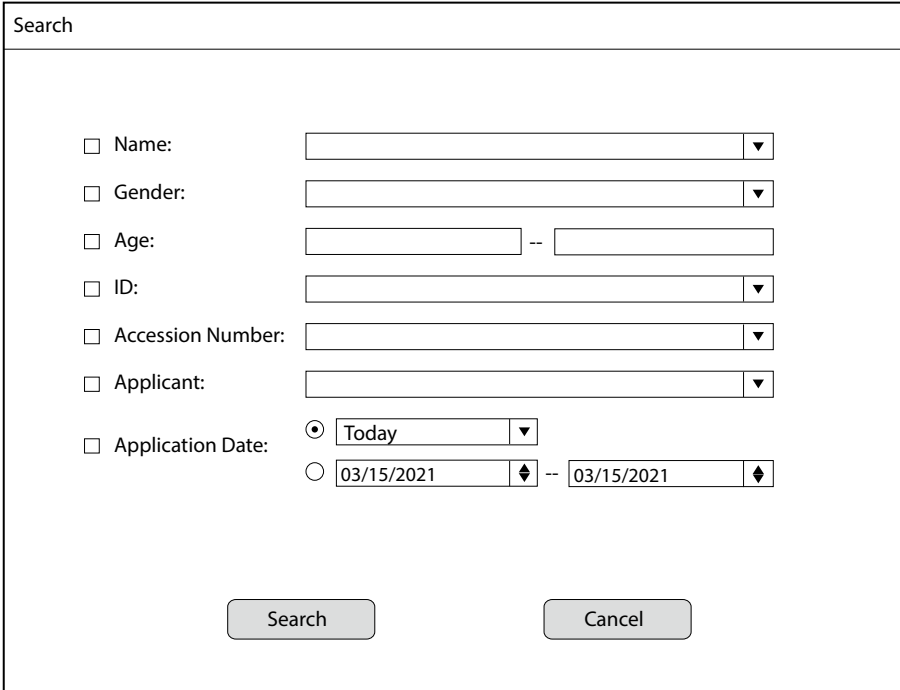

The screenshot shows a 'Search' dialog box with the following fields:

- Name: [text input]
- Gender: [dropdown]
- Age: [text input] -- [text input]
- ID: [dropdown]
- Accession Number: [dropdown]
- Applicant: [dropdown]
- Application Date: [Today] [dropdown]
- Application Date: [03/15/2021] [calendar icon] -- [03/15/2021] [calendar icon]

Buttons: Search, Cancel

Figure 4-7 Work Order Search Screen

2. Tick and enter the search criteria, and then click **Search**. The search results are displayed on the **Order List** screen.

4.3.2 Entry During Examination

You can enter patient name, gender, age, date of birth and ID, and doctor name on the patient information area when performing an examination.

4.4 Setting the Work Mode

Users can set a private mode according to actual needs. The system provides 10 public modes (Custom 1-Custom 10) for users to select, and the parameters of each public mode can be set only when the system is logged into through automatic login mode or the admin account.

Perform the following steps.

1. Press the **F2** key on the keyboard to display the **Mode Settings** menu.

Figure 4-8 Mode Settings Screen

2. Select a user mode from the drop-down list of mode selection on the menu.
3. Set parameters on the menu. Click to display more parameters on the screen.
The following table describes the settings of these parameters.

Area	Item	Description
Enh	Img Enh	Set the values corresponding to the levels of structure enhancement or edge enhancement (L1/L2/L3).
	Col Enh	Set the values corresponding to the color enhancement levels (L1/L2/L3).
	Type	Select image enhancement type. <ul style="list-style-type: none"> ● Edge: Enhance edge sharpness of image. ● Struct A: Enhance contrast of image details. ● Struct B: Enhance resolution of image details.

Area	Item	Description
Color	R	Set the value of R (red).
	B	Set the value of B (blue).
	C	Set the value of C (chroma).
Zoom	L1/L2/L3	Set the values corresponding to the image magnification levels (L1/L2/L3).
Remote Buttons (0/1/2/3), Left /right pedal of footswitch	Freeze	Click it to enable/disable the image-freezing function.
	Zoom	Click it to select the image magnification levels (L1/L2/L3).
	VIST	Click it to select the illumination mode.
	IRIS	Click it to select photometry modes (Ave, Peak and Auto).
	Img Enh	Click it to switch among the levels of edge enhancement or structure enhancement (L1/L2/L3) .
	Col Enh	Click it to switch among the three levels of color enhancement (L1/L2/L3).
	CHb	Click it to adjust the size of CHb pseudo-color image.
	Transparent	Click it to enable/disable transillumination feature.
	Contrast	Click it to select the image contrast levels.
	AGC	Click it to enable/disable automatic gain feature.
	ImgSize	Click it to enter/exit full-screen mode.
	Snap	Click it to save the current endoscopic image..
	Video Print	Click it to print the endoscopic image.
	Record	Click it to start/stop recording.
	Timer	Click it to start/pause time keeping.
	PBP	After the endoscopic image is frozen, click it to enable/disable the picture by picture (PBP) feature.
Content display	Switch the contents displayed on the main screen.	
Fast Export	Select it on the main screen to directly export the image or video saved currently.	
Fast Upload	Select it on the main screen to upload images and the report saved currently to the DICOM server.	
Other	IRIS	Set the photometry mode.
	Contrast	Set the image contrast.
	Save Automatically	Tick it to save the value of IRIS and levels of ZOOM, ENH and COLOR in the current mode during shutdown or logout.

4. Perform the following operations by clicking the corresponding keys.
 - **Save:** Click **Save** to save the current settings.
 - **Load:** Click **Load** to save the current settings and load them to the main screen.

- **Default:** Click **Default** to restore factory settings.
- **Exit:** Click **Exit** to exit the **Mode Settings** menu and return to the main screen.

4.5 Replacing the Endoscope

The device supports hot plugging of the endoscope. The endoscope can be replaced when the device is in use.

NOTE:

It takes several seconds to initialize endoscope information after replacement.

4.6 Adjusting the Monitor

The color bar can be demonstrated to adjust the color display of the monitor.

Perform the following steps.

1. Press **Alt+F11** on the keyboard to display the color bar.
2. Press **Alt+F11** on the keyboard again to display the gray image.
3. Adjust the color display as described in the monitor user manual.
4. Press the **Esc** key on the keyboard to exit.

4.7 Optimizing the Image

4.7.1 Adjusting the White Balance

Adjust image white balance to produce an image with accurate colors.



- **WARNING** Ensure that the distal end of endoscope and white balance cap are clean before adjusting white balance. Otherwise cross-contamination may occur.
- Adjust the white balance of image according to observing object. Improper adjustment may lead to inaccurate observation or wrong diagnosis.

NOTE:

- Power on light source before adjustment and ensure that the light emitted from the distal end of endoscope is not interfered by other light. Otherwise, white balance cannot be adjusted correctly.
- Adjust white balance again after the replacement of the light source or the main lamp.

Perform the following steps.

1. Turn on the lamp of the light source, ensuring that light emits from the distal end of endoscope.
2. Press the **AUTO** button on the front panel of the light source to enable the automatic mode of adjustment.
3. Wipe the inner of the white balance cap by using a lint-free soft cloth dampened with 75% ethyl alcohol.
4. Put the distal end inside the white balance cap to avoid reflection on image.

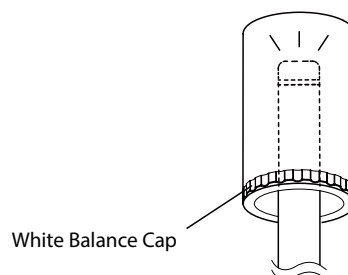

5. Press and hold the **WHT BAL** button on the device to enable white balance feature. After the white balance is adjusted, a prompt will be displayed on the screen.

4.7.2 Magnification

Press the **ZOOM** button on the front panel to adjust the magnification level. The indicator corresponding to the selected magnification level will be illuminated.

4.7.3 Color Enhancement

Press the **COLOR** button on the front panel to adjust color enhancement level. The indicator corresponding to the selected color enhancement level will be illuminated.

The higher the color enhancement level is, the sharper the image color is.

4.7.4 Red-blue Pseudo-color Image Display

Press **Alt+F8** on the keyboard to set the display area size of the red-blue pseudo-color image.

The higher the hemoglobin concentration is, the darker the red area of the pseudo-color images is.

4.7.5 Image Enhancement

Press the **ENH** button on the front panel to adjust the edge enhancement level or structure enhancement level. The indicator corresponding to the selected level of edge enhancement or structure enhancement will be illuminated.

The image enhancement includes edge enhancement and structure enhancement. The structure enhancement includes two modes: Structure A and Structure B.

4.7.6 Contrast

Press **Alt+F4** on the keyboard to switch the contrast among the medium, high and low modes. The relevant information will be displayed on the screen.

The contrast indicates the different colors and brightness of the image. The higher the contrast is, the richer the colors and the greater the difference between the light and shade are.

4.7.7 Switching the Illumination Mode

Press the **F5** key on the keyboard to select the illumination mode and the information of the corresponding illumination modes is displayed on the screen.

Different illumination modes can be adopted different observation distances and their effects differs. You can select the corresponding illumination mode based on your demands.

- **White light mode (WL):** This mode features high rendering index and high brightness, which is applicable to the normal examination.
- **Enhanced white light mode (EWL):** This mode can highlight the contour of the mucosal vessels with a color tone similar to the white light mode, which is applicable to the normal examination and lesion identification in the middle and far fields.
- **Spectral focused imaging (SFI):** This mode can highlight the contour of the superficial and middle mucosal vessels, which is applicable to the lesion identification and early cancer screening in the middle and far fields.
- **Versatile intelligent staining technology (VIST):** This mode can highlight the contour of the superficial mucosal vessels and mucosal surface micro-structure, which is applicable to the accurate diagnosis of early cancer in the middle and near fields.

4.8 Managing Images and Videos

Endoscopic images and videos are saved in the system by default. If necessary, you can export the saved images and videos to a storage device like a USB drive for review and management.

4.8.1 Saving Images and Videos

■ To save images

Enter the main screen and press the **F6** key on the keyboard to save the current image.

The thumbnail of the saved image is displayed on the main screen.

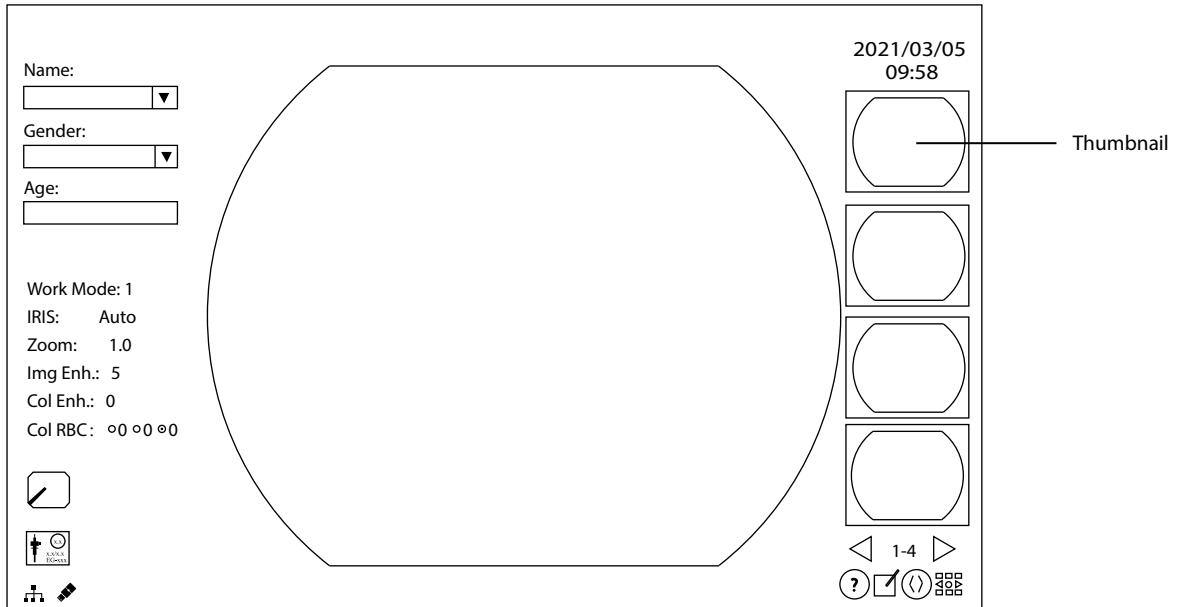

Figure 4-9 Saving Images

■ To save videos

Perform the following steps.

1. Enter the main screen.
2. Press the **Rec/Play** key on the keyboard to start recording.
3. Press the **Stop** key on the keyboard to stop recording and save a video.

The thumbnail of the saved video is displayed on the main screen.

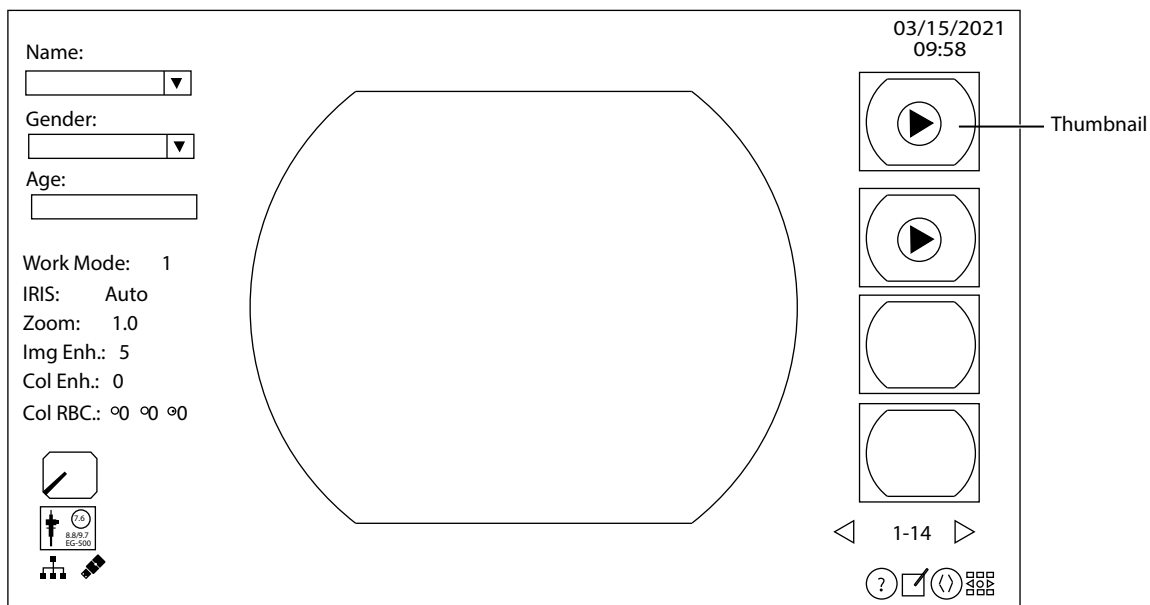

Figure 4-10 Saving Videos

4.8.2 Viewing Images and Videos

NOTE:

Images/videos can be reviewed by viewing patient record.

- **To view images**

Select a thumbnail by using the trackball, and then press the confirm key to view the image. Press the up/down key on the keyboard to select the images.

- **To view videos**

Perform the following steps.

1. Select a video thumbnail on the right of the main screen.
2. Click the confirm key twice, or press the confirm key and then press the **Enter** or **Rec/Play** key on the keyboard to view the video.

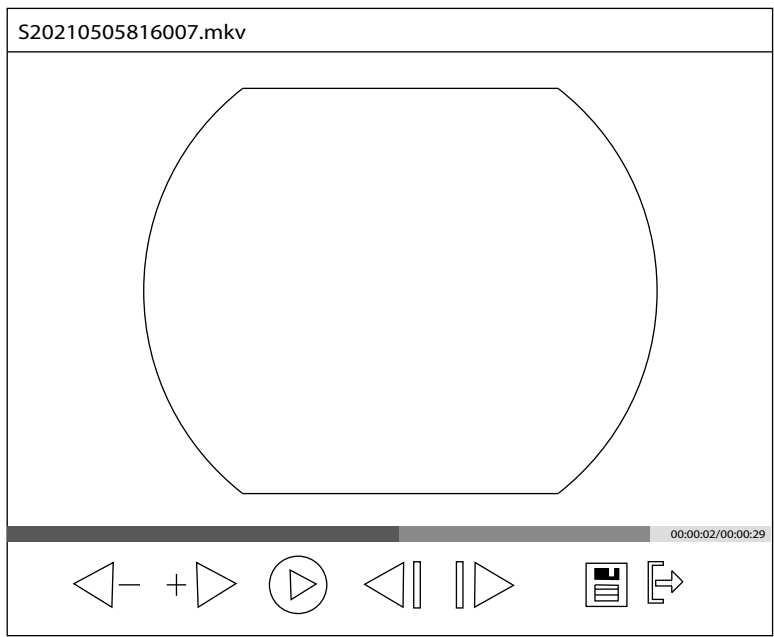

Figure 4-11 Media Player

Operate the media player by using the trackball and the confirm key.

Button	Function
	Click it to start a video.
	Click it to pause a video.
	Click it to switch video playback speed.
	Click it to switch video playback speed.
	Click it to view the previous frame from a paused video.
	Click it to view the next frame from a paused video.
	Click it to save the desired image from a paused video.
	Click it to exit the media player.

4.9 Managing Patient Record List

Patient records can be stored, reviewed and retrieved. They can also be exported to a USB drive or DICOM server for backup.

Press **Alt+F3** on the keyboard to display the **Patient List** screen.

Patient List							
All							F8 F10 F11
	Name	ID	Exam Date	Doctor	Endoscope	Status	Exam No.
1	Totti	2235	04/05/2016	David	xx-xxx		201604050002C
2	Jerry	2236	04/05/2016	Edison	xx-xxx	---	201604050001G

Total: 2

Navigation: < << 1/1 >> >

Buttons: Report(F1) View(F2) Cancel Exam(F3) Select All(F5) Export(F6) DICOM Upload(F7) Del(Delete) Exit(Esc)

Figure 4-12 Patient List Screen

In the status column on the **Patient List** screen:

Status	Description
Eg	Indicates the exam is conducting.
---	Indicates that exam is completed.
Blank	Indicates that conclusion has been reached.
PX	Indicates the number of times the report is printed. X stands for the number of times that the report is printed.
UX	Indicates the number of times the report is uploaded. X stands for the number of times that the report is uploaded.
PX UX	Indicates the number of times the report is printed and uploaded. UX stands for the number of times that the report is uploaded.
C	Indicates the exam is canceled.

NOTE:

X indicates the number of times. When the number of times the report is printed or uploaded exceeds 9, + is displayed directly.

■ **To search for patient records**

Perform the following steps.

1. On the **Patient List** screen, click  (**F8**) to enter the **Search** screen.

The screenshot shows a search interface with the following elements:

- Name: [Text Input]
- ID: [Text Input]
- Doctor: [Text Input]
- Status: [Dropdown Menu, currently showing 'All']
- Exam Date:
 - Today [Dropdown Menu]
 - 03/15/2021 [Date Picker] -- 03/15/2021 [Date Picker]

Buttons: [Search] [Cancel]

Figure 4-13 Patient Record Search Screen

2. Tick and enter the search conditions.
3. Click **Search** and the search results are displayed on the **Patient List** screen.

■ **To set patient lists**

Perform the following steps.

1. Click  (**F10**) to enter the **Settings** menu.

The screenshot shows a settings interface with the following elements:

- List**
 - Gender
 - Applicant
 - Accession Number
 - Age
 - Endoscope
 - Exam Date
 - Endoscope SN
- Export Path**
 - U-disk/Export/Name/Exam No.
 - U-disk/Export/Name/Exam No./ID

Buttons: [Save] [Exit]

Figure 4-14 Patient List Settings Menu

2. Enter the patient list settings screen, tick the items to be displayed on the patient list and the patient list export path, and click **Save**.

■ To view patient records

Select a record on the **Patient List** screen, and then click **View (F2)** to enter the **Details** screen. The user can view the exam report of the patient and the images and videos saved during the exam on the **Details** screen.

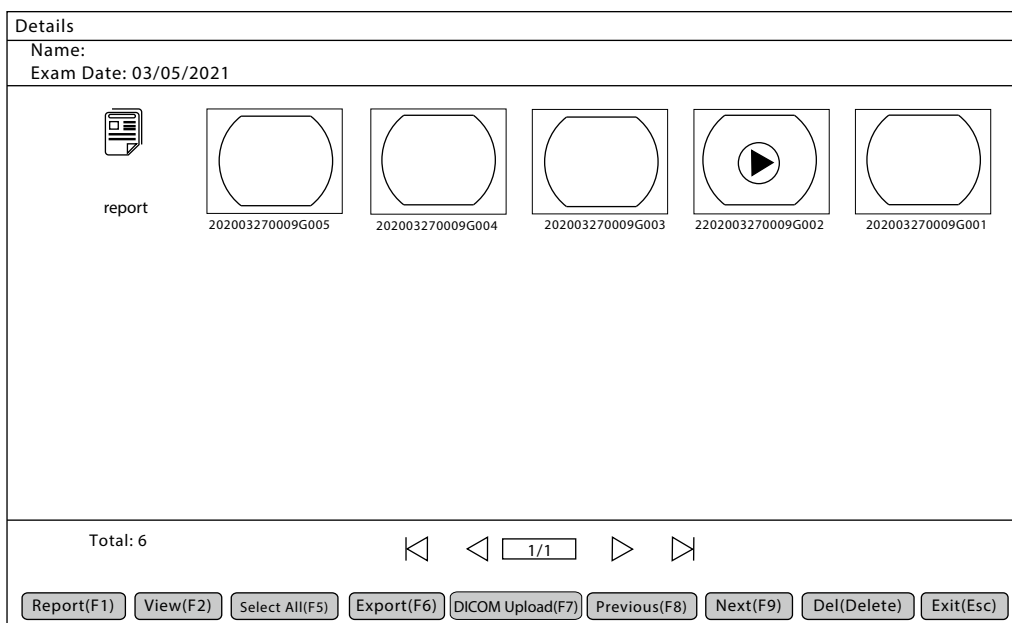

Figure 4-15 Details Screen

Report (F1)	Enter the Report Edit screen.
View (F2)	Enter the image editing screen, the video playing screen or the Report Edit screen.
Select All (F5)	Select all the thumbnails.
Export (F6)	Export the selected reports, images and videos.
DICOM Upload (F7)	Upload the selected report and images to the DICOM server.
Previous (F8)	View the previous patient record.
Next (F9)	View the next patient record.
Del (Delete)	Delete the selected report, images and videos.
Exit (Esc)	Return to the Patient List screen.

■ To cancel the exam

Perform the following steps.

1. Select a patient record being examined on the patient list screen.
2. Click **Cancel Exam (F3)** to enter the **Cancellation Reason** screen.
3. Select a cancellation reason, and click **OK** to cancel the exam.

■ To export patient records

Perform the following steps.

1. Open the protective cover  of the USB port on the front panel, and connect a USB drive to the device.
2. Enter the **Patient List** screen. Click **Export (F6)** to export the patient records.

- After the export is completed, press the  button on the front panel to stop data transmission, and remove the USB drive from the device.

■ To upload patient records to DICOM server

Perform the following steps to upload patient records to DICOM server.

- Select the desired patient records.
- Click **DICOM Upload (F7)** to upload the report to the DICOM server.

■ To delete patient records

Perform the following steps.

- Select the desired patient records on the **Patient List** screen.
- Click **Del (Delete)**, and click **OK** in the pop-up dialog to delete the selected record.

4.10 Editing and Printing Reports

Press the **F12** key on the keyboard, or click the  icon in the lower right corner of the main screen to enter the **Report Edit** screen, as shown in Figure 4-16.

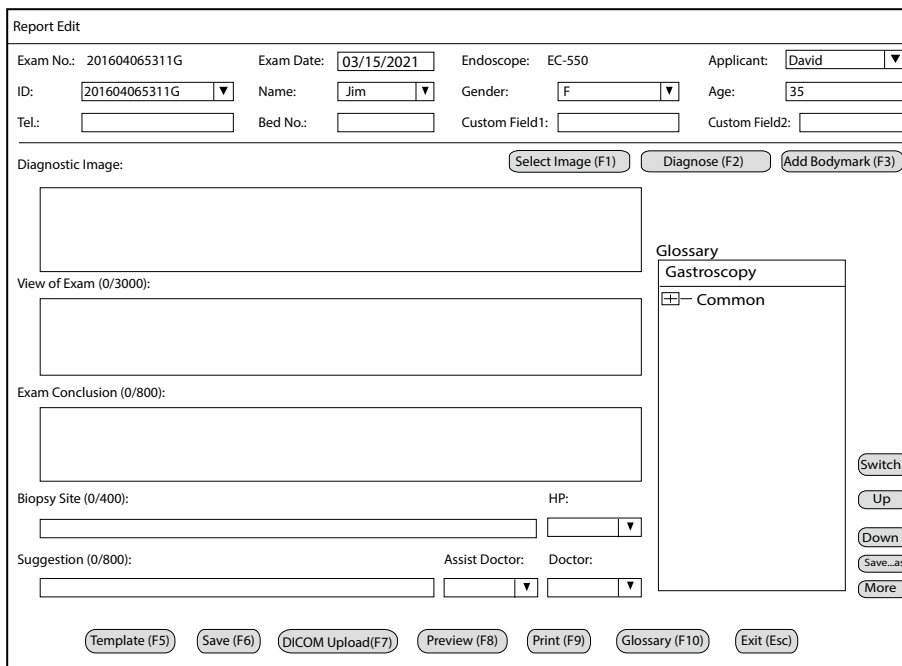

The screenshot shows the 'Report Edit' interface. At the top, there are fields for Exam No. (201604065311G), Exam Date (03/15/2021), Endoscope (EC-550), and Applicant (David). Below these are fields for ID (201604065311G), Name (Jim), Gender (F), and Age (35). There are also fields for Tel., Bed No., Custom Field1, and Custom Field2. A 'Diagnostic Image' section contains a large empty box and buttons for 'Select Image (F1)', 'Diagnose (F2)', and 'Add Bodymark (F3)'. The 'View of Exam (0/3000):' and 'Exam Conclusion (0/800):' sections also have large empty boxes. Below these are fields for 'Biopsy Site (0/400):' and 'HP:'. The 'Suggestion (0/800):' section has a large empty box and fields for 'Assist Doctor:' and 'Doctor:'. On the right side, there is a 'Glossary' panel with 'Gastroscopy' and 'Common' listed, and buttons for 'Switch', 'Up', 'Down', 'Save...as', and 'More'. At the bottom, there is a row of function buttons: 'Template (F5)', 'Save (F6)', 'DICOM Upload(F7)', 'Preview (F8)', 'Print (F9)', 'Glossary (F10)', and 'Exit (Esc)'.

Figure 4-16 Report Edit Screen

4.10.1 Annotating Images

Body marks and organ names can be added to distinguish the endoscopic images of different examined areas.

Perform the following steps.

- Click **Selected Image (F1)** to enter the **Report Edit** screen.
- Click twice the image that needed to be insert into the report and this image will be displayed in the image diagnosis area.
- Click **Add Bodymark (F3)** to add a body mark.

Figure 4-17 Adding Body Mark

- Add** Add an organ name or a lesion name.
- Delete** Delete an organ name or a lesion name.
- Previous page** Select the previous page.
- Next page** Select the next page.
- Clear** Clear the bodymark, organ name and the lesion name.

■ **To add a body mark**

Perform the following steps.

1. Select an image from the **Diagnostic Image** area on the **Report Edit** screen.
2. Select an arrow mark or the point mark.
3. Move the body mark to the desired position on the indicating diagram by using the trackball, and press the confirm key.

■ **To add an organ name or a lesion name**

Perform the following steps.

1. Select an image from the **Diagnostic Image** area on the **Report Edit** screen.
2. Select the organ name or lesion name on the report edit screen, or click the image twice to input the organ name or lesion name directly.
The organ name and lesion name are shown under the image.

■ **To delete notes**

Perform the following steps.

1. Select an image with an indicating diagram from the **Diagnostic Image** area on the **Report Edit** screen.
2. Click twice the organ name or lesion name to delete the notes, or click **Clear** to delete all notes.

4.10.2 Glossary

Perform the following steps.

1. Select items in the glossary and add the items and details into **Exam Conclusion** and **View of Exam** on the **Report Edit** screen.

2. Select a glossary and add the glossary and its description into the exam view box and exam conclusion box.

The following operations can also be performed in the report edit screen:

- Click **Glossary (F10)** to hide the glossary.
- Click **Switch** to switch the examination item.
- Click **UP/ Down** to get more items.
- Click **Save...as** to save the examination view and conclusion as the glossary.

3. Click **More** to get into glossary screen.

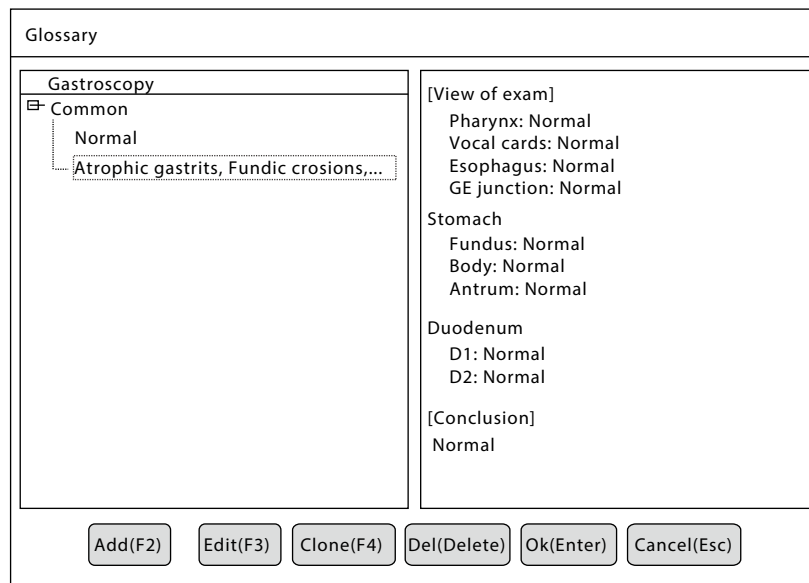

Figure 4-18 Glossary Menu

■ To add terms

Perform the following steps.

1. Click **Add (F2)** to display the term adding screen.

Glossary

* Group: ▼

* Title:

View of Exam:

Exam Conclusion:

(*) : Required Filed.

OK Cancel

Figure 4-19 Term Adding Screen

2. Enter information. Click **OK**.

■ **To edit terms**

Perform the following steps.

1. Select the desired term.
2. Click **Edit (F3)** to enter the term editing screen.
3. Enter information. Click **OK**.

■ **To copy terms**

Perform the following steps.

1. Select the desired term.
2. Click **Clone (F4)** to enter the term copying screen.
3. Enter information on the text boxes beside. Click **OK**.

On the **Glossary** menu, you can also perform the following operations.

- Click **Del (Delete)** to delete the selected term from the glossary.
- Click **OK (Enter)** to exit the **Glossary** menu and add the selected term to the corresponding text boxes on the **Report Edit** screen.
- Click **Cancel (Esc)** to return to the **Report Edit** screen.

4.10.3 Setting Report Template

On the **Report Edit** screen, click **Template (F5)** to enter the **Template** screen to set the report template.

Figure 4-20 Template Menu

Perform the following steps.

1. Select the desired report layout from the drop-down list beside **Template**. Click **Preview** to preview the report layout.
2. Select the desired items to be displayed on the report.
3. Click the corresponding dialog box for the desired operation:
 - Click **Default** to restore default report template settings.
 - Click **Save** to save the current report template settings.
 - Click **Exit** to exit the **Template** menu and return to the **Report Edit** screen.

4.10.4 Uploading Reports to DICOM sever

Click **DICOM Upload (F7)** to upload the report to the DICOM server.

4.10.5 Printing a Report

Perform the following steps.

1. Perform print settings. For details, refer to Section 5.3 Contextual Model Settings.
2. Enter the Report **Edit** screen.
 - Click **Preview (F8)** to preview the report. If necessary, you can adjust the report.
3. Click **Print (F9)** to print the report.

4.11 Powering Off the Device



Do not cut off the power supply before shut down its power supply. Otherwise the device may be damaged.

Perform the following steps.

1. When the main screen or login screen is displayed, press and hold the  button on the front panel of the device for 3 more seconds to power off the device. Then the power indicator is off.

2. Set the main power switch on the rear panel of device to the  position.
3. Power off all the peripherals (such as the monitor and light source) connected to the device as instructed in relevant user manuals.

This page is intentionally left blank.

5 Settings

System settings are used for setting the startup status of the device.

All the customized settings can be saved in the system and applied each time you perform an examination.

System settings include video parameter settings, general settings, contextual model settings and DICOM settings. You can press the **F1** key to enter the **System Settings** menu and make settings on the screen:

- Press the **F1/F2/F3/F4** key or click each tab page to enter the corresponding screen.
- Move the cursor to a setting item by using the trackball and select the setting item by pressing the confirm key on the keyboard.
- Select a setting from the drop-down list.
- Click **Save** to save the current settings.
- Click **Default** to restore default settings.
- Click **Exit** to exit and return to the main screen.

5.1 Video Parameter Settings

System Settings			
Video Parameters (F1)	General Settings (F2)	Contextual Mode (F3)	DICOM Setting (F4)
Primary Video		Save	
Output Type:	DVI + VGA	Image Format:	jpg
*Resolution:	Auto	Video Format:	mkv
Contour Shape:	Round	Video Segmentation:	Inf
Display Size:	Big	Quality:	High
Secondary Video		Information Storage: Settings	
*Video Standard:	PAL	Video Print	
Output Info:	Settings	<input checked="" type="checkbox"/> Save printed video	
Layout:	Style 1	Video Printer:	USB
	Example	Driver Type:	
Freeze		Select Reinstall	
Freeze Time:	Inf	Light Source Settings	
PBP:	Open	Light Source Model:	VLS-50T
PBP Position:	Left-down	Light Mode:	WL->SFI->VIST
PBP Size:	Big		
(* : The item takes effect after restart.)			
Default		Save	
Exit			

Figure 5-1 Video Parameters

Area	Item	Description
Primary video	Output	Set the output type of the primary video.
	*Resolution	Set the resolution of the primary video. <ul style="list-style-type: none"> If 1920×1080 is selected, the optimum resolution of the monitor connected to the device is 1920×1080. If 1920×1200 is selected, the optimum resolution of the monitor connected to the device is 1920×1200. If Auto is selected, the system adapts with an appropriate resolution automatically.
	Contour Shape	Set the contour shape.
	Display Size	Set the video area size of the main screen.
Secondary video	*Video Format	Set the video format of the secondary video.
	Output Info	Click Settings and tick the content you want to display in the secondary video or video printing.
	Layout	Set the layout of the secondary video. Click Example to view the image layout of the selected style.
Freeze	Freeze Time	Set the display time of a frozen endoscopic image on the screen. The unit is second. Inf indicates that the frozen image is displayed on the screen all the time.
	PBP	Open or close the PBP function. If open is selected, a small video window appears on the main screen after an image is frozen.
	PBP Position	Set the display position of the small video window on the main screen.
	PBP Size	Set the PBP size.
Save	Image Format	Set the default image storage format.
	Video Format	Set the default video storage format.
	Video Segment	When the storage mode is Local , the video can be segmented. <ul style="list-style-type: none"> If the setting is None, the video is not segmented. If the segment value is set, the video can be segmented according to the value.
	Quality	Set the quality of the recorded video.
	Information Storage	Click Settings to set the storage information necessary for saving the image.

Area	Item	Description
Video Printing	Printed video saving	Tick this option and the printed video image will be saved into the device synchronously and can be viewed, exported or updated on the Patient list screen.
	Video Printer	Select the video printer type. Select Close , and the video print function is closed.
	Drive Type	If USB is selected, a corresponding drive should be selected. Click Reinstall to reinstall the Drive Type .
Light Source Settings	Light Source Model	Display the connected light source model.
	Light Mode	Select the illumination modes of the connected light source.

5.2 General Settings

System Settings

Video Parameters (F1) | **General Settings (F2)** | Contextual Mode (F3) | DICOM Setting (F4)

Hospital Name:

Full-screen Display: Manufacturer Logo

Main screen content: Name Gender Age DoB
 Applicant ID Exam No.

Logo: (jpg/bmp/png)

Time Other

Format:
* Language:

Date:
Contact us

Time:
Facebook ID: sonoscape medical corp

Time Zone:

Time Server IP:

Startup time synchronization

Wechat Official Account Device Information

(* : The item takes effect after restart.)

Figure 5-2 General Settings

Area	Item	Function
-	Hospital Name	Set the hospital name.
-	Full-screen Display	Tick to display or hide the manufacture logo in the full-screen display
-	Main screen content	Select the main-screen contents.
-	Logo	Load the hospital logo to the report. Supported image formats are jpg, bmp and png.

Area	Item	Function
Time	Type	Set the system time format.
	Date	The default date is the current day.
	Time	The default time is the current time.
	Time Zone	Set the time zone.
	Time Server IP	Input the time server IP. Click Time Synchronization to synchronize the system time and the server time.
	Startup time synchronization	Tick this option and the system time and the server time will synchronized when powering on the device.
Other	Language	Set the system language.
	Wechat Official Account	Scan the Wechat official account of the manufacturer.
	Device information	Scan the QR to get more device information.

5.3 Contextual Model Settings

Figure 5-3 Contextual Model Tab

Area	Item	Function
Patient Info	Auto Match	If this item is selected, after a user inputs a patient name or ID on the main screen, Order screen, or Report Edit screen, the system will load patient information to the corresponding screen automatically. If this item is not selected, the system will not load patient information automatically.

Area	Item	Function
Report Print	Default Printer	Options: USB Printer and Network Printer
	Paper Size	Options: A4 (210mm*297mm) and Carta (216mm*279mm)
	Drive Type	Click Select to enter the Drive Type menu. Enter keywords in the text box to search the corresponding drive quickly, select the drive and click OK to confirm. NOTE: <i>If the corresponding drive cannot be found, click Help to conduct system inspection and proceed with the instructions.</i>
	Network Printer IP	If a network printer is set as default, set the correct printer drive. Click Search and select the IP address of an appropriate printer from the displayed network printer list and click OK to print.
Local	Local IP	Set the local IP address.
	Netmask	Set the netmask.
	Gateway	Set the gateway.
	MAC Address	System automatically generates the address.

5.4 DICOM Settings

■ Basic Settings

System Settings

Video Parameters (F1)	General Settings (F2)	Contextual Mode (F3)	DICOM Setting (F4)
-----------------------	-----------------------	----------------------	--------------------

Basic Settings

Basic Settings _____

Storage Setting

Station Name:

Storage Commitment

*Local AE Title:

Worklist

*Timeout(s):

MPPS

*Port:

(*: Required Filed.)

Figure 5-4 Basic Settings

Item	Description
Station Name	Input the name of the workstation.
*Local AE Title	Set the application entity (AE) title of the device.

Item	Description
*Timeout(s)	Set the time limit for network connection.
*Port	Enter the port number of the device.

■ **Storage Settings**

Figure 5-5 Storage Settings

Item	Description
Enable	Tick the option to enable the storage server feature.
Upload image once it is saved	Tick it to send the image to the DICOM server once it is saved in the device.
Upload PDF reports	Tick it to send the PDF report to the DICOM server.
*Server Name	Enter the name of the storage server.
*Server IP	Enter the IP address of the storage server.
*Port	Enter the port number of the storage server.
*AE Title	Enter the application entity (AE) title of the storage server.

Click **Echo** to verify the connection between the system and the DICOM storage server after you edit the local settings, the basic settings and the storage settings. A prompt of successful connection pops up if the connection is verified.

■ Storage Commitment

The screenshot shows the 'System Settings' dialog box with the 'DICOM Setting (F4)' tab selected. The 'Storage Commitment' section is active, showing a list of settings on the left and their corresponding input fields on the right. The 'Enable' checkbox is currently unchecked. The 'Echo' button is highlighted. At the bottom, there are 'Default', 'Save', and 'Exit' buttons. A note indicates that asterisks (*) denote required fields.

System Settings	Video Parameters (F1)	General Settings (F2)	Contextual Mode (F3)	DICOM Setting (F4)
Basic Settings				Echo
Storage Setting		<input type="checkbox"/> Enable		
Storage Commitment		*Server Name:	<input type="text"/>	
Worklist		*Server IP:	<input type="text" value="..."/>	
MPPS		*Port:	<input type="text"/>	
		*AE Title:	<input type="text"/>	
(* : Required Filed.)				
<input type="button" value="Default"/> <input type="button" value="Save"/> <input type="button" value="Exit"/>				

Figure 5-6 Storage Commitment Setting

Item	Description
Enable	Tick the option and enable the storage commitment server function.
*Sever name	Input the storage commitment server name.
*Server IP	Input the IP address of storage commitment server.
*Port	Enter the Port number of the storage commitment server.
*AE Title	Enter the AE title of the storage commitment server.

Click **Echo** to verify the connection between the system and the storage commitment after you edit the local settings, the basic settings and the storage commitment settings. A prompt of successful connection pops up if the connection is verified.

■ **Worklist Settings**

Figure 5-7 Worklist Settings

Item	Description
Enable	Tick the option to enable the worklist server feature.
*Server Name	Enter the name of the worklist server.
*Server IP	Enter the IP address of the worklist server.
*Port	Enter the port number of the worklist server.
*AE Title	Enter the application entity (AE) title of the worklist server.
*Maximum Results	Set the maximum number of work orders that can be downloaded to the device.
Requested Procedure Description	Select None , Custom Field1 or Custom Field2

Click **Echo** to verify the connection between the system and the worklist server after you edit the local settings, the basic settings and the worklist settings. A prompt of successful connection pops up if the connection is verified.

■ MPPS Settings

Figure 5-8 MPPS Settings

Item	Description
Enable	Tick the option to enable the MPPS server feature.
*Server Name	Enter the name of the MPPS server.
*Server IP	Enter the IP address of the MPPS server.
*Port	Enter the port number of the MPSS server.
*AE Title	Enter the application entity (AE) title of the MPPS server.

Click **Echo** to verify the connection between the system and the DICOM MPPS server after you edit the local settings, the basic settings and the MPPS settings. A prompt of successful connection pops up if the connection is verified.

This page is intentionally left blank.

6 DICOM

DICOM (Digital Imaging and Communications in Medicine) is a standard created by National Electrical Manufacturers Association (ACR-NEMA) to regulate the distribution and viewing of medical images such as endoscopic images and videos.

The device is configured with the DICOM module, and you can:

- Search the archived patient information on the DICOM server, and copy the patient information to the device.
- Send patient information and images stored on the device to the DICOM server.

DICOM service of the device consists of DICOM storage, DICOM worklist, MPPS, storage commitment and DICOM queue.

If you need DICOM 3.0 Compatibility Declaration, contact the manufacturer.

6.1 DICOM Connection

Perform the following steps.

1. Connect the device to the local network by using a network cable.
2. Edit the settings for the local network and the DICOM server. For details, refer to Section 5.3 Contextual Model Settings and Section 5.4 DICOM Settings.
3. If the verification is successful, you can use the DICOM service.

NOTE:

Ensure that the device is connected to the DICOM server before using the DICOM service. Otherwise, the service cannot be used.

6.2 DICOM Storage

DICOM storage is used to send patient data to the DICOM storage server for storage.

■ Storing Current Patient Data

Perform the following steps.

1. Press the **F2** key on the keyboard to display the **Mode Settings** menu, click the  icon, and set the function of the remote button 0/1/2/3 or the left/right pedal of the footswitch to **Fast Upload**.
2. Press the corresponding button or **Alt+U** on the keyboard to send the current patient data to the DICOM storage server.

■ Storing Patient Data

Perform the following steps.

1. Press **Alt+F3** on the keyboard to enter the **Patient List** screen.
2. Select the desired patient records.
3. Click **DICOM Upload (F7)** to send the patient data to the DICOM storage server.
 - To save the image only, select a patient record, and click **View** to enter the **Details** screen. Select the desired images, and click **DICOM Upload (F7)** to send the selected images to the DICOM storage server.

- To save a report only, select a patient record, and click **Report** to enter the **Report Edit** screen. After editing the report, click **Upload** to send the report to the DICOM storage server.

Check the status of items sent to the MPPS server by the following ways.

- Select the **F3** key > the **F7** key on the keyboard to enter the DICOM Queue screen.
- Select **Alt+F3** > the **F11** key on the keyboard to enter the DICOM Queue screen.

6.3 DICOM Worklist

The DICOM Worklist is used to search the archived patient information on the DICOM server, and copy the patient information to the device for examination.

Perform the following steps.

1. Press the **F3** key on the keyboard to enter the **Order List** screen.
1. Click the  icon (**F10**) to enter the **Settings** menu.
2. Tick the items and fill in the text boxes beside the ticked items on the **Worklist Query** area of the **Settings** menu. Click **Save**.
3. Click **Download** and Worklists matching the query conditions will be downloaded from the DICOM server and displayed on the **Order List** screen.
4. Select the desired patient record, and click **Exam (F1)** to start the exam.

6.4 MPPS

MPPS is used to send exam status information to the MPPS server, and thus the DICOM server can obtain the exam progress in time.

Enter the DICOM queue to view the send status of MPPS server by the following ways.

- Press the **F3** key > the **F7** key to enter the **DICOM Queue** screen.
- Press **Alt+F3** > the **F11** key to enter the **DICOM Queue** screen.

6.5 Storage Commitment

Storage commitment is used to confirm whether the images or structured reports are successfully stored into the DICOM storage server.

Enter the DICOM queue to view the send status of storage commitment by the following ways.

- Press the **F3** key > the **F7** key on the keyboard to enter the **DICOM Queue** screen.
- Press **Alt+F3** > the **F11** key on the keyboard to enter the **DICOM Queue** screen.

6.6 DICOM Queue

Enter the DICOM queue to view the send status of MPPS server by the following ways.

Press the **F3** key > the **F7** key on the keyboard to enter the **DICOM Queue** screen.

Press **Alt+F3** > the **F11** key on the keyboard to enter the **DICOM Queue** screen.

DICOM Queue

ID: Name: Type:

Date: -- Status:

	Type	ID	Name	Service	Send Date	File Name	Size	Status	Details
1									

Total: 1

Figure 6-1 DICOM Queue

Perform the following steps.

1. Search for the patient information.
Enter the search criteria, such as **ID**, **Name**, **Date**, **Type** and **Status**, and then click **Search** to search for the desired information.
2. Check the sending status.
You can check the sending status by viewing **Status** and **Details**.
3. Deal with the patient information.
 - If the patient information fails to be sent, select the patient information and click **Refresh** to refresh it. If the patient information still fails to be sent, click **Resend** to send the patient information again.
 - Select the desired patient information, and click **Delete** to delete the patient information.

This page is intentionally left blank.

7 Maintenance and Storage

To ensure the safety and functionality of the device, please maintain and store the device as described in this chapter.

During use, any serious incident that has occurred in relation to the device should be reported to the local distributor and the competent authority of the Member State.



- The device should be powered off and unplugged before cleaning. Otherwise, electric shock may occur or the device may be damaged.
- To ensure the device performance, maintain the device periodically (not more than a year), and ensure that the grounding of the device is correct and complies with the safety requirements.

7.1 Cleaning the Device

If the device is contaminated, you should perform the following cleaning procedures immediately after use. If cleaning is delayed, residual debris will be solidified, and it may be difficult to effectively clean the device. Clean the device periodically.



- The device should be completely dried after being wiped with the dampened cloth. Otherwise, electric shock may occur.
- Wear personnel protective barrier when cleaning the device. Otherwise, blood, mucous membrane and other potential source of infection adhered to the device may cause infection.



Do not wipe light guide/air pump connector, other ports of the device and AC power outlet. Otherwise, it may cause damage.

Perform the following steps to clean the surface and keyboard.

1. Power off the device.
2. Dampen the lint-free soft cloth with 75% ethyl alcohol.
3. Use the lint-free soft cloth to clean the surfaces of device, keyboard and endoscope cable. Take special care and avoid to contact the pins inside the connector of endoscope cable.
4. Use a cotton swab to remove solids from between keys.

7.2 Replacing the Fuse



- Disconnect power cable before replacing the fuse. Otherwise, electric leakage may occur.
- Please use the rated fuse. Otherwise, electric leakage may occur.

Perform the following steps.

1. Power off the device and disconnect power cable from power outlet.
2. Take out the fuse box on rear panel with a slotted screwdriver.

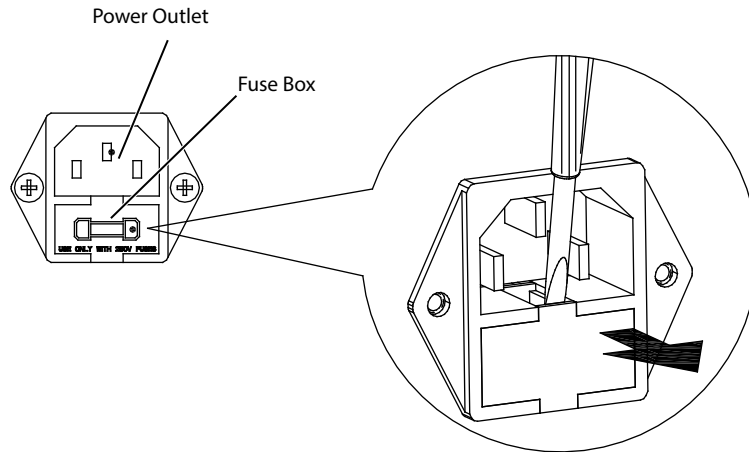

3. Replace the blown fuse.

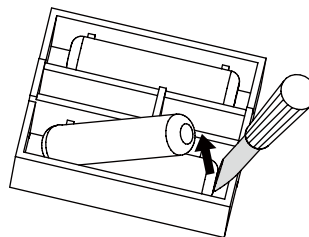

4. Push the fuse box back to the original place until it is in position.
5. Connect the power cable and turn on the main power switch of the device.
6. Press the power button and ensure that the power indicator turns on in blue. If the power indicator still cannot be turned on, please contact the local distributor of the manufacturer.

7.3 Storing the Device

Perform the following steps.

1. Power off the device and disconnect the power cable from the power outlet.
2. Disconnect all the peripherals from the device.
3. Place the device on a clean and level surface at room temperature.

NOTE:

- If the device is not used for a long time, you should power on the device to ensure that the device is functioning before performing an exam.
- To avoid malfunction, do not excessively bend, pull, twist or squeeze the power cable during storage.
- Store the device in the environment with sound ventilation and avoid sunlight.

7.4 Troubleshooting

In case of device problems, the device should be serviced by qualified technical personnel. If the problems still exist after servicing as described, stop using the device immediately and return it to the local distributor of the manufacturer for repair.

Descriptions	Inspection Items	Solutions
Power indicator does not turn on.	Power cable	Ensure that the power cable is connected firmly and the power voltage of outlet is appropriate.
	Fuse	Take off the fuse box and replace the fuse.

Descriptions	Inspection Items	Solutions
Power indicator turns on, but there is no image on the screen.	Connection between the device and endoscope	Ensure that the endoscope is connected to the device properly.
	Connection between the device and the monitor	Ensure that the monitor is connected to the device properly.
	Orientation of the distal end of the endoscope	Ensure that the distal end of the endoscope points at a bright area (such as fluorescent light) and normal image is displayed on the screen.
	Illumination	Power on the light source.
Image cannot be released after being frozen.	Relevant buttons on the endoscope	Check if the button set to freeze image on the endoscope can release image.
	The FREEZE key on the keyboard	Press the FREEZE key on the keyboard to check if it can release the image.
	Footswitch	Check if the pedal of the footswitch set to freeze the image can release image.
Image too bright or too dim.	Whether there are foreign objects on the lens of the endoscope	Refer to the relevant manual to remove the foreign objects.
	Illumination	Ensure that the light source is connected, powered on and can provide illumination.
	Light intensity	Adjust the light intensity to a suitable level.
	Brightness parameter value	Adjust the brightness parameters of the device and the monitor with appropriate values.

7.5 Device Disposal

The manufacture date of the device is on the label, and the expected service life of the device is five years with normal use. You should dispose of the device or its accessories in accordance with local laws or regulations. For detailed disposal information, consult the local distributor. The manufacturer is not responsible for any device content or accessories that have been discarded improperly.

7.6 Customer Service

Only the service personnel of or authorized by the manufacturer can service the device. Any feedback or inquiries concerning our product or services should be directed to the manufacturer.

Contact address: 2F, 12th Building, Shenzhen Software Park Phase II, Keji Middle 2nd Road, Nanshan District, Shenzhen, 518057, Guangdong, China

Tel: +86-755-26722890

E-mail: service@sonoscape.net

Appendix A Specifications

Item	Specification	
Type of protection against electric shock	Class I	
Degree of protection against electric shock	Type-BF applied part	
According to the degree of safety of application	Do not use the device with flammable anaesthetics (category AP) or flammable anaesthetics with oxidants (category APG).	
Work mode	Continuous	
White balance	Auto	
AGC (Automatic gain control)	On/Off	
Color tone adjustment	Red: -15 - +15, Blue: -15 - +15, chroma: -15 - +15	
Structure enhancement	<ul style="list-style-type: none"> ● Struct A: L1/L2/L3 The value range of each level is A0 - A15. ● Struct B: L1/L2/L3 The value range of each level is B0 - B15. 	
Edge enhancement	Level 1, 2 and 3. The value range of each level is 0 - 15.	
Color enhancement	Level 1, 2 and 3. The value range of each level is 0 - 15.	
Contrast	Low, medium and high	
Display area of CHb pseudo-color image	Small, medium and big	
Photometry	PEAK, AVE and Auto	
Zoom	Level 1, 2 and 3. The value range of each level is 1.0 - 4.0 (step 0.1).	
Image freeze/storage	Perform by endoscope buttons, keyboard or footswitch.	
Video resolution	≥ 960 × 720	
Rated voltage	100 - 240 V AC	
Supply frequency	50Hz/60Hz	
Input power	250VA	
Fuse	T3.15AH 250V	
Operation environment	Temperature	0 °C - 40 °C
	Relative humidity	30% - 80% (non-condensing)
	Atmospheric pressure	700 hPa - 1060 hPa

Item		Specification
Storage environment	Temperature	-5 °C - +40 °C
	Relative humidity	30% - 80% (non-condensing)
	Atmospheric pressure	700 hPa - 1060 hPa
Transportation environment	Temperature	-20 °C - +55 °C
	Relative humidity	20% - 90% (non-condensing)
	Atmospheric pressure	700 hPa - 1060 hPa
Running environment	Hardware environment	<ul style="list-style-type: none"> ● Hardware platform: X86 platform ● Operating system: Linux ● Development environment: Ubuntu ● Development tool: QT
	Software environment	<ul style="list-style-type: none"> ● Application software <ul style="list-style-type: none"> – HD550N, self-developed; – HD500Video, self-developed; – HD500Encoder, self-developed. ● System software <ul style="list-style-type: none"> Open source system, secondary developed by the manufacturer.
Security software		Firewall

Appendix B EMC Guidance and Manufacturer's Declaration



- The device is suitable for use in professional healthcare facility environment. Do not use it in domestic establishments and those directly connected to the public low voltage power supply network that supplies buildings used for domestic purposes.
- Do not use this device around strong electric field, electromagnetic field (e.g. MRI scan room) and mobile wireless communication devices. Using the device in an improper environment may cause malfunction or damage.
- Only the peripherals (such as endoscope, light source, etc.) provided or recommended by the manufacturer can be used. Using other devices may increase RF radiation and degrade the device performance of anti-electromagnetic interference.
- Use of this device adjacent to or stacked with other equipment should be avoided because it could result in improper operation. If such use is necessary, this device and the other equipment should be observed to verify that they are operating normally.
- Use of accessories and cables other than those specified or provided by the manufacturer of this device could result in increased electromagnetic emissions or decreased electromagnetic immunity of this device and result in improper operation.
- Portable RF communications equipment (including peripherals such as antenna cables and external antennas) should be used no closer than 30 cm (12 inches) to any part of the device, including cables specified by the manufacturer. Otherwise, degradation of the performance of this device could result.

B.1 Electromagnetic Emissions

Emissions Test	Compliance
Conducted and Radiated RF Emissions CISPR 11	Group 1 Class A
Harmonic Distortion IEC 61000-3-2	Not Applicable
Voltage Fluctuations and Flicker IEC 61000-3-3	Not Applicable

B.2 Electromagnetic Immunity

Immunity Test	Compliance Level
Electrostatic Discharge (ESD) IEC 61000-4-2	±8kV Contact, ±2kV, ±4kV, ±8kV, ±15kV Air
Radiated RF EM fields IEC 61000-4-3	3V/m
Electrical Fast Transient and bursts IEC 61000-4-4	±2kV for power supply lines, ±1kV for SIP/SOP ports

Immunity Test	Compliance Level
Surges IEC 61000-4-5	± 1 kV differential mode ± 2 kV common mode
Conducted Disturbances IEC 61000-4-6	3V 6V at ISM bands
Voltage dips and interruptions IEC 61000-4-11	0% U_T for 0.5 cycle at 0°, 45°, 90°, 135°, 180°, 225°, 270° and 315°
	0% U_T for 1 cycle Single phase: at 0°
	70% U_T for 25 cycle Single phase: at 0°
	0% U_T for 250 cycle
Power frequency Magnetic field IEC 61000-4-8	30A/m

This page is intentionally left blank.