

東星[®]

RM Series Rotary Gas Meter Manual

(Mechanical Type)



CONTENTS

I. Overview	2
II. Main features	2
III. Structure and working principle	3
IV. Technical performance indicator	5
V. Dimensions	5
VI. Installation	6
VII. Usage and precautions	9
VIII. Materials	11
IX. Packaging, transportation and storage	11

Safety measures:

1. If the downstream of the meter is the occasion where the gas consumption is temporarily interrupted, it's suggested to design the two-way metering or bypass piping, otherwise it is not recommended to use this product.
2. The meter coefficient has been set before leaving the factory, and the adjustment of the coefficient will affect the measurement of the meter. Users shall not make adjustments without authorization, otherwise they will bear corresponding legal responsibilities.
3. When the signal is required a remote transmission, an external power supply ($\leq 24\text{VDC}$) should be strictly followed the requirements of "Electrical Performance Instructions".
4. Strictly prohibited the opening in an explosive environment.
5. Replacement of components or structures will affect the explosion-proof performance.

1. Overview

RM series rotary gas meter adopts innovative technology and modular structure design concept to ensure the high reliability and high accuracy of the product, while reducing the user's purchase and maintenance cost. It has been widely used in the industrial and commercial trade measurement of urban gas.

2. Main features

1. The solid and durable design of the meter body structure, square impellers, supporting front plate, rotating main shaft and bearing has good mechanical rigidity;
2. The symmetrical impellers design of the typical square structure reduces the leakage of the instrument and expands the flow range;
3. The supporting bearing of the rotating main shaft of the meter is installed on the outside of the synchronization gear, which can realize online maintenance without removing the meter from the pipeline;
4. Adopt single-ended synchronous transmission, shorten the relative length of the meter body, save installation space, and make it easy for users to use and maintain;
5. The mechanical counter with an independent module structure has good versatility and interchangeability, reducing user parts inventory;
6. High-rigidity structure design and high-strength surface hardness treatment make the instrument's normal operating life up to 16 years;
7. Wide flow range, high measurement accuracy, low starting flow and small pressure loss.
8. The protection grade of the meter casing is IP66.

3. Structure and working principle

3.1 Structure

The meter is composed of two parts: impeller sensing part and display, as shown in Figure 1.

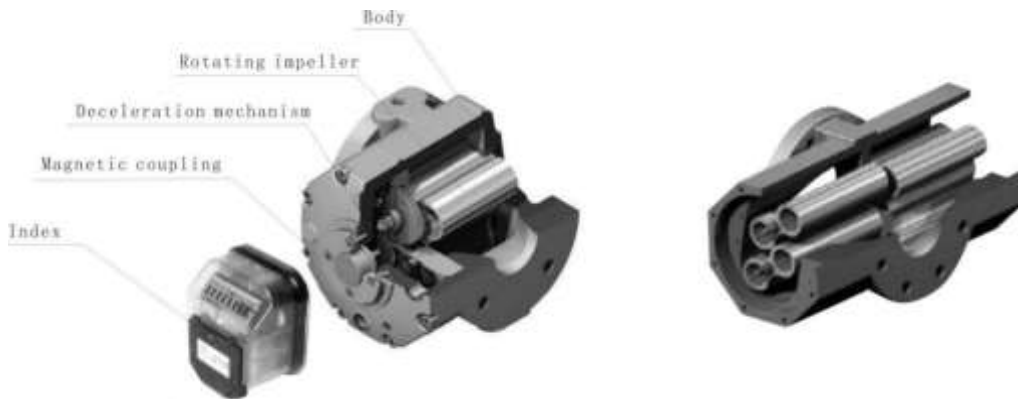

Figure 1

3.2 Working principle

Rotary gas meter is a kind of volumetric measuring instrument. When the gas passes through the meter (see Figure 2), the pressure difference generated between the inlet and the outlet acts on a pair of impellers connected with high-precision synchronous gears to drive the impellers to rotate. During this period, the enclosed space formed between the impellers and the inner wall of the housing and the gland is periodically inflated and exhausted. The speed of the impellers is proportional to the volume of gas passing through the meter. The rotation of the impellers is transmitted to the mechanical counter or output flow pulse signal through the magnetic coupler, so as to accumulate the volume flowing through the metering cavity to achieve the purpose of metering.

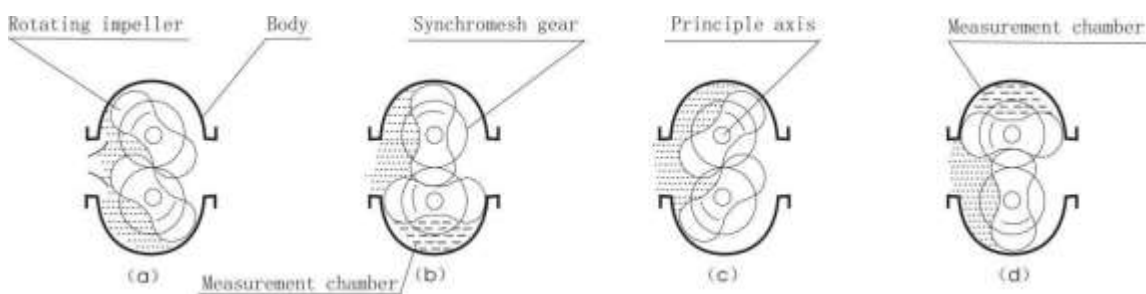

Figure 2 Structure schematic

3.3 Double impellers structure and characteristics

With the increase of gas pressure and flow, due to the action of the rotating impellers, the corresponding pulsating flow and airflow noise are generated inside the pipeline, which affects the metering accuracy and normal alternation of the meter, and affects the normal gas consumption of the gas equipment downstream of the meter.

RM series rotary gas meter adopts double impellers technology to divide the measuring room into two parts, which reduces the interference of pulsating flow and realizes accurate measurement of large flow (Figure3). It has the following advantages:

- Reduce the interference effect of pulsating flow, low airflow noise, high measurement accuracy and long service life;
- The typical shape of the impellers reduces pressure loss;
- The metering chamber is divided into two parts to increase the rigidity of the instrument housing and reduce the sensitivity of the meter to pipeline installation stress, excess flow, gas particles and pressure changes.
- Small structure, saving installation space, reducing overall operating costs and maintenance costs;
- Small size, light weight, easy to install and maintain.



Figure 3 Double impellers structure schematic

3.4 Display

Utilizing the rotation of the impellers, the magnetic coupler converts the working condition cumulative volume into a number of eight-digit . The circuit pulse generator is directly installed on the index, and the low-frequency pulse signal representing the flow can be used for volume correction or remote transmission reading.

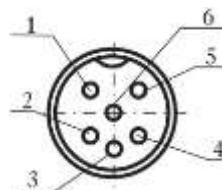

Pin Configuration / Connector

1 - 4 1 tr. = 1 imp.
 2 - 5 1 tr. = 1 imp.
 3 - 6 N.C. Reed Switch

Note:
 Only to be connected to an
 Intrinsic safe electrical circuit

Figure4 Mechanical index with LF output

4. Technical performance indicator

4.1 Implementation of standards and certification

This series of rotary gas meters comply with:

**EN 12480 European Union standards and
JIG 633-2005 "Volumetric Gas meter" verification procedures;**

Adopt:

**JB/T 7385-2015 "Rotary Gas Meters" industry standards and
Q/ZCY 20-2020 "RM Rotary Gas Meters" corporate standard;**

4.2 Accuracy level

Within the range, the accuracy level of the meter is divided into 1.0 or better.

1.0 class: $Q_t \sim Q_{max}$ is $\pm 1\%$, $Q_{min} \sim Q_t$ is $\pm 2\%$,
where $Q_t = 0.2Q_{max}$

4.3 Basic parameter excitation and technical guidance of the meter:

Type	G-Rating	Size (mm/inch)	Flow Range (m ³ /h)	Range-ability	Start Flow (m ³ /h)	Volume (dm ³)	RPM @Q _{min}	RPM @Q _{max}	Max. P. Loss (kPa)	Pulse Output m ³ /imp
RM-25	G10	25/1"	0.4~ 16	40:1	0.03	0.22			0.15	0.01
RM-40	G25	40/ 1 1/2"	0.5 ~ 40	80:1	0.06	0.26	31.56	1578.28	0.085	0.1
	G40		0.5 ~ 65	100:1	0.05	0.26	31.56	2525.25	0.145	0.1
RM-50	G16	50/2"	0.5 ~ 25	50: 1	0.05	0.692	12.06	603.17	0.04	0.1
	G25		0.5 ~ 40	65: 1	0.05	0.692	15.68	965.07	0.08	0.1
	G40		0.5 ~ 65	100:1	0.05	0.692	15.68	1568.24	0.10	0.1
	G65		0.5 ~ 100	160:1	0.05	0.692	15.68	2412.68	0.20	0.1
	G100		1.0 ~ 160	160:1	0.07	1.112	15.15	2424.57	0.22	1
RM-80	G100	80/3"	1.0 ~ 160	160:1	0.07	1.112	15.15	2424.57	0.22	1
	G160		1.6 ~ 250	160:1	0.10	2.31	11.54	1802.88	0.33	1
RM-100	G160	100/4"	1.6 ~ 250	160:1	0.10	2.98	8.96	1400.91	0.27	1
	G250		2.5 ~ 400	160:1	0.15	2.98	14.09	2241.46	0.39	1
	G400T		4.0 ~ 650	160:1	0.60	3.88	17.14	2785.98	1.00	1
RM-150	G400T	150/6"	4.0 ~ 650	160:1	0.65	3.88	17.14	2785.98	0.65	1
	G650T		6.5 ~ 1000	160:1	0.70	5.97	18.27	2811.15	0.75	1

5. Dimensions

5.1 The outline structure of the meter is shown in Figure 5,

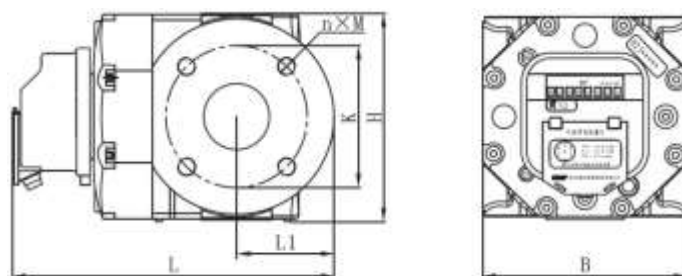

Figure5

Outline structure

5.2 the outline dimensions are shown in Table 2.

Table 2

Type	G-Rating	Size (mm)	n*M*L	K (mm)	B (mm)	L1 (mm)	H (mm)	L (mm)	Weight (kg)
RM-25	G10	25/1"	4×M12 ×40	85	171	70	141	248	5
RM-40	G25	40/1½"	4×M16 ×50	110	171	70	141	248	5
	G40		4×M16 ×50	110	171	70	141	248	5
RM-50	G16	50/2"	4×M16 ×50	125	171	85	180	275	10
	G25		4×M16 ×50	125	171	85	180	275	10
	G40		4×M16 ×50	125	171	85	180	275	10
	G65		4×M16 ×50	125	171	85	180	275	10
	G100		4×M16 ×50	125	171	103	185	325	13
RM-80	G100	80/3"	8×M16 ×50	160	171	103	185	325	13
	G160		8×M16 ×50	160	241	102	264	343	27
RM-100	G160	100/4"	8×M16 ×50	180	241	102	264	343	25
	G250		8×M16 ×50	180	241	131	264	388	30
	G400T		8×M16 ×50	180	241	245	264	550	45
RM-150	G400T	150/6"	8×M20 ×55	240	241	245	264	550	44
	G650T		8×M20 ×55	240	241	315	264	680	56

5.2 Plug dimensions are shown in Table3.

Table 3

	1½" inlet		2" inlet		3" inlet		4" inlet		6" inlet	
	ANSI	DIN	ANSI	DIN	ANSI	DIN	ANSI	DIN	ANSI	DIN
T	½UNC	M16	5/8UNC	M16	5/8UNC	M16	5/8UNC	M16	3/4UNC	M20
L	19	24	24	24	24	24	24	24	29	30

T= Thread diameter (mm)

L = Length of thread (mm)

6 Installation

Environmental conditions applicable to the Meter:

Mechanical class M1 &Electromagnetic class E1

Ambient temperature range from -25°C to +55°C Meter can be placed in the open air.Avoid direct sunlight on the meter.

- 1) Check the meter for damage due to transportation and handing.The rotors should rotate freely.
- 2) Check the flow direction,as indicated on the type plate.In case the flow direction is incorrect,the meter has to be replaced by one with correct flow direction. For Pr and T positions see figure 5 and 6.
- 3) The installation must be free of dirt,welding beads and pipe scale.The piping on the inlet side of the meter must be clean.It is recommended to install a 100 micron filter upstream of the meter.For new installations it is recommended to install a wire mesh screen (250 micron) for first weeks of operation.
- 4) The meter must be installed free of piping strain.
- 5) Level the meter to within 5mm/m side-to-side and front-to back

- 6) The maximum torque on the flange bolts is:
 - 1/2"UNC→55Nm;
 - M16(5/8"UNC)→130Nm;
 - M20(3/4"UNC)→180Nm;
 - Fasten the bolts crosswise.
- 7) The index can be rotated for about 350 degrees.To change from horizontal to vertical rotate the index 270 degree clock wise.
- 8) The meter is shipped without oil in the reservoir.Fill the meter at the front side to the indicated level with the oil supplied (see fig. 5 and 6). For a correct reading of the oil level it will take a few minutes for stabilizing.
- 9) Pressurize the meter with care to avoid overloading.The pressure change should never exceed 350mbar/sec.
- 10) Connect the electrical pulses accordance with the connection diagrams fig.4.
The connector is in conformance with IP67 as long as the companion plug or the protection cap is connected.
- 11) An indication of the meter condition can be obtained by analyzing the pressure drop over the meter (Pm- vs. P-point).It is recommended that the pressure drop over the new meter is measured.This value can be compared to future measurement.

PRECAUTIONS:

- * Never use the meter as a distance piece during welding.
- * The meter must be out of service and depressurized before fill or adding oil.
- * Before removing the meter the oil should be drained.
- * The meter should be transported and stored with the rotor axis in a horizontal position.
- * Use only devices with electrical characteristics as recommended (connection diagram fig.4)
- * The maximum torque on the p-pm connection is: 30Nm
- * To tighten the coupling.Use 2 wrenches to avoid of the P-Pm connection thread in the body.

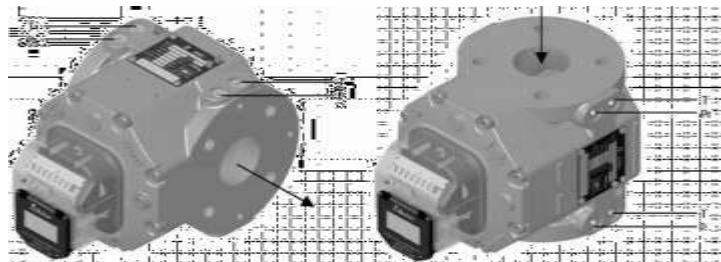

Figure 5 Flange to Flange: 171mm

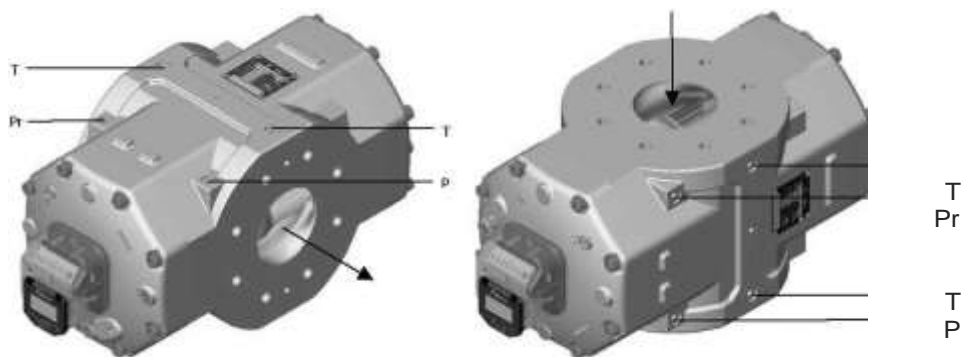

Figure 6 Flange to Flange: 241 mm

6.1 Installation method

6.1.1 Vertical installation (see Figure 7): When installed vertically, the gas inlet must be at the top, and the airflow flows from top to bottom, that is, top in and bottom out. The company recommends that users use vertical installation as much as possible. Vertical installation is helpful to the impeller's self-cleaning ability against debris.

6.1.2 Horizontal installation (see Figure 8): When installed horizontally, the axis of the inlet and outlet of the meter should not be lower than the axis of the pipeline to prevent impurities in the gas from staying in the meter and affecting normal operation. At the same time, the meter flange should be directly connected to the filter flange.

6.1.3 Regardless of vertical or horizontal installation, the impeller shaft in the meter must be in a horizontal position.

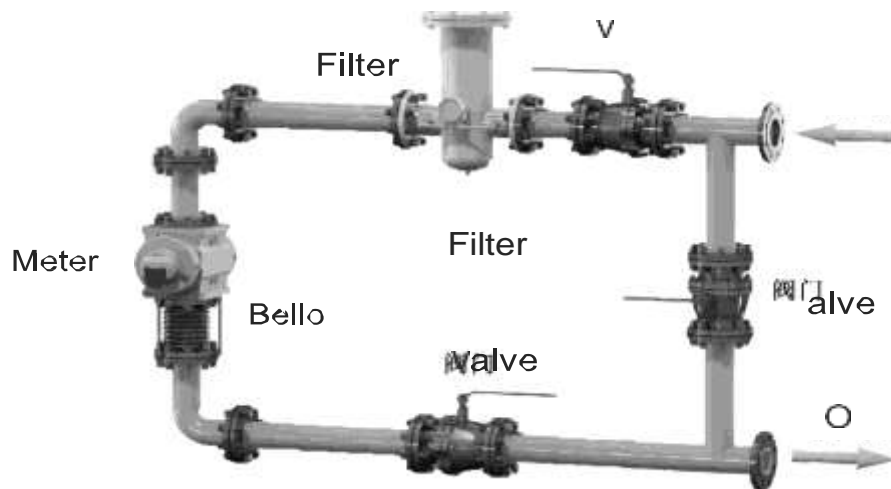

Figure 7 Vertical installation

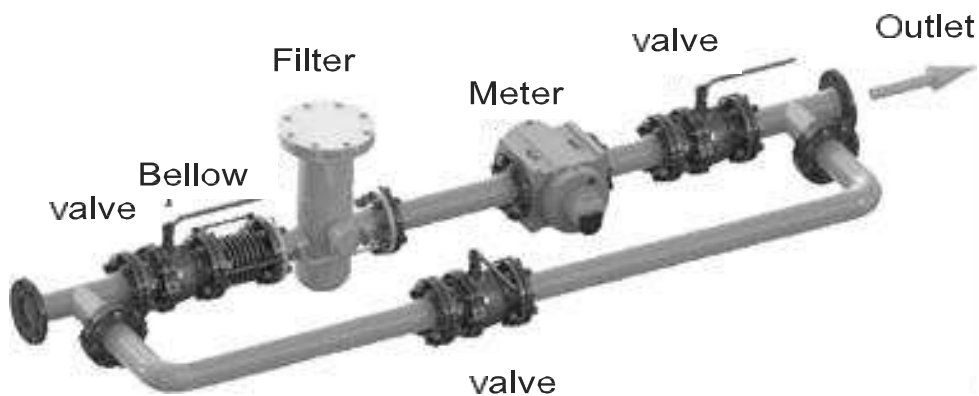

Figure 8 Horizontal installation

6.2 Installation considerations

- 6.2.1 It is not allowed to appear the installation stress on the meter, so as not to damage the meter or affect its performance.
- 6.2.2 The connection between and the inlet and outlet of the pipeline should be installed coaxially.
- 6.2.3 If there may be liquid in the measured medium, the meter should be installed vertically so that the liquid can be continuously discharged from the meter.
- 6.2.4 While the outdoors installing, the upper part should be covered to prevent rain and sun exposure.
- 6.2.5 There should be no strong magnetic field interference and strong mechanical vibration around the meter.
- 6.2.6 The meter is an explosion-proof product, so installation and maintenance should be performed in accordance with relevant explosion-proof requirements.
- 6.2.7 According to the installation position of the meter, in order to facilitate reading, the meter display should be turned to a proper position.
- 6.2.8 Oil lubricating must be taking before operation after installation .

7. Usage and Precautions

- 7.1 The rotary gas meter should be used under the specified flow range and working conditions to obtain the desired accuracy and normal service life. The over-speed rotation of the internal impeller and solid debris will cause premature wear and damage of the meter. The key to successful operation is to select the appropriate meter specification, correct installation, and proper operation and maintenance according to the flow range used.
- 7.2 When carrying out pipeline system inspection, testing and pipe cleaning operations, the meter should be removed to avoid serious damage to the measuring components.
- 7.3 Conditions of usage
 - Ring filling temperature: -30°C - $+60^{\circ}\text{C}$;
 - Relative humidity: 5%-95%;
 - Atmospheric pressure: 70kPa - 106kPa
 - Mechanical environment class: M1
 - Electron magnetic environment class: E1
 - (1) The flow rate, pressure and temperature range of the fluid to be tested should meet the requirements of this manual.
 - (2) The measured gas should be single-phase gas (including air), such as natural gas, industrial inert gas and other non-corrosive gases.
- 7.4 Lubrication

Each meter is equipped with a corresponding amount of special lubricating oil.

7.4.1 Refueling

- (1) Oil should be added before the meter's running.
- (2) The meter has two oil chambers (see Figure 9), which should be refueled separately.
- (3) The oil injection hole is located directly above the meter, and the oil drain hole is located below the meter, as shown in Figure 7 (both vertical and horizontal installations are the same).
- (4) Loosen the well and remove the oil filling screw at the top, being careful not to lose the "O" ring
- (5) Use a sharp-necked bottle filled with lubricating oil to fill the oil injection hole so that the oil level reaches the center of the oil standard sight glass. Refer to Table 4.

Note: The amount of oil should be appropriate. If too much oil is added, the lubricating oil will escape into the measuring chamber through the oil gap and affect the normal operation of the impeller.

- (6) Install and tighten the oil filling screw, and perform leak detection under operating pressure.

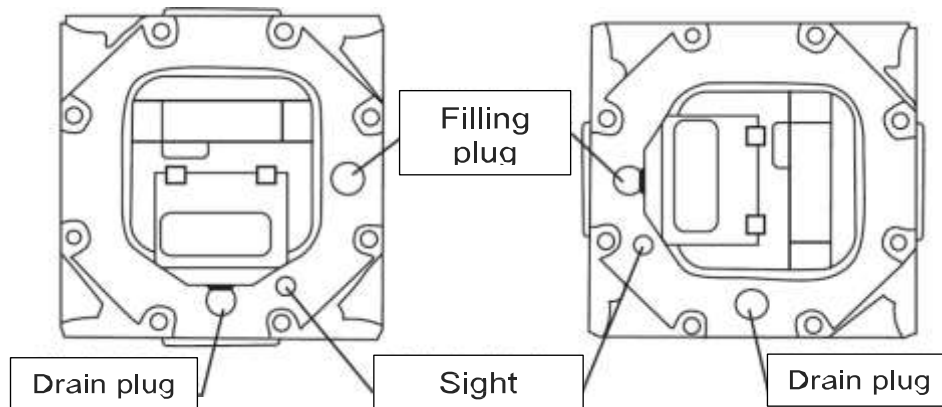

Figure 9 Oil filling and drain plug

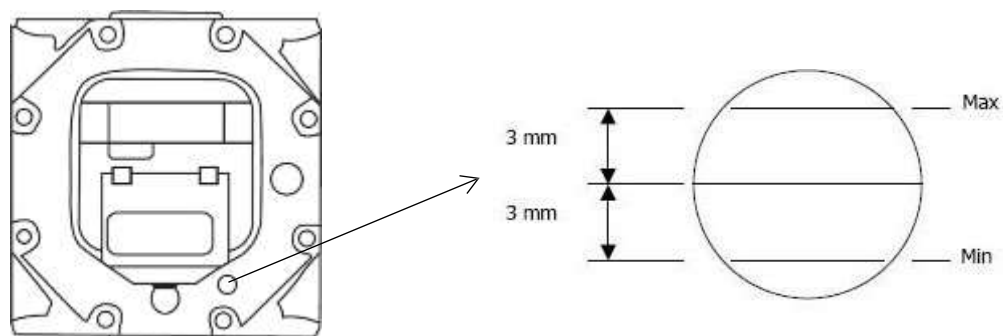

Figure 10 Oil filling line on sight glass

7.4.2 Oil change: If you find that the lubricating oil is black during using, it means that the oil has deteriorated or contains impurities. At this time, you should replace the new lubricating oil. If the oil level is 2mm below the center of the sight glass, that means the oil has been consumed. Please add to the center of the sight glass.

7.4.3 When the elbow of the meter is removed from the pipeline due to maintenance or calibration, the lubricating oil in the end cover must be drained.

Note: When replacing the lubricating oil, you must close the front valves and release the gas pressure in the meter.

Table 4

Lubricating oil filling amount (ml)			
Type		Horizontal installation	Vertical installation
RM-25	G10	12	12
RM-40	G25	15	40
	G40	15	40
RM-50	G16	25	120
	G25	25	120
	G40	25	120
	G65	25	120
	G100	25	120
RM-80	G100	25	120
	G160	70	310
RM-100	G160	70	310
	G 250	70	310
	G400T	70/each front and back	310/each front and back
RM-150	G400T		
	G650T		

7.5 Operation and precautions

7.5.1 Starting

In order to prevent the pressure shock from damaging the meter, it is necessary to achieve "pressure start", the operation method is as follows:

- (1) Close the valve behind the meter, slowly open the valve in front of the meter, so that the gas can fill the meter;
- (2) If there is a bypass pipeline, open the bypass valve first;
- (3) Slowly open the valve behind the meter, make it run at a small flow rate, and observe whether the operation is normal;

- (4) After the meter is operating normally, close the bypass valve and use the valve behind the meter to adjust the flow to the required value.

7.5. 2 Over-range protection

The rotary gas meter can withstand a gradual increase in the over range. At this time, it will not cause internal damage except for accelerated wear. However, the limiting gas flow rate that occurs when the pipeline is pressurized, exhausted or cleaned will suddenly accelerate the internal impeller of the meter, thereby Cause serious damage to the meter. Therefore, it must be slowly pressurized and started.

8. Materials

Part	Material
Meter body and covers	Aluminium hard anodized
Impellers	Aluminium hard anodized
Synchro plate	Aluminium hard anodized
Synchro gears	Stainless Steel
Main shafts	Stainless Steel
Timing Gears	Stainless Steel
Gears	Delrin
Bearings front / rear	Steel / Stainless Steel
Index	Poly Carbonate

9. Packaging, transportation and storage

- 9.1 The meter should be packed in a firm packaging box to prevent free movement in the box. It should be handled with care when handling, and rough handling is not allowed.
- 9.2 The transportation of the meter is carried out in accordance with the requirements of JB/T 9329-1999 "Basic environmental conditions and experimental methods for transportation, transportation and storage of instruments and meters".
- 9.3 The storage of the rotary meter should meet the following conditions:
- 1) Rain and moisture
 - 2) Relative humidity: not more than 75%
 - 3) Not subject to mechanical vibration or shock
 - 4) The surrounding environment does not contain corrosive gas
 - 5) Ambient temperature: -25°C---+55°C

ZHEJING CANGNAN INSTRUMENT GROUP CO., LTD.



Address: Lingxi Industry Demonstration Area, Cangnan County,
Zhejiang Province, P.R.China325800

Sales TEL:+86 400-111-8885 +86 (0)577 6483 9379

Service TEL:+86 400-111-8882

FAX: +86 (0)577 6483 9982 E-mail: cnybc@zjcnyb.com

