

## HAV IgM Rapid Test Cassette (Serum/Plasma) Package Insert

A rapid test for the qualitative detection of Hepatitis A virus in serum or plasma.  
For professional in vitro diagnostic use only.

### 【INTENDED USE】

The HAV IgM Rapid Test Cassette is a rapid chromatographic immunoassay for the qualitative detection of IgM antibody to Hepatitis A Virus (HAV) in serum or plasma.

### 【SUMMARY】

HAV is a positive RNA virus, a unique member of picornaviridae. Its transmission depends primarily on serial transmission from person to person by the fecal-oral route. Although hepatitis A is not ordinarily a sexually transmitted disease, the infection rate is high among male homosexuals, as result of oral-anal contact<sup>2,3</sup>. The presence of specific anti-HAV IgM in blood samples suggests acute or recent HAV infection<sup>4,6</sup>. The IgM antibody rapidly increases in titer over a period of 4-6 weeks post infection, and then declines to non-detectable levels within 3 to 6 months in most patients<sup>7</sup>.

The HAV IgM Rapid Test Cassette is to be used to detect anti-HAV IgM in less than 20 minutes by untrained or minimally skilled personnel, without cumbersome laboratory equipment.

### 【PRINCIPLE】

The test is based on a proprietary technology that combines the principles of immune-chromatography and fluid dynamics. The test has the recombinant mouse anti-human IgM immobilized on the membrane within the test zone. During the test the serum or plasma added on the sample port(S) reacts with mouse anti-human IgM on the membrane first. The buffer runs upward from buffer well (B), HAV antigen reacts to particle coated with mouse anti-HAV migrates through the test zone, the HAV antigens are captured by the HAV antibody in the first step. It indicates positive result when the test zone forms a colored line, no colored line in the test zone indicates a negative result. To serve as a procedural control, a colored line will always appear in the control line region indicating that proper volume of specimen has been added and membrane wicking has occurred.

### 【REAGENTS】

The test cassette contains anti-HAV antibody particles, HAV nature antigen on the antigen pad and mouse anti-human IgM on the membrane.

### 【PRECAUTIONS】

- For professional in vitro diagnostic use only. Do not use after the expiration date.
- The test should remain in the sealed pouch until ready to use.
- All specimens should be considered potentially hazardous and handled in the same manner as an infectious agent.
- The used test should be discarded according to local regulations.

### 【STORAGE AND STABILITY】

Store as packaged at room temperature or refrigerated (2-30°C). The test is stable through the expiration date printed on the sealed pouch. The test must remain in the sealed pouch until use. **DO NOT FREEZE**. Do not use beyond the expiration date.

### 【SPECIMEN COLLECTION AND PREPARATION】

- The HAV IgM Rapid Test Cassette can be performed using serum or plasma.
- Separate serum or plasma from blood as soon as possible to avoid hemolysis. Use only clear, non-hemolyzed specimens.
- Testing should be performed immediately after specimen collection. Do not leave the specimens at room temperature for prolonged periods. Serum and plasma specimens may be stored at 2-8°C for up to 3 days. For long term storage, specimens should be kept below -20°C.
- Bring specimens to room temperature prior to testing. Frozen specimens must be completely thawed and mixed well prior to testing. Specimens should not be frozen and thawed repeatedly.
- If specimens are to be shipped, they should be packed in compliance with federal regulations covering the transportation of etiologic agents.

### 【MATERIALS】

#### Materials Provided

- Test Cassettes
- Sample Droppers
- Package Insert
- Buffer
- Sample Dilution Tubes

#### Materials Required But Not Provided

- Micropipette
- Centrifuge
- Timer
- Specimen Collection Containers

### 【DIRECTIONS FOR USE】

Allow the test cassette, specimen, buffer and/or controls to reach room temperature (15-30°C) prior to testing.

#### 1. Sample Dilution

Use micropipette to add 50µL specimen into the sample dilution tube. Screw the lid tightly and shake it for 10 seconds to ensure the solution could be well mixed. Use the diluted sample as specimen for testing. See instruction below.

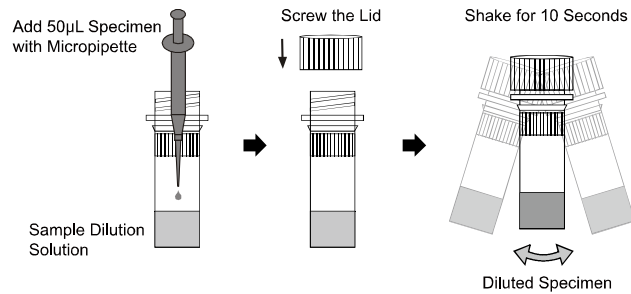

### 2. Testing Procedures

- Remove the test cassette from sealed pouch and use it within one hour. Best results will be obtained if the assay is performed immediately after opening foil pouch.
- Hold the dropper vertically, draw the diluted specimen from sample dilution bottle up to the fill line marked on the dropper as shown in illustration below (approx. 5µL), transfer the diluted specimen to the **sample area (S)** which has been marked on the test cassette. Or use micropipette to add 5µL diluted specimen into the **sample area (S)** which has been marked.
- Add 2 drops of buffer (approx. 80µL) into the **buffer well (B)** marked on the test cassette, start the timer. See illustration below.
- Wait for the colored line(s) to appear. Read the result at 20 minutes, do not interpret the result after 30 minutes.

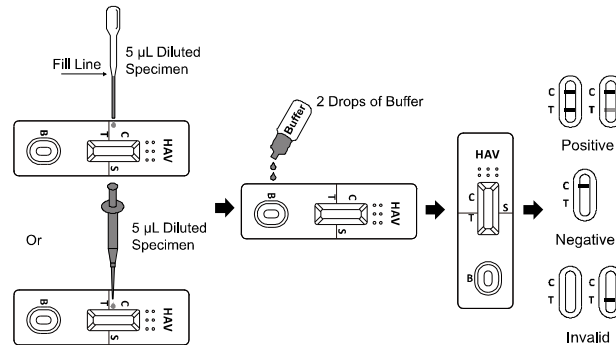

### 【INTERPRETATION OF RESULTS】

(Please refer to the illustration above)

**POSITIVE:** Two distinct colored lines appear. One colored line should be in the control region (C) and another colored line should be in the test region (T).

**\*NOTE:** The intensity of the color in the test region (T) will vary depending on the concentration of HAV IgM present in the specimen. Therefore, any shade of color in the test region (T) should be considered positive.

**NEGATIVE:** One colored line appears in the control region (C). No apparent colored line appears in the test region (T).

**INVALID:** Control line fails to appear. Insufficient specimen volume or incorrect procedural techniques are the most likely reasons for control line failure. Review the procedure and repeat the test with a new test cassette. If the problem persists, discontinue using the test kit immediately and contact your local distributor.

### 【QUALITY CONTROL】

An internal procedural control is included in the test. A colored line appearing in the control region (C) is an internal valid procedural control. It confirms sufficient specimen volume and correct procedural technique.

Control standards are not supplied with this kit; however, it is recommended that positive and negative controls be tested as a good laboratory practice to confirm the test procedure and to verify proper test performance.

### 【LIMITATIONS】

- The Assay Procedure and the Assay Result Interpretation must be followed closely when testing the presence of anti-HAV IgM in serum or plasma from individual subjects. Failure to follow the procedures may give inaccurate results.
- The HAV IgM Rapid Test Cassette is limited to the qualitative detection of anti-HAV IgM in human serum or plasma. The intensity of the test band does not have linear correlation with the antibody titer in the specimen.
- A negative result for an individual subject indicates absence of detectable anti-HAV IgM. However, a negative test result does not preclude the possibility of exposure to or infection with HAV.
- A negative result can occur if the quantity of the anti-HAV IgM present in the specimen is below the detection limits of the assay, or the antibodies that are detected are not present during the stage of disease in which a sample is collected.
- Some specimens containing unusually high titer of heterophile antibodies or rheumatoid factor may affect expected results.
- The results obtained with this test should only be interpreted in conjunction with other diagnostic procedures and clinical findings.

### 【EXPECTED VALUES】

The HAV IgM Rapid Test Cassette (Serum/Plasma) has been compared with a leading commercial HAV EIA test. The correlation between these two systems is 98.3%.

### 【PERFORMANCE CHARACTERISTICS】

#### Sensitivity and Specificity

The HAV IgM Rapid Test Cassette (Serum/Plasma) was compared with a leading commercial ELISA HAV IgM test; the results show that The HAV IgM Rapid Test Cassette (Serum/Plasma) has a high sensitivity and specificity.

Method	EIA			Total Results
	Results	Positive	Negative	
	HAV Rapid Test Cassette(Serum/Plasma)	Positive	118	
	Negative	6	466	472
Total Results		124	470	594

Relative Sensitivity: 95.2% (95%CI\*: 89.8%-98.2%)

\*Confidence Intervals

Relative Specificity: 99.1% (95%CI\*: 97.8%-99.8%)

Overall Accuracy: 98.3% (95%CI\*: 96.9%-99.2%)

### 【BIBLIOGRAPHY】

- Minor P. Picornaviridae. In: Francki RIB, Fauquet CM, Knudson DL, et al., eds. Classification and nomenclature of viruses (Arch Virol Supp 2). Wien: Springer-Verlag, 1991: 320-326.
- Keeffe EB. Clinical approach to viral hepatitis in homosexual men. Med Clin North Am. 1986;70(3):567-86.
- Ballesteros J, Dal-Re R, Gonzalez A, del Romero J. Are homosexual males a risk group for hepatitis A infection in intermediate endemicity areas? Epidemiol Infect. 1996; 117(1):145-8.
- Bradley DW, Maynard JE, Hindman SH, et al: Serodiagnosis of viral hepatitis A: Detection of acute-phase immunoglobulin M anti-hepatitis A virus by radioimmunoassay. J Clin Microbiol 1977; 5: 521-530.
- Decker RH, Kosakowski SM, Vanderbilt AS, et al: Diagnosis of acute hepatitis A by HAVAB-M : A direct radioimmunoassay for IgM anti-HAV. Am J Clin Pathol 1981;76:140- 147.
- Locarnini SA, Ferris AA, Lehman NI, et al: The antibody response following hepatitis A infection. Intervirology 1974; 4:110-118.
- Skinhoj P, Mikkelsen F, Hollinger FB. Hepatitis A in Greenland: Importance of specific antibody testing in epidemiologic surveillance. Am J. Epidemiol 1977; 105: 104-147

Number: 145004805  
Effective date: 2016-11-30