

Flow Sensor SpiroQuant A+

Use the advantages:

- Proven - constant temperature hot-wire anemometry
- Fast response time
- High product quality
- RoHS conform
- Biocompatible components
- Short delivery times
- Technical support
- Made in Germany
- Certified quality management system according EN ISO 13485

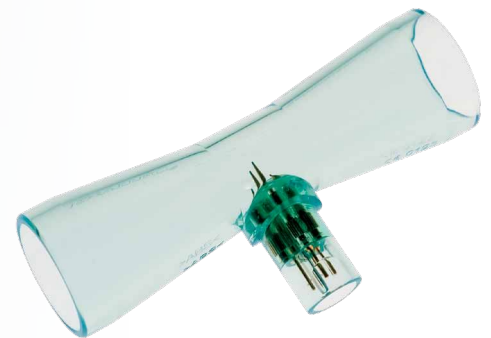

„We keep your devices operating at their best.“

EnviteC has been developing and manufacturing highly specialized products for medical applications. EnviteC's research and development activities are consistently aligned to customer and market needs – identification and optimization of sustainable product solutions are the main concerns of the company.

The company trusts in the quality of advanced production methods and processes. The result are flow measurement solutions for medical applications, which share the same extraordinary quality, excellent signal stability and reliable response for accurate readings. The flow sensor SpiroQuant A+ is a hot-wire sensor for measuring volume gas flow in anesthesia machines and ventilators. The flow sensor is not suitable for sterilization. For operation please refer to the instructions for use of the basic device to which this sensor is connected.

From standard sensors to customized sensors

Experienced EnviteC engineers analyze customer requirements. This input is used for different standard and OEM applications, and ongoing support is provided right up to the final integration in the solution. EnviteC designs customized sensors characterized by a maximum possible degree of precision.

Mechanical drawing (All dimension in mm)

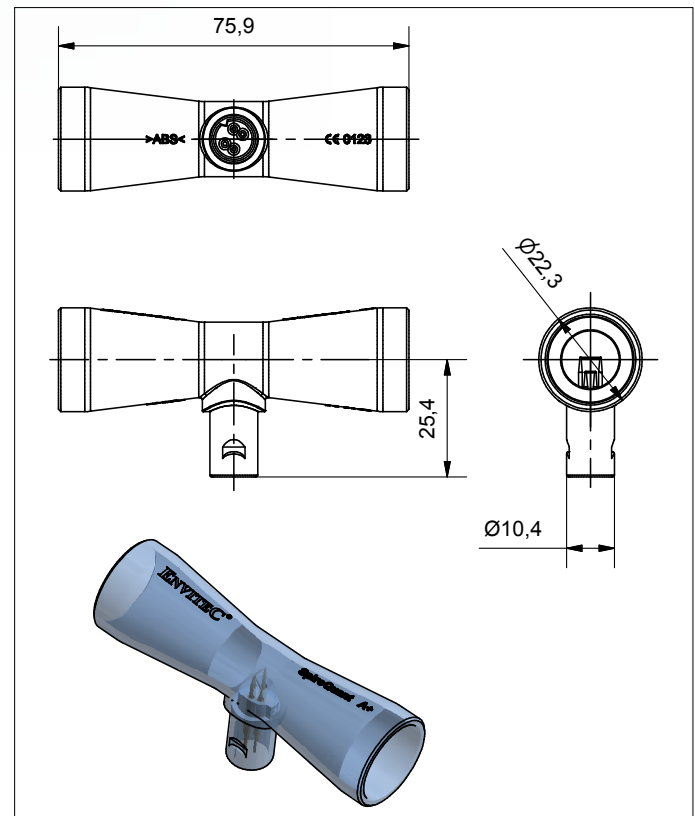

General tolerances ISO 2768-c

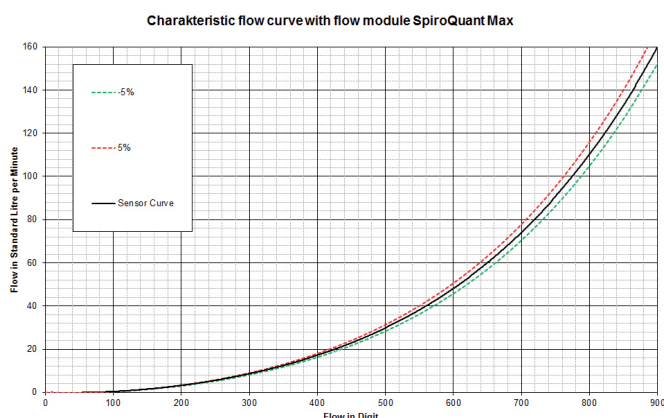

Additional information

If the sensor is intended to replace the original flow-sensing component in anesthesia machines or ventilators, consult the EnviteC XRL Cross Reference List under [www. EnviteC.com](http://www.EnviteC.com) for selecting the appropriate sensor.

For more information please contact us!

We look forward to assisting you either on the phone or in a personal talk.

Technical Specifications SpiroQuant A+

Measuring principle	Constant temperature hot-wire anemometry
Cross reference	Designed for EnviteC SpiroQuant MAX module; compatible with Dräger Spirolog® flow sensor
Sensor type	Disposable sensor for single patient use
Flow range	0 ... 160 slpm (standard liters per minute)
Accuracy	± 7% from measured value between 0 ... 10 l/min with flow module SpiroQuant MAX; ± 5% from measured value between 10 ... 160 l/min with flow module SpiroQuant MAX; (± 8 % reading used in Dräger ventilators)
Flow resistance	< 2.5 mbar (added resistance)
Operating temperature	+15 °C ... +40 °C
Operating time	Single patient use, applicable as long as a sensor calibration is successful
Storage temperature	-20 °C ... +70 °C
Storage ambient pressure	570 ... 1200 hPa
Storage humidity	5 % ... 95 % RH in original packaging
Storage time	Max. 5 years in original packaging
Cleaning / disinfection	Single patient use
Weight	Approx. 10 g
Electrical connection	Gold plated 4 pin (compatible with Dräger Spirolog® sensor)
Material	Housing parts: MABS; Contact pins: gold-plated; Hot-wires: platin
Part number	1000470: Flow sensor SpiroQuant A+ (Box with 5 pieces); 1001487: Flow module SpiroQuant MAX

All specifications are applicable at standard conditions:
1013 hPa, 25 °C dry ambient air



Certified Quality Management

EnviteC is maintaining a quality management system, which meets the requirements of EN ISO 13485 for medical devices.

EnviteC-Wismar GmbH a Honeywell Company

Alter Holzhafen 18, 23966 Wismar, Germany

Phone: +49 (0)3841-360-1

Phone: +49 (0)3841-360-200

Fax: +49 (0)3841-360-222

Internet: www.envitec.com

Email: info@envitec.com

Doc. No. 007-05-SpiroQuant_A+_Spec-0

December 2017

Technical information is subject
to change without notice!

© 2017 Honeywell International Inc.

EnviteC by Honeywell reserves the
right to make changes in product
specifications and adjust its production
at any time and without notice.

ENVITEC
by Honeywell