

QY100KH汽车起重机 / Truck Crane

技术规格书

Technical specifications

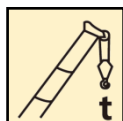

100 t

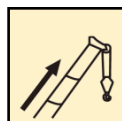

52 m

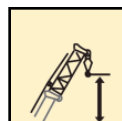

83.5 m



产品特征号：B

Product feature code: B

2024年1月第1版

1st edition, Jan. 2024

目录

Contents

目录	
Contents	
尺寸参数 Dimensions	4
技术规格 Product specifications	5-8
车型与选装件 Version and optional parts	9
重量/作业速度 Weight / Working speeds	10
平衡重 Counterweight	11
运输部件尺寸 Dimension and weight of parts transported	12-13
臂架组合方案 Boom / Jib combinations	14-15
主臂 Boom	16-18
副臂 Jib	19-20
主臂加长节 Boom extension	21-22
符号标识 Description of symbols	23
主要技术参数表 Table of main technical parameters	24-25
注意事项 Notes	26

尺寸参数 Dimensions

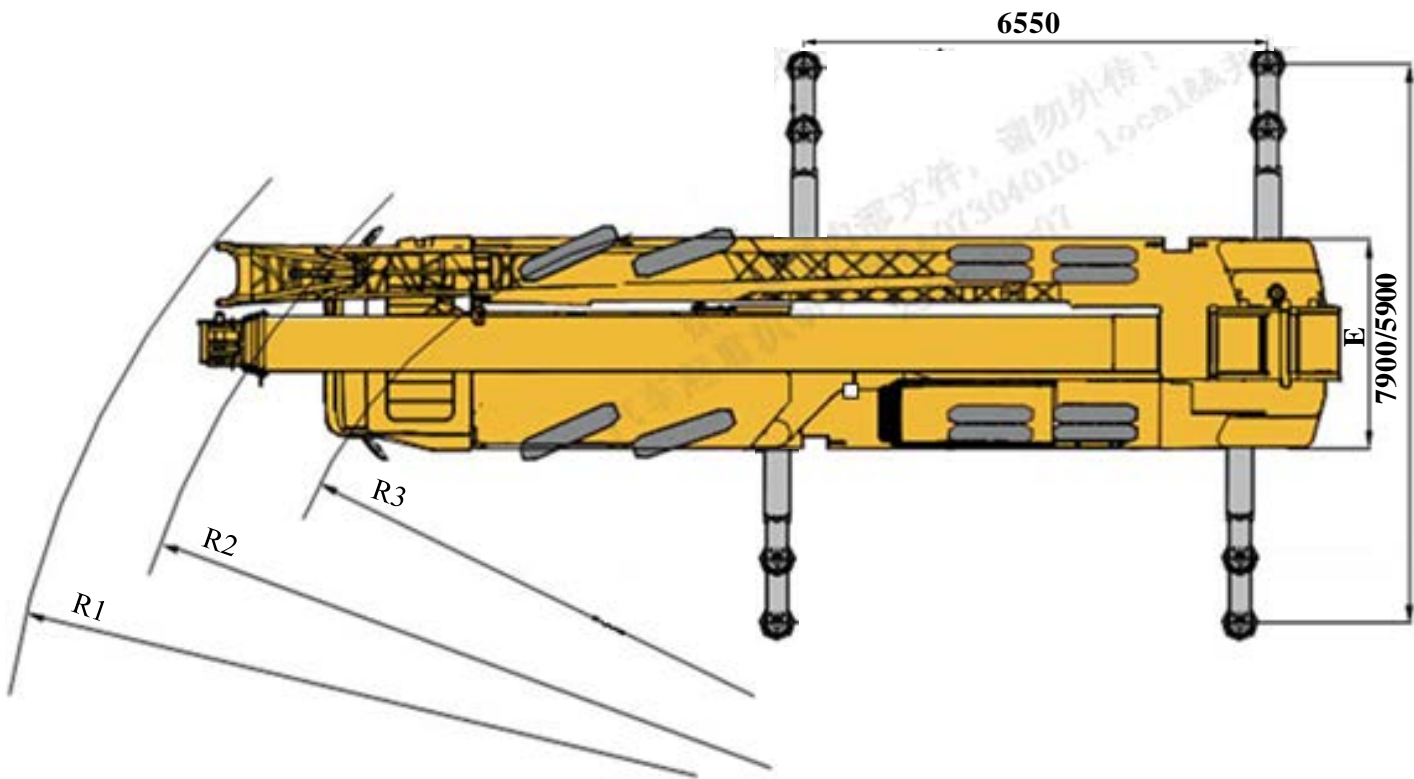
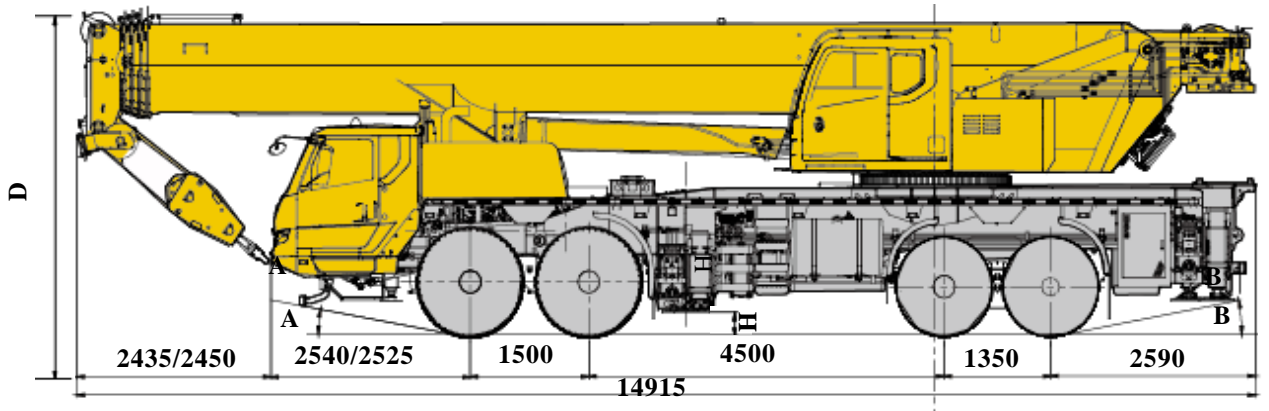

	A	B	D	E	R1	R2	R3	H
385/95R25 (前桥) (Front axles)	11°							
12.00R24、325/95R24 (后桥) (Rear axles)	18° (拆除前防护) (front protective device removed)	11°	3980	2800	14950	14050	12000	260

备注：当配置齐星驾驶室时，前伸:2435mm，前悬为2540mm；当配置徐工汽车驾驶室时，前伸:2450mm，前悬为2525mm。

Remark: Front extension: 2435 mm, front overhang: 2540 mm (equipped with Qixing driver's cab);

Front extension: 2450 mm, front overhang: 2525 mm (equipped with XCMG Automobile driver's cab).

技术规格

Technical specifications

	底盘
车架	徐工设计、制造，全覆盖式走台板，防扭转箱型结构，高强度钢材制造。
支腿	4支腿，H形布置，活动支腿采用双级水平支腿，水平伸缩和垂直伸缩由液压控制，底盘两侧装有支腿操纵杆，水平仪、LED照明灯和调速按钮，支腿油缸均设有单向阀，且垂直支腿带有双向液压锁。 支脚盘尺寸：φ450mm 最大起重量时支腿反力：827KN
发动机	WP10H400E50，直列六缸水冷电控柴油发动机，潍柴制造，额定功率294kW/1900rpm，最大扭矩1900Nm/1200-1300rpm， 最大基准扭矩：2067N.m； 国V排放标准； 尿素箱容积：35L。 燃油箱容积：470L
变速箱	陕齿手动变速箱，10个前进档，2个倒档。
车桥	名牌厂家高强度车桥，1、2桥转向，3、4桥驱动。
悬挂	前悬挂为钢板弹簧，后悬挂为橡胶悬挂。
轮胎	12个轮胎，1个备胎，1、2桥均装单胎，3、4桥均装双胎。轮胎规格：385/95R25（前桥） 12.00R24/325/95R24（后桥）

制动	行车制动：双回路气压制动，作用于所有车轮。 驻车制动：弹簧储能制动，作用于2、3、4轴车轮。 辅助制动：发动机排气制动和缸内缓速制动。
转向	1、2桥机械转向+液压助力。
驾驶室	豪华驾驶室。配置大视野的前挡风安全玻璃、后视镜，电控洗涤器，电子门窗升降器，带有除霜风挡的室内空气加热器，收音机、丝网地垫等。副驾双座椅，可展开为简易卧铺。 2公斤灭火器；标配冷暖空调。
电气系统	直流24伏特，串联12伏特的电池组2个。 发电机: 28伏特-80安培。

技术规格

Technical specifications

	上车
结构	徐工设计、制造，高强度钢材制造。
液压系统	底盘发动机驱动变量柱塞泵，用于起升、变幅、伸缩。负载敏感式比例多路换向阀，带有抗冲击阀、防气蚀阀；风冷式液压油散热器； 液压油箱容积：1206L
操纵方式	液控先导操纵系统，由左右2个操纵手柄控制，由液压泵和比例阀进行液压先导式控制起重机的全部动作
主起升机构	液压控制调速，装有双折线绳槽卷筒，由液压马达通过行星齿轮减速器驱动，内置常闭式制动器并带有平衡阀；
回转机构	四点接触球式回转支承，由液压马达驱动行星齿轮回转机构减速器驱动，可连续回转360°；具有动力控制或自由回转的功能，可无级调速；回转杆设有鸣响开关；
变幅机构	单支双作用前置液压变幅油缸，带有平衡阀
操纵室	新型钢制操纵室，装有无视野死角的前景窗，安全玻璃，车窗装有遮阳板，推拉式车门，电加热座椅靠背可倾斜定位，操纵杆安装在座椅两侧的扶手台上；带推拉踏板；前窗顶窗装有雨刮器；标配冷暖空调
安全装置	液压平衡阀；液压溢流阀；液压双向锁；力矩限制器；三圈保护器，防止钢丝绳过放；臂头设置高度限位，防止钢丝绳过卷；三色报警灯
组合配重	10t 9t 4.8t 1.2t
起重钩	85t钩 55t钩 7t钩

主臂	5节，“U”形截面的筒形焊接结构。双缸绳排伸缩机构 主臂长度：13.29m~52m。
臂端单滑轮	单滑轮，安装在主臂顶端用于单股钢丝绳起重作业，起重性能与主臂相同，但最大起重量不超过6.5t。
固定副臂	2节桁架式焊接结构，具有0°、15°、30°三种固定副臂安装角 固定副臂长度：10.5m/17.5m

技术规格

Technical specifications



Chassis

Frame	Designed and manufactured by XCMG, it is made of high strength steel with fully covered walking surface and anti-torsion box-typed structure.
Outriggers	Four outriggers arranged in H-shape are hydraulically controlled by control levers. Double-stage outrigger beam is adopted. There is an outrigger control station located at each side of the chassis, and there is a level gauge, LED illuminator and two speed buttons on each control station. There is a check valve fitted in each outrigger cylinder, and a double-way hydraulic valve fitted in each jack cylinder. Float dimension: $\phi 450$ mm Reaction force of outrigger at max. lifting load: 827 KN
Engine	WP10H400E50, in-line, 6-cylinder, water cooled, electric control diesel engine, made by WEICHAI, with rated power of 294 kW/1900 rpm and max. torque of 1900 Nm/1000-1400 rpm, Max.reference torque/rpm : 2067 N.m; compliant with China V emission standard; AdBlue tank volume : 35L. Fuel tank capacity: 470 L.
Transmission	Manual transmission, made by Shaanxi Fast Gear Co., Ltd., 10-forward speed and 2-reverse speed.
Alxes	High strength axles, made by famous manufacturers. 1st and 2nd axles are for steering, and 3rd and 4th axles are for driving.
Suspension	Leaf spring suspension is used as front suspension, and rubber suspension is used as rear suspension.

Tires	12 tires and 1 spare tire, 1st and 2nd axles are equipped with single tire, 3rd and 4th axles are equipped with double-tire. Tire specifications:385/95R25 (front axles) 12.00R24/325/95R24 (rear axles)
Braking	Service brake: double-circuit air pressure brake acting on all wheels. Parking brake: spring-loaded brake, acting on the wheels of axles 2, 3 and 4. Auxiliary brake: engine exhaust brake and engine retarder brake.
Steering	Mechanical steering mechanism with a hydraulic booster for 1st and 2nd axles.
Driver's cab	Deluxe driver's cab is equipped with a windshield offering outstanding visibility, rearview mirror, electric wiper-washer, electrically operated window glass lifter, air heater with defrosting function, radio player and floor mat, etc. The co-driver's seat may be changed into a simple sleeper. A fire extinguisher of 2 kg is available. Heater and air conditioner are standard.
Electrical system	24V DC, two sets of 12 V battery in series. Generator: 28 V-80 A.

技术规格

Technical specifications



Superstructure

Frame	Designed and manufactured by XCMG, made of high strength steel.
Hydraulic system	Variable pump driven by chassis engine, used for hoisting, luffing and telescoping operation. Load sensitive proportional multi-way change valve controlled by pilot hydraulic oil, which is integrated with impact resistance valve and cavitation-proof valve; air-cooled hydraulic oil radiator. Tank capacity: 1206 L
Control system	Pilot hydraulic control is used for controlling the superstructure. All crane movements are controlled by hydraulic pump and proportional valve through two control levers on left and right sides.
Main winch system	Hydraulic control is used for speed regulation. The system is driven by a hydraulic motor through a planetary gear reducer, with a normally closed brake, a balance valve and a grooved drum equipped.
Slewing system	Four-point contact-ball slewing ring is driven by the planetary gear reducer of slewing mechanism, which is driven by a hydraulic motor, and may continuously slew 360°. Power control and free slewing function as well as stepless speed regulation are available. There is a horn switch fitted on the slewing control lever.
Luffing system	A front support double-acting hydraulic cylinder is equipped for luffing operation, with a balance valve fitted.
Operator's cab	New steel cab with a full-view windshield, safety glass, sun shield and adjustable operator's seat. Windshield wiper and roof window wiper are fitted. Crane control levers are integrated into armrests. A sliding door and a pull-out step are designed for easy and safe access to the cab. Air conditioning and heater are standard.
Safety devices	Hydraulic balance valve, hydraulic relief valve, double-way hydraulic valve, LMI, lowering limiter for preventing wire rope from over-releasing, anti-two block at boom head for preventing wire rope from over-winding and tri colored light bar. Anemometer
Combined counterweight	10 t 9 t 4.8 t 1.2 t
Hook block	85 t 55 t 7 t

Boom	5-section boom with U cross-section, welding structure. Double-cylinder plus ropes telescoping system. Boom length: 13.29 m~52 m.
Single top	Installed at boom head, used for single line operation. Its lifting performance is the same as that for boom, but the max. lifting load does not exceed 6.5 t.
Fixed jib	Two-section lattice jib, welded structure. Three offset angles of 0°, 15° and 30°. Fixed jib length: 10.5 m/17.5 m.

车型与选装件

Version and optional parts

车型 Version	功能描述 Function description	选择 Selection
标准型 Standard	五节主臂52m，固定副臂17.5m 5-section boom of 52 m, fixed jib of 17.5 m	

注释：该产品仅标准型一种车型。

Note: only the standard version is available.

可选装件 Optional parts		选择 Selection
平衡重 Counterweight	8t平衡重（4t+4t，共两块） 8 t (4 t + 4 t, two slabs)	
加长节 Boom extension	7m加长节（2件） Extension of 7m (2 sections)	
独立臂头 Independent jib head	2.9m独立臂头 Independent jib head of 2.9 m	

重量 Weight



Axle	1	2	3	4	总重量 Total weight
t	12	12	12.9	12.9	49.8 ¹⁾
t	13	13	25	25	76 ²⁾

1) 行驶状态：上车不带85t钩、副臂、加长节总成、副卷（含钢丝绳）、活动平衡重；下车不带备胎及备胎支架；
In travel configuration: 85t Hook block, Jib, boom extension assembly, auxiliary winch (wire rope included) and removable counterweight slabs are excluded for the superstructure. Spare tire and spare tire bracket are excluded for the chassis.

2) 短途转场状态：最高车速10km/h，带55t钩、带7t钩、副臂、副卷，25t平衡重，备胎及备胎支架；转向驱动形式8×4×4；轮胎规格：1、2轴：385/95R25，3、4轴：12.00R24或325/95R24；
Short-distance job site transfer: max. travel speed is 10 km/h, carry the 55 t hook block, 7 t hook block, jib, auxiliary winch, 25 t counterweight, spare tire and its bracket on board. Steer & Driving type: 8×4×4; Tire specification: 1st and 2nd axes: 385/95R25, 3rd and 4th axes: 12.00R24 or 325/95R24.



吊钩 Hook block	倍率 Parts of line	吊钩重量 Weight (kg)	吊钩尺寸 Dimensions (mm)	备注 Remarks
85 t	13	700	1735×554×520	单钩 Single hook
55 t	8	470	1600×520×370	单钩 Single hook
7 t	1	210	717×370×370	单钩 Single hook

作业速度 Working speeds



385/95R25 (前桥) (Front axles)
12.00R24, 325/95R24 (后桥) (Rear axles)

2.5 ~ 80

47%



作业机构 Operation mechanism	作业速度 Working speed	最大单绳拉力 Max. single line pull	钢丝绳直径/长度 Rope diameter/ length
	0-130 m/min, 单绳, 第四层 m/min, single line, 4th layer	65.7 kN	20 mm/280 m
	0-90 m/min, 单绳, 第四层 m/min, single line, 4th layer	65.7 kN	20 mm/200 m
	0-1.4 r/min		
	从-0.6°抬起至80.3°约65s Approx. 65 s for boom luffing from -0.6° to 80.3°		
	从13.29m伸出至52m约150s Approx. 150 s for boom extending from 13.29 m to 52 m		

平衡重 Counterweight

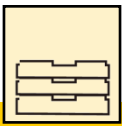
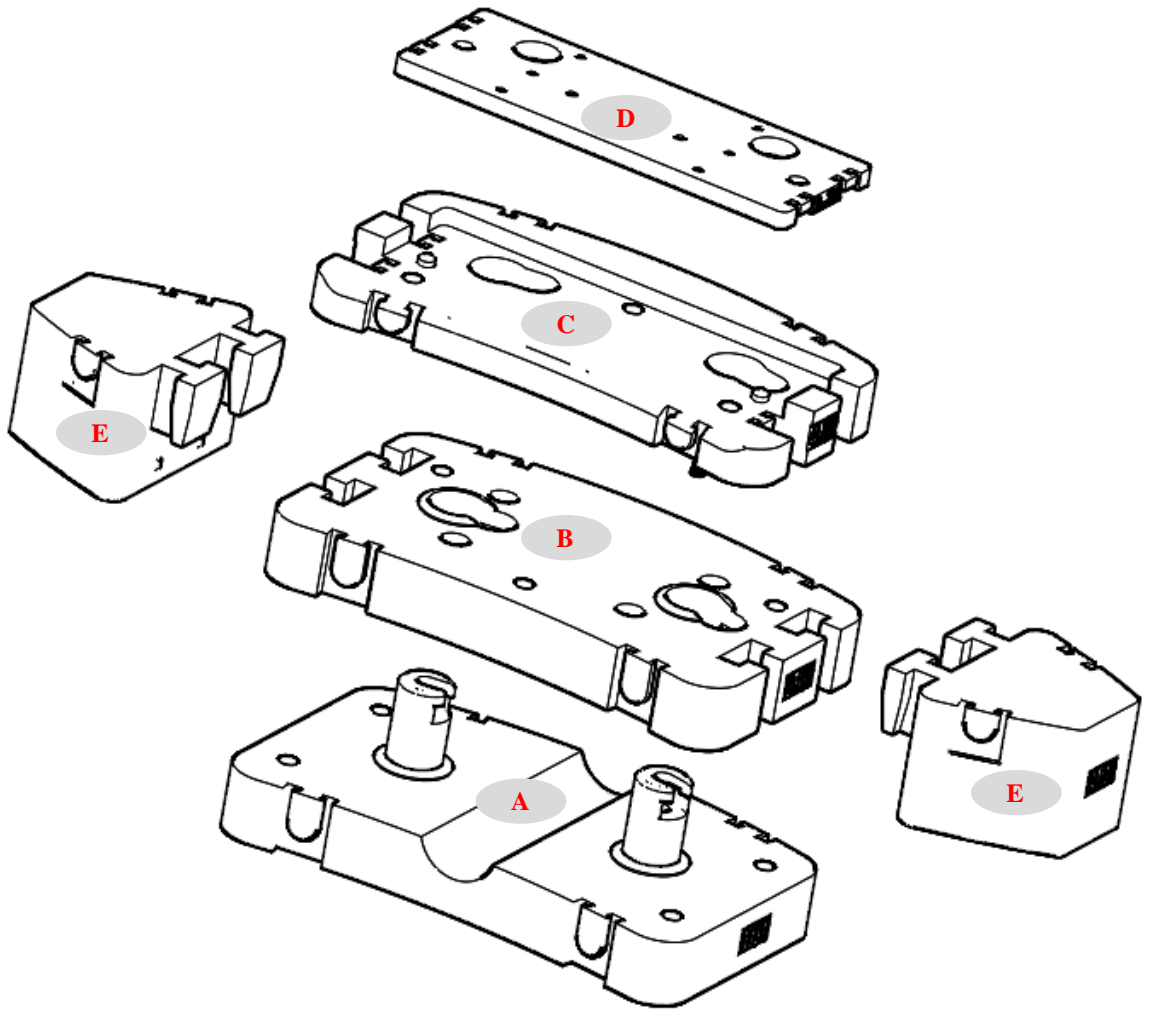

平衡重 Counterweight	A	B	C	D	E (选装) (Optional)
尺寸 (长×宽×高) mm Dimensions (L×W×H) (mm)	2740×1661×815	2740×1661×380	2740×1396×305	2340×858×94	1080×1252×710
重量 t Weight (t)	10 t	9 t	4.8 t	1.2 t	4 t

工况模式 Working mode	1.2 t	6 t	11.2 t	16 t	20.2t	25 t	33 t
组合形式 Combinations	D	C+D	A+D	A+C+D	A+B+D	A+B+C+D	A+B+C+D+2 E

运输部件尺寸

Dimension and weight of parts transported

独立臂头 455kg
Independent jib head 455 kg

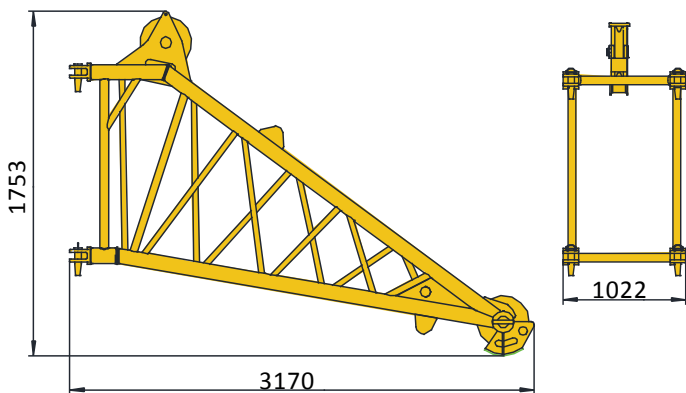

备胎 (含支架) 300kg
Spare tire (bracket included) 300 kg

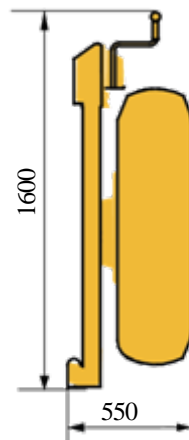

副起升机构(含钢丝绳) 1060kg
Auxiliary winch (wire rope included) 1,060 kg

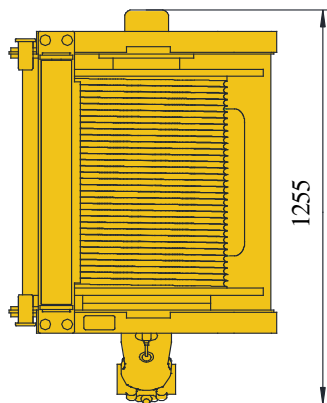
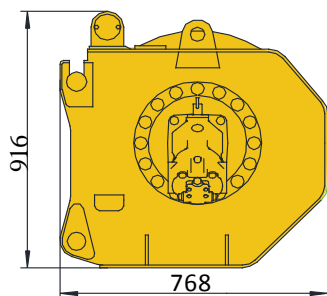

运输部件尺寸

Dimension and weight of parts transported

副臂及支架 1150kg
Jib and the bracket 1,150 kg

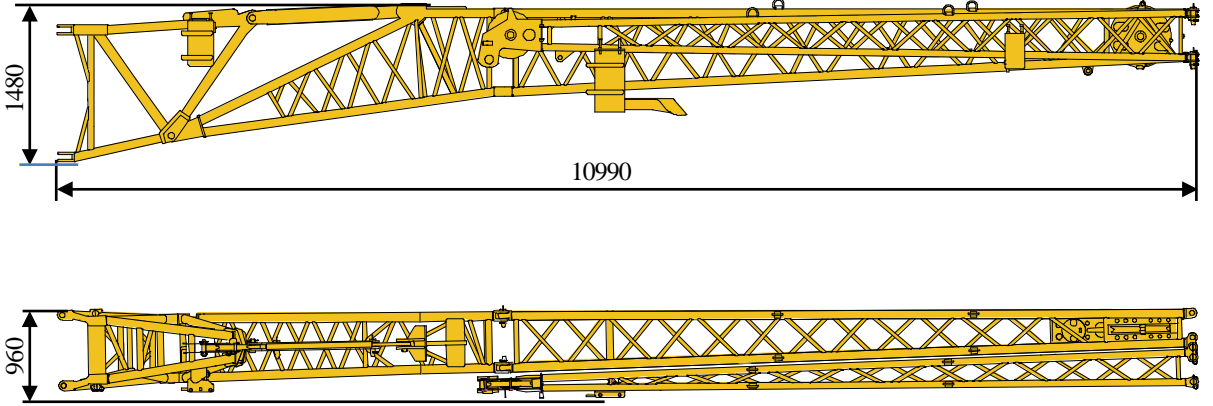

主臂加长节 466kg
Boom extension 466 kg

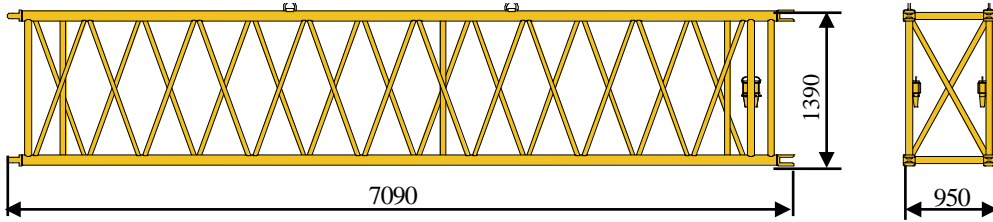

起重钩 700kg
Hook block 700 kg

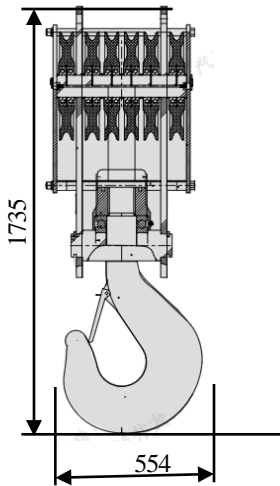

85t钩
85 t hook block

臂架组合方案

Boom/ Jib combinations

副臂 – 10.5 m
Jib – 10.5 m



副臂 – 17.5 m
Jib – 17.5 m

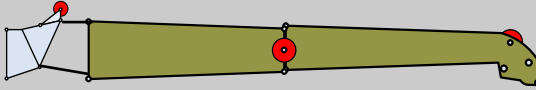



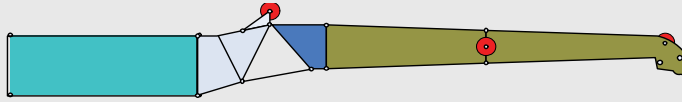

主臂加长节 – 24.5m
Boom extension – 24.5 m

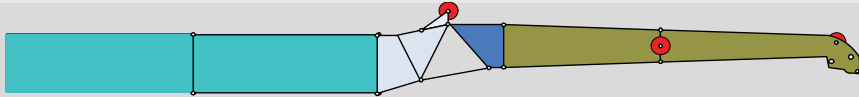

主臂加长节 – 31.5 m
Boom extension – 31.5 m



部件 Parts	结构形式 Structure	尺寸 (长×宽×高) mm Dimensions (L×W×H) (mm)	重量 kg Weight (kg)
连接架 Connection bracket		2035×950×1470	235
主臂加长节 Boom extension		7090×950×1390	466
一节副臂总成 1st jib section assembly		9923×1106×790	578
二节副臂总成 2nd jib section assembly		6908×608×446	265

臂架组合方案

Boom / Jib combinations

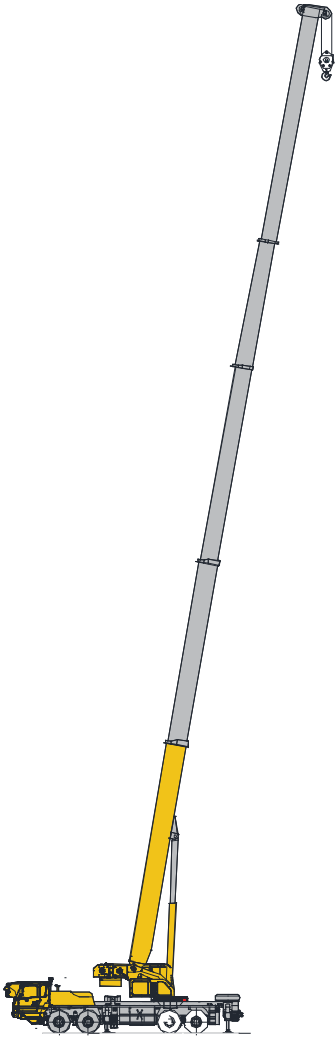

主臂
Telescopic boom

T : 13.29~52 m

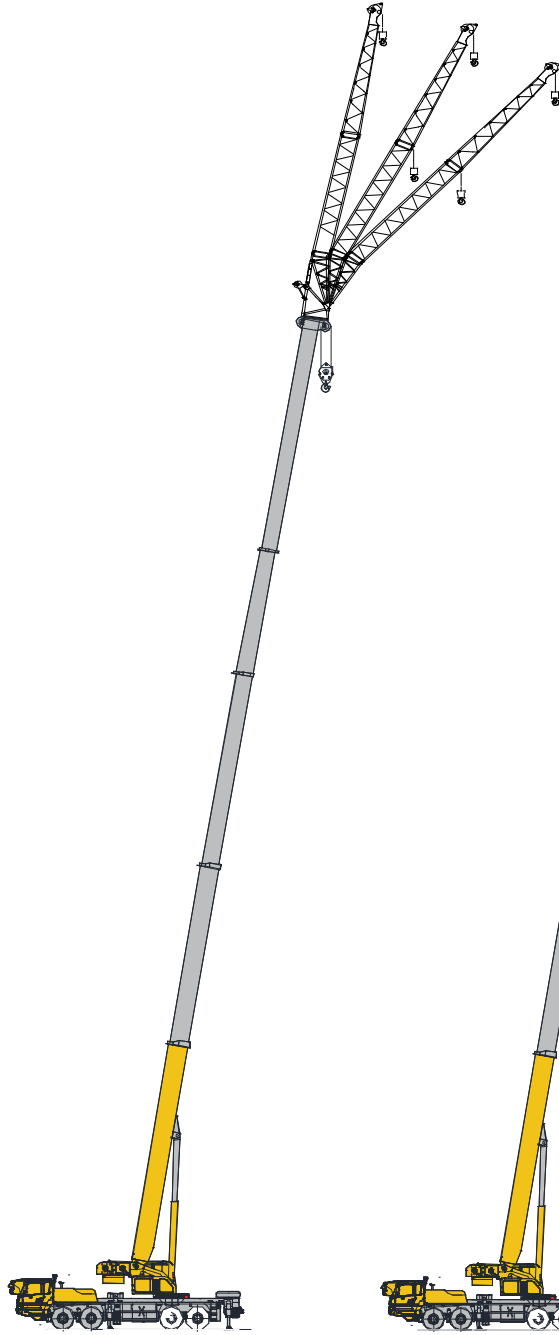

副臂
Jib

T : 52 m
J : 10.5~17.5 m



主臂加长节
Boom extension

T : 52 m
I : 7 m/14 m
J : 10.5~17.5 m

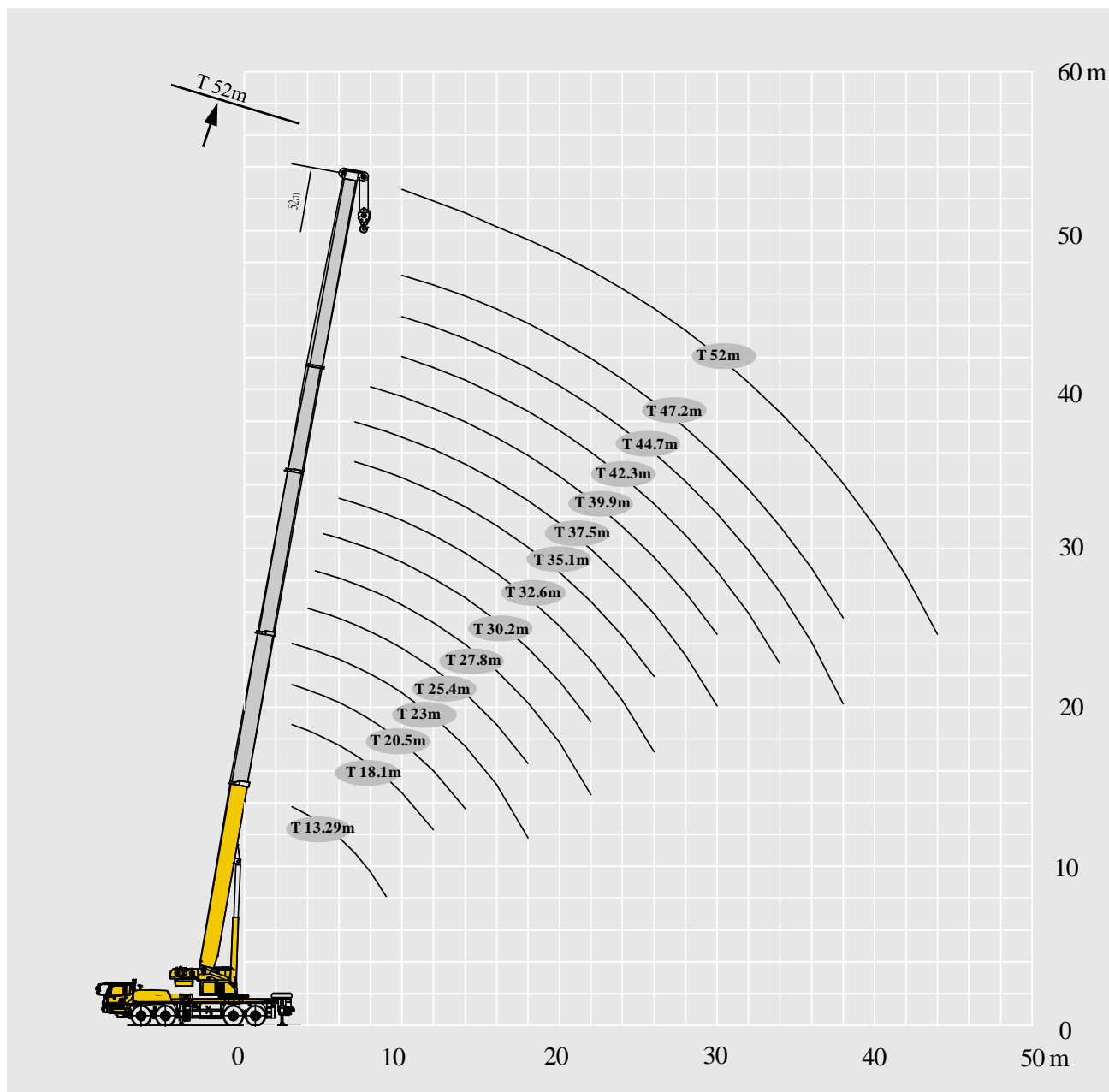

起重性能表

Lifting load tables

T 13.29~52 m

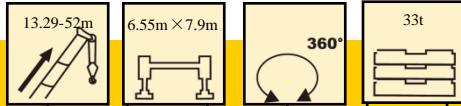

	13.29	18.1	20.5	23.0	25.4	27.8	30.2	32.6	35.1	37.5	39.9	42.3	44.7	47.2	52.0	
3	100.0*	78.0	46.0													3
3.5	83.0	78.0	46.0	58.0												3.5
4	82.0	78.0	46.0	58.0	45.0											4
4.5	78.0	78.0	46.0	58.0	45.0											4.5
5	70.0	70.0	46.0	58.0	45.0	41.0	42.0									5
6	59.0	59.0	46.0	51.2	45.0	41.0	42.0	42.0								6
7	50.0	50.0	46.0	45.6	45.0	41.0	38.0	42.0	22.5	32.2						7
8	44.0	44.0	44.0	41.0	44.0	41.0	33.9	42.0	22.5	29.5	22.0					8
9	39.0	39.0	39.0	37.0	39.0	39.0	30.8	39.0	22.5	27.0	22.0					9
10		34.0	35.4	33.6	35.0	35.4	28.0	35.4	22.3	24.9	22.0	18.2	21.3	17.9	16.5	10
12		27.0	28.0	27.0	28.0	29.5	23.9	29.5	20.1	21.4	21.0	16.4	18.7	16.3	15.4	12
14			24.0	21.7	23.0	24.7	20.6	24.6	18.2	18.4	19.2	15.0	16.3	14.9	14.3	14
16				16.8	18.8	20.8	17.9	20.2	16.6	16.0	17.6	13.7	14.3	13.6	13.1	16
18				13.7	15.4	17.1	14.7	16.6	15.1	14.2	16.3	12.6	12.8	12.4	11.7	18
20						14.7	12.1	13.9	13.7	12.7	14.4	11.2	11.5	11.2	10.5	20
22						12.5	10.3	11.7	12.6	11.2	12.2	10.4	10.2	10.4	9.5	22
24								10.0	11.2	9.5	10.5	9.7	9.2	9.6	8.6	24
26								8.6	9.8	8.0	9.1	8.9	8.3	8.9	7.8	26
28										6.9	7.9	8.2	7.4	8.2	7.1	28
30										5.9	6.9	7.7	6.4	7.2	6.4	30
32												6.9	5.6	6.3	5.9	32
34												6.2	4.8	5.6	5.1	34
36													4.1	4.9	4.5	36
38													3.5	4.3	3.9	38
40															3.4	40
42															2.9	42
44															2.5	44
倍率 n	13	13	8	10	8	7	7	7	4	6	4	4	4	4	3	倍率 n
二节臂 2nd	0%	50%	0%	100%	50%	0%	100%	50%	0%	100%	50%	0%	100%	50%	100%	二节臂 2nd
三节臂 3rd	0%	0%	25%	0%	25%	50%	25%	50%	75%	50%	75%	100%	75%	100%	100%	三节臂 3rd
四节臂 4th	0%	0%	25%	0%	25%	50%	25%	50%	75%	50%	75%	100%	75%	100%	100%	四节臂 4th
五节臂 5th	0%	0%	25%	0%	25%	50%	25%	50%	75%	50%	75%	100%	75%	100%	100%	五节臂 5th

说明：*为名义载荷，表示起重机能力等级
 Note：* means capacity class

起重性能表

Lifting load tables

T 13.29~52 m

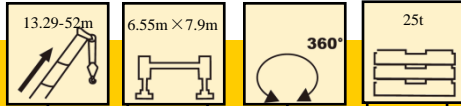

	13.29	18.1	20.5	23.0	25.4	27.8	30.2	32.6	35.1	37.5	39.9	42.3	44.7	47.2	52.0	
3	100.0*	78.0	46.0													3
3.5	83.0	78.0	46.0	58.0												3.5
4	82.0	78.0	46.0	58.0	45.0											4
4.5	78.0	78.0	46.0	58.0	45.0											4.5
5	70.0	70.0	46.0	58.0	45.0	41.0	42.0									5
6	59.0	59.0	46.0	51.2	45.0	41.0	42.0	42.0								6
7	50.0	50.0	46.0	45.6	45.0	41.0	38.0	42.0	22.5	32.2						7
8	44.0	44.0	44.0	41.0	44.0	41.0	33.9	42.0	22.5	29.5	22.0					8
9	37.2	36.3	39.0	35.7	38.1	39.0	30.8	39.0	22.5	27.0	22.0					9
10		29.8	32.5	29.2	31.5	33.3	28.0	32.4	22.3	24.9	22.0	18.2	21.3	17.9	16.5	10
12		21.3	23.7	20.8	22.9	24.5	22.3	23.7	20.1	21.4	21.0	16.4	18.7	16.3	15.4	12
14			18.4	15.6	17.5	19.0	16.9	18.3	18.2	17.7	18.8	15.0	16.3	14.9	14.3	14
16				12.0	13.8	15.3	13.3	14.5	15.6	14.0	15.0	13.7	14.3	13.6	13.1	16
18				9.4	11.1	12.6	10.6	11.9	12.9	11.4	12.3	12.6	11.8	12.4	11.7	18
20						10.5	8.6	9.9	10.9	9.4	10.3	11.1	9.8	10.5	10.1	20
22						8.9	7.1	8.2	9.3	7.7	8.7	9.4	8.2	8.9	8.5	22
24								6.9	7.9	6.5	7.3	8.2	6.9	7.7	7.2	24
26								5.9	6.9	5.4	6.3	7.1	5.9	6.5	6.2	26
28										4.5	5.4	6.2	4.9	5.7	5.3	28
30										3.7	4.6	5.4	4.2	4.9	4.5	30
32												4.8	3.6	4.3	3.8	32
34												4.2	3.0	3.7	3.3	34
36													2.5	3.1	2.8	36
38													2.0	2.7	2.4	38
40															2.0	40
42															1.6	42
44															1.3	44
倍率 n	13	13	8	10	8	7	7	7	4	6	4	4	4	4	3	倍率 n
二节臂 2nd	0%	50%	0%	100%	50%	0%	100%	50%	0%	100%	50%	0%	100%	50%	100%	二节臂 2nd
三节臂 3rd	0%	0%	25%	0%	25%	50%	25%	50%	75%	50%	75%	100%	75%	100%	100%	三节臂 3rd
四节臂 4th	0%	0%	25%	0%	25%	50%	25%	50%	75%	50%	75%	100%	75%	100%	100%	四节臂 4th
五节臂 5th	0%	0%	25%	0%	25%	50%	25%	50%	75%	50%	75%	100%	75%	100%	100%	五节臂 5th

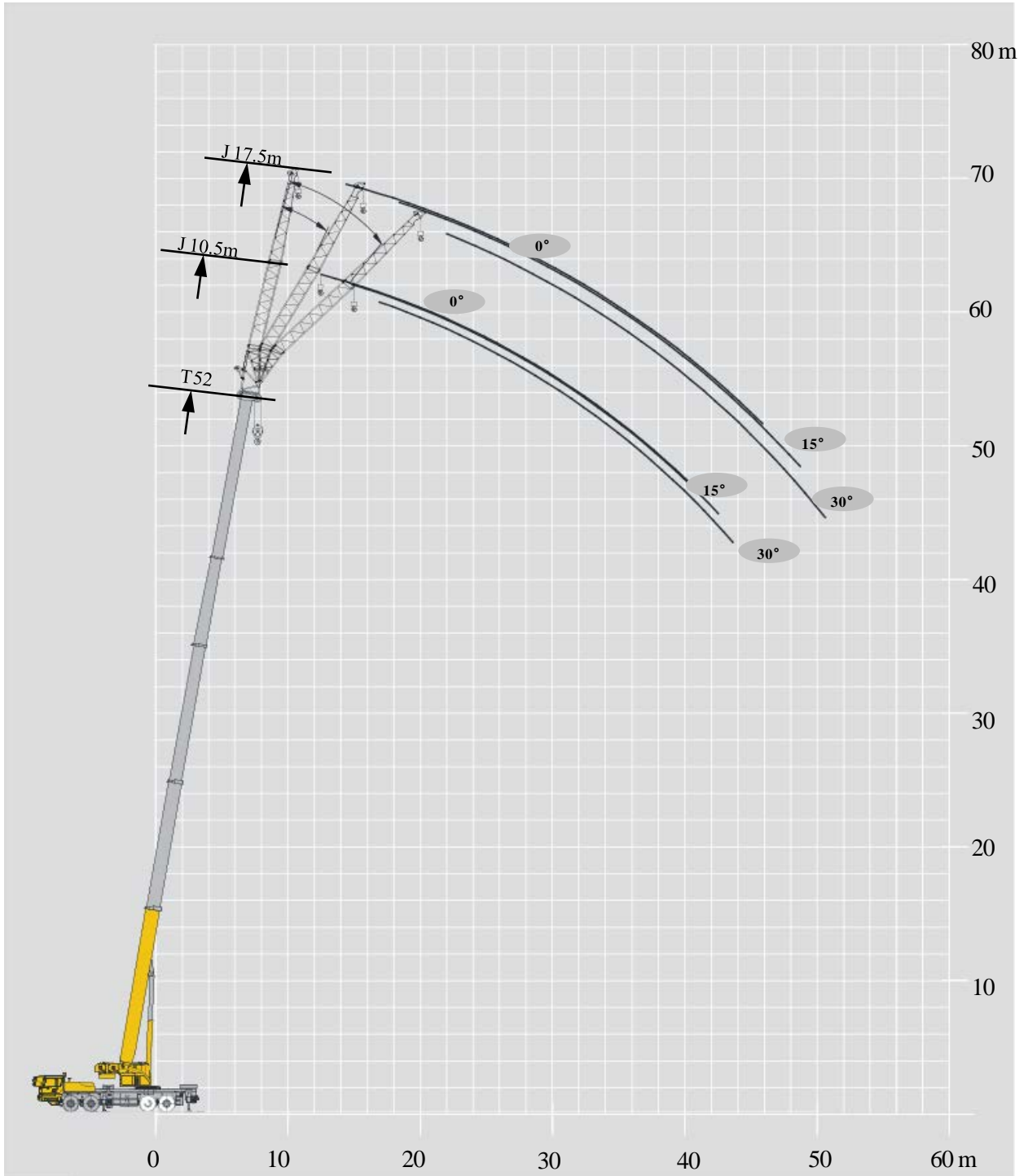

说明：*为名义载荷，表示起重机能力等级
 Note：* means capacity class





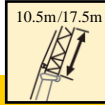
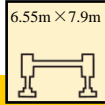

起重性能表

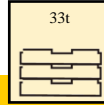
Lifting load tables

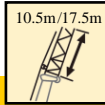
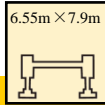
J 10.5 m/17.5 m

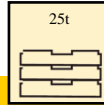
	    						
	10.5m			17.5m			
	0°	15°	30°	0°	15°	30°	
80	6.5	6.5	4.7	5.1	3.8	2.6	80
78	6.5	6.5	4.8	4.9	3.6	2.5	78
75	6.5	6.4	4.8	4.5	3.4	2.3	75
72	6.5	6.2	4.7	4.3	3.3	2.2	72
70	6.5	5.9	4.5	4.1	3.2	2.1	70
65	6.1	5.4	4.1	3.6	3.0	2.0	65
60	5.3	5.1	3.9	3.3	2.8	1.8	60
55	4.1	4.4	3.7	3.0	2.6	1.7	55
50	3.4	3.6	3.5	2.8	2.5	1.7	50

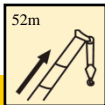
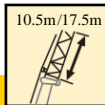
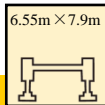
	    						
	10.5m			17.5m			
	0°	15°	30°	0°	15°	30°	
80	6.5	6.5	4.7	5.1	3.8	2.6	80
78	6.5	6.5	4.8	4.9	3.6	2.5	78
75	6.5	6.4	4.8	4.5	3.4	2.3	75
72	6.5	6.2	4.7	4.3	3.3	2.2	72
70	6.5	5.9	4.5	4.1	3.2	2.1	70
65	5.4	5.1	4.1	3.6	3.0	2.0	65
60	4.2	3.9	3.7	3.3	2.8	1.8	60
55	2.8	2.7	2.6	2.4	2.2	1.7	55
50	2.2	2.1	2.0	1.8	1.7	1.6	50

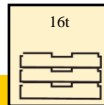
	    						
	10.5m			17.5m			
	0°	15°	30°	0°	15°	30°	
80	6.5	6.5	4.7	5.1	3.8	2.6	80
78	6.5	6.5	4.8	4.9	3.6	2.5	78
75	6.5	6.4	4.8	4.5	3.4	2.3	75
72	6.5	6.2	4.7	4.3	3.3	2.2	72
70	6.4	5.8	4.5	4.1	3.2	2.1	70
65	3.8	3.6	3.4	3.2	2.9	2.0	65
60	2.8	2.6	2.5	2.3	2.0	1.8	60
55	1.6	1.5	1.4	1.3	1.2	1.1	55
50	1.0	1.0					50

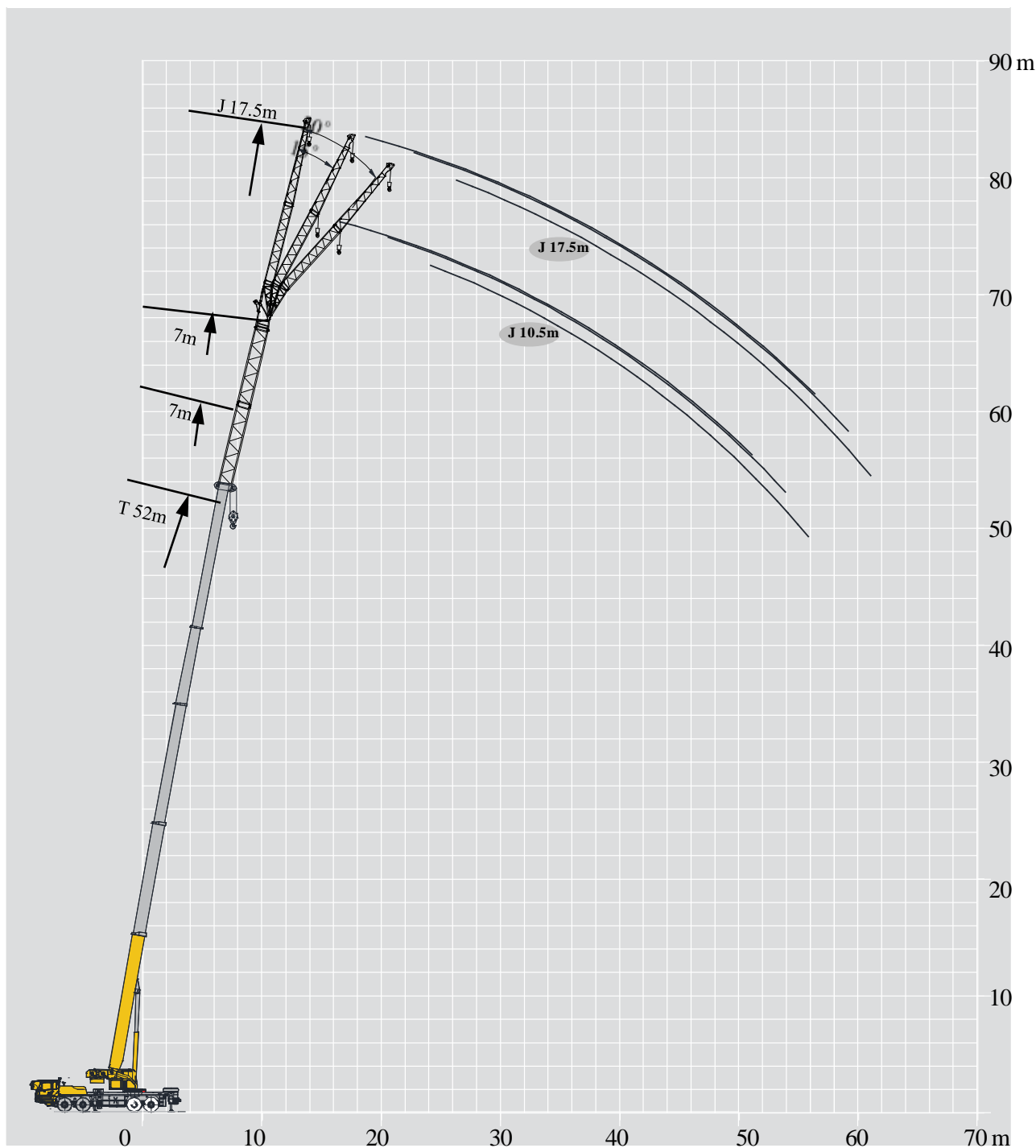

起重性能表

Lifting load tables

I 7 m

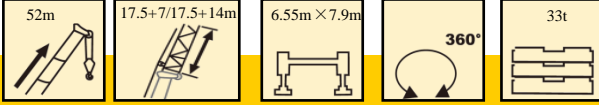

	52m+17.5m						
	7m			14m			
	0°	15°	30°	0°	15°	30°	
80	3.1	2.7	1.7	2.7	2.7	1.7	80
78	3.1	2.6	1.7	2.7	2.6	1.7	78
75	3.1	2.5	1.6	2.7	2.4	1.6	75
72	3.1	2.3	1.5	2.6	2.3	1.5	72
70	3.1	2.2	1.4	2.7	2.2	1.4	70
65	3.0	1.9	1.3	2.6	1.9	1.3	65
60	2.7	1.7	1.2	2.5	1.7	1.2	60
55	2.4	1.6	1.1	2.2	1.6	1.1	55
50	2.2	1.5	1.0	1.7	1.4	1.1	50

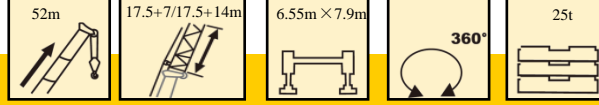

	52m+17.5m						
	7m			14m			
	0°	15°	30°	0°	15°	30°	
80	3.1	2.7	1.7	2.7	2.7	1.7	80
78	3.1	2.6	1.7	2.7	2.6	1.7	78
75	3.1	2.5	1.6	2.7	2.4	1.6	75
72	3.1	2.3	1.5	2.6	2.3	1.5	72
70	3.1	2.2	1.4	2.7	2.2	1.4	70
65	3.0	1.9	1.3	2.6	1.9	1.3	65
60	2.7	1.7	1.2	2.3	1.7	1.2	60
55	1.8	1.6	1.1	1.4	1.3	1.1	55
50	1.3	1.2	1.0				50

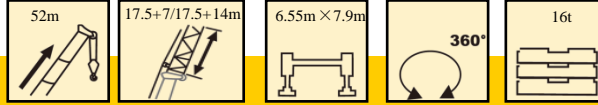

	52m+17.5m						
	7m			14m			
	0°	15°	30°	0°	15°	30°	
80	3.1	2.7	1.7	2.7	2.7	1.7	80
78	3.1	2.6	1.7	2.7	2.6	1.7	78
75	3.1	2.5	1.6	2.7	2.4	1.6	75
72	3.1	2.3	1.5	2.6	2.3	1.5	72
70	3.1	2.2	1.4	2.7	2.2	1.4	70
65	2.5	1.9	1.3	2.0	1.9	1.3	65
60	1.7	1.5	1.2	1.3	1.2	1.1	60

符号标识

Description of symbols

常规标识

General symbols

	上车 Superstructure		底盘 Chassis
	起重能力 Lifting capacity		车桥 Axle
	吊臂长度 Boom length		行驶速度 Travel speed
	工作幅度 Radius		爬坡能力 Grade ability
	吊臂仰角 Boom angle		轮胎 Tires
	主臂起升高度 Hoist height with boom		支腿 Outriggers
	固定副臂长度 Fixed jib length		吊钩 Hook block
	副臂安装角 Jib offset angle		平衡重 Counterweight
	副臂起升高度 Hoist height with jib		卷扬 Winch
	主臂加长节 Boom extension		360°全回转 360° rotation
	带载行驶 Travel with load		

主要技术参数表

Table of main technical parameters

类别 Category	项目 Item	单位 Unit	参数 Parameter	
尺寸参数 Dimensions	外形尺寸 (长×宽×高) Dimensions (length×width×height)	mm	14915×2800×3980	
	轴距 Wheelbase	mm	1500+4500+1350	
	轮距 (前/后) Track (Front/ Rear)	mm	2400/2400/2063/2063	
	前悬/后悬 Front/ Rear overhang	mm	2540 (齐星Qixing)、2525 (徐工汽车XCMG Automobile)/2590	
	前伸/后伸 Front/ Rear extension	mm	2435(齐星Qixing)、2450(徐工汽车XCMG Automobile)/0	
重量参数 Weight	最大允许总质量 Max. permissible weight	kg	49800	
	轴荷 Axle load	一轴 1st axle	kg	12000
		二轴 2nd axle	kg	12000
		三轴 3rd axle	kg	12900
		四轴 4th axle	kg	12900
动力参数 Power	发动机型号 Engine model	—	WP10H400E50	
	额定功率/转速 Engine rated power/rpm	kW/(r/min)	294/1900	
	最大净功率/转速 Max. net power/rpm	kW/(r/min)	289/1900	
	最大输出扭矩/转速 Max. output torque/rpm	N.m/(r/min)	1900/ 1200-1300	
行驶参数 Travel	最高车速 Max. travel speed	km/h	≥80	
	最低稳定车速 Min. stable travel speed	km/h	2.5 ~ 3	
	最小转弯直径 Min. turning diameter	m	≤24	
	臂头最小转弯直径 Min. turning diameter at boom tip	m	≤30	
	最小离地间隙 Min. ground clearance	mm	260	
	接近角 Approach angle	°	11 (18拆除前防护) (Front protective device removed)	
	离去角 Departure angle	°	11	
	制动距离 (制动初速度为30km/h) Braking distance (at 30 km/h)	m	≤10	
	最大爬坡能力 Max. grade ability	%	47	
	百公里油耗 Fuel consumption per 100 km	L	44	
噪音 Noise	加速行驶机外噪声 Exterior noise level	dB(A)	≤84	
	驾驶员耳旁噪声 Noise level at seated position	dB(A)	≤90	

主要技术参数表

Table of main technical parameters

类别 Category	项目 Item		单位 Unit	参数 Parameter	
主要性能参数 Main performance	最大额定总起重量 Max. total rated lifting capacity		t	100*	
	最小额定工作幅度 Min. rated working radius		m	3	
	转台尾部回转半径 Turning radius at turntable tail	平衡重处 Counterweight	mm	4665	
		副卷处 Auxiliary winch	mm	4682	
	最大起重力矩 Max. load moment	基本臂 Base boom	kN.m	3469	
		最长主臂 Fully-extended boom	kN.m	2065	
		最长主臂+副臂 Fully-extended boom + Jib	kN.m	1096	
	支腿跨距 Outrigger span	纵向 Longitudinal	m	6.55	
		横向 Lateral	m	7.9 (5.9)	
	起升高度 Hoist height	基本臂 Base boom	m	13.7	
		最长主臂 Fully-extended boom	m	52.2	
		最长主臂+副臂 Fully-extended boom + Jib	m	83.5	
	起重臂长度 Boom length	基本臂 Base boom	m	13.29	
		最长主臂 Fully-extended boom	m	52	
		最长主臂+副臂 Fully-extended boom + Jib	m	83.5	
副臂安装角 Jib offset angle		°	0、15、30		
工作速度参数 Working speed	起重臂起臂时间 Boom raising time		s	≤65	
	起重臂全伸时间 Boom fully extended time		s	≤150	
	最大回转速度 Max. slewing speed		r/min	≥1.4	
	支腿收放时间 Time for extending and retracting outriggers	水平支腿 Outrigger beam	收 Retracting	s	≤30
			放 Extending	s	≤40
		垂直支腿 Outrigger jack	收 Retracting	s	≤40
			放 Extending	s	≤50
起升速度 (单绳,第四层,空载) Hoisting speed(single line, 4th layer, no load)	主起升机构 Main winch		m/min	≥130	
	副起升机构 Auxiliary winch		m/min	≥90	
噪声 Noise	机外辐射 Exterior noise level		dB (A)	≤124	
	司机位置处 Noise level at seated position		dB (A)	≤90	

注意事项

Notes

1. 表中额定总起重量值，是在平整的坚固地面上本起重机能够保证的最大总起重量，包括吊钩和吊具的重量，所以为了估算重物重量，必须减去上述的装置重量。
2. 表中的工作幅度为起吊重物离地时起重物到起重机回转轴线的水平距离，是包括起重臂变形量在内的实际值，因而起吊前应考虑起重臂变形量。
3. 只允许在5级(瞬时风速14.1m/s，风压125N/m²)风以下进行作业。
4. 吊重前操作者必须对物体的重量和工作范围了解后选择合适的作业工况，严禁超出表中的数值。幅度及臂长在相邻两个数值之间时，应依据两个数值中较小值确定起重作业。
5. 应按主臂仰角范围作业，即使是空载，也不应使主臂仰角处于范围外，谨防整机倾翻。
6. 表中的主臂长度应要按照每节臂的伸缩要求进行伸出。

1. The total rated load given in the rated load charts are the maximum lifting capacity when the crane is set up on firm and level ground. The total rated load includes the weight of the hook block and slings. The weight of above-mentioned devices should be deducted from the rated lifting load.
2. The working radius shown in the rated load charts is the radius when the load is lifted off the ground, and it is the actual value including loaded boom deflection. Take boom deflection into consideration before beginning a lifting operation.
3. A lifting operation is permissible only when the wind force is below grade 5 (instantaneous wind speed is 14.1 m/s, wind pressure is 125 N/m²).
4. Before beginning lifting operation, the operator should know the weight of the load to be lifted and its working range, and then select proper working conditions. Never operate the crane beyond the limit shown in the chart. Use the lower value from the chart when the boom length or working radius is between the range of values.
5. Do not extend the boom into areas of the load chart where the crane does not have capacity beyond the angles shown in the range diagrams, or tipping may occur.
6. The boom should be extended according to the telescoping code shown by digits, which means the percentage of boom sections extended.



地址：江苏省徐州市经济技术开发区高新路68号

Add : No. 68 Gaoxin Road, Economic and Technological
Development Zone, Xuzhou, Jiangsu, China

电话(Tel) : +86-516-83462242/83462350

质量监督电话(Quality Inquiry Tel) : +86-516-87888268

备件电话(Spare Parts Tel) : +86-516-83461542

邮编(Post Code) : 221004

网址(Web) : <http://www.xcmg.com>

服务热线 Service Tel

400-110-9999



本印刷品不属于合同。出于产品不断改进的需要，我们保留对产品型号、参数、配置进行变更的权利，恕不另行通知。图片仅供参考，具体产品以实物为准。图片中产品可能并非标准配置，部分部件可能需要另行购置。办理牌照和上路行驶需遵守当地法规。

This print does not belong to the contract. We reserve the right to modify the design (such as product model, parameters and configuration) without notice for improvement. The pictures are just for reference. The product in the picture may not be standard configuration. Some parts need to be purchased separately. Conform to the local laws for license application and road traveling.

XCMG—QY100KH