

Artis zee

Maintenance Instructions System

Artis zee Biplane Maintenance (e)

Also applicable for Artis zee biplane MN, Artis zee III biplane, Artis zee III biplan MN
The protocol AXA4-070.832.02.11.XX is required for these instructions

Document Version

Siemens Healthcare GmbH reserves the right to change its products and services at any time.

In addition, manuals are subject to change without notice. The hardcopy documents correspond to the version at the time of system delivery and/or printout. Versions to hardcopy documentation are not automatically distributed.

Please contact your local Siemens Healthineers office to order a current version or refer to our website <http://www.siemens-healthineers.com>.

Disclaimer

Siemens Healthcare GmbH provides this documentation "as is" without the assumption of any liability under any theory of law.

The content described herein requires superior understanding of our equipment and may only be performed by qualified personnel who are specially trained for such installation and/or service.

Copyright

"© Siemens Healthineers, 2014" refers to the copyright of a Siemens Healthineers entity such as:

Siemens Healthcare GmbH - Germany

Siemens Shenzhen Magnetic Resonance Ltd. - China

Siemens Shanghai Medical Equipment Ltd. - China

Siemens Healthcare Private Ltd. - India

Siemens Medical Solutions USA Inc. - USA

Siemens Healthcare Diagnostics Inc. - USA and/or

Siemens Healthcare Diagnostics Products GmbH - Germany

1	Prerequisites and Notes	7
1.1	Prerequisites	7
1.2	General Notes	8
1.2.1	General Safety Information	8
1.2.2	Manufacturer's Note	8
1.2.3	Maintenance Intervals	8
1.2.4	Remarks Regarding Maintenance	8
1.2.5	Explanation of Abbreviations in the Maintenance Instructions	9
1.3	Product-specific Information	10
1.3.1	Explanation of the Abbreviations in the Maintenance Certificate	10
1.3.2	Maximum Torque in Nm (Table)	10
1.3.3	Tools, Aids, Lubricants, Cleaning Agents and Paints	11
1.3.4	Applicable Components	11
1.3.5	DHHS Regulations	12
1.3.6	Corrective Measures / Adjustments	12
1.3.7	Cover Panels	12
1.4	Product-specific Safety Information	13
1.4.1	Patient Table	13
1.4.2	X-Ray Generator and System Control Cabinet	14
2	Part 1 AXIS/User Interfaces/RTCs/Displays	16
2.1	Special Requirements	17
2.1.1	Required Documents	17
2.1.2	Required Tools, Test Equipment and Aids	17
2.1.3	Required Materials	18
2.1.4	Required Work Time/Maintenance Interval, Biplane System	19
2.2	General Visual Check	21
2.2.1	Visual Check per IEC 62353	21
2.3	Image System (AXIS)	27
2.3.1	Mechanical Safety	27
2.3.2	Electrical Safety	27
2.3.3	Periodic Preventive Maintenance	28
2.3.4	Operating Values, Inspection	28
2.4	User interfaces	30
2.4.1	Product-specific Safety Information	30
2.4.2	Safety Inspection	30
2.4.3	Components	30
2.5	Wireless Footswitch	36
2.5.1	Product-specific Safety Information	36
2.5.2	Safety Inspection, Mechanical Safety	36
2.5.3	Preventive Maintenance, Cleaning	36
2.5.4	Electrical Safety	37
2.6	FD Cooling Unit	38
2.6.1	Product-specific Safety Information	38
2.6.2	Periodic Preventive Maintenance	39
2.7	Real-time Controller	41
2.7.1	Electrical Safety	41

2.8	Large Display / MDM	42
2.8.1	Special Requirements	42
2.8.2	Mechanical Safety	42
2.8.3	Inspection and maintenance for LD	44
2.8.4	Inspection and maintenance for MDM	46
2.8.5	Upkeep	46
2.8.6	Final Work Steps	47
2.9	Cockpit	50
2.9.1	Special Requirements	50
2.9.2	Mechanical Safety	50
2.9.3	Inspection and Maintenance	50
2.9.4	Upkeep	52
2.9.5	Final Work Steps	53
2.10	TFT Monitor	54
2.10.1	Special Requirements	54
2.10.2	Product-specific Information	54
2.10.3	Mechanical Safety	54
2.10.4	Electrical Safety	56
2.10.5	Inspection and Maintenance	56
2.10.6	Upkeep	56
2.11	Final Work Steps	57
2.11.1	Installing the Cover Panels	57
2.11.2	Electrical Safety, Ground Wire Check	57
3	Part 2 Generators/Support Arm System	61
3.1	Special Requirements	62
3.1.1	Required Documents	62
3.1.2	Required Tools, Test Equipment and Aids	62
3.1.3	Required Materials	63
3.1.4	Required Work Time/Maintenance Interval, Biplane System	64
3.2	X-ray Generator	65
3.2.1	Safety	65
3.2.2	Preventive Maintenance	65
3.2.3	Checking the Operating Parameters	69
3.3	Support Arm System (Radiation Shield, Injector Head...)	73
3.3.1	Safety Inspection	73
3.3.2	Cleaning	74
3.4	Final Work Steps	75
3.4.1	Installing the Cover Panels	75
3.4.2	Electrical Safety, Ground Wire Check	75
4	Part 3 Floor stand / Collimator / FD Laser Crosshairs	78
4.1	Special Requirements	79
4.1.1	Required Documents	79
4.1.2	Required Tools, Test Equipment and Aids	79
4.1.3	Required Materials	80
4.1.4	Work Time/Maintenance Interval	81
4.2	Floor Stand	82
4.2.1	Mechanical Safety	82

4.2.2	Electrical Safety, Safety Devices	85
4.2.3	Maintenance	90
4.2.4	Operating Values, Inspection	94
4.2.5	Function Inspection	95
4.2.6	Final Work Steps	96
4.3	Universal collimator (24 months)	97
4.3.1	Periodic Preventive Maintenance	97
4.4	Laser Crosshair FD (Laser Light) Option	99
4.4.1	Product-specific Safety Information	99
4.4.2	Mechanical Safety	99
4.4.3	Maintenance	99
4.4.4	Function Inspection	99
4.5	Final Work Steps	100
4.5.1	Installing the Cover Panels	100
4.5.2	Electrical Safety, Ground Wire Check	100
5	Part 4 Ceiling Stand (2nd Plane) / DCS / Collimator	102
5.1	Special Requirements	103
5.1.1	Required Documents	103
5.1.2	Required Tools, Test Equipment and Aids	103
5.1.3	Required Materials	104
5.1.4	Work Time/Maintenance Interval	105
5.2	Ceiling Stand (2nd Plane)	106
5.2.1	Safety - Ceiling Rails, Indirect Check of Ceiling Substructure	106
5.2.2	Ceiling Rail Maintenance	109
5.2.3	C-Arm Maintenance	117
5.2.4	Operating Values, Inspection	124
5.2.5	Final Work Steps	125
5.3	Universal collimator (24 months)	126
5.3.1	Periodic Preventive Maintenance	126
5.4	DCS	128
5.4.1	Periodic Preventive Maintenance	128
5.4.2	Mechanical Safety	131
5.4.3	Electrical Safety	136
5.4.4	Final Work Steps	138
5.5	Final Work Steps	139
5.5.1	Installing the Cover Panels	139
5.5.2	Electrical Safety, Ground Wire Check	139
6	Part 5 Patient Table / Heated Mattress / UPS / IQAP Tests / Final Work Steps	141
6.1	Special Requirements	142
6.1.1	Required Tools, Test Equipment and Aids	142
6.1.2	Required Documents	143
6.1.3	Required Materials	143
6.1.4	Work Time/Maintenance Interval	144
6.2	Patient Table	145
6.2.1	Affected Components	145

6.2.2	Mechanical Safety	145
6.2.3	Electrical Safety	150
6.2.4	Periodic Preventive Maintenance	155
6.2.5	Final Work Steps	157
6.3	Heated patient mattress	158
6.3.1	Visual inspection, mattress	158
6.3.2	Visual inspection, control module	158
6.3.3	Visual inspection, power supply	158
6.3.4	Operating and test components	159
6.3.5	Checking the Control Panel	160
6.3.6	Heated mattress check	169
6.3.7	Power supply test	172
6.3.8	STK inspection label (for Germany only)	173
6.4	Uninterruptible power supply	175
6.4.1	Mechanical Safety	175
6.4.2	Electrical Safety	175
6.4.3	Periodic Preventive Maintenance	175
6.4.4	Upkeep	176
6.4.5	Function Inspection	176
6.5	IQAP Tests	180
6.5.1	Image Quality	180
6.5.2	InSpace3D IQAP Maintenance Tests	181
6.6	Final Work Steps	183
6.6.1	Installing the Cover Panels	183
6.6.2	Resetting the Maintenance Counter	183
6.6.3	Run a config and version check	184
6.6.4	Electrical Safety, Ground Wire Check	185
7	Procedures	187
7.1	Protective ground wire test meter	187
7.1.1	Order directly	187
7.2	Cleaning the Large Display, Cockpit and TFT Monitor	188
7.2.1	Cleaning Information	188
8	Changes to Previous Version	191
9	List of Hazard IDs	192

1.1 Prerequisites



During maintenance on the product, the work steps in the certificate must be documented accordingly.

Maintenance is divided into chapters (maintenance packages of max. 6-7 hours).

With parts that must be replaced periodically (battery/steel cables...), the startup date or the last replacement date must be recorded to ensure the ability to track the dates. As a rule, the date can be found in the Operator Manual (Handover Certificate / old Maintenance Certificate).

1.2 General Notes

1.2.1 General Safety Information

When performing the work steps and checks, the general safety information contained in the ARTD (General Guidelines for Technical Service) must be observed.



WARNING

Dangerous X-radiation during check and adjustment work steps.

Risk of death or serious bodily injury.

- » **During the check and adjustment work steps that must be performed with radiation switched on, the mandatory radiation safety measures must be observed. These check and adjustment work steps are explicitly labeled on the following pages with the radiation warning symbol .**

1.2.2 Manufacturer's Note

Depending on the version, the illustrations and drawings can show slight changes versus the equipment actually shipped.

1.2.3 Maintenance Intervals

Maintenance must be performed in intervals of 12 months. If comprehensive system maintenance is not possible, partial maintenance can also be performed.

The maintenance time and the maintenance interval is listed in each chapter for a component or in the general chapters.

Work times for periodic replacement of parts such as batteries or filters are not contained in these maintenance instructions.

The work time can be viewed only as a reference value, because the time for cleaning, for example, can vary widely.

1.2.4 Remarks Regarding Maintenance

Damaged or worn parts may be replaced only with original parts.

The checklists "Inspection and Maintenance" must be filled out and signed by the customer service technician (CSE). Repair work and work steps that are not shown in the checklists must be listed separately.

When these Maintenance Instructions are performed completely, it is not necessary to perform work steps that have been repeated several times, e.g. ground wire measurement, check of the emergency stop.



Replace damaged parts in consultation with the customer.



The "Maquet" table is not a component of the SIEMENS system and thus is **not** maintained by SIEMENS.



The Trumpf "TRU System SF/SB Artis" table (Siemens Material Numbers: 10280784 and 10569809; Trumpf Material Numbers: 1519807 and 1501878) is a component of the SIEMENS system and is maintained by SIEMENS.

The Trumpf "TruSystem 7500 Hybrid Plus (SC)" and "TruSystem 7500 Hybrid Plus (FC)" tables (Trumpf Material Numbers: 1854088 and 1854087) is **not** a component of the SIEMENS system and therefore is **not** maintained by SIEMENS.

1.2.5 Explanation of Abbreviations in the Maintenance Instructions

Abbreviation	Explanation
DCS	Display Suspension System (D isplay C arriage (Suspension) S ystem)
DMG	Dead Man's Grip
FD	Flat Panel Detector (F lat panel D etector)
SID	Distance from the X-ray tube source to the detector (S ource I mage D istance)

1.3 Product-specific Information

1.3.1 Explanation of the Abbreviations in the Maintenance Certificate

Abbrev.	Explanation
SI	Safety Inspection
SIE	Electrical Safety
SIM	Mechanical Safety
PM	Preventive Maintenance
PMP	Periodic Preventive Maintenance
PMA	Maintenance, Preventive Adjustments
PMF	Preventive check of operating values and function
Q	System quality, image quality
QIQ	Image quality
QSQ	System quality
SW	Software maintenance
CSE	Customer Service Engineer (customer service technician)
Cust. No.	Customer-specific number
IVK	Installed Volume Components
WE	Maintenance Unit

1.3.2 Maximum Torque in Nm (Table)

Nominal thread diameter	Screw material			Steel per DIN 267				Brass, CuZn alloy
	Hardness rating	4.6	4.8	5.8	8.8	10.9	12.9	
M 3		0.5	0.67	0.83	1.3	1.9	2.2	0.62
M 3.5		0.76	1.0	1.3	2.0	2.8	3.4	0.95
M 4		1.1	1.5	1.9	3.0	4.2	5.1	1.4
M 5		2.2	3.0	3.7	6.0	8.4	10.1	2.8
M 6		3.8	5.1	6.4	10.2	14.4	17.3	4.8
M 8		9.5	12.6	15.8	25.3	35.6	42.7	11.9

M 10		18.7	24.8	31.1	49.8	70.0	84.0	23.3
M 12		32.9	43.8	54.8	87.6	123.3	147.9	41.1

When checking tightness, use the corresponding torque values for hardness rating 8.8.
A tolerance of $\pm 10\%$ is permitted for torque values.

1.3.3 Tools, Aids, Lubricants, Cleaning Agents and Paints



The required tools, aids, and materials for the chapters on component maintenance,

- Part 1 AXIS / User Interfaces / RTC / Displays
- Part 2 Generator / Support Arm System / DCS / USV
- Part 3 (4) Floor, Ceiling, Multi-purpose Stand / Robots / DCS / Laser Crosshair FD
- Part 4 (5) Patient Table / USV / Final Work Steps

are listed at the beginning of this chapter under the "Required Tools, Measuring Equipment and Aids" and "Required Materials" section

1.3.4 Applicable Components

- Image system
- RTC/s
- FD Cooling Unit/s
- Floor Stand (system-related)
- Ceiling Stand or 2nd Plane (depending on the system)
- Patient Table (system-related)
- Multi-purpose Stand (system-related)
- Robotic (KUKA) Stand (depending on the system)
- User interface
- Wireless Footswitch
- X-ray Generator
- Cooling Unit/s for X-ray Tubes
- Support Arm System or Radiation Shield and Injector Head
- Monitors/TFT Displays
- Monitors/TFT Display Support System (DCS)
- Large Display
- Uninterruptible Power Supply (UPS)
- FD Laser Crosshair
- Cockpit (9x) (Option)
- Collimator

- Heated Mattress

1.3.5 DHHS Regulations

This document does **not** replace the Artis zee/zeego Maintenance Instructions (Customer Document Type662....) "DHHS Maintenance Instructions/DHHS Measurement Certificate" in countries with DHHS regulations (e.g. USA).

1.3.6 Corrective Measures / Adjustments

Reference is made a number of times in the document to the Service SW for corrective measures or for adjustments.

For this, call up the adjustments, etc. in the Service SW program under "Options/Local Service".

1.3.7 Cover Panels

Depending on the work step, the corresponding cover panels must be first removed.

1.4 Product-specific Safety Information

Always observe the general safety information for medical products when performing work steps and checks.

1.4.1 Patient Table

Fig. 1: Lift safety stud, tilt safety brackets

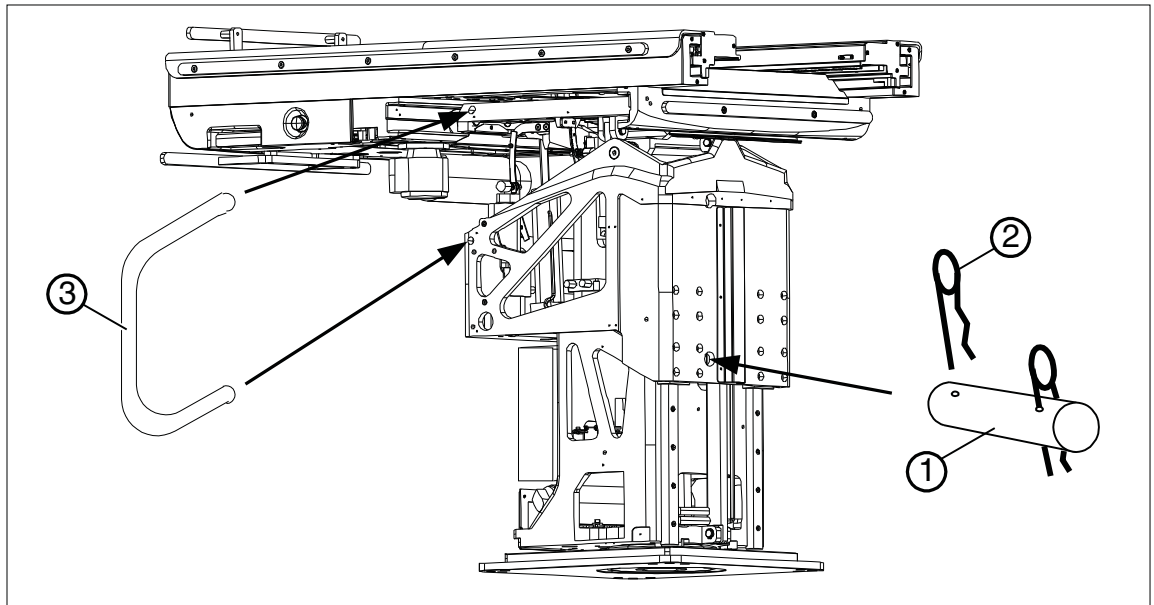

⚠ WARNING

Do not perform any service work inside the table unless precautions against unintentional lowering, and if applicable tilting, of the table have been taken.

If not observed, serious bodily injury can occur.

» Insert the lift safety stud and, if applicable, the tilt safety brackets.

■ Lift Safety Stud

Move the table all the way up, insert the lift safety stud (→ 1/Fig. 1 Page 13) from the outside into the table base and secure it with 2 cotter pins (→ 2/Fig. 1 Page 13).

■ Safety Brackets

For tilting tables, set the max. Trendelenburg position and install the two safety brackets (one bracket at both the right and left in the table) (→ 3/Fig. 1 Page 13). Install the safety brackets with 2 cotter pins each.

1.4.2 X-Ray Generator and System Control Cabinet

Always observe the general safety information for medical products when performing work steps and checks. (→ General Safety Notes / TD00-000.860.01)

WARNING

Even after switching off the system (Shutdown), power is still present at the control cabinet and generator.

If not observed, death or serious bodily injury can occur.

- » Observe the warning signs in the cabinets.
- » Switch off the power supply to the X-ray system with the on-site on/off switch.

hm_serv_LabelPowerPresent

CAUTION

The D102 reset board conducts voltage even when switched off.

- » Observe the warning labels.
- » Switch off the power supply to the X-ray system with the on/off switch installed on-site.

CAUTION

It is possible that the System Control Cabinet on the Reset Board D102 there are still external voltages present, even if the System is switched off by customer's Room Distributor Cabinet.

Observe the note on the Warning Label. Do not perform works on Board D102, if there are still external voltages present.

- » When working on the D102 check the external wires if there are still external voltages present and remove them, if necessary.

WARNING

In the POLYDOROS A100, these parts conduct line voltage even when switched off:

- » Observe the warning label in the cabinet.
- » After switching off the generator, there is still approx. 600 V DC voltage present at the D510 inverter! This is indicated by the V121 and V122 LEDs on the D510. The voltage dissipates in approx. 2 minutes to < 30 V; the LEDs go off at approx. 30 V.

 **WARNING**

Risk of accident!

- » As a rule, measurements must always be performed using an oscilloscope with the ground wire connected.
- » Disconnecting the ground wire without an isolation transformer is not allowed.
- » Working with an isolation transformer is permitted only if the voltage to be measured is not more than 25 V AC or 60 V DC.



Mandatory:

The ground wire test according to IEC 62353 absolutely must be performed at the end of the maintenance call before the system is turned back over the customer for patient operation.

This applies regardless of whether or not all planned maintenance points for this partial maintenance have been completed.

2.1 Special Requirements

2.1.1 Required Documents

- CB-DOC Artis zee, AXA4-000.803.02....

2.1.2 Required Tools, Test Equipment and Aids

- Standard toolkit 9702457
- Fluke 287 digital multimeter 9994831
- or
Multimeter, measurement range 1 to 20 Volt DC, accuracy at least 1%. n.a.
- Protective ground wire test meter This test meter, for example the general-purpose test meter, must meet the specifications of IEC 61557/EN 61557/VDE 0413/IEC 62353.
® SIII or SECUTEST PROFITEST® 0100S-II (→ Order directly / Page 187)
- or
Safety Analyser Rigel 62353 230V 10848526
Safety Analyser Rigel 62353 130V 10848527
- or
Rigel 288 Order directly from Rigel
- or
Fluke ESA 612 / ESA 615 Order directly from Fluke
- ESD equipment 9702606
- Lint-free cleaning cloths n.a.
- Brush to remove dust n.a.
- Antistatic vacuum cleaner with nozzle (observe country-specific regulations) n.a.
- Luminous density test meter 7752848
e.g. SMfit ACT (luminous density meter)

Tools for the Large Display:

- | | |
|--|---------|
| ■ Torque wrench, 8 to 40 Nm
(with 17 mm open-end wrench attachment) | 9900846 |
| ■ Torque wrench, 20 to 100 Nm
(with open-end wrench attachments SW 8, 10, 11, 12, 13, 14,
15, 16, 17, 18 and 19) | 8086159 |
| ■ 3/8" attachment for the torque wrench | 7058928 |
| ■ 6mm hex attachment set
(including the 3/8" to 1/4" snap-on adapter) | 8159980 |

All tools, test equipment and aids listed with a part number can be ordered from the Service Parts Catalogue (SPC).

2.1.3 Required Materials

- | | |
|---|-----------------------------|
| ■ Lithium batteries for the image system (3 for biplane or 2 for monoplane system, 1 for Large Display MDM, 1 for Cockpit), Type CR2032 (replace every 3 years) | 3082146, or procure locally |
| ■ Batteries for the wireless footswitch
(replace every 2 years) | 4787789 |
| ■ GLYCOMIX 40 coolant for the Klüver FD cooling unit | 4007873 |
| ■ GLYCOMIX 40 coolant for the SMC FD cooling unit | 10143774 |
| ■ Cleaning agent for plastic, glass and enameled parts, e.g., Hakapur cleaning concentrate (500 g) | 9660648 |
| ■ Alcohol | n.a. |

Paints to touch up chips/scratches in the paint finish

- | | |
|---|---------|
| ■ White (spray can) | 8427734 |
| ■ White textured (paint stick) | 3444403 |
| ■ Medical Blue (spray can) ¹ | 5507046 |
| ■ Medical Blue (paint stick) ² | 5507087 |

1. Color: light blue

2. Color: light blue

Permissible Cleaning Agents for the Large Display, Cockpit and TFT Monitors:
(see also System Operator Manual)

Active ingredient class	Tested Cleaning Agents and Disinfectants	Examples
Alcohol	Ethyl alcohol, 96%	Hospiset cloth Microcide liquid
Aldehyde	Melsitt Cidex	Aldasan 2000 Kohsolin Gigasept FF
Chlorine derivatives	Terralin	Quartamon Med
Disinfectants	Taski DS5001 (Diverseylever Labs) Morning Mist Surfanios Fraicheur Citron (Anios Labs)	
Guanidine derivatives	Lysoformin	
Quaternary compounds	Incidur spray, full strength	
Commercially available dish-washing liquid	Tempo	Fairy Ultra, Pril, Palmolive
Benzine	Petroleum ether	
Prydine derivatives	Activ spray, full strength	
Water	Tap water Distilled water	

2.1.4 Required Work Time/Maintenance Interval, Biplane System

Component	Required Work Time/Maintenance Interval
General Visual Check	0.25 hr. / 12 months
Image System	1.5 hours / 12 months
User Interface	1 hour / 12 months
Wireless Footswitch (Option)	0.5 hr. / 24 months
FD Cooling Unit, Plane A	0.5 hr. / 12 months
FD Cooling Unit, Plane B	0.5 hr. / 12 months
Real-time Controller, Plane A	0.5 hr. / 12 months
Real-time Controller, Plane B	0.5 hr. / 12 months
Large Display	0.5 hr. / 12 months

Component	Required Work Time/Maintenance Interval
Cockpit (9x)	0.25 hr. / 12 months per Cockpit (9x)
TFT Monitor	0.5 hr. / 12 months (10 minutes per monitor)
Total Work Time, Partial Maintenance 1:	approx. 6.50 hrs./12 months

2.2 General Visual Check

2.2.1 Visual Check per IEC 62353

SI Checking the Cover Panels

1. All required cover panels are present.
 - a) Check the cover panels for visible damage, sharp edges or cracks.

SI Required operator documents present

1. Are the required operator documents complete, present, legible?
 - a) In new systems, there is a list with the documents that were shipped in the System Binder.
 - b) Based on this list, completeness can be checked easily.
 - c) **The following always applies:** All Operator Manuals, supplements and safety notes required for **use** of the system must be present.

SI Checking the cable corrugated hoses

1. The cables (corrugated hoses) may not have any cracks in the insulation.
2. Check the corresponding strain reliefs or cable shielding connections.
 - a) The check refers only to laid cables that are visible and the way in which they are laid!

SI Checking the cable corrugated hoses (of mobile components)

1. Check the way in which cables are laid (corrugated hoses) to mobile components.
 - a) The cables should not pose a risk of tripping and should not be laid over any sharp edges.
 - b) The check refers only to laid cables that are visible and the way in which they are laid!

SI Checking the Radiation Safety Panels

1. To the extent configured, visually check the following radiation safety panels for cracks or other damage:
 - a) Radiation safety cover panels
 - b) Lead rubber flaps
 - c) Ceiling-mounted radiation shield
 - d) Additional radiation shields that can be installed
 - e) Movable radiation shield

SI Checking warning labels

1. All warning labels that indicate a risk (to operator, patient or unit) that can occur during operation of the system must be present and recognizable.
 - a) e.g.: Crushing of fingers, crushing of feet, laser, maximum load, collision warnings.

Tab. 1 Table of Warning Labels

Artis zee / zeego	
Where?	Illustration ¹
In the area of the system on / off switch (on the ACE)	Generator ON <i>Fig. 2:</i> <div style="border: 1px solid black; padding: 10px; margin: 10px 0;"> <p>WARNING: THIS X-RAY UNIT MAY BE DANGEROUS TO PATIENT AND OPERATOR UNLESS SAFE EXPOSURE FACTORS AND OPERATING INSTRUCTIONS ARE OBSERVED.</p> </div> Generator EIN Generator ON

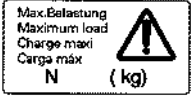







Table frame

Artis CPR

Fig. 3:CPR Artis rechts
CPR Artis, rightCPR Artis links
CPR Artis, left*Fig. 4: Artis zee/zeego CPR*

Or /Oder



Artis zee / zeego	
Where?	Illustration ¹
<p>Tabletop</p> <p>NOTE:</p> <p>The label is on the table support with Artis zee Multi-purpose systems.</p>	<p>Maximum patient load</p> <p>Fig. 5:</p> <div style="display: flex; justify-content: space-around; align-items: center;"> <div style="text-align: center;">  <p><i>Max. Belastung</i> <i>Max. load</i></p> </div> <div style="text-align: center;">  <p><i>Maximale Patientenlast</i> <i>Maximum patient load</i></p> </div> </div>
<p>In the vicinity of table rotation / tabletop longitudinal movement</p>	<p>Risk of crushed fingers, white</p> <p>Fig. 6:</p> <div style="display: flex; justify-content: space-around; align-items: center;">   </div> <p><i>Fingerquetschen gelb</i> <i>Finger crushing risk, yellow</i></p> <p><i>Fingerquetschen weiss</i> <i>Finger crushing risk, white</i></p>
<p>C-Arm</p>	<p>Risk of crushed fingers, yellow (26 mm)</p> <p>Fig. 7:</p> <div style="display: flex; justify-content: space-around; align-items: center;">   </div> <p><i>Fingerquetschen gelb</i> <i>Finger crushing risk, yellow</i></p> <p><i>Fingerquetschen weiss</i> <i>Finger crushing risk, white</i></p>
<p>C-Arm mount</p>	<p>Risk of crushed fingers, yellow (26 mm)</p> <p>Fig. 8:</p> <div style="display: flex; justify-content: space-around; align-items: center;">   </div> <p><i>Fingerquetschen gelb</i> <i>Finger crushing risk, yellow</i></p> <p><i>Fingerquetschen weiss</i> <i>Finger crushing risk, white</i></p>

1. For the "illustrations", see the pictograms and part numbers in the document AX00-000.820.04....(→ Warning Labels / AX00-000.820.04)

Support arm systems for upper body radiation shield, surgery light	
Where?	Illustration¹
<p>On the support arm system.</p> <p>NOTE:</p> <p>Warning label in the national language or as a symbol/pictogram</p>	<p>Collision, check</p> <p><i>Fig. 9:</i></p> <div data-bbox="507 477 1217 1003" style="border: 1px solid black; padding: 10px;"> <div style="background-color: orange; color: white; text-align: center; padding: 5px;">⚠ WARNING</div> <div style="border: 1px solid black; padding: 5px; margin-top: 5px;"> <p>COLLISION WITH OTHER EQUIPMENT CAN CAUSE STRUCTURAL FAILURE OF SUSPENSION ARM, RESULTING IN OPERATOR OR PATIENT INJURY, IF COLLISION OCCURS, IMMEDIATELY HAVE ARM INSPECTED BY A QUALIFIED SERVICE TECHNICIAN.</p> </div> <p style="margin-top: 10px;">Kollision, Überprüfung Collision, Inspected</p> </div> <p><i>Fig. 10: Collision warning label</i></p> <div data-bbox="507 1205 1109 1485" style="border: 1px solid black; padding: 5px; text-align: center;">  </div> <p>Warning Label as Pictogram (with the MAVIG, new shipments beginning approx. middle of 2013)</p>

1. For the "illustrations", see the pictograms and part numbers in the document AX00-000.820.04... (→ Warning Labels / AX00-000.820.04)

Artis zeego (Robot Stand)	
Where?	Illustration¹

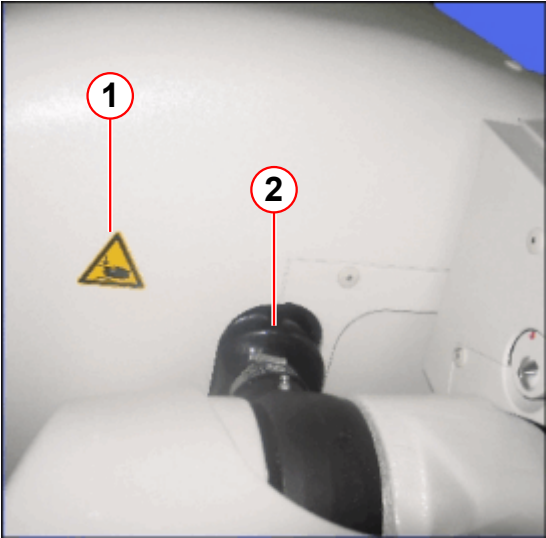
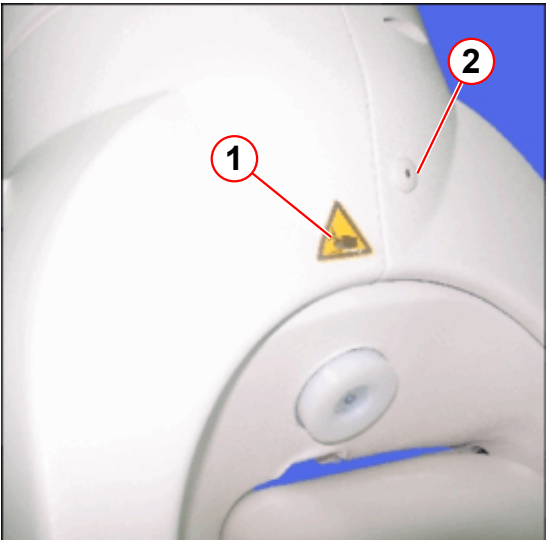
<p>Artis zeego (Robot Stand)</p> <p>on the cover of the Safe RDC.</p> <p>NOTE: Safe RDC is configured only if the KUKA control cabinet has the Part Number 102 80 988.</p>	<p>Rescue Label, Part No. 108 42 959</p> <p><i>Fig. 11: Patient rescue label</i></p> 
<p>On the stand cover between Axis 1 and Axis 2</p>	<p>Risk of crushed fingers, yellow (40 mm)</p> <p><i>Fig. 12: Axis 2</i></p>  <p>(1) Label, 40 mm (2) Bellows</p>
<p>On Axis 5 on both sides</p>	<p>Risk of crushed fingers, yellow (26 mm)</p> <p><i>Fig. 13: Label on the manual axis</i></p>  <p>(1) Label, 26 mm (2) Paneling screw</p>

-
1. For the "illustrations", see the pictograms and part numbers in the document AX00-000.820.04....(→ Warning Labels / AX00-000.820.04)

2.3 Image System (AXIS)

2.3.1 Mechanical Safety

2.3.1.1 Visual Check

SI Components

Check the following components for mechanical damage and clean them if necessary:

1. Image system container with cover panels
2. Operating elements (mouse, keyboard, ACE module)

2.3.1.2 Checking the Internal Unit

PM Image System

Remove the cover panels on the image system container (front, top and side) and perform the following actions:

1. Remove dust from inside the container (chassis, power supply, modules, PCs).
2. Clean the filter (use a vacuum cleaner). The filter is located on the inside of the front cover.
3. Check the function of the fans on the back of the container.
4. Pull out the IVS, IAS PCs towards the front, remove the left cover and check the function of the fans.
5. AXIS: Container fan, ACE fan and all PC fans (side fans, front fan, reverse fan. Also see (→ AXIS Image System SW VC13 / AXA4-000.841.09)(→ AXIS Image System SW VC14 / AXA4-000.841.19)(→ AXIS Image System SW VC2x / AXA4-000.841.24)(→ AXIS Image System, VD1x SW / AXA4-000.841.27)).

PM ACE Module

1. Check the function of the fans on the back of the container.

2.3.2 Electrical Safety

2.3.2.1 Visual Check

SI Components

Check the following components for mechanical damage:

1. Connectors
2. Cables
3. Strain reliefs

4. When moving the IVS and IAS carriages in and out, the cables must move correctly on the extractor rails and may not be kinked or pinched.

2.3.3 Periodic Preventive Maintenance

2.3.3.1 Replacing the Batteries

PMP Replacing the IVS/IAS (A/B) Batteries

1. The batteries in the IVS, IAS PC must be replaced periodically, every 3 years; replacement is described here.

For the VC14 SW: (→ PC Battery / AXA4-000.841.19) or (→ PC Battery / AXA4-000.841.19)

For the VC2x SW: (→ PC Battery / AXA4-000.841.24) or (→ PC Battery / AXA4-000.841.24)

For the VD1x SW: (→ PC Battery / AXA4-000.841.27) or (→ PC Battery / AXA4-000.841.27)

2.3.4 Operating Values, Inspection

2.3.4.1 Checking the System Time

PMF Checking and Setting the System Time

1. Start the service software under **Options > Service > Local Service**.
2. Select the **Configuration** menu item.
3. Select **Site Info** in the Configuration menu and continue with ">".
 - » The currently set system time will be displayed and can be changed directly, if necessary!

Fig. 14: System time with system SW VCxx

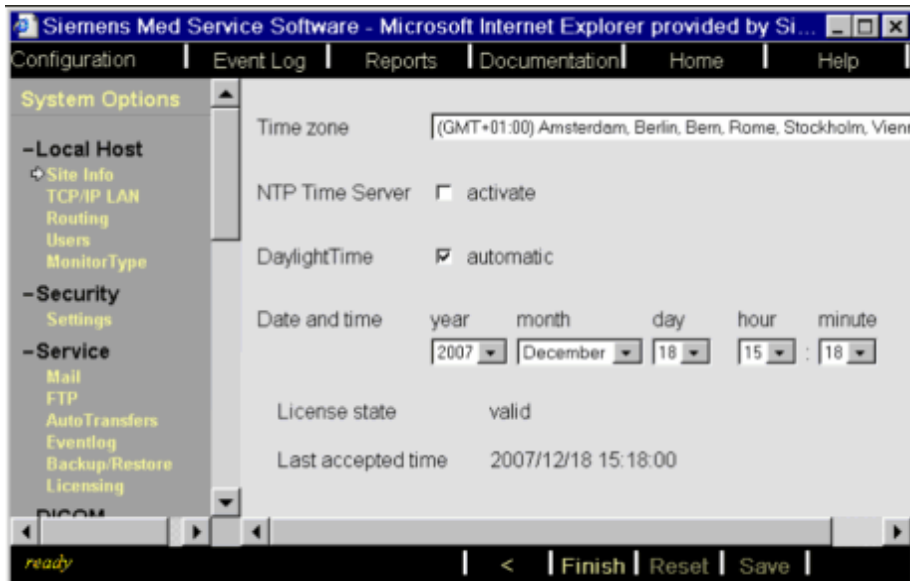

2.3.4.2 Function Check

PMF Imaging system

Check the function of the following image system components:

1. Check the function of the mouse, keyboard and ACE module.

2.3.4.3 Checks in the Service Mode

PMP Reading out the Error Log

1. Open the Local Service menu and start the Event Log.
2. Select **"Service"** under Facility and start the event log reader with **Go**.
3. Check whether there are service-relevant errors with the following "Source" names:
 - AX_IVS
 - AX_IAS
 - AX_ISC
 - AX_DEV

2.4 User interfaces

The user interface components are largely maintenance-free. Maintenance work is limited to cleaning and function tests.

2.4.1 Product-specific Safety Information

- Perform the maintenance work steps on the user interface components only when the system is switched off.
- No components need to be opened for maintenance.

2.4.2 Safety Inspection

Always observe the general safety information for medical products when performing work steps and checks.

2.4.2.1 Mechanical Safety

SIM Housing Parts

1. Check all component housings for damage.
 - The housings may not have any cracks or similar problems.
2. Replace defective components.

SIM Mounting parts

1. Check the ECC and control modules for secure mounting.
2. Remove the ECC from the accessory rail and check the mounting parts.
3. Remove the control modules from the accessory rail and check the mounting parts.
4. Check the data display mount on the DCS and, if applicable, in the control room (option).

2.4.3 Components

The user interface includes the following components:

- ECC / ECC J
- DDIS
- Control modules

Artis zee Biplane/Floor/Ceiling/MP	Artis zeego Multi-axis (Robot)
SCM	RCM LCM

Artis zee Biplane/Floor/Ceiling/MP	Artis zeego Multi-axis (Robot)
TCM	TCM
CCM	CCM

- Footswitch
- Wireless Footswitch
- Handswitches
- ULI Board

2.4.3.1 ECC

PMP Cleaning

1. Remove contrast medium residue and other dirt.



Do not clean the touchscreen with abrasive cleaning agents.

PMP Visual Check

1. Check all ECCs and ECC supply cables for damage. If necessary, replace the damaged parts.

PMF Function Test

1. Select all tab cards and select the various icons.
 - » The selected function must be performed.

Perform the joystick test:

1. Start the service software (→ Starting the Local Service (Service UI) / AXA4-000.843.05).

2. Select **Test Tools** and select **Hardware Tests**.

Fig. 15: ECC Joystick Test Tools

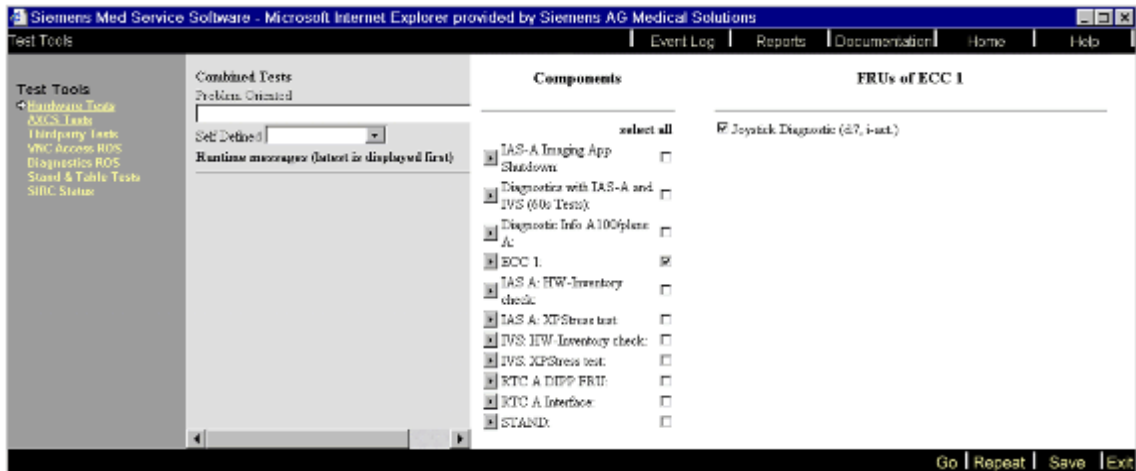

3. Select the desired ECC and click on **Go** in the command bar.
4. Perform the interactive test on the selected ECC.
5. Move the joystick in all directions and observe the display.
 - » The value range goes from 0- ± 127.
6. Press all joystick buttons, one after the other.
 - » The display must change from "inactive" to "active".

Fig. 16: ECC joystick test

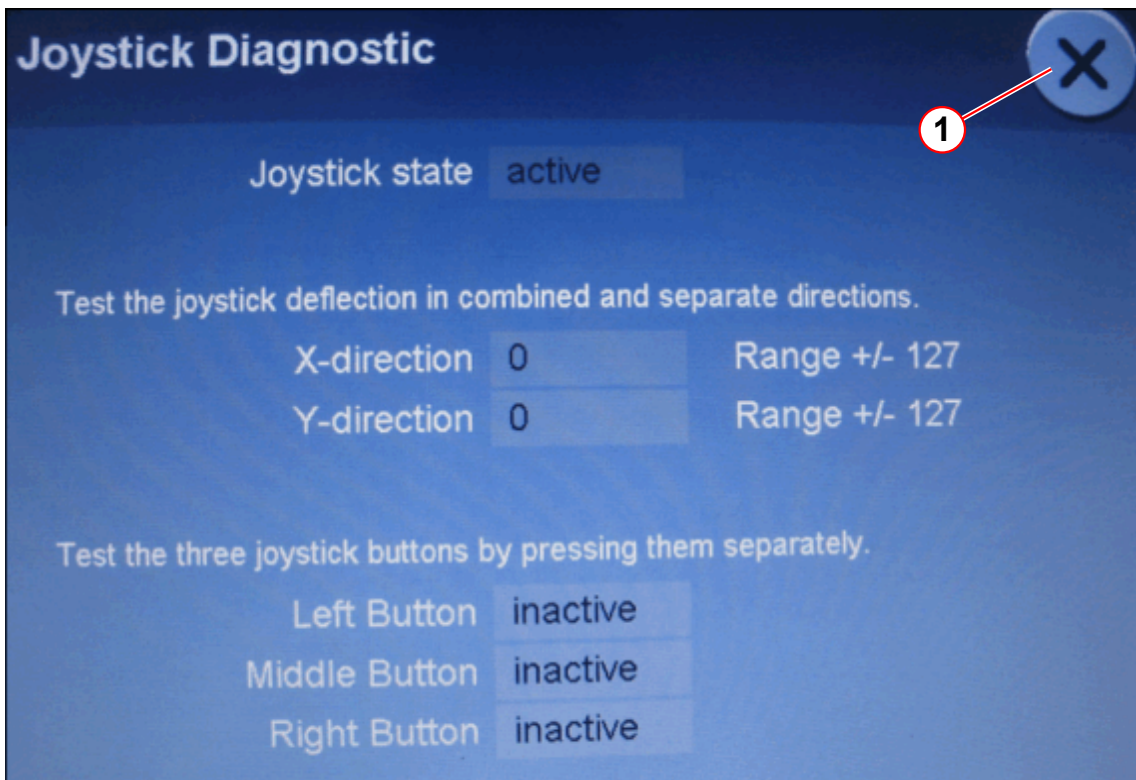

7. Once all functions have been tested, end the test at the ECC (→ 1/ Fig. 16 Page 32).

8. Perform tests on all ECCs present.

2.4.3.2 DDIS

PMP Cleaning

1. Remove all dirt.



Do not clean the display with abrasive cleaning agents.

PMP Visual Check

1. Check all displays and supply cables for damage. If necessary, replace the damaged parts.

PMF Function Test

1. Check all displays for whether they display completely.
2. Select various unit and table positions and check the displays.

2.4.3.3 Control Modules

PMP Cleaning

1. Shut down the system and switch it off.
2. Remove the cover panel on the particular control module.
3. Clean the control module and cover panel
4. Reinsert the cover panel.

PMP Visual Check

1. Check the control modules for damage. If needed, replace the damaged control module.

PMF Function test

1. Switch on the system and let it boot up.
2. During boot up, all LEDs on the control modules light up briefly.
 - » Each LED must light up briefly.
3. Press all buttons.
 - » The selected function must be triggered.
4. Check the joystick functions.
 - » Every selected movement must be performed.

SI Emergency Stop Switches

1. System is in normal mode.
2. Press the emergency stop switch on a control module and then initiate one of the unit movements.
 - » The emergency stop switch remains in the pressed position.
The message "Emergency stop pressed" appears on the data display.
Unit movements may no longer be possible.
3. Pull out the emergency stop switch.
 - » The emergency stop switch remains in the normal position.
Unit movements are possible again.
The message regarding the emergency stop switch no longer appears on the data display.
4. Repeat the test with all other control modules.

2.4.3.4 Footswitch**PMP** Visual Check

1. Check the footswitches. There may not be any loose parts.
2. Check the rockers and switches for ease of movement.

PMP Cleaning

1. Remove all dirt (especially contrast medium residue). Make sure that the dirt under the footswitch pedals is also completely removed.

PMF Function test

1. System is in normal mode.
2. Select all footswitch functions, one after the other.
 - » The corresponding function must be triggered.

2.4.3.5 Handswitches**PMP** Visual Check

1. Check the handswitches for mechanical damage.

PMP Cleaning

1. Clean the handswitches.

PMF Function test

1. System is in normal mode.
2. Check all functions of the handswitch.

2.4.3.6 ULI Board

The ULI board is maintenance-free.

2.5 Wireless Footswitch

2.5.1 Product-specific Safety Information

Perform the work steps for maintenance of the wireless footswitch only when the system is switched off. Exception: Function Check

2.5.2 Safety Inspection, Mechanical Safety

2.5.2.1 Visual Inspection

SI Components

Check the following components for mechanical damage:

1. Wireless Footswitch: loose parts and components
2. Check the switches for good function and easy action.
3. Charging station

2.5.3 Preventive Maintenance, Cleaning

PMP Cleaning

1. Remove all dirt (especially contrast medium residue). Make sure that the dirt under the pedals of the footswitch is completely removed.

2.5.3.1 Periodic Preventive Maintenance

PMP Replacing the Batteries

1. The batteries in the footswitch must be replaced every 24 months.

2.5.3.2 Operating Value Inspection

PMF Function Check

1. Switch on the system and establish the normal mode.
2. Check all functions (pedals) of the footswitch, one after the other. The corresponding function must be triggered.

2.5.4 Electrical Safety

2.5.4.1 Visual Inspection

SI Components

Check the following components for mechanical damage:

1. Charger connector
2. Charger cable

2.6 FD Cooling Unit

2.6.1 Product-specific Safety Information



CAUTION

The cooling fluid consists of a glycol-water mixture. This is hazardous to health if swallowed. Repeated skin contact can cause skin irritation.

- » If swallowed, contact a physician immediately.
- » Wear gloves, and if applicable, safety glasses.
- » For further information, refer to the GLYCOSHELL/GLYCOMIX LONGLIFE Materials Safety Data Sheet (CB-DOC -> Safety -> FD-Detector) as shown to the links: Klüber: (→ Coolant GLYCOSHELL Safety Data Sheet (for EC) / AXA4-110.860.01) (→ Coolant GLYCOSHELL Safety Data Sheet (for USA, Canada) / AXA4-110.860.02) SMC: (→ Coolant GLYCOMIX40 Safety Data Sheet / AXA4-110.860.03)(→ Coolant GLYCOMIX40, GLYCOMIX40-24DL Safety Data Sheet / AXA4-110.860.04)

hm_serv_HandleCoolingMediumWithCare



CAUTION

When connecting the cooling hoses, some coolant can leak out.

If this liquid gets into the RTC, it can cause damage.

- » Switch off the cooling unit, cover the RTC and only then connect the cooling hoses.

**WARNING**

Leakage of FD Cooler cooling fluid into the system cabinet leads to electrical disturbances and damage to electronic components, e.g. short circuit in the power supply (Main Distributor), RTC, etc..

System failure and injury to the patient due to an interruption in the interventional procedure.

- » Observe carefully the instructions regarding FD cooling unit, cooling hoses and connectors, especially:
- » Careful handling of the connectors (release/unlock with the button before disconnecting)
- » Proper placement of the zipper hoses (pushed up above the connectors) - not applicable for cooling units with a dedicated drip-pan.
- » Correct laying of the hoses (bending radius, pinching)

hm_serv_FdCoolHoseConnectorCare

2.6.2 Periodic Preventive Maintenance

PM Inspecting the Hose Couplings

1. Check that the hose couplings are intact and tight (visual inspection).

PM Checking the Cooling Unit

1. Check the cooling unit for any leaks (visual check).
 - a) To the extent possible, check the catch basin under the cooling unit for any freshly leaked or dried coolant (visual check).
 - b) Check the components that are located in the cabinet under the cooling unit, e.g. the RTC, power distributor (Main Distributor (MD)), etc., for spotting from freshly leaked or dried coolant (visual check).

PM Checking the Detector Coolant

Fig. 17: SMC FD cooling unit

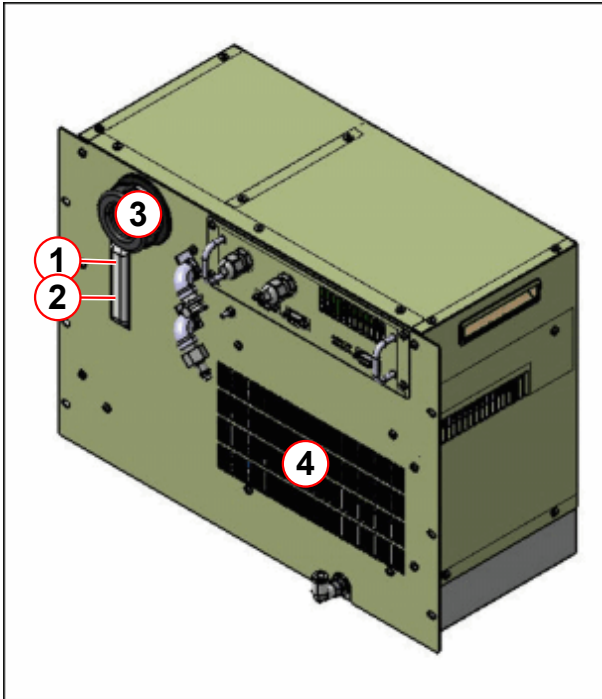

- (1) Maximum fill indicator
- (2) Minimum fill indicator
- (3) Coolant fill pipe
- (4) Overflow

Fig. 18: Klüber FD cooling unit

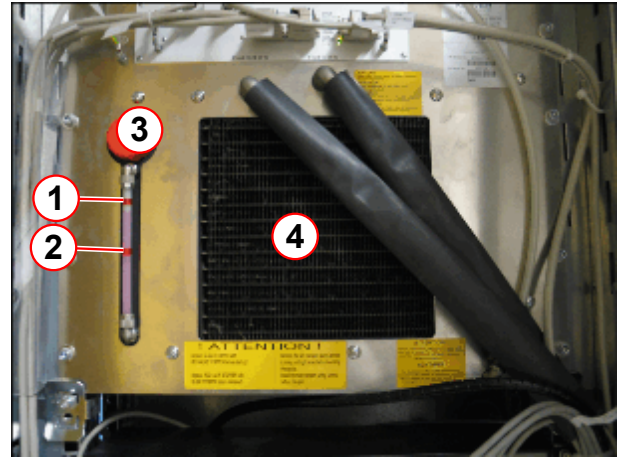

- (1) Maximum fill indicator
- (2) Minimum fill indicator
- (3) Coolant fill pipe
- (4) Overflow

1. The coolant level display must be between the min. and max. mark (→ 1-2/Fig. 17 Page 40) (→ 1-2/Fig. 18 Page 40).
2. The coolant level may not drop below the lower mark in one year.



If an unexpected high loss of coolant is detected, it is possibly a malfunction in the cooling unit or in the cooling hoses.

3. Add coolant at the refill opening (→ 3/Fig. 17 Page 40) until the top mark (→ 3/Fig. 18 Page 40) is reached.

PMP Cleaning the Cooling Fins

1. Remove any dust from the cooling fins of the cooling unit (→ 4/Fig. 17 Page 40) (→ 4/Fig. 18 Page 40) with a brush or a vacuum cleaner.

2.7 Real-time Controller

2.7.1 Electrical Safety

SI Check of the Bypass mode



1. Click on **Configuration** in the "Service Software" window.
2. Click on **System Config** under "Artis System".
3. **Trigger fluoroscopy.**
 - » The bypass **fluoroscopy image** must appear on the **Live TFT Monitor** in the examination room in less than two seconds. If not, check whether the coaxial cable is connected on the FDR board or to the TFT monitor.
4. Click on **Exit**.
5. Click on **Finish**.
6. Click on **Home**.

SIE Connectors and Cables

1. Check the connectors and cables for damage and for good contact.

2.7.1.1 Periodic Preventive Maintenance

See the RTC HW Overviews for the VC13 SW (→ RTC HW Overview / AXA4-000.841.08), VC14 SW (→ RTC HW Overview / AXA4-000.841.10) VC21 SW (→ RTC HW Overview / AXA4-000.841.22) and the VD11 SW (→ RTC Overview / AXA4-000.841.28).

PMP Cleaning

1. Check the two fans below in the RTC and the AT power supply fan in the top part of the RTC for quiet operation and for good air circulation.
2. Remove any collected dust at the fan grids and on the boards.

2.8 Large Display / MDM

2.8.1 Special Requirements

2.8.1.1 Required Documents

- If there are brightness/contrast problems, see the document system CB-DOC > Service > Monitors > Large Display > Adjustment.

2.8.1.2 Product-specific Safety Information



The safety information in the customer's Operator Manual must be observed for all activities on the system.

2.8.2 Mechanical Safety

2.8.2.1 Visual Inspection of Exterior

PMP Damage

1. Check the display for damage, e.g. for damage to the housing.

2.8.2.2 Mount

SIM Display Mount

Visual inspection:

The Vesa mounting plates (4x) must be flat on the display, they may not be bent up; visually check, see (→ 4/Fig. 19 Page 43).

Fig. 19: Visual check of the adapter

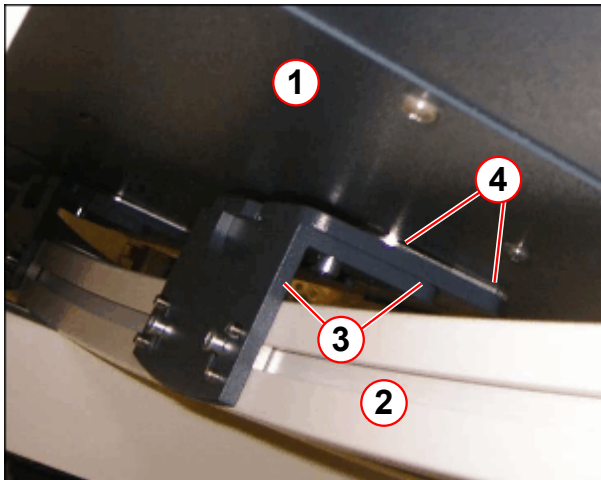

- (1) Display
- (2) DCS
- (3) Vesa adapter
- (4) Placement of the Vesa adapter on the display

Check of screw tightness:



Using a torque wrench, check that the 4 screws securing the display (display \Leftrightarrow DCS) are tight to 15 Nm.

The two "top" mounting screws are checked with the 6 mm Allen wrench, see (\rightarrow 1, 3, 4, 5/ Fig. 20 Page 43).

The two "bottom" mounting screws are checked with the 13 mm open-end wrench, see (\rightarrow 1, 2/ Fig. 20 Page 43).

Fig. 20: Torque wrench with 6 mm Allen wrench and 13 mm open-end wrench

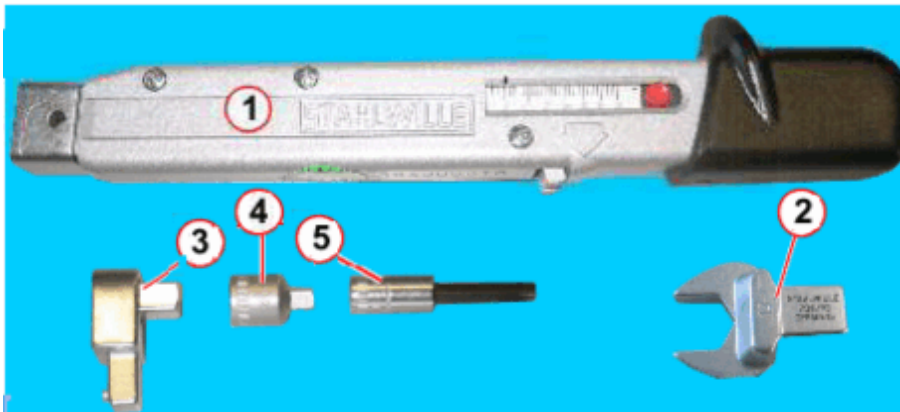

- (1) Torque wrench 8 to 40 Nm (99 00 846)
- (2) 13 mm open-end wrench attachment (component of 80 86 159)
- (3) 3/8" adapter attachment for torque wrench (70 58 928)
- (4) 3/8" to 1/4" adapter (component of 81 59 980)
- (5) 6 mm hex attachment 1/4" (component of 97 02 457)

2.8.3 Inspection and maintenance for LD

QSQ Check / Cleaning of the Fans

1. Check the 3 fans on the back of the display for any dust that has collected.

NOTICE

If the fans are clogged with dust, it is possible that the required cooling will no longer be ensured.

As a result, image quality disturbances/image failure can occur or the display can fail completely.

» The fans absolutely must be cleaned if they are dirty!

Fig. 21: LD fan

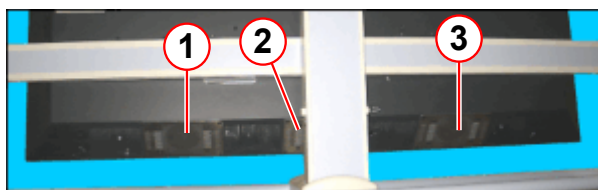

- (1) Left fan
- (2) Center fan
- (3) Right fan

2. If dust has collected in the fan area, clean the fans.
 - a) Switch off the display (switch off the power switch on the back, top left).
 - b) Remove the fan/s by removing the 4 mounting screws.
 - c) Clean the fans.

Note: If the fan is cleaned using a vacuum / or with blown air, stop the fan blade to prevent damaging the bearing.

Fig. 22: LD right and left fan replacement

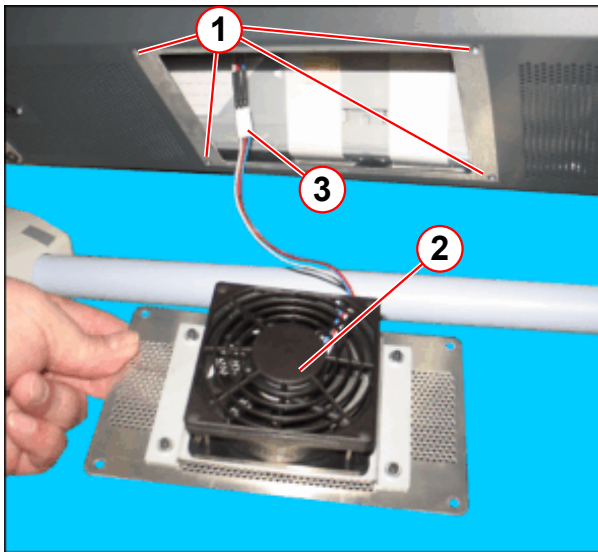

- (1) Screws
- (2) Fan
- (3) Connector

3. Reinstall the fan/s and switch the display on again.

QSQ Brightness and Contrast

1. **Service UI > Configuration > Artis Components > SMFit (LargeDisplay)> right arrow (bottom right) > Service > Test Pattern > General Purpose**
2. Select the "Square 100%/20%" test image.
3. The SMFit test meter must measure the following values in the white area, according to the display type:

Display Type	10293009 (56")	10656046 (60")	10656054 (55")
Max. brightness	300 cd/m ² +/- 30 cd/m ²	350 cd/m ² +/- 35 cd/m ²	400 cd/m ² +/- 40cd/m ²

- » If the tolerance value is exceeded, perform an adjustment (Configuration/ Adjustment Instructions...).



The values for the 60" LD were changed in mid-2015 from 300 cd/m to 350 cd/m

4. Select the square "0%/20%" test image.

5. The SMFit test meter must measure the following values in the black area, according to the display type:

Display Type	10293009 (56")	10656046 (60")	10656054 (55")
Black value	0.45 cd/m +/- 0.15 cd/m	0.45 cd/m +/- 0.15 cd/m	0.40 cd/m +/- 0.15 cd/m

- » If the tolerance value is exceeded, perform an adjustment (Configuration/Adjustment Instructions...).



If the Gamma was changed per the Configuration/Adjustment ... document because of image quality reasons, the black value can have other tolerance values.

2.8.4 Inspection and maintenance for MDM

PMP Fan check / cleaning for MDM

1. Remove the MDM container front cover, see: (→ Opening the MDM Container and Removing the MDM / TD00-LD1.841.03)
2. Clean the fan in the front cover and check its function.
3. Remove dust from inside the container (chassis, power supply, modules, PCs).
4. Clean the fan in the MDM and check its function. For details see: (→ Replacing the MDM fan / TD00-LD1.841.03).

PMP Replacing the MDM BIOS battery (36-month interval)

1. Depending on the MDM hardware version, the BIOS battery has to be replaced every 3 years. The replacement for the MDM material numbers affected is described here: (→ Replacing the MDM BIOS Battery / TD00-LD1.841.03)

2.8.5 Upkeep

PMP Cleaning the TFT Display



The display housing is made of plastic. To remove any residue, do not use any sharp objects or fluids that can melt plastic such as acetone, ether, solvent, trichloro-hydrocarbons, etc., see the approved cleaning agents (→ Tab. 7 Page 188).



The information regarding cleaning agents absolutely must be observed.
See: (→ Cleaning the Large Display, Cockpit and TFT Monitor / Page 188)
If the listed agents are not used, the surface will be irretrievably damaged.
Cleaning agents may not remain on the surface for an extended period.
If this is not observed, the warranty is invalidated.

Equipment Care, Cleaning and Disinfection:

1. The front of the display is very sensitive to mechanical damage; absolutely avoid scratches, shocks, etc.
2. Promptly remove any drops of liquid that fall on it; extended contact with liquids may cause, for example, discoloration or calcium outlines on the surface.
3. If there is dirt on the front of the display, clean it with a microfiber cloth and if necessary with a cleaning agent. Clean housing components only with the recommended cleaning agents.
4. If a cleaning agent is sprayed directly on the display surface, make sure that any droplets that run down are wiped off with a microfiber cloth before they reach the edge of the panel.
5. For permissible cleaning agents, see the system Operator Manual

2.8.6 Final Work Steps

2.8.6.1 Installing the Cover Panels on the Large Display

1. Reinstall all cover panels that were removed.

2.8.6.2 Installing the Large Display Protective Screen (Option)

PMP LD Protective Screen, Checking and Cleaning

1. Check the Plexiglas protective screen with mount for mechanical damage, scratches, and for any changes in the transparency.
2. Perform a check to ensure that the protective screen is held securely on the Large Display (LD).

3. Clean the protective screen. For this, use luke-warm soapy water and a soft, lint-free cloth.

Carefully remove any dirt or contrast medium. When doing this, make sure you do not scratch the Plexiglas.

ATTENTION:

Do not use any type of alcohol under **any** circumstances.

Permitted cleaning agents and disinfectants for the Large Display and protective screen

are listed in the "Operator Instructions" or in the "Supplement to the Operator Instructions".

Installing/Removing the Protective Screen on the Large Display:

1. Hook the protective screen onto the top edge of the Large Display.
2. Then use magnetic strips to secure the bottom edge of the screen to the LD.
3. If the protective screen is removed, proceed in the reverse sequence.

Fig. 23: LD Plexiglas protective screen

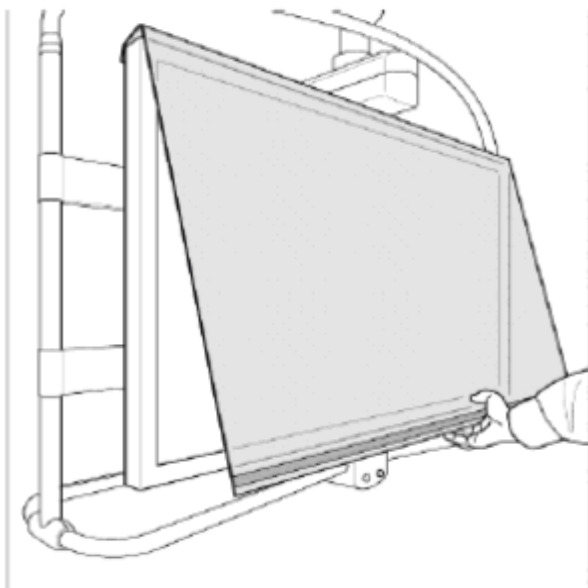

Also see the Retrofit Instructions. (→ Protective shield for the Large Display / TD00-LD1.814.05)



A counterweight for the protective screen is expected as of January 2014.

Once the counterweight (part no. 108 48 687) is there, the counterweight can be optimally readjusted.

2.8.6.3 Electrical Safety

SIE Cables and Connectors

1. Check visible cables and connectors for damage.



The Large Display has a non-removable (permanently connected) power connection.

2.9 Cockpit

2.9.1 Special Requirements

2.9.1.1 Required Documents

- If there are brightness/contrast problems, see the CB-DOC document system > Service > Monitors > Artis zee Cockpit > Adjustment.

2.9.1.2 Product-specific Safety Information



The safety information in the customer's Operator Manual must be observed for all activities on the system.

2.9.2 Mechanical Safety

2.9.2.1 Visual Inspection of Exterior

PMP Damage

1. Check the display for damage, e.g. for damage to the housing.

2.9.3 Inspection and Maintenance

2.9.3.1 TFT Display

QSQ Brightness and Contrast

Perform brightness/contrast checks/measurements per the Artis zee Cockpit (9x) Adjustment Instructions.

For the Artis zee VC14 SW, see: (→ Artis zee System SW VC14 / TD00-LD2.842.01)

For the Artis zee VC21/VD11 SW, see: TD00-LD2.842.02.....(→ Adjusting the Lab Cockpit / TD00-LD2.842.02)

1. Open the "**Administrator User Interface (Configuration)**" on the **Artis zee Cockpit** display:

For the VC14 SW: (→ Configuraton > Administrator User Interface / TD00-LD2.842.01)

For the VC21/VD11 SW: (→ Opening the Administrator User Interface (Configuration) / TD00-LD2.840.01)

To do so, proceed as follows:

- a) The mouse pointer must be placed in the top status bar (edge of frame is green) in one of the windows.

- b) Simultaneously press the **left "Shift"** key and the **"Delete"** key on the keyboard to open the Administrator level.
 - » The **"Administration"** window will open.
2. Open/select the test pattern in the **"Administration"** window.

With SW VC14: (→ Selecting test pattern images / TD00-LD2.842.02)

With SW VC21/VD11: (→ Selecting test pattern images / TD00-LD2.842.02)

To do so, proceed as follows:

 - a) "Select **Configuration**" > **"General Settings"** > **"Testpattern"**.
 - b) Double-click on **"Master"**.
 - » The **"Master"** test pattern for check/adjustment will be displayed on the entire panel area as a "full screen".
 - » **NOTE:** To close the "full screen" again, click on the test pattern again.
3. The following values must be measurable using the SMFit test meter (→ SMFit test instrument to measure luminance / TD00-LD1.814.01):

Type	max. brightness 100%(white field)	max. brightness 0% (black area)
MX300	180 ±15 cd/m ²	0,4 ±0.15 cd/m ²
RX430	400 ±40 cd/m ²	0,65 ±0.15 cd/m ²
DSC3012	400 ± 40 cd/m ²	0.5 ± 0.15cd/m ²

- » If the tolerance value is exceeded, perform an adjustment, see the Configuration/Adjustment Instructions....
 For the VC14 SW: (→ Display Configuration / Adjustment / TD00-LD2.842.01)
 For the VC21/VD11 SW:(→ Configuration / Adjustment / TD00-LD2.842.02)).

2.9.3.2 Cockpit Controller



One Cockpit Controller is always configured to which 2 workplaces, each with one TFT display, can be connected
 The 2nd workplace with TFT display is optional.

PMP Checking / Cleaning the Fan

1. Check the **MLC_Front_Fan** on the controller for function, unusual operating noise and for dirt; if needed, clean it.
 Error message: **AX_MLC 2**

2. Check the function of the fan **MLC_MDI_FAN** on the inside of the controller by reading out the fan rpm monitor.

This fan is checked and cleaned only if a corresponding error message appears in the event log.

Error message **AX_MLC 3**



Error message **AX_MLC 004** means **over temperature**.

PMP Replacing the Cockpit Controller BIOS Battery (36-month interval)

1. Depending on the Cockpit Controller hardware version, the BIOS battery has to be replaced every 3 years. The replacement for the material numbers affected is described here: (→ Replacing the BIOS Battery / TD00-LD2.841.01).

2.9.4 Upkeep

PMP Cleaning the Cockpit



The display housing is made of plastic. To remove any residue, do not use any sharp objects or fluids that can melt plastic such as acetone, ether, solvent, trichloro-hydrocarbons, etc., see the approved cleaning agents (→ Tab. 7 Page 188).



The information regarding cleaning agents absolutely must be observed.

See: (→ Cleaning the Large Display, Cockpit and TFT Monitor / Page 188)

If the listed agents are not used, the panel surface will be irretrievably damaged.

Cleaning agents may not remain on the surface for an extended period.

If this is not observed, the warranty is invalidated.

Equipment Care, Cleaning and Disinfection:

1. The front of the display is very sensitive to mechanical damage; absolutely avoid scratches, shocks, etc.
2. Promptly remove any drops of liquid that fall on it; extended contact with liquids may cause, for example, discoloration or calcium outlines on the surface.
3. If there is dirt on the front of the display, clean it with a microfiber cloth and if necessary with a cleaning agent. Clean housing components only with the recommended cleaning agents.
4. If a cleaning agent is sprayed directly on the display surface, make sure that any droplets that run down are wiped off with a microfiber cloth before they reach the edge of the panel.

5. For permissible cleaning agents, see the system Operator Manual

2.9.5 Final Work Steps

2.9.5.1 Electrical Safety

SIE Cables and Connectors

1. Check visible cables and connectors for damage.



The Cockpit has a non-removable (permanently connected) power connection.

2.10 TFT Monitor

2.10.1 Special Requirements



Do not test the monitors in the ECG system, e.g. AXIOM Sensis according to this document; for this, see the document for the particular ECG system.

Reason: The ECG system monitors are connected to the ECG system or to an "external power outlet" and therefore cannot be measured against the ground wire bus rail for the X-ray system.

2.10.2 Product-specific Information



Perform the following maintenance activities for any optional and all 18/19" TFT displays in the control room and DCS.

2.10.3 Mechanical Safety

2.10.3.1 Visual Inspection of Exterior

PMP Damage

1. Check the display for damage, e.g. for damage to the housing.

2.10.3.2 Mount

SIM Display Mount

Visual inspection:

The Vesa mounting plates (4x) must be flat on the display, they may not be bent up; visually check, see (→ 4/ Fig. 24 Page 55).

Fig. 24: Visual check of the adapter

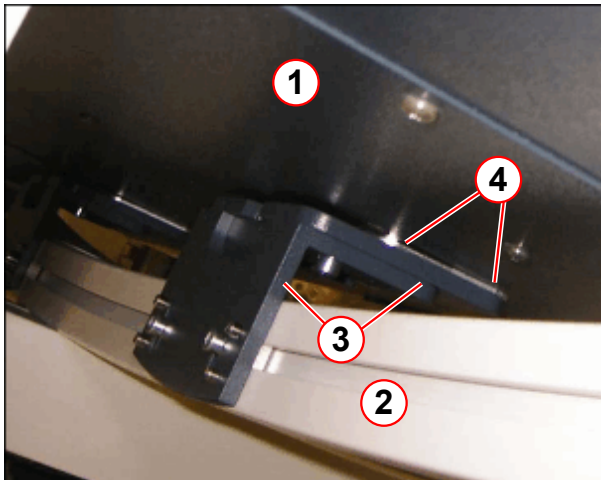

- (1) Display
- (2) DCS
- (3) Vesa adapter
- (4) Placement of the Vesa adapter on the display

Check of screw tightness:



Using a torque wrench, check that the 4 screws securing the display (display \Leftrightarrow DCS) are tight to 15 Nm.

The two "top" mounting screws are checked with the 6 mm Allen wrench, see (\rightarrow 1, 3, 4, 5/ Fig. 25 Page 55).

The two "bottom" mounting screws are checked with the 13 mm open-end wrench, see (\rightarrow 1, 2/ Fig. 25 Page 55).

Fig. 25: Torque wrench with 6 mm Allen wrench and 13 mm open-end wrench

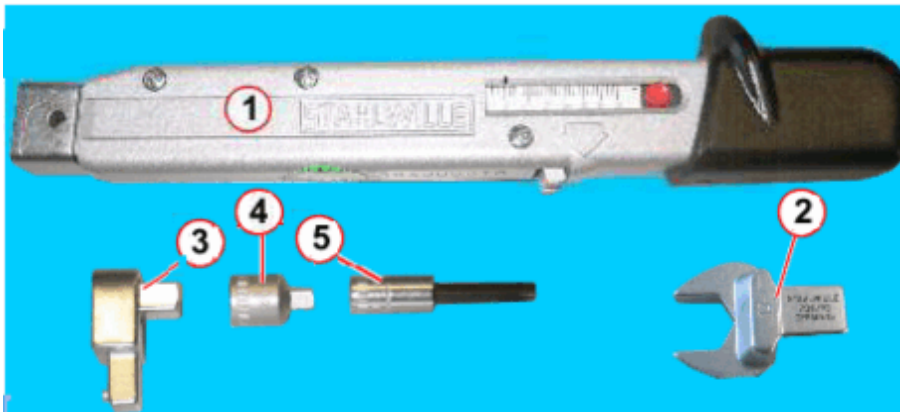

- (1) Torque wrench 8 to 40 Nm (99 00 846)
- (2) 13 mm open-end wrench attachment (component of 80 86 159)
- (3) 3/8" adapter attachment for torque wrench (70 58 928)
- (4) 3/8" to 1/4" adapter (component of 81 59 980)
- (5) 6 mm hex attachment 1/4" (component of 97 02 457)

2.10.4 Electrical Safety

SIE Cables and Connectors

1. Check the visible cables and connectors of the TFT monitor for damage

2.10.5 Inspection and Maintenance

QSQ Brightness and Contrast

1. Check the brightness and contrast on the TFT monitor per the TFT monitor document "Replacement of Parts", see the system CB-DOC > Service > Monitors.

2.10.6 Upkeep

PMP Cleaning the TFT Monitor

1. Disconnect the monitor from line power (system power off) and wipe down with a damp cloth, see:(→ Tab. 7 Page 188). The approved cleaning agents are also listed in the System Operator Manual.



The monitor housing is made of plastic. To remove any residue, do not use any sharp objects or fluids that can melt plastic such as acetone, ether, solvent, trichloro-hydrocarbons, etc., see the approved cleaning agents (→ Cleaning Information / Page 188).



The information regarding cleaning agents absolutely must be observed.
See:(→ Tab. 7 Page 188)
If the listed agents are not used, the surface will be irretrievably damaged.
Cleaning agents may not remain on the surface for an extended period.
If this is not observed, the warranty is invalidated.

2.11 Final Work Steps

2.11.1 Installing the Cover Panels

1. Reinstall all cover panels that were removed.

2.11.2 Electrical Safety, Ground Wire Check

2.11.2.1 General information regarding ground wire testing as per IEC 62353

General Statement regarding the definition of "removable / non-removable (fixed) power connection":

■ **Non-removable power connection:**

Non-removable (permanently connected) means to be connected electrically with the power supply system using a permanent connection that can be disconnected only with a tool. A power connection cable that, for example, is secured to the monitor against being pulled out (falling out) by a cable tie or that is secured against being pulled out by a mechanical cover (19" B/W with a cover over the connections) is referred to as a fixed power connection.

- In **permanently connected** ME devices (here, **monitors**), the ground wire connection to the power supply must be tested. The resistance between the ground wire connection of the ME device and the ground-wire-connected, conductible parts of the device that can be touched and that can conduct voltage in a malfunction situation, must not exceed **300 mΩ** (always observe country-specific regulations). No ground wires should be disconnected during the test.

■ **Removable power connection:**

Monitors from which the power connector can be unplugged without mechanical means are referred to as a non-permanent power connection. When doing this, for measurement with the separate measurement of the ground wire, perform the measurement directly in the power connector to the central grounding point as well as the single measurement from the ground wire input contact on the monitor to all metal parts of the monitor.

- With a **removable power line connection** to the ME device (here, **monitors**), the ground wire resistance of the complete path (cable and device) to the ground-wire-connected, conductible parts of the ME device that can be touched must not exceed **200 mΩ**. For the **removable power line connection** itself, resistance between the ground wire contacts at each end may not exceed **100 mΩ**. Removable power line cables to other devices that may be used must also be measured.

General measurement procedure:

Test the ground wire resistance between all conductible parts of the system that can be touched and the ground wire bus rail (in the generator, power distributor, for example).

Fig. 26: Ground wire measurement with fixed power line connection

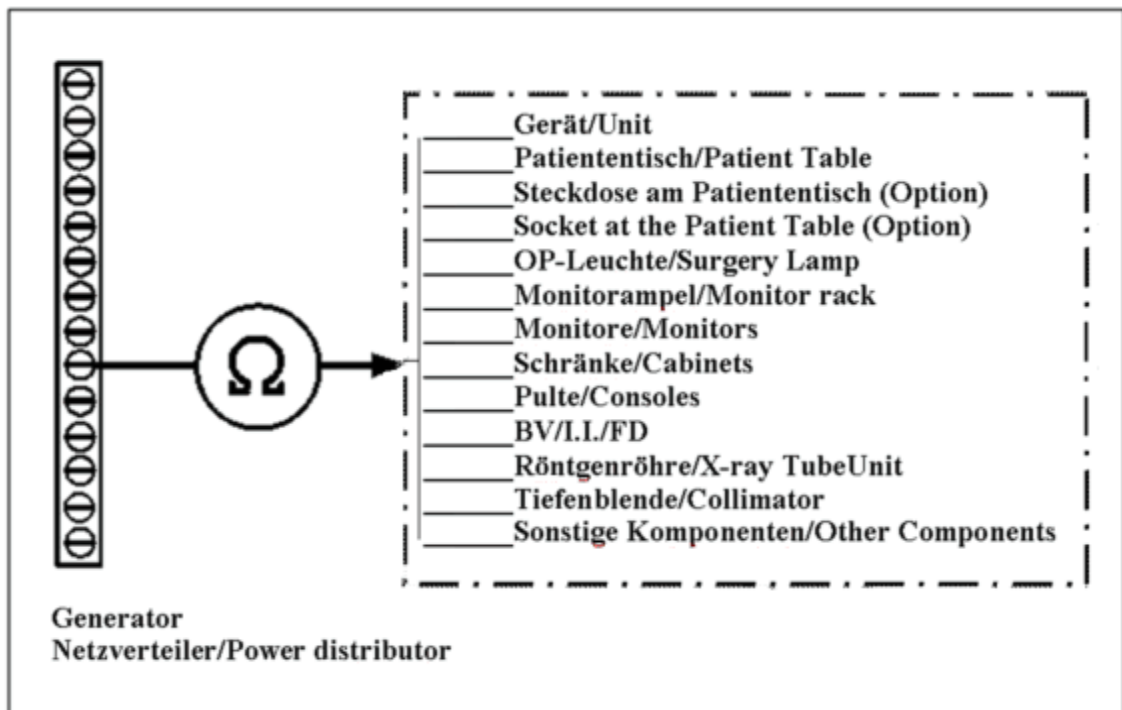

According to IEC 62353, the measured values from the old maintenance certificates as well as the startup certificate from the initial maintenance must be compared with the new measured values. If a significant difference is found or if the measured value exceeds **300 mΩ**, initiate corrective measures. Usually, the problem is that the ground wires are not connected or are incorrectly connected.



DANGER

Risk of accident due to electric shock!

- » Correct any incorrect ground wire connections prior to turning the unit over to the customer.

2.11.2.2 Ground Wire Testing for the Image System

1. Switch off power to the system.
2. Measure the resistance between an exposed, conducting part on the image system container and the ground wire bus rail in the power distributor.
3. Record the value in the maintenance certificate.



SIE Image system ground wire test ($\leq 300 \text{ m}\Omega$)

2.11.2.3 Foot switch ground wire test (cable connection)

1. Switch off power to the system.

2. Measure the resistance between an exposed, conducting part on the foot switch and the ground wire bus rail in the power distributor.



3. Record the value in the maintenance certificate.

SIE Foot switch ground wire test ($\leq 300 \text{ m}\Omega$)

2.11.2.4 Large display ground wire testing (optional)

1. Switch off power to the system.
2. Measure the resistance between an exposed, conducting part on the large display and the ground wire bus rail in the power distributor.



3. Record the value in the maintenance certificate.

SIE Ground wire test, Large Display 1 ($\leq 300 \text{ m}\Omega$)

SIE Ground wire test, Large Display 2 ($\leq 300 \text{ m}\Omega$)

2.11.2.5 Ground wire measurement, cockpit display (optional)

1. Switch off power to the system.
2. Measure the resistance between an exposed, conducting part on the cockpit display and the ground wire bus rail in the power distributor.



3. Record the value in the maintenance certificate.

SIE Ground wire test, Cockpit Display 1 ($\leq 300 \text{ m}\Omega$)

SIE Ground wire test, Cockpit Display 2 ($\leq 300 \text{ m}\Omega$)

2.11.2.6 Ground wire measurement, TFT monitors

1. Switch off power to the system.
2. Measure the resistance between an exposed, conducting part on the TFT monitor and the ground wire bus rail in the power distributor.



3. Record the value in the maintenance certificate.

- SIE** Ground wire test, TFT Monitor 1 ($\leq 300 \text{ m}\Omega$)
- SIE** Ground wire test, TFT Monitor 2 ($\leq 300 \text{ m}\Omega$)
- SIE** Ground wire test, TFT Monitor 3 ($\leq 300 \text{ m}\Omega$)
- SIE** Ground wire test, TFT Monitor 4 ($\leq 300 \text{ m}\Omega$)
- SIE** Ground wire test, TFT Monitor 5 ($\leq 300 \text{ m}\Omega$)
- SIE** Ground wire test, TFT Monitor 6 ($\leq 300 \text{ m}\Omega$)
- SIE** Ground wire test, TFT Monitor 7 ($\leq 300 \text{ m}\Omega$)
- SIE** Ground wire test, TFT Monitor 8 ($\leq 300 \text{ m}\Omega$)
- SIE** Ground wire test, TFT Monitor 9 ($\leq 300 \text{ m}\Omega$)
- SIE** Ground wire test, TFT Monitor 10 ($\leq 300 \text{ m}\Omega$)
- SIE** Ground wire test, TFT Monitor 11 ($\leq 300 \text{ m}\Omega$)
- SIE** Ground wire test, TFT Monitor 12 ($\leq 300 \text{ m}\Omega$)



Mandatory:

The ground wire test according to IEC 62353 absolutely must be performed at the end of the maintenance call before the system is turned back over the customer for patient operation.

This applies regardless of whether or not all planned maintenance points for this partial maintenance have been completed.

3.1 Special Requirements

3.1.1 Required Documents

- CB-DOC Artis zee, AXA4-000.803.02....

3.1.2 Required Tools, Test Equipment and Aids

- Standard toolkit 9702457
- Fluke 287 digital multimeter 9994831
- or
Multimeter, measurement range 1 to 20 Volt DC, accuracy at least 1%. n.a.
- Protective ground wire test meter This test meter, for example the general-purpose test meter, must meet the specifications of IEC 61557/EN 61557/VDE 0413/IEC 62353.
SECUTEST® SIII or PROFITEST® 0100S-II (→ Order directly / Page 187)
- or
Safety Analyser Rigel 62353 230V 10848526
Safety Analyser Rigel 62353 130V 10848527
- or
Rigel 288 Order directly from Rigel
- or
Fluke ESA 612 / ESA 615 Order directly from Fluke
- Digital dosimeter, e.g.
DIADOS 9717612
- or
Unfors Xi Unfors, direct order
- ESD equipment 9702606
- Lint-free cleaning cloths n.a.
- Brush to remove dust n.a.
- Antistatic vacuum cleaner with nozzle (observe country-specific regulations) n.a.
- Precision filter (2.1 mm Cu) 9900598

- | | |
|---|--------------------|
| ■ Torque wrench, 20 Nm to 100 Nm (3/8") with
3/8" to 1/2" adapter (socket) | 4430906
4430914 |
| or | |
| Torque wrench, 20 Nm to 100 Nm (1/2"), tolerance ±
4% | n.a. |

All tools, test equipment and aids listed with a part number can be ordered from the Service Parts Catalogue (SPC).

3.1.3 Required Materials

For generator and cooling unit:



In biplane systems, these parts are needed two times!

- | | |
|--|----------|
| ■ Two silicon disks, 3-pole, for Claymount high voltage cables with white connectors | 10093772 |
| ■ Two silicon disks, 4-pole for Claymount high voltage cables with white connectors | 10093773 |
| ■ 2x silicon oil | 1787035 |
| ■ Only if needed 2x gasket | 11270317 |
| ■ Klüver/Laird cooling unit filter sieve | 10390318 |
| ■ Klüver/Laird cooling unit filter (external) | 11270288 |
| or | |
| ■ Lytron cooling unit filter/strainer (kit) | 11270284 |
| ■ Cooling unit Klüver/Laird pump kit (maintenance interval, 24 months) | 11253350 |
| or | |
| ■ Cooling unit Lytron pump kit (maintenance interval, 36 months) | 11270283 |

For the support arm system:

- | | |
|---|---------|
| ■ Cleaning agent for plastic, glass and painted parts, e.g., Hakapur concentrated cleaner (500 g) | 9660648 |
| ■ Alcohol | n.a. |

Paints to touch up chips/scratches in the paint finish:

- | | |
|---------------------|---------|
| ■ White (spray can) | 8427734 |
|---------------------|---------|

- White textured (paint stick) 3444403
- Medical Blue (spray can)¹ 5507046
- Medical Blue (paint stick)² 5507087

1. Color: light blue

2. Color: light blue

3.1.4 Required Work Time/Maintenance Interval, Biplane System

Component	Required Work Time/Maintenance Interval
X-ray Generator, Plane A	2 hrs./12 months or 3 hrs./24 months
X-ray Generator, Plane B	2 hrs./12 months or 3 hrs./24 months
Support Arm System (Radiation Shield, Injector Head...) (optional)	1 hour / 12 months
Total Work Time, Partial Maintenance 2:	5.0 hrs./12 months or 7.0 hrs./24 months

3.2 X-ray Generator

3.2.1 Safety

SI Tube Unit Displays



1. Check the function of the radiation displays on the monitor trolley system (MTS), on the monitor carriage or on the DCS To do this, trigger a scene in both the fluoroscopy mode and the exposure mode.

- » The yellow radiation displays must go on during the time in which radiation is triggered and must be clearly visible.



2. Check the function of the external radiation displays (if configured). To do this, trigger a scene in both the fluoroscopy and exposure modes.

- » The yellow radiation display lamps must visibly light up so that they are clearly visible for the time in which radiation is triggered.



3. Check the function of the audio messages for high contrast fluoroscopy. This function depends on the configuration of the system controller (SYC) **Audible Warnings** and the system configuration "Select Group To Configure" **Parameters of group XRay (ANG)**.

- » An audible signal sounds if the patient entrance dose can exceed 10 R/min. or always when fluoroscopy is with high contrast, depending on the configuration.



4. Check the function of the audio signals for exposure end. To do this, trigger a scene or a single image in an exposure mode. This function depends on the configuration of the system controller (SYC) **Audible Warnings**.

- » An audible signal sounds at the end of an exposure or scene.



5. Check the function of the fluoroscopy timer (fluoro timer). This function depends on the configuration of the system controller (SYC) **Audible Warnings**.

- » If the fluoroscopy time is exceeded, an audible signal sounds. Radiation is not aborted.

3.2.2 Preventive Maintenance

3.2.2.1 Power cabinet

PMP Clean the power cabinet

1. Remove any dirt and dust from the chassis, power supply, boards and fans.

3.2.2.2 High voltage connections

PMP Check the high voltage connections

1. Checking for Damage to the High Voltage Cables

High voltage cables that can be touched must be covered with a non-conductive material that protects the shielding against mechanical damage when there is proper use.

- » Conformance must be checked by a visual check.

2. Checking the Shielding of the High Voltage Cables

The high voltage cables that can be touched and that conduct the tube current must be provided with a flexible, conductive shielding that has a maximum resistance of 1 Ohm/m. The shielding must be connected to both the metal housing of the X-ray generator as well as to the X-ray tube unit.



With the POLYDOROS A100, Part No. 7462570 and A100 Plus, Part No. 10563420, the high voltage cable length is shortened approx. 1 m because the shielding for the high voltage cables are connected to housing ground in the power cabinet!

- » Conformance must be checked by a measurement. Pull the high voltage cables out of the tube unit sockets and measure the shielding braid versus protective ground. High voltage cables whose shielding braid exceeds a resistance of max. 1 Ohm/m must be replaced.

3. Cleaning the Tube Unit Sockets

- a) Clean the tube unit high voltage sockets with a dry, lint-free cloth or paper towels. When doing this, perform a visual check of the high voltage sockets for damage and for traces of high voltage arcing.

4. Cleaning the High Voltage Connectors

- a) Clean the high voltage sockets with a dry, lint-free cloth or paper towels. When doing this, perform a visual check of the high voltage connectors for damage and for traces of high voltage arcing.

5. Replacing and Lubricating the Silicon Disk in the Tube Unit

- a) Evenly apply silicon oil using only the tip of the tube on the front of the high voltage connector. Then place on the silicon disk and moisten it with silicon oil.



When shipped, the tube of silicon oil is not completely filled. The entire contents of the tube must be applied in equal parts to the high voltage connectors.

6. Connecting the High Voltage Connectors to the Tube Unit

- a) Line up the guide nib on the high voltage connector with the slot on the socket and carefully insert the connector into the socket.
- b) Hand-tighten the mounting ring.
- c) After about one hour, check the tightness of the mounting ring.
- d) Turn the securing screw into the mounting ring until it is against the contact ring, thus preventing unwanted loosening of the mounting ring.

7. Connecting the High Voltage Connectors to the High Voltage Transformer

- a) With the POLYDOROS A100, Part # 7462570, and the A100 Plus, Part # 10563420, the high voltage connectors are inserted **with the silicon disk** with silicon oil and without the sealer ring. Evenly apply silicon oil using only the tip of the tube on the front of the high voltage connector. Then place on the silicon disk and moisten it with silicon oil. Line up the guide nib on the high voltage connector with the slot on the high voltage socket and carefully insert the high voltage connector into the socket.

8. Tightening the High Voltage Connectors

- a) Secure the mounting ring with the safety screw, thus preventing unwanted loosening of the mounting ring.

3.2.2.3 Cooling unit

Fig. 27: Klüber/Laird Cooling Unit

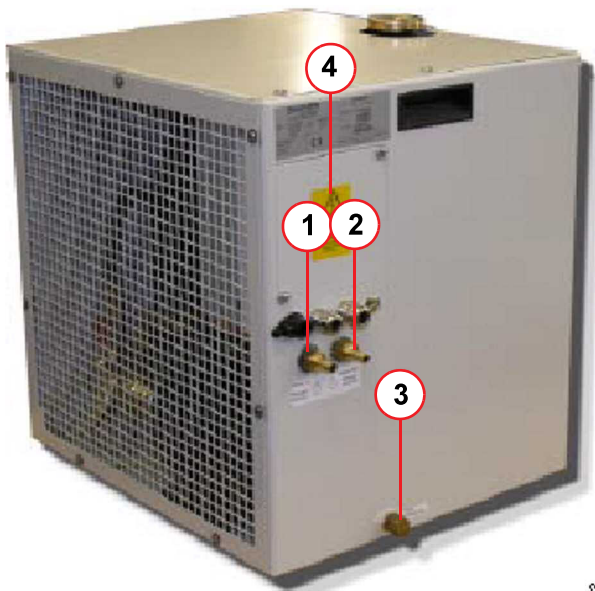

- (1) CS.IN cooling hose
- (2) CS.OUT cooling hose
- (3) Sealer cap
- (4) Controller board cover

Fig. 28: Lytron cooling unit

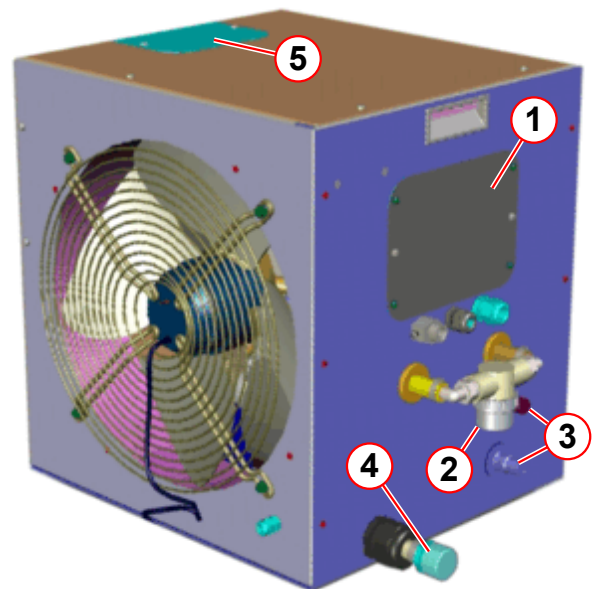

- (1) Control board
- (2) Filter
- (3) Cooling hose
- (4) Drain screw
- (5) Fill pipe

Checking the Cooling Hoses for Damage

- Check the cooling hoses for damage at the tube unit and cooling unit with a visual check.

PMP Check the cooling hoses

Klüber/Laird cooling unit: Replace the pump head (every 24 months)

- See the detailed Replacement Instructions in the document AX71-020.841.01.....

Klüber/Laird cooling unit under: (→ Replacing the Pump Head, Part No.: 11253350 / AX71-020.841.01)

PMP Klüver/Laird cooling unit: Replace the pump head (every 24 months)

Lytron cooling unit: Replace the pump head (every 36 months)

- See the detailed Replacement Instructions in the document AX71-020.841.01.....

Lytron cooling unit under:(→ Replacing the Pump Head, Part No.: 11270283 / AX71-020.841.01)

PMP Lytron cooling unit: Replace the pump head (every 36 months)

Klüver/Laird and Lytron cooling unit: Replace filter sieve

- See the detailed Replacement Instructions in the document AX71-020.841.01.....

Klüver/Laird cooling unitunder: (→ Replacing the Sieve, Part No.: 10390318 / AX71-020.841.01).

Lytron cooling unit under: (→ Replacing the filter insert / AX71-020.841.01).

PMP Replace filter sieve

Klüver/Laird and Lytron cooling unit: Replace external filter

- Refer to the detailed replacement instructions in document AX71–020.841.01.....

Klüver/Laird cooling unitunder: (→ Replacing the external filter, part no.: 11270288 / AX71-020.841.01).

Lytron cooling unit under: (→ Replacing the external filter, part no.: 11270288 / AX71-020.841.01).

PMP Replace external filter

Filling the Tube Unit Cooling System

- See detailed instructions in the document AX71–020.841.01...

Klüver/Laird cooling unitunder: (→ Startup / AX71-020.841.01)

Lytron cooling unit under:(→ Startup / AX71-020.841.01)



Do **not** use distilled water.

The cooling unit may never be operated without water, otherwise the pump will be damaged.

PMP Add cooling water

Check the Function of the Cooling Unit.

- Remove the cover on the controller board, if needed.
- Press the S1 button (Klüver/Laird) or the Service button (Lytron).
 - » The cooling unit fan and pump are switched on.

PMP Check the function of the cooling unit.

Checking the Oil Pump Motor Current Monitor

- Disconnect the cable to the X1.1 terminal in the cooling unit.
 - » A delayed "continuous sounding" warning signal sounds on the MEGALIX tube unit.



The X-ray tube may not be hot at this time, otherwise they can be damaged!
No radiation may have been performed in the last 20 minutes and/or 0% HU, the tube is then cool.

2. Reconnect the cable to the X1.1 terminal in the cooling unit and reinstall the cover panels that were removed.

3.2.2.4 Tube Adjustment

PMP Perform Tube Adjustment

See the Adjustment Instructions.

VC14 SW: AXA4-0100.842.12..... (→ X-ray tube adjustment / AXA4-100.842.12)

VC20/21 SW and VD11 SW: AXA4-PAP.842.01..... (→ X-ray Tube Adjustment / AXA4-PAP.842.01)

1. Select the X-ray tube adjustment on the following path in the service program: **Tune Up > System Adjustment - Tube**.
2. Perform the "Adjustment Preparation" instructions in the "Tube Adjustment" window and then click on "Go".
 - » A new "Tube Adjustment" window appears.
3. Select the desired adjustment/s. To do this, set a checkmark for the Checkbox/en for Generator A and/or Generator B.
4. "Click on **Go**" to start the selected adjustment/s. If both generators are selected for bi-plane systems, the adjustment takes place one after the other (Plane A then B).

3.2.3 Checking the Operating Parameters

3.2.3.1 Quick check: dose area product

QIQ Quick check: dose area product Perform annually.

1. Set the area dose product display (CAREwatch) to "0" by selecting a new patient on the system.
2. Set the following parameters under **Local Service>Control>Control Acquisition**:
Focus: large, **CU Filter:** 0, **Voltage:** 70 kV, **Current:** 200 mA, **Pulse Width:** 100 ms (= 20 mAs).
3. Trigger an exposure with **Start X-Ray**.
4. Record the dose area product shown on the CAREwatch display.
5. Ensure that the radiation field area does not change.
6. Under Control Acquisition set **Current** to: 400 mA (= 40 mAs). Trigger a second exposure.
7. Record the dose area product shown on the CAREwatch display.



8. Compare both values that were noted.
 - » The second value must be twice as large.
Tolerance: $\pm 25\%$

3.2.3.2 Technical measurement check: dose area product



According to manufacturer and legal regulations, the measurement-technical check is mandatory every 5 years.

QIQ Technical measurement check: Perform every 5 years

Test set-up:

Fig. 29: Test set-up

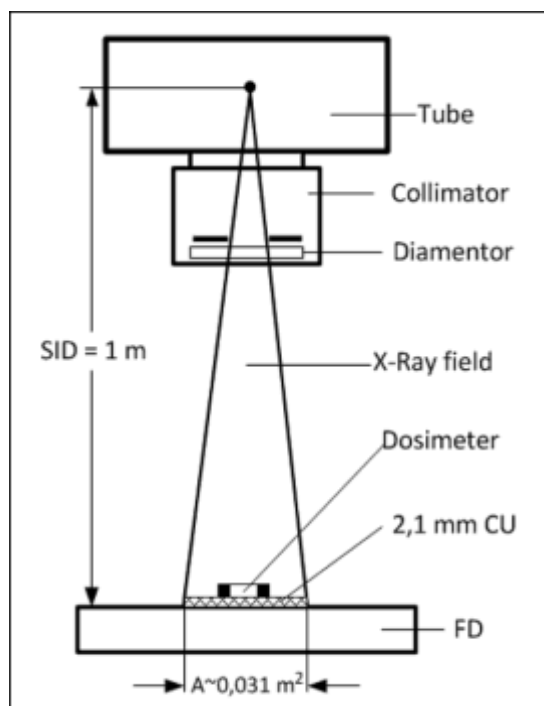

The dose area product (DAP) can be determined at any level of the radiation cone; however, when this is done, it is necessary that the dose and the radiation field area be determined on one and the same plane.

Required Aids:

- Precision filter (2.1 mm Cu), P/N 9900598 for overlaying on an exact area of 310 cm^2 (0.031 m^2).
- Dose meter (Diados, Unfors).

- Tape for attaching the 2.1 mm Cu filter and the dose meter chamber to the FD collision protection.

Tab. 2 Abbreviations used:

DAP	Dose area product
DAP _d	Dose area product _d = displayed
DAP _c	Dose area product _c = calculated
D	Measured dose
A	Radiation field area (m ²)

Test preparation:

1. Set the SID to 100 cm.
2. Under fluoroscopy, center and place the precision filter (2.1 mm, Cu) on the FD collision protection housing.
3. Overlay the radiation field precisely onto the precision filter (2.1 mm, Cu).
 - » When overlaid onto the filter precisely, the radiation field area (A) is 0.031 m².
4. Center and place the dose meter chamber on the precision filter (2.1 mm, Cu).
5. Ensure that the radiation field area does not change.
6. Record the dose area product shown on the CAREwatch display.



Performing the test:

1. Set the following parameters under **Local Service>Control>Control Acquisition**:
Focus: large, **CU Filter:** 0, **Voltage:** 70 kV, **Current:** 200 mA, **Pulse Width:** 100 ms (= 20 mAs).
2. Trigger an exposure with **Start X-Ray**.
3. Record the dose area product shown on the CAREwatch display.
4. Subtract the previously recorded value (in step 6 above) from the dose area product displayed
 and log the result (**DAP_d**)
5. Read and record the dose value measured (**D**) on the dosimeter.
6. Calculate and record the dose area product (**DAP_c**).
 Formula: **DAP_c = D x A** (A = 0.031 m² when the precision filter has been overlaid precisely)



QIQ Dose area product: Displayed value (DAP_d)

QIQ Dose area product: Value measured (DAP_c)

Test evaluation:

1. Calculate the difference between the displayed and measured dose area product.

Tab. 3 Formula:

$$\text{Difference in \%} = \frac{(DAP_d - DAP_c) \times 100}{DAP_c}$$

2. The CAREwatch display shows values in $\mu\text{G}/\text{m}^2$. Depending on the dosimeter used, value conversion may be required:

Conversion factors:						
1 $\mu\text{G}/\text{m}^2$	=	10 mGy/cm^2	=	10,000 $\mu\text{G}/\text{cm}^2$	=	1 cGy/cm^2
1 R/m^2	=	8.7 mGy/cm^2	=	8,700 $\mu\text{G}/\text{cm}^2$	=	0.87 cGy/cm^2



3. Record the difference.



If the difference is less than or equal to $\pm 30\%$, the (Diamentor) tester is within specifications.

QIQ The (Diamentor) DAP test area meets specifications (deviation $< \pm 30\%$).

3.3 Support Arm System (Radiation Shield, Injector Head...)

3.3.1 Safety Inspection

SIM Checking the Mounting Screws of the Ceiling Rails



1. Check the mounting screws for tightness $25 \text{ Nm} \pm 5 \text{ Nm}$.

PMP Mechanical Check

1. Inspect the ceiling stands, carriages and support arms for damage.

Fig. 30: Support arm, not with Portegra2

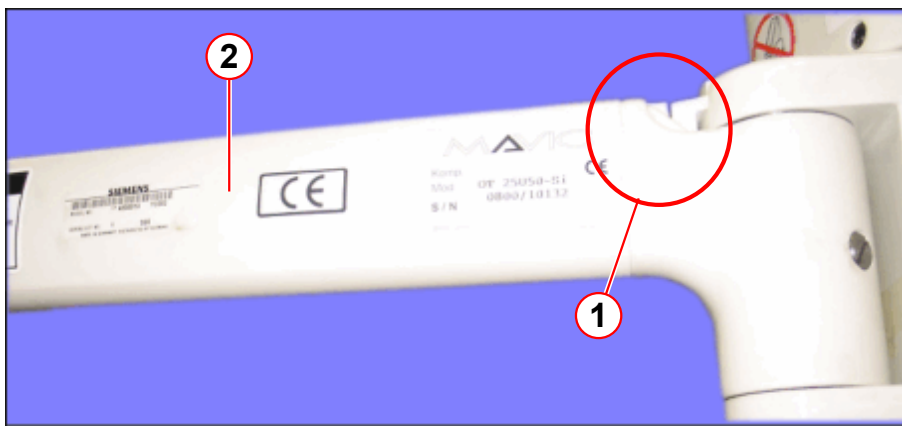

- (1) Checking for damage
- (2) Checking the whole support arm for collision damage

CAUTION

If previous damage cannot be ruled out, this can cause the support arm to break.

» In particular, inspect the support arm for signs of collisions, for example paint flaking, hairline cracks (→ 1/Fig. 30 Page 73) and other damage.

2. Check the stops on the ceiling rails.
3. Check the bearings in the carriages.
4. Check the function of the carriage longitudinal brake.
5. Check the lift and rotation movements and the weight compensation of the support arms.
6. Check the surgery lamp for function, mounting, mechanical condition.
7. Check the cable guide to the injector head (option).

SI Check the collision labels for legibility.

3.3.2 Cleaning

QSQ Clean the contact surfaces of the ceiling rails.

3.4 Final Work Steps

3.4.1 Installing the Cover Panels

1. Reinstall all cover panels that were removed.

3.4.2 Electrical Safety, Ground Wire Check

3.4.2.1 General information regarding ground wire testing as per IEC 62353

General measurement procedure:

Test the ground wire resistance between all conductible parts of the system that can be touched and the ground wire bus rail (in the generator, power distributor, for example).

Fig. 31: Ground wire measurement with fixed power line connection

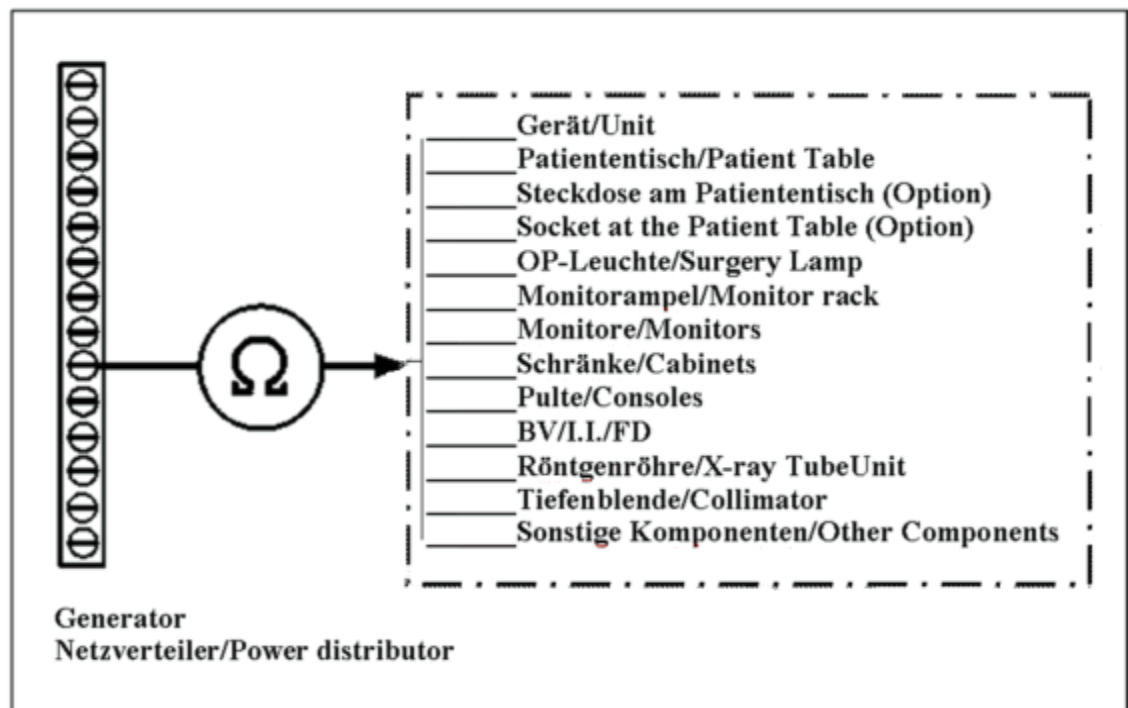

According to IEC 62353, the measured values from the old maintenance certificates as well as the startup certificate from the initial maintenance must be compared with the new measured values. If a significant difference is found or if the measured value exceeds **300 mΩ**, initiate corrective measures. Usually, the problem is that the ground wires are not connected or are incorrectly connected.

 **DANGER**

Risk of accident due to electric shock!

- » Correct any improper ground wire connections prior to turning the unit over to the customer.

3.4.2.2 Ground wire measurement for generators

1. Switch off power to the system.
2. Measure the resistance between an exposed, conducting part on the generator A/B cabinet and the ground wire bus rail in the power distributor.
3. Record the value in the maintenance certificate.



SIE Ground wire test, Generator A ($\leq 300 \text{ m}\Omega$)

SIE Ground wire test, Generator B ($\leq 300 \text{ m}\Omega$)

3.4.2.3 Ground wire measurement for X-ray tube cooling unit

1. Switch off power to the system.
2. Measure the resistance between an exposed, conducting part on the X-ray tube cooling unit A/B and the ground wire bus rail in the power distributor.



Special case: the cooling unit is not in the control room.

If the cooling unit is located in a room that cannot be physically accessed (for example, on a mezzanine floor), an additional measuring cable is available from the system distributor to the cooling unit for systems shipped in 2015 and onwards. This measuring cable (cross section: 10mm) has an inherent resistance of **50 m Ω** (this value must be taken into consideration when taking the measurement). The measuring cable is provided exclusively for the ground wire measurement on the system distributor and must only be used for this measurement.

 **CAUTION**

If the additional ground wire measuring cable is connected in the wrong manner, a short circuit can occur.

Short circuit!

- » Only connect the measuring cable at the specified locations!



3. Record the value in the maintenance certificate.

SIE Ground wire test for the X-ray tube cooling unit A ($\leq 300 \text{ m}\Omega$)

SIE Ground wire test for the X-ray tube cooling unit B ($\leq 300 \text{ m}\Omega$)

3.4.2.4 Ground wire measurement for the support arm system

1. Switch off power to the system.
2. Measure the resistance between an exposed, conducting part on the support arm system and the ground wire bus rail in the power distributor.
3. Record the value in the maintenance certificate.



SIE Ground wire test for support arm system ($\leq 300 \text{ m}\Omega$)



Mandatory:

The ground wire test according to IEC 62353 absolutely must be performed at the end of the maintenance call before the system is turned back over the customer for patient operation.

This applies regardless of whether or not all planned maintenance points for this partial maintenance have been completed.

4.1 Special Requirements

4.1.1 Required Documents

- CB-DOC Artis zee, AXA4-000.803.02....

4.1.2 Required Tools, Test Equipment and Aids

- Standard toolkit 9702457
- Fluke 287 digital multimeter 9994831
- or
Multimeter, measurement range 1 to 20 Volt DC, accuracy at least 1%. n.a.
- Protective ground wire test meter This test meter, for example the general-purpose test meter, must meet the specifications of IEC 61557/EN 61557/VDE 0413/IEC 62353.
SECUTEST® SIII or PROFITEST® 0100S-II (→ Order directly / Page 187)
- or
Safety Analyser Rigel 62353 230V 10848526
Safety Analyser Rigel 62353 130V 10848527
- or
Rigel 288 Order directly from Rigel
- or
Fluke ESA 612 / ESA 615 Order directly from Fluke
- ESD equipment 9702606
- Antistatic vacuum cleaner with nozzle (observe country-specific regulations) n.a.
- Lint-free cleaning cloths n.a.
- Brush to apply grease n.a.
- Brush to remove dust n.a.
- Torque wrench, 20 Nm to 100 Nm (3/8" drive) with 3/8" to 1/2" adapter (socket) 4430906
4430914
- or
Torque wrench, 20 Nm to 100 Nm (1/2" drive), tolerance $\pm 4\%$, calibrated n.a.

All tools, test equipment and aids listed with a part number can be ordered from the Service Parts Catalogue (SPC).

For the FD Laser Crosshair (optional)

- | | |
|--|----------|
| ■ Service or installation tool kit | n.a. |
| - 2.5 Allen wrench with ball end | |
| ■ Laser phantom | 10501897 |
| - Shipped with the system or with the option | |
| - Can be found in the system Technical Documents binder, Register 9. | |

4.1.3 Required Materials

For the floor stand:

- | | |
|--|---------|
| ■ Cleaning Agents and Rust Protection for Rails
e.g. WD40 contact spray (spray can, 400 g), | 2870061 |
| ■ GLEITMO 805K (400 g cartridge) | 6311968 |
| ■ Longtime PD2 (20 g tube) | 3491271 |
| or Longtime PD2 (1 kg) | 7395445 |
| (Pressurized grease for long-term lubrication of bearing cages,
open ball bearings, chains, steel cables, etc.) | |
| ■ Cleaning agent for plastic, glass and painted parts
e.g. Hakapur concentrated cleaner (500 g), | 9660648 |
| ■ Alcohol | n.a. |
| ■ Tonna S68 oil (for the lubricators, e.g. C-Arm), (200 ml) | 8126430 |
| Only if needed Grease fitting | 6221837 |
| ■ Only if needed Green Lamp | 6974059 |

For Universal Collimator:

- | | |
|---|----------|
| ■ Spare parts kits, medical white (24-month maintenance interval) | 11192198 |
|---|----------|

Paints to touch up chips/scratches in the paint finish:

- | | |
|--------------------------------|---------|
| ■ White (spray can) | 8427734 |
| ■ White textured (paint stick) | 3444403 |

- Medical Blue (spray can)¹ 5507046
- Medical Blue (paint stick)² 5507087

-
1. Color: light blue
 2. Color: light blue

4.1.4 Work Time/Maintenance Interval

Component	Required Work Time/Maintenance Interval
Floor Stand	5 hours / 12 months
FD Laser Crosshair (optional)	10 minutes / 12 months
Universal Collimator	10 minutes / 24 months
Total Work Time, Partial Maintenance 3:	5.16 hrs/12 months, 5.33 hrs/24 months

4.2 Floor Stand

4.2.1 Mechanical Safety

4.2.1.1 Stand Base

1. Remove the covers from the stand column.
 - Mark the locations of the mounting screws used on the stand base and on the cover panels.

There are several possible ways to install them, but only one is correct.

SIM Stand base mounting



1. Check that the 6 nuts (→ 1/ Fig. 32 Page 82) are securely tightened:
Torque: 52 ± 5 Nm.

Fig. 32: Stand base

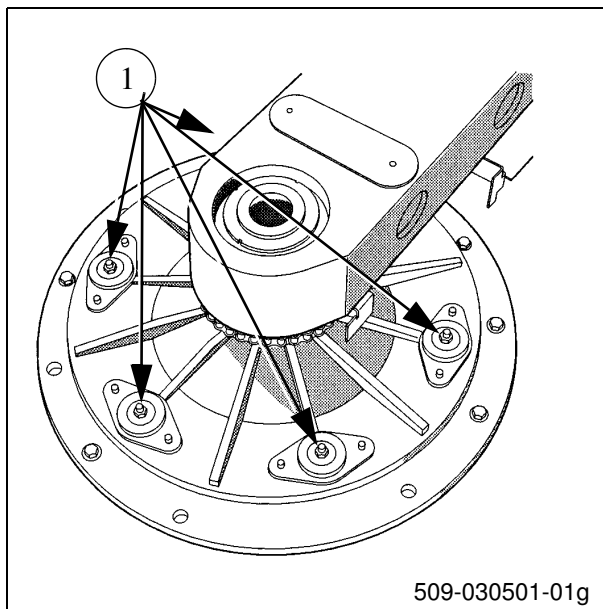

4.2.1.2 Rotation Movement

SIM Motor Mount

1. Ensure that the 6 screws to mount the motor (→ 1/ Fig. 33 Page 83) are securely tightened.
Torque: 25 ± 2.5 Nm.



Fig. 33: Rotation motor

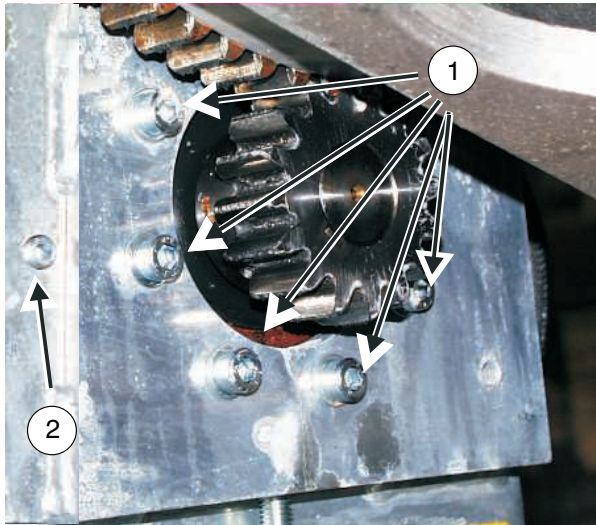

4.2.1.3 C-Arm

SIM C-Arm mount

1. Ensure that the mounting screws for the C-Arm motor (→ 1/Fig. 34 Page 83) are securely tightened.

Fig. 34: Orbital motor

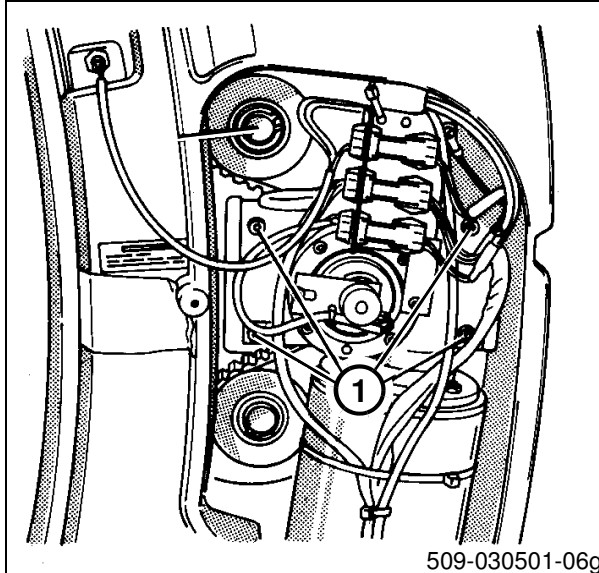

SIM C-Arm bearing mount

1. Ensure that the mount for the C-Arm bearings (→ 1/Fig. 35 Page 84) is securely installed.

SIM C-Arm guide, condition/damage

1. Subject the C-Arm guide (→ 2/ Fig. 35 Page 84) to a visual inspection for any damage.

Fig. 35: C-Arm; bearings and guides

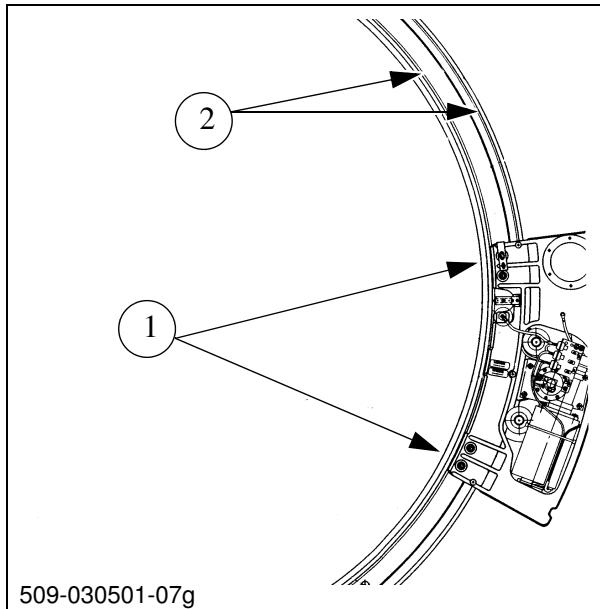
**SIM** Toothed belts, damage

1. Check the toothed belt (→ 1/ Fig. 36 Page 84) for good condition.

Fig. 36: Toothed belt, check

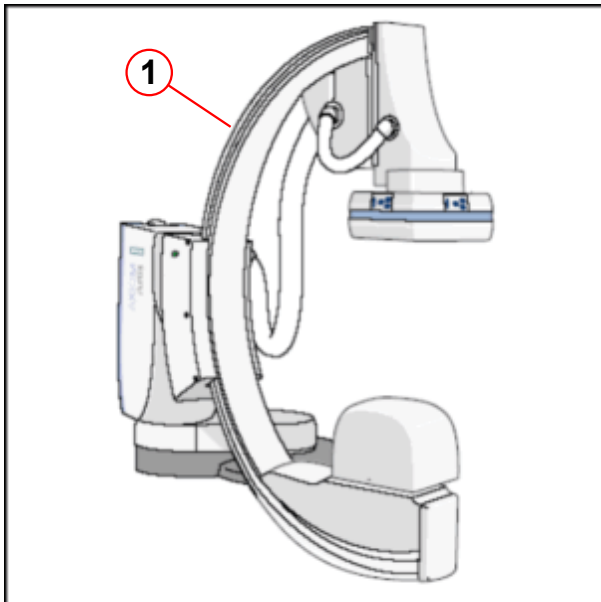

4.2.2 Electrical Safety, Safety Devices

4.2.2.1 Electrical Isolation

SIE Isolated Installation, Dirt

To ensure that there is isolated installation, the Dynavision plate (→ 1/Fig. 37 Page 85) may not have contact with the floor, which can be caused by dirt or other objects.

1. Clean the gap between the Dynavision plate and the floor (→ 1/Fig. 37 Page 85) and remove any foreign objects.

Fig. 37: Dynavision plate

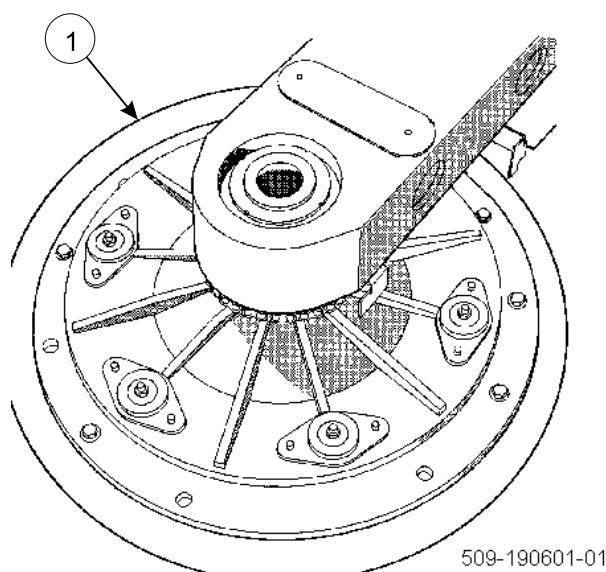

4.2.2.2 Checking the Floor Stand Pivot Position

SIE Stand Position Switches, Function

The gas spring (→ 1/Fig. 38 Page 86) is used only for soft stopping of the unit in the particular end position.

1. The final position is defined by the mechanical end stop (→ 2, 3/Fig. 38 Page 86). When it is reached, these bumpers (→ Fig. 38 Page 86) should be compressed approx. 1 mm.

Fig. 38: Gas piston spring

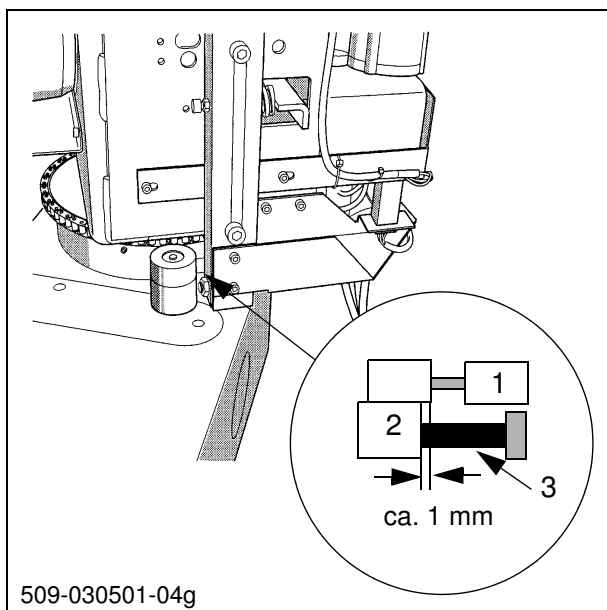

Make sure that when the particular end position is reached, the stand moves into the end stop softly and at minimum speed.

If movement into the end position is too hard, proceed according to the linearity adjustment for this axis, per the Artis Floor and Biplane Stands Adjustment Instructions, AXA4-050.842.01.... (→ Linearity Adjustment - Floor stand / AXA4-050.842.01)

4.2.2.3 DMG Function

SIE Dead man's switch, function

1. Select **<Test Tools> <Stand and Table Tests> <DMG and Quick Stop Test>** in the service interface.
2. Deflect the joystick for any unit movement of the floor stand (e.g. orbital, angulation movement) without pressing it axially:
 - » No unit movement is possible.
3. Deflect the joystick axially and laterally:
 - » The selected movement is performed.

- The DMG status of the corresponding unit movement must switch from OFF" to "ON" and the counter must increase one digit.

Fig. 39: DMG and Quick Stop Check

Test Tools			
Test Tools	DMG and Quickstop Check		
	Adjustment Duration	:	
	Adjustment Status	: Running	
	Runtime message sent by component	:	
	Runtime Data		
		Status	Counter
	DMG ULI 1	: Off	0
	DMG ULI 2	: Off	0
	DMG ULI 3	: Off	0
	DMG MCD	: Off	0
	EMGY ULI 1	: Off	0
	EMGY ULI 2	: Off	0
	EMGY ULI 3	: Off	0
EMGY MCD	: Off	0	
Quickstop ULI	: Off	0	
Quickstop MCD	: Off	0	
Quickstop Aux	: Off	0	
Quickstop MTS	: Off	0	

4.2.2.4 Limit Switches, Functions

SIE C-Arm safety limit switch, function

SIE Rotation movement limit switch, function

- Select <Test Tools> <Stand and Table Tests> <End Limit Switch Check>.
 - » The following service window is displayed:

Fig. 40: End Limit Switch Check, Floor Stand

Test Tools	
End Limit Switch Check, Floor Stand	
Adjustment Duration	:
Adjustment Status	: Running
Runtime message sent by component	:
Runtime Data	
End Limit switch	: Low end High end
C-arm rotational A	: --- 0 --- 0
C-arm orbital	: --- 0 --- 0
Receptor lift A	: --- 0 --- 0
Base rotation A	: --- 0 --- 0
Table transversal	: --- 0 --- 0
Table longitudinal	: --- 0 --- 0
Table lift	: --- 0 --- 0
Table rotation	: --- 0 --- 0
Table tilt	: --- 0 --- 0
Collimator rotation A	: --- 0 --- 0
Camera rotation A	: --- 0 --- 0
Gantry rotation A	: --- 0 --- 0
Table cradle	: not configured

The limit switches for the various axes can be checked using this test.

The hardware limit switches may be moved into at slow speed because the software limits (software switches) are not active in this mode.

Move into the end position for the axis that is to be checked. When the software limit switch is reached, the SCU stops movement.

Then press the buttons on the SCM (Prog 1 and Prog 2 buttons) at the same time (simultaneously) and continue movement at slow speed until the hardware limit switch is reached. When the end switch is reached, the flag in the service window changes from inactive to active and the counter is increased by 1.

4.2.2.5 Contact Safety Device

SIE Contact safety switches, function

Fig. 41: Contact safety switch

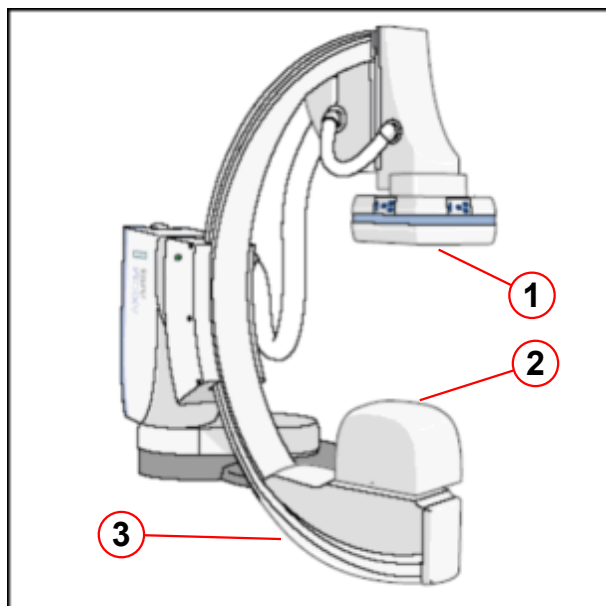

1. Select <Test Tools> <Stand and Table Tests> <Proximity Switch Check>.
2. Perform any unit movement (Orbital, Angulation movement).
3. Operate the following contact safety switches, one after the other:
 - on the detector(→ 1/Fig. 41 Page 89)
 - on the collimator (→ 2/Fig. 41 Page 89)
 - the switch strip on the C-Arm (→ 3/Fig. 41 Page 89)
 - » The unit movement must be interrupted.
 - » The display "FD Guard active....." must appear on the DDIS.

4.2.2.6 Emergency Stop Function

SIE Testing EMERGENCY STOP

1. Check the emergency stop function at the various operating locations. To do this, press the emergency stop buttons on:
 - Examination room control modules
 - Control room emergency stop (optional)
 - » All motorized movements must be interrupted.
2. Perform an orbital movement at maximum speed:
 - Press the EMERGENCY OFF switch on the control console.
 - » The unit must stop immediately.

3. Perform the same tests for all axes.

4.2.3 Maintenance

4.2.3.1 Cleaning and Lubricating the Rotation Drive

PMP Cleaning and Lubricating the Rotation Drive

Fig. 42: Rotation motor

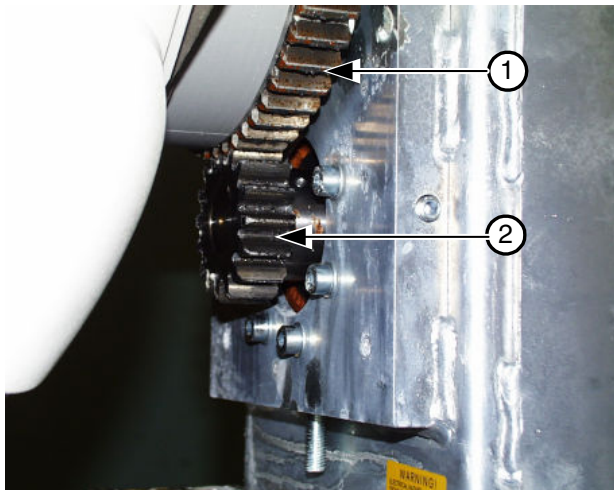

System part	Cleaning	Lubricants
Rotation movement: The large (→ 1/Fig. 42 Page 90) and the small pinion gear (→ 2/Fig. 42 Page 90) must be lubricated.	With a lint-free cloth	GLEITMO 805K

4.2.3.2 Cleaning and Lubricating the C-Arm

PMP Cleaning and Lubricating the C-Arm

Fig. 43: C-Arm; bearings and guides

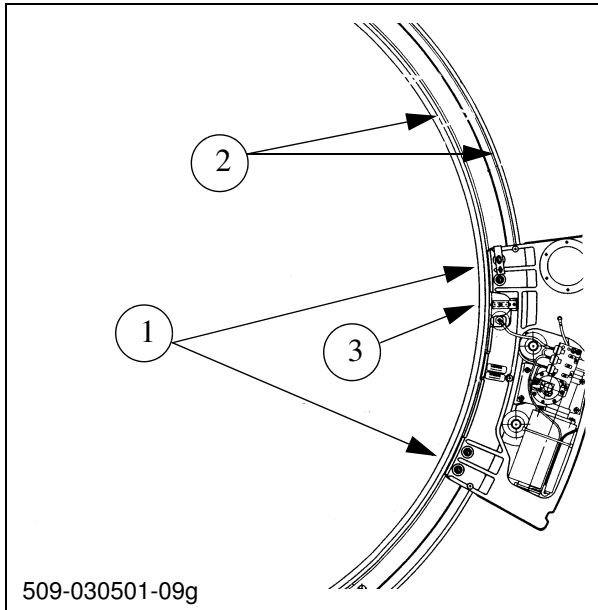

System part	Cleaning	Lubricants
C-Arm: Gear contact surfaces (→ 1/Fig. 43 Page 91) Guide (→ 2/Fig. 43 Page 91) Guide lubrication locations (→ 3/Fig. 43 Page 91)	Wipe dry with a lint-free cloth.	Tonna S68 ¹ .

1. Only if necessary: Replace the grease fitting/s

4.2.3.3 Cleaning and Lubricating the FD Receptor

PMP Cleaning and Lubricating the FD Receptor

Fig. 44: Receptor

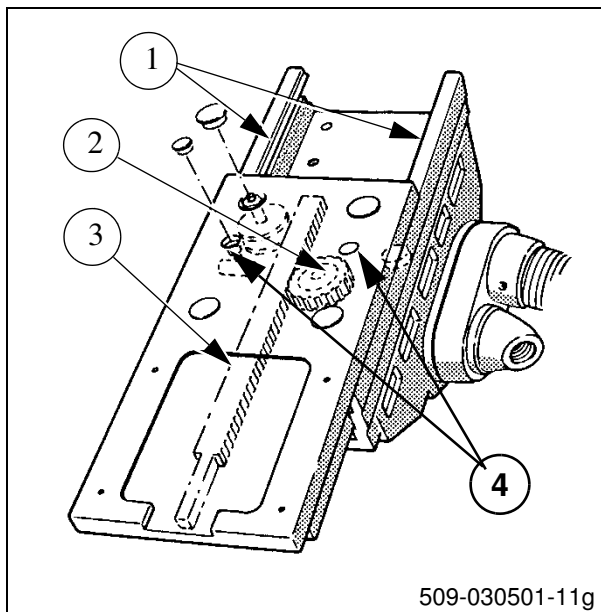

System part	Cleaning	Lubricants
FD receptor: Contact rails (→ 1/Fig. 44 Page 92) Drive sprocket (→ 2/Fig. 44 Page 92) Drive rail (→ 3/Fig. 44 Page 92) Contact rail lubrication locations ¹ (→ 4/Fig. 44 Page 92)	Wipe dry with a lint-free cloth.	Tonna S68

1. Remove the plastic caps and Allen screws under them and drip approx. 5 to 10 drops of Tonna S68 oil through the holes. Then reinsert the Allen screws and caps and move the receptor several times fully to the ends in both directions. Oil may only wet the rails. Excess oil may not drip and, if necessary, must be removed.

4.2.3.4 Lubricating and Cleaning the Pivot Arm Chain

PMP Cleaning and lubricating the pivot arm chain

Fig. 45: Pivot arm chains

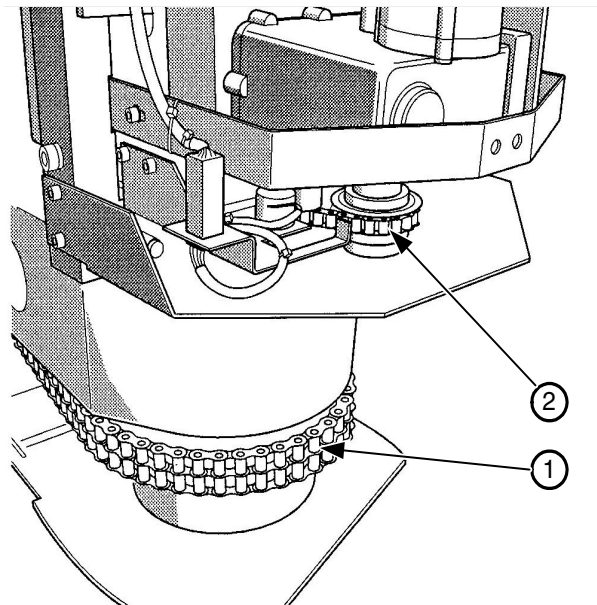

System part	Cleaning	Lubricants
Stand rotation: Double chain (→ 1/Fig. 45 Page 93) Chain (→ 2/Fig. 45 Page 93)		LONGTIME PD2



Only lightly lubricate the chain (→ 1/Fig. 45 Page 93).

4.2.3.5 Corrugated Hoses

PMP Corrugated hoses, cables; damage

Fig. 46:

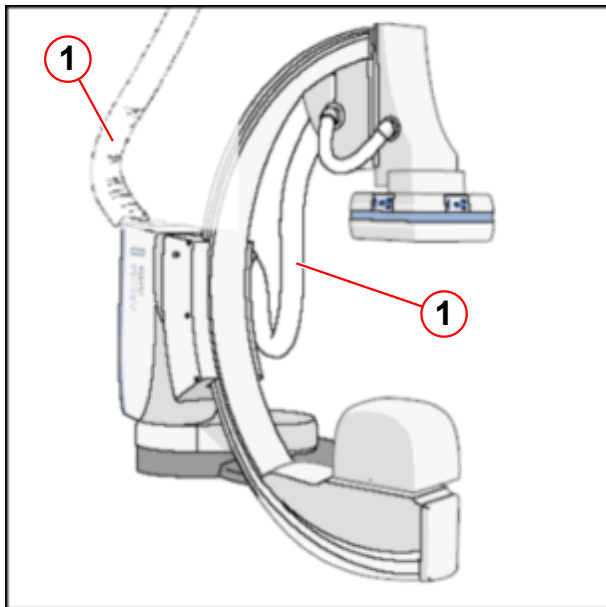

1. Check the cables and corrugated hoses for damage (→ 1/ Fig. 46 Page 94).

4.2.4 Operating Values, Inspection

4.2.4.1 Checking in the Service Mask

PMP Reading out the error list

1. Select the event log, enter "AX_SCU*" in the "source name" box and read out the service-relevant AX_SCU errors.

PMA Incremental sensor/potentiometer difference

1. Select C-Arm rotation, C-Arm orbital movement, receptor lift, base rotation, collimator rotation, camera rotation over the entire range:
 - » The difference between the incremental sensor and the potentiometer value may not exceed 5 degrees (this can be checked using **<Test tools> <Stand and Table Tests> <Position Check>**). No further potentiometer or encoder errors (e.g. AX_SCU_ERR_1101) may appear in the event log. If a potentiometer or encoder-related value appears, perform a potentiometer adjustment for this axis.

PMP AD Converter, check

1. Select **<Test Tools> <Stand and Table Tests> <Position Check, Floor - Stand>**.

2. Select C-Arm rotation, C-Arm orbital movement, receptor lift, base rotation, collimator rotation, FD rotation over the entire range:
 - » The active axis must change the potentiometer AD value and the encoder value.

PMA 0 degree setting, check

1. Move C-Arm rotation, C-Arm orbital movement into the 0 degree position.
2. Use a spirit level to check the setting.
3. If there is a difference, perform **<Tune Up> <Stand> <End Position Adjustment, Floor Stand>** . (→ End Position Adjustment / AXA4-050.842.01)

PMP Power supply (5 V), Check

1. Select **<Test Tools><Stand and Table Test><Digital Inputs, MCU Boards> and <A/D Channels, MCU Board>** and check the 5 V internal, 5 V for encoder motors 1&2 and 5 V for encoder motors 3&4.

4.2.5 Function Inspection

4.2.5.1 Checking the Unit Functions

PMP Control console, unit functions

1. Check the functions of the SCM (Stand Control Module), for example:
 - a) LAO and RAO
 - b) Cranial and Caudal
 - c) FD Lift (Receptor) UP/DOWN
 - d) Base pivoting, Plane A and manual rotation (option), if configured.
 - e) FD Rotation and Collimator Rotation
 - f) Simultaneous Movement of Planes A + B
 - g) Automap
 - h) Pre-Program Positions (1 or 2 attempts)
 - i) Direct Positions (attempt)
 - j) System positions
 - k) 0 Position Functions (centering movement)

4.2.6 Final Work Steps

4.2.6.1 Replacing the Green Signal Lamp

PMP Replacing the signal lamp

1. If needed, replace the green lamp on the C-Arm.



Make absolutely sure to insulate the electrical connections. Otherwise there is a risk of a short circuit (fuse will trip).

4.2.6.2 Installing the Cover Panels on the Unit

1. Reinstall all cover panels that were removed.

4.2.6.3 Clean equipment, repair any damage to painted surfaces

PMP Clean equipment, repair any damage to painted surfaces

1. Clean the unit as well as the cables and corrugated hoses.
2. If necessary, touch up chips/scratches in the paint finish.

4.2.6.4 Electrical Safety

SIE Cables and Connectors

1. Check visible cables and connectors for damage.

4.3 Universal collimator (24 months)

4.3.1 Periodic Preventive Maintenance

4.3.1.1 Replacing the Air Filter (Universal Collimator delivered >2014)

PMP Replacing the Air Filter (Universal Collimator delivered >2014)

1. The air filter in the universal collimator must be replaced periodically - every **24 months**.



None of the cover panels on the collimator need to be removed during maintenance!

2. Loosen the screw (→ 1/ Fig. 47 Page 97).

Fig. 47: Loosen the holder screw

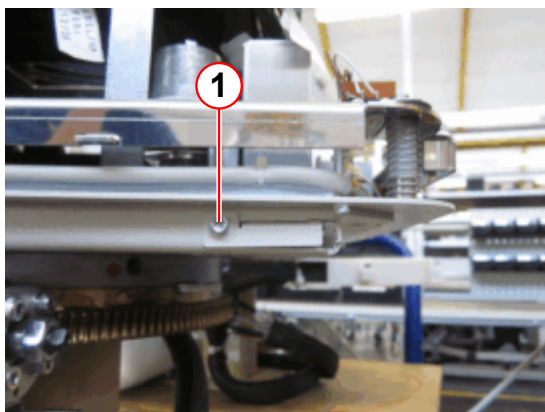

(1) Loosen the screw (ISO4762, M3x6)

3. Manually pull out the air filter insert from the holder.

Fig. 48: Pull out the air filter insert

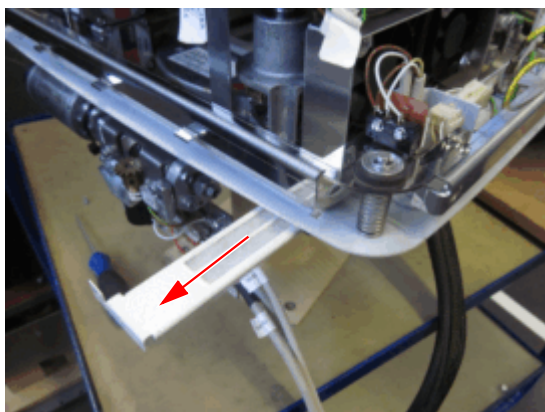

4. Replace the old air filter pad with the new air filter pad.

5. Reinsert the air filter pad into the holder.

Fig. 49: Insert in the air filter holder

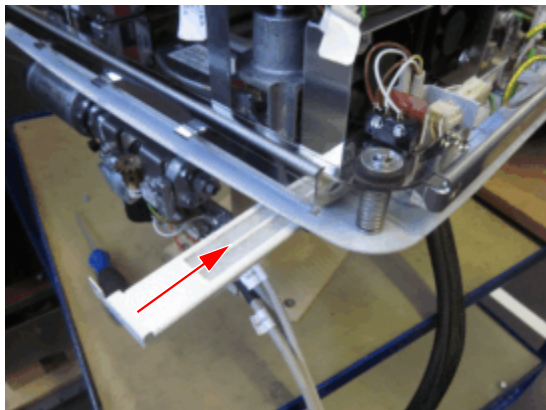

6. Retighten the screw (→ 1/ Fig. 50 Page 98).

Fig. 50: Tighten the holder screw

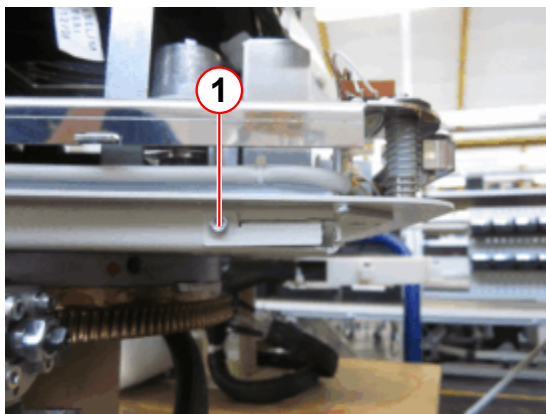

(1) Tighten the screw (ISO4762, M3x6)

4.4 Laser Crosshair FD (Laser Light) Option

4.4.1 Product-specific Safety Information

hm_serv_LaserSightEvalMaintenance.

Adjustment of the laser light must be checked during maintenance.



The Laser Crosshair FD (FD laser light) option uses two modules with Class 1M lasers.

Class 1M lasers are safe, except when used together with optical aids such as binoculars, telescope, focusing lenses, etc.

4.4.2 Mechanical Safety

SIM FD Detector Laser Crosshair Covers

1. Check the cover of the Laser Crosshair FD for whether they are mechanically secured and undamaged.

4.4.3 Maintenance

PMP Cleaning the Laser Crosshair FD

1. Carefully clean the covers of Laser Crosshair FD detector. When doing this, remove contrast medium residue, etc. and make sure that the laser optics of the two laser modules are not soiled.

4.4.4 Function Inspection

PMF Checking Functions and Adjustment

hm_serv_LaserSightEvalMaintenance.

Check the function and adjustment of the FD laser crosshair.

The instructions for this are located in the document Artis zee, Adjustment, Laser Crosshair, Laser Crosshair, VC14 SW, AXA4-000.842.18..... in the chapter "Procedures".
(→ Function Check / AXA4-000.842.18)

If the phantom is out of tolerance, it is absolutely necessary that a new adjustment be performed.

4.5 Final Work Steps

4.5.1 Installing the Cover Panels

1. Reinstall all cover panels that were removed.

4.5.2 Electrical Safety, Ground Wire Check

4.5.2.1 General information regarding ground wire testing as per IEC 62353

General measurement procedure:

Test the ground wire resistance between all conductible parts of the system that can be touched and the ground wire bus rail (in the generator, power distributor, for example).

Fig. 51: Ground wire measurement with fixed power line connection

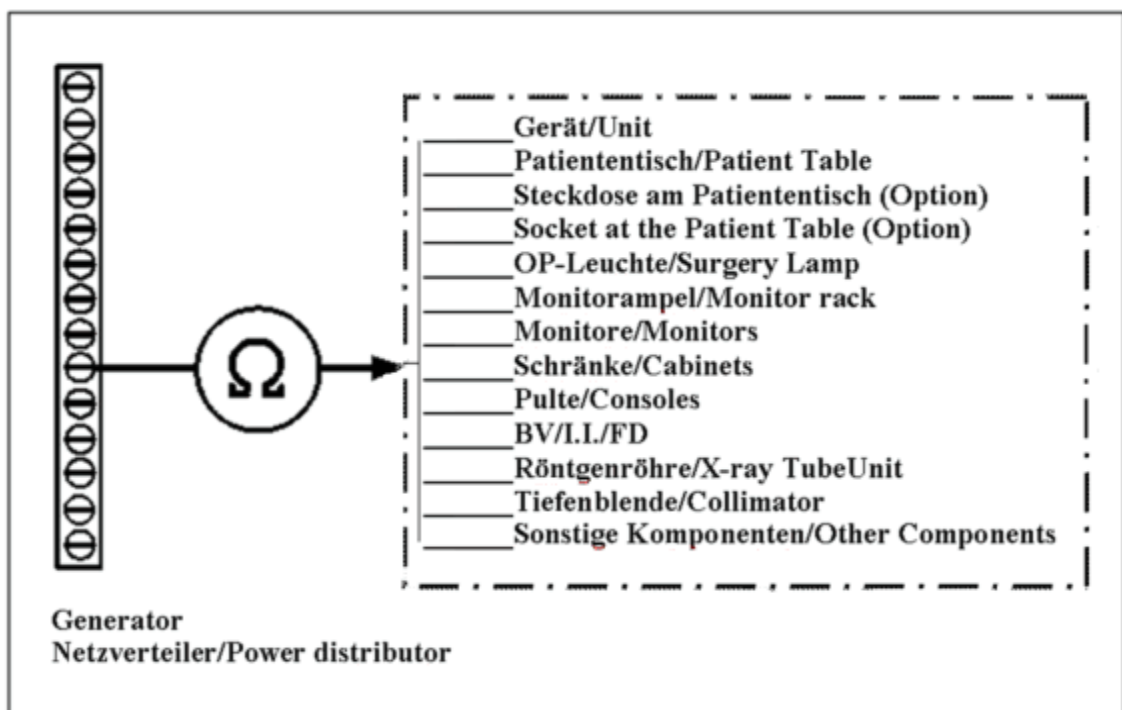

According to IEC 62353, the measured values from the old maintenance certificates as well as the startup certificate from the initial maintenance must be compared with the new measured values. If a significant difference is found or if the measured value exceeds **300 m Ω** , initiate corrective measures. Usually, the problem is that the ground wires are not connected or are incorrectly connected.

**DANGER**

Risk of injury due to electric shock!

- » Correct any incorrect ground wire connections prior to turning the unit over to the customer.

4.5.2.2 Ground wire measurement for the floor stand

1. Switch off power to the system.
2. Measure the resistance between an exposed, conducting part on the floor stand and the ground wire bus rail in the power distributor.
3. Record the value in the maintenance certificate.



SIE Ground wire measurement for the floor stand ($\leq 300 \text{ m}\Omega$)

4.5.2.3 Ground wire test for laser crosshair (FD cover)

1. Switch off power to the system.
2. Measure the resistance between an exposed, conducting part on the FD cover and the ground wire bus rail in the power distributor.
3. Record the value in the maintenance certificate.



SIE Ground wire test for laser crosshair (FD cover) ($\leq 300 \text{ m}\Omega$)

4.5.2.4 Ground wire measurement for the collimator

1. Switch off power to the system.
2. Measure the resistance between an exposed, conducting part on the collimator and the ground wire bus rail in the power distributor.
3. Record the value in the maintenance certificate.



SIE Ground wire test for the collimator ($\leq 300 \text{ m}\Omega$)



Mandatory:

The ground wire test according to IEC 62353 absolutely must be performed at the end of the maintenance call before the system is turned back over the customer for patient operation.

This applies regardless of whether or not all planned maintenance points for this partial maintenance have been completed.

5.1 Special Requirements

5.1.1 Required Documents

- CB-DOC Artis zee, AXA4-000.803.02....

5.1.2 Required Tools, Test Equipment and Aids

- Standard toolkit 9702457
- Fluke 287 digital multimeter 9994831
- or
Multimeter, measurement range 1 to 20 Volt DC, accuracy at least 1%. n.a.
- Protective ground wire test meter This test meter, for example the general-purpose test meter, must meet the specifications of IEC 61557/EN 61557/VDE 0413/IEC 62353.
SECUTEST® SIII or PROFITEST® 0100S-II (→ Order directly / Page 187)
- or
Safety Analyser Rigel 62353 230V 10848526
Safety Analyser Rigel 62353 130V 10848527
- or
Rigel 288 n.a.
- or
Fluke ESA 612 / ESA 615 n.a.
- ESD equipment 9702606
- Antistatic vacuum cleaner with nozzle (observe country-specific regulations) n.a.
- Lint-free cleaning cloths n.a.
- Brush to apply grease n.a.
- Brush to remove dust n.a.
- Torque wrench, 20 Nm to 100 Nm (3/8" drive) with 3/8" to 1/2" adapter (socket) 4430906
4430914
- or
Torque wrench, 20 Nm to 100 Nm (1/2" drive), tolerance ± 4 %, calibrated n.a.

- | | |
|---|---------|
| ▪ 8mm Allen wrench (1/2" hex attachment), no ball end
(for DCS) | 5266531 |
| ▪ Spring balance, 0 - 25 N (for DCS) | 4429114 |
| ▪ Stepladder
for working in the area of the ceiling (if needed, borrow on
site) | n.a. |

All tools, test equipment and aids listed with a part number can be ordered from the Service Parts Catalogue (SPC).

5.1.3 Required Materials

For floor stand and DCS:

- | | |
|--|---------|
| ▪ Cleaning agents and rust protection for rails
E.g., WD-40 contact spray (spray can, 400 g) | 2870061 |
| ▪ GLEITMO 805K (400 g cartridge) | 6311968 |
| ▪ Viscogen KL 300, 50 ml (for steel cables and chains) | 7279107 |
| ▪ Longtime PD2 (20 g tube) | 3491271 |
| or Longtime PD2 (1 kg) | 7395445 |
| (Pressurized grease for long-term lubrication of bearing cages,
open ball bearings, chains, steel cables, etc.) | |
| ▪ Cleaning agent for plastic, glass and painted parts
e.g. Hakapur concentrated cleaner (500 g), | 9660648 |
| ▪ Alcohol | n.a. |
| ▪ Tonna S68 oil (for the lubricators, e.g. C-Arm), (200 ml) | 8126430 |
| Only if needed Grease fitting | 6221837 |

For Universal Collimator:

- | | |
|--|----------|
| ▪ Spare parts kits, medical white (24-month maintenance inter-
val) | 11192199 |
|--|----------|

Paints to touch up chips/scratches in the paint finish:

- | | |
|--------------------------------|---------|
| ▪ White (spray can) | 8427734 |
| ▪ White textured (paint stick) | 3444403 |

- Medical Blue (spray can)¹ 5507046
- Medical Blue (paint stick)² 5507087

-
1. Color: light blue
 2. Color: light blue

5.1.4 Work Time/Maintenance Interval

Component	Required Work Time/Maintenance Interval
Ceiling Stand (2nd Plane)	5 hours / 12 months
DCS	1.5 hrs. / 12 months
Collimator	10 minutes / 24 months
Total Work Time, Partial Maintenance 4:	6.5 hrs/12 months, 6.16 hrs/24 months

5.2 Ceiling Stand (2nd Plane)

5.2.1 Safety - Ceiling Rails, Indirect Check of Ceiling Substructure

SIM Ceiling rails, mounting

Fig. 52:

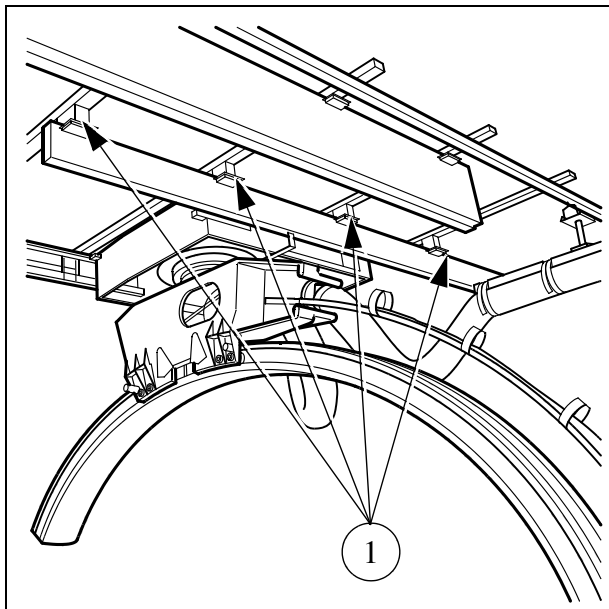

1. Remove all cover panels from the overhead carriage.
2. Check all M10 mounting screws (→ 1/ Fig. 52 Page 106) with the torque wrench. Place the torque wrench extension bar parallel to the guide rail and check for any migration or instability of the guide rails when checking the torques.
 - a) Torque: **50 Nm**
3. Move the ceiling carriage across the entire longitudinal travel range.
 - » There should be no lateral movement/distortion visible in the ceiling rails.



SIM Check the roller overhang

1. Check the roller overhang (→ 1/ Fig. 53 Page 107) on both sides along the entire travel range.
 - » The roller may protrude a maximum of 3 mm over the longitudinal rail.

Fig. 53: Roller overhang

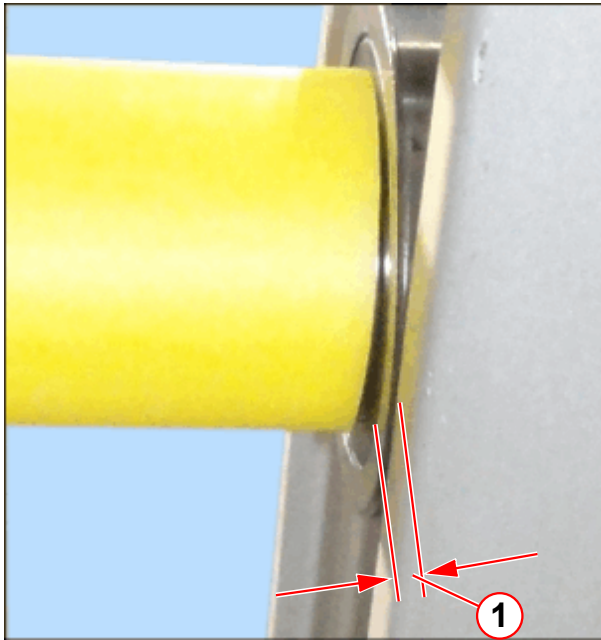

(1) Roller overhang

2. Enter the measurement of the roller overhang.

SIM Measure the longitudinal guide rail distance (only if roller overhang > 3 mm)

If the roller overhang exceeds 3 mm, the distance of the longitudinal guide rail must be checked.

1. Measure the longitudinal guide rail distance (→ 1/Fig. 54 Page 107) at both ends and in the center (→ 1+2+3/Fig. 55 Page 108).

Fig. 54: Longitudinal guide rail distance

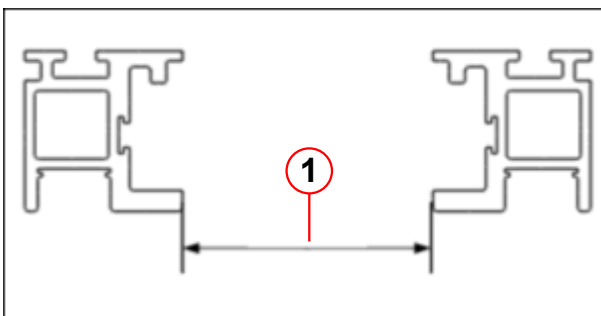

(1) Distance

Fig. 55: Longitudinal guide rails, measure distance

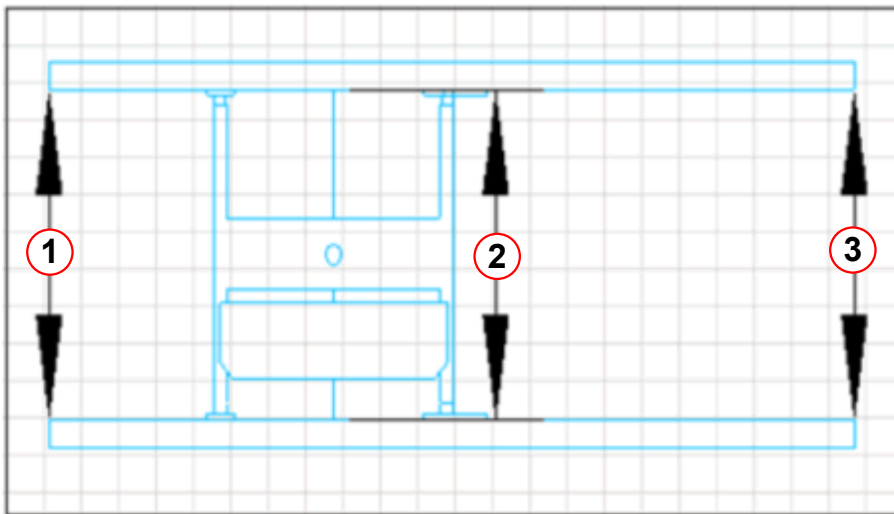

- (1) Head end
 (2) Center of longitudinal carriage
 (3) Foot end

Tab. 4 Specified distance of longitudinal guide rail for 2nd plane / Artis T:

	Overhead Carriage	Rail distance on installation	Max. permissible value ¹
<input type="checkbox"/>	Biplane, 2nd plane	Distance 940 ± 1 mm	946 mm

1. If this value is exceeded, the system may no longer be operated.

1. Enter maximum measured distance
1. If the maximum permissible value is exceeded, the ceiling substructure may no longer be sufficiently stable.
2. Do the following:
 - a) Notify the customer that the longitudinal guide rail distance is out of tolerance.
 - b) Start the escalation process.
 - c) Shut down the system until the cause is determined.

NOTICE

The system may no longer be safe to operate.

If the maximum permissible values are exceeded, proceed as follows:

- » **Determine the cause of the deviation.**
- » **The ceiling rail substructure must be inspected after consultation with the customer.**
- » **If maintenance is performed by OEM partners, notify Siemens Healthcare.**

SIM Magnetic switch, installation

Fig. 56: Sensor plate

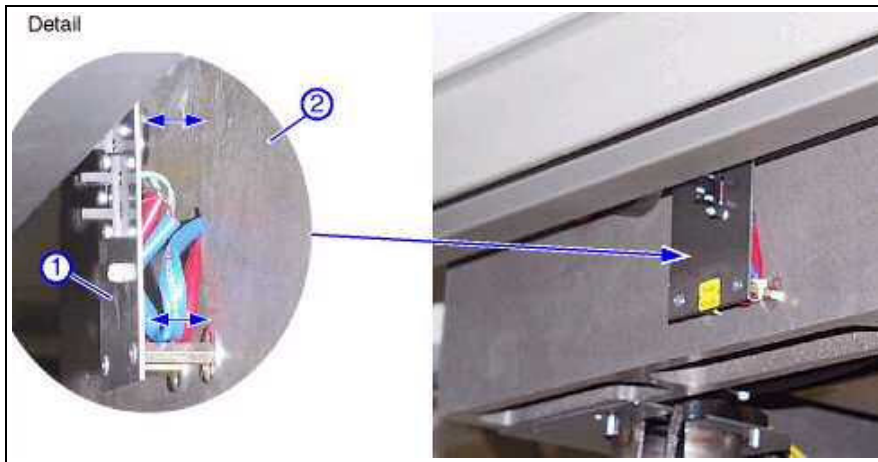

1. Check installation of the sensor plate (→ 1/ Fig. 56 Page 109).

SIM Rubber Bumpers, Installation/Condition

1. Check the rubber bumpers for damage and for correct installation.

5.2.2 Ceiling Rail Maintenance**PMP** Ceiling Rails

Fig. 57: Ceiling rails, maintenance

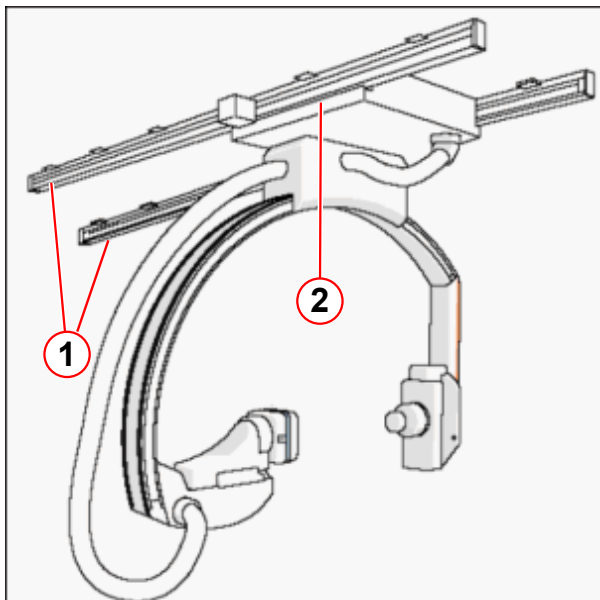

System part	Clean	Lubricate
Ceiling rails (→ 1/Fig. 57 Page 109)	Wipe dry with a lint-free cloth	n.a.
Contact surfaces of the ceiling rails (→ 1/Fig. 57 Page 109)	Wipe dry with a lint-free cloth	Viscogen KL300
Contact surfaces of the lateral guide roller bearings (→ 2/Fig. 57 Page 109)	Wipe dry with a lint-free cloth	Viscogen KL 300



When lubricating the contact surfaces of the ceiling rails, proceed as follows:

- Clean the contact surfaces of the longitudinal rail and the lateral guide roller bearings.
- Thinly apply lubricant in the area where there is bearing contact.
- Move the overhead carriage approx. 3-4 times over the complete movement range so that the lubricant is distributed evenly over the contact surfaces.
- Remove excess lubricant.
- After approx. 1 hour, again ensure that no excess lubricant is present.

5.2.2.1 Mechanical Safety, Overhead Carriage

SIM Roller bearings, installation

Fig. 58: Roller Bearings

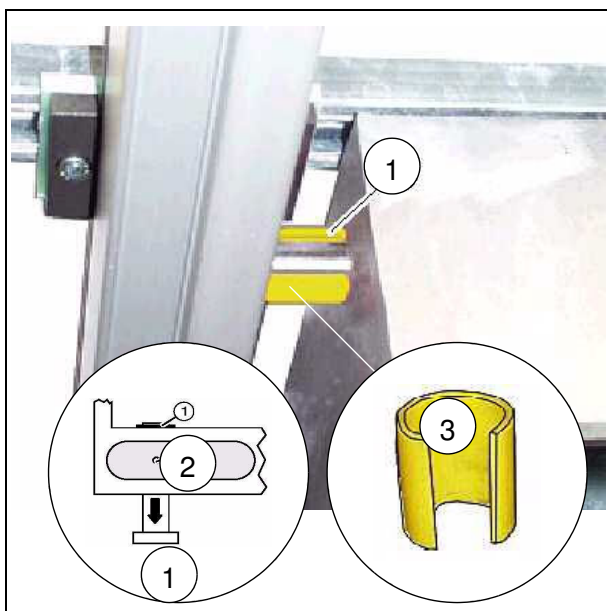

1. Check installation of the roller bearings (→ 1/Fig. 58 Page 110) (4 mm Allen screw (→ 2/Fig. 58 Page 110) and a safety sleeve (→ 3/Fig. 58 Page 110)).

SIM Lateral guide bearings, installation

Fig. 59: Lateral guide roller bearings

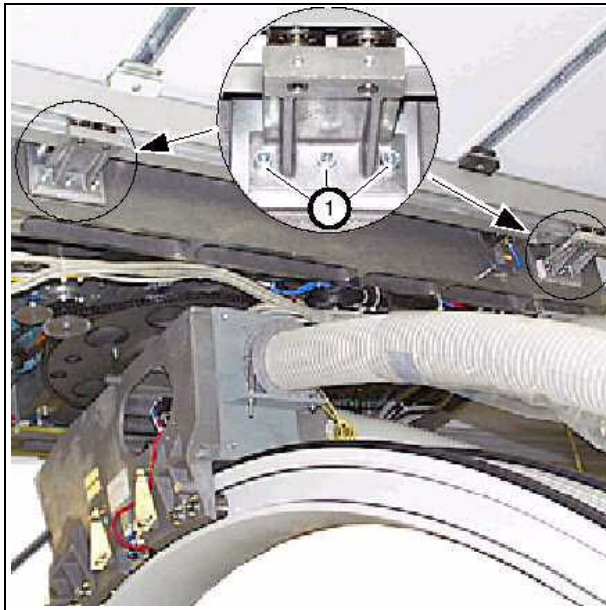

1. Check installation of the lateral guide bearings (3 Allen screws (→ 1/ Fig. 59 Page 111)).

SIM Motor longitudinal drive, installation

Fig. 60: Motor longitudinal

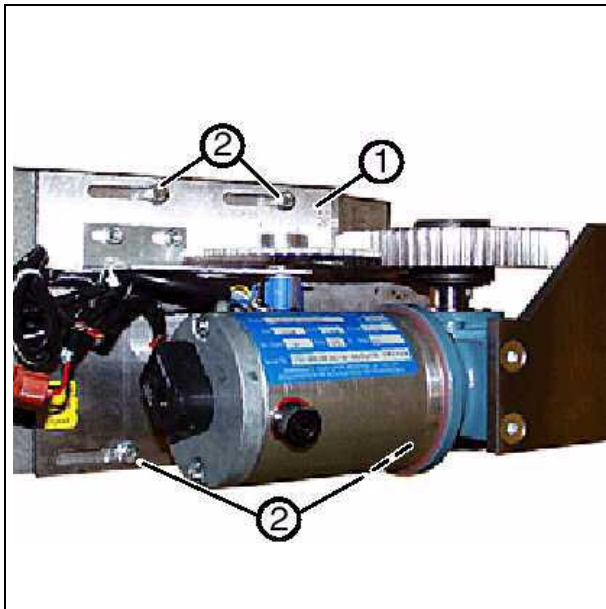

1. Check the motor mounting screws (→ 2/ Fig. 60 Page 111) (4xM4).

PMP Position potentiometers, installation

Fig. 61: Potentiometer, longitudinal

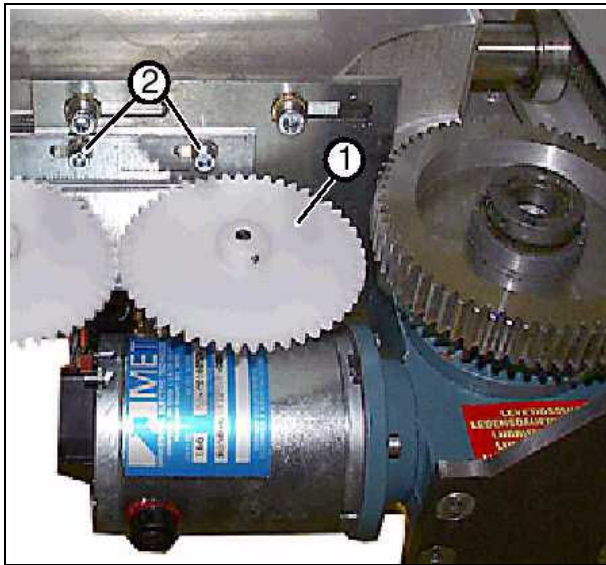

1. Check the mounting screws of the position potentiometers (→ 2/ Fig. 61 Page 112) for tightness.

5.2.2.2 Mechanical Safety, Rotation Movement**PMP** Chains and sprockets, condition

Fig. 62:

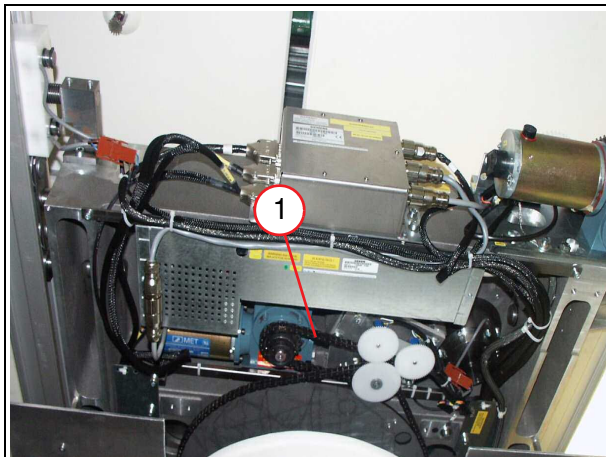

1. Check the chains and sprockets (→ 1/ Fig. 62 Page 112) for damage.

SIM Motor, installation

Fig. 63:

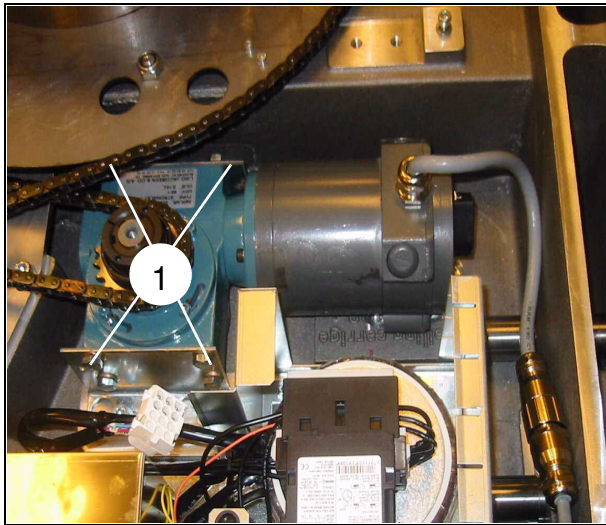

1. Gantry Rot. (→ 1/Fig. 63 Page 113) screws Check motor for secure installation.
 - a) Torque value: **25 Nm**

SIM Rotation movement stop, installation

Fig. 64: Rotation stop

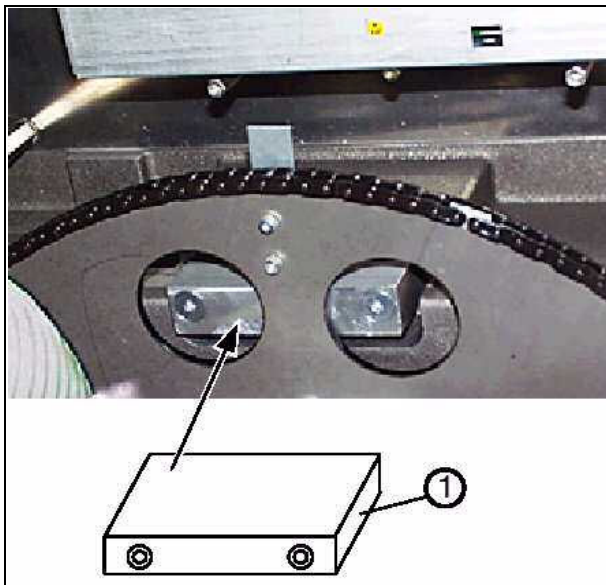

1. Check the screws (→ 1/Fig. 64 Page 113) for tightness.

5.2.2.3 Overhead Carriage Maintenance

PMP Overhead carriage

System part	Clean	Lubricate
Overhead carriage: Roller bearings and lateral guide bearings	clean with a lint-free cloth and alcohol	
Chains and sprockets		LONGTIME PD2



Only lightly lubricate chains (→ 1/ Fig. 62 Page 112).

PMP Motor unit with gear

System part	Visual check	Result
Motor unit for stand longitudinal drive	Check the motor unit for damage.	No oil may leak out at the seams between the motor and the gear.
Motor unit for rotation movement	Check the motor unit for damage.	No oil may leak out at the seams between the motor and the gear.

5.2.2.4 Mechanical Safety, C-Arm

PMP C-Arm motor, installation

Fig. 65:

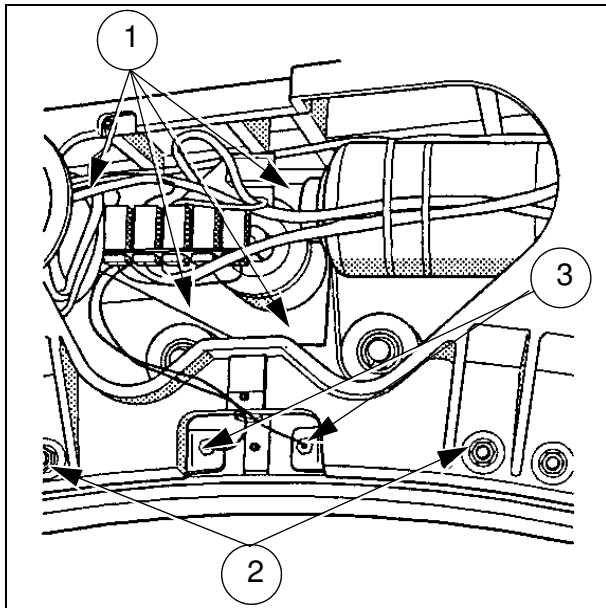

1. Check installation of the C-Arm motor (4 screws, (→ 1/ Fig. 65 Page 115)) for tightness.

PMP C-Arm bearings, installation

1. Check the C-Arm bearings for secure installation on both sides of the C-Arm (→ 2/ Fig. 65 Page 115).

PMP C-Arm guide wires, condition/damage

Fig. 66:

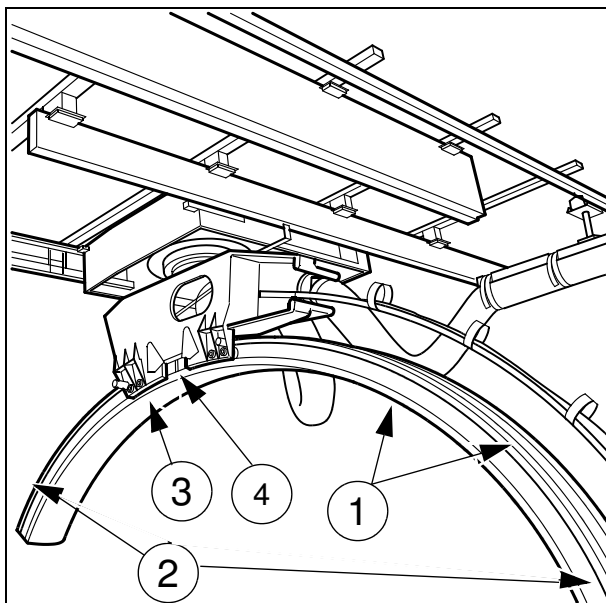

1. Perform a visual check of the guide wires (→ 1/ Fig. 66 Page 115) on both sides of the C-Arm for damage.

PMP Toothed belts, damage

Fig. 67:

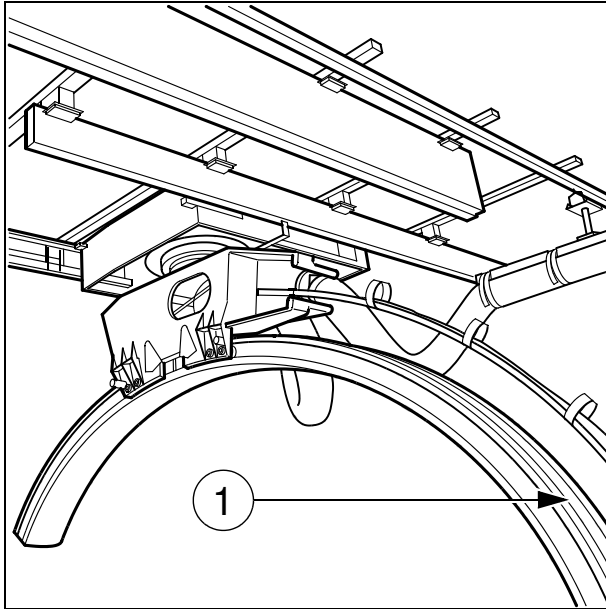

1. Check the two toothed belts (→ 1/ Fig. 67 Page 116) for damage.

PMP Toothed belts, tension

1. Move the toothed belts to the side with slight pressure.
 - a) Lateral offset should not exceed 3 mm.

5.2.3 C-Arm Maintenance

5.2.3.1 Lubricating and Cleaning the C-Arm

PMP Lubricating and cleaning the C-Arm

Fig. 68:

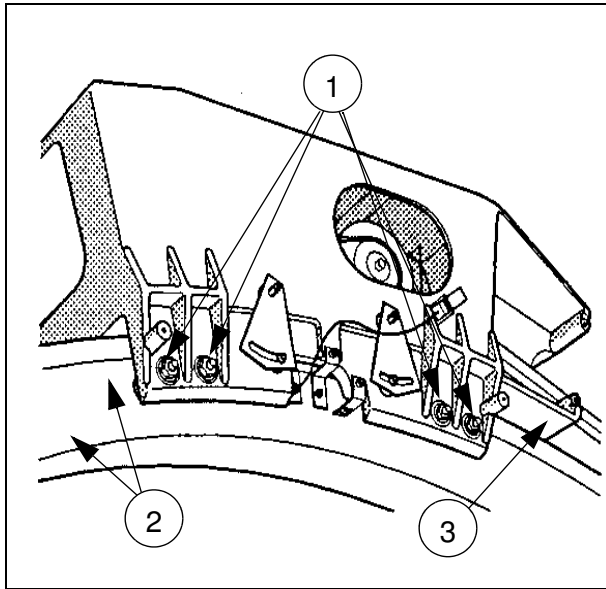

System part	Clean	Lubricate
C-Arm: Ball bearing contact surfaces (→ 1/Fig. 68 Page 117) Guide wires (→ 2/Fig. 68 Page 117) Guide wire grease fitting (→ 3/Fig. 68 Page 117)	Wipe dry with a lint-free cloth	Tonna S68 ¹ .

1. Only if necessary: Replace the grease fitting/s

5.2.3.2 Lubricating and Cleaning the Receptor

PMP Cleaning and Lubricating the Receptor

Fig. 69: Ceiling stand receptor

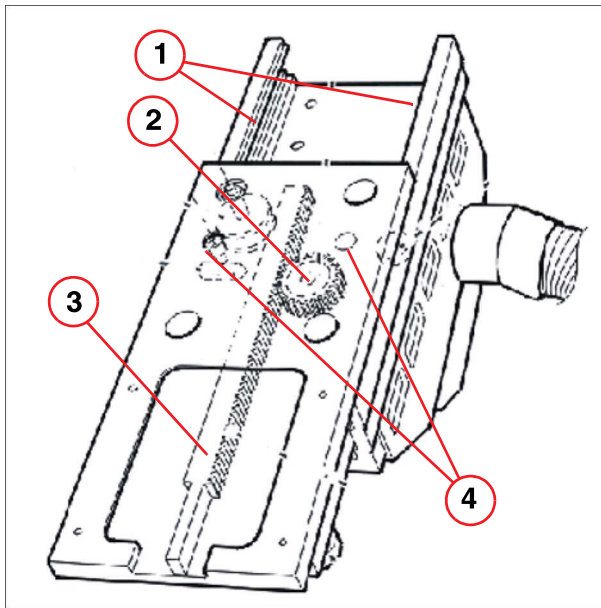

System part	Cleaning	Lubricants
Receptor: Contact rails (→ 1/Fig. 69 Page 118) Drive sprocket (→ 2/Fig. 69 Page 118) Drive rail (→ 3/Fig. 69 Page 118) Contact rail lubrication locations ¹ (→ 4/Fig. 69 Page 118)	Wipe dry with a lint-free cloth.	Tonna S68

1. Remove the plastic caps and Allen screws under them and drip approx. 5 to 10 drops of Tonna S68 oil through the holes. Then reinsert the Allen screws and caps and move the receptor several times fully to the ends in both directions. Oil may only wet the rails. Excess oil may not drip and, if necessary, must be removed.

5.2.3.3 Mechanical Safety, Tube Unit Support Arm

PMP Tube unit support arm, installation

Fig. 70:

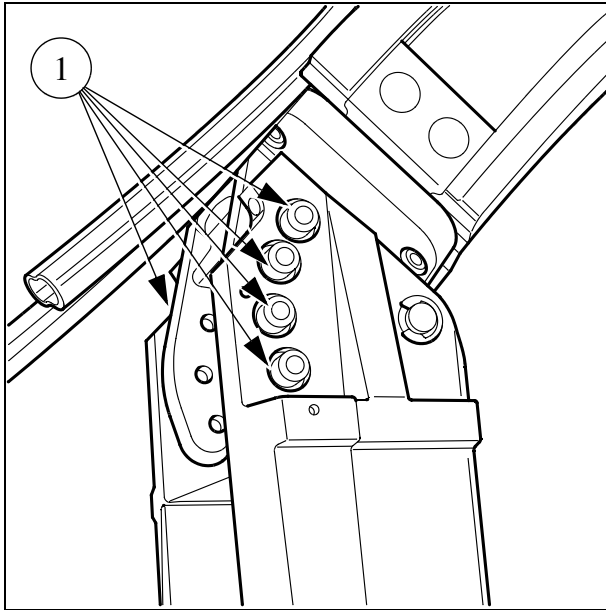

1. Check the 8 mounting screws (→ 1/ Fig. 70 Page 119) for the tube unit support arm for tightness.

5.2.3.4 Electrical Safety, Safety Devices

SIE Ceiling stand, checking the end position



If possible, perform these maintenance points at the same time as the checks listed under "Limit Switch Functions", because an enormous number of manipulations is necessary to reach the required extreme positions.

1. Move the unit into the appropriate end position.
2. The movement must stop at the software end stop.
3. The safety limit switches (UL switches) may not be activated.
4. All positions should be checked as follows:
 - a) Select **<Test Tools> <Stand & Table Tests> <Digital Input Second Plane>** in the service interface.

b) Bit 4 or 5 must switch from "0" to "1" in the corresponding end position.

Fig. 71:

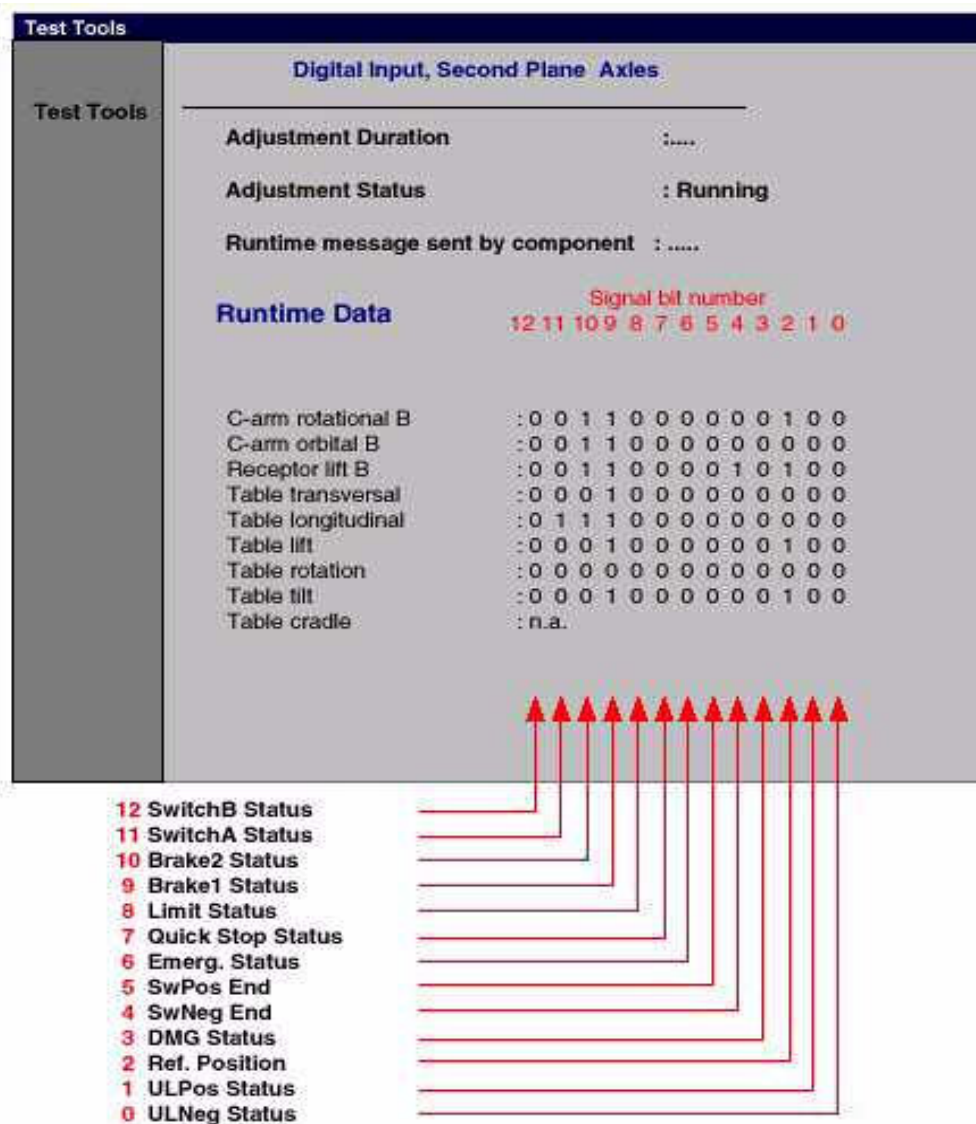

5.2.3.5 DMG Function

SIE Dead man's switch, function

1. Select <Test Tools> <Stand & Table Tests> <DMG and Quick Stop Check> in the service interface.
2. Deflect the joystick for any unit movement of the ceiling stand without pressing it axially:
 - » No unit movement is possible.
3. Deflect the joystick axially and laterally:
 - » The movement is performed.

- The DMG status of the corresponding unit movement must switch from OFF" to "ON" and the counter must increase one digit.

Fig. 72: DMG and Quick Stop Check

Test Tools			
Test Tools	DMG and Quickstop Check		
	Adjustment Duration	:	
	Adjustment Status	: Running	
	Runtime message sent by component	:	
	Runtime Data		
		Status	Counter
	DMG ULI 1	: Off	0
	DMG ULI 2	: Off	0
	DMG ULI 3	: Off	0
	DMG MCD	: Off	0
	EMGY ULI 1	: Off	0
	EMGY ULI 2	: Off	0
	EMGY ULI 3	: Off	0
EMGY MCD	: Off	0	
Quickstop ULI	: Off	0	
Quickstop MCD	: Off	0	
Quickstop Aux	: Off	0	
Quickstop MTS	: Off	0	

5.2.3.6 Limit Switch Functions

SIE Limit Switches, Function

- Select <Test Tools> <Stand and Table Tests> <End Limit Switch Check, Second Plane> in the service interface.
- After reaching the software end position, continue the particular unit movement using the override function (Prog_1 + Prog_2) until the limit switch is reached.

3. The status of the corresponding unit movement must switch from "ON" to "OFF" and the counter must increase one digit.

Fig. 73: Limit Switch Check, Second Plane

Test Tools																																	
Test Tools	End Limit Switch Check, Second Plane																																
	<p>Adjustment Duration :....</p> <p>Adjustment Status : Running</p> <p>Runtime message sent by component :</p> <p>Runtime Data</p> <table> <thead> <tr> <th>End Limit switch</th> <th>: Low end</th> <th>High end</th> </tr> </thead> <tbody> <tr> <td>C-arm rotational B</td> <td>↑ --- 0 ---</td> <td>0</td> </tr> <tr> <td>C-arm orbital B</td> <td>: --- 0 ---</td> <td>0</td> </tr> <tr> <td>Gantry Long B</td> <td>: --- 0 ---</td> <td>0</td> </tr> <tr> <td>Receptor lift B</td> <td>: --- 0 ---</td> <td>0</td> </tr> <tr> <td>Table transversal</td> <td>: --- 0 ---</td> <td>0</td> </tr> <tr> <td>Table longitudinal</td> <td>: --- 0 ---</td> <td>0</td> </tr> <tr> <td>Table lift</td> <td>: --- 0 ---</td> <td>0</td> </tr> <tr> <td>Table rotation</td> <td>↑ --- 0 ---</td> <td>0</td> </tr> <tr> <td>Table tilt</td> <td>: --- 0 ---</td> <td>0</td> </tr> <tr> <td>Table cradle</td> <td>: not configured</td> <td></td> </tr> </tbody> </table>	End Limit switch	: Low end	High end	C-arm rotational B	↑ --- 0 ---	0	C-arm orbital B	: --- 0 ---	0	Gantry Long B	: --- 0 ---	0	Receptor lift B	: --- 0 ---	0	Table transversal	: --- 0 ---	0	Table longitudinal	: --- 0 ---	0	Table lift	: --- 0 ---	0	Table rotation	↑ --- 0 ---	0	Table tilt	: --- 0 ---	0	Table cradle	: not configured
End Limit switch	: Low end	High end																															
C-arm rotational B	↑ --- 0 ---	0																															
C-arm orbital B	: --- 0 ---	0																															
Gantry Long B	: --- 0 ---	0																															
Receptor lift B	: --- 0 ---	0																															
Table transversal	: --- 0 ---	0																															
Table longitudinal	: --- 0 ---	0																															
Table lift	: --- 0 ---	0																															
Table rotation	↑ --- 0 ---	0																															
Table tilt	: --- 0 ---	0																															
Table cradle	: not configured																																

5.2.3.7 Contact Safety Switches

SIE Contact safety switches, function

Fig. 74: Ceiling stand, proximity switches

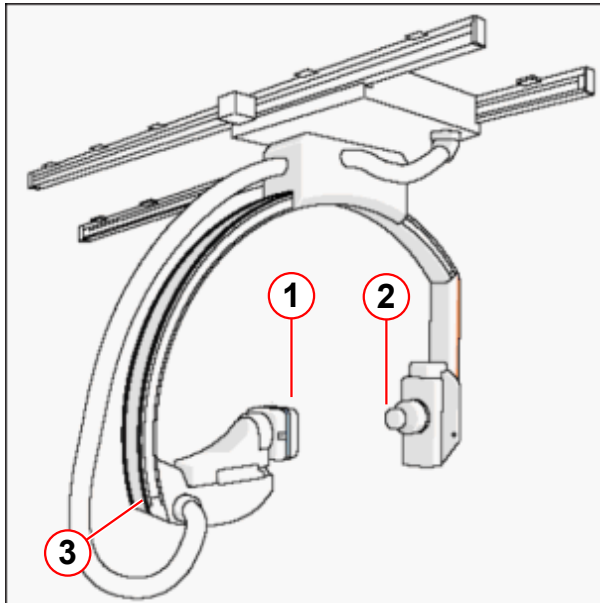

1. Select <Test Tools> <Stand and Table Tests> <Proximity Switch Check> in the Service menu.
2. Perform any unit movement.
3. Press the following contact safety switches, one after the other:
 - Detector(→ 1/Fig. 74 Page 123)
 - Collimator (→ 2/Fig. 74 Page 123)
 - Contact strips on the tube support arm (→ 3/Fig. 74 Page 123)
 - » The unit movement must stop.
 - » The message "I.I. Guard active..." must appear on the DDIS display.

5.2.3.8 Emergency Stop Switch Function

SIE Emergency stop switches, function

1. Check the emergency stop switches at the various user positions. Press the emergency stop switch at the following locations:
 - On the control consoles in the examination and control rooms.
 - At the room emergency stop switch (option).
 - » All motorized unit movements must stop immediately.
2. Perform a Caudal unit movement of the ceiling stand.
 - Press the emergency stop switch on the control console.
 - » The unit must stop immediately.

3. Perform the same check for the other axes.

5.2.4 Operating Values, Inspection

PMP Read out the error list

1. Select the event log, enter "AX_SCU" in the "source name" box and read out the service-relevant AX_SCU errors.

PMA Incremental sensor/potentiometer difference

1. Select C-Arm rotation, C-Arm orbital movement, receptor lift, park/working position over the entire range.
 - » The difference between the incremental sensor and the potentiometer value may not exceed 5 degrees; this can be checked using **<Test tools> <Stand and Table Tests> <Position Check>**. No further potentiometer or encoder errors (e.g. AX_SCU_ERR_1101) may appear in the event log. If a potentiometer or encoder-related value appears, perform a potentiometer adjustment for this axis.

PMP AD Converter, check

1. Select **<Test Tools> <Stand and Table Tests> <Position Check, Second Plane>**.
2. Select C-Arm rotation, C-Arm orbital movement, receptor lift, park/working position over the entire range:
 - » The active axis must change the potentiometer AD value and the encoder value.

PMP 0 degree setting, check

1. Move C-Arm rotation, C-Arm orbital movement into the 0 degree position.
2. Use a spirit level to check the setting.
3. If there is a difference, perform **<Tune up> <Stand> <End position Adjustment, Second Plane>**. (→ End Position Adjustment / AXA4-050.842.01)

PMP Power Supply (5V), Check

1. Select **<Test Tools> <Stand and Table Tests> <Digital Inputs, MCU Boards> and <A/D Channels, MCU Board>** and check the 5 V internal, 5 V for encoder motors 1+2 and 5 V for encoder motors 3+4.

5.2.4.1 Function Inspection

PMP Control Console, Unit Functions

1. Check the functions of the SCM (Stand Control Module), for example:
 - a) LAO and RAO

- b) Cranial and Caudal
- c) FD Lift (Receptor) UP/DOWN
- d) Base, Plane B Rotation
- e) FD Rotation and Collimator Rotation
- f) Simultaneous Movement of Planes A and B
- g) Automap
- h) Pre-Program Positions (1 or 2 attempts)
- i) Direct Positions (attempts)
- j) Factory Positions
- k) 0 Position Functions (centering movement)

5.2.5 Final Work Steps

5.2.5.1 Replacing the Green Signal Lamp

PMP Replacing the signal lamp

1. If needed, replace the green lamp on the C-Arm.



Make absolutely sure to insulate the electrical connections. Otherwise there is a risk of a short circuit (fuse will trip).

5.2.5.2 Installing the Cover Panels on the Unit

1. Reinstall all cover panels that were removed.

5.2.5.3 Clean equipment, repair any damage to painted surfaces

PMP Clean equipment, repair any damage to painted surfaces

1. Clean the unit as well as the cables and corrugated hoses.
2. If necessary, touch up chips/scratches in the paint finish.

5.2.5.4 Electrical Safety

SIE Cables and Connectors

1. Check visible cables and connectors of the monitor for damage.

5.3 Universal collimator (24 months)

5.3.1 Periodic Preventive Maintenance

5.3.1.1 Replacing the Air Filter (Universal Collimator delivered >2014)

PMP Replacing the Air Filter (Universal Collimator delivered >2014)

1. The air filter in the universal collimator must be replaced periodically - every **24 months**.



None of the cover panels on the collimator need to be removed during maintenance!

2. Loosen the screw (→ 1/Fig. 75 Page 126).

Fig. 75: Loosen the holder screw

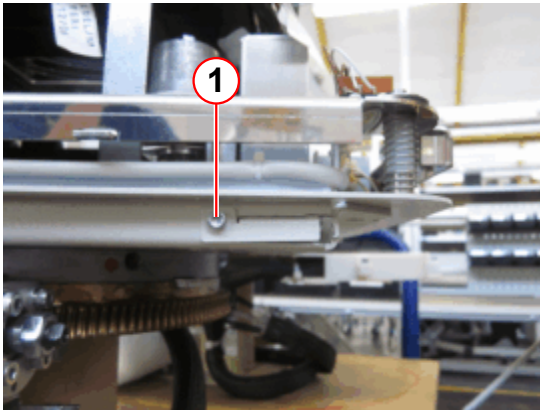

(1) Loosen the screw (ISO4762, M3x6)

3. Manually pull out the air filter insert from the holder.

Fig. 76: Pull out the air filter insert

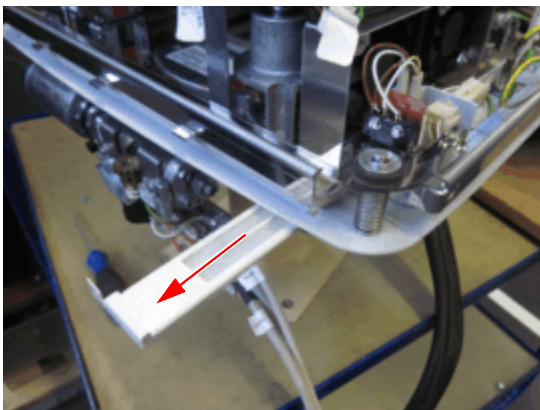

4. Replace the old air filter pad with the new air filter pad.

5. Reinsert the air filter pad into the holder.

Fig. 77: Insert in the air filter holder

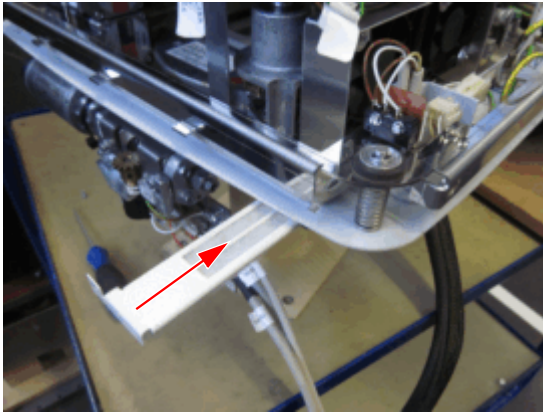

6. Retighten the screw (→ 1/ Fig. 78 Page 127).

Fig. 78: Tighten the holder screw

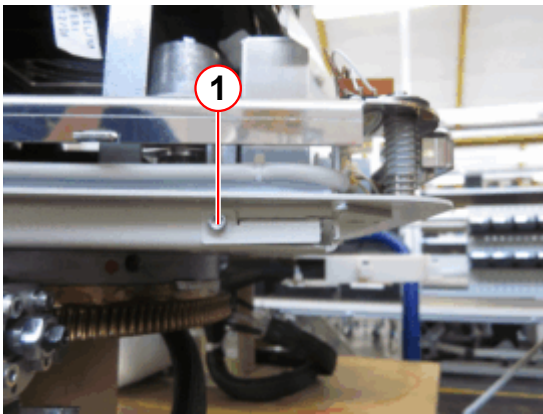

(1) Tighten the screw (ISO4762, M3x6)

5.4 DCS

5.4.1 Periodic Preventive Maintenance

PMF Weight Compensation



If a Large Display (LD) is installed on the DCS and the "Protective Screen for LD" option is used, this extra weight must be taken into consideration for the adjustment. For this, see the Retrofit Instructions for the procedure. (→ Protective shield for the Large Display / TD00-LD1.814.05).

1. Check the weight compensation. Height adjustment must be easier in the up direction than in the down direction.
 - » Required: No up or down buoyancy over the entire movement range.
2. Adjustment (only if weight compensation is not OK), see (→ Adjustment / AXA4-700.841.03)

PM Cover Panels

1. Remove the carriage cover panels.
 - a) Carefully remove the carriage cover panels and be careful not to damage the mounting clips.
 - Remove the paneling screws.
 - Lower the cover panel several centimeters on the longitudinal rail.
 - Pull the cover panel in the direction of the longitudinal rail and remove it.
2. Remove the support arm cover panels.

PM Ceiling Rails

1. Clean the contact surfaces of the ceiling rails.
2. Check for damage and for missing parts.

PMF Support arm

1. Check the ability to rotation the support arm on the carriage.
 - » Required: Easy movement from stop to stop.

PMF Display rotation

1. Check display rotation.
 - » Required: Easy

PMF Cables

1. Check the cable routing in the telescoping section of the support arm.
 - » The cable bundle may be secured with only a cable tie in the area of the Cardan joint. The cable bundle must still be freely movable.
2. Check how the cables are laid on the support arm, check for damage at both ends.
3. Check the zipper hoses for damage.

PMF Brakes**DCS**

1. Press the button for longitudinal movement.
 - » Longitudinal movement is free, rotation movement is locked. DCS can be positioned longitudinally.
2. Press the button for rotation.
 - » Rotation movement is free, longitudinal carriage is locked. DCS can be rotated.
3. Only if not OK: Check the brake pads for wear.

Extended DCS

1. Press the button for longitudinal movement.
 - » Longitudinal movement is blocked, rotation movement is possible.
2. Press the button for rotation axis 1.
 - » Rotation movement 1 is blocked, longitudinal movement and rotation movement 2 are possible.
3. Press the button for rotation axis 2.
 - » Rotation movement 2 is blocked, longitudinal movement and rotation movement 1 are possible.
4. Only if not OK: Check the brake pads for wear.

PMF Carriage

1. Check the ability to move the carriage in the longitudinal direction.
 - » Required: Smooth and even

2. Visibly mount the spring balance as in (→ 2/ Fig. 79 Page 130) and pull the longitudinal carriage in the pulling direction (→ 3/ Fig. 79 Page 130).

Fig. 79: Friction force in the longitudinal direction

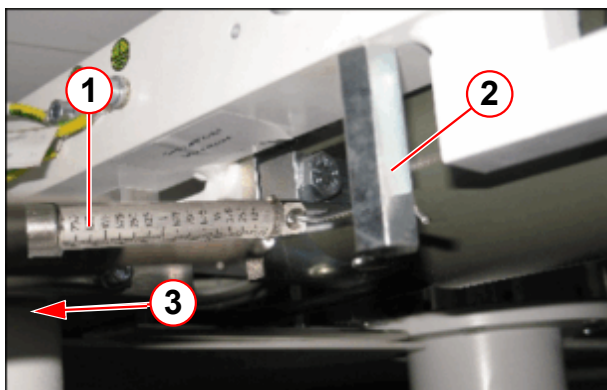

- (1) Spring balance
(2) Stud
(3) Direction of pull

3. Check the max. friction force per the following table:

Tab. 5 Longitudinal Movement, max. Contact Force

Designation	Material No.	Check from serial no.	Contact Force in the Longitudinal Movement
DCS 2	7556710	1526	10 N + 10 / - 0 N
DCS 3	7556728	2451	
DCS, -4m	7559490	1248	
DCS 2, DVI	10094044	1053	
DCS 3, DVI	10094045	1127	
DCS, 4 m, DVI	10094046	1113	
DCS 2 pro	10280859	1008	
DCS 3 pro	10280860	1009	



Beginning with the particular Serial No. (→ Tab. 5 Page 130), there is an additional adjustment possibility.

With DCS versions with the flexible plastic chain, no friction brake is configured.



There are two versions: (→ Fig. 80 Page 131) or (→ Fig. 81 Page 131). These are distinguished only by the washers and the self-locking nut. The function is the same.

4. Only if not OK: Adjust the friction force using the brake pads, see (→ Fig. 80 Page 131) or (→ Fig. 81 Page 131)

Fig. 80: Contact brake

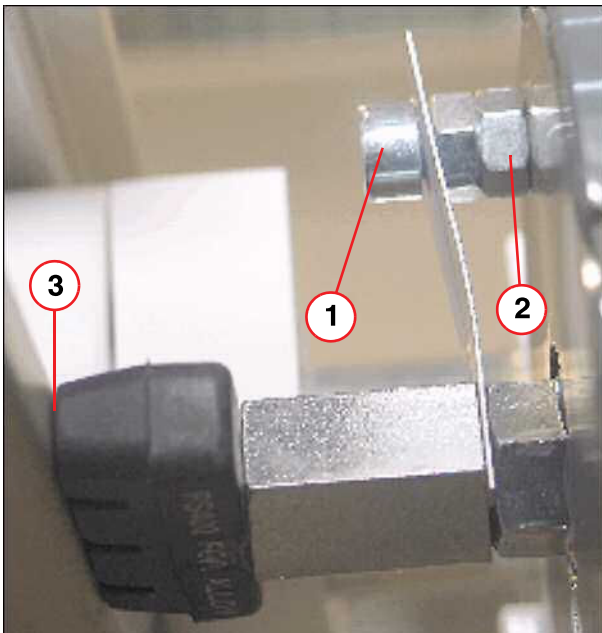

- (1) Screw
- (2) Counter nut
- (3) The brake should have slight contact.

Fig. 81: Friction brake installed (longitudinal)

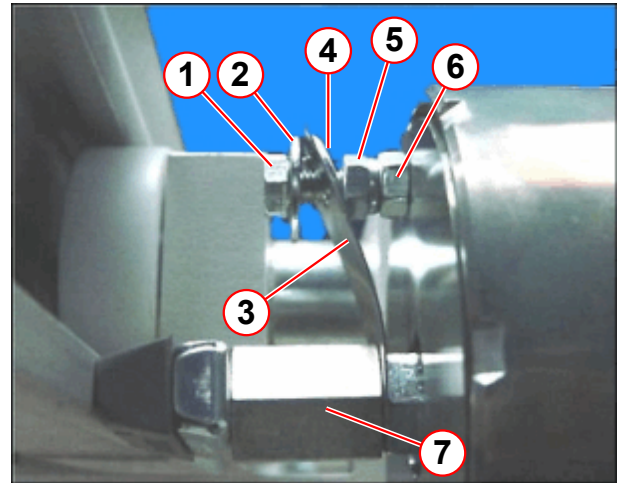

- (1) Hex screw
- (2) Washer
- (3) Plate washer
- (4) Washer
- (5) Self-locking nut
- (6) Nut
- (7) Magnet axis

5.4.2 Mechanical Safety

5.4.2.1 Stops, Roller Bearings

SIM Stops

1. Check the condition of the stops and for secure installation.
 - In the ceiling rails for the longitudinal carriage
 - System rotation on the support arm
 - Monitor rotation
 - Vertical adjustment

» Required: No damage; if necessary, replace.

SIM Bearings

1. Check installation of the roller bearings.
2. Check the condition of all roller bearings.
 - » Required: No damage on the contact surface.

3. Check the roller bearings.

- » Required: The full width of the roller bearings must be in contact with the surface on the guide strip of the profile (→ 1/ Fig. 82 Page 132).

Fig. 82:

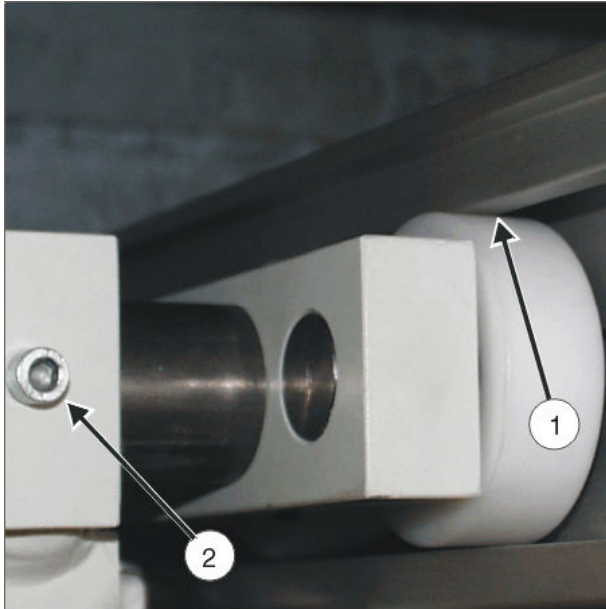

5.4.2.2 Ceiling Rails, Indirect Check of Ceiling Substructure



This test item is omitted if an Extended DCS operates in the same ceiling rails as the 2nd plane of a biplane system or a ceiling system. It is performed in the "2nd Plane" / "Artis T" chapters.

SIM Ceiling rail mounting

1. Check the mounting rails on the ceiling; retighten the screws to a torque of $50 \text{ Nm} \pm 10 \%$. Place the torque wrench extension bar parallel to the guide rail and check for any migration or instability of the guide rails when checking the torques.

SIM Longitudinal Travel of Ceiling Carriage

1. Move the ceiling carriage across the entire longitudinal travel range.
 - » There should be no lateral movement/distortion visible in the ceiling rails.

SIM Check the roller overhang

1. Check the roller overhang (→ 1/ Fig. 83 Page 133) on both sides along the entire travel range.
 - » The roller may protrude a maximum of 3 mm over the longitudinal rail.

Fig. 83: DCS roller overhang

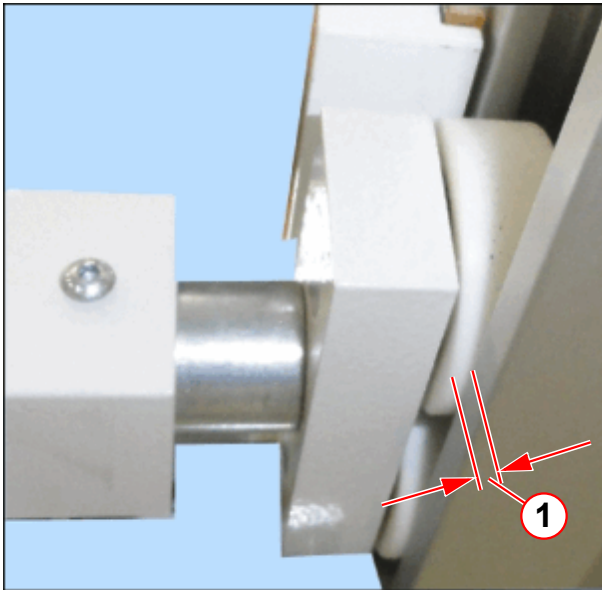

(1) Roller overhang

2. Enter the measurement of the roller overhang.

SIM Measure the longitudinal guide rail distance (only if roller overhang > 3 mm)

If the roller overhang exceeds 3 mm, the distance of the longitudinal guide rail must be checked.

1. Measure the longitudinal guide rail distance (→ 1/ Fig. 84 Page 133) at both ends and in the center (→ 1+2+3/ Fig. 85 Page 134).

Fig. 84: Longitudinal guide rail distance

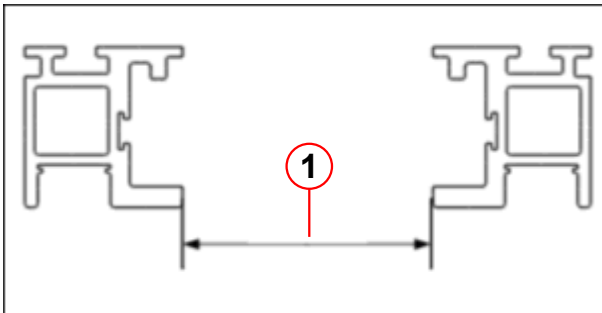

(1) Distance

Fig. 85: Longitudinal guide rails, measure distance

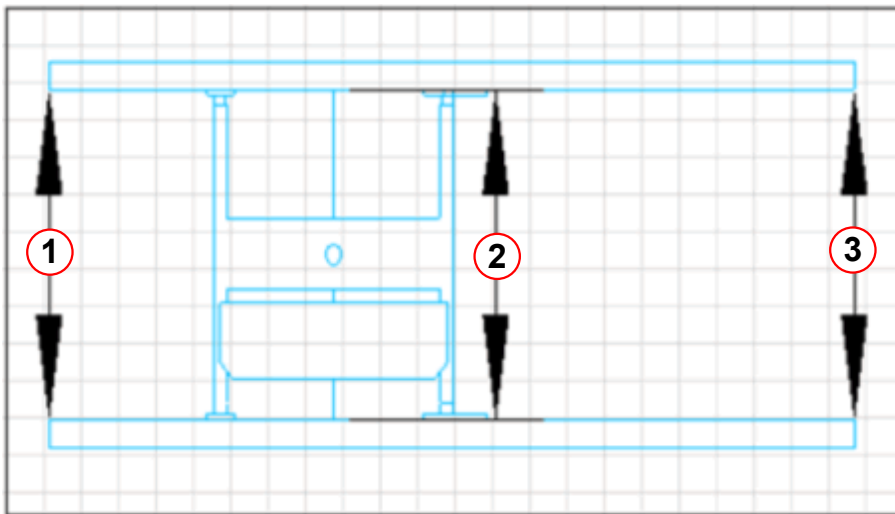

- (1) Head end
- (2) Center of longitudinal carriage
- (3) Foot end

Tab. 6 Required measurement for longitudinal guide rail distance for DCS

	Monitor Suspension	Rail distance on installation	Max. permissible value ¹
<input type="checkbox"/>	DCS, DCS pro	Distance 550 ± 1 mm	556 mm
<input type="checkbox"/>	Extended DCS	Distance 940 ± 1 mm	946 mm

1. If this value is exceeded, the system may no longer be operated.

1. Enter maximum measured distance
 1. If the maximum permissible value is exceeded, the ceiling substructure may no longer be sufficiently stable.
 2. Do the following:
 - a) Notify the customer that the longitudinal guide rail distance is out of tolerance.
 - b) Start the escalation process.
 - c) Shut down the system until the cause is determined.

NOTICE

The system may no longer be safe to operate.

If the maximum permissible values are exceeded, proceed as follows:

- » Determine the cause of the deviation.
- » The ceiling rail substructure must be inspected after consultation with the customer.
- » If maintenance is performed by OEM partners, notify Siemens Healthcare.

5.4.2.3 Monitor Arm, Display Support

SIM Articulated head

1. Check the condition of the articulated head.

- » **Required: No damage to any possible internal contact points**

Fig. 86: Cardan joint



SIM Display support

1. Check the 4 Allen screws on the display support underneath the Cardan joint for proper tightness. Two Allen screws are for attaching the data display (if present) as well.

5.4.3 Electrical Safety

SIE Longitudinal limit switch



Perform only for Extended DCS (DCS carriage for 2nd plane / Artis T is operated in the same ceiling rails).

1. Move the DCS carriage all the way to the foot end.
 - » The limit switches must be activated.
 - » At the same time, however, the carriage is pushed back out of this end position by the elastic stop. The limit switches are thus only briefly activated when "over pressing".

Fig. 87: End position switch

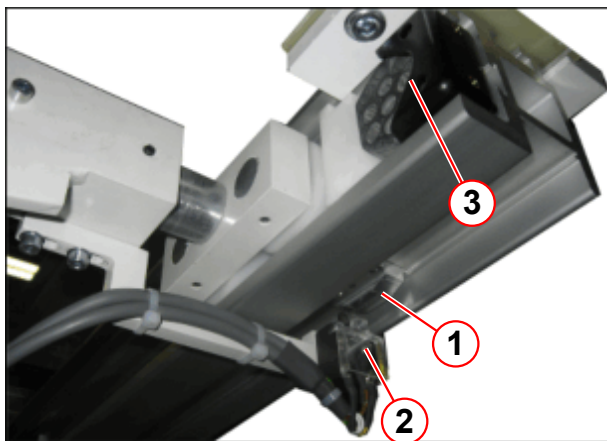

SIE Height limit switch

1. Press the support arm in the direction of the ceiling.
 - » The limit switches for the height limitation must be activated and table lift is blocked.
 - » However, at the same time the support arm is press back out of this end position by the elastic stop. The limit switches are thus only briefly activated when "over pressing".

Fig. 88: Height stop

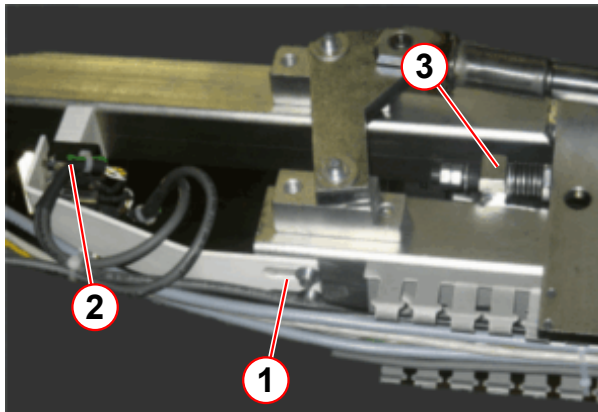

- (1) Height stop limit switch adjustment
- (2) Height stop limit switch
- (3) Height stop

SIE Cap on the support arm

1. Press on the cap (→ 1/ Fig. 89 Page 137).

- » The limit switches must be activated and, e.g., table lift is blocked.

Fig. 89: Checking the safety end switches

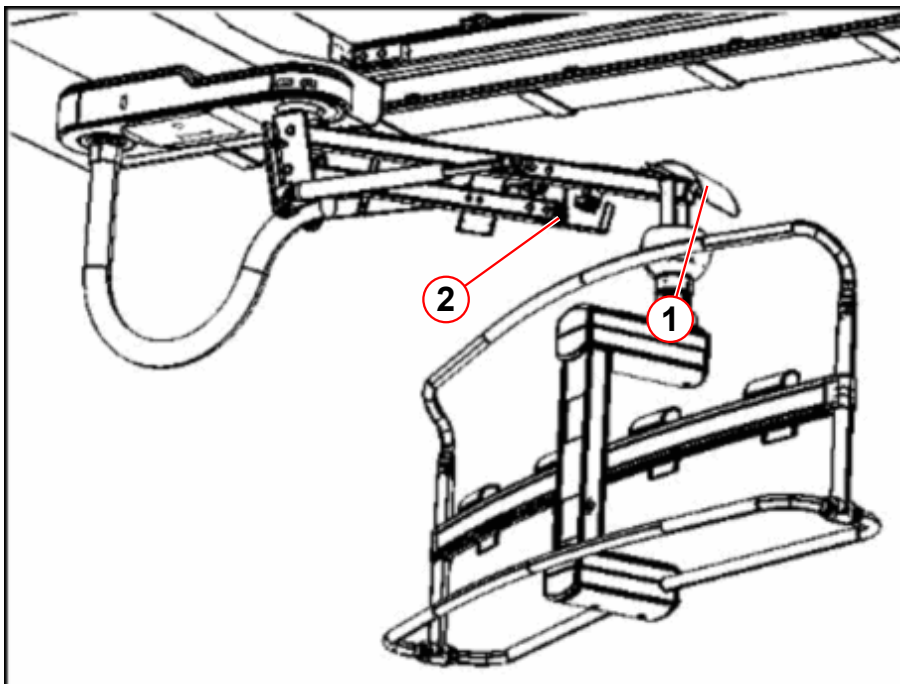

- (1) Contact safety switch
- (2) Height stop

5.4.4 Final Work Steps

PM Electrical connections

1. Check the condition of M2 plug-in connection in the carriage and to ensure it is engaged.
2. Check to ensure the cables on the monitor connection panel are in good condition and are securely plugged in.

PM Clean DCS, touch up surface damage

1. Remove dirt and deposits in the DCS.
2. With DCS versions with the flexible plastic chain, clean the additional cover panel for the flexible plastic chain.
3. Install all cover panels.
4. Clean cover panels, cables (corrugated hose).

5.5 Final Work Steps

5.5.1 Installing the Cover Panels

1. Reinstall all cover panels that were removed.

5.5.2 Electrical Safety, Ground Wire Check

5.5.2.1 General information regarding ground wire testing as per IEC 62353

General measurement procedure:

Test the ground wire resistance between all conductible parts of the system that can be touched and the ground wire bus rail (in the generator, power distributor, for example).

Fig. 90: Ground wire measurement with fixed power line connection

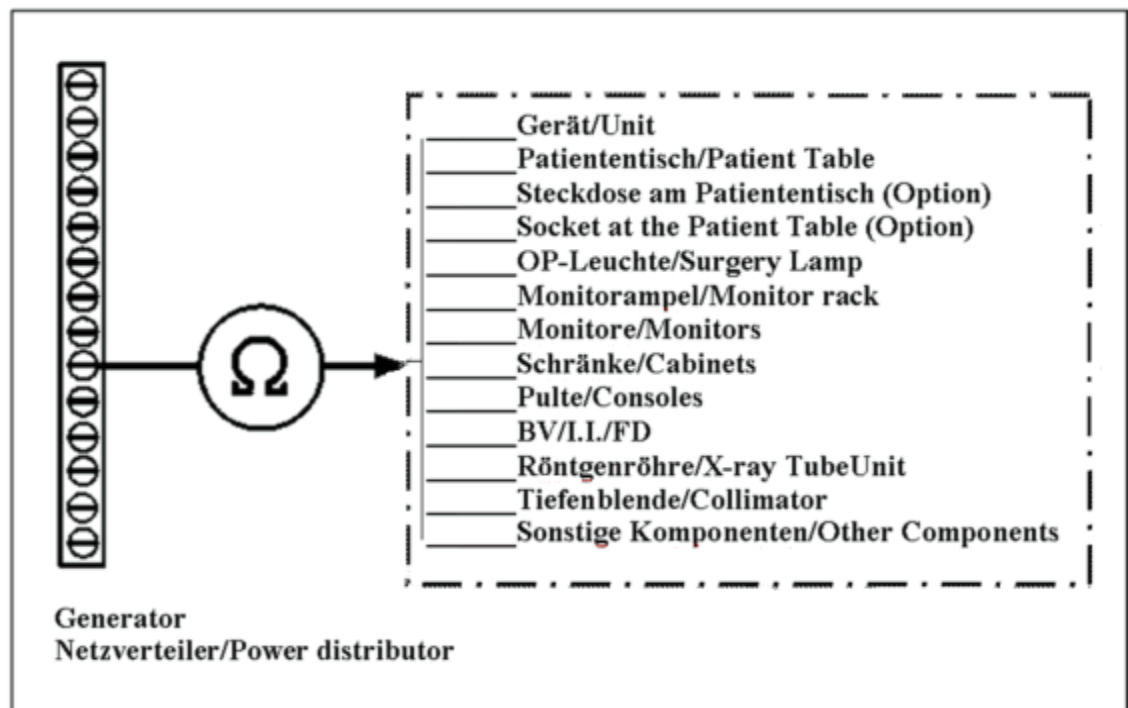

According to IEC 62353, the measured values from the old maintenance certificates as well as the startup certificate from the initial maintenance must be compared with the new measured values. If a significant difference is found or if the measured value exceeds **300 mΩ**, initiate corrective measures. Usually, the problem is that the ground wires are not connected or are incorrectly connected.

! DANGER

Risk of accident due to electric shock!

- » Correct any incorrect ground wire connections prior to turning the unit over to the customer.

5.5.2.2 Ground wire measurement for the ceiling stand (2nd plane)

1. Switch off power to the system.
2. Measure the resistance between an exposed, conducting part on the ceiling stand (2nd plane) and the ground wire bus rail in the power distributor.
3. Record the value in the maintenance certificate.



SIE Ground wire test for the ceiling stand (2nd plane) ($\leq 300 \text{ m}\Omega$)

5.5.2.3 Ground wire measurement for DCS

1. Switch off power to the system.
2. Measure the resistance between an exposed, conducting part on the DCS and the ground wire bus rail in the power distributor.
3. Record the value in the maintenance certificate.



SIE Ground wire test for the DCS ($\leq 300 \text{ m}\Omega$)

SIE Ground wire test for the DCS, optional ($\leq 300 \text{ m}\Omega$)

5.5.2.4 Ground wire measurement for the collimator

1. Switch off power to the system.
2. Measure the resistance between an exposed, conducting part on the collimator and the ground wire bus rail in the power distributor.
3. Record the value in the maintenance certificate.



SIE Ground wire test for the collimator ($\leq 300 \text{ m}\Omega$)



Mandatory:

The ground wire test according to IEC 62353 absolutely must be performed at the end of the maintenance call before the system is turned back over the customer for patient operation.

This applies regardless of whether or not all planned maintenance points for this partial maintenance have been completed.

6.1 Special Requirements

6.1.1 Required Tools, Test Equipment and Aids

- Standard toolkit 9702457
- Fluke 287 digital multimeter 9994831
- or
- Multimeter, measurement range 1 to 20 Volt DC, accuracy at least 1%. n.a.
- Protective ground wire test meter This test meter, for example the general-purpose test meter, must meet the specifications of IEC 61557/EN 61557/VDE 0413/IEC 62353.
- SECUTEST® SIII or PROFITEST® 0100S-II (→ Order directly / Page 187)
- or
- Safety Analyser Rigel 62353 230V 10848526
- Safety Analyser Rigel 62353 130V 10848527
- or
- Rigel 288 Order directly from Rigel
- or
- Fluke ESA 612 / ESA 615 Order directly from Fluke
- ESD equipment 9702606
- Antistatic vacuum cleaner with nozzle (observe country-specific regulations) n.a.
- Lint-free cleaning cloths n.a.
- Brush to apply grease n.a.
- Brush to remove dust n.a.
- PTW DIADOS 9717612
- or
- UNFORS dose measurement meter For direct purchase, see the SPC.
- TV dynamics test (for IQAP Maintenance Test) n.a.
- Luminous density meter (for IQAP Maintenance Test) n.a.

Only for InSpace 3D (option) IQAP:

- | | |
|-----------------------------------|----------|
| ■ Resolution test type 41 | 2871820 |
| ■ Calibration phantom ball spiral | 7139830 |
| ■ Holder, 3D phantom | 10590376 |

For heated patient mattress only:

- | | |
|--|-------------------------|
| ■ Heated Mattress Testset (borrowed measuring equipment) | 10849216 |
| ■ For Germany only: STK inspection seal (label) | Order from We-
bLogX |

All tools, test equipment and aids listed with a part number can be ordered from the Service Parts Catalogue (SPC).

6.1.2 Required Documents

- CB-DOC Artis zee, AXA4-000.803.02....

6.1.3 Required Materials**Patient Table:**

- | | |
|--|--------------------|
| ■ Cleaning Agents and Rust Protection for Rails
e.g. WD40 contact spray (spray can, 400 g), | 2870061 |
| ■ Longtime PD2 (20 g tube)
or Longtime PD2 (1 kg)
for bearing cages, open ball bearings, gears ... | 3491271
7395445 |
| ■ Cleaning agent for plastic, glass and painted parts
e.g. Hakapur concentrated cleaner (500 g), | 9660648 |
| ■ Alcohol | n.a. |

Paints to touch up chips/scratches in the paint finish:

- | | |
|---|---------|
| ■ White (spray can) | 8427734 |
| ■ White textured (paint stick) | 3444403 |
| ■ Medical Blue (spray can) ¹ | 5507046 |
| ■ Medical Blue (paint stick) ² | 5507087 |

1. Color: light blue

2. Color: light blue

6.1.4 Work Time/Maintenance Interval

Component	Required Work Time/Maintenance Interval
Patient Table	3,5 hrs. / 12 months
Heated patient mattress (optional)	1.5 h / 24 months
Uninterruptible Power Supply (optional)	0,5 hrs. / 12 months
Final Work Steps	1 hour / 12 months
Total Work Time, Partial Maintenance 5:	5.0 h /12 months, 6.5 h / 24 months

6.2 Patient Table

6.2.1 Affected Components

These instructions are applicable for the following patient tables:

- Patient table, basic unit, Part No. 5767004
- Patient table, basic unit with stepping movement, Part No. 5767012
- Patient table, basic unit with stepping movement + tilting, Part No. 5767020
- OR table, Part No. 5767053



The check points are applicable for all tables listed above with a few exceptions!
For the exceptions, a reference to the affected table models is provided!

6.2.2 Mechanical Safety

SIM Installation Plate, Checking the Mounting

1. Set the following:
 - Floor stand and, if applicable, ceiling stand in park position
 - Move the table all the way up
 - Table in transverse direction approx. in the middle position
 - Block table transverse direction at the table control console
 - Table not turned
 - Tabletop all the way at the head end
2. By loading the tabletop at the head end with approx. 80 kg, check for safe and secure installation of the patient table.
3. Move the tabletop all the way to the foot end and by sufficiently loading the foot end (approx. 80 kg) check for safe and secure installation of the patient table.
4. Turn the tabletop 90° to the left/right, move all the way to the head end and by sufficiently loading the head end, check in both positions for safe and secure installation of the patient table.

SIM Check of the Hydraulic Systems

The table hydraulic drives are closed systems and are maintenance-free. If there is a malfunction, the complete assembly must be replaced.

1. Move the table into the top end position.

2. Remove the cover panels in the following sequence:

Fig. 91: Removing the cover panel

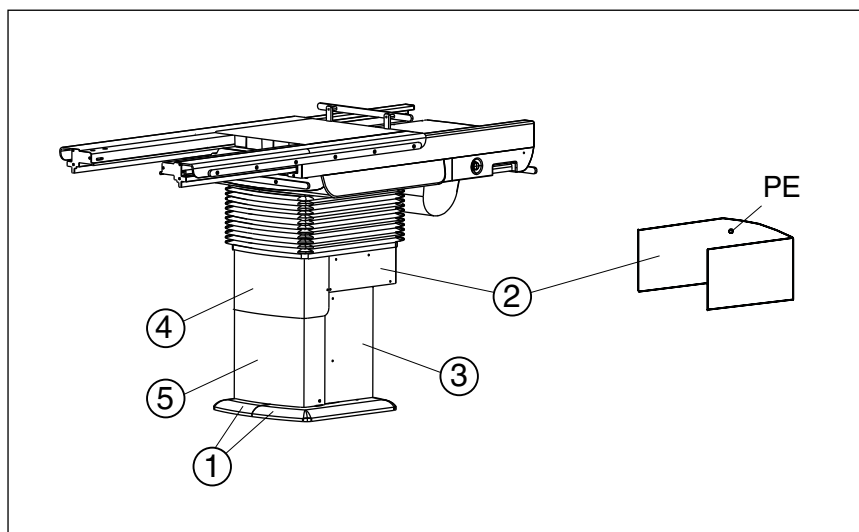

- (1), 2 parts; to make the countersunk screws accessible, move the table sideways.



The cover panels are identical, except for the markings (table rotation 0° , $+30^\circ$, -30°) (\rightarrow 1/Fig. 91 Page 146). Therefore the two cover panels may not be confused with each other when reinstalling them, e.g. appropriately label the right cover panel prior to removing it.

- (2); disconnect the ground wire
- (3); disconnect the ground wire
- (4); no ground wire connection
- (5); no ground wire connection

3. Insert the safety aids (lift safety stud and, if applicable, tilt safety brackets) (\rightarrow Patient Table / Page 13).



WARNING

When working inside the table base, serious injury can result if there is unintentional lowering of the table. With tilting tables, there is also a risk of crushing between the tilt support and the lift unit if there is unintentional tilting.

- » Install the safety aids included in the shipment (lift safety stud and, if applicable, tilt safety brackets).

4. Carry out a visual check of the hydraulic systems:

Fig. 92: Hydraulic assemblies, maximum configuration

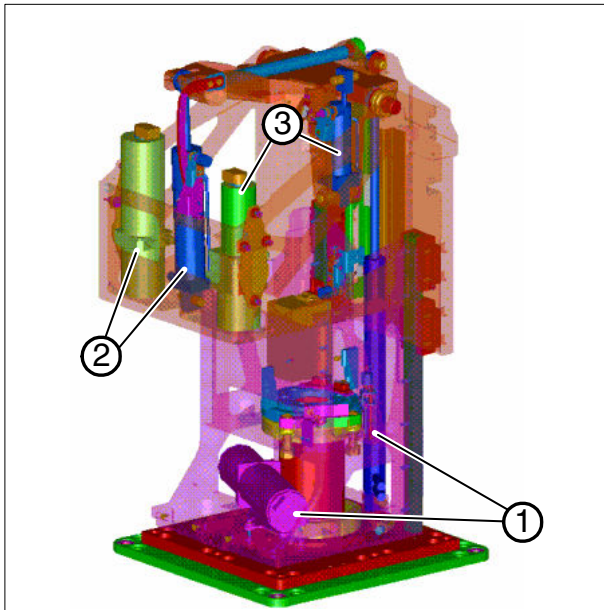

- Lift hydraulics (→ 1/Fig. 92 Page 147)
 - Tilt hydraulics (option) (→ 2/Fig. 92 Page 147)
 - Cant hydraulics (option) (→ 3/Fig. 92 Page 147)
5. Check the hydraulic hoses and connections of the hydraulic hoses to the pumps and pistons for damage (visual check).
 6. Examine the hydraulic hoses for kinks.
 7. Remove the lift safety stud and, if applicable, tilt safety brackets.

SIE Testing the S20 Table Tilt Switch (only with tilting table, Part No. 57 67 020)

NOTE: There is no S20 switch with the OR table.

1. Open the service cover. Select **Test Tools > Stand & Table Tests > End Limit Switch Check, Floor Stand** and press **Start**.
2. Move the table into the top position.

3. Press the S20 safety switch. (→ S20/Fig. 93 Page 148)

Fig. 93: S20 safety switch (lift-tilt limit)

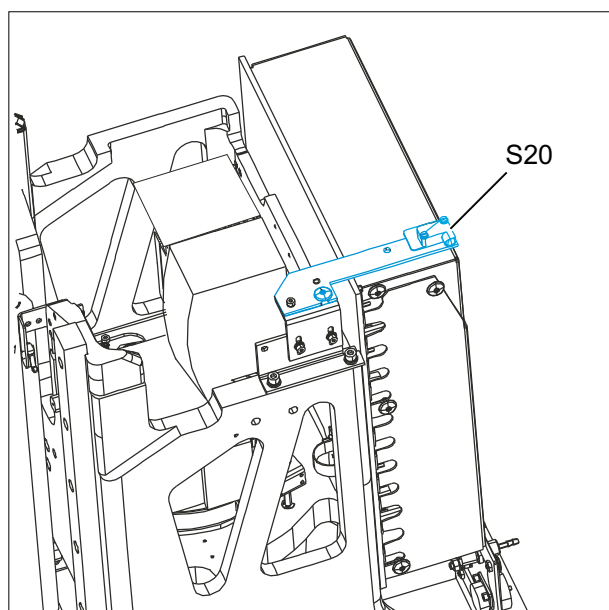

4. In the service screen for **End Limit Switch Check**, the low display for Table Lift and Table Tilt is set to OK (→ Pfeil/Fig. 94 Page 148). This means that the S20 tilt switch is activated.

Fig. 94:

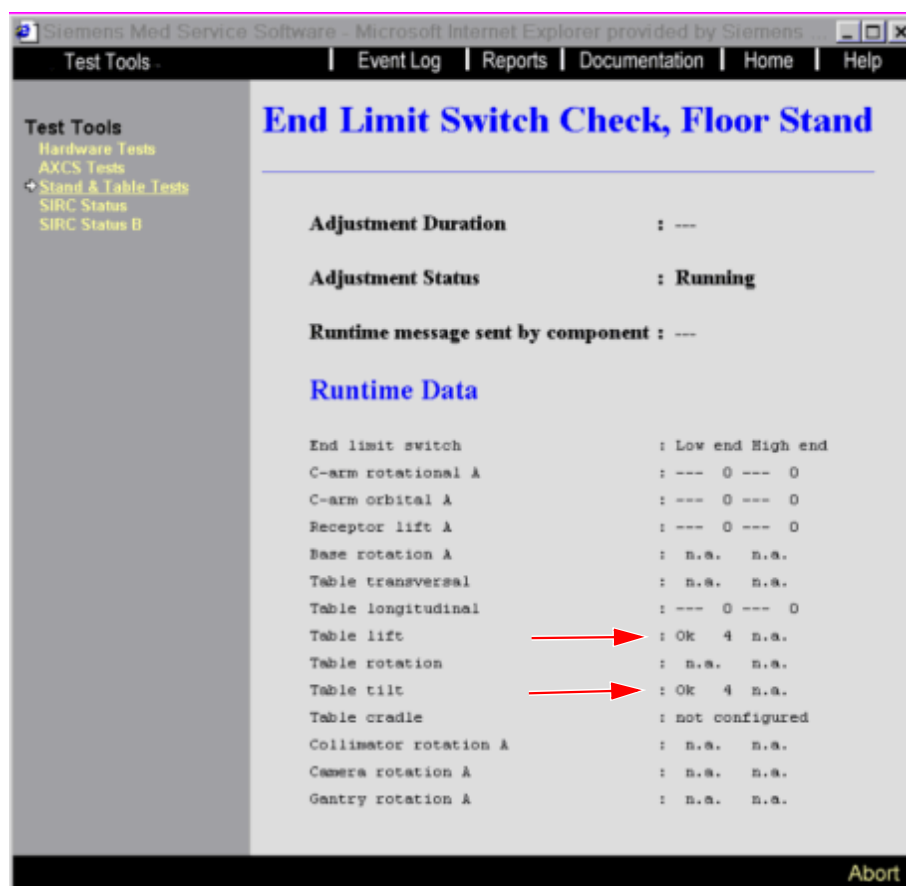

SIM Checking the Function of the Tabletop Brakes

1. Initiate a table transverse movement (→ 3/ Fig. 95 Page 149).

Fig. 95: Table control console, maximum configuration

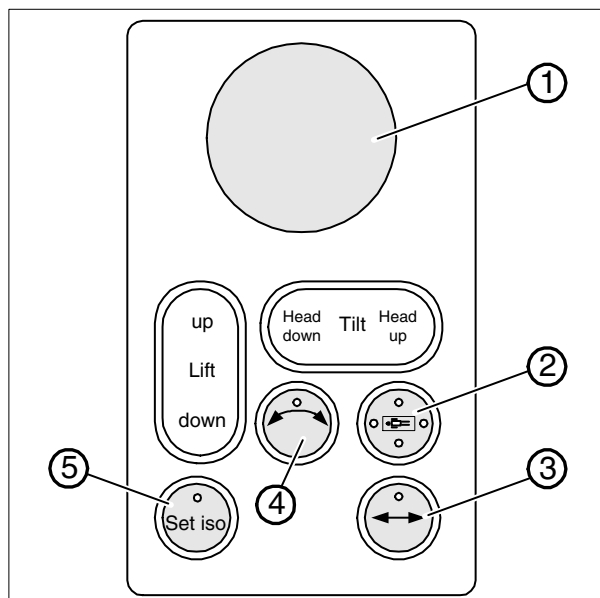

- (1) Handswitch
- (2) Orientation
- (3) Blocking for table transverse movement
- (4) Selection of lateral table tilt (option)
- (5) Isocenter selection

2. Press and hold the handswitch (→ 1/ Fig. 95 Page 149); the table must be easily movable transversely and longitudinally (approx. 20 - 25 N).
3. Release the handswitch:
 - » The tabletop must latch in position longitudinally and transversely.
4. Move the table all the way to the foot end and check rotation for play.

SIM Checking for Damage to the Tabletop(s)

1. To the extent they are present, remove the accessories such as the articulated arm rests (→ Fig. 96 Page 150), head-end mount (→ Fig. 97 Page 150), hand grips (→ Fig. 98 Page 150), infusion bottle holder (→ Fig. 99 Page 150) etc.
2. Check the tabletop(s) for damage and, if necessary, file off any sharp edges.

SIM Checking the Accessories

1. Check the accessories for damage, reinstall them and make sure they are securely in place.

Fig. 96: Articulated arm rests

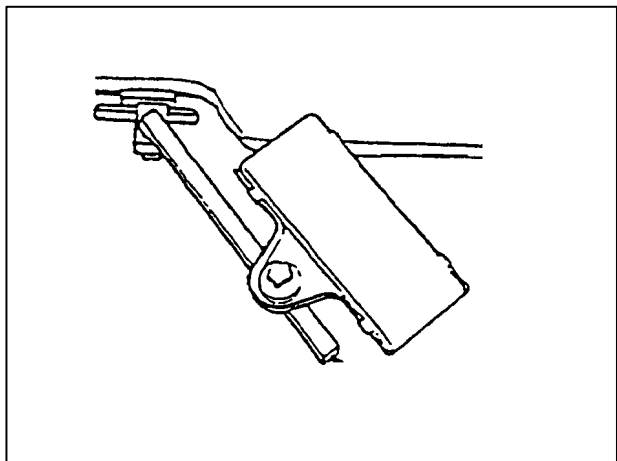

Fig. 97: Head-end mount

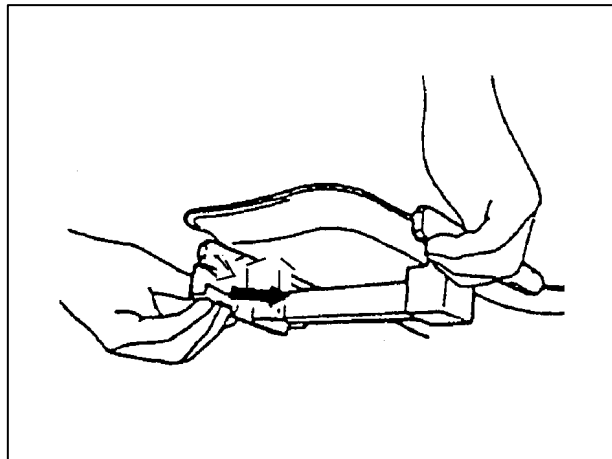

Fig. 98: Handgrips

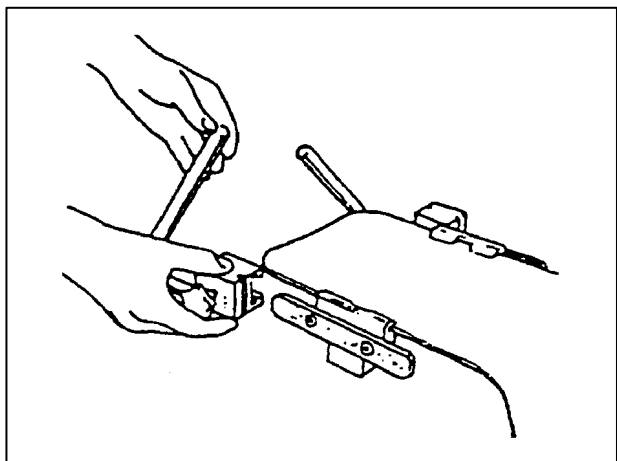
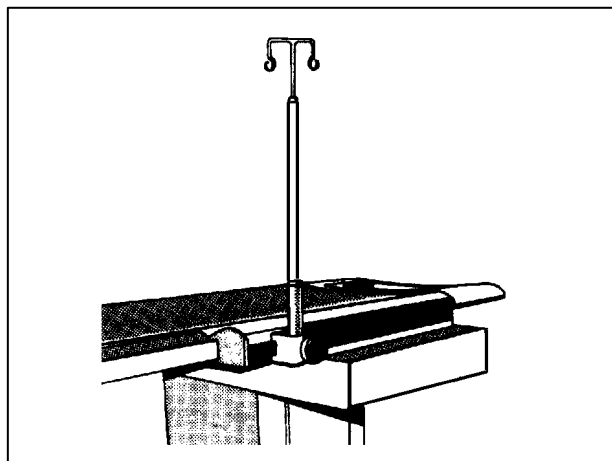

Fig. 99: Infusion bottle holder

**6.2.3 Electrical Safety****SIE** Testing EMERGENCY STOP

1. Check the emergency stop function at the various operating locations. To do this, press the emergency stop button on:
 - Examination room control modules
 - Control room emergency stop (optional)
 - » All motorized movements must be interrupted.

SIE Test the tabletop contact safety device.

Fig. 100: Test of the contact safety device

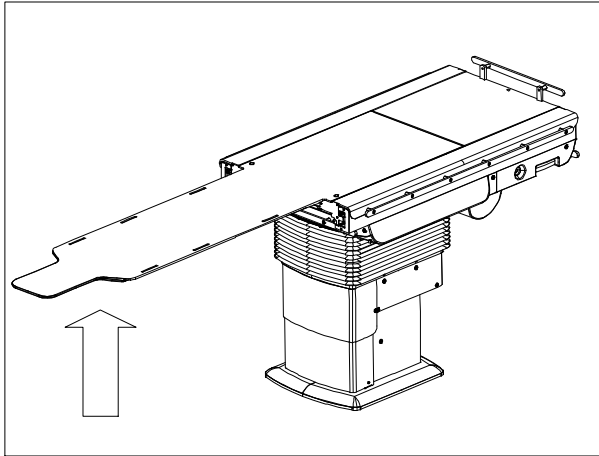

1. Move the table all the way up.
2. Move down the table and while doing so, lift it at the front (see arrow)
(→ Fig. 100 Page 151).
 - » The unit down movement must stop.
3. Check all screws for the configured tabletops for tightness.

SIE Test tabletop sensing.

Fig. 101: Tabletops that can be shipped

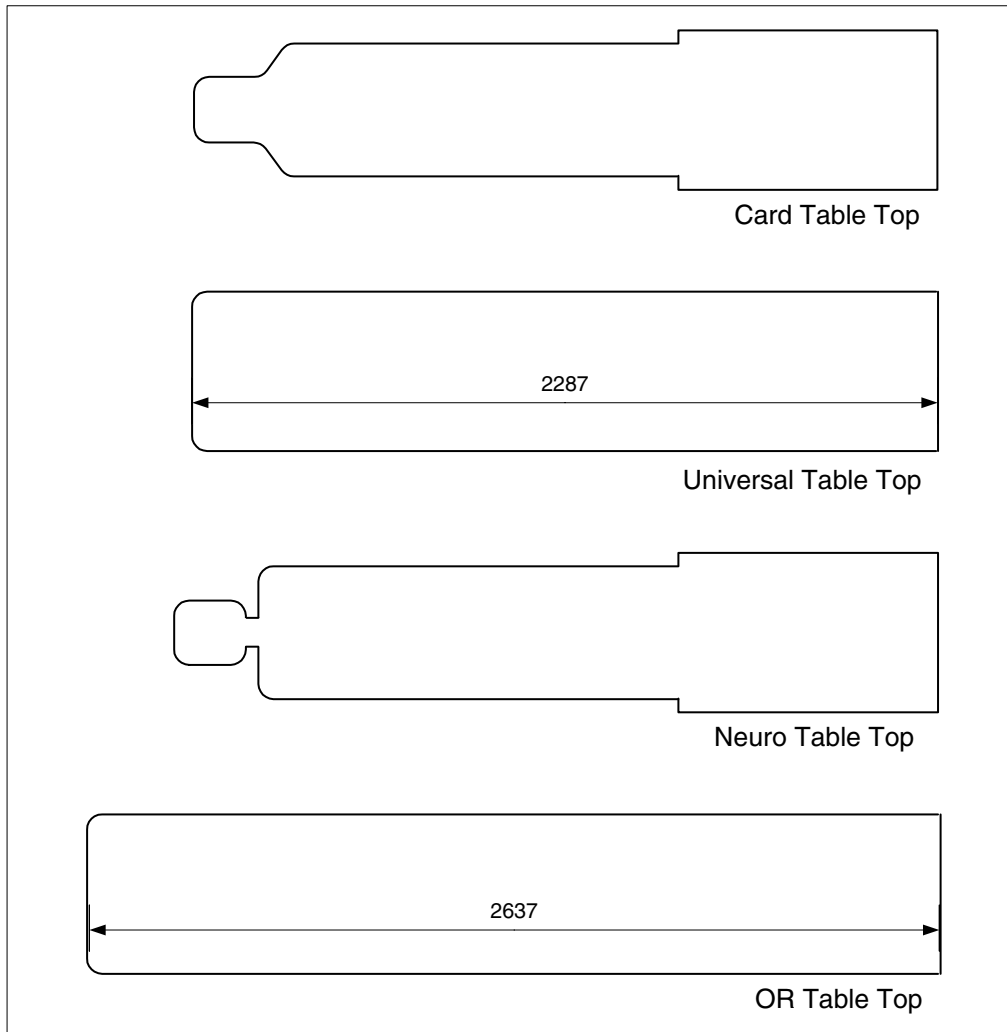

1. Start the service software.
2. Select **<Options><local Service>**.
3. After entering the password, the main menu will be displayed.

4. Select <Test Tools><Stand & Table Tests>:

Fig. 102: Stand Diagnostic functions

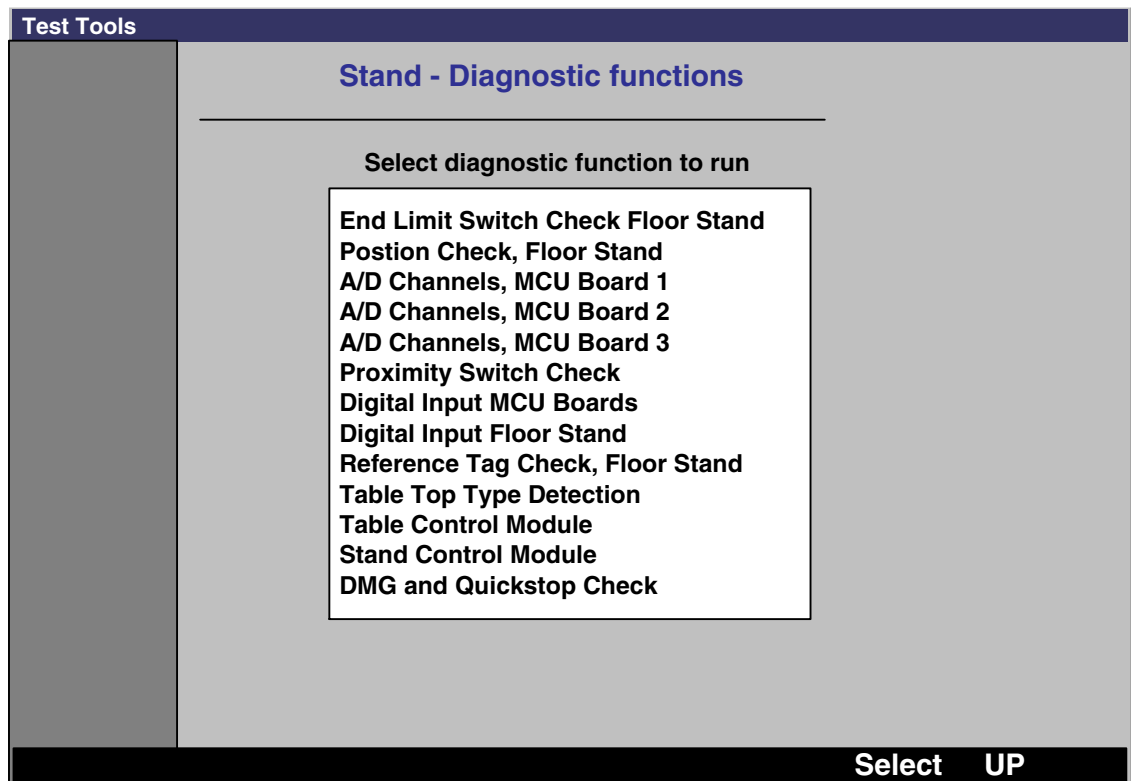

5. Select <Table Top Type Detection>.

6. Initiate the test with <Start>.

- » After a few seconds, the tabletop model that is sensed will be displayed (e.g. PLATE_CARD).

Fig. 103: Table Top Detection

Test Tools	
Test Tools	Table Top Type Detection
	Adjustment Duration :
	Adjustment Status : Running
	Runtime message sent by component :
	Runtime Data
Table Top Type : PLATE_CARD	

7. Insert the tabletops that are configured and check whether these are correctly sensed.



With the OR tabletop, "No Plate" is displayed for this test.

8. Then end the test.

SIE Testing Table Lift

1. Move the table all the way down until movement stops:
 - » Up movement must then be possible without problem.
2. Move the table all the way up until movement stops:
 - » Down movement must then be possible without problem.
3. The brakes for table longitudinal and table transverse movement must be released in every position (→ 1/ Fig. 95 Page 149) using the handswitch.

6.2.3.1 Tilting Table only, Part No. 5767020 and OR table, Part No. 5767053

SIE Testing Table Tilt

1. Move the table in the Trendelenburg position until movement stops:
 - » Then movement back into the up position must be possible without problem.
2. When the handswitch is pressed for the table brakes (→ 1/ Fig. 95 Page 149), the table longitudinal brake may not be released for further movement in the Trendelenburg position nor in the up position. Only table transverse movement is enable (if selected

- (→ 3/ Fig. 95 Page 149)). Only table longitudinal movement may be possible using the motor.
3. Press the "Table Up" and "Table Down" buttons at the same time.
 - » The table must stop in the middle position (0° position).
The brakes for table longitudinal and table transverse movement must be released again in the 0° position.
 4. Move the tabletop all the way to the head end direction to the mechanical end stop.
 5. Press the button for table tilt into the Trendelenburg position:
 - » The tabletop will move back approx. 3 cm with the motor until the head-end safety limit switch for longitudinal movement is no longer pressed. Then the tabletop will tilt in the Trendelenburg direction.
 6. Position the tabletop horizontally again and move the tabletop all the way to the foot end to the mechanical end stop.
 7. Press the button for table tilt into the Trendelenburg position:
 - » The tabletop will move back approx. 3 cm with the motor until the foot-end safety limit switch for longitudinal movement is no longer pressed. Then the tabletop will tilt in the Trendelenburg direction.

6.2.4 Periodic Preventive Maintenance

PMP Cleaning / Lubricating

1. Move the table all the way up and remove the tabletop.
2. Remove cover panels (1), (3), (4) and (5):

Fig. 104: Removing the cover panel

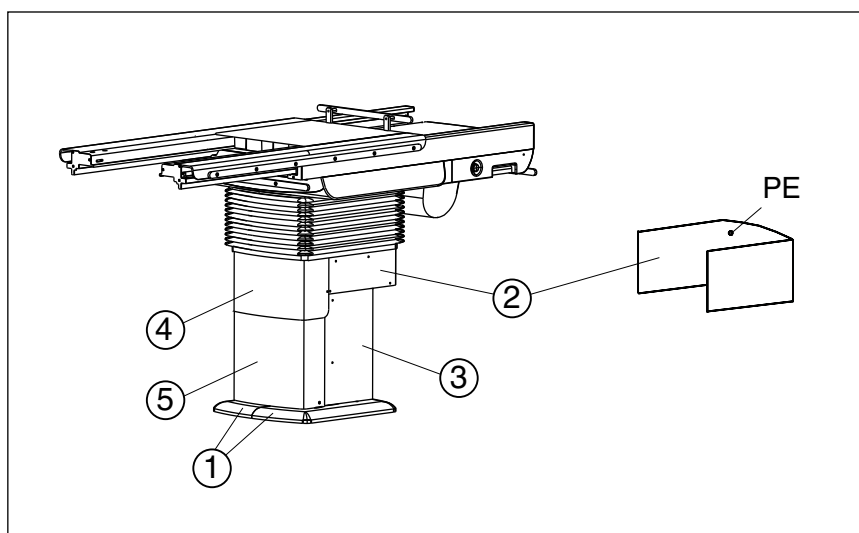

3. Install the lift safety stud (→ Patient Table / Page 13).

⚠ WARNING

When working inside the table base, serious injury can occur if there is unintentional lowering of the table. With tilting tables, there is also a risk of crushing between the tilt support and the lift unit if there is unintentional tilting.

- » Insert the safety aids (lift safety stud and, if applicable, the tilt safety brackets) included in the shipment.

4. Clean the following parts with alcohol or mineral spirits and lightly lubricate them (lubricating coating that is scarcely visible!):

Unit Part	Cleaning	Lubrication
Contact surfaces, longitudinal carriage (→ 1/Fig. 105 Page 156)	WD40 contact spray	n.a.
Contact surfaces, transverse carriage (→ 2,3/Fig. 105 Page 156)	WD40 contact spray	n.a.
Gear for table rotation (→ 1/Fig. 106 Page 156)	WD40 contact spray	Longtime PD2

Fig. 105: Table, cleaning

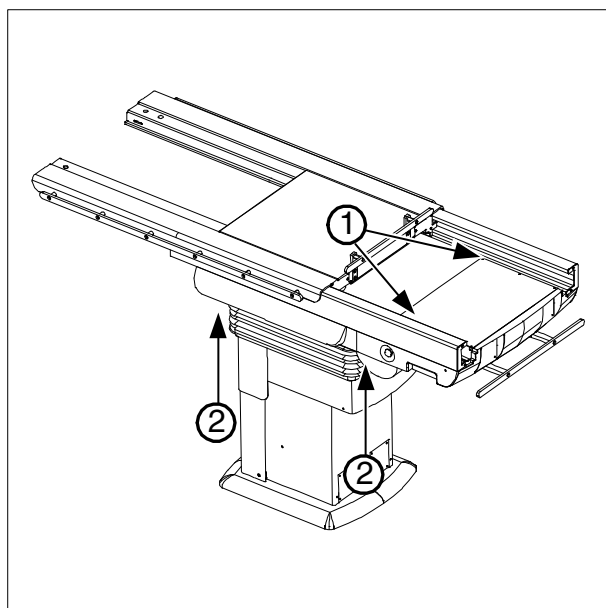
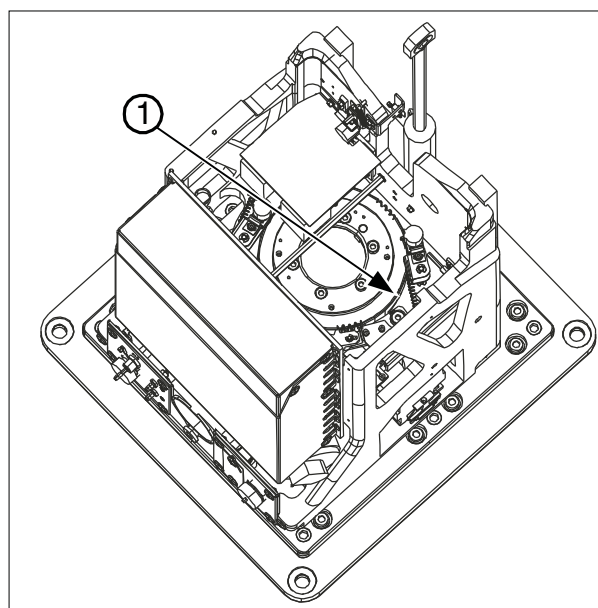

Fig. 106: Table, lubrication



6.2.5 Final Work Steps

6.2.5.1 Installing the Cover Panels on the Table

1. Reinstall all cover panels that were removed.

6.2.5.2 Clean table, repair any damage to painted surfaces

PMP Clean table, repair any damage to painted surfaces

1. Clean the table, cables, and the corrugated hose.
2. If necessary, touch up chips/scratches in the paint finish.

6.2.5.3 Electrical Safety

SIE Cables and Connectors

1. Check visible cables and connectors for damage.

6.3 Heated patient mattress

PMP Check, document 24-month maintenance interval



Note, valid only for Germany:

The following tests and inspections in chapter "Heated Patient Mattress" also apply as Sicherheitstechnische Kontrolle (STK) according to §11 MPBetreibV

6.3.1 Visual inspection, mattress

- SI Labels are legible and complete
- SI No damage to connection block
- SI No damage to connection cable
- SI No damage to plug
- SI No damage to sleeve

6.3.2 Visual inspection, control module

- SI Labels are legible and complete
- SI Attachment equipment function
- SI No damage to housing
- SI No damage to front panel
- SI No damage to power cable
- SI No damage to equipment plug

6.3.3 Visual inspection, power supply

- SI Labels are legible and complete
- SI Attachment equipment function
- SI No damage to housing
- SI No damage to power outlet
- SI No damage to power cable
- SI No damage to equipment plug

6.3.4 Operating and test components

6.3.4.1 Control panel

Fig. 107: Control panel components

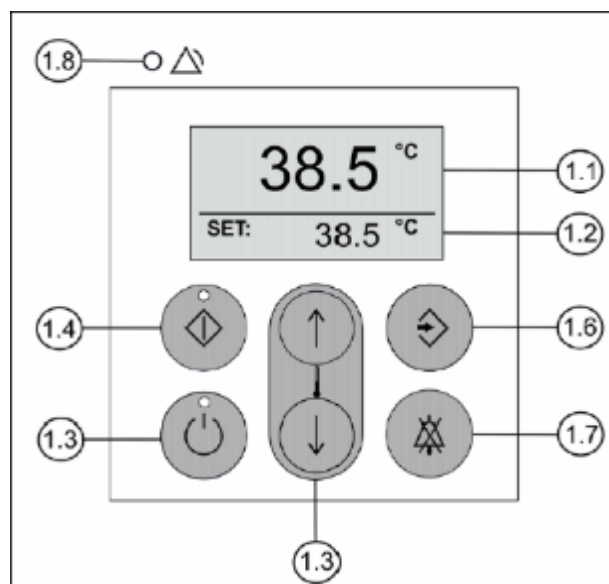

No.	Designation	Description
1.1	Actual Temperature	Shows the current temperature of the application part.
1.2	Required Temperature (SET)	Shows the set required temperature of the application part.
1.3	"Standby" Button	Button with blue LED. Turns the control panel on and off. LED lights up in standby. LED goes out when heating process starts.
1.4	"Start" Button	Button with green LED. Press this button to start the heating process. Or press this button to confirm a change in the required temperature. LED flashes if the heating process has not yet started. LED lights up if the heating process was started.
1.5	Arrow Keys	Adjustment keys to lower or raise the required temperature.
1.6	"Set" Button	Button to save a new starting required temperature.
1.7	Suppress Alarm Button	Turns off the power failure alarm. (Switches off acoustic alarm only).
1.8	"Alarm" LED (yellow)	Alarm LED (yellow) flashes and acoustic alarm sounds in the event of an alarm.

6.3.4.2 System Test Box

Fig. 108: Test box front

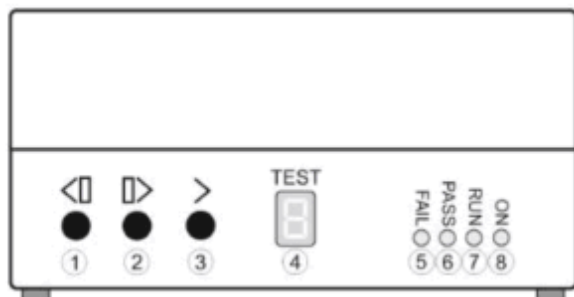
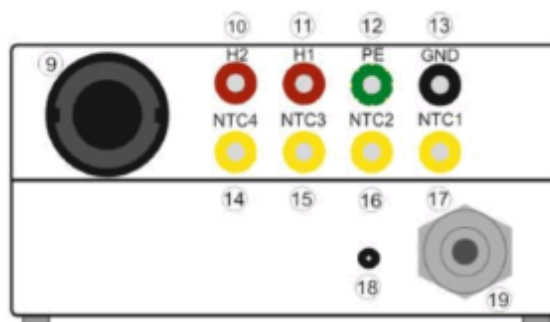

Fig. 109: Test box rear



No	Designation	No.	Designation
1	Back button	9	Connection socket for heated mattress
2	Forward button	10	Test socket for heating resistor
3	Start button	11	Test socket for heating resistor
4	Test no. display	12	Test socket for measuring resistance between heat and ground wire
5	FAIL LED (red)	13	Ground test socket for measuring sensor resistance
6	PASS LED (green)	14-17	Test sockets for sensor resistance
7	RUN LED (orange)	18	Power supply connection socket
8	ON LED (green)	19	Control panel connection cable

6.3.4.3 Test connector

Fig. 110: Test plug



Test connector for measuring ground wire resistance and the equivalent patient leakage current

6.3.5 Checking the Control Panel

Test set-up

Fig. 111: Test mounting MC

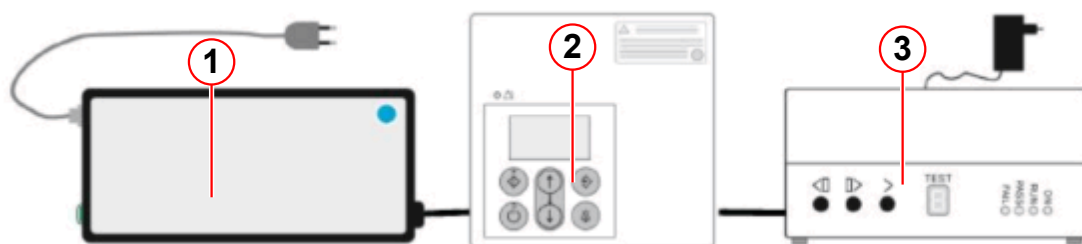



- (1) Power supply
- (2) Mattress Control module
- (3) System test box





Control panel function test

- Turn on the power supply switch.
 - » Switch on the power supply lights up green.
 - » Standby LED  is illuminated blue.



Display equipment test

- Press the Standby button  to turn on the control panel.
 - » Blue Standby LED goes out.
 - » The device carries out a self-test, green Start LED  flashes; yellow Alarm LED  flashes and acoustic alarm sounds to confirm that the control panel is functioning properly.
 - » Display of saved required initial temperature (→ 1.2/Fig. 107 Page 159).







Temperature display test – Test 1

1. On the test box, use the  button to select Test "1".
2. On the control panel, press the arrow key  for raising/lowering the temperature to set the required temperature (→ 1.2/Fig. 107 Page 159) to **39 °C**.
3. Press and hold the "Start" button  until the acoustic alarm turns off.
4. On the test box, start the test by pressing the  button.
 - » "PASS" and "FAIL" LEDs alternately flash.
 - » Blue Standby LED  goes out.
 - » A value between **35.5 °C** and **36.5 °C** must display on the required (→ 1.2/Fig. 107 Page 159) and actual temperature (→ 1.1/Fig. 107 Page 159) display.

PMF Temperature display test – Test 1**Temperature display test – Test 2**

1. On the test box, use the  button to select Test "2".
2. On the test box, start the test by pressing the  button.
 - » "PASS" and "FAIL" LEDs alternately flash.
 - » A value between **41.5 °C** and **42.5 °C** must display on the required (→ 1.2/Fig. 107 Page 159) and actual temperature (→ 1.1/Fig. 107 Page 159) display.
3. Turn off the control panel by pressing the Standby  button.

PMF Temperature display test – Test 2**Temperature control test – Test 3**

1. On the test box, use the  button to select Test "3".
2. Turn on the control panel by pressing the Standby  button.
3. On the control panel, press the arrow key  for raising/lowering the temperature to set the required temperature (→ 1.2/Fig. 107 Page 159) to **37 °C**.
4. "Start" button  must be pressed and held until the acoustic alarm turns off.
 - » The "Start"  LED flashes green until the "Start" button is pressed to confirm.
 - » The display (→ 1.1/Fig. 107 Page 159) alternately shows a value between **37.5 °C** and **38.5 °C** and "A2".
5. On the test box, start the test by pressing the  button.
 - » "ON" LED lights up green.
 - » "RUN" LED lights up orange.
 - » The "PASS" LED lights on successful completion of the test.
 - » The "FAIL" LED lights if the test fails.
 - » "RUN" LED goes out.
 - » The display (→ 1.1/Fig. 107 Page 159) alternately shows a value between **37.5 °C** and **38.5 °C** and "A2".
 - » "Start"  LED lights green.







PMF Temperature control test – Test 3**Temperature control test – Test 4**

1. On the test box, use the  button to select Test "4".

2. On the test box, start the test by pressing the  button.
 - » "ON" LED lights up green.
 - » "RUN" LED lights up orange.
 - » The "PASS" LED lights on successful completion of the test.
 - » The "FAIL" LED lights if the test failed.
 - » "RUN" LED goes out.





PMF Temperature control test – Test 4

Alarm switch-off test – Test 5

1. On the test box, use the  button to select Test "5".
 - » "Start"  LED lights green.
 - » The display (→ 1.1/Fig. 107 Page 159) alternately shows **40.5 °C ± 0.2 °C** and "A2".
2. Press and hold the  button on the test box until the acoustic alarm sounds.
 - » "ON" LED lights up green.
 - » "PASS" and "FAIL" LEDs alternately flash.
 - » The display (→ 1.1/Fig. 107 Page 159) alternately shows a value between **40.3 °C** and **40.7 °C** and "A2".
 - » "Start"  LED flashes green.
 - » "Alarm"  LED flashes yellow.
 - » An acoustic alarm is triggered on the control panel.
3. Press the "Start"  button.
 - » Acoustic alarm turns off.

PMF Alarm switch-off test – Test 5

Alarm switch-off test – Test 6

1. On the test box, use the  button to select Test "6".
2. Press and hold the  button on the test box until the acoustic alarm sounds.
 - » "ON" LED lights up green.
 - » "PASS" and "FAIL" LEDs alternately flash.
 - » The display (→ 1.1/Fig. 107 Page 159) alternately shows a value between **40.3 °C** and **40.7 °C** and "A2".
 - » "Start"  LED flashes green.
 - » "Alarm"  LED flashes yellow.
 - » An acoustic alarm is triggered on the control panel.

3. Press the **"Start"**  button.



- » Acoustic alarm turns off.

PMF Alarm switch-off test – Test 6

Alarm switch-off test – Test 7

1. On the test box, use the  button to select Test **"7"**.

2. Press and hold the  button on the test box until the acoustic alarm sounds.

- » **"ON"** LED lights up green.
- » **"PASS"** and **"FAIL"** LEDs alternately flash.
- » The display (→ 1.1/Fig. 107 Page 159) alternately shows a value between **40.3 °C** and **40.7 °C** and **"A2"**.
- » **"Start"**  LED flashes green.
- » **"Alarm"**  LED flashes yellow.
- » An acoustic alarm is triggered on the control panel.

3. Press the **"Start"**  button.



- » Acoustic alarm turns off.

PMF Alarm switch-off test – Test 7

Alarm switch-off test – Test 8

1. On the test box, use the  button to select Test **"8"**.





2. Press and hold the  button on the test box until the acoustic alarm sounds.

- » **"ON"** LED lights up green.
- » **"PASS"** and **"FAIL"** LEDs alternately flash.
- » The display (→ 1.1/Fig. 107 Page 159) alternately shows a value between **40.3 °C** and **40.7 °C** and **"A2"**.
- » **"Start"**  LED flashes green.
- » **"Alarm"**  LED flashes yellow.
- » An acoustic alarm is triggered on the control panel.







3. Press the **"Start"**  button.

- » Acoustic alarm turns off.







PMF Alarm switch-off test – Test 8**Wire breakage alarm test – Test 9**

1. On the test box, use the  button to select Test "9".
 - » "Start"  LED lights green.
 - » The display (→ 1.1/Fig. 107 Page 159) alternately shows a value between **37.8 °C** and **38.2 °C** and "A2".
2. Press and hold the  button on the test box until the acoustic alarm sounds.
 - » "ON" LED lights up green.
 - » As long as the test is running the "RUN" LED lights up orange.
 - » "PASS" and "FAIL" LEDs alternately flash.
 - » The display (→ 1.1/Fig. 107 Page 159) alternately shows a value between **35.5 °C** and **36.5 °C** and "A1".
 - » "Start"  LED flashes green.
 - » "Alarm"  LED flashes yellow.
 - » An acoustic alarm is triggered on the control panel.







PMF Wire breakage alarm test – Test 9**Wire breakage alarm test – Test A**

1. On the test box, use the  button to select Test "A".
2. Press the "Start"  button.
 - » Acoustic alarm turns off.
 - » "Start"  LED lights green.
 - » The display (→ 1.1/Fig. 107 Page 159) alternately shows a value between **37.5 °C** and **38.5 °C** and "A2".
3. Press and hold the  button on the test box until the acoustic alarm sounds.
 - » "ON" LED lights up green.
 - » As long as the test is running the "RUN" LED lights up orange.
 - » "PASS" and "FAIL" LEDs alternately flash.
 - » The display (→ 1.1/Fig. 107 Page 159) alternately shows a value between **35.5 °C** and **36.5 °C** and "A1".
 - » "Start"  LED flashes green.
 - » "Alarm"  LED flashes yellow.
 - » An acoustic alarm is triggered on the control panel.







PMF Wire breakage alarm test – Test A**Wire breakage alarm test – Test B**

1. On the test box, use the  button to select Test "B."
2. Press the "Start"  button.
 - » Acoustic alarm turns off.
 - » "Start"  LED lights green.
 - » The display (→ 1.1/Fig. 107 Page 159) alternately shows a value between **37.5 °C** and **38.5 °C** and "A2".
3. Press and hold the  button on the test box until the acoustic alarm sounds.
 - » "ON" LED lights up green.
 - » "PASS" and "FAIL" LEDs alternately flash.
 - » "Start"  LED flashes green.
 - » "Alarm"  LED flashes yellow.
 - » An acoustic alarm is triggered on the control panel.
 - » The display (→ 1.1/Fig. 107 Page 159) alternately shows a value between **37.5 °C** and **38.5 °C** and "A2".



PMF Wire breakage alarm test – Test B**Wire breakage alarm test – Test C**



1. On the test box, use the button  to select Test "C."
2. Press the "Start"  button.
 - » Acoustic alarm turns off.
 - » "Start"  LED lights green.
 - » The display (→ 1.1/Fig. 107 Page 159) alternately shows a value between **37.5 °C** and **38.5 °C** and "A2".
3. Press and hold the  button on the test box until the acoustic alarm sounds.
 - » "ON" LED lights up green.
 - » "PASS" and "FAIL" LEDs alternately flash.
 - » "Start"  LED flashes green.
 - » "Alarm"  LED flashes yellow.
 - » An acoustic alarm is triggered on the control panel.
 - » The display (→ 1.1/Fig. 107 Page 159) alternately shows a value between **37.5 °C** and **38.5 °C** and "A2".

PMF Wire breakage alarm test – Test C**Heat monitoring test – Test D**

1. On the test box, use the  button to select Test "D."
2. Press the "Start"  button.
 - » Acoustic alarm turns off.
 - » "Start"  LED lights green.
 - » The display (→ 1.1/ Fig. 107 Page 159) alternately shows a value between **37.5 °C** and **38.5 °C** and "A2".
3. To start the test, press the  button on the test box.
 - » "ON" LED lights up green.
 - » "RUN" LED lights up orange.
 - » The "PASS" LED lights on successful completion of the test; the "FAIL" LED lights if the test failed.
 - » "Start"  LED flashes green.
 - » "Alarm"  LED flashes yellow.
 - » An acoustic alarm is triggered on the control panel.
 - » The display (→ 1.1/ Fig. 107 Page 159) alternately shows a value between **37.5 °C** and **38.5 °C** and "A2".



PMF Heat monitoring test – Test D**Heat monitoring test – Test E**

1. On the test box, use the  button to select Test "E."
2. Press the "Start"  button.
 - » Acoustic alarm turns off.
 - » "Start"  LED lights green.
 - » The display (→ 1.1/ Fig. 107 Page 159) alternately shows a value between **37.5 °C** and **38.5 °C** and "A2".

3. To start the test, press the  button on the test box.
 - » "ON" LED lights up green.
 - » "RUN" LED lights up orange.
 - » The "PASS" LED lights on successful completion of the test; the "FAIL" LED lights if the test failed.
 - » "Start"  LED flashes green.
 - » "Alarm"  LED flashes yellow.
 - » An acoustic alarm is triggered on the control panel.
 - » The display (→ 1.1/Fig. 107 Page 159) alternately shows a value between **37.5 °C** and **38.5 °C** and "A2".

PMF Heat monitoring test – Test E

Power failure alarm test

1. Turn off mains power at the switch.
 - » The entire display goes out.
 - » "Alarm"  LED flashes yellow.
 - » An acoustic alarm is triggered on the control panel.
2. Press the "Suppress Alarm"  button.
 - » Acoustic alarm turns off.
 - » "Alarm"  LED flashes yellow.



The control panel should be connected to the switched-on power supply for at least 5 minutes before the test. If the test is interrupted, the control panel must be turned off and the test performed from the beginning.

PMF Power failure alarm test

6.3.5.1 Control module, inspection result

- SI** No safety and functional defects found.
- SI** No direct risk; the deficiencies discovered can be corrected quickly.
- SI** Device does not meet specifications and must be taken out of service to correct the defect.

6.3.6 Heated mattress check

6.3.6.1 Test set-up

Fig. 112: Test mounting HM

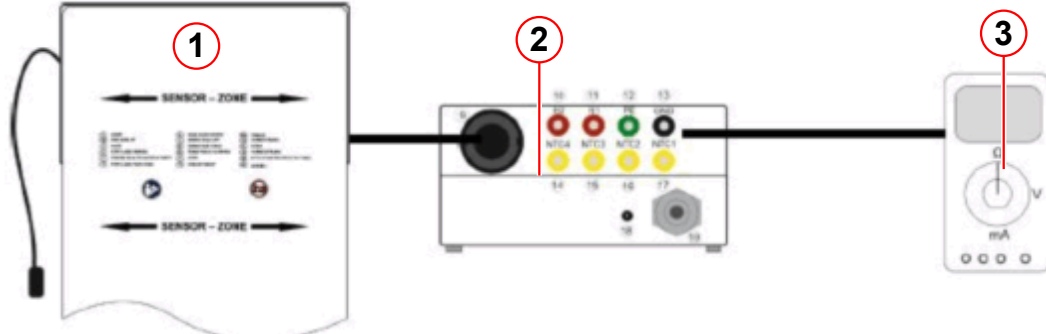

- (1) Heated Mattress CARD / UNI
- (2) System test box
- (3) Ohmmeter

6.3.6.2 Sensor resistance test (sensor test)

Testing the resistance values enables checking all four temperature sensors of the mattress.



Prior to the test, the heated mattress must be stored at room temperature for 2 hours in the switched-off state. The following tests must be performed at a room temperature of approx. **20°C** to **26°C**. The mattress should not be exposed to drafts or sunlight during the test.

PMF Room temperature



1. Measure the room temperature and enter the measured value of the temperature sensor into the test protocol. Do not enter the temperature until the display has stopped at a fixed value.

PMF Set value of resistance



1. Select the set value of the resistance from the following set value table and enter it into the test protocol.

Fig. 113: Specified values for sensor test

°C	CARD / UNI Ω	°C	CARD / UNI Ω
10	3683,5	27	1850,9
10,5	3606,1	27,5	1815,7
11	3530,5	28	1781,2
11,5	3456,7	28,5	1747,5
12	3384,7	29	1714,5
12,5	3314,4	29,5	1682,2
13	3245,7	30	1650,7
13,5	3178,7	30,5	1619,8
14	3113,3	31	1589,5
14,5	3049,3	31,5	1560,0
15	2986,9	32	1531,0
15,5	2926,0	32,5	1502,7
16	2866,4	33	1474,9
16,5	2808,3	33,5	1447,8
17	2751,4	34	1421,2
17,5	2695,9	34,5	1395,2
18	2641,7	35	1369,8
18,5	2588,7	35,5	1344,8
19	2537,0	36	1320,4
19,5	2486,4	36,5	1296,5
20	2437,0	37	1273,1
20,5	2388,7	37,5	1250,2
21	2341,4	38	1227,8
21,5	2295,3	38,5	1205,8
22	2250,2	39	1184,3
22,5	2206,1	39,5	1163,2
23	2163,0	40	1142,6
23,5	2120,9	40,5	1122,3
24	2079,7	41	1102,5
24,5	2039,4	41,5	1083,1
25	2000,0	42	1064,1
25,5	1961,5	42,5	1045,5
26	1923,8	43	1027,2
26,5	1887,0		

PMF Measurement value NTC1

1. Plug in the heated mattress on the back of the system test box.
2. Plug an ohmmeter test cable into the "GND" jack.
3. Plug the second ohmmeter test cable into the "NTC1" jack.
4. Enter the measurement value.

**PMF** Measurement value NTC2

1. Plug the ohmmeter test cable into the "NTC2" jack.
2. Enter the measurement value.

**PMF** Measurement value NTC3

1. Plug the ohmmeter test cable into the "NTC3" jack.
2. Enter the measurement value.

**PMF** Measurement value NTC4

1. Plug the ohmmeter test cable into the "NTC4" jack.
2. Enter the measurement value.



PMF Deviation between values measured from NTC1 to NTC 4 (threshold: max. 200 Ohms)

The difference between the lowest and highest value measured at measurement jacks NTC 1 through NTC 4 may not exceed 200 Ω.

PMF Deviation between measured value NTC1-4 and nominal value (threshold: max. +/- 200 Ohms)

The difference between the lowest and highest value measured at measurement jacks NTC 1 through NTC 4, and the **nominal value**, may not exceed $\pm 200 \Omega$.

6.3.6.3 Heat resistance test



The ohmmeter used should have a measurement range of 200 mV to prevent any electrostatic charge in the heating element from influencing the resistance measurement and to ensure the measurement is sensitive enough.

1. Plug in the heated mattress on the back of the system test box.
2. Plug the ohmmeter for the resistance measurement in the "H1" and "H2" jacks of the system test box.
3. During the resistance test, the mattress should be rolled up several times along its transverse and longitudinal axis. Do not kink the heated mattress! Observe the ohmmeter display during the mechanical stress.
 - » The heating resistance should not exceed the defined threshold of $5,5 \pm 0,5 \Omega$.



4. Enter the measured value into the protocol.

PMF Check the heating resistance (nominal: 5.5 +/- 0.5 Ohm)

6.3.6.4 Test of resistance between functional ground and heating

1. Plug in the heated mattress on the back of the system test box.
2. Plug an ohmmeter cable into the "GND" jack.
3. Plug the second ohmmeter test cable into the green/yellow "PE" jack.
 - » There should be no measurable value.

6.3.6.5 Mattress, inspection results

- SI** No safety and functional defects found.
- SI** No direct risk; the deficiencies discovered can be corrected quickly.
- SI** Device does not meet specifications and must be taken out of service to correct the defect.

6.3.7 Power supply test

6.3.7.1 Test set-up

Fig. 114: Test mounting

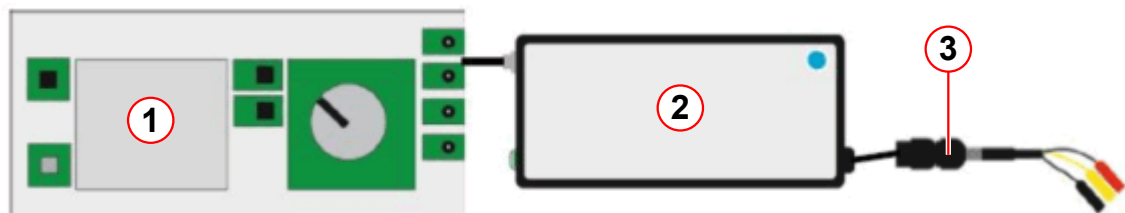

- (1) Safety tester
- (2) Power Supply
- (3) Test plug

6.3.7.2 Protective Conductor Resistance

1. Check the protective conductor resistance using a suitable, calibrated test device.
2. To measure the protective conductor resistance to the power plug, plug the test probe of the safety tester into the yellow jack of the test plug.
3. Enter the measurement value.



SIE Check the ground wire resistance (nominal: Max. 0.3 ohms)

6.3.7.3 Equivalent equipment leakage current

1. Check the ground leakage current using a suitable, calibrated testing device.
2. Conduct the test as specified by the safety tester.
3. Enter the measurement value.



SIE Measure the equivalent device leakage current (nominal: max. 0.5 mA)

6.3.7.4 Equivalent patient leakage current

1. Connect the measurement probe of the safety tester to the red or the black jack of the test plug.
2. Plug the power plug of the unit under test into the safety tester.
 - » The test device feeds 230V at the test jack and measures the current that drains off to the PE.
3. Enter the measurement value.



SIE Measure the equivalent patient leakage current (nominal: Max. 5 mA)

6.3.7.5 Power supply, inspection results

- SI** No safety and functional defects found.
- SI** No direct risk; the deficiencies discovered can be corrected quickly.
- SI** Device does not meet specifications and must be taken out of service to correct the defect.

6.3.8 STK inspection label (for Germany only)



This work step should be performed only in the area where MPBetreibV is valid (Germany)

SIE Affix the STK inspection label (Germany only)

After successful testing, an inspection seal (STK label, order through WebLogX) has to be applied:

1. Affix the STK inspection label (→ Fig. 115 Page 174) at a suitable location on the mattress control module (possibly over the existing label).
2. Mark the next testing date (month and year, 2 years hence) with a waterproof marker.

Fig. 115: STK Label



6.4 Uninterruptible power supply



Maintenance work on the UPS (e.g. from the Powerware Company) may be performed only by the manufacturer of the UPS or by personnel who have been trained by the manufacturer of the UPS!

6.4.1 Mechanical Safety



Maintenance work on the UPS (e.g. from the Powerware Company) may be performed only by the manufacturer of the UPS or by personnel who have been trained by the manufacturer of the UPS!

6.4.2 Electrical Safety



Maintenance work on the UPS (e.g. from the Powerware Company) may be performed only by the manufacturer of the UPS or by personnel who have been trained by the manufacturer of the UPS!

6.4.3 Periodic Preventive Maintenance

Applies only for the 40 kVA UPS or for Diesel (depending on the configuration), but not for the OR UPS / Table UPS / 15 kVA UPS:



CAUTION

The system fails to reduce power in case of power failure, while supplied from the Uninterrupted Power Supply.

System unavailable during Power failure.

» **Perform the check of the UPS signal as part of each regular maintenance.**

hm_serv_UPSFunctionTest

Applies only for the 40 kVA UPS or for Diesel (depending on the configuration), but not for the OR UPS / Table UPS / 15 kVA UPS:



Maintenance work on the UPS (e.g. from the Powerware Company) may be performed only by the manufacturer of the UPS or by personnel who have been trained by the manufacturer of the UPS!

PMP UPS Signal

UPS = Uninterruptible Power Supply



1. Jumper the X30 connector, Pins 3 and 4, on the system Real-time Controller (RTC).
2. Following reset of the power unit, press the fluoroscopy footswitch.
 - » Only power-reduced, emergency fluoroscopy is possible and "Emergency Power" is displayed on the display.
3. Trigger all operating modes on the footswitch.
 - » Triggering all remaining operating modes is blocked.
The image system will continue working without interruption and all unit movements will be possible.
Emergency fluoroscopy, including unit movements, is possible for about 10 minutes.
4. Remove the jumper on the X30 connector between Pins 3 and 4 and manually set the system back to line power.

6.4.4 Upkeep



Maintenance work on the UPS (e.g. from the Powerware Company) may be performed only by the manufacturer of the UPS or by personnel who have been trained by the manufacturer of the UPS!

6.4.5 Function Inspection

Applies only for the 40 kVA UPS or for Diesel (depending on the configuration), but not for the OR UPS / Table UPS / 15 kVA UPS:



CAUTION

The system fails to reduce power in case of power failure, while supplied from the Uninterrupted Power Supply.

System unavailable during Power failure.

- » Perform the check of the UPS signal as part of each regular maintenance.

hm_serv_UPSFunctionTest

PMP Checking the Function of the UPS

6.4.5.1 Emergency Power Supply for the complete System, incl. Fluoroscopy

There are 2 versions of this.

PMF Emergency Power Supply for the complete System, incl. Fluoroscopy, Function Test

Version 1, Emergency Power via UPS/ATS

1. Info:

Fig. 116: ATS remote control console

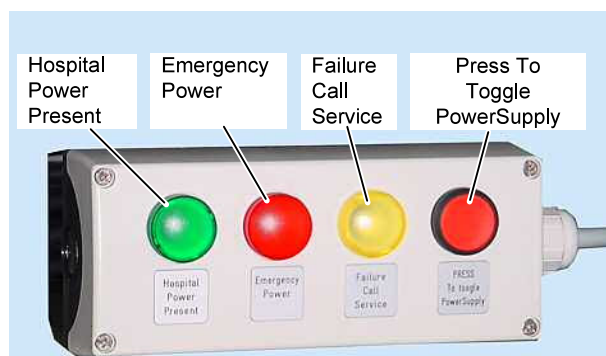

The model used for the emergency power supply mode, e.g. Powerware 9305 /9330 UL with Automatic Transfer Switch (ATS), combines a pure UPS mode for control of the Angio system with an uninterruptable switch-over of the generator from the line power to the UPS voltage, i.e. this is an emergency power supply for the complete system, incl. fluoroscopy for a period of approx. 10 min. during a primary line power failure.

2. Checking the Function:

a) Switch line power back on in front of the UPS:

- » Unit and table movements are possible, image system and monitors can be operated.
- » The ATS switches the power supply from the generator to the UPS. The generator boots up. Then emergency fluoroscopy is possible. Exposure is blocked. The entire routine, starting from failure of the primary line power supply to generator ready for emergency fluoroscopy takes approx. 25 sec.
- » Display of "Bypass Fluoro" or "Fluoro only on Power Backup"
- » ATS remote control console (→ Fig. 116 Page 177):
The red "Emergency Power" lamp goes on.

b) Switch line power back on in front of the UPS:

- » ATS remote control console: in addition to the red lamp, the green "Hospital Power Present" lamp will be on.

c) Briefly press the "Press To Toggle Power Supply" button on the ATS remote control console:

- » The ATS will switch the generator to the line power, i.e., the generator lose power and will then boot up again.
- » ATS remote control console: The red lamp goes off.
- » Data Display: The "Bypass ..." message is no longer displayed.
- » Exposure mode is enabled again.



Version 2, Emergency Power Supply from the Hospital's Central Backup Power System

1. Info:

If there is a failure of the primary line power, the line power supply is switched to the hospital's central backup power system. Since this does not take place without an interruption, the complete system is without power during the switch routine. Only after the switch-over routine has completed will it be possible to switch the system on again at the ACE. The Angio system exposure mode is blocked by the "Emergency Power On" signal and only emergency fluoroscopy is possible.

2. Checking the Function:

a) Open the external "emergency power on" contact.

- » Unit and table movements are possible, image system and monitors can be operated.
- » Display of "Bypass Fluoro" or "Fluoro only on Power Backup"
- » Emergency fluoroscopy is possible; triggering of exposure is blocked.



b) Open the external contact again:

- » The "Bypass ..." message is no longer displayed.
- » Exposure mode is enabled again.



6.4.5.2 Emergency Power for Table/Unit/Image System

This is an emergency power supply for uninterrupted switch-over of the line power supply for all unit and table movements, as well as for the unit and table movements for a period of approx. 10 min. during a failure of the primary line power supply.

PMF Emergency Power for Table/Unit/Image System

1. Switch of the line power in front of the UPS and the generator.

- » Unit and table movements must still be possible; it must still be possible to operate the image system and monitors.
- » DCS Data Display:
Display of "Bypass Fluoro" or "Fluoro only on Power Backup"
- » Fluoroscopy and exposure not possible (no power from generator).

2. Switch the line power back on.

- » Display on the DCS: The "Bypass ..." message is no longer displayed.

3. The generator boots up.

- » Radiation (fluoroscopy and exposure) is again possible after approx. 25 sec.



6.4.5.3 Emergency Power for the Image System

This version safeguards only the image system without the monitors during a power failure. If there is a failure of line power, the image system will be shut down automatically after 90 sec.

PMF Emergency Power for the Image System, Function Test

To check the function:

1. Switch on the system.
2. Once the system is ready, switch off the line power in front of the system.
 - » Except for the image system, the entire system will be without power.
 - » After 90 sec., the image system "Shutdown" will start automatically.
3. Wait until the "Shutdown" has finished. Then switch the system back to line power, switch on the system and wait for it to completely boot up.
4. Switch off line power to the system again.
 - » The image system will continue to run.
5. 60 sec. after shutting off line power, switch it on again.
 - » The RTC and the generator will boot up.
 - » The system will again be fully ready after approx. 2-3 minutes (unit movements and radiation possible).



6.5 IQAP Tests

6.5.1 Image Quality

QIQ IQAP Maintenance Test

Perform an IQAP "Maintenance Test" as follows:

1. Start the service software from the <OPTIONS> menu in the user interface menu line. Select <Local Service>.
2. Select the <Quality Assurance> menu item in the service user interface (already done in (→ Fig. 117 Page 180)).

Fig. 117: Quality Assurance, Maintenance Test

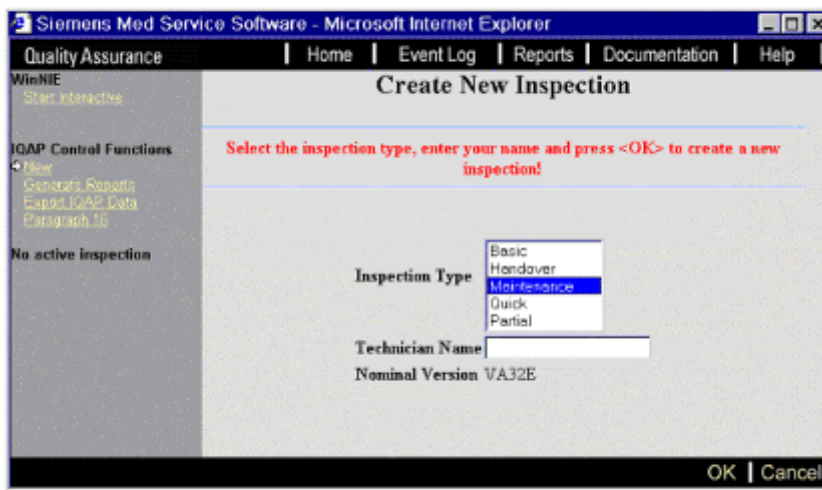

3. Select the Maintenance menu item and perform the checkpoints listed.

Fig. 118: Maintenance tests, details



6.5.2 InSpace3D IQAP Maintenance Tests

IQ InSpace3D IQAP Maintenance Test

If the "InSpace3D" option is installed, perform the following tests every 12 months:

1. Artis zee systems with VD11 software:

- **Automatic 3D Geometry Calibration Test**
Document: AX42-011.820.07.02.02, chapter: Automatic 3D Geometry Calibration Test
Link: (→ Automated 3D Geometry Calibration Test / AX42-011.820.07)
- **Registration Accuracy for 2D / 3D Applications**
Document: AX42-011.820.07.02.02, chapter: Registration Accuracy for 2D / 3D Applications
Link: (→ Registration Accuracy for 2D / 3D Applications / AX42-011.820.07)

2. Artis zee systems with VC21 software:**- Automatic 3D Geometry Calibration Test**

Document: AX42-011.820.05.04.02, chapter: Geometric Definition / Automatic 3D Geometry Calibration

Link: (→ [Geometric Definition / Automatic 3D Geometry Calibration Test / AX42-011.820.05](#))

- Registration Accuracy for 2D / 3D Applications

Document: AX42-011.820.05.04.02, chapter: Registration Accuracy for 2D / 3D Applications

Link: (→ [Registration Accuracy for 2D / 3D Applications / AX42-011.820.05](#))

3. Artis zee systems with VC14 software:**- Geometric definition / Spatial resolution**

Document: AX42-011.820.01.06.02, chapter: Geometric definition / Spatial resolution

Link: (→ [Geometric definition / Spatial resolution / AX42-011.820.01](#))

- Registration Accuracy for 2D / 3D Applications

Document: AX42-011.820.01.06.02, chapter: Registration Accuracy for 2D / 3D Applications

Link: (→ [iPilot Registration Accuracy / AX42-011.820.01](#))

6.6 Final Work Steps

6.6.1 Installing the Cover Panels

1. Reinstall all cover panels that have not yet been installed. When doing this, be absolutely sure to connect the ground wires if present.

6.6.2 Resetting the Maintenance Counter

PM Resetting the Maintenance Counter

1. Select **Local Service**.
2. Select the **Tune up** menu item in the service user interface and then select **System usage** under Maintenance.

Fig. 119: Maintenance, System Usage

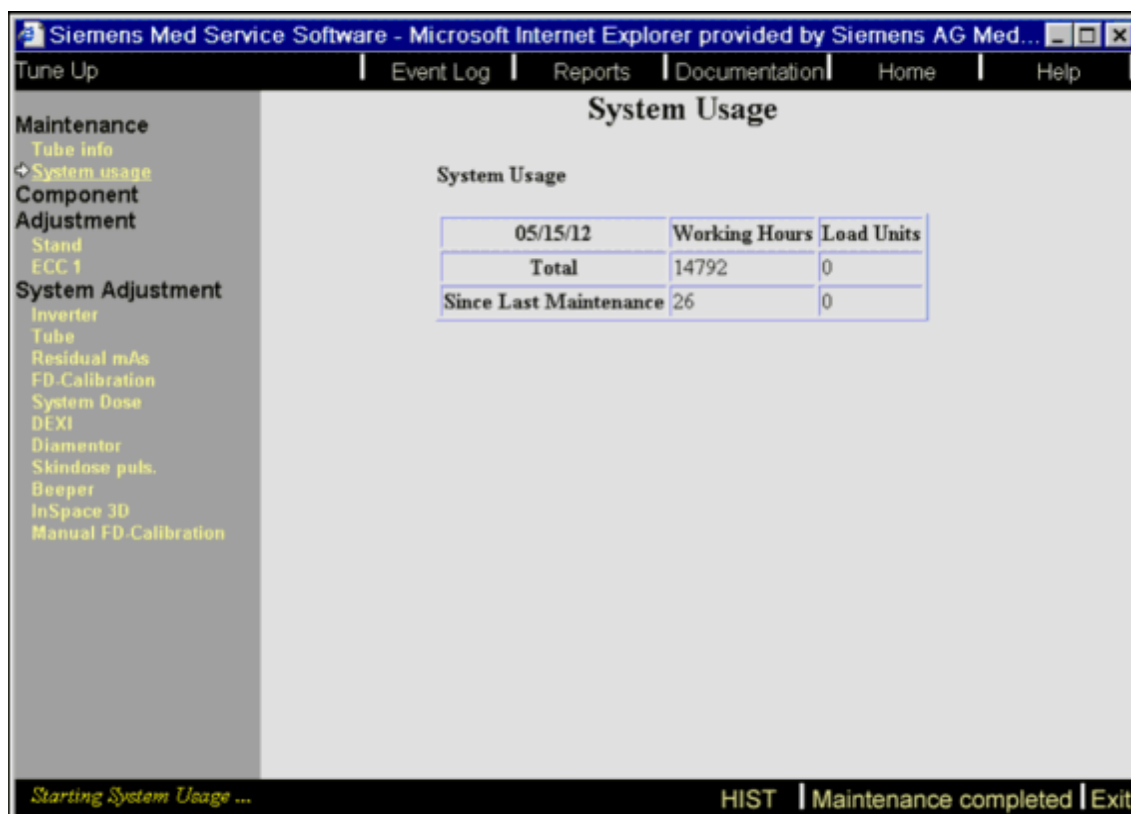

The screenshot shows the Siemens Med Service Software interface in Microsoft Internet Explorer. The browser title is "Siemens Med Service Software - Microsoft Internet Explorer provided by Siemens AG Med...". The page has a navigation bar with "Tune Up", "Event Log", "Reports", "Documentation", "Home", and "Help". The main content area is titled "System Usage" and contains a table with the following data:

05/15/12	Working Hours	Load Units
Total	14792	0
Since Last Maintenance	26	0

The left sidebar contains a menu with categories: Maintenance (Tube info, System usage, Component), Adjustment (Stand, ECC 1), and System Adjustment (Inverter, Tube, Residual mAs, FD-Calibration, System Dose, DEXI, Diamantor, Skindose puls., Beeper, InSpace 3D, Manual FD-Calibration). The status bar at the bottom shows "Starting System Usage ..." on the left and "HIST | Maintenance completed | Exit" on the right.

3. Select "Maintenance completed" in the action bar.

Fig. 120: Maintenance completed



4. Enter the completed maintenac with date in the "Please make your comments" empty text box and confirm with **OK**.
 - » The counter for Working hours and Load units is reset to zero.

6.6.3 Run a config and version check.

Config Check:

1. Select **Configuration > Config Check**.
 - » The Config Check is started and must finish without any "conflicts".
2. All "conflicts" are fixed by selecting **Auto Config**.
3. Exit the **Config Check** after a successful run with **Exit**.

Version Check:

1. Select **Configuration > Version Check**.
 - » The Version Check is started and must finish without any "conflicts".
2. Use the **Refresh** button if there are "conflicts".
3. If "conflicts" persist, switch the RTC off and on and repeat the Version Check.
If the problem still exists, download SW for the components causing the issue.
4. Exit the **Version Check** after a successful run with **Exit > Next (Finish)**.

PMF Run a config and version check.

6.6.4 Electrical Safety, Ground Wire Check

6.6.4.1 General information regarding ground wire testing as per IEC 62353

General measurement procedure:

Test the ground wire resistance between all conductible parts of the system that can be touched and the ground wire bus rail (in the generator, power distributor, for example).

Fig. 121: Ground wire measurement with fixed power line connection

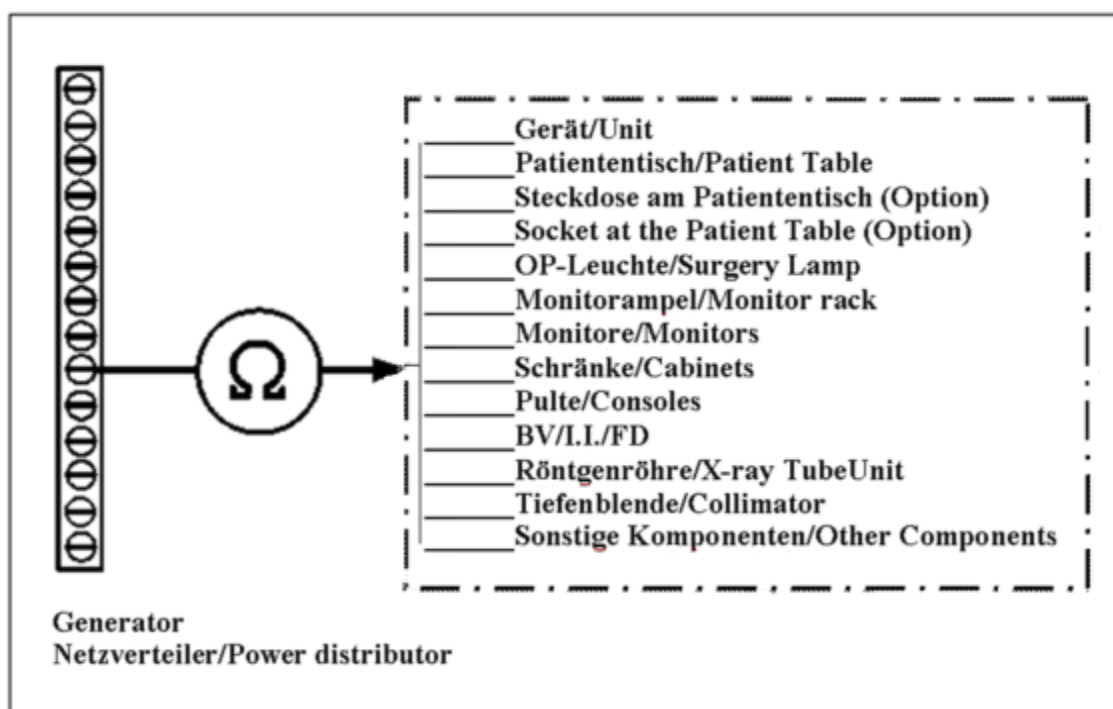

According to IEC 62353, the measured values from the old maintenance certificates as well as the startup certificate from the initial maintenance must be compared with the new measured values. If a significant difference is found or if the measured value exceeds **300 mΩ**, initiate corrective measures. Usually, the problem is that the ground wires are not connected or are incorrectly connected.



DANGER

Risk of accident due to electric shock!

- » Correct any incorrect ground wire connections prior to turning the unit over to the customer.

6.6.4.2 Ground wire measurement for the patient table (a Siemens or Trumpf table)

1. Switch off power to the system.
2. Measure the resistance between an exposed, conducting part on the table and the ground wire bus rail in the power distributor.
3. Record the value in the maintenance certificate.



SIE Ground wire measurement for the patient table ($\leq 300 \text{ m}\Omega$)

7.1 Protective ground wire test meter

7.1.1 Order directly

Info:

- The ground wire test meter (test meter) must meet the specifications of IEC 61557 / EN 61557 / VDE 0413 / IEC 62353,
e.g. the Universalprüfgerät SECUTEST® SIII or PROFITEST® 0100S-II; **order directly from:**

GMC-I Messtechnik GmbH

Südwestpark 15

D-90449 Nürnberg

Germany

Telephone +49 911 8602-0

Fax +49 911 8602-669

E-mail: info@gossenmetrawatt.com

<http://www.gossenmetrawatt.com>

7.2 Cleaning the Large Display, Cockpit and TFT Monitor

7.2.1 Cleaning Information



Information for cleaning agents/disinfectants apply only to the display to which this document refers.

Not the entire system!



Information about cleaning agents must be observed; if agents are used other than those listed, the display surface can be irretrievably damaged.

Cleaning agents may not remain on the surface for an extended period.

If this is not observed, the warranty is invalidated.

Equipment Care, Cleaning and Disinfection:

- The front of the display is very sensitive to mechanical damage; absolutely avoid scratches, shocks, etc.
- Promptly remove any drops of liquid that fall on it; extended contact with liquids may cause, for example, discoloration or calcium outlines on the surface.
- If there is dirt on the front of the display, clean it with a microfiber cloth and if necessary with a cleaning agent. Clean housing components only with the recommended cleaning agents.
- If a cleaning agent is sprayed directly on the display surface, make sure that any droplets that run down are wiped off with a microfiber cloth before they reach the edge of the panel.

Tab. 7 Cleaning Agents, general

Active ingredient class	Tested Cleaning Agents and Disinfectants	Additional examples
Alcohol	Ethyl alcohol, 96%	Hospiset cloth Microzoid liquid
Aldehyde	Melsitt Cidex	Aldasan 2000 Kohsolin Gigasept FF
Chloride derivative	Terralin	Quartamon Med
Disinfectants	Taski DS5001 (Diverseylever Labs) Morning Mist Surfanios Fraicheur Citron (Anios Labs)	
Guanidine derivatives	Lysoformin	

Active ingredient class	Tested Cleaning Agents and Disinfectants	Additional examples
Quaternary compounds	Incidur spray, full strength	
Commercially available dish washing liquid	Tempo	Fairy Ultra, Pril, Palmolive
Benzine	Petroleum ether	
Prydine derivatives	Activ Spray, full strength	
Water	Tap water Distilled water	



Effective time:

If the maximum time between applying the cleaning / disinfectant liquid and removal (e.g. by dry-wiping)

If the effective time is exceeded, damage to the surfaces can occur; with the panel, this can be permanent damage.

Tab. 8 Cleaning Agents, direct

Name	Effective time
Terralin protect; 2%	15 min.
Meliseptol rapid, direct	60 min.
Microbac [®] tissues, direct	30 min.
Incidin Plus, 8% Vol.	15 min.
Melsitt, 10% Vol.	60 min.
Incidur spray, full strength	60 min.
Perform, 3% Wt.	60 min.
Lysoformin, 2% Vol.	60 min.
Activ Spray, full strength	60 min.
Terralin, 0.5%	60 min.
Ethyl alcohol, 96%	90 min.
Commercially available dish washing liquid: Tempo	60 min.

Name	Effective time
Boiling range - benzine, full strength	Must not be used!
Spray disinfection: Disinfectants: Nocolyse Quantity: Recommended benchmark (manufacturer)	Information from manufacturer

Chapter	Section	Changes
Part 2: Generator / Support Arm System / DCS	Required materials	Tube unit coolant additive (biocide) - material number removed.
Part 2: Generator / Support Arm System / DCS	Preventive Maintenance	Work steps Work step removed: filling the tube unit cooling unit with biocide.

The list shows the Hazard IDs of this document.

- **hm_serv_HandleCoolingMediumWithCare**
 - The cooling fluid consists of a glycol-water mixture. This is hazardous to health if swallowed. Repeated skin contact can cause skin irritation. (Page 38)
- **hm_serv_UPSFunctionTest**
 - The system fails to reduce power in case of power failure, while supplied from the Uninterrupted Power Supply. (Page 176)(Page 175)
- **hm_serv_LabelPowerPresent**
 - Even after switching off the system (Shutdown), power is still present at the control cabinet and generator. (Page 14)
- **hm_serv_FdCoolHoseConnectorCare**
 - Leakage of FD Cooler cooling fluid into the system cabinet leads to electrical disturbances and damage to electronic components, e.g. short circuit in the power supply (Main Distributor), RTC, etc.. (Page 39)

All documents may only be used for rendering services on Siemens Healthcare Products. Any document in electronic form may be printed once. Copy and distribution of electronic documents and hardcopies is prohibited. Offenders will be liable for damages. All other rights are reserved.

siemens-healthineers.com

Siemens Healthineers Headquarters
Siemens Healthcare GmbH
Henkestr. 127
91052 Erlangen
Germany
Telephone: +49 9131 84-0
siemens-healthineers.com

Print No.: AXA4-070.831.02.11.02 | Replaces: AXA4-070.831.02.10.02
Doc. Gen. Date: 04.19 | Language: English
© Siemens Healthineers, 2014