

Data sheet

Differential pressure controller (PN 16)

AVP - return and flow mounting, adjustable setting

AVP-F - return mounting, fixed setting

Description

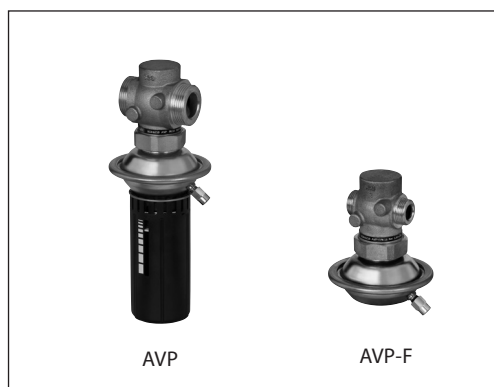

The controller has a control valve, an actuator with one control diaphragm and handle for differential pressure setting (fixed setting version is without handle).

Main data:

- DN 15-32
- k_{vs} 0.4 - 10 m³/h
- PN 16
- Setting range (AVP):
0.05 - 0.5 bar / 0.2 - 1.0 bar / 0.8 - 1.6 bar
- Fixed setting (AVP-F): 0.2 bar / 0.3 bar / 0.5 bar
- Temperature:
- Circulation water / glycolic water up to 30%:
2 ... 150 °C
- Connections:
- Ext. thread (weld-on, thread and flange tailpieces)

AVP(-F) is a self-acting differential pressure controller primarily for use in district heating systems. The controller closes on rising differential pressure.

Ordering

AVP Controller (return mounting)

Picture	DN (mm)	k_{vs} (m ³ /h)	Connection		Δp setting range (bar)	Code No.	Δp setting range (bar)	Code No.	Δp setting range (bar)	Code No.
	15	1.6	Cylindr. ext. thread acc. to ISO 228/1	G ¾ A	0.05 - 0.5	003H6200	0.2 - 1.0	003H6206	0.8 - 1.6	003H6212
		2.5				003H6201		003H6207		003H6213
		4.0				003H6202		003H6208		003H6214
	20	6.3		G 1 A		003H6203		003H6209		003H6215
	25	8.0		G 1¼ A		003H6204		003H6210		003H6216
	32	10		G 1¾ A		003H6205		-		003H6217

Note: other controllers available on request.

Example:

Differential pressure controller; return mounting; DN 15; k_{vs} 1.6; PN 16; setting range 0.2 - 1.0 bar; t_{max} 150 °C; ext. thread;

- 1x AVP DN 15 controller
Code No: **003H6206**

Option:

- 1x Impulse tube set AV, R 1/8
Code No: **003H6852**

- 1x Weld-on tailpieces
Code No: **003H6908**

The controller will be delivered completely assembled, inclusive impulse tube between valve and actuator. External impulse tube (AV) must be ordered separately.

AVP Controller (flow mounting)

Picture	DN (mm)	k_{vs} (m ³ /h)	Connection		Δp setting range (bar)	Code No.	Δp setting range (bar)	Code No.
	15	0.4	Cylindr. ext. thread acc. to ISO 228/1	G ¾ A	0.05 - 0.5	-	0.2 - 1.0	003H6947 ¹⁾
		1.0				-		003H6948 ¹⁾
		1.6				003H6238		003H6244
		2.5				003H6239		003H6245
		4.0				003H6240		003H6246
	20	6.3		G 1 A		003H6241		003H6247
	25	8.0		G 1¼ A		003H6242		003H6248
32	10	G 1¾ A	003H6243	-				

Note: other controllers available on request.

¹⁾ This version of controller can be mounted in return or in flow pipe. When ordering 2 impulse tube sets AV (instead of 1) should be ordered.«

Ordering (continuous)
AVP-F Controller (return mounting)

Picture	DN (mm)	k_{vs} (m ³ /h)	Connection	Δp sett. range (bar)	Code No.	Δp sett. range (bar)	Code No.	Δp sett. range (bar)	Code No.	
	15	1.6	Cylindr. ext. thread acc. to ISO 228/1	0.2	003H6218	0.3	003H6224	0.5	003H6230	
		2.5			003H6219		003H6225		003H6231	
		4.0			003H6220		003H6226		003H6232	
	20	6.3			003H6221		003H6227		003H6233	
		25			8.0		003H6222		003H6228	003H6234
					10		-		003H6229	-

Note: other controllers available on request.

Accessories

Picture	Type designation	DN	Connection	Code No.
	Weld-on tailpieces	15	-	003H6908
		20		003H6909
		25		003H6910
		32		003H6911
	External thread tailpieces	15	Conical ext. thread acc. to EN 10226-1	R 1/2 003H6902
		20		R 3/4 003H6903
		25		R 1 003H6904
		32		R 1 1/4 003H6905
	Flange tailpieces	15	Flanges PN 25, acc. to EN 1092-2	003H6915
		20		003H6916
		25		003H6917
	Impulse tube set AV	Description: - 1x copper tube $\varnothing 6 \times 1 \times 1500$ mm - 1x compression fitting ^{*)} for imp. tube connection to pipe $\varnothing 6 \times 1$ mm	R 1/8 003H6852	
			R 3/8 003H6853	
			R 1/2 003H6854	
	* 10 compression fittings for imp. tube connection to pipe, $\varnothing 6 \times 1$ mm R 1/8	003H6857		
	* 10 compression fittings for imp. tube connection to pipe, $\varnothing 6 \times 1$ mm R 3/8	003H6858		
	* 10 compression fittings for imp. tube connection to pipe, $\varnothing 6 \times 1$ mm R 1/2	003H6859		
	* 10 compression fittings for imp. tube connection to actuator, $\varnothing 6 \times 1$ mm G 1/8	003H6931		
	Shut off valve $\varnothing 6$ mm	003H0276		

^{*)} Compression fitting consists of a nipple, compression ring and nut.

Service kits

Picture	Type designation	DN	k_{vs} (m ³ /h)	Code No.	
				AVP(-F) return	AVP(-F) flow
	Valve insert	15	0.4	-	003H6869
			1.0	-	003H6870
			1.6	003H6863	003H6871
			2.5	003H6864	003H6872
			4.0	003H6865	003H6873
		20	6.3	003H6866	003H6874
		25	8.0	003H6867	003H6875
32	10				
	Actuator with adjustable handle (AVP)	Δp setting range (bar)	0.05 - 0.5	003H6821	003H6823
			0.2 - 1.0	003H6822	003H6824
			0.8 - 1.6		
	Actuator without adjustable handle (AVP-F)	Δp setting range (bar)	0.2	003H6825	-
			0.3		
			0.5		

Technical data

Valve

Nominal diameter		DN	15				20	25	32	
k _{vs} value		m ³ /h	0.4	1.0	1.6	2.5	4.0	6.3	8.0	10
Cavitation factor z ¹⁾			≥ 0,6							
Nominal pressure		PN	25							
Max. differential pressure		bar	12							
Medium			Circulation water / glycolic water up to 30%							
Medium pH			Min. 7, Max. 10							
Medium temperature		°C	2...150							
Connections		valve	Ext. thread							
		tailpieces	Weld-on and external thread							
			Flange							-
Materials										
Valve body			Red bronze CuSn5ZnPb (Rg5)							
Valve seat			Stainless steel, mat. No. 1.4571							
Valve cone			Dezincing free brass CuZn36Pb2As							
Sealing			EPDM							

¹⁾ k_v/k_{vs} ≤ 0.5 at DN 25 and higher

Actuator

Type		AVP			AVP-F			
Actuator size		cm ²	39					
Nominal pressure		PN	16					
Diff. pressure setting ranges and spring colours		bar	0.05 - 0.5	0.2 - 1.0	0.8 - 1.6	0.2	0.3	0.5
			grey	black	(fixed setting)			
Materials								
Actuator housing			Zinc chromatic steel, DIN 1624, No. 1.0338					
Diaphragm			EPDM					
Impulse tube			Copper tube Ø 6 x 1 mm					

Application principles

- Return mounting

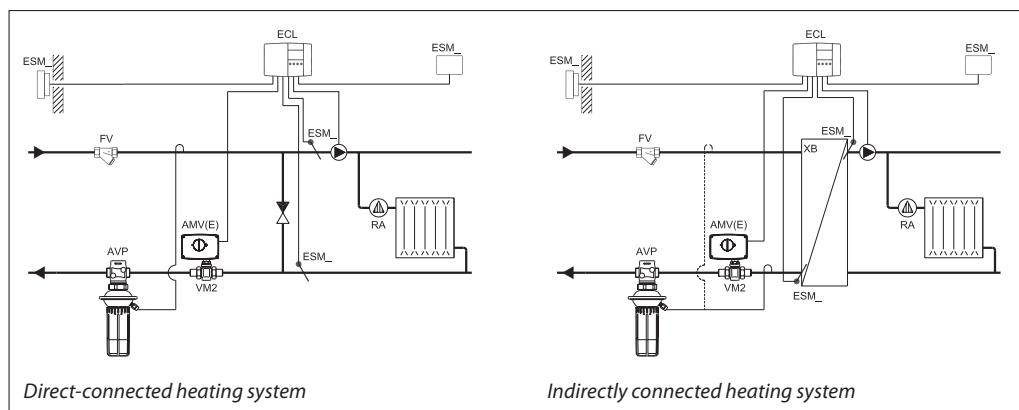

- Flow mounting

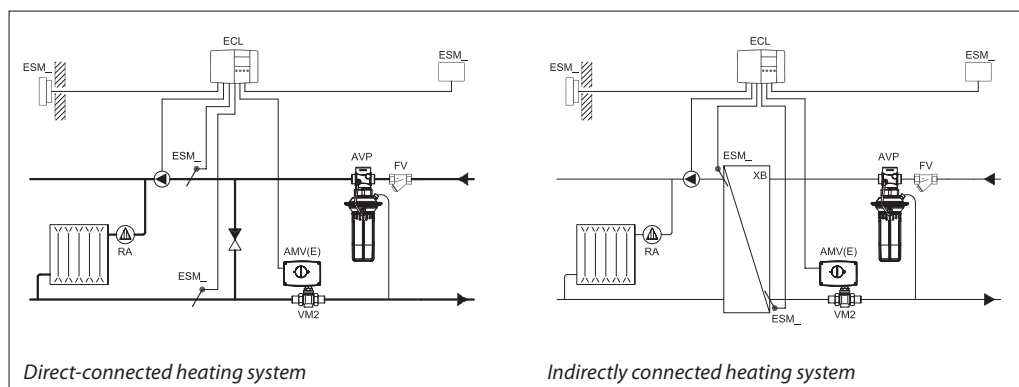

Installation positions

Up to medium temperature of 100 °C the controllers can be installed in any position.

For higher temperatures the controllers have to be installed in horizontal pipes only, with a pressure actuator oriented downwards.

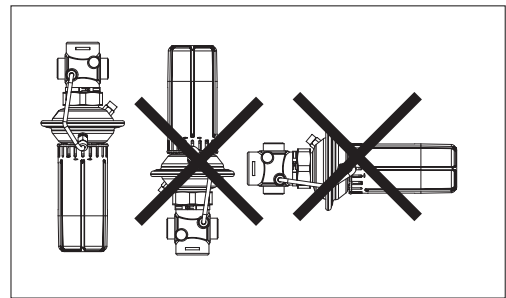
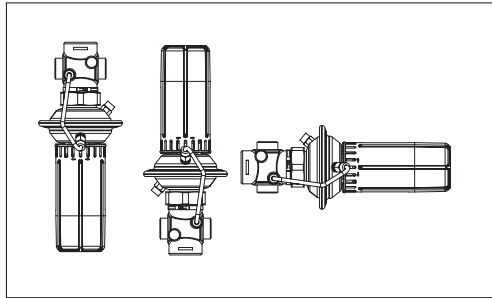

Pressure temperature diagram

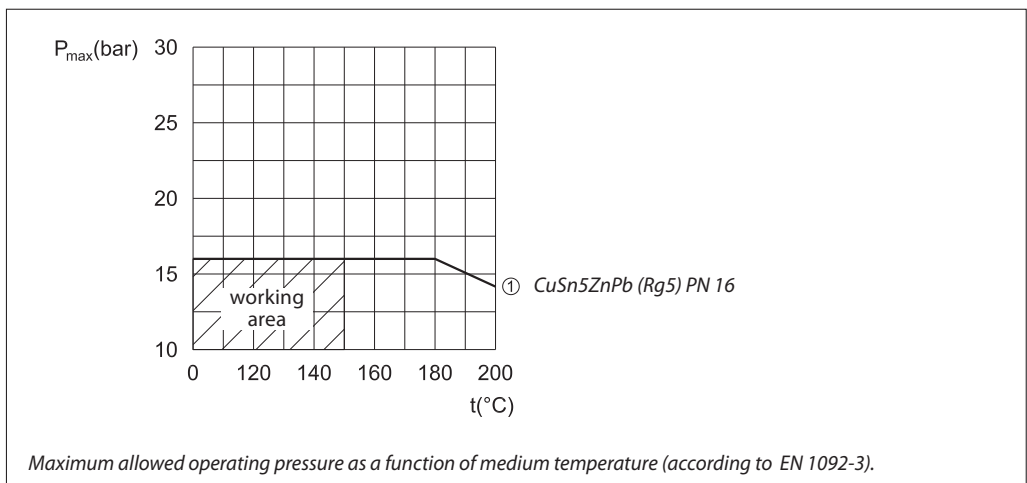

Sizing

- Directly connected heating system

Example 1

Motorised control valve (MCV) for mixing circuit in direct-connected heating system requires differential pressure of 0.2 bar (20 kPa).

Given data:

- Q_{max} = 1.3 m³/h (1300 l/h)
- Δp_{min} = 0.7 bar (70 kPa)
- * $\Delta p_{circuit}$ = 0.1 bar (10 kPa)
- Δp_{MCV} = 0.2 bar (20 kPa) selected

*Remark

$\Delta p_{circuit}$ corresponds to the required pump pressure in the heating circuit and is not to be considered when sizing the AVP

The differential pressure set value is:

$$\Delta p_{set\ value} = \Delta p_{MCV}$$

$$\Delta p_{set\ value} = 0.2\ bar\ (20\ kPa)$$

The total pressure loss across the controller is:

$$\Delta p_{AVP} = \Delta p_{min} - \Delta p_{MCV} = 0.7 - 0.2$$

$$\Delta p_{AVP} = 0.5\ bar\ (50\ kPa)$$

Possible pipe pressure losses in tubes, shut-off fittings, heatmeters, etc. are not included.

k_v value is calculated according to formula:

$$k_v = \frac{Q_{max}}{\sqrt{\Delta p_{AVP}}} = \frac{1.3}{\sqrt{0.5}}$$

$$k_v = 1.8\ m^3/h$$

or read from the sizing diagram, page 7, by taking a line from Q-scale (1.3 m³/h) through Δp_v -scale (0.5 bar) to intersect k_v -scale at 1.8 m³/h.

Solution:

The example selects AVP DN 15, k_{vs} value 2.5, with differential pressure setting range 0.05 - 0.5 bar.

The P-band (Xp) can also be read from the sizing diagram. Take a horizontal line from the k_v -scale (1.8 m³/h) to the right to intersect the X_p -scale (0.04 bar). At a set value of 0.2 bar and a X_p of 0.04 bar the AVP controller controls between 0.2 bar with open motorised control valve and 0.2 + 0.04 = 0.24 bar at almost closed motorised control valve (i.e. total pressure loss across the motorised control valve).

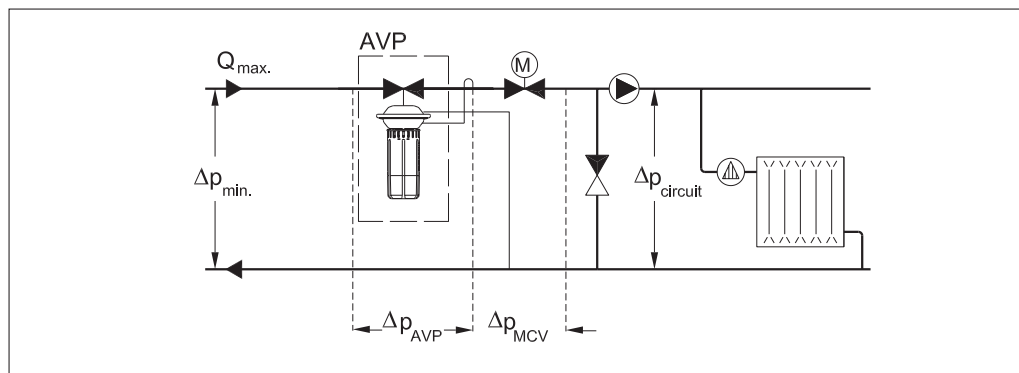
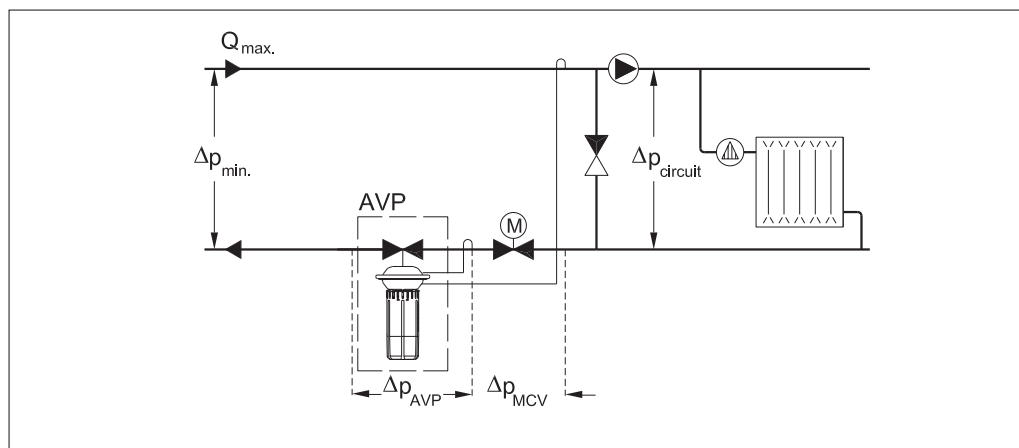

Sizing (continuous)

- Indirectly connected heating system

Example 2

Motorised control valve (MCV) for indirectly connected heating system requires differential pressure of 0.3 (30 kPa) bar.

Given data:

- Q_{max} = 0.8 m³/h (800 l/h)
- Δp_{min} = 0.8 bar (80 kPa)
- $\Delta p_{exchanger}$ = 0.05 bar (5 kPa)
- Δp_{MCV} = 0.3 bar (30 kPa) selected

The differential pressure set value is:

$$\Delta p_{set\ value} = \Delta p_{exchanger} + \Delta p_{MCV} = 0.05 + 0.3$$

$$\Delta p_{set\ value} = 0.35\ \text{bar (35 kPa)}$$

The total pressure loss across the controller is:

$$\begin{aligned} \Delta p_{AVP} &= \Delta p_{min} - \Delta p_{exchanger} - \Delta p_{MCV} \\ &= 0.8 - 0.05 - 0.3 \end{aligned}$$

$$\Delta p_{AVP} = 0.45\ \text{bar (45 kPa)}$$

Possible pipe pressure losses in tubes, shut-off fittings, heatmeters, etc. are not included.

k_v value is calculated according to formula:

$$k_v = \frac{Q_{max}}{\sqrt{\Delta p_{AVP}}} = \frac{0.8}{\sqrt{0.45}}$$

$$k_v = 1.2\ \text{m}^3/\text{h}$$

or read from the sizing diagram, page 7, by taking a line from Q -scale (0.8 m³/h) through Δp_v -scale (0.45 bar) to intersect k_v -scale at 1.2 m³/h.

Solution:

The example selects AVP DN 15, k_{vs} value 1.6, with differential pressure setting range 0.05 - 0.5 bar.

The P-band (X_p) can also be read from the sizing diagram. Take a horizontal line from the k_v -scale (1.2 m³/h) to the right to intersect the X_p -scale (0.04 bar). At a set value of 0.35 bar and a X_p of 0.04 bar the AVP controller controls between 0.35 bar with open motorised control valve and $0.35 + 0.04 = 0.39$ bar at almost closed motorised control valve (i.e. total pressure loss across the motorised control valve).

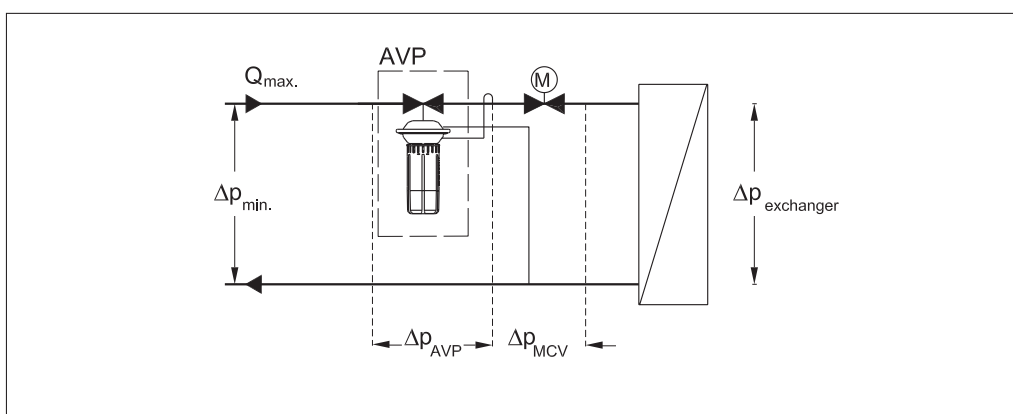
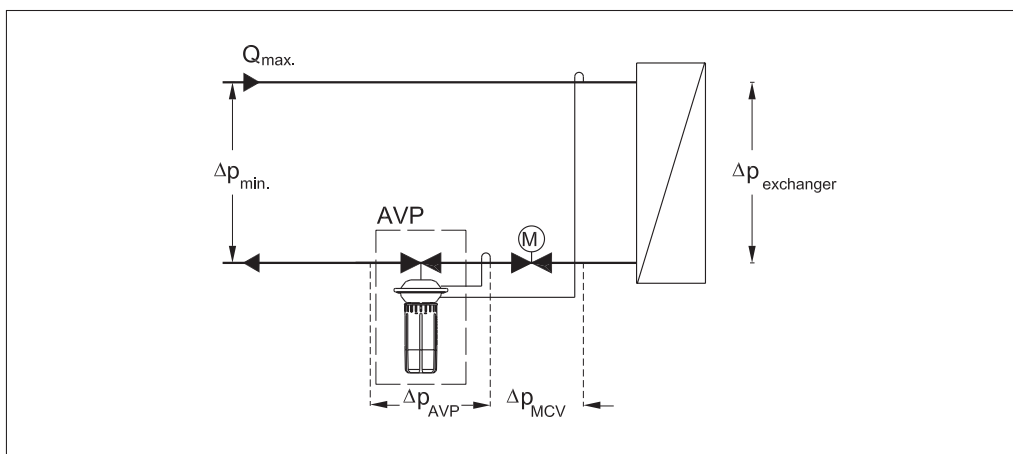

Sizing (continuous)

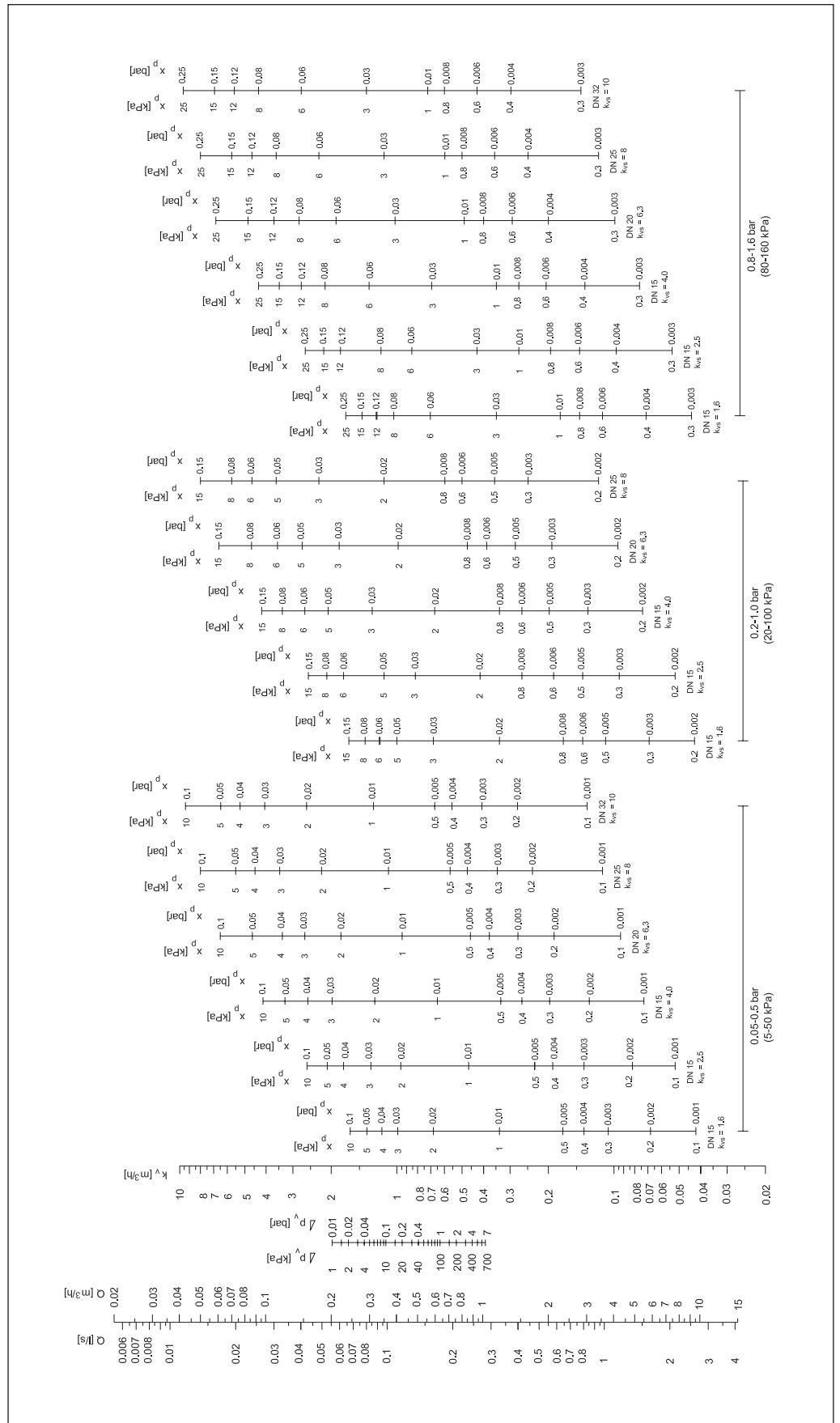

Select suitable controller size. Xp should not exceed 50% of the controller differential pressure setting.

Design

- 1. Valve body
- 2. Valve insert
- 3. Pressure relieved valve cone
- 4. Valve stem
- 5. Control drain
- 6. Actuator
- 7. Control diaphragm
- 8. Setting spring for diff. pressure control
- 9. Handle for diff. pressure setting, prepared for sealing
- 10. Union nut
- 11. Compression fitting for impulse tube

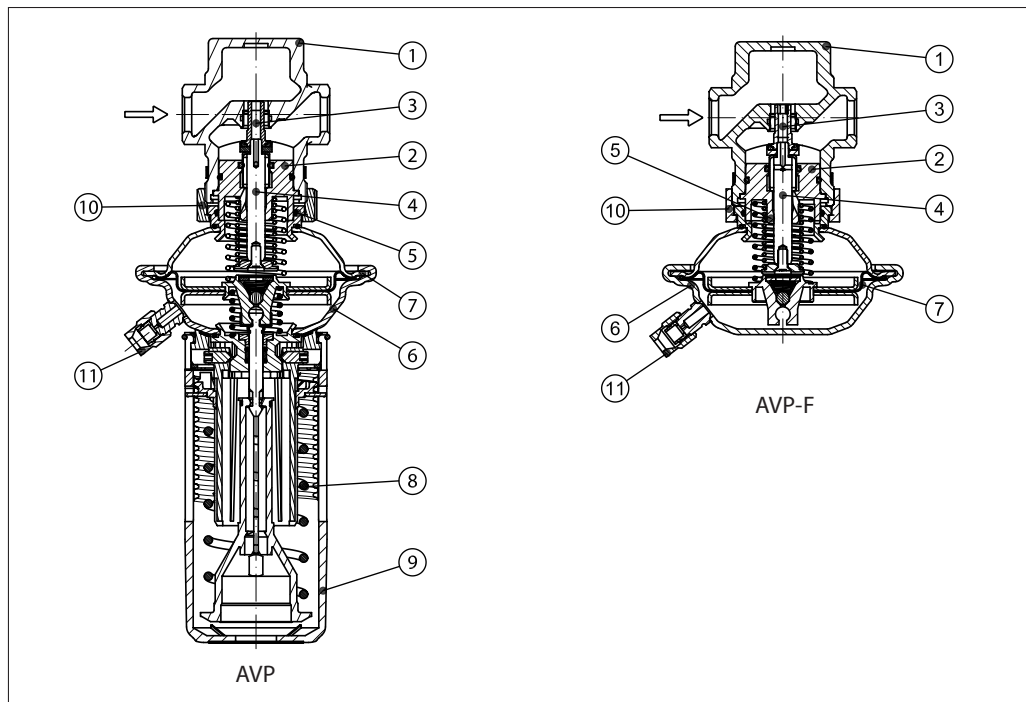

Function

Pressure changes from the flow and return pipeline are being transferred through the impulse tubes and/or control drain in the actuator stem to the actuator chambers and act on control diaphragm. Control valve closes on rising differential pressure and opens on falling differential pressure to maintain constant differential pressure.

Controller is equipped with excess pressure safety valve, which protects actuator from too high differential pressure.

Settings

Differential pressure setting
 Differential pressure setting is being done by the adjustment of the setting spring for diff. pressure control. The adjustment can be performed on the basis of diff. pressure adjustment diagram (see relevant instructions) and/or pressure indicators.

Adjustment

Relation between scale figures and differential pressure. Values given are approximate.

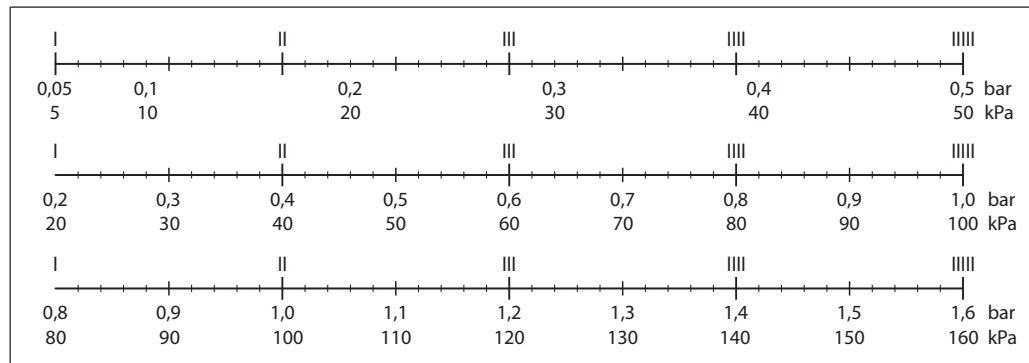

Dimensions

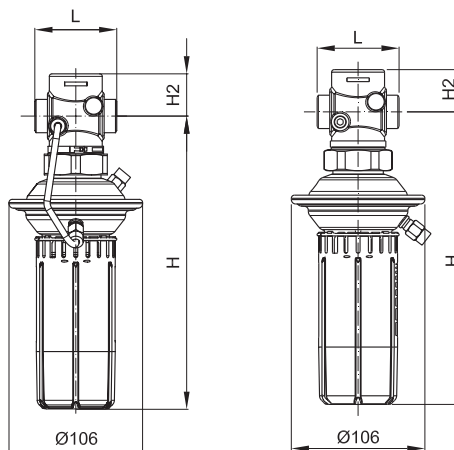

AVP

DN	15		20		25		32	
	flow	return	flow	return	flow	return	flow	return
L	65		70		75		100	
H	232		232		232		232	
H2	34		34		38		38	
Weight	1.7		1.8		1.9		2.2	

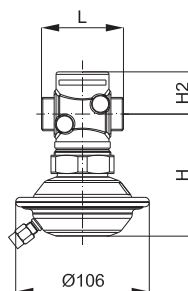

AVP-F (return)

DN	15	20	25	32
L	65	70	75	100
H	97	97	97	97
H2	34	34	38	38
Weight	1.3	1.4	1.5	1.8

Dimensions (continuous)

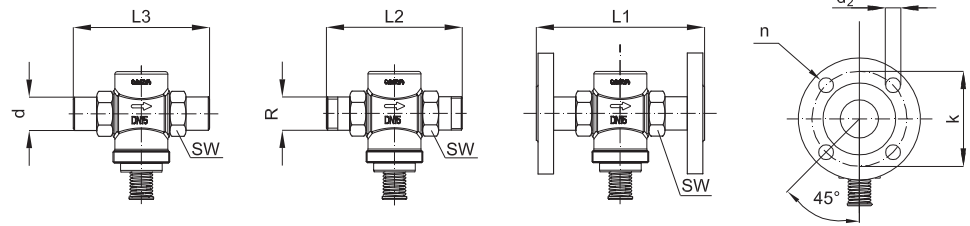

DN		15	20	25	32
SW		32 (G 3/4A)	41 (G 1A)	50 (G 1 1/4A)	63 (G 1 3/4A)
d		21	26	33	42
R ¹⁾		1/2	3/4	1	1 1/4
L1 ²⁾	mm	130	150	160	-
L2		131	144	160	177
L3		139	154	159	184
k		65	75	85	-
d ₂		14	14	14	-
n		4	4	4	-

¹⁾ Conical ext. thread acc. to EN 10226-1

²⁾ Flanges PN 25, acc. to EN 1092-2

Compression fittings

