

DRYTEC
A Mikropor Company

COMPRESSED
AIR SYSTEMS
PRODUCT CATALOG



DRYTEC
A Mikropor Company

01	COMPANY INTRODUCTION	06
02	FILTRATION AND SEPARATION	08
03	COMPRESSED AIR DRYERS	36
04	GAS TREATMENT AND GAS GENERATION	58



OUR COMPANY



With over 37 years of experience in compressed air systems, Drytec is one of the leading companies in compressed air filters and automatic drainage systems.

Founded in Angleur, Belgium, Drytec offers compressed air products and services world wide with more than 200 dealerships globally, Drytec is favored in the sector and is trusted due to the company's extensive experience in compressed air products including Air Dryers.

Consistently adapting itself to new developments in technology and rapidly integrating solutions needed by the sector into its structure, Drytec carries on its operations with expertise.

Known for its expertise in the Compressed Air Systems, Drytec has joined forces with world-renowned Mikropor and moved its operations under the same roof as Mikropor in 2019.

02

FILTRATION AND SEPARATION

AIR FILTERS	10
AIR INTAKE FILTERS	12
AIR/OIL SEPARATORS	16
AIR FILTER ELEMENTS	18
REPLACEMENT ELEMENTS	20
WATER SEPARATORS	21
FLANGED COMPRESSED WATER SEPARATORS	22
G SERIES COMPRESSED AIR FILTERS	24
GO SERIES COMPRESSED AIR FILTERS	26
FLANGED COMPRESSED AIR FILTERS	30
MIST ELIMINATOR COMPRESSED AIR FILTERS	32
HIGH PRESSURE COMPRESSED AIR FILTERS	34



FILTRATION AND
SEPARATION

Air Filters for Air Compressors

Drytec Air Filters are the first line of defence for any air compressor and have a significant impact on the service life of the compressor, lubricant, air/oil separators and oil filters.

Drytec offers the highest efficiency air intake filters in the market, outperforming the competition and delivering more value to customers.

Micro-Glass and Mini-Pleat System in Air Filters

Our Micro-Glass Mini-Pleated Air Filters reach a 99.99% efficiency faster than cellulose air filters and provide better protection by allowing fewer contaminants to pass through the media.

Drytec Nano Media holds up to five times more contaminants than conventional cellulose air filters, making them ideal for extended maintenance periods.



Equal Space System



Micro-Glass Fiber at x500 Magnification



Cellulose Fiber at x500 Magnification

Drytec Micro-Glass fibers are very fine nano scale fibers and are eighty times smaller in diameter than cellulose fiber. This results in extremely high initial efficiency and protects the air compressor better than any filter available in the market.

The Drytec Mini-Pleat system guarantees equal space between each filter pleat and maintains "V" pleated geometry throughout the service life of the filter. As a result, 100% of the surface area performs equally and delivers the expected protection, while minimizing pressure drops.



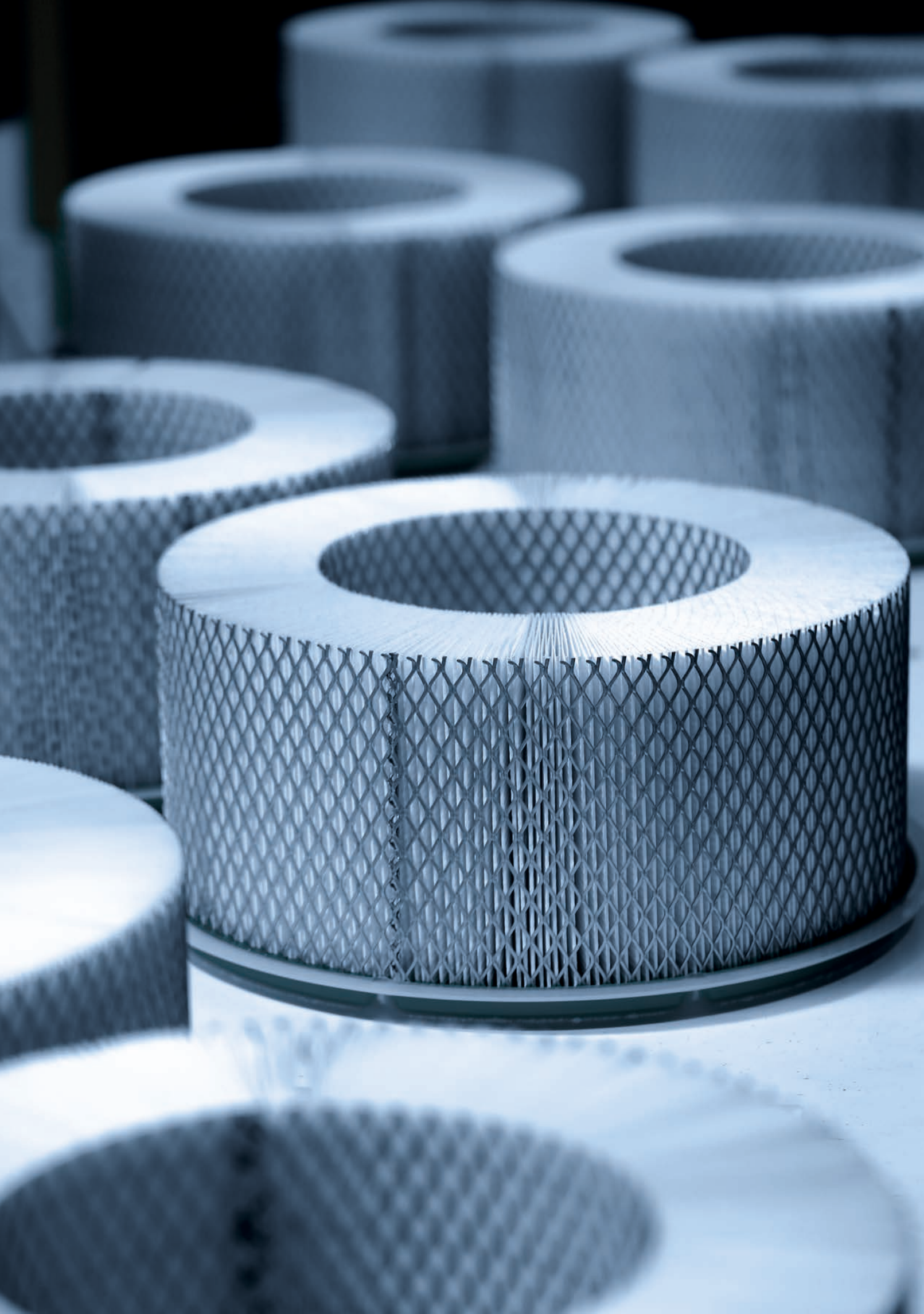

Drytec's air intake elements are designed for the removal of dust or particulate in the air intake systems of compressors, machines, pumps, blowers, etc. Based on the density of the dust load, Drytec offers two series with different sizes and capacities:

Mikroline and Makroline.

Applications

Mikroline Air Intake Filters are well suited for applications with low dust loads such as power generators, piston compressors, as well as air cleaner ventilation of gear units and the filtration of liquid tanks.

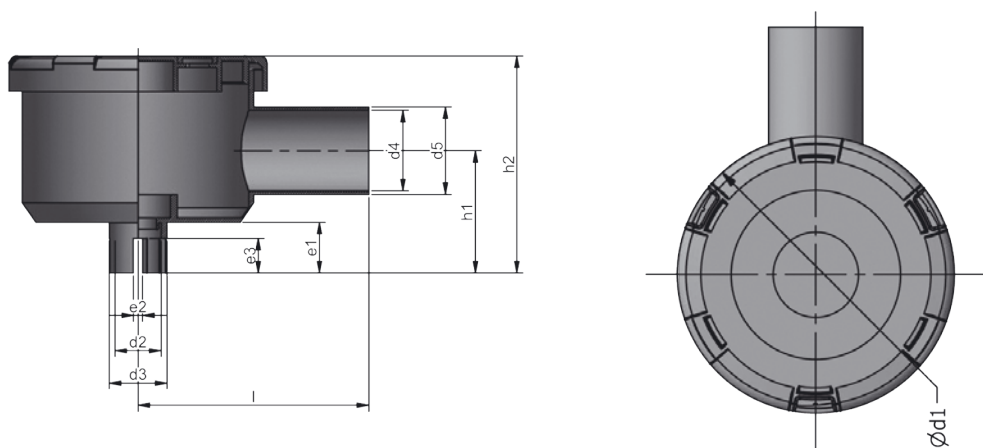

General Working Conditions

Type	Overall Design	Volumetric Flow Range (m ³ /min)	Continuous Operating Temperature	Short Time Maximum Operating Temperature
Mikroline Air Intake Filters	Highly Reliable Plastic Air Cleaner Housing with High Quality Element	1 m ³ /min to 4 m ³ /min	-30°C to +100°C	+120°C

Dimensions

Model	d1	d2	d3	d4	d5	e1	e2	e3	e4	h1	h2	l	Nominal Flow Rate (m ³ /min)	Compressor Connection Type
MIFH-0120	112	20	25	35	38	22	4	15	-	53	94	100	1	Internal Tightened
MIFH-0130	112	30	35	35	38	22	4	15	-	53	94	100	1	Internal Tightened
MIFH-0140	112	40	45	35	38	22	4	15	-	53	94	100	1	Internal Tightened
MIFH-0240	140	40	45	35	38	22	4	15	-	67	114	120	2	Internal Tightened
MIFH-0252	140	52	57	35	38	22	16.25	15	8.125	67	114	120	2	Internal Tightened
MIFH-0260	140	60	65	35	38	22	4	15	-	67	114	120	2	Internal Tightened
MIFH-0271	140	71	76	35	38	22	4	15	-	67	114	120	2	Internal Tightened
MIFH-0452	181	52	57	58	60	22	16.25	15	8.125	102	164	154.5	4	Internal Tightened
MIFH-0460	181	60	65	58	60	22	4	15	-	102	164	154.5	4	Internal Tightened
MIFH-0471	181	71	76	58	60	22	4	15	-	102	164	154.5	4	Internal Tightened

Note: Measure unit is mm

Design

Drytec Makroline Air Intake Filters are designed to provide maximum performance for customers with extremely high dust capacity and low pressure drop air intake filter demands. Makroline filters are also suitable for use in higher temperature environments.

Applications

Drytec Makroline Air Intake Filters are designed for medium and heavy dust load conditions for applications such as Air Compressors, Construction Machines, Agricultural Machines, Harvesting Machines, etc.

Advantages

The advantages of Makroline Air Intake Filters are:

- Operational reliability,
- Long service life thanks to its highly efficient and reliable filter elements,
- Low pressure drop,
- Impact resistant corrosion free housing polypropylene,
- Excellent price/performance ratio.

Drytec Makroline Air Intake Filters’ user friendly and flexible bracket system provides the ability for easy installation. The brackets can be turned in various positions, providing numerous fitting possibilities. Drytec’s versatile production offers these brackets in different sizes.



Easy and various mounting possibilities

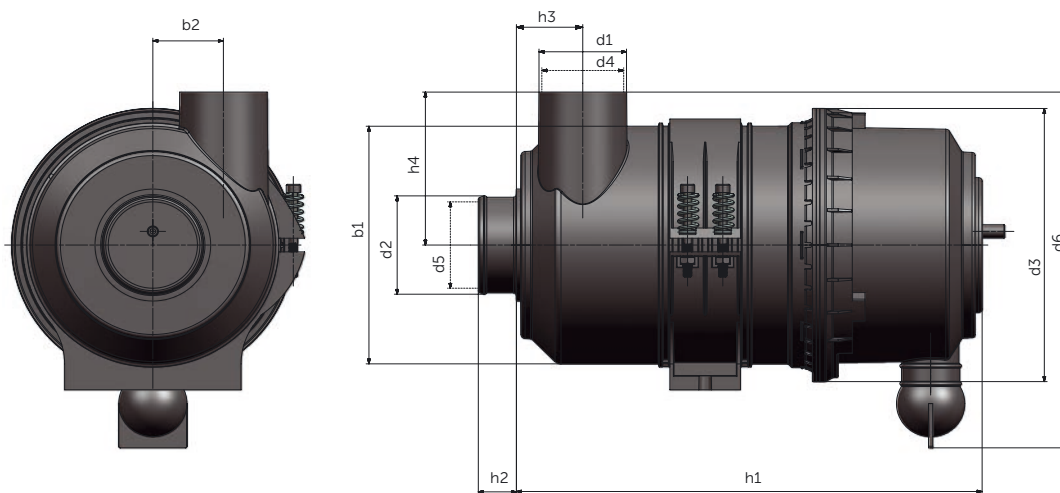

General Working Conditions for Makroline Air Intake Filters

Type	Overall Design	Volumetric Flow Range (m³/min)	Continuous Operating Temperature	Short Time Maximum Operating Temperature
Makroline Air Intake Filters	Highly Reliable Plastic Air Cleaner Housing with High Quality Element Center Tube in Housing Radial Seal	3 m³/min to 28 m³/min	-30°C to +80°C	+100°C

Technical Specifications

Model	b1	b2	d1	d2	d3	d4	d5	d6	h1	h2	h3	h4	Nominal Flow Rate (m³/min)	Compressor Connection Type
MAFH-02030	164	48	55	30	185	52	23	245	263	27	43	103	1-3	External Clamped
MAFH-02040	164	48	55	40	185	52	33	245	263	27	43	103	1-3	External Clamped
MAFH-02050	164	48	55	50	185	52	43	245	263	27	43	103	1-3	External Clamped
MAFH-05040	179	50	62	40	200	58	34	260	330	27	47	112	2-5	External Clamped
MAFH-05050	179	50	62	50	200	58	44	260	330	27	47	112	2-5	External Clamped
MAFH-05060	179	50	62	60	200	58	54	260	330	27	47	112	2-5	External Clamped
MAFH-05070	179	50	62	70	200	58	63	260	330	27	47	112	2-5	External Clamped
MAFH-0350	142	45	52	50	160	49	47	209	292	26	56	94	3-4	External Clamped
MAFH-0360	142	45	52	60	160	49	57	209	292	26	56	94	3-4	External Clamped
MAFH-09070	230	67	82	70	251	78	63	320	388	27	55	145	4-9	External Clamped
MAFH-09090	230	67	82	90	251	78	83	320	263	27	43	103	4-9	External Clamped
MAFH-09100	230	67	82	100	251	78	93	320	263	27	43	103	4-9	External Clamped
MAFH-0870	200	53	94	70	226	89	64	293	263	27	43	103	8-10	External Clamped
MAFH-08100	200	53	94	100	226	89	94	293	330	27	47	112	8-10	External Clamped
MAFH-1270	200	53	94	70	227	89	64	293	330	27	47	112	12-14	External Clamped
MAFH-12100	200	53	94	100	227	89	94	293	330	27	47	112	12-14	External Clamped
MAFH-17100	297	86.5	110	100	323	104	93	399.5	330	27	47	112	17	External Clamped
MAFH-17110	297	86.5	110	110	323	104	103	399.5	292	26	56	94	17	External Clamped
MAFH-17130	297	86.5	110	130	323	104	123	399.5	292	26	56	94	17	External Clamped
MAFH-18100	322	90	132	100	352	127	95	432	413	34	79	212	18	External Clamped
MAFH-18110	322	90	132	110	352	127	105	432	413	34	79	212	18	External Clamped
MAFH-18130	322	90	132	130	352	127	125	432	413	34	79	212	18	External Clamped
MAFH-18150	322	90	132	150	352	127	145	432	413	34	79	212	20	External Clamped
MAFH-20100	322	90	132	100	352	127	95	432	443	34	79	212	20	External Clamped
MAFH-20110	322	90	132	110	352	127	105	432	443	34	79	212	20	External Clamped
MAFH-20130	322	90	132	130	352	127	125	432	443	34	79	212	22	External Clamped
MAFH-22100	322	90	132	100	352	127	95	432	473	34	79	212	22	External Clamped
MAFH-22110	322	90	132	110	352	127	105	432	473	34	79	212	22	External Clamped
MAFH-22130	322	90	132	130	352	127	125	432	473	34	79	212	24	External Clamped
MAFH-24100	322	90	132	100	352	127	95	432	503	34	79	212	24	External Clamped
MAFH-24110	322	90	132	110	352	127	105	432	503	34	79	212	24	External Clamped
MAFH-24130	322	90	132	130	352	127	125	432	503	34	79	212	26	External Clamped
MAFH-26100	322	90	132	100	352	127	95	432	533	34	79	212	26	External Clamped
MAFH-26110	322	90	132	110	352	127	105	432	533	34	79	212	26	External Clamped
MAFH-26130	322	90	132	130	352	127	125	432	533	34	79	212	28	External Clamped
MAFH-28100	322	90	132	100	352	127	95	432	563	34	79	212	28	External Clamped
MAFH-28100	322	90	132	110	352	127	105	432	563	34	79	212	28	External Clamped
MAFH-28130	322	90	132	130	352	127	125	432	563	34	79	212	28	External Clamped

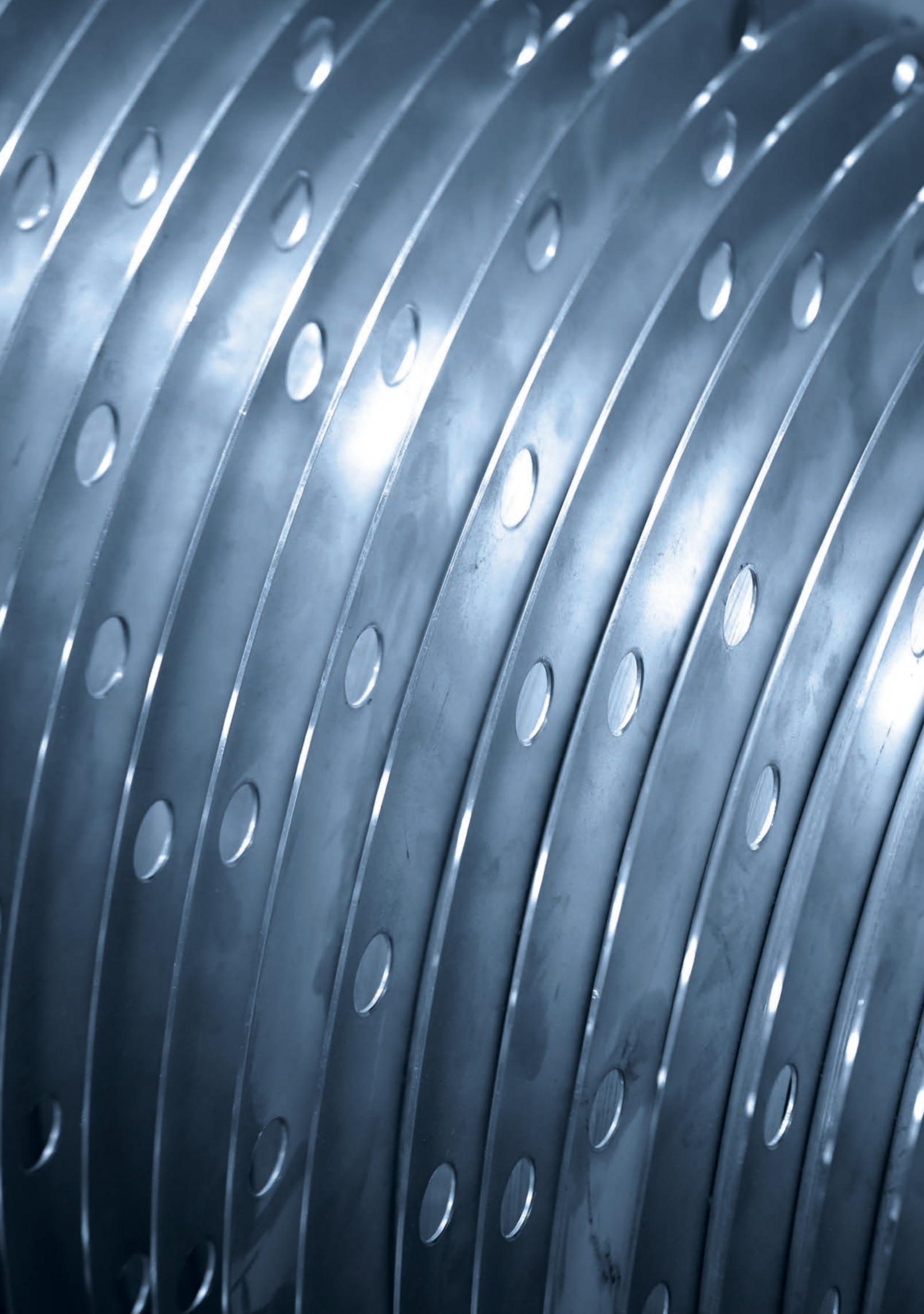

Why Drytec Separators?

With over 3000 Air/Oil Separator designs for compressors, Drytec offers multiple options for the full range of air flow and performance requirements.

Drytec Air/Oil Separators

Conventional, pleated, depth construction, spin-on and state-of-the-art "sep-n-sep" design separators allow Drytec to cover the air/oil separation needs of the entire compressor applications.



Air Flow Rates of Drytec Air/Oil Separators (m³/min @ 7 bar working pressure)

Dimensions

Air/Oil Separator Overall Height (mm)

		150	200	250	300	350	400	450	500	550	600	650	700	750	800	850	900	950	1000		
Air/Oil Separator Body Diameter (mm)	110	Conventional	1	2	2																
	3S	3	5	5																	
		Sep-n-Sep®																			
		135	Conventional	2	2	3	3	4	5												
		3S	4	5	6	8	8	9													
		Sep-n-Sep®																			
		150	Conventional	2	2.5	3	4	5	5	6	7										
		3S	4	5	7	8	10	11	12	13											
		Sep-n-Sep®																			
		170	Conventional	2	3	4	5	5	6	7	8	9	9								
		3S	4	6	8	10	11.5	13	14	16	17	19									
		Sep-n-Sep®																			
		200	Conventional		3	5	5	7	7	8	9	10	11	12							
		3S		7	9	11	13	15	17	19	21	23	25								
		Sep-n-Sep®																			
		220	Conventional			5	6	7	8	9	11	12	13	14	15	16					
		3S			10	13	15	17	19	22	23	26	28	30	33						
		Sep-n-Sep®																			
		270	Conventional			7	8	9	10	12	13	15	16	17	19	20	22	23	24		
		3S			14	15	18	21	24	27	29	32	35	38	41	44	47	49			
	Sep-n-Sep®			21	23	27	31	36	40	44	48	52	56	61	66	70	73				
	300	Conventional			8	9	10	12	13	15	17	18	20	21	23	24	26	28	29	31	
	3S			15	18	21	24	27	30	34	37	40	43	46	49	53	57				
	Sep-n-Sep®			24	28	32	37	41	46	53	57	62	66	71	76	82	88				
	350	Conventional			10	12	14	16	18	20	22	24	26	28	30	32	34	36	38		
	3S			20	24	28	32	36	40	44	48	52	56	60							
	Sep-n-Sep®			32	38	44	50	56	63	69	75	81	88	94							
	375	Conventional			11	13	15	17	19	21	23	25	27	29	32	33	35	37	39		
	3S			22	26	30	34	38	42	46	50	54	58								
	Sep-n-Sep®			34	40	47	54	60	66	72	79	85	91								
	400	Conventional				15	17	19	21	23	25	27	29	32	34	36	38	40	42		
	3S					30	34	37	42	46	51	55	59								
	Sep-n-Sep®				47	52	59	67	73	81	88	94									
	470	Conventional					20	22	25	27	30	33	35	37	41	43	45	48	51		
	3S						40	45	50	55											
	Sep-n-Sep®					63	71	79	87												
	500	Conventional						24	27	30	33	36	39	42	45	48	51	54	56		
	3S							50	55	60											
	Sep-n-Sep®							82	91	100											

Conwrap Separators

Drytec "Conwrap" Separators are standard wrapped style separators. These separators are designed for outside to inside flow and can be used with all oil injection Rotary Vane and Rotary Screw Compressors. Conwrap separators operate between 1 to 60 m³/min flow rate at 7 bar with 1 to 3 mg/m³ oil carry over.

"3S" Depth Construction Air/Oil Separators

The revolutionary Drytec "3S" Separator is designed to fit the smaller separator housings without sacrificing operating performance. The "3S" separator has double to triple capacity when compared to a conventional separator with the same dimensions. The "3S" separator has 1/2 - 1/3 of the volume of a conventional separator functioning in the same operating conditions. This increased capacity is achieved with specially designed progressive type, deep bed, coalescing media using an increased number of wraps.

Pleated Air/Oil Separators

Pleated separators increase the media surface area to reach higher capacities while maintaining the dimensions. Drytec manufactures dozens of pleated separator designs.



CONWRAP



3S - SEPARATORS



PLEATED

Zero Spin-On Type Air/Oil Separators

Drytec Spin-On Type Air/Oil Separators are manufactured as exchangeable elements. Because Spin-Ons do not require a compressor housing, they permit uncomplicated and quick replacement without dismantling the compressor. Spin-On Type Air/Oil Separators are available for 0,5 to 7 m³/min flow rates operating at 7 bar.

Model	Maximum Flow Rate (m ³ /min @ 7 bar)	Dia 1 (mm)	Dia 2 (mm)	Height (mm)
Zero 10	0,5	Ø79	Ø80	84
Zero 20	1	Ø79	Ø83	137
Zero 30	2	Ø97	Ø100	214
Zero 40	1.5	Ø97	Ø100	175
Zero 50	4	Ø110	Ø111	261
Zero 60	3	Ø138	Ø141	192
Zero 70	6	Ø138	Ø141	314
Zero 80	7	Ø138	Ø141	349

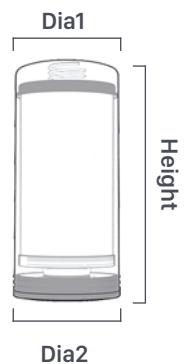

Micro-Glass Fiber

High efficiency Micro-Glass nanofiber media (80 times finer than Cellulose Fiber) delivers higher targeted efficiencies, longer service life, wide chemical and synthetic lubricant compatibility even at extreme working temperatures.

Element 4 Levels

Drytec offers four layers of Superior Protection-from 1 micron to 0.01 micron. Durable element construction and an efficient drain layer ensure continued performance with optimal element change periods.

Helix Tubes for Strength

Drytec Compressed Air Filters have louvered stainless steel helix tubes providing increased strength and protection against severe pressure drops while improving performance by forcing air to pass diagonally through the element.

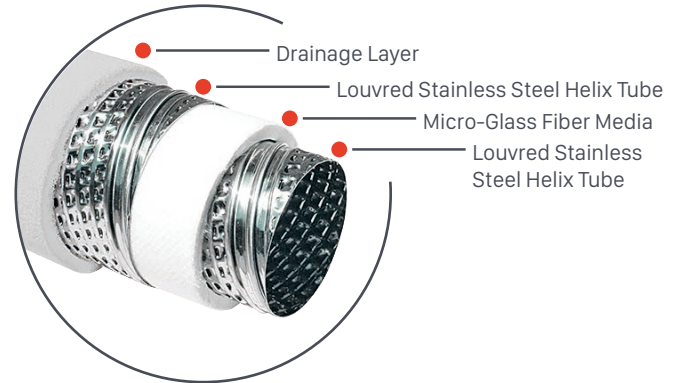

Synthetic Compatibility and Durable Epoxy

Drytec Compressed Air Filters are compatible with all synthetic lubricants in the industry. Durable Epoxy securely bonds the robust end caps to the filter tubes and will not be affected by the synthetic lubricant in compressed air.



Test

With over 30 years of experience Drytec manufactures the best performing replacement elements in the industry. Through rigorous testing and validation processes

Drytec assures that the replacement elements perform equal to or better than the original elements.

Replacement elements have been designed and tested in our state-of-the-art test laboratories.

Drytec labs are capable of making the following tests;

- Differential pressure at given flow rates
- Particle efficiency tests
- Oil aerosols measurements
- Pressure dew point

All tests are conducted as per the relevant ISO 12500 test standards.



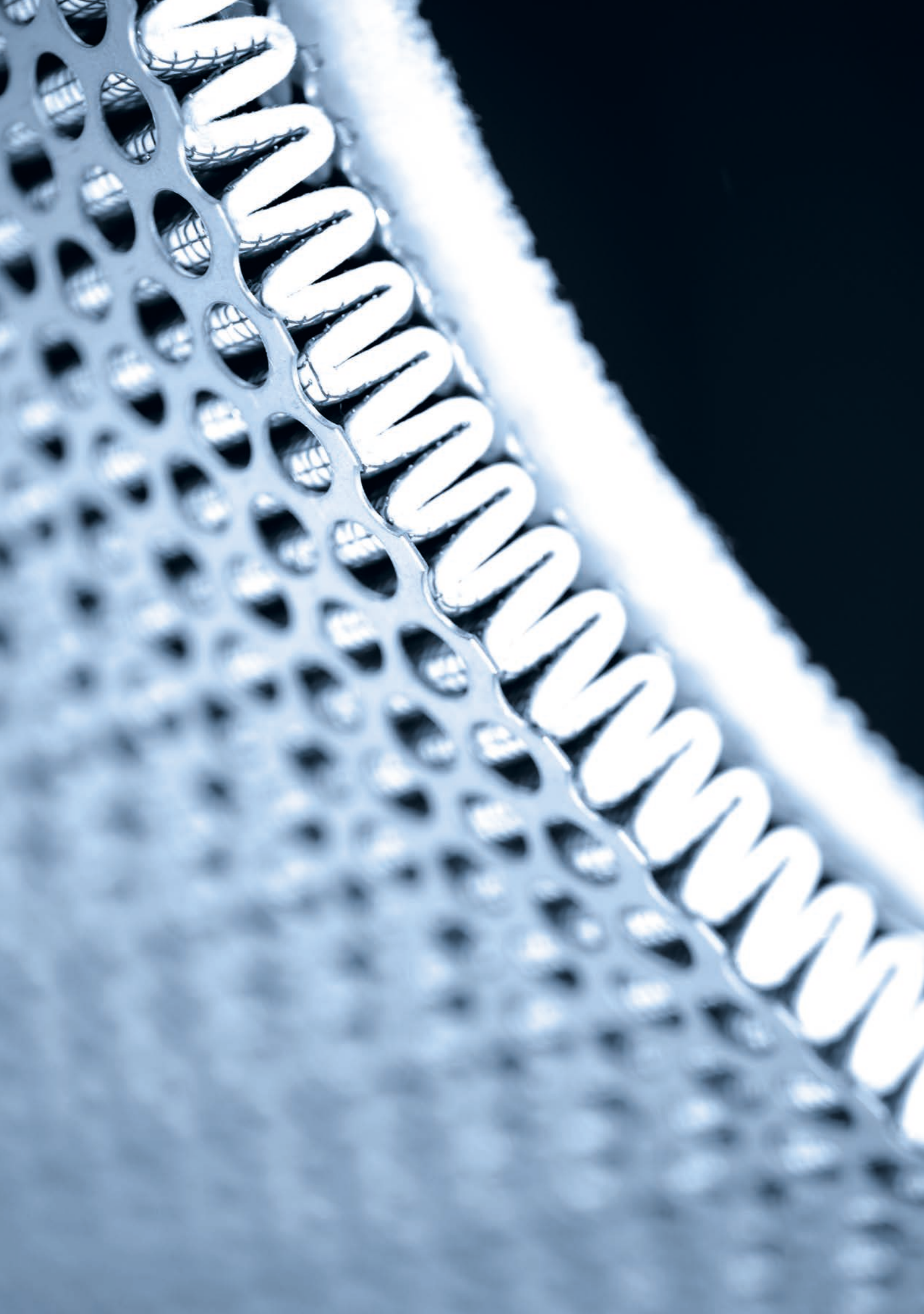



- ALMIG
- ATLAS COPCO
- BEA
- COMPAIR
- DELTECH
- DOMNICK HUNTER
- DOMNICK HUNTER (Evolution Range)
- FAI FILTER
- HANKISON
- HIROSS
- KAESER
- MTA
- OMI
- ULTRA FILTER
- WALKER
- ZANDER



Drytec water separators have been designed for the removal of bulk liquid water and particulate from compressed air and gases. Unique centrifugal action removes contaminants at low-pressure drop for maximum energy saving.

Drytec water separators are available from 1/4"-3" pipe sizes and for flows up to 2200 m³/h (1294 cfm).

Note: While highly efficient, condensate separators will not remove 100% of the oil from the air stream. Additional coalescing and particulate filters downstream may be required to remove the fine traces of oil, water and particles.

Note: Automatic drain valves are fitted as standard. All separator bodies are coated with electrostatic powder paint finish both inside and out.

Correction Factor

For maximum flow rate, multiply model flow rate show in the above table by the correction factor corresponding to the working pressure.

Operating Pressure (bar)	Psi	Correction Factor
1	15	0.5
3	44	0.71
5	73	0.87
7	100	1
9	131	1.12
11	160	1.22
13	189	1.32
15	218	1.44
16	247	1.57



Technical Specifications

For maximum flow rate, multiply model flow rate show in the above table by the correction factor corresponding to the working pressure.

Model	Connection Size	Flow Rate		Housing Dimensions (mm)			
		(m ³ /h)	(cfm)	A	B	C	D
G25WS	1/4"	25	14	103	257.5	236	160
G100WS	1/2"	100	58	103	257.5	236	210
G200WS	3/4"	200	117	123	304	277	285
G300WS	1"	300	176	123	304	277	380
G600WS	1 1/2"	600	353	123	320	285	470
G1200WS	2"	1200	706	160	484	443	560
G2200WS	3"	2200	1294	193	546	490	610

Max. Recommended Operating Temperature	Min. Recommended Operating Temperature	Typical Pressure Loss at Rated Flow	Max. Working Pressure
80°C	1.5°C	50 mbar	16 bar

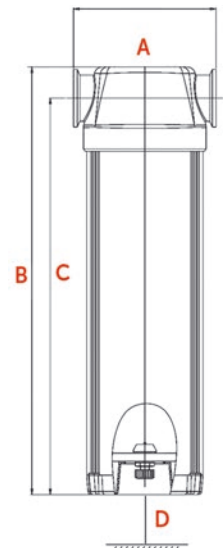

FLANGED COMPRESSED WATER SEPARATORS

Drytec flanged water separators have been designed for the removal of bulk liquid water and particulate from compressed air and gases. Unique centrifugal action removes contaminants at low-pressure drop for maximum energy savings. Drytec flanged water separators are available from DN80-DN200 flange sizes and flows up to 14000 m³/h (8236 cfm) **(For larger sizes please contact our sales team).**

Note: While highly efficient, condensate separators will not remove all of the oil from the air stream. Additional coalescing and particulate filters downstream may be required to remove the fine traces of oil, water and particles.

Correction Factor

For maximum flow rates, multiply model flow rate show in the above table by the correction factor corresponding to the working pressure.

Operating Pressure (bar)	PSI	Correction Factor
1	15	0.5
3	44	0.71
5	73	0.87
7	100	1
9	131	1.12
11	160	1.22
13	189	1.32
14	200	1.38

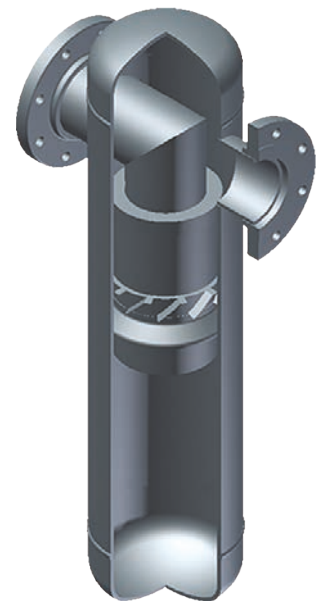
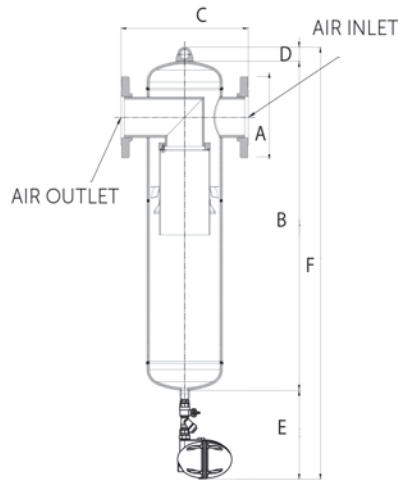

Max. Recommended Operating Temperature	Min. Recommended Operating Temperature	Typical Pressure Loss at Rated Flow	Max. Working Pressure
80°C	15°C	50 mbar	14 bar

Technical Specifications

Model	Connection Size	Flow Rate		Housing Dimensions (mm)					
		(m ³ /h)	(cfm)	A	B	C	D	E	F
F-2500WS	DN80	2500	1407.5	200	934	450	75	280	1289
F-3200WS	DN100	3200	1882.3	220	964	450	75	280	1319
F-4300WS	DN100	4300	2529.4	220	982	530	75	280	1283
F-6500WS	DN150	6500	3823.5	285	1092	580	75	280	1447
F-8500WS	DN150	8500	5000	285	1091	650	75	280	1446
F-11000WS	DN200	11000	6470.5	340	1168	750	75	280	1523
F-14000WS	DN200	14000	8235.2	340	1201	800	75	280	1556



G SERIES COMPRESSED AIR FILTERS

Drytec Compressed Air Filters have been designed to meet all requirements of the compressed air filtration world. These air filters provide more comfortable usage for end users with an increased endurance, higher efficiency at lower pressure drop and more port size options.

Filtration

Due to our usage of deep pleating technique, the filtration area is significantly increased remarkably, which leads to a better filtration and higher dirt holding capacity. Drytec Compressed Air Filters have been designed to remove air borne contamination in compressed air stream, delivering energy efficient operation and reliable performance.

Features

The air filters have four efficiency ratings, removing contaminants as small 0.01 micron at up to 290 psi (20 bar)- 1/4" to 3" NPT/BSP pipe sizes. A protected auto float drain (2 mm orifice) is standard for optimal and reliable removal of liquid contaminants.

These air filters have a zero-porosity aluminium and durable epoxy powder-coat finish, along with a corrosion-resistant internal coating for a long service life. Filter combinations are configured to meet specific application requirements. Filters comply with PED and perform as per related ISO 8573 standards. These filters may be equipped with differential pressure gauges for easy maintenance and energy efficiency.

Drytec compressed air filters are always recommended with this system.

Types of Compressed Air Filters

- P** Pre-Filter / Particulate Filter
(Filter/Element air flow direction is outside to inside)
- X** General Purpose Filter / Water Removal
(Filter/Element air flow direction is inside to outside)

- Y** Coalescing Filter / Oil Removal
(Filter/Element air flow direction is inside to outside)
- A** Activated Carbon Filter / Odor Removal
(Filter/Element air flow direction is outside to inside)



Correction Factor

For maximum flow rate, multiply model flow rate show in the above table by the correction factor corresponding to the working pressure.

Operating Pressure (bar)	PSI	Correction Factor
1	15	0.5
3	44	0.71
5	73	0.87
7	100	1
9	131	1.12
11	160	1.22
13	189	1.32
15	218	1.44
16	232	1.50
18	261	1.57
20	290	1.63

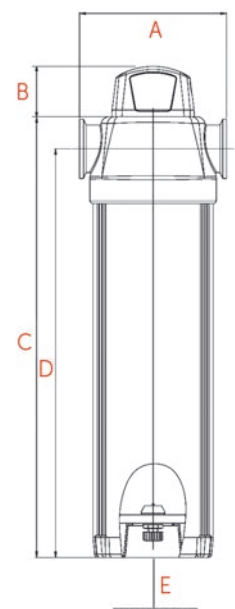

G SERIES COMPRESSED AIR FILTERS

Technical Specifications

Model	Connection Size	Flow Rate		Max. Working Pressure (bar)	Element Model	Housing Dimensions (mm)				
		(m ³ /h)	(cfm)			A	B	C	D	E
G20	1/4"	20	12	20	M20	75	45	193	175	100
G40	3/8"	40	24	20	M40	75	45	193	175	100
G25	1/4"	25	15	20	M25	102	45	219.5	197.5	125
G50	3/8"	50	30	20	M50	102	45	219.5	197.5	125
G100	1/2"	100	58	20	M100	102	45	257.5	235.5	165
G150	3/4"	150	88	20	M150	123	45	302.5	275.5	205
G200	3/4"	200	117	20	M200	123	45	366.5	339.5	265
G250	1"	250	147	20	M250	123	45	406.5	379.5	315
G300	1 1/4"	300	176	20	M300	123	45	463	427.5	365
G500	1 1/4"	500	294	20	M500	123	45	493	457.5	395
G600	1 1/2"	600	353	20	M600	123	45	538	502.5	440
G851	2"	851	500	20	M851	160	45	625.5	583.8	495
G1210	2"	1210	712	20	M1210	160	45	695.5	653.8	565
G1520	2 1/2"	1520	930	20	M1520	194	45	730	672	445
G1820	3"	1820	1140	20	M1820	194	45	870	813	565
G2220	3"	2220	1380	20	M2220	194	45	924	867	615
G2620	3"	2620	1541	20	M2620	194	45	1068	1011	695

Specifications	Pre Filtering	General Purpose	Oil Removal	Activated Carbon	Indicator Type
Grade	P	X	Y	A	Gauge with or without electrical contact
Particle Removal (Micron)	5	1	0.01	0.01	Drain Type
Max. Oil Carryover at 21°C (mg/m ³)	5	0.5	0.01	0.003	
Max. Working Temperature (°C)	80	80	80	25	External Float Type
Initial Pressure Loss (mbar)	40	80	100	80	Zero-loss Drain
Pressure Loss for Element Change (mbar)	700	700	700	700	Manual
Element Color Code	White	White	White	Metal SS	

Notes

- Grade A must not operate in oil saturated conditions.
- Grade A elements should be replaced periodically to suit the applications but must be changed at least every six months.
- Grade A will not remove certain gases including carbon monoxide and carbon dioxide. Please refer to works if in doubt.
- Flow rates are based on a 7 bar operating pressure, for flows at other pressures use correction factor given above.
- All filters are suitable for use with mineral and synthetic oils.
- Gauge type pressure indicators are fitted to models G20 to G2620 as standard.
- All filters are in conformity with the Pressure Equipment Directive (97/23/EC).

Ordering

The complete filter model number contains the size and grade, example - 1" general purpose filter model G250MX with replacement filter element model M250X. 250 Represent 250 m³/h capacity and X represents the general purpose element.

GO SERIES COMPRESSED AIR FILTERS

FILTRATION AND SEPARATION

New addition to our G series, Drytec GO series compressed air filters are designed for easy element replacement for "zero clearance" ability.

Features

The air filters have four efficiency ratings, removing contaminants as small as 0.01 micron at up to 290 psi (20 bar) - 1/4" to 3" NPT/BSP pipe sizes. A protected auto float drain (2 mm orifice) is standard for optimal and reliable removal of liquid contaminants.

These air filters have zero-porosity aluminium and durable epoxy powder-coat finish, along with a corrosion resistant internal coating for a long service life.

Filter combinations are configured to meet specific application requirements. Filters comply with PED and perform as per related ISO 8573 standards.

These filters may be equipped with differential pressure gauges for easy maintenance and energy efficiency. Drytec compressed air filters are always recommended with this system.

Element Features

Drytec offers Superior protection - from 1 micron to 0,01 micron. Durable element construction and efficient drain layer ensures continued performance with optimal element change intervals. Elements are also easy to replace with the head clips.

Drytec Elements Have Been Designed for Easy Handling

- 1- Deep pleating also enables a lower pressure drop.
- 2- Supreme collapse resistance due to usage of fluted stainless tube, providing strength against pressure drops while improving the performance by passing air diagonally through the element.
- 3- PVC impregnated foam favors water/oil drainage.

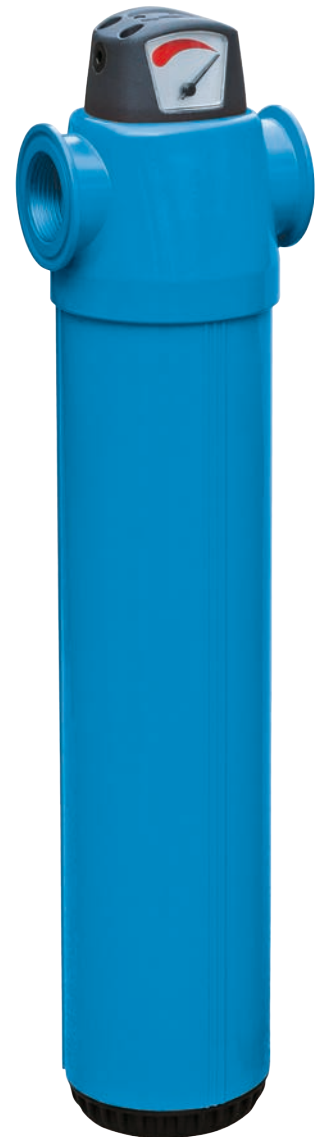

GO SERIES COMPRESSED AIR FILTERS

Head Clamping

Head Clamping provides serial connection of filters without any extra piping

Drainage Ribs

Drainage Ribs favors the humidity flow

Correction Factor

For maximum flow rate, multiply model flow rate show in the above table by the correction factor corresponding to the working pressure.

Operating Pressure (bar)	PSI	Correction Factor
1	15	0.5
3	44	0.71
5	73	0.87
7	100	1
9	131	1.12
11	160	1.22
13	189	1.32
15	218	1.44
16	232	1.50
18	261	1.57
20	290	1.63

Zero Clearance

A major innovation for servicing the zero clearance design gives a quicker, easier, simpler filter change, with no need for any specialist tools.

Anodising

Anodising provides supreme corrosion resistance. Anodised surface treatment is proven to be better than other surface treatment methods such as Alocrome coating. Contact Drytec to get Comparison Test results between competitor filters with Alocrome coating and Drytec Filters with Anodising treatment.



Independent Test Report as Per ISO 12500-1

Filter element:		M50Y	
Element		002	
Standard parameters and measuring results			
Measuring parameters	unit	standard	Test
Calendar date of test			
			28./29.09.10
Inlet temperature	°C	20 ± 5	18,5 ± 0,5
Inlet pressure	bar (e)	7	7
Ambient temperature	°C	20 ± 5	17,5 ± 0,5
Inlet dew point	°C	≤ 10 °C	0 - 4
Main flow through the test filter			50
Partial flow	m³/h		5,1
Time of conditioning	h		20,38
Measuring time	h		2,75
Inlet oil concentration at conditioning	mg/m³		23 ± 1
Inlet oil concentration at test	mg/m³	10 ± 10%	10 ± 1
Residual oil concentration	mg/m³		0,01
Pressure drop filter element	mbar		183
Remarks			mouth of probe oil-free
Test carried out by			
Signature			

Drytec M50Y-2 at 50 m³/h ANR - 7 bar(e)
28.-29.09.10

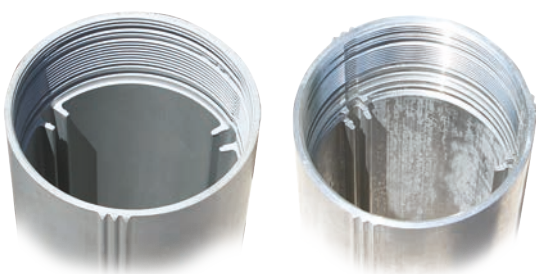
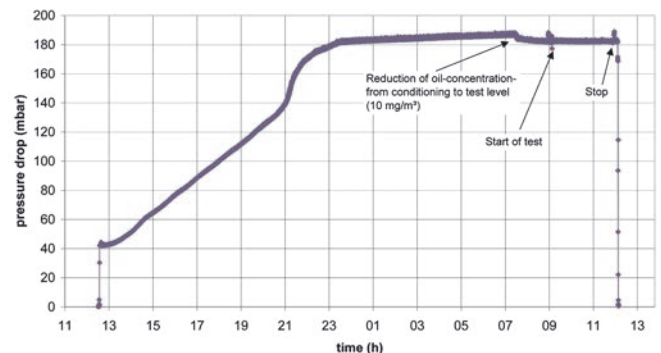

With Anodising

Without Anodising

GO SERIES COMPRESSED AIR FILTERS

Technical Specifications

Model	Connection Size	Flow Rate		Max. Working Pressure (bar)	Element Model	Housing Dimensions (mm)				
		(m ³ /h)	(cfm)			A	B	C	D	E
GO20	1/4"	20	12	20	MO20	75	45	193	175	7
GO40	3/8"	40	24	20	MO40	75	45	193	175	7
GO25	3/8"	25	15	20	MO25	102	45	214.5	192.5	7
GO50	3/8"	50	30	20	MO50	102	45	214.5	192.5	7
GO100	1/2"	100	58	20	MO100	102	45	252.5	230.5	7
GO150	3/4"	150	88	20	MO150	123	45	297.5	270.5	8
GO200	3/4"	200	117	20	MO200	123	45	361.5	334.5	8
GO250	1"	250	147	20	MO250	123	45	401.5	374.5	8
GO300	1 1/4"	300	176	20	MO300	123	45	458	422.5	8
GO500	1 1/4"	500	294	20	MO500	123	45	488	452.5	8
GO600	1 1/2"	600	353	20	MO600	123	45	533	497.5	9
GO851	2"	851	500	20	MO851	160	45	622.5	581	9
GO1210	2"	1210	712	20	MO1210	160	45	692.5	651	9
GO1520	2 1/2"	1520	930	20	MO1520	194	45	725.5	669	10
GO1820	3"	1820	1140	20	MO1820	194	45	865	808	10
GO2220	3"	2220	1380	20	MO2220	194	45	919.5	863	11
GO2700	3"	2700	1541	20	MO2700	194	45	1063.5	1007	11

Specifications	Pre Filtering	General Purpose	Oil Removal	Activated Carbon	Indicator Type
Grade	P	X	Y	A	Gauge with or without electrical contact
Particle Removal (Micron)	5	1	0.01	0.01	Drain Type
Max. Oil Carryover at 21°C (mg/m ³)	5	0.5	0.01	0.003	
Max. Working Temperature (°C)	80	80	80	25	External Float Type
Initial Pressure Loss (mbar)	40	80	100	80	Zero-Loss Drain
Pressure Loss for Element Change (mbar)	700	700	700	700	Manual
Element Color Mode	White	White	White	Metal SS	

Notes

- Grade A must not operate in oil saturated conditions.
- Grade A elements should be replaced periodically to suit the applications but must be changed at least every six months.
- Grade A will not remove certain gases including carbon monoxide and carbon dioxide. Please refer to works if in doubt.
- Flow rates are based on a 7 bar operating pressure, for flows at other pressures use correction factor given above.
- All filters are suitable for use with mineral and synthetic oils.
- Gauge type pressure indicators are fitted to models GO25 to GO2700 as standard.
- All filters are in conformity with the Pressure Equipment Directive (97/23/EC).

Ordering

The complete filter model number contains the size and grade, example - 1" general purpose filter model GO250MX with replacement filter element model MO250X. 250 Represent 250 m³/h capacity and X represents the general purpose element.



FLANGED COMPRESSED AIR FILTERS

Features

- Elements are assembled with a tie rod system
- Two external float drains for maximum drainage
- Unique design for pre-separation zone
- Strong welded design
- CE and ASME tanks available
- Design for easy element change from top flange

External Float Drain

Drytec external drain is designed to remove liquid condensation from collection points in a Compressed Air System.

Durable epoxy powder-coat finish and corrosion resistant internal anodised coating for longer service life.

Correction Factor

For maximum flow rate, multiply model flow rate show in the above table by the correction factor corresponding to the working pressure.

Operating Pressure (bar)	PSI	Correction Factor
1	15	0.5
3	44	0.71
5	73	0.87
7	100	1
9	131	1.12
11	160	1.22
13	189	1.32
14	200	1.38

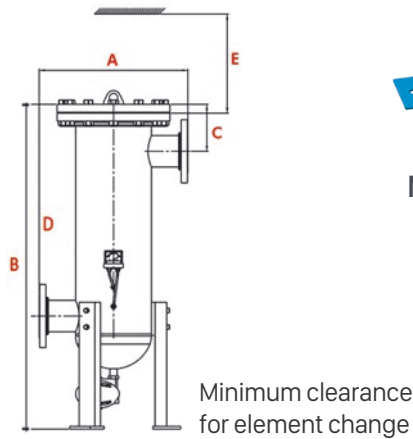

Minimum clearance for element change

High Performance Elements Inside

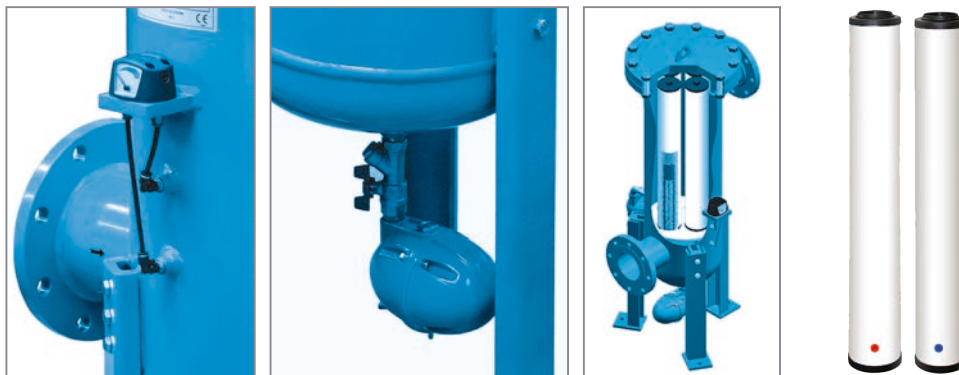

Technical Specifications

Model	Drain Port Size	Inlet/Outlet Port Size	Flow Rate		Max. Working Pressure (bar)	Element Model	Number of Elements	Housing Dimensions (mm)				
			(m ³ /h)	(cfm)				A	B	C	D	E
F2500	1/2"	DN80	2500	1470	14	M1200	2	450	1287	277	747	650
F3200	1/2"	DN100	3200	1880	14	M1200	3	450	1317	277	767	650
F4300	1/2"	DN100	4300	2530	14	M1200	4	530	1344	279	769	650
F6500	1/2"	DN150	6500	3825	14	M1200	6	580	1425	331	796	650
F8500	1/2"	DN150	8500	5000	14	M1200	8	650	1439	333	798	650
F11000	1/2"	DN200	11000	6470	14	M1200	10	750	1504	365	825	650
F14000	1/2"	DN200	14000	8235	14	M1200	14	800	1545	383	833	650
F17000	1/2"	DN250	17000	10000	14	M1200	16	850	1583	417	862	650
F21000	1/2"	DN300	21000	12350	14	M1200	17	850	1680	447	887	650
F25500	1/2"	DN350	25500	15000	14	M1200	23	850	1778	487	917	650
F30000	1/2"	DN350	30000	17650	14	M1200	28	850	1778	487	917	650

Specifications	Pre Filtering	General Purpose	Oil Removal	Activated Carbon	Drain Type
Grade	P	X	Y	A	Electro - Adjustable
Particle Removal (Micron)	5	1	0.01	0.01	External Float Type
Max. Oil Carryover at 21°C (mg/m ³)	5	0.5	0.01	0.003	Zero-loss Drain
Max. Working Temperature (°C)	80	80	80	25	Manual
Initial Pressure Loss (mbar)	40	80	100	80	
Pressure Loss for Element Change (mbar)	700	700	700	700	
Element Color Mode	White	White	White	Metal SS	

Notes

- 1) Grade A must not operate in oil saturated conditions.
- 2) Grade A elements should be replaced periodically to suit the applications but must be changed at least every six months.
- 3) Grade A will not remove certain gases including carbon monoxide and carbon dioxide. Please refer to works if in doubt.
- 4) Flow rates are based on a 7 bar operating pressure, for flows at other pressures use correction factor given above.
- 5) All filters are suitable for use with mineral and synthetic oils.
- 6) Other standards for flanged connections are available.
- 7) Direction of air flow is inside to out, through filter element.

Ordering

The complete filter model number contains the size and grade, Example - pipe size NW100 oil removal filter with model filter F3200MY replacement filter element model M1200Y.

MIST ELIMINATOR COMPRESSED AIR FILTERS

- Ultra low pressure drop reduces energy costs
- Positive gasket seals eliminate media bypass
- Filter change out differential 170 mbar (2.5 psi)
- True Air/Oil Separator
- Long service life

Applications Include

- Capturing oil fog, mist, or smoke from exhaust and pressure unloading vents on oil flooded compressors, vacuum pumps and blowers
- Any application requiring Low Delta P coalescing of large air volumes
- Vacuum Freeze Drying
- Vacuum Out-Gassing and Vacuum Coating
- Food Processing
- Nailers/Staplers
- Industrial Vacuum Processes
- Cement & Paper Processing Design

Design

Mist Eliminators are designed to meet the demand for:

- Efficient removal of oil-mist carryover from piston or oil flooded rotary compressors
- Long service life
- Strength to withstand strenuous operating conditions
- Protection from oil slugs or compressor Air/Oil separator failure

Features

- Very low pressure drop
- Large oil catching efficiency
- Easy field cleaning
- Positive sealing O-rings
- Temperature (continuous) 4°C (40°F) min. 80°C (176°F) max.
- Auto Float Drain is standard
- Multiple drain style options available
- Pressure rating of 14 bar (200 psi)
- Removal of particles down to 0.01 micron including coalesced liquid water and oil, providing a maximum remaining oil aerosol content of 0.01 ppm
- Increased surface area in a given volume allows low velocity separation of ultra fine oil mist
- Elements are grounded to canister, minimizing static electricity problems

Correction Factor

For maximum flow rate, multiply model flow rate show in the above table by the correction factor corresponding to the working pressure.

Drain Type
Electro - Adjustable
External Float Type
Zero-loss Drain
Manual

FILTRATION AND SEPARATION

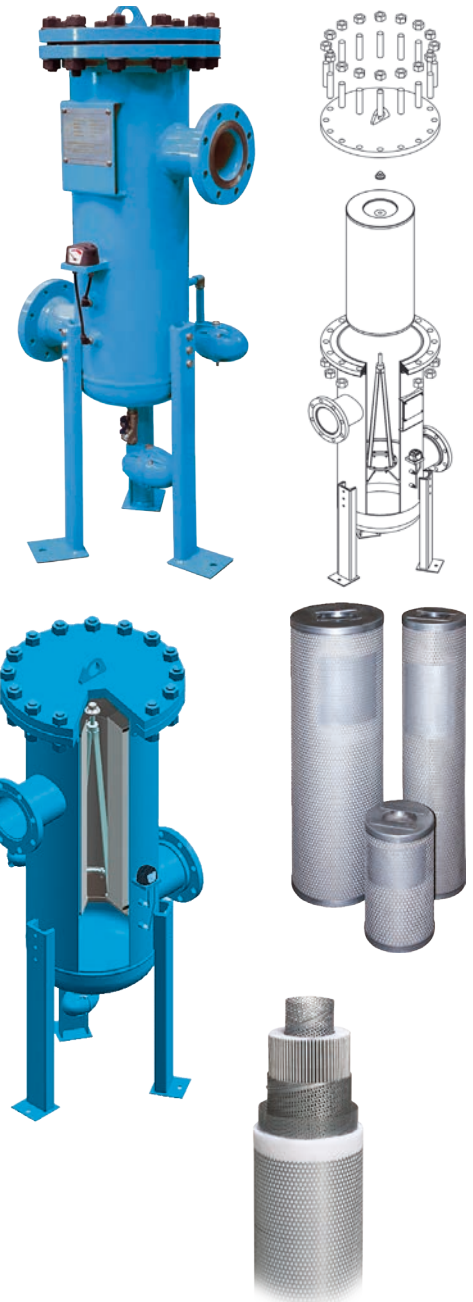

Operating Pressure (bar)	PSI	Correction Factor
1	15	0.5
3	44	0.71
5	73	0.87
7	100	1
9	131	1.12
11	160	1.22
13	189	1.32
14	200	1.38

MIST ELIMINATOR COMPRESSED AIR FILTERS

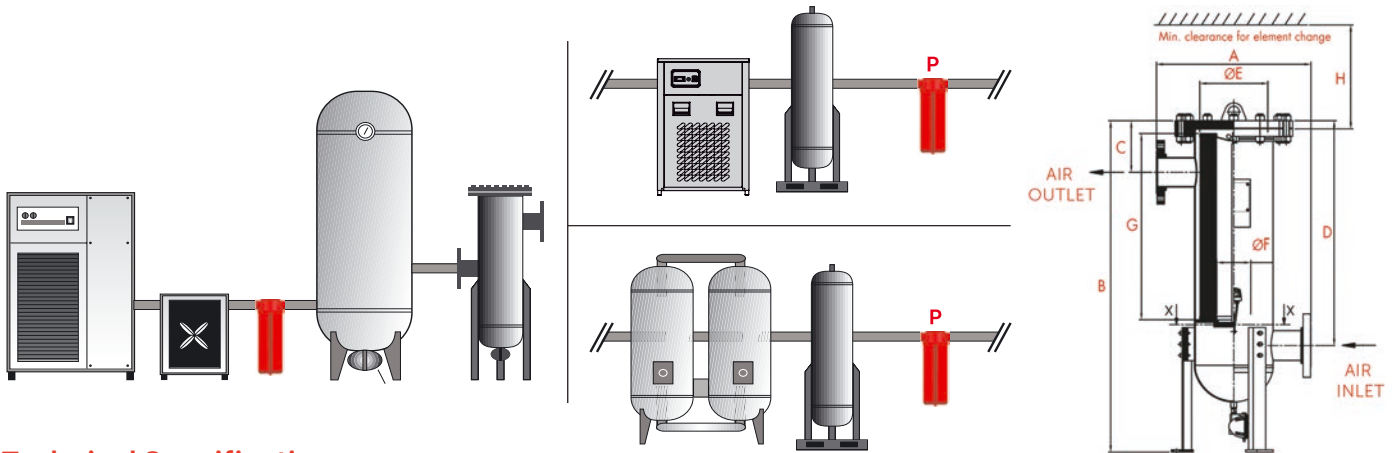

Technical Specifications

Model	Capacity		Connection Size			Housing Dimensions (mm)				
	(Nm ³ /h)	(scfm)				A	B	C	D	E
G-ELM100	35	20	3/8"	1/2"	-	102	45	257,5	235,5	165
G-ELM100	35	20	3/8"	1/2"	-	102	45	257,5	235,5	165
G-ELM100	35	20	3/8"	1/2"	-	102	45	257,5	235,5	165
G-ELM100	35	20	3/8"	1/2"	-	102	45	257,5	235,5	165
G-ELM150	45	25	1/2"	3/4"	1"	123	45	302,5	275,5	205
G-ELM200	50	30	3/4"	1"	-	123	45	366,5	339,5	265
G-ELM250	70	40	3/4"	1"	-	123	45	406,5	379,5	315
G-ELM300	85	50	1"	1 1/4"	1 1/2"	123	45	463	427,5	365
G-ELM500	100	60	1 1/4"	1 1/2"	-	123	45	493	457,5	395
G-ELM600	130	75	1 1/4"	1 1/2"	-	123	45	538	502,5	440
G-ELM851	170	100	1 1/4"	1 1/2"	2"	160	45	625,5	583,8	495
G-ELM1210	200	120	2"	-	-	160	45	695,5	653,8	565

Technical Specifications

Model	Drain Port Size	Inlet/Outlet Port Size	Flow Rate		Max. Working Pressure (bar)	Housing Dimensions (mm)							
			(m ³ /h)	(cfm)		A	B	C	D	ØE	ØF	G	H
ELM-150	1/2"	DN50	255	150	14	500	1003	209	459	203	103	305	330
ELM-300	1/2"	DN50	510	300	14	500	1105	209	559	203	103	407	435
ELM-600	1/2"	DN50	1020	600	14	500	1461	209	916	203	103	762	790
ELM-800	1/2"	DN80	1360	800	14	500	1655	279	1084	203	103	915	950
ELM-1200	1/2"	DN80	2040	1200	14	500	1520	281	931	254	103	762	790
ELM-1600	1/2"	DN80	2720	1600	14	500	1671	281	1086	254	103	915	950
ELM-2100	1/2"	DN100	3570	2100	14	500	1575	335	953	300	129	762	790
ELM-2750	1/2"	DN100	4675	2750	14	500	1726	335	1100	300	129	915	950
ELM-4200	1/2"	DN150	7140	4200	14	500	1670	393	983	365	181	762	790
ELM-6000	1/2"	DN150	10200	6000	14	500	1925	393	1238	365	181	950	1045
ELM-8000	1/2"	DN200	13600	8000	14	500	2020	417	1277	386	233	1016	1045
ELM-10000	1/2"	DN250	17000	10000	14	500	2118	417	1307	407	337	1016	1045
ELM-12000	1/2"	DN300	20400	12000	14	500	2688	497	1847	437	337	1524	1550

▶ HIGH PRESSURE COMPRESSED AIR FILTERS

FILTRATION AND SEPARATION ◀

High Pressure & High Performance



Features

Drytec manufactures a line of High Performance Compressed Air Filters, Moisture Separators in two different ranges; 50 bar range made of Aluminium. No welding, strong and reliable design.

350 bar range made of Steel. No welding and designed for reliability at very high pressure applications.

Anodised Aluminium Design with High Performance

Drytec High Pressure Range Compressed Air Filters are NO-weld design. These Filters are built with ample wall thickness and as a result are extremely robust. In-house high pressure test facilities assure the performance. All inner and outer surfaces of 50 bar Aluminium design Filters are Anodised, where 350 bar Carbon Steel design Filters are epoxy electro powder coated.

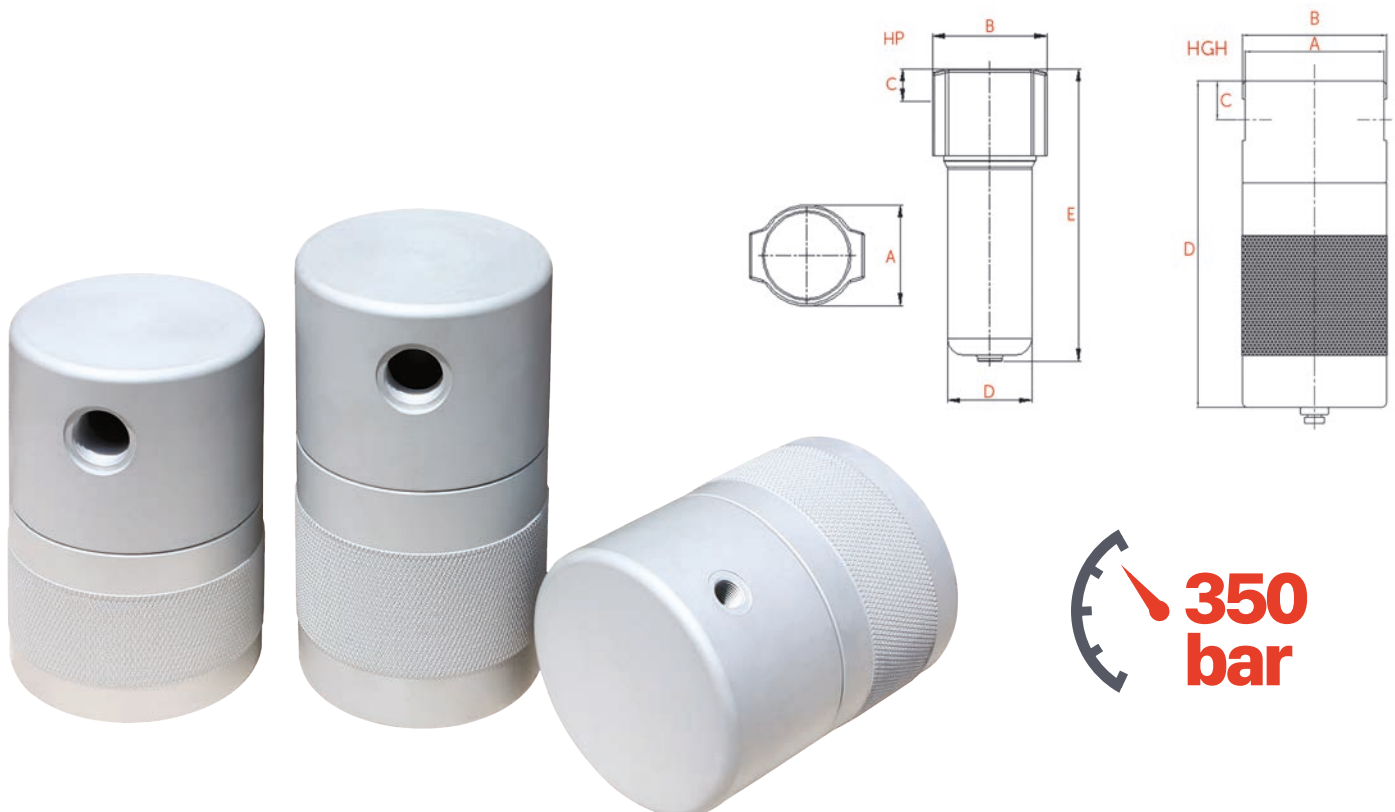

► HIGH PRESSURE COMPRESSED AIR FILTERS

Technical Specifications

Model	Drain Port Size	Flow Rate at 50 bar		Max. Working Pressure (bar)	Element Model	Housing Dimensions (mm)				
		(m ³ /h)	(cfm)			A	B	C	D	E
HP100	1/4"	71	42	50	M25	106	119	30	88	201
HP300	1/2"	212	125	50	M50	106	119	30	88	201
HP600	3/4"	425	250	50	M100	106	119	30	88	201
HP850	1"	595	350	50	M150	123	140	39.5	103	357
HP1200	1"	850	500	50	M200	123	140	39.5	103	357
HP1600	1 1/2"	1600	940	50	M250	123	140	39.5	103	357
HP2500	2"	2500	1470	50	M2500	159	179	56	133	380
HP3000	2 1/2"	3000	1765	50	M3000	159	179	56	133	380

Model	Drain Port Size	Flow Rate at 350 bar		Max. Working Pressure (bar)	Element Model	Housing Dimensions (mm)			
		(m ³ /h)	(cfm)			A	B	C	D
HGH100	1/4"	102	60	350	M25	113.4	115.4	25.75	155
HGH300	1/2"	298	175	350	M50	113.4	115.4	25.75	158.5
HGH600	3/4"	595	350	350	M100	109.4	115.4	32.25	207
HGH850	1"	850	500	350	M150	133	138	37.35	250
HGH1200	1"	1190	700	350	M200	133	138	37.35	314
HGH1600	1 1/2"	2240	1317	350	M250	128	138	44.4	368
HGH2500	2"	3500	2058	350	M2500	145	158	51.5	393
HGH3000	2 1/2"	4200	2470	350	M3000	160	178	57.6	386

Specifications	Pre Filtering	General Purpose	Oil Removal	Activated Carbon	Drain Type
Grade	P	X	Y	A	HP - Manual Brass Drain
Particle Removal (Micron)	5	1	0.01	0.01	HGH - Manual Brass Drain
Max. Oil Carryover at 21°C (mg/m ³)	5	0.5	0.01	0.003	
Max. Working Temperature (°C)	80	80	80	25	
Initial Pressure Loss (mbar)	40	80	100	80	
Pressure Loss for Element Change (mbar)	700	700	700	700	
Element Color Code	White	White	White	Metal SS	

Notes

- Grade A must not operate in oil saturated conditions.
- Grade A elements should be replaced periodically to suit the applications but must be changed at least every six months.
- Grade A will not remove certain gases including carbon monoxide and carbon dioxide. Please refer to works if in doubt.
- Flow rates are based on a 7 bar operating pressure, for flows at other pressures use correction factor given above.
- All filters are suitable for use with mineral and synthetic oils.
- Other standards for flanged connections are available.
- Direction of air flow is inside to out, through filter element.

Ordering

The complete filter model number contains the size and grade, Example - 1/4" general purpose filter model HP100MX with replacement filter element model M100X.

03

COMPRESSED AIR DRYERS

SDE SERIES AIR DRYERS	38
ICE CUBE (IC) STATIC AIR DRYERS	44
HIGH TEMPERATURE AIR DRYERS	45
CYCLING (THERMAL MASS) AIR DRYERS	46
MK HP HIGH PRESSURE SERIES	48
ISO STANDARDS	51
MODULAR DESICCANT AIR DRYERS	52
HEATLESS DESICCANT AIR DRYERS	54
HEATED DESICCANT AIR DRYERS	57



COMPRESSED
AIR DRYERS

▶ **SDE SERIES** AIR DRYERS INTEGRATED FILTRATION

COMPRESSED AIR DRYERS ◀

Drytec is aware of the importance of high quality compressed air and guarantees to provide customers with the highest quality of air. Using clean, dry air is extremely important for all kinds of air powered applications. Moisture or contamination in the air which will come from the standard compressor outlet will cause complicated system errors. These complications will decrease productivity and may affect the production quality of final products.

Advantages

- Low pressure drop saves compressor power
- Quick start and reaction time provides additional production time
- Every dryer is specially designed with the right components to consume the lowest energy
- Highly energy-efficient R134a refrigerant is standard across all models
- A state-of-the-art heat exchanger design provides the highest cost saving in the industry
- Best in class refrigerant compressors consume less energy against competition dryers
- Pressure switches control the condenser's fan motor for saving energy and letting the system operate at desired conditions
- This is not only a dryer, but an air treatment package that delivers an air quality of class 1.4.1 as per ISO 8573:2010 due to integrated filtration

Applications

Drytec provides an entire range of products for filtration and air purification applications at a cost effective price.

Applications Include

Food production, dairies, breweries, clean conveying air, chemical plants, pure air and cleanroom technology, pharmaceutical industry, weaving machines, photo labs, paint spraying, powder coating, packaging, control and instrument air, sand and/or shot blasting, general air works, microchip production, optics, process air as well as many other markets.

The SDE Series Refrigerant Circuit and Insulation

Drytec only uses environmentally friendly R134a refrigerant gas in the dryers. This refrigerant is suitable for both low and high temperature applications. R-134a has excellent thermodynamic properties and can operate at very low pressure compared to other refrigerants. This will in turn increase the refrigerant compressor's service life. With R-134a Drytec dryers can operate at very high ambient temperatures. Drytec engineers add extra power to the heat exchangers with excellent and extraordinary no loss insulation system. Drytec dryers supply constant dew point at all flow ranges. This perfect insulation idea continues on the refrigeration circuit side as well. With this insulation concept and oversized condensers (Even for ultra-high ambient temperatures). Drytec Refrigerated Air Dryers offer the highest technology with its custom solutions.



Digital Controllers

Digi-Pro digital controller is standard on SDE-25 - SDE-3700

ESD digital controller is standard on SDE-4800 - SDE-11800

Digi-Pro Digital Controller

Drytec now produces a new generation of air dryers with Digi-Pro series controllers. With the Digi-Pro series controllers, air dryers have outstanding technology for both functionality and dynamism, as well as appearance. New controller design offers users the possibility of making adjustments with one finger, thus easier accessibility. The touch keys have taken the design and dynamism to a top level of technology. The multi-functional display provides an accurate digital dew point display as well as coded alarm monitoring of the refrigerant dryer.

Digital controller with embedded features,

- Digital dew point monitoring
- Energy-saving mode display
- Periodic maintenance interval display
- Status report
- Hours run meter
- Fahrenheit and Centigrade selection

ESD Digital Controller

Drytec Refrigerated Air dryers with ESD Digital controller have a lot of economy features and alarm capabilities. Refrigeration dryers are usually the most efficient dryer solution for the compressed air applications. With the help of the highly engineered ESD, Drytec Refrigerated Air Dryers will reduce your energy consumption. ESD helps the service technicians to monitor many useful parameters on the dryer and guides them to troubleshoot any problem very easily. ESD is extremely useful when there is no air coming into the dryer when the dryer is running. Especially during the nights, weekends and holidays many companies do not stop their dryers although they do not run compressed air. ESD saves huge amount of money by simply shutting the dryer down automatically when it is not in use.



Electrical Wires are Separated From Refrigerant Side

There are very few electrical wires inside the refrigerant side of the dryer. Electrical box has an external cover with access from the outside of the dryer. Therefore there is no need to open dryer panels electrical access.

Compact Design

Drytec dryers are highly reliable, efficient and have small space demands and offer low cost ownership. Drytec Refrigerated Air Dryers are suitable for the smallest installation spaces. Having two filters integrated into the dryer frame offers a huge advantage to the service technicians and end users. The integrated filters save labor time, piping cost and space at the facilities where the Drytec Dryer is used. The compact size also offers flexibility and economy during their transport.

Aluminium Plate Heat Exchanger is Standard

- Very low pressure drop
- Thin aluminium plate thickness
- High heat transfer surface area
- Strong due to external thick cylindrical wall
- Water separator is optimized for best performance

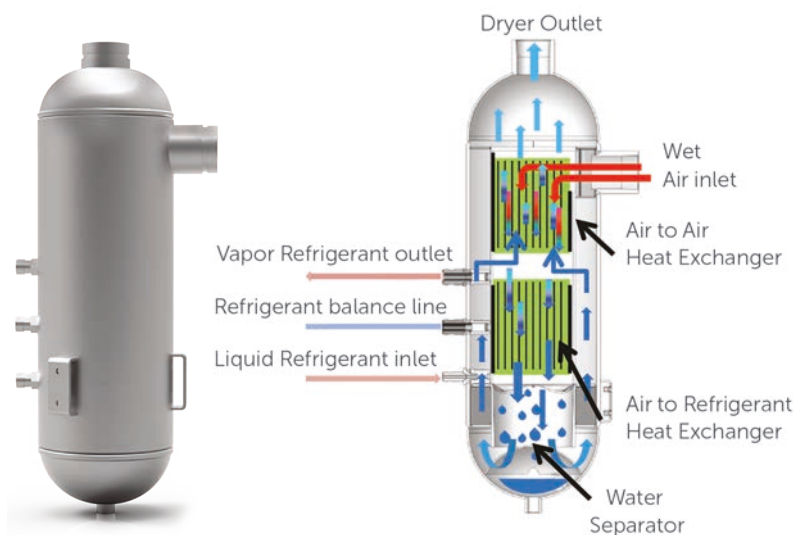
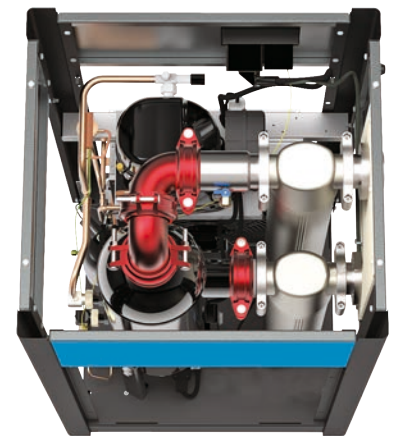

Scroll Compressors

Scroll Compressors are energy efficient and strong against liquid shocks. For energy saving, scroll compressors are used for 400 m³/h and above SDE Dryers.

Easy Access

Easy access to the cooling components in seconds by the help of screw free panels and plastic handles. Easy for service and offers more working space. Service technicians save time by not having to remove fasteners.



► SDE SERIES AIR DRYERS INTEGRATED FILTRATION

Zero Clearance Compressed Air Filters with High Performance Elements

Compressed Air Filter kit is standard on the Drytec Dryers. The filter with X Element (coalescing filter for water removal) is used for up to 1 micron particles and the filter with Y Element (coalescing filter for oil removal) is used to remove oil down to 0.01 ppm. Zero clearance design helps service technicians to replace the element in minutes.

Drytec Refrigerated Air Dryers are designed by engineers who have received all of the design feedback from field engineers and service technicians. This service friendly design makes Drytec dryers very unique in the industry. Dryer Filter kit which has two elements, two automatic drains and two viton o-rings helps the customers to operate the dryer at its best performance until the next planned maintenance. Replacing drains on the filters is critical when replacing elements because drains will get clogged with dirt and oil over time.

Grooved Couplings and Fittings

On compressed air lines, grooved couplings and fittings are commonly used in the industry. These couplings increase flexibility on connections, help the service technician to dismantle and assemble pipes easily and quickly.

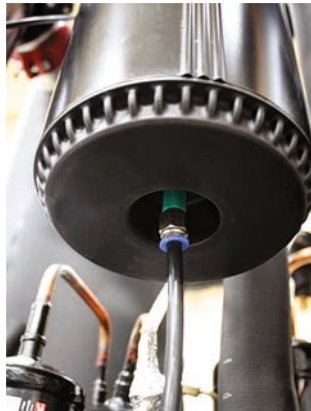

Excessive Water Droplet Drains

Liquid water droplets coming from the line to the inlet of the dryer are separated by the inlet filter and drained. Filter auto drains have manual valves on them. This allows the system to be depressurized when these filters go to service.

COMPRESSED AIR DRYERS ◀



Replacement Filter Element

Pressure drop is a huge concern in compressed air. In many applications high pressure drops will cause a decrease in the pressure at the point of use. Sometimes this low pressure is not enough for the machines or processes to perform correctly. In addition, dirt particles and oil in the compressed air system may block the filters quickly. It is important for the end users and service technicians to recognize if there is a problem in the system. The performance of the filters directly affects the pressure drop and system performance. Therefore, it is very important that the filter elements are changed at the filter service time. An alarm/warning indicating that the filters are changed periodically is provided by a digital controller on the Drytec Air Dryer. When this alarm triggers, the filter must be changed to avoid loss of performance and pressure drop.



Correction Factor for SDE Air Dryers

Inlet Temperature (°C)	F1	Ambient Temperature (°C)	F2	Pressure (bar)	F3
30	1.29	20	1.05	4	0.80
35	1	25	1	6	0.94
40	0.92	30	0.98	7	1
45	0.78	35	0.93	8	1.04
50	0.65	40	0.84	10	1.11
60	0.45	50	0.7	12	1.16
-	-	-	-	14	1.22
-	-	-	-	16	1.25

Example for Choosing the Correct Dryer;

If a compressor delivers 200 m³/h at 6 bar the dryer inlet temperature is 40°C and ambient temperature is 30°C

Please choose your Dryer as follows;

$$200 / 0.94 / 0.92 / 0.98 = 236 \text{ m}^3/\text{h}$$

The correct dryer for this application is SDE-310

SDE Technical Specifications

Model	Capacity (m ³ /h)	Voltage	Connection Size	Filter Quantity and Type	Element Type	Pressure Drop (mbar)	Control Type	Max. Working Pressure (bar)	Max. Ambient Temp. (°C)	Max. Inlet Temp. (°C)
SDE-25	23	230/1/50	1/2"	1*GK045X + 1* GK045Y	MK045 KIT	115	Digi-Pro	16	50	60
SDE-40	38	230/1/50	1/2"	1*GK045X + 1* GK045Y	MK045 KIT	170	Digi-Pro	16	50	60
SDE-55	53	230/1/50	1/2"	1*GK045X + 1* GK045Y	MK045 KIT	280	Digi-Pro	16	50	60
SDE-70	70	230/1/50	1/2"	1*GK070X + 1* GK070Y	MK070 KIT	250	Digi-Pro	16	50	60
SDE-100	100	230/1/50	3/4"	1*GK0150X + 1* GK0150Y	MK0150 KIT	100	Digi-Pro	16	50	60
SDE-160	155	230/1/50	3/4"	1*GK0150X + 1* GK0150Y	MK0150 KIT	220	Digi-Pro	16	50	60
SDE-190	190	230/1/50	3/4"	1*GK0150X + 1* GK0150Y	MK0150 KIT	320	Digi-Pro	16	50	60
SDE-210	210	230/1/50	1 1/2"	1*GK0500X + 1* GK0500Y	MK0500 KIT	220	Digi-Pro	16	50	60
SDE-310	305	230/1/50	1 1/2"	1*GK0500X + 1* GK0500Y	MK0500 KIT	320	Digi-Pro	16	50	60
SDE-380	375	230/1/50	1 1/2"	1*GK0500X + 1* GK0500Y	MK0500 KIT	200	Digi-Pro	16	50	60
SDE-500	495	230/1/50	2"	1*GK0851X + 1* GK0851Y	MK0851 KIT	310	Digi-Pro	16	50	60
SDE-600	588	230/1/50	2"	1*GK01210X + 1* GK01210Y	MK01210 KIT	210	Digi-Pro	16	50	60
SDE-830	825	230/1/50	2"	1*GK01210X + 1* GK01210Y	MK01210 KIT	120	Digi-Pro	16	50	60
SDE-1100	1100	230/1/50	2"	1*GK01210X + 1* GK01210Y	MK01210 KIT	160	Digi-Pro	16	50	60
SDE-1300	1310	400/3/50	3"	1*GK01820X + 1* GK01820Y	MK01820 KIT	200	Digi-Pro	16	50	60
SDE-1650	1628	400/3/50	3"	1*GK01820X + 1* GK01820Y	MK01820 KIT	265	Digi-Pro	16	50	60
SDE-2200	2200	400/3/50	3"	1*GK02700X + 1* GK02700Y	MK02700 KIT	150	Digi-Pro	16	50	60
SDE-2600	2620	400/3/50	3"	1*GK02700X + 1* GK02700Y	MK02700 KIT	310	Digi-Pro	16	50	60
SDE-3150	3144	400/3/50	DN100	Not Included	Not Included	240	Digi-Pro	16	50	60
SDE-3700	3696	400/3/50	DN100	Not Included	Not Included	340	Digi-Pro	16	50	60
SDE-4800	4800	400/3/50	DN100	Not Included	Not Included	280	ESD-3	16	50	60
SDE-5500	5522	400/3/50	DN100	Not Included	Not Included	310	ESD-3	16	50	60
SDE-6600	6584	400/3/50	DN150	Not Included	Not Included	280	ESD-3	16	50	60
SDE-7450	7434	400/3/50	DN150	Not Included	Not Included	310	ESD-3	16	50	60
SDE-8500	8496	400/3/50	DN150	Not Included	Not Included	310	ESD-3	16	50	60
SDE-9900	9912	400/3/50	DN200	Not Included	Not Included	310	ESD-3	16	50	60
SDE-11800	11800	400/3/50	DN200	Not Included	Not Included	310	ESD-3	16	50	60

Note: Water condenser is available between models SDE-600 and SDE-11800

Static Air Dryers

DST Air Dryers have static condensers without a cooling fan. Therefore they are energy efficient with low noise level and compact design. DST Air Dryers also have long service life and low maintenance needs.

Advantages

- Superior energy saving due to static condenser
- Efficient refrigerant compressor with low pressure drop
- +7°C dew point
- No condenser blockage due to wide condenser design
- Standard expansion valve
- 3-in-1 heat exchanger design (air/air - air/refrigerant - water separator in one block)
- Easy to service auto-drain
- High pressure switch
- No loss of compressed air (Zero Loss)
- Less refrigerant gas used than equivalents, environmentally friendly

Applications

Ideal for hospitals and laboratories with compact design and low noise needs. DST Air Dryers are also suitable for other applications which need dry air with a low price.



Model	Capacity (m³/h)	Voltage	Connection Size	Absorbed Power (kw)	Max. Amp.	Fuse Amp.	Refrigerant Gas	Pressure Drop (mbar)	Max. Working Pressure (bar)	Max. Ambient Temp. (°C)	Max. Inlet Temp. (°C)
DST50	50	230/1/50	1/2"	0.28	2.98	4	R-134a	140	16	43	50
DST70	70	230/1/50	1/2"	0.31	2.08	4	R-134a	170	16	43	50
DST100	100	230/1/50	1/2"	0.43	4.8	8	R-134a	200	16	43	50
DST130	130	230/1/50	3/4"	0.56	4.8	8	R-134a	180	16	43	50

Model	Length (mm)	Width (mm)	Height (mm)	Weight (kg)
DST50	396	366	520	21
DST70	396	366	520	23
DST100	396	366	520	25
DST130	396	366	758.5	34

Aluminium Plate Heat Exchanger

- High heat transfer surface area
- Strong due to thick external wall
- Low pressure drop
- Water Separator is optimized for best performance

Correction Factor for DST Air Dryers

For maximum flow rate, multiply model flow rate show in the table below by the correction factor corresponding to the working pressure.

Inlet Temperature (°C)	F1	Ambient Temperature (°C)	F2	Pressure (bar)	F3
30	1.29	20	1.05	4	0.80
35	1	25	1	6	0.94
40	0.92	30	0.98	7	1
45	0.78	35	0.93	8	1.04
50	0.65	40	0.84	10	1.11
-	-	43	0.81	12	1.16
-	-	-	-	14	1.22
-	-	-	-	16	1.25

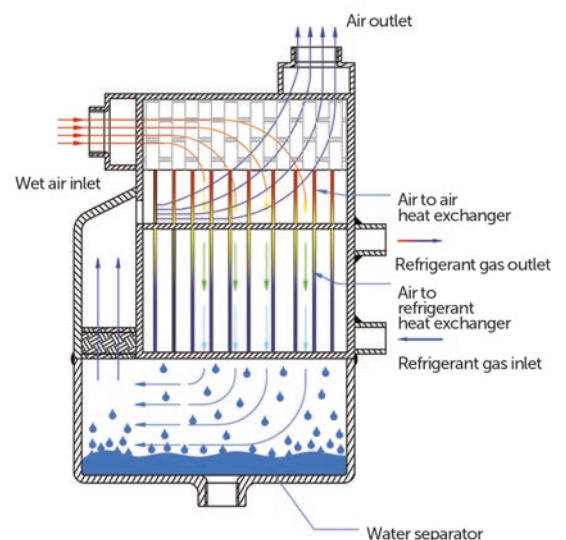

▶ HIGH TEMPERATURE AIR DRYERS

COMPRESSED AIR DRYERS ◀

Most compressor manufacturers do not use an aftercooler on their piston type compressors. Therefore compressed air exits the compressor at about 100°C temperature. Drytec's High Temperature Dryer has an aftercooler to reduce the inlet temperature.

After Cooler Condenser Inside

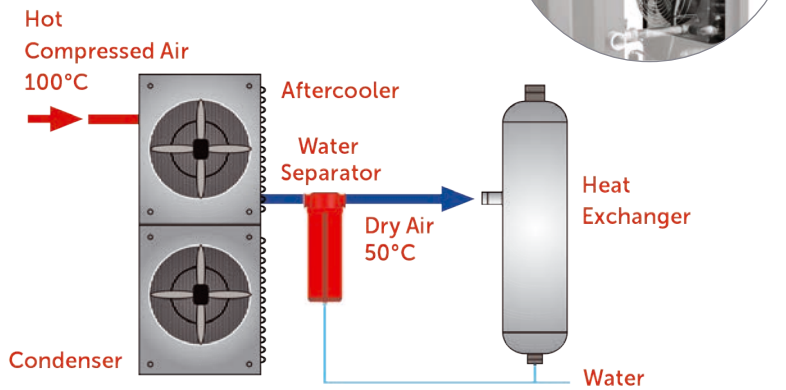

Technical Specifications

Model	Capacity (m³/h)	Voltage	Connection Size	Refrigerant Gas	Max. Working Pressure (bar)	Max. Ambient Temp. (°C)	Max. Inlet Temp. (°C)	Dimensions (mm)		
								Width	Length	Height
SDH31	31	230/1/50	1/2"	R-134a	16	45	104	445	445	955
SDH52	52	230/1/50	1/2"	R-134a	16	45	104	445	445	955
SDH75	75	230/1/50	1/2"	R-134a	16	45	104	445	445	955
SDH106	106	230/1/50	3/4"	R-134a	16	45	104	445	445	955
SDH160	160	230/1/50	3/4"	R-134a	16	45	104	510	625	910
SDH212	212	230/1/50	3/4"	R-134a	16	45	104	510	625	910

Correction Factor for SDH Air Dryers

Pressure (bar)	F1	Inlet Temperature (°C)	F2	Ambient Temperature (°C)	F3	Dew Point (°C)	F4
4.1	0.70	4	1.40	4	1.10	3.3	0.65
5	0.75	10	1.40	10	1.10	5	0.73
6	0.80	16	1.40	16	1.10	7.2	0.80
7	0.83	21	1.40	24	1.10	10	1
7.9	0.86	26	1.35	29	1.07	12.8	1.10
8.5	0.90	32	1.30	35	1.03	15.5	1.22
10	0.93	38	1.27	38	1		
11	0.96	65	1.06	40	0.96		
12	1	82	1	45	0.82		
13	1.10	93	0.85	-	-		
14	1.12	98	0.78	-	-		
16	1.15	104	0.75	-	-		

Save ENERGY

Drytec Cycling Dryers cool a special liquid and store it in a cold tank at 1°C temperature. This liquid is cycled in the dryer to cool down compressed air. This technology helps the customers to consume less ENERGY when the dryer gets 5-95% air flow. Drytec Cycling dryer outperforms non-cycling or frequency driven dryers where energy consumption is concerned. All components that are exposed to cooling liquid mixture are either stainless steel (Tank, Pump) or Aluminium (Dryer Heat Exchanger) Therefore there is no risk of corrosion.

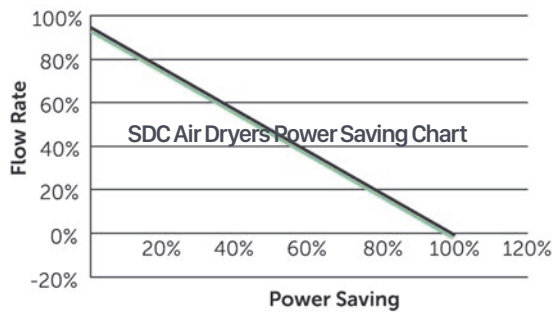

Example for Choosing the Correct Dryer

If an air compressor delivers 500 m³/h at 6 bar, the dryer inlet temperature is 45°C and ambient temperature is 30°C.

Please choose your dryer model as follows; $500 / 0.94 / 0.78 / 0.98 = 695 \text{ m}^3/\text{h}$
The correct dryer model for this application is SDC930.

Correction Factor for SDC Air Dryers

Inlet Temperature (°C)	F1	Ambient Temperature (°C)	F2	Pressure (bar)	F3
30	1.29	20	1.05	4	0.80
35	1	25	1	6	0.94
40	0.92	30	0.98	7	1
45	0.78	35	0.93	8	1.04
50	0.65	40	0.84	10	1.11
60	0.45	50	0.7	12	1.16
65	0.38	-	-	14	1.22
-	-	-	-	16	1.25

Technical Specifications

Model	Capacity (m³/h)	Voltage	Connection Size	Replacement Filter Element Kit	Dimensions (mm)		
					Width	Length	Height
SDC-495	495	230/1/50 Hz	2"	MKO-851 KIT	725	855	1505
SDC-623	623	230/1/50 Hz	2"	MKO-1210 KIT	725	855	1505
SDC-930	930	230/1/50 Hz	2"	MKO-1210 KIT	730	830	1765
SDC-1200	1200	400/3/50 Hz	2"	MKO-1210 KIT	730	830	1765
SDC-1388	1388	400/3/50 Hz	3"	MKO-1820 KIT	800	1150	1740
SDC-1800	1800	400/3/50 Hz	3"	MKO-1820 KIT	800	1150	1740
SDC-2500	2500	400/3/50 Hz	3"	MKO-2700 KIT	880	1315	1790
SDC-2775	2775	400/3/50 Hz	3"	MKO-2700 KIT	880	1315	1790
SDC-3330	3330	400/3/50 Hz	DN100	N/A	850	1400	1840
SDC-3915	3915	400/3/50 Hz	DN100	N/A	850	1400	1840
SDC-5085	5085	400/3/50 Hz	DN100	N/A	1080	1620	1995
SDC-5850	5850	400/3/50 Hz	DN100	N/A	1080	1620	1995
SDC-6975	6975	400/3/50 Hz	DN150	N/A	1065	2190	2025
SDC-7875	7875	400/3/50 Hz	DN150	N/A	1065	2190	2025
SDC-9000	9000	400/3/50 Hz	DN150	N/A	1200	2900	2120
SDC-10500	10500	400/3/50 Hz	DN200	N/A	1200	2900	2120
SDC-12500	12500	400/3/50 Hz	DN200	N/A	1550	2550	2170

Max. Ambient Temperature (°C) : 50°C
 Nominal Ambient Temperature (°C) : 25°C
 Max. Inlet Temperature (°C) : 65°C
 Nominal Inlet Temperature (°C) : 35°C

Max. Working Pressure (bar) : 16 bar
 Nominal Working Pressure (bar) : 7 bar
 Refrigerant Gas : R134a

► MK HP HIGH PRESSURE SERIES

COMPRESSED AIR DRYERS ◀

This design achieves a hyper-efficient 100% contact between the air and refrigerant circuits, delivering state-of-the-art performance and great cooling efficiency.

The state-of-the-art 3-in-1 design features very low differential pressure delivering significant energy savings. The 3-in-1 Heat-Exchanger is compact and allows the dryer to be smaller and reduces the space required for the dryer. Drytec offers a variety of 3-in-1 dryers equipped with the 3-in-1 Heat-Exchanger to meet a full range of capacity and power requirements.

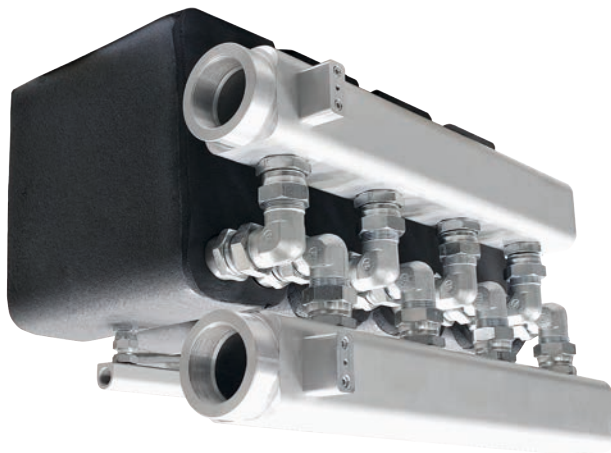

40 bar



Drytec High Pressure Dryers have stainless steel brazed plate heat exchangers.

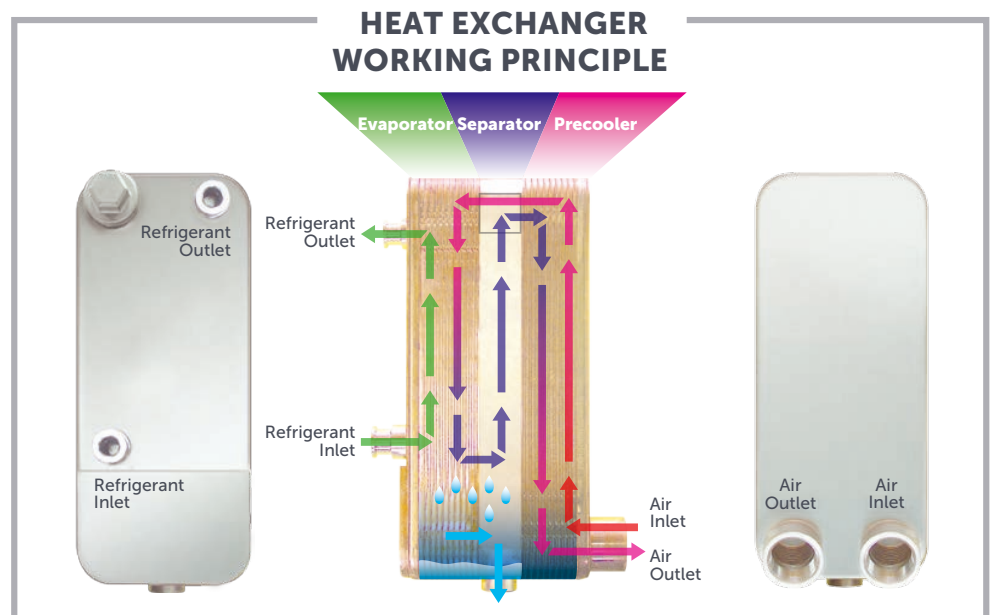
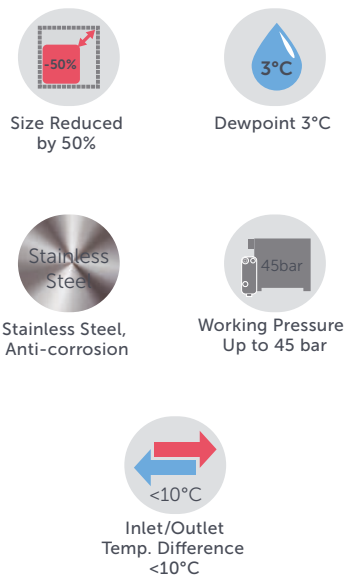

Drytec MK-HP range High Pressure Air Dryer Series have state of the art stainless steel brazed plate heat exchanger. It is designed for high pressure air dryers. The heat exchanger has the following sections in one module;

- Air/Air heat exchanger (Economizer)
- Air/Refrigerant heat exchanger (Evaporator)
- Water separator

With reliable stainless steel and optimized efficiency design, Drytec MK-HP heat exchangers supply size reduction, anti corrosion and great heat transfer.

The Separator Efficiency

- Double centrifugation due to the bottom fin
- Reserved direction for the compressed air
- Gravity effect to the condensed water
- Special anti-return system
- Separator integrated to the system

Frigorific Circuit

- Two valve regulation system (thermal and by-pass), allowing to fill properly the exchanger and giving a max. temperature to the exchanger
- High quality security test of potential leakage
- Use of hermetic compressor as standard
- High quality, long lasting components
- Quick start and reaction time

Scroll Compressor

- Better coefficient of power
- Less energy consumption
- Higher resistance to liquid shocks



Technical Specifications

Model	Flow* (m ³ /h)	Voltage	Inlet - Outlet Connection Size	Max. Working Pressure (bar)	Max. Ambient Temp. (°C)	Max. Inlet Temp. (°C)	Width (mm)	Lenght (mm)	Height (mm)	Weight (kg)
MK HP 50	50	230V/1/50 Hz	3/4"	45	45	50	361	454	553	36
MK HP 90	90	230V/1/50 Hz	3/4"	45	45	50	361	454	553	38
MK HP 150	150	230V/1/50 Hz	3/4"	45	45	50	401	453	623	45
MK HP 220	220	230V/1/50 Hz	3/4"	45	45	50	401	453	623	45
MK HP 300	300	230V/1/50 Hz	1 1/4"	45	45	50	451	505	761	70
MK HP 400	400	230V/1/50 Hz	1 1/4"	45	45	50	451	505	761	72
MK HP 500	500	230V/1/50 Hz	1 1/4"	45	45	50	451	505	812	78
MK HP 575	575	230V/1/50 Hz	1 1/4"	45	45	50	451	505	812	80
MK HP 775	775	230V/1/50 Hz	1 1/4"	45	45	50	501	675	984	115
MK HP 910	910	230V/1/50 Hz	1 1/4"	45	45	50	501	675	984	120
MK HP 1000	1000	230V/1/50 Hz	2"	45	45	50	727	947	1170	218
MK HP 1160	1160	230V/1/50 Hz	2"	45	45	50	727	947	1170	220
MK HP 1500	1500	230V/1/50 Hz	2"	45	45	50	727	947	1170	225
MK HP 1600	1600	400V/3/50 Hz	2"	45	45	50	797	947	1460	263
MK HP 1800	1800	400V/3/50 Hz	2"	45	45	50	797	947	1460	265
MK HP 2200	2200	400V/3/50 Hz	2 1/2"	45	45	50	797	1162	1495	352
MK HP 2500	2500	400V/3/50 Hz	2 1/2"	45	45	50	797	1162	1495	353
MK HP 2700	2700	400V/3/50 Hz	2 1/2"	45	45	50	797	1162	1495	355
MK HP 3000	3000	400V/3/50 Hz	2 1/2"	45	45	50	797	1162	1495	422
MK HP 3300	3300	400V/3/50 Hz	2 1/2"	45	45	50	797	1162	1495	423
MK HP 3600	3600	400V/3/50 Hz	2 1/2"	45	45	50	797	1162	1495	425

* Nominal flow is calculated at the following conditions: Inlet Pressure: 40 bar, Inlet Temperature: 35°C
Ambient Temperature 25°C for other conditions please refer to the correction factor table.

Correction Factor for MK HP High Pressure Series

Pressure (bar)	F1	Inlet Temp. (°C)	F2	Ambient Temp. (°C)	F3
20	0.84	-	-	-	-
25	0.91	-	-	-	-
30	0.93	-	-	-	-
35	0.96	-	-	-	-
40	1	35	1	25	1
45	1.02	40	0.85	30	0.93
-	-	45	0.72	35	0.87
-	-	50	0.63	40	0.82
-	-	-	-	45	0.79

For maximum flow rate, multiply model flow rate show in the table below by the correction factor corresponding to the working pressure.

Maximum Pressure (45 bar)
Nominal Working Pressure (40 bar)
Refrigerant: R134a

AIR LINE DESIGN	AIR LINE DESIGN 1	APPLICATION	ISO 8573.1: 2010 CLASS
<p>COMPRESSOR → AFTER-COOLER → MOISTURE SEPARATOR → RECEIVER TANK → EXTERNAL AUTO DRAIN</p>	<p>COMPRESSED AIR FILTERS</p>	SIMPLE	2.-3
	<p>AIR LINE DESIGN 2</p> <p>REFRIGERANT AIR DRYER</p> <p>COMPRESSED AIR FILTERS</p> <p>COMPRESSED AIR FILTERS</p>	GENERAL PURPOSE	1.4.1
	<p>AIR LINE DESIGN 3</p> <p>REFRIGERANT AIR DRYER</p> <p>COMPRESSED AIR FILTERS</p> <p>COMPRESSED AIR FILTERS</p>	ODORLESS	1.4.1
	<p>AIR LINE DESIGN 4</p> <p>COMPRESSED AIR FILTERS</p> <p>DESICCANT DRYER</p> <p>COMPRESSED AIR FILTERS</p>	CRITICAL	1.2.1 (-40 °C / -40°F) 1.1.1 (-70 °C / -94 °F)

Purity Class	ISO 8573.1: 2010 Compressed Air Quality Standard							
	Solid Particulate					Water		Oil
	Max. number of Particles per m ³			Particle Size (micron)	Concentration (mg/m ³)	Vapor Pressure Dew Point	Liquid (g/m ³)	Total Oil (Aerosol, Liquid and Vapor) (mg/m ³)
	0.1-0.5 micron	0.5-1 micron	1-5 micron					
0	As specified and determined by equipment user and supplier							
1	≤20000	≤400	≤10	-	-	≤-70°C	-	≤0.01
2	≤400000	≤6000	≤100	-	-	≤-40°C	-	≤0.1
3	-	≤900000	≤1000	-	-	≤-20°C	-	≤1
4	-	-	≤10000	-	-	≤+3°C	-	≤5
5	-	-	≤100000	-	-	≤+7°C	-	-
6	-	-	-	5	5	≤+10°C	-	-
7	-	-	-	40	10	-	0.5	-
8	-	-	-	-	-	-	5	-
9	-	-	-	-	-	-	10	-

for Solid Particles	for Water	for Oil
P - Class 3	Drytec Air Dryers are Class 3	P - Class 3
X - Class 3		X - Class 3
Y - Class 1	Drytec Desiccant Air Dryers are A - Class 1	Y - Class 1
A - Class 1		A - Class 1

The light weight modular design desiccant dryer series brings a new concept in compressed air technology, offering total installation flexibility to meet specific needs.

Drytec's Modular Desiccant Dryers are less than half the weight and size of a traditional twin tower design, allowing even the largest models to be easily moved through a standard doorway. Drytec's innovative Modular Air Dryers make it easier and more affordable than ever to deliver high-quality compressed air for virtually wherever it's needed.

Drytec Modular Desiccant Dryers have cosmetic beauty and can be located in clean, pleasant environments eyesore. Offered in sizes from 5 m³/h to 400 m³/h with dew point of -40°C to -70°C (optional) these dryers are equipped with everything you need, requiring only air inlet/outlet connections.

Using a highly engineered inlet and purge manifold design, Drytec proudly offers one of the lowest pressure drop desiccant dryer in the industry.

- Small footprint, lightweight, advanced compact design
- Corrosion protected Aluminium construction
- Hassle-free, reliable electronic controls
- Can be floor, bench or wall mounted
- Quiet enough to be placed in any work environment
- Easy installation, easy maintenance

The new Modular Desiccant Dryers combine proven traditional dryer principles with the latest technology to provide unsurpassed efficiency, flexibility and world-renowned Drytec reliability for your critical dry air applications.

Various Application Options

Modular Desiccant Air Dryers can be mounted to the wall with easy-to-use mounting brackets to free up additional space and can also be secured to the ground very easily.



Technical Specifications

Model	Capacity		Voltage	Connection Size	Max. Working Pressure (bar)	Dimensions			
	(m ³ /h)	(cfm)				Width (mm)	Length (mm)	Height (mm)	Weight (kg)
MDD3	5	3	115-240V/50-60 Hz.	1/2"	16	320	336	558	17
MDD5	10	5	115-240V/50-60 Hz.	1/2"	16	320	320	633	19
MDD10	20	10	115-240V/50-60 Hz.	1/2"	16	320	320	908	27
MDD15	25	15	115-240V/50-60 Hz.	1/2"	16	370	350	808	31
MDD20	35	20	115-240V/50-60 Hz.	1/2"	16	370	350	1108	42
MDD25	45	25	115-240V/50-60 Hz.	1/2"	16	370	350	1258	48
MDD30	50	30	115-240V/50-60 Hz.	1/2"	16	370	350	1508	54
MDD40	70	40	115-240V/50-60 Hz.	1 1/2"	16	410	495	1250	71
MDD50	85	50	115-240V/50-60 Hz.	1 1/2"	16	410	495	1400	78
MDD60	100	60	115-240V/50-60 Hz.	1 1/2"	16	410	495	1750	92
MDD75	130	75	115-240V/50-60 Hz.	1 1/2"	16	430	622	1300	120
MDD100	170	100	115-240V/50-60 Hz.	1 1/2"	16	430	622	1450	133
MDD120	200	120	115-240V/50-60 Hz.	1 1/2"	16	430	622	1750	152
MDD180	300	180	115-240V/50-60 Hz.	1 1/2"	16	410	734	1499	186
MDD240	400	240	115-240V/50-60 Hz.	1 1/2"	16	410	889	1497	235

Pressure Dew Point	Nominal Inlet Temperature	Nominal Working Pressure	Maximum Inlet Temperature	Maximum Working Pressure	Maximum Ambient Temperature
40°C / 70°C (opt)	35°C	7 bar	50°C	16 bar	50°C

Correction Factor

Pressure (bar)	F1	Inlet Temp. (°C)	F2
4.5	0.69	20	1
5	0.75	25	1
6	0.88	30	1
7	1	35	1
8	1.12	40	0.80
9	1.25	45	0.73
10	1.37	50	0.59
11	1.50	-	-
12	1.62	-	-
13	1.74	-	-
14	1.87	-	-
15	1.99	-	-
16	2.11	-	-

PLC Monitor

The mini PLC is user friendly and shows the working action simultaneously. It is possible to get an alarm signal or remote control thanks to an easy access plug below the dryer. Dew point control and monitoring is possible with a dew point sensor.

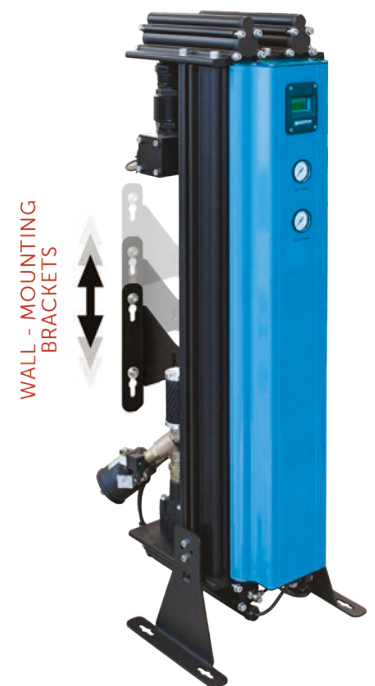

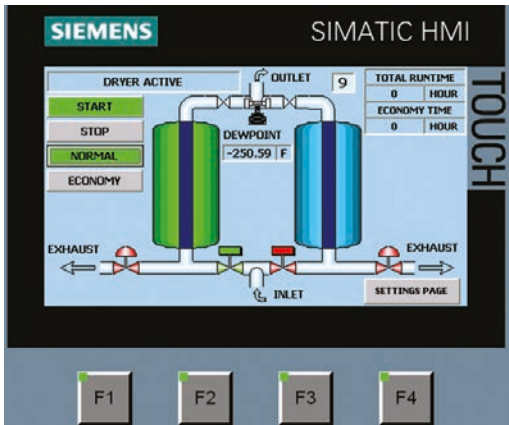

PLC is Standard

MDA Desiccant Dryers have an extremely reliable electronic controller for optimal performance over the lifetime of the dryers. The touch screen PLC is capable of showing the cycles as well as the valves as they operate in real time. This is also capable of showing dew points. User friendly multi-lingual PLC helps the end users understand the operation of the system and identify any issues easily.



Correction Factor

Pressure (bar)	F1	Inlet Temp. (°C)	F2
4.5	0.69	20	1
5	0.75	25	1
6	0.88	30	1
7	1	35	1
8	1.12	40	0.80
9	1.25	45	0.73
10	1.37	50	0.59



Activated Alumina

In order to achieve consistent dew point, Drytec uses a mixture of adsorption media in its heatless range of desiccant dryers. Activated Alumina, Molecular Sieve and Silica Gel are used in varying ratios depending on the application.

All desiccant dryers are designed according to Pneurop conditions as per ISO 7183.

Ordering

If a compressor delivers 850 m³/h at 9 bar pressure and 45°C inlet temperatures please choose your dryer as follows; 850/1.25/0.73 = 931 m³/h the correct dryer for this is MDA1000

Technical Specifications

Model	Connection Size	Inlet Flow Rate		Voltage	Max. Working Pressure (bar)	Pressure Drop (mbar)	Total Weight (Packed) (kg)	Active Alumina (kg)	Dimensions (mm)		
		(m³/h)	(cfm)						Width	Length	Height
MDA 130	1"	130	80	230/1/50-60	10	≤130	160	40	600	814	1312
MDA 185	1"	185	100	230/1/50-60	10	≤130	180	54	600	808	1566
MDA 250	1"	250	150	230/1/50-60	10	≤130	200	75	760	772	1580
MDA 300	1 1/2"	300	200	230/1/50-60	10	≤130	250	100	690	900	1558
MDA 360	1 1/2"	360	215	230/1/50-60	10	≤130	250	100	690	900	1558
MDA 440	1 1/2"	440	250	230/1/50-60	10	≤130	340	1250	698	900	1759
MDA 575	1 1/2"	575	300	230/1/50-60	10	≤130	500	151	680	900	1991
MDA 680	2"	680	400	230/1/50-60	10	≤130	535	202	680	960	2216
MDA 850	2"	850	500	230/1/50-60	10	≤130	750	264	857	1016	2277
MDA 1000	2"	1000	600	230/1/50-60	10	≤130	755	357	1010	1075	2386
MDA 1250	DN80/PN16	1250	700	230/1/50-60	10	≤130	1000	404	1100	1294	2413
MDA 1500	DN80/PN16	1500	800	230/1/50-60	10	≤130	1050	454	1010	1300	2547
MDA 1800	DN80/PN16	1800	1000	230/1/50-60	10	≤130	1215	566	1110	1513	2479
MDA 2200	DN80/PN16	2200	1250	230/1/50-60	10	≤130	1550	708	1110	1460	2793
MDA 2700	DN80/PN16	2700	1500	230/1/50-60	10	≤130	1890	852	1252	1533	2831
MDA 3200	DN100/PN16	3200	1750	230/1/50-60	10	≤130	2240	954	1212	1653	3054
MDA 3600	DN100/PN16	3600	2000	230/1/50-60	10	≤130	2330	1070	1210	1653	3268
MDA 4400	DN100/PN16	4400	2500	230/1/50-60	10	≤130	3000	1436	1535	1905	2910
MDA 5000	DN150/PN16	5000	3000	230/1/50-60	10	≤130	3180	1670	1714	1843	3382
MDA 6300	DN150/PN16	6300	4000	230/1/50-60	10	≤130	3450	2016	1693	2114	3328
MDA 7200	DN150/PN16	7200	4500	230/1/50-60	10	≤130	3600	2446	1795	2518	3047
MDA 8800	DN150/PN16	8800	5000	230/1/50-60	10	≤130	3850	2906	1795	2518	3341
MDA 10800	DN200/PN16	10800	6000	230/1/50-60	10	≤130	4200	3354	1875	2583	3747
MDA 12500	DN200/PN16	12500	7360	230/1/50-60	10	≤130	6470	3894	1935	2545	4175

Efficiency Rating	X Pre Filter	Y Pre Filter	P After Filter
	1 micron particle removal and 0.5 mg/m³ oil removal	0.01 micron particle removal and 0.1 mg/m³ oil removal	5 micron particle removal (Removes desiccant particles after the dryer)

*For special requirements please contact our Technical Department.

Pressure Dew Point	Nominal Inlet Temperature	Nominal Working Pressure	Maximum Inlet Temperature	Maximum Working Pressure	Maximum Ambient Temperature
-40°C / -70°C (opt)	35°C	7 bar	50°C	10 bar	50°C

Drytec MDA Heatless Desiccant Air Dryers provide constant -40°C (-70°C is optional) pressure dew point. These dryers are designed to supply clean and dry compressed air for critical applications. Pre and after-filters are supplied along with Drytec Heatless Air Dryers to keep the air stream clean and maintain the integrity of the desiccant medium.

Drytec MDA Heatless Desiccant Air Dryers provide constant -40°C (-70°C Optional) pressure dew point. These dryers are designed to supply clean and very dry compressed air for critical applications. Pre-filters and after-filters are standard on all Drytec Heatless Air Dryers to keep the air stream clean and maintain the integrity of the desiccant medium. A very reliable electronic controller is utilised so the dryer operates perfectly through its service life. MDA Heatless Desiccant Dryers are equipped with special valves and high quality desiccants in order to assure performance and provide the lowest pressure drops available in the market.



Principle of Operation

The twin tower design allows for continuous adsorption of water vapor from compressed air by using the hygroscopic desiccant with high crush strength and a high surface/volume ratio. Drying is accomplished by passing compressed air through one desiccant bed adsorbing moisture while the other is being simultaneously regenerated with the expanded purge air.

Regeneration of desiccant is accomplished without the use of heat. The wet bed is dried by diverting a small portion of the super-dry air from the outlet at near atmospheric pressure. The purge flow rate is adjustable to suit the specific outlet conditions (desired dew point). The super dry air flows in a counter direction through the wet bed, sweeping all the water vapor previously absorbed by the desiccant. MDA ensures pressure equalization in the twin towers prior to switching.

This prevents line surge and minimizes desiccant attrition. The tower being reactivated will be gradually re-pressurized at the end of its reactivation cycle before switch over takes place. Purge flow and de-pressurization are in downward direction, counter to the drying air flow.

This saves ENERGY and helps the world become more "GREEN"



A centrifugal blower and high efficiency heater eliminate the use of valuable compressed air for desiccant regeneration. The completely automatic drying system uses blower to pull ambient air and pass it through the heater. This hot air stream flows opposite to drying flow direction. Hot air above 200°C regenerates the moisture inside desiccant bed and strips it completely of all moisture. The advanced control system monitors the dew point and adjusts the heating/regeneration accordingly thereby providing valuable energy savings.

- Dew point monitoring and control
- Computer Control-Display Status
- Display Alarms-Display Pressure
- Remote Start/Stop-Low Pressure Alarm
- Minimum pressure monitoring valve
- High pressure switches and alarms
- Externally heated or heatless dryer functions integrated to the MBP

Correction Factor

Pressure (bar)	F1	Inlet Temp. (°C)	F2
4.5	0.69	20	1
5	0.75	25	1
6	0.88	30	1
7	1	35	1
8	1.12	40	0.80
9	1.25	45	0.73
10	1.37	-	-



Technical Specifications

Model	Capacity (m³/h)	Connection Size	Max. Working Pressure (bar)	Pressure Drop (mbar)	Voltage	Average Power (kw)	Fuse Amp.	Active Alumina (kg)	Dimensions (mm)		
									Width	Length	Height
MBP 850	850	2"	10	≤130	400/3/50	9,4	36	264	1290	1180	2299
MBP 1000	1000	2"	10	≤130	400/3/50	9,4	36	357	1200	1310	2415
MBP 1250	1250	DN80	10	≤130	400/3/50	12	50	404	1610	1270	2468
MBP 1500	1500	DN80	10	≤130	400/3/50	12	50	454	1610	1270	2563
MBP 1800	1800	DN80	10	≤130	400/3/50	14,5	65	566	1563	1515	2479
MBP 2200	2200	DN80	10	≤130	400/3/50	17,5	70	708	1563	1455	2789
MBP 2700	2700	DN80	10	≤130	400/3/50	21,4	87	852	1615	1514	2836
MBP 3200	3200	DN100	10	≤130	400/3/50	21,4	87	954	1710	1660	3054
MBP 3600	3600	DN100	10	≤130	400/3/50	31,1	121	1070	1710	1660	3268
MBP 4400	4400	DN100	10	≤130	400/3/50	36,1	121	1436	1975	2492	2910
MBP 5000	5000	DN125	10	≤130	400/3/50	39,4	136	1670	2045	2560	3382
MBP 6300	6300	DN150	10	≤130	400/3/50	49,4	170	2016	2090	2963	3328
MBP 7200	7200	DN150	10	≤130	400/3/50	49,4	170	2446	2020	3363	3047
MBP 8800	8800	DN150	10	≤130	400/3/50	72,3	250	2906	2020	3363	3341
MBP 10800	10800	DN200	10	≤130	400/3/50	78,7	280	3354	2492	3481	3765

Pressure Dew Point	Nominal Inlet Temperature	Nominal Working Pressure	Maximum Inlet Temperature	Maximum Working Pressure	Maximum Ambient Temperature
-40°C	35°C	7 bar	45°C	10 bar	40°C



04

GAS TREATMENT AND GAS GENERATION

PSA NITROGEN GENERATOR	60
ACTIVATED CARBON TOWER	66
BREATING AIR SYSTEM (MBS SERIES)	68

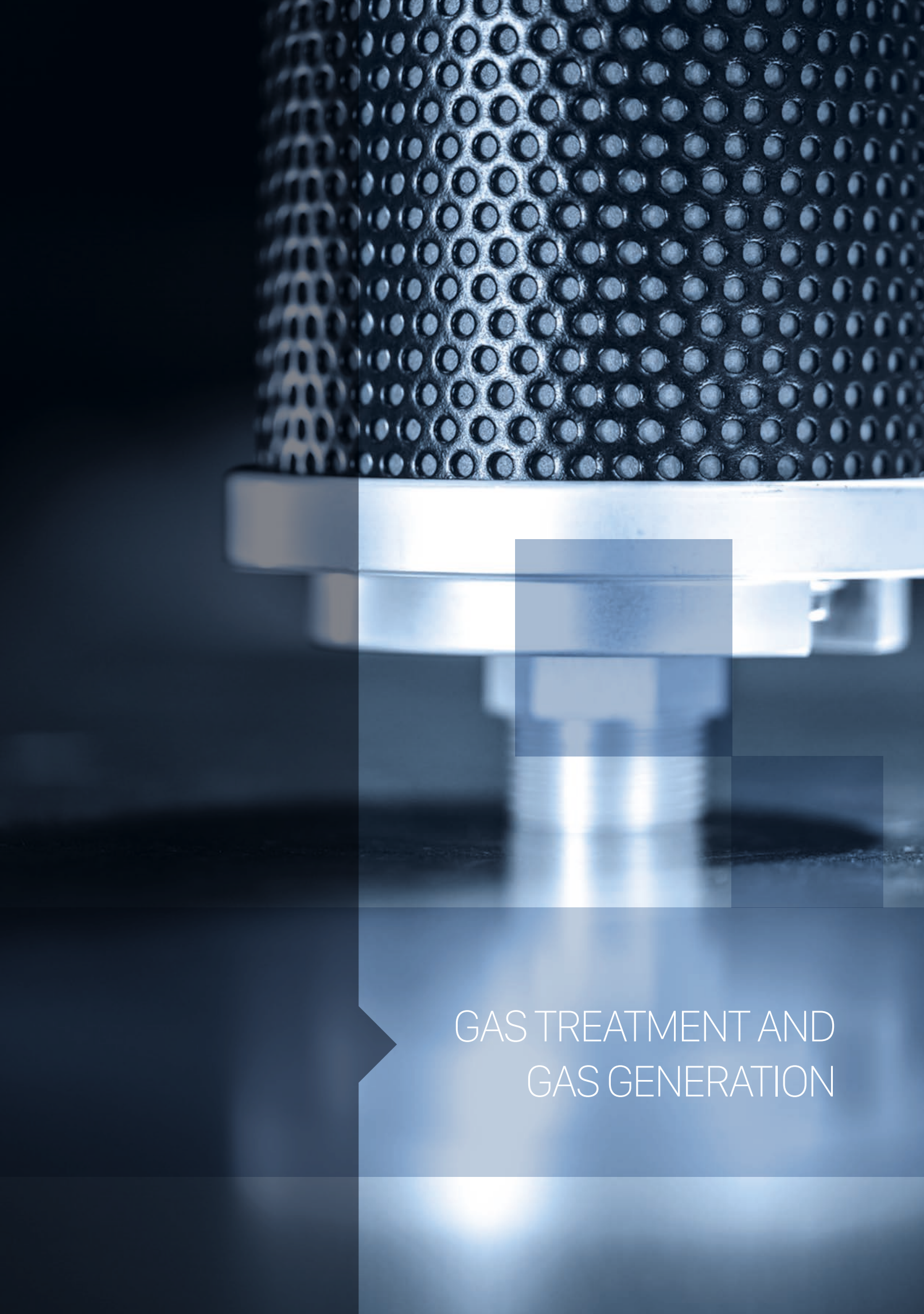

GAS TREATMENT AND
GAS GENERATION

▶ PSA NITROGEN GENERATOR

Pressure Swing Adsorption (PSA) type Nitrogen Generation system that is used to separate and enrich Nitrogen from Oxygen employs CMS (Carbon Molecular Sieve) for adsorbent. Carbon Molecular Sieve (CMS) adsorbs Oxygen and Water Vapor molecules under certain pressure while allowing Nitrogen to pass through.

The Nitrogen Generator is a Two-Bed Adsorber System

The Nitrogen Generator consists of two adsorber vessels filled with CMS, a valve assembly, air filters, main pressure regulator, and a product receiver tank. Clean and dry air is directed to one of the adsorber beds where oxygen and water vapor is adsorbed faster than nitrogen in the pore structure of the CMS, thus increasing the nitrogen purity of the product gas stream to the desired level (95-99.999% as required by customer). This product flows out from the top of the adsorber bed, through the valve and into the product receiver at a pressure slightly below the feed air pressure.



Applications

- Metal industry
- Chemical industry
- Purge
- Plastic industry
- Charge nitrogen gas in tires
- Production process and storage of food

Optional

- Dew Point Sensor (pic.3 see next page)

Standard

- Oxygen Analyzer / Nitrogen purity sensor
- Flow Meter
- Activated Carbon Tower
- Compressed air filters (P grade) after carbon tower and after buffer tank
- Nitrogen Generator / Silencer
- Basic Logo or Crouzet mini PLC for modular type
- Siemens HMI color touch screen PLC for twin towers
- Buffer Tank

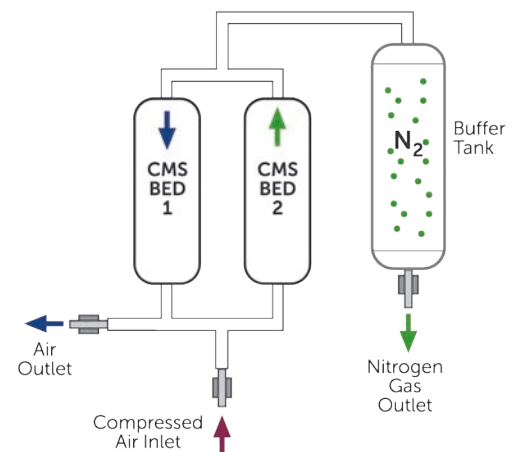
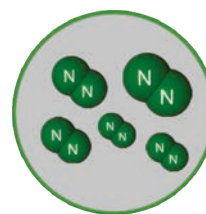

Features

- Simple structure, compact design, full automated operation
- Replaces manifold usage (see pic .1)
- Touch Screen PLC for controlling the complete system (see pic. 2)
- PLC Screen for monitoring and visualizing the progress
- Rapid start-up and safety system
- Superior silencer design gives low noise levels during depressurization and purge (see pic. 4)
- Durable piston valves for long-life operation (see pic. 5)
- On demand production, low cost
- High performance
 - *The purity and capacity of nitrogen gas is designed to meet customer requirements (Nitrogen Purity 95%~99.999% is available)
- Minimum maintenance cost.
 - *Replace filter element periodically only and service your compressor as normal



Replaces Manifold Usage - Pic. 1

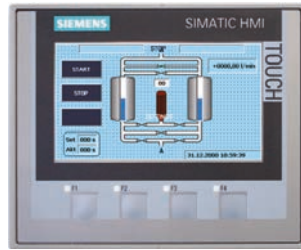

Touch Screen PLC - Pic. 2



Dew Point Sensor - Pic. 3



Pic. 4



Long Life Piston Valve - Pic. 5



Air Filter

Technical Specifications

Model	Air Demand @ Following Purity Level (m ³ /h)									
	95%	97%	98%	99%	99.50%	99.90%	99.95%	99.99%	99.999%	
DNG-10	6,3	5,6	5,1	4,5	4,1	3,5	3,1	2,8	2,2	Modular
DNG-20	10,1	9,0	8,2	7,2	7,0	5,6	5,1	4,4	3,6	
DNG-35	18,6	16,6	15,1	13,2	12,1	10,3	9,3	8,2	6,7	
DNG-60	31,0	27,6	25,1	22,0	20,2	17,1	15,5	13,6	11,1	
DNG-95	53,4	47,6	43,3	37,9	34,7	29,5	26,7	23,5	19,1	
DNG-120	71,3	63,6	57,8	50,6	46,4	39,4	35,6	31,4	25,5	
DNG-150	87,2	77,8	70,7	62,0	56,8	48,2	43,6	38,4	31,3	
DNG-250	138,8	123,8	112,5	98,6	90,3	76,7	69,4	61,1	49,7	
DNG-330	183,7	163,8	148,9	130,5	119,5	101,5	91,8	80,8	65,8	
DNG-450	248,2	221,4	201,2	176,3	161,5	137,2	124,1	109,2	89,0	
DNG-510	284,3	253,6	230,5	202,0	185,0	157,1	142,1	125,1	101,9	Twin Tower
DNG-570	315,8	281,6	256,0	224,3	205,5	174,5	157,8	139,0	113,2	
DNG-730	413,3	368,6	335,1	293,6	268,9	228,4	206,6	181,9	148,2	
DNG-910	505,6	450,9	409,9	359,1	329,0	279,4	252,7	222,5	181,2	
DNG-1110	614,6	548,2	498,3	436,6	399,9	339,7	307,2	270,5	220,3	
DNG-1230	678,0	604,7	549,7	481,6	441,2	374,7	338,9	298,4	243,1	
DNG-1370	751,3	670,1	609,1	533,7	488,9	415,2	375,5	330,6	269,3	
DNG-1820	1015,8	906,0	823,5	721,6	661,0	561,3	507,8	447,0	364,2	
DNG-2050	1185,0	1056,5	960,3	841,5	770,8	654,6	592,1	521,3	424,7	
DNG-2550	1420,1	1266,6	1151,3	1008,8	924,1	784,8	709,8	625,0	509,1	
DNG-2950	1751,6	1562,3	1420,0	1244,3	1139,8	968,0	875,6	770,9	627,9	
DNG-3540	2052,8	1830,9	1664,2	1458,2	1335,8	1134,4	1026,1	903,4	735,9	
DNG-4160	2367,2	2111,2	1919,0	1681,5	1540,3	1308,1	1183,2	1041,7	848,6	
DNG-5560	2849,7	2541,5	2310,1	2024,4	1854,0	1610,0	1424,2	1253,9	1022,2	
DNG-9170	4700,2	4191,7	3810,0	3338,5	3057,0	2655,5	2349,4	2068,1	1685,2	
DNG-11200	5740,3	5119,6	4654,5	4077,6	3734,0	3243,6	2869,4	2526,3	2057,5	

Technical Specifications

Model	Free Nitrogen Delivery @ Following Purity Level (m³/h)									
	95%	97%	98%	99%	99.50%	99.90%	99.95%	99.99%	99.999%	
DNG-10	2,7	2,2	1,9	1,5	1	0,8	0,7	0,5	0,2	Modular
DNG-20	4,4	3,5	3,1	2,4	2	1,3	1,1	0,8	0,4	
DNG-35	8,1	6,5	5,6	4,4	3,5	2,3	2,0	1,4	0,7	
DNG-60	13,5	10,8	9,4	7,3	6	3,8	3,4	2,4	1,2	
DNG-95	23,3	18,6	16,2	12,6	10,4	6,6	5,9	4,1	2,0	
DNG-120	31,0	24,8	21,6	16,8	13,9	8,8	7,8	5,5	2,7	Twin Tower
DNG-150	38,0	30,4	26,4	20,6	17,0	10,8	9,6	6,7	3,3	
DNG-250	60,5	48,3	42,1	32,7	27,1	17,2	15,2	10,6	5,3	
DNG-330	80,0	63,9	55,7	43,3	35,8	22,8	20,1	14,1	7,0	
DNG-450	108,2	86,4	75,2	58,5	48,4	30,8	27,2	19,0	9,5	
DNG-510	123,9	99,0	86,2	67,1	55,5	35,3	31,2	21,8	10,9	
DNG-570	137,6	109,9	95,7	74,5	61,6	39,2	34,6	24,2	12,1	
DNG-730	180,1	143,9	125,3	97,5	80,6	51,3	45,3	31,6	15,8	
DNG-910	220,3	176,0	153,2	119,2	98,6	62,7	55,5	38,7	19,3	
DNG-1110	267,8	214,0	186,3	145,0	119,9	76,2	67,4	47,0	23,5	
DNG-1230	295,4	236,0	205,5	159,9	132,3	84,1	74,4	51,9	25,9	
DNG-1370	327,4	261,5	227,7	177,2	146,6	93,2	82,4	57,5	28,7	
DNG-1820	442,6	353,6	307,9	239,6	198,2	126,0	111,4	77,8	38,8	
DNG-2050	516,2	412,4	359,0	279,4	231,1	146,9	130,0	90,7	45,3	
DNG-2550	618,8	494,4	430,4	334,9	277,1	176,1	155,8	108,7	54,3	
DNG-2950	763,2	609,8	530,9	413,1	341,8	217,2	192,1	134,1	67,0	
DNG-3540	894,5	714,6	622,1	484,1	400,5	254,6	225,1	157,1	78,5	
DNG-4160	1031,4	824,1	717,4	558,3	461,9	293,6	259,6	181,2	90,5	
DNG-5560	1241,7	992,0	863,6	672,1	556,0	353,4	312,5	218,1	109,0	
DNG-9170	2048,0	1636,1	1424,3	1108,4	917,0	582,9	515,5	359,7	179,7	
DNG-11200	2501,2	1998,3	1740,0	1353,8	1120,0	712,0	629,6	439,4	219,4	

Reference Conditions

Inlet Compressed Air Pressure	Outlet Nitrogen Pressure	Ambient Temperature	Inlet Air Dew Point	
7.5 bar	6 bar	25°C	3°C (Under or equal 99.5% purity)	-40°C (Above 99.5% purity)
			Refrigerant air dryer and activated carbon filter are required	Desiccant dryer and activated carbon filter are required

* For purity levels under 99.5% required air quality is class 1.4.1 as per ISO8573

* For purity levels above 99.5% required air quality is class 1.2.1 as per ISO8573

N₂ NITROGEN

Model	Buffer Tank	Connections		Dimensions (mm)		
		Air Inlet	Nitrogen Outlet	Width	Length	Height
DNG-10	26L	1/2"	1/2"	610	1120	1090
DNG-20	35 L	1/2"	1/2"	560	1081	1284
DNG-35	52 L	1/2"	1/2"	736	1179	1787
DNG-60	70 L	1/2"	1/2"	932,5	1115,5	1485
DNG-95	97 L	1"	1/2"	760	1659	1485
DNG-120	126 L	1"	1/2"	890	1634	1442
DNG-150	151 L	1"	1/2"	890	1634	1639
DNG-250	280 L	1"	1/2"	892	1760	1975
DNG-330	408 L	1"	1/2"	950	1910	2025
DNG-450	464 L	1"	1/2"	1010	2218	2134
DNG-510	515 L	1 1/2"	3/4"	1010	2208	2028
DNG-570	573 L	1 1/2"	3/4"	1010	2208	2226
DNG-730	712 L	1 1/2"	3/4"	1110	2685	2084
DNG-910	1,042 m ³	1 1/2"	1"	1220	2727	2485
DNG-1110	1,290 m ³	1 1/2"	1"	1322	2896	2521
DNG-1230	1,402m ³	2"	1"	1322	2898	2724
DNG-1370	1,498 m ³	2"	1 1/4"	1355	2895	2941
DNG-1820	2,019 m ³	2"	1 1/2"	1793	3599	2634
DNG-2050	2,336 m ³	DN80	1 1/2"	1964	3390	3124
DNG-2550	2,336 m ³	DN80	2"	2139	3666	3194
DNG-2950	2,336 m ³	DN80	2"	2245	4074	2787
DNG-3540	2,336 m ³	DN80	2"	2375	4024	3054
DNG-4160	2,336 m ³	DN80	2"	2376	4020	3361
DNG-5560	2,336 m ³	DN100	2 1/2"	2425	4125	3890
DNG-9170	2,336 m ³	DN150	DN80	2986	4502	4364
DNG-11200	2,336 m ³	DN150	DN100	4672	3081	4728

Note: Drytec supplies buffer tank volumes for 99,5% and higher Nitrogen purities. For purities lower than 99,5%, it may be necessary to use an additional tank.

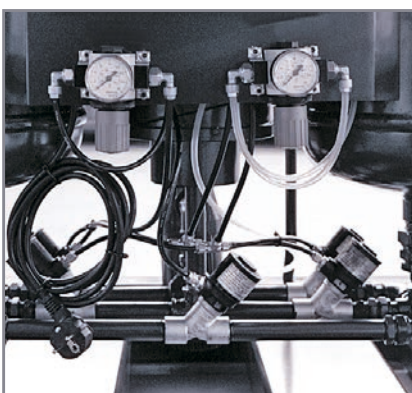

Correction Factor

Inlet Pressure (bar)	F1	Ambient Temp. (°C)	F2
6	0,82	5	0,85
6,5	0,88	10	1
7	0,94	15	1
7,5	1	20	1
8	1,05	25	1
8,5	1,1	30	0,91
9	1,14	35	0,82
9,5	1,2	40	0,74
10	1,21	45	0,6

To determine the nitrogen generator model in the reference conditions divide the nitrogen flow rate to the factors mentioned above.

▶ PSA NITROGEN GENERATOR

GAS TREATMENT AND GAS GENERATION ◀

"Drytec reserves the right to change the design and/or dimensions and/or weight of his products at any time without any notice or liability."

AIR LINE DESIGN (Under or equal 99.5% purity)

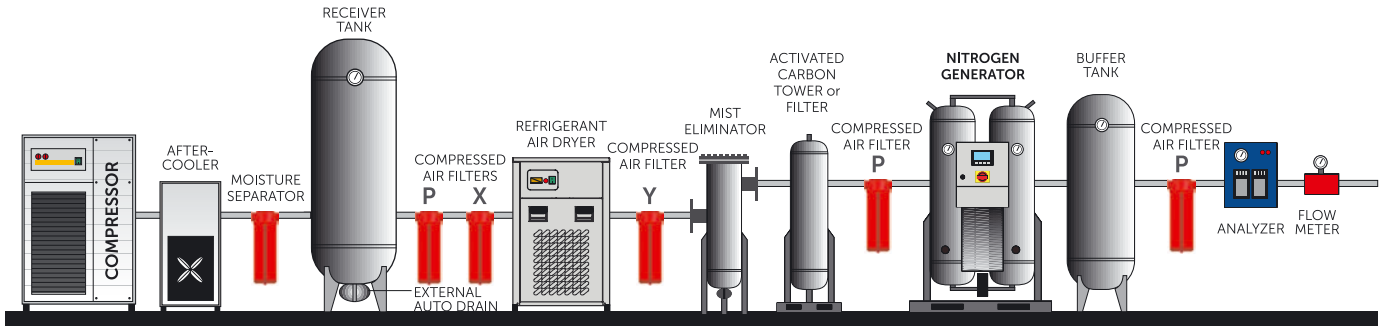

AIR LINE DESIGN (Above 99.5% purity)

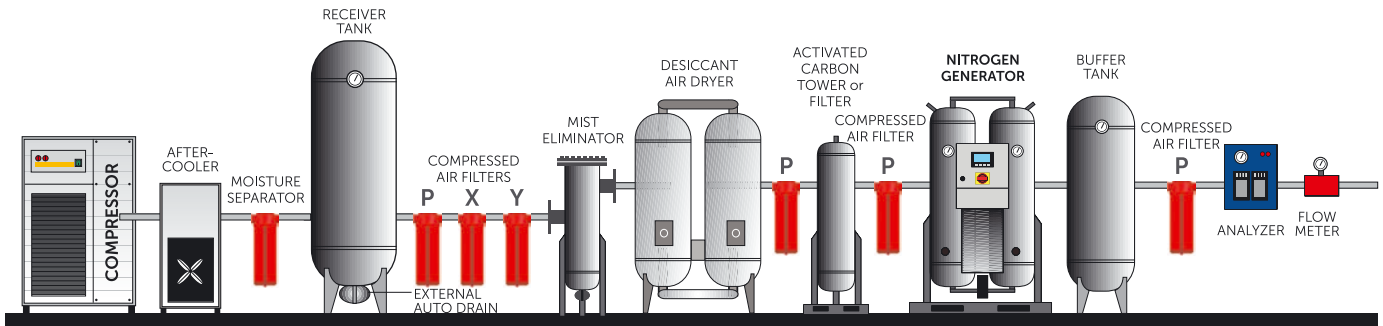

▶ ACTIVATED CARBON TOWER

Many industries such as the electronic and hospital industries, pharmaceutical industries, food and beverage sectors require the removal of residual oil vapors and odors from the compressed air. Drytec's solution for this application is the MCT Series activated carbon towers. With standard pre and after filters such as particulate filters, water coalescers and oil coalescers, the oil content inside the compressed air can be reduced to 0.01 mg/m³ (0.01 ppm) for applications of EXTREME air quality such as hospital, pharmaceutical industries, or food and beverage industries, the residual oil content may need to be reduced to 0.003 mg/m³ (0.003 ppm). MCT filters such as Drytec activated carbon G series, GO series, F series filters or MCT activated carbon towers are a must for these types of applications.

Correction Factor

Operating Pressure (bar)	PSI	Correction Factor
1	15	0,5
3	44	0,71
5	73	0,87
7	100	1
9	131	1,12
10	145	1,15

Max. Recommended Operating Temperature	Max. Oil Carryover at 21°C (mg/m ³)	Max. Working Pressure
25°C	0,003°C	10 bar

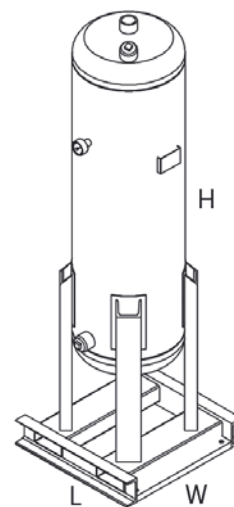
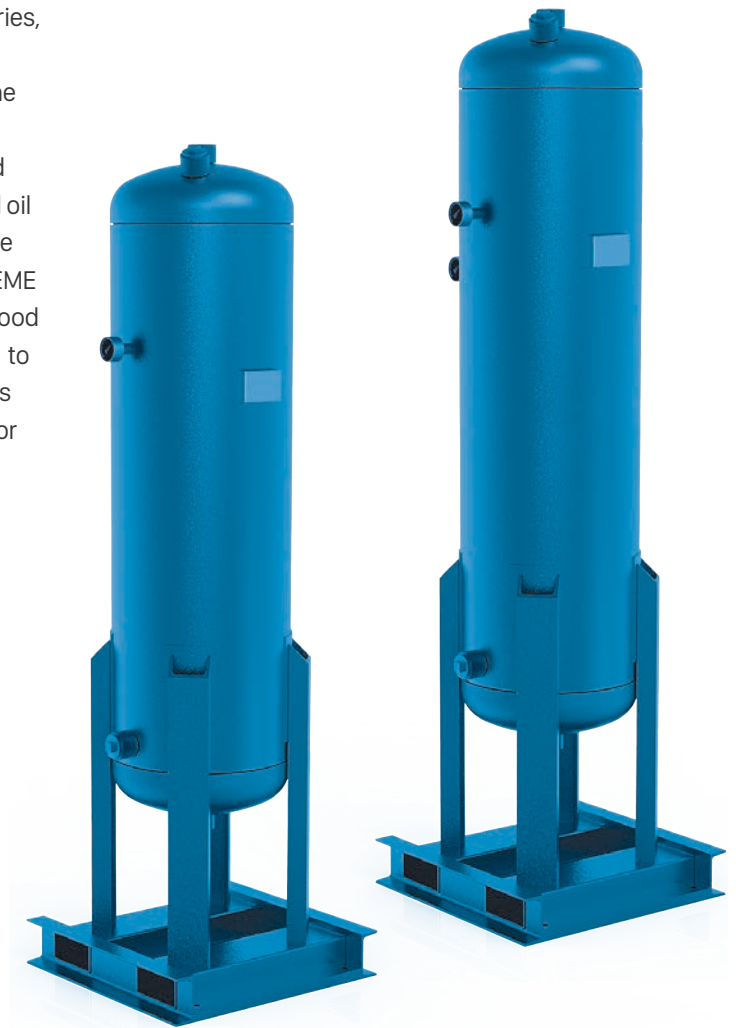
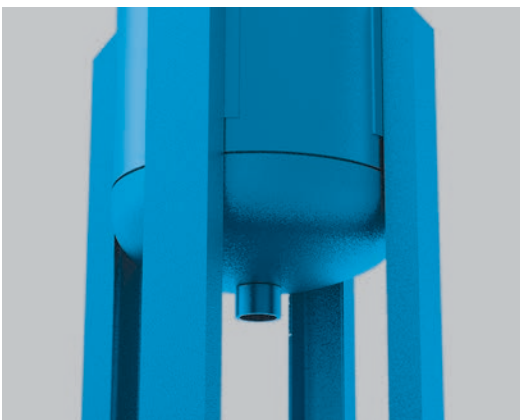

Technical Specifications

Model	Connection Size	Flow Rate (m ³ /h)	Max. Working Pressure (bar)	Active Carbon (kg)	Housing Dimensions (mm)		
					Length	Width	Height
MCT130	1"	130	10	14	347	450	1172
MCT185	1"	185	10	20	450	563	1413
MCT250	1"	250	10	28	430	601	1370
MCT300	1 1/2"	300	10	37	500	649	1336
MCT360	1 1/2"	360	10	37	500	649	1336
MCT440	1 1/2"	440	10	46	500	648	1536
MCT575	1 1/2"	575	10	56	469	604	1733
MCT680	2"	680	10	74	550	540	1936
MCT850	2"	850	10	97	580	600	1957
MCT1000	2"	1000	10	128	657	638	1617
MCT1250	DN80	1250	10	149	708	880	2400
MCT1500	DN80	1500	10	167	708	880	2558
MCT1800	DN80	1800	10	210	810	980	2423
MCT2200	DN80	2200	10	262	810	1100	2600
MCT2700	DN80	2700	10	320	910	1100	2758
MCT3200	DN100	3200	10	356	866	1050	3023
MCT3600	DN100	3600	10	400	866	1050	3237
MCT4400	DN100	4400	10	537	1130	1250	2914
MCT5000	DN100	5000	10	624	1130	1310	3420
MCT6300	DN150	6300	10	754	1230	1230	3365
MCT7200	DN150	7200	10	845	1430	1430	3075
MCT8800	DN150	8800	10	1009	1430	1430	3369
MCT10800	DN200	10800	10	1148	1430	1430	3863

BREATHING AIR SYSTEM MBS SERIES

GAS TREATMENT AND
GAS GENERATION

Breathing Air Solutions

High-quality compressed air is crucial to many industries and has a vital role in breathing air applications. Drytec breathing air purifiers are designed to eliminate hazardous substances in the air conforming to related standards. (Drytec breathing air purifiers are designed to protect against a range of contaminants that may be present in a compressed air fed breathing air system.)



Technical Specifications

Model	Capacity		Connection Size	Replacement Filter Kit Model	Voltage	Max. Working Pressure (bar)
	(m³/h)	(cfm)				
MBS 5	10	5	1/2"	G100-ELM	115-240V/50-60Hz.	16
MBS 10	20	10	1/2"	G100-ELM	115-240V/50-60Hz.	16
MBS 15	25	15	1/2"	G100-ELM	115-240V/50-60Hz.	16
MBS 20	35	20	1/2"	G100-ELM	115-240V/50-60Hz.	16
MBS 25	45	25	1/2"	G150-ELM	115-240V/50-60Hz.	16
MBS 30	50	30	1/2"	G200-ELM	115-240V/50-60Hz.	16
MBS 40	70	40	1 1/2"	G250-ELM	115-240V/50-60Hz.	16
MBS 50	85	50	1 1/2"	G300-ELM	115-240V/50-60Hz.	16
MBS 60	100	60	1 1/2"	G500-ELM	115-240V/50-60Hz.	16
MBS 75	130	75	1 1/2"	G600-ELM	115-240V/50-60Hz.	16
MBS 100	170	100	1 1/2"	G851-ELM	115-240V/50-60Hz.	16
MBS 120	200	120	1 1/2"	G1210-ELM	115-240V/50-60Hz.	16
MBS 180	300	180	1 1/2"	ELM 300	115-240V/50-60Hz.	16
MBS 240	400	240	1 1/2"	ELM 300	115-240V/50-60Hz.	16
MBS 250	440	250	1 1/2"	ELM 300	115-240V/50-60Hz.	16
MBS 300	575	300	1 1/2"	ELM 600	115-240V/50-60Hz.	16
MBS 400	680	400	2"	ELM 600	115-240V/50-60Hz.	16
MBS 500	850	500	2"	ELM 600	115-240V/50-60Hz.	16
MBS 600	1000	600	2"	ELM 600	115-240V/50-60Hz.	16
MBS 700	1250	700	DN80	ELM 800	115-240V/50-60Hz.	16
MBS 800	1500	800	DN80	ELM 1200	115-240V/50-60Hz.	16
MBS 1000	1800	1000	DN80	ELM 1200	115-240V/50-60Hz.	16
MBS 1250	2200	1250	DN80	ELM 1600	115-240V/50-60Hz.	16

Contaminants	CSA Z180.1	European Pharmacopoeia	OHSA Grade D
Water	Pressure dew point of 5°C below lowest system temp.	67 ppm (-45°C atmospheric dew point)	-
Oil/Lubricant	<1 mg/m³	0,1 mg/m³	5 mg/m³
Carbon Dioxide (CO2)	<500 ppm	<500 ppm	<1000 ppm
Carbon Monoxide (CO)	<5 ppm	<5 ppm	<10 ppm
Nitrogen Oxides (NO+NO2)	-	<2 ppm	-
Sulphur Dioxide (SO2)	-	<1 ppm	-
Oxygen (O2)	-	21±1	-
Taste and Odor	-	Free	-





36 rue de la Légende 4141 Louveigné, Belgium

☎ +32/4367 52 43 🖨 +32/4367 08 05

✉ info@drytec.be • **www.drytec.be**