



Burners for gas, double stage, aluminium frame, protection cover with noise reduction plate, combustion head with adjustment at high efficiency and high flame stability. Available in the versions Methane (natural gas) or G.P.L. (to specify at the order) on demand specific versions for town gas, coal gas or biogas.

Compact overall dimensions and disposition rationalized of the components with accessibility facilitated for the operations of setting and maintenance.

Gas train complete of working valve double stage with flow adjustment, safety valve, gas pressure switch, filter stabiliser of gas pressure, completely assembled, electrically linked and tested.

Versions F with cover of protection in steel and specific features for the application on industrial ovens and bakery ovens.

Complete of connector 7 poles, flange and gasket for installation on boiler.

TECHNICAL DATA

MODEL		GAS X1/2CE	GAS X2/2CE	GAS X3/2CE	GAS X4/2CE
Thermal power min 1° st./min 2° st.-max 2° st. *	Mcal/h	15.5/20-50	21/35-80	30/60-150	55/100-200
Thermal power min 1° st./min 2° st.-max 2° st. *	kW	18/23-58	24/41-93	35/70-174	64/116-232
Flow-rate G20 (NATURAL GAS) min 1° st./min 2° st.-max 2° st.	Nm³/h	1.8/2.3-5.8	2.5/4.1-9.4	3.5/7-17.4	6.4/11.6-23.2
Flow-rate G31 (G.L.P.) min 1° st./min 2° st.-max 2° st.	Nm³/h	0.7/0.9-2.3	0.9/1.6-3.6	1.3/2.7-6.5	2.5/4.5-9
Fuel	NATURAL GAS (second family) - LPG (third family)				
Combustible category	I _{2R} I _{2H} I _{2L} I _{2E} I _{2E+} I _{2E+} I _{2E+} I _{2ELL} I _{2E(R)B} I _{3B/P} I ₃₊ I _{3P} I _{3B} I _{3R}				
Intermittent operation (min. 1 stop every 24 hours) at double stages					
Allowed environment conditions on running/stock	-15...+40°C / -20...+70°C, relative umidity max 80%				
Maximum inlet pressure to the valves	°C	60	60	60	
Min. pressure train gas D1/2"-S NATURAL GAS/ LPG**	mbar	14/31	-	-	-
Min. pressure train gas D3/4"-FS25 NATURAL GAS/ LPG**	mbar	-	16/28	-	-
Min. pressure train gas D1"-S NATURAL GAS/ LPG**	mbar	-	-	14/31	14/21
Max pressure on the valve's inlet	mbar	60	200	360	360
Nominal electric power	W	110	130	200	226
Fan motor	W	75	75	110	200
Power absorbed	A	0.6	0.6	0.9	1.1
Power supply	1/N~230V-50Hz				
Degree of electric protection	IP40				
Noisiness *** min-max	dBA	60-61	61-62	66-69	66-69
Weight ****	kg	11	11	15	17

* Reference conditions: Room temperature 20°C - Atmospheric pressure 1013 mbars - Altitude 0 (sea level).

** Least pressure of feeding of the gas to the train to get the maximum power of the burner considering against pressure in chamber of value combustion 0 (zero)

*** Measured sonorous pressure in the laboratory combustion, with functional burner on beta boiler to 1 m of distance. (UNI EN ISO 3746)

**** For burner with iron cover (F) add 2kgs to the weight.

OPERATING RANGE: Thermal power - Pressure in combustion chamber

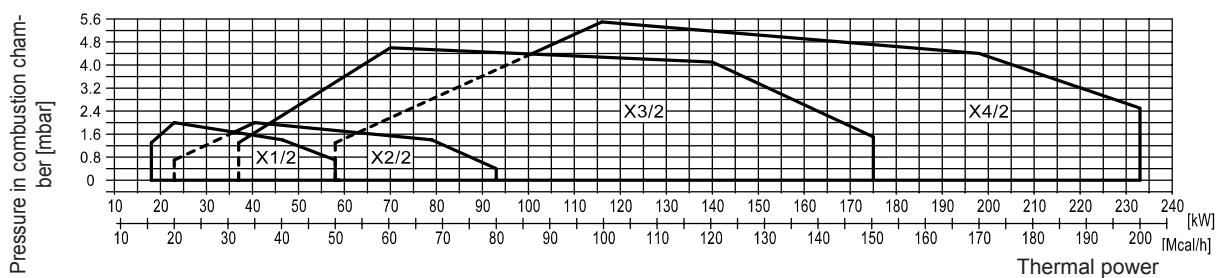

OVERALL DIMENSIONS (mm)

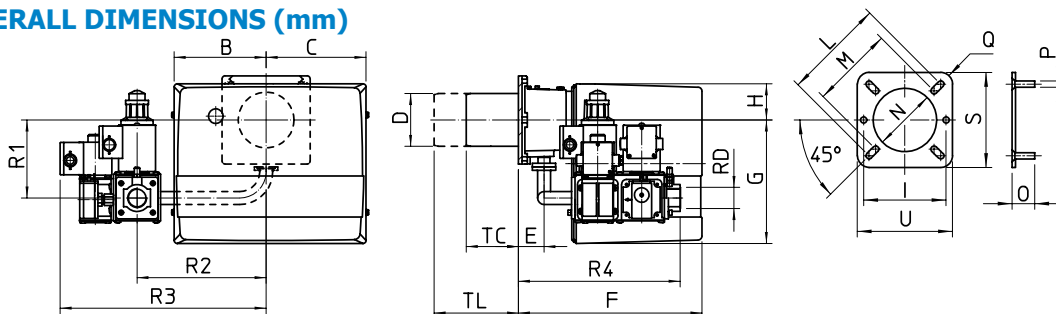

MODEL	B	C	D	E	F	G	H	I	L	M	N	O	P	Q	S	U	TC	TL	R1	R2	R3	R4	RD	Train weight
GAS X1/2CE-D1/2"-S	157	170	90	45	313	210	65	130	160	130	100	30	M8	R15	150	150	85	145	133	200	275	258	Rp 1/2	2 Kg
GAS X2/2CE-D3/4"-FS25	157	170	90	45	313	210	65	130	160	130	100	30	M8	R15	150	150	85	145	138	220	351	275	Rp 1	6 Kg
GAS X3/2CE-D1"-S	185	195	108	52	340	248	70	160	170	150	120	30	M8	R15	190	190	130	250	168	280	337	361	Rp 1	6 Kg
GAS X4/2CE-D1"-S	185	195	125	78	368	248	70	-	226	170	135	40	M10	R30	220	220	160	280	173	280	337	385	Rp 1	6 Kg