



PROFESSIONAL  
KITCHEN EQUIPMENT



yatogastro.com

**YATO**



PROFESSIONAL  
KITCHEN EQUIPMENT



**TABLE OF CONTENTS**

**Cookware 3-6**  
Pots and saucepans ..... 3-4  
Stainless steel frying pans ..... 5  
Aluminium frying pans with teflon coating ..... 6

**GN containers 7-8**  
Stainless steel GN containers ..... 7  
Polycarbonate GN containers ..... 8

**Containers, jugs, scoops 9-11**  
Buckets ..... 9  
Jugs ..... 9  
Cutlery container ..... 9  
Food storage containers ..... 10  
Kettle paddle ..... 10  
Container for bulk products ..... 11  
Scoops ..... 11

**Kitchen utensils 12-18**  
Forged steel knives ..... 12  
Kitchen scissors ..... 13  
Steel for knife sharpening ..... 13  
Knife and scissor sharpeners ..... 14  
Can opener ..... 14  
Chopping boards ..... 15  
HACCP chopping boards ..... 15  
Rods ..... 16  
Narrow spatulas ..... 16  
Universal tongs ..... 16  
Colander spoons ..... 16-17  
Sieves ..... 17  
Pizza meshes ..... 18  
Condiment dispensers ..... 18

**Buffet 19-26**  
Soup kettle ..... 19  
Buffet heaters ..... 20  
Water boilers ..... 21  
Vacuum flasks ..... 22  
Drink dispenser ..... 23  
Sauce dispensers ..... 23  
Jugs ..... 24  
Tiered platter for fruit and biscuits ..... 24  
Tongs ..... 24-25  
Buffet accessories ..... 25  
Banquet trays ..... 26  
Waiter trays ..... 26

**Bar 27-29**  
Ice buckets ..... 27  
Wine bottle cooler ..... 27  
Champagne bucket ..... 27  
Cocktail shakers ..... 27  
Reception bell ..... 28  
Citrus juicer ..... 28  
Bartending spoon ..... 28  
Bar containers and organisers ..... 28  
Glass rimmer ..... 28  
Bartender mats ..... 29  
Drink dispensers ..... 29  
Bottle opener ..... 29  
Plugs with dispensers ..... 29

**Mechanical processing equipment 30-46**  
Bone saw ..... 30  
Meat mincer with Unger system ..... 31  
Sausage stuffers ..... 32  
Hamburger presses ..... 32  
Meat and cheese slicers ..... 33  
Tomato slicers ..... 34  
Vegetable shredder ..... 35  
Discs for vegetable shredder ..... 36  
Potato peelers ..... 37  
Handheld blender ..... 37  
Bartender's blender ..... 38  
Planetary mixers ..... 39-43  
Spiral mixers ..... 44-46

**Thermal processing equipment 47-62**  
Induction cookers ..... 47  
Grill plates ..... 48  
Contact grills ..... 49-50  
Gas-fired grills ..... 51-55  
Cast iron plate for gas grills ..... 56  
Barbecue grill protective covers ..... 56  
Deep fryers ..... 57-60  
Circulator for sous vide cooking ..... 61  
Pancake maker ..... 62  
Rice cookers ..... 62

**Thermally insulated containers and cabinets for catering 63-65**  
Food transport containers ..... 63  
Thermally insulated catering containers and cabinets ..... 64-65  
Thermally insulated beverage dispenser ..... 65

**Transport and storage 66-71**  
Waiter trolleys ..... 66  
Service trolleys ..... 67  
Transport trolleys ..... 68  
Platform trolley ..... 69  
Work tables ..... 70  
Slatted racks ..... 71  
Hanging shelves ..... 71

**Vacuum packaging machines 72-76**  
Vacuum packaging machine ..... 72  
Adjustable packaging machines ..... 73-74  
Free-standing packaging machines ..... 74  
Bags for vacuum packaging machines ..... 75  
Industrial vacuum packaging machine ..... 76

**Refrigeration 77-94**  
Cooling and freezing cabinets ..... 77  
Cooling and freezing tables ..... 78-82  
Freezing cabinet for ice cream cuvettes ..... 82  
Glass cooling cabinets and tables ..... 83  
Cabinets and tables for bakery ..... 84  
Salad cooling tables ..... 85  
Pizza cooling tables ..... 86  
Accessories for cooling cabinets and tables ..... 87  
Cooling extensions ..... 88  
Refrigerated display cases for sushi ..... 88  
Refrigerated display cases for bottles and accessories ..... 89  
Refrigerated display cases ..... 90-94

**Sanitation 95-96**  
Sink with knee switch ..... 95  
Water softener ..... 95  
Waste shredders ..... 96

**Pots and saucepans**

- DE Töpfe und Stielkasserolen  
RU Кастрюли и сотейники  
UK Каструлі і сковороди  
LT Puodai ir prikaistuviai  
LV Katli un kastroļi  
CS Hrnce a pánve  
SK Hrnca a kastroly  
HU Edények és serpenyők  
RO Oale și tigăi pentru sos
- ES Ollas y sartenes  
FR Pots et casseroles  
PT Panelas e frigideiras  
IT Pentole e tegami  
BG Тенджери и касероли  
EL Κατσαρόλες και κατσαρόλακια  
ZT 不锈钢带盖汤锅

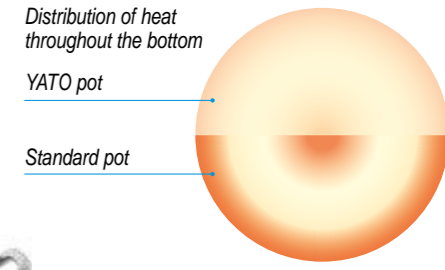
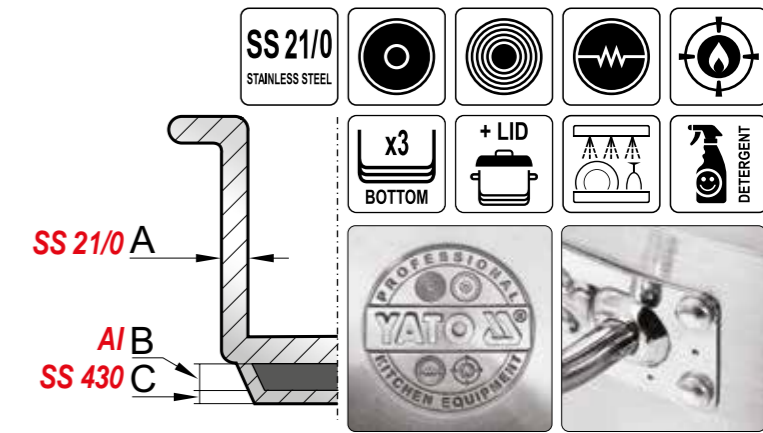

**Deep pots with lids**

YATO	Ø (cm)	H (cm)	V (l)	A (mm)	B (mm)	C (mm)
YG-00001	16	12	2.4	0.8	4.0	0.8
YG-00002	20	20	6.3	0.8	4.0	0.8
YG-00003	24	20	9.0	0.8	4.0	0.8
YG-00004	28	25	15.4	0.8	4.0	0.8
YG-00005	32	26	20.9	1.0	4.0	0.8
YG-00006	32	32	25.7	1.0	4.0	0.8
YG-00007	36	36	36.6	1.0	4.0	0.8
YG-00008	40	40	50.3	1.0	4.0	1.0
YG-00009	45	45	71.6	1.2	4.0	1.0
YG-00010	50	50	98.2	1.2	4.0	1.0

**Medium pots with lids**

YATO	Ø (cm)	H (cm)	V (l)	A (mm)	B (mm)	C (mm)
YG-00021	16	9.5	1.9	0.8	4.0	0.8
YG-00022	20	14	4.4	0.8	4.0	0.8
YG-00023	24	16	7.2	0.8	4.0	0.8
YG-00024	28	18	11.1	0.8	4.0	0.8
YG-00025	32	20	16.1	1.0	4.0	0.8
YG-00026	36	22	22.4	1.0	4.0	0.8
YG-00027	40	30	37.7	1.0	4.0	1.0
YG-00028	45	36	57.3	1.2	4.0	1.0
YG-00029	50	32	62.8	1.2	4.0	1.0

**Low pots with lids**

YATO	Ø (cm)	H (cm)	V (l)	A (mm)	B (mm)	C (mm)
YG-00040	20	10.5	3.3	0.8	4.0	0.8
YG-00041	24	11	5.0	0.8	4.0	0.8
YG-00042	28	13	8.0	0.8	4.0	0.8
YG-00043	32	16	12.9	1.0	4.0	0.8
YG-00044	36	18	18.3	1.0	4.0	0.8
YG-00045	40	25	31.4	1.0	4.0	1.0



**Stewing pot with lid**

YATO	Ø (cm)	H (cm)	V (l)	A (mm)	B (mm)	C (mm)
YG-00055	36	11	11.2	1.0	4.0	0.8

**Pans with lids**

YATO	Ø (cm)	H (cm)	V (l)	A (mm)	B (mm)	C (mm)
YG-00060	16	9.5	1.9	0.8	4.0	0.8
YG-00061	20	10.5	3.3	0.8	4.0	0.8
YG-00062	24	11	5	0.8	4.0	0.8
YG-00063	28	13	8	0.8	4.0	0.8

**Saucepans**

YATO	Ø (cm)	H (cm)	V (l)	A (mm)	B (mm)	C (mm)
YG-00080	20	6.5	2	0.8	4.0	0.8
YG-00081	24	7.5	3.4	0.8	4.0	0.8

### Pots with lids

- DE Töpfe mit Deckel
  - RU Горшки с крышками
  - UK Горщики з кришками
  - LT Puodai su dangčiais
  - LV Podi ar vākiem
  - CS Hrnce s víčky
  - SK Hrnce s pokrievkami
  - HU Fedeles edények
  - RO Ghivece cu capace
- ES Ollas con tapa
  - FR Pots avec couvercles
  - PT Potes com tampa
  - IT Pentole con coperchio
  - BG Саксии с капащи
  - EL Γλάστρες με καπάκια
  - ZT 帶蓋花盆

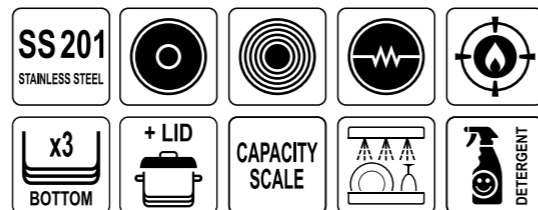

Distribution of heat throughout the bottom

YATO pot

Standard pot

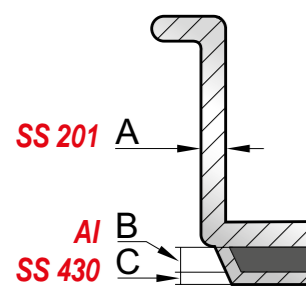
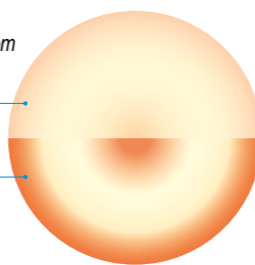

### Deep pots with lids

YATO 	∅ (cm)	H (cm)	V (l)	A (mm)	B (mm)	C (mm)
YG-00011	20	20	6	1.0	4.0	0.8
YG-00012	25	25	12	1.0	4.0	0.8
YG-00013	28	28	17	1.0	4.0	0.8
YG-00014	30	30	21	1.0	4.0	0.8
YG-00015	32	32	25	1.0	4.0	0.8
YG-00016	36	36	36	1.0	4.0	0.8
YG-00017	38	38	43	1.0	4.0	0.8
YG-00018	40	40	50	1.0	4.0	0.8
YG-00019	45	45	71	1.2	4.0	1.0
YG-00020	50	50	98	1.2	4.0	1.0

### Medium pots with lids

YATO 	∅ (cm)	H (cm)	V (l)	A (mm)	B (mm)	C (mm)
YG-00046	25	18	9	1.0	4.0	0.8
YG-00047	30	20	14	1.0	4.0	0.8
YG-00048	32	22	17	1.0	4.0	0.8
YG-00049	36	24	24	1.0	4.0	0.8
YG-00050	38	24	27	1.0	4.0	0.8
YG-00051	40	26	32	1.0	4.0	0.8
YG-00052	50	30	58	1.2	4.0	1.0

### Stainless steel frying pans

- DE Pfannen aus rostfreiem Edelstahl
- RU Стальные сковороды
- UK Каструлі з нержавіючої сталі
- LT Nerūdijančio plieno keptuvės
- LV Nerūsējošā tērauda pannas
- CS Pánve z nerezoucí oceli
- SK Panvice z nehrdzavejúcej ocele
- HU Rozsdamentes acélból készült serpenyők
- RO Tigăi din oțel inoxidabil
- ES Sartenes de acero inoxidable
- FR Casseroles en acier inoxydable
- PT Panelas de aço inoxidável
- IT Padelle in acciaio inossidabile
- BG Тигани от неръждаема стомана
- EL Τηγάνια από ανοξείδωτο ατσάλι
- ZH 不锈钢平底煎锅

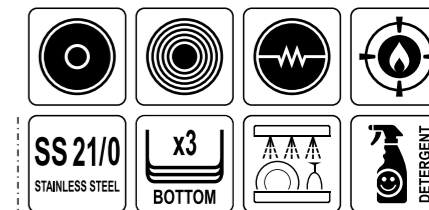

Distribution of heat throughout the bottom

YATO frying pan

Standard frying pan

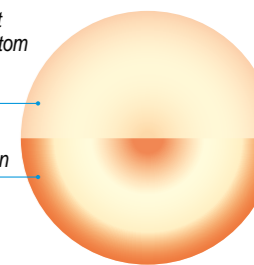
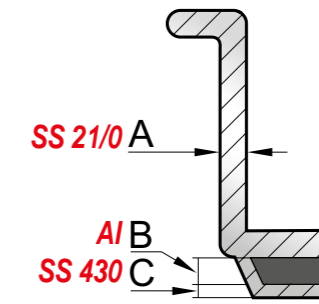

YATO 	∅ (cm)	H (cm)	V (l)	A (mm)	B (mm)	C (mm)
YG-00100	20	4	1.3	0.8	4.0	0.8
YG-00101	24	5	2.3	0.8	4.0	0.8
YG-00102	28	5	3.1	0.8	4.0	0.8



YATO 	∅ (cm)	H (cm)	V (l)	A (mm)	B (mm)	C (mm)
YG-00103	32	5	4	1.0	4.0	0.8
YG-00104	36	6	6.1	1.0	4.0	0.8
YG-00105	40	7	8.8	1.0	4.0	0.8

### Aluminium frying pans with Teflon™ Platinum Plus coating

- |                          |                          |
|--------------------------|--------------------------|
| DE Aluminiumpfannen      | ES Bandejas de aluminio  |
| RU Алюминиевые сковороды | FR Plateaux en aluminium |
| UK Алюмінієві каструлі   | PT Panelas de alumínio   |
| LT Aliuminio keptuvės    | IT Padelle in alluminio  |
| LV Alumīnija pannas      | BG Алюминиеви тигани     |
| CS Hliníkové pánve       | EL Τηγάνια αλουμινίου    |
| SK Hliníkové panvice     | ZH 涂层铝制煎锅                |
| HU Alumínium serpenyők   |                          |
| RO Tigăi profesionale    |                          |

The Teflon™ Platinum Plus coating is capable of withstanding even the hardest challenges in gastronomy. It contains microscopic particles of the hardest minerals that form an extraordinarily resilient structure. It is so durable that you can even use metal spatulas while frying without worrying about any significant scratches. Additionally, the body of the pan is made of cast aluminium, which ensures homogeneous and quick heating.

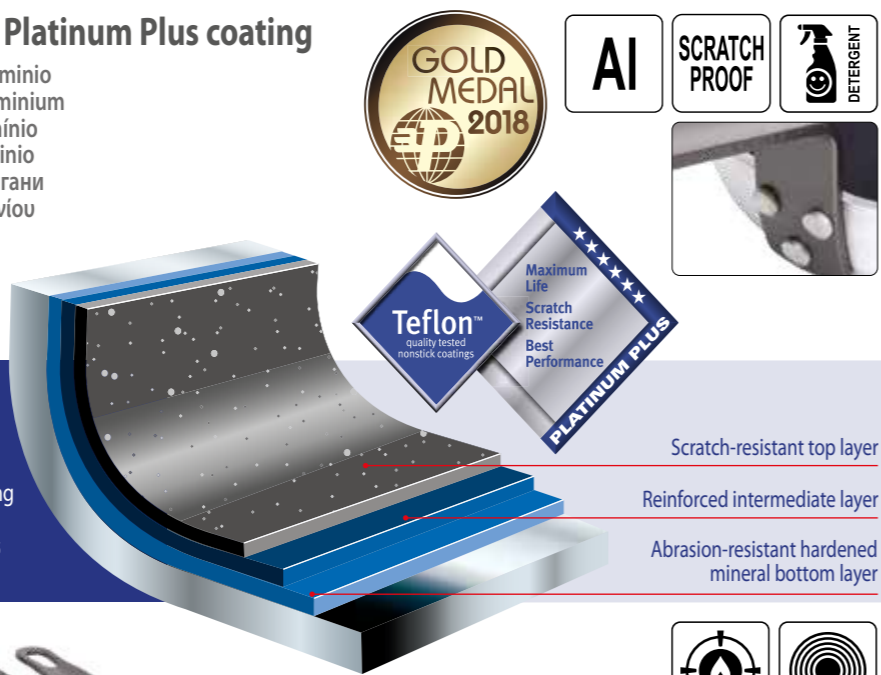

### Universal frying pans

YATO 	Ø (cm)*
YG-00131	24
YG-00132	28
YG-00133	32



### Frying pans for pancakes

YATO 	Ø (cm)*
YG-00152	26
YG-00153	29



### Frying pan for fish

YATO 	Ø (cm)*
YG-00155	29 x 40



### Frying pans placed on induction hob

YATO 	Ø (cm)*
YG-00160	24
YG-00161	28

\* external diameter



Scratch-resistant top layer  
Reinforced intermediate layer  
Abrasion-resistant hardened mineral bottom layer

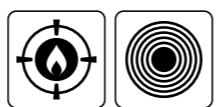

### Stainless steel GN containers

- |  |
|--|
| DE Behälter GN aus rostfreiem Edelstahl      |
| RU Гастроёмкости GN из нержавеющей стали     |
| UK Контейнери GN з нержавіючої сталі         |
| LT Nerūdijančio plieno GN indas              |
| LV Nerūsējošā tērauda GN trauki              |
| CS Nádoby GN z nerezovací oceli              |
| SK GN nádoby z nehrdzavejúcej ocele          |
| HU Rozsdamentes acélból készült GN tartályok |
| RO Containere GN din oțel inoxidabil         |
| ES Contenedores GN de acero inoxidable       |
| FR Récipients GN en acier inoxydable         |
| PT Recipientes GN em aço inoxidável          |
| IT Contenitore GN di acciaio inossidabile    |
| BG GN контейнери от неръждаема стомана       |
| EL Δοχεία GN από ανοξείδωτο ασάλι            |
| ZH 不锈钢份数盘                                    |

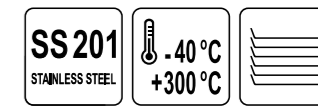

1/1	2/3
1/2	1/3
1/4	1/4
1/6	1/6
1/9	1/9

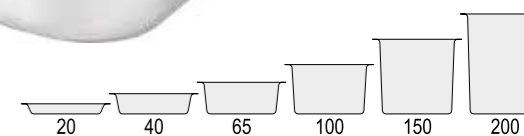

#### GN 1/1 – 530 x 325 mm

YATO 	H (mm)	V (l)
YG-00250	20	3.0
YG-00251	40	6.0
YG-00252	65	8.5
YG-00253	100	13.5
YG-00254	150	20.5
YG-00255	200	26.0

#### GN 2/3 – 354 x 325 mm

YATO 	H (mm)	V (l)
YG-00302	65	6.5
YG-00303	100	9.0
YG-00304	150	13.0

#### GN 1/2 – 325 x 265 mm

YATO 	H (mm)	V (l)
YG-00260	20	2.0
YG-00261	40	4.0
YG-00262	65	4.5
YG-00263	100	7.0
YG-00264	150	10.0
YG-00265	200	12.5

#### GN 1/3 – 325 x 176 mm

YATO 	H (mm)	V (l)
YG-00270	20	0.8
YG-00271	40	1.5
YG-00272	65	2.5
YG-00273	100	4.0
YG-00274	150	6.0



#### GN 1/4 – 265 x 162 mm

YATO 	H (mm)	V (l)
YG-00282	65	1.8
YG-00283	100	3.0
YG-00284	150	4.5



#### GN 1/6 – 176 x 162 mm

YATO 	H (mm)	V (l)
YG-00290	65	1.0
YG-00291	100	1.7
YG-00292	150	2.5
YG-00293	200	3.4

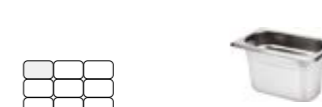

#### GN 1/9 – 176 x 108 mm

YATO 	H (mm)	V (l)
YG-00295	65	0.6
YG-00296	100	1.0



Container size designation in the corner



#### GN 1/1 – 530 x 325 mm perforated

YATO 	H (mm)	V (l)
YG-00340	20	3.0
YG-00341	40	6.0
YG-00342	65	8.5
YG-00343	100	13.5
YG-00344	150	20.5
YG-00345	200	26.0



#### GN 2/3 – 354 x 325 mm perforated

YATO 	H (mm)	V (l)
YG-00360	65	6.5
YG-00361	100	9.0



#### GN 1/2 – 325 x 265 mm perforated

YATO 	H (mm)	V (l)
YG-00355	65	4.5
YG-00356	100	7.0
YG-00357	150	10.0

#### Stainless steel lids for GN containers

YATO 	FOR:
YG-00370	GN 1/1
YG-00371	GN 1/2
YG-00372	GN 1/3
YG-00373	GN 1/4
YG-00374	GN 1/6
YG-00375	GN 1/9
YG-00377	GN 2/3

### Polycarbonate GN containers

DE Behälter GN aus Polycarbonat  
RU Гастроёмкости GN из поликарбоната  
UK Контейнери GN з полікарбонату  
LT Polikarbonato GN indas  
LV Poliābonāta GN trauki  
CS Nádoby GN z polykarbonátu  
SK GN nádoby z polykarbonátu  
HU Polikarbonát GN tartályok  
RO Containere GN din policarbonat  
ES Contenedores GN de policarbonato  
FR Récipients GN en polycarbonate  
PT Recipientes GN em policarbonato  
IT Contenitore GN in policarbonato  
BG GN контейнери от поликарбонат  
EL Δοχεία GN από πολυανθρακικό  
ZH 聚碳酸酯份数盆

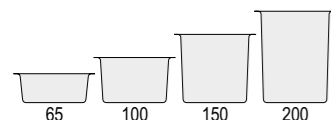
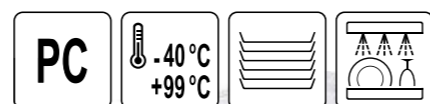

GN 1/1 – 530 x 325 mm

YATO	H (mm)	V (l)
YG-00390	65	8.5
YG-00391	100	13.0
YG-00392	150	19.5
YG-00393	200	25.6

GN 1/2 – 325 x 265 mm

YATO	H (mm)	V (l)
YG-00400	65	3.9
YG-00401	100	5.9
YG-00402	150	8.9
YG-00403	200	11.7

Polycarbonate lids for GN containers

YATO	FOR:
YG-00434	GN 1/1
YG-00435	GN 1/2
YG-00436	GN 1/3
YG-00437	GN 1/4
YG-00438	GN 1/6
YG-00439	GN 1/9

GN 1/3 – 325 x 176 mm

YATO	H (mm)	V (l)
YG-00410	65	2.4
YG-00411	100	3.6
YG-00412	150	5.3
YG-00413	200	6.9

GN 1/4 – 265 x 162 mm

YATO	H (mm)	V (l)
YG-00419	65	1.7
YG-00420	100	2.5
YG-00421	150	3.7

GN 1/6 – 176 x 162 mm

YATO	H (mm)	V (l)
YG-00425	65	1.0
YG-00426	100	1.5
YG-00427	150	2.2

GN 1/9 – 176 x 108 mm

YATO	H (mm)	V (l)
YG-00430	65	0.57
YG-00431	100	0.85

Polycarbonate drain shelves for GN containers

YATO	FOR:
YG-00460	GN 1/1
YG-00461	GN 1/2
YG-00462	GN 1/3
YG-00463	GN 1/4
YG-00464	GN 1/6

### Buckets

DE Eimer  
RU Ведро  
UK Відра  
LT Kibirai  
LV Kausi  
CS Kbelíky  
SK Vedrá  
HU Vödörök  
RO Cupe  
ES Cubos  
FR Seaux  
PT Baldes  
IT Secchi  
BG Кофи  
EL Κουβάδες  
ZH 水桶

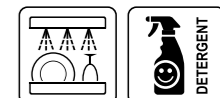

YATO	V (l)	Ø (cm)	H (cm)
YG-00650	12	25/24	27
YG-00651	16	30/25	30
YG-00652	28	35/30	35

### Scale jugs

DE Messbecher  
RU Мерные кувшины  
UK Глечики з мірками  
LT Asočiai su matavimo skale  
LV Mērkrūzes  
CS Džbány s měrkou  
SK Džbany s mierkou  
HU Mérókanna

RO Căni de măsură  
ES Jarra medidora  
FR Cruche à mesurer  
PT Jarros de medição  
IT Brocca con misurino  
BG Кани с деления  
EL Κανάτα με μέτρο  
ZH 量壶



YATO	V (l)	Ø (mm)	H (mm)
YG-07282	0.5	90	135
YG-07284	1	115	165
YG-07286	2	150	205
YG-07287	3	170	230
YG-07288	5	195	270



### Container for cutlery

DE Besteckbehälter  
RU Емкость для столовых приборов  
UK Контейнер для столових приборів  
LT Stalo įrankių padėklas  
LV Galda piederumu trauki  
CS Nádoby na příbory  
SK Nádoby na príbor  
HU Evőeszköz tartó  
RO Organizator pentru tacâmuri

ES Cubertero  
FR Range-couverts  
PT Recipiente para talheres  
IT Contenitore per posate  
BG Контейнер за прибори  
EL Δοχείο για μαχαιροπήρουνα  
ZH 4格餐具收納盒

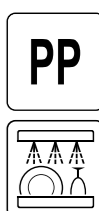

YATO	(mm)
YG-02665	520 x 290 x 95



### Food storage containers

DE Behälter zur Aufbewahrung von Lebensmitteln  
RU Контейнеры для хранения пищевых продуктов  
UK Контейнери для зберігання продуктів харчування  
LT Maisto saugojimo indai  
LV Pārtikas uzglabāšanas trauki  
CS Nádoby k uchování potravin  
SK Nádoby na uschovávanie potravín  
HU Ételtároló tartályok  
RO Containere pentru depozitarea alimentelor  
ES Contenedores para el almacenamiento de alimentos  
FR Récipients pour le stockage des aliments  
PT Recipientes para armazenamento de alimentos  
IT Contenitore per la conservazione di alimenti  
BG Контейнери за съхранение на храни  
EL Δοχεία αποθήκευσης τροφίμων  
ZH 圆形食品储物桶



### Round containers

YATO	V (l)	Ø (mm)	H (mm)
YG-00510	1	128	120
YG-00511	2	183	110
YG-00512	4	183	210
YG-00513	6	222	200
YG-00514	7.5	222	270
YG-00515	10	310	210
YG-00516	15	310	300
YG-00517	20	310	370

PP



### Covers for round containers

YATO	Ø (mm)	FOR:
YG-00518	132	YG-00510
YG-00519	187	YG-00511, YG-00512
YG-00520	226	YG-00513, YG-00514
YG-00521	316	YG-00515, YG-00516, YG-00517

PE

### Square containers

YATO	V (l)	(mm)	H (mm)
YG-00522	6	222 x 222	185
YG-00524	22	280 x 280	400

PC



PE

### Cover for square containers

YATO	(mm)	FOR:
YG-00526	293 x 293	YG-00524

### Kettle paddle

DE Rührpaddel für Kessel  
RU Мешалка для котла  
UK Мішалка для котла  
LT Maišytuvės katilui  
LV Maisītājs katlam  
CS Míchadlo do kotle  
SK Miešadlo pre kotol  
HU Keverő lapát  
RO Paletă pentru amestecat  
ES Agitador de caldera  
FR Agitateur de chaudière cuisine  
PT Agitador para caldeiras  
IT Spatola lunga  
BG Бъркалка за тенджеря  
EL Αναδευτήρας λέβητα  
ZH 不锈钢打蛋器

SS 18/8  
STAINLESS STEEL

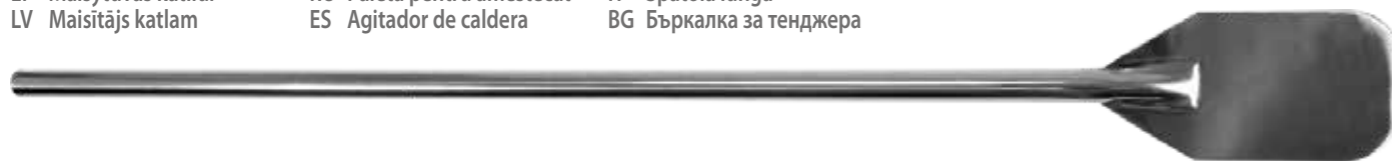

YATO	L (mm)
YG-02520	1220

### Container for bulk products

DE Behälter für lose Produkte  
RU Контейнер для сыпучих продуктов  
UK Контейнер для сипучих продуктів  
LT Palaidų produktų indas  
LV Trauks beramiem produktiem  
CS Nádoby na sypké materiály  
SK Nádoby na sypké produkty  
HU Tartály szórt termékekhez  
RO Container pentru produse vrac  
ES Contenedor para productos a granel  
FR Récipient pour produits en vrac  
PT Recipiente para produtos soltos  
IT Contenitore per prodotti sfusi  
BG Контейнер за насипни продукти  
EL Δοχείο για χύμα προϊόντα  
ZH 食物配料儲存桶



81L  
CAPACITY  
PP/PC  
77kg SUGAR  
63kg FLOUR  
CAPACITY  
360°  
2x

YATO	V (l)	(mm)
YG-09109	81	760 x 330 x 740

### Polycarbonate scoops

DE Schaufeln aus Polycarbonat  
RU Совки из поликарбоната  
UK Совки з полікарбонату  
LT Polikarbonato semtuvėlis šiukšlėms  
LV Polikarbonāta lāpstiņas  
CS Naběračky z polykarbonátu  
SK Lopatky z polykarbonátu  
HU Polikarbonát lapát  
RO Scafe din policarbonat  
ES Paletas de policarbonato  
FR Spatule en polycarbonate  
PT Colheres de policarbonato  
IT Palette in policarbonato  
BG Лопатки от поликарбонат  
EL Πολυκαρβονικά φαράσια  
ZH PC冰铲

PC

-40°C  
+99°C

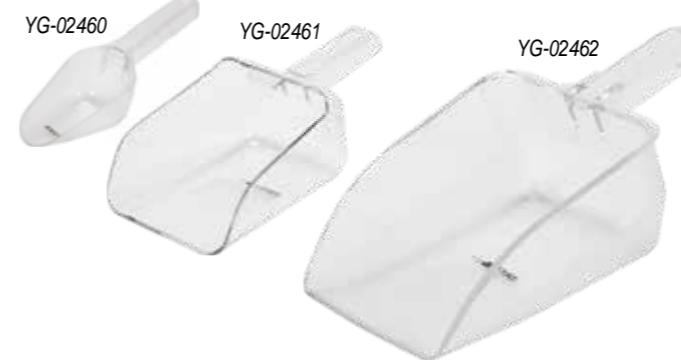

YATO	V (l)	(mm)
YG-02460	0.18	220 x 185
YG-02461	0.95	280 x 210
YG-02462	1.9	280 x 400

### Aluminium scoops

DE Aluminiumschaufeln  
RU Алюминиевые совки  
UK Алюмінієві совки  
LT Aliuminio semtuvėlis šiukšlėms  
LV Alumīnija lāpstiņas  
CS Hliníkové naběračky  
SK Hliníkové lopatky  
HU Alumínium lapát  
RO Scafe din aluminiu  
ES Paletas de aluminio  
FR Spatule en aluminium  
PT Colheres de alumínio  
IT Palette in alluminio  
BG Алуминиеви лопатки  
EL Φαράσια αλουμινίου  
ZH 铝冰铲

Al



YATO	V (l)	L (mm)
YG-02450	0.15	185
YG-02451	0.35	220
YG-02452	0.7	270
YG-02453	1.7	380

### Forged steel knives

- |                             |                               |                                      |
|-----------------------------|-------------------------------|--------------------------------------|
| DE Messer aus Schmiedestahl | SK Nož z kovanej ocele        | IT Coltelli in acciaio forgiato      |
| RU Ножи из кованой стали    | HU Kovácsolt acél kés         | BG Ножове от кована стомана          |
| UK Ножи з кованої сталі     | RO Cuțite din oțel forjat     | EL Μαχαίρια από σφυρηλατημένο χάλυβα |
| LT Kaltinio plieno peiliai  | ES Cuchillos de acero forjado | ZH 西厨刀                               |
| LV Kaltā tērauda naži       | FR Couteaux en acier forgé    |                                      |
| CS Nože z kované oceli      | PT Facas de aço forjado       |                                      |



Knife blade side surface is used to carry chopped herbs and onion and to flatten fillets and steaks

Thick back of the knife can be used to break tiny bones and to open shells in shellfish

Knife blade heel is excellent for cutting small vegetables, for example garlic or radish

Blade middle can be used to cut broad food products and to chop

Bottom blade part, as it produces the greatest pressure force, is used to cut exceptionally hard food products

Rounds near the handle prevent from palm slipping on the blade

### Chef's knives

YATO	L (mm)
YG-02230	205 / 340
YG-02231	255 / 395



### Butcher knife

YATO	L (mm)
YG-02229	205 / 340



### Ham knife

YATO	L (mm)
YG-02232	290 / 425



### Boning knife

YATO	L (mm)
YG-02224	160 / 290



### Bread knife

YATO	L (mm)
YG-02223	205 / 340



### Tomato knife

YATO	L (mm)
YG-02227	140 / 245



### Paring knives

YATO	L (mm)
YG-02225	90 / 195
YG-02226	90 / 196



### Meat fork

YATO	L (mm)
YG-02216	180 / 310

### Kitchen scissors

- |                        |                      |                              |                      |
|------------------------|----------------------|------------------------------|----------------------|
| DE Küchenschere        | LV Virtuves naži     | RO Foarfeci pentru bucătărie | IT Forbici da cucina |
| RU Кухонные ножницы    | CS Kuchyňské nůžky   | ES Tijeras de cocina         | BG Кухненски ножници |
| UK Кухонні ножці       | SK Kuchynské nožnice | FR Ciseaux de cuisine        | EL Ψαλίδια κουζίνας  |
| LT Virtuviniai peiliai | HU Konyhai ollók     | PT Tesouras de cozinha       | ZH 厨房剪刀              |

SS2CR13

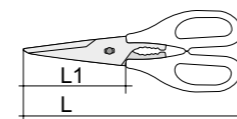

Blade thickness: 1.8 mm

YATO	L (mm)	L1 (mm)
YG-02365	210	80

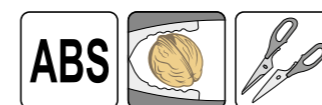

Blade thickness: 3 mm

YATO	L (mm)	L1 (mm)
YG-02366	210	70

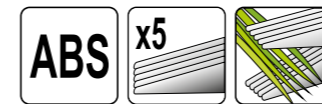
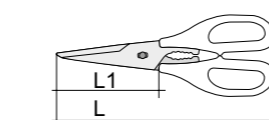

Blade thickness: 1.2 mm

YATO	L (mm)	L1 (mm)
YG-02368	200	80



### Steel for knife sharpening

- |                               |                                   |                                  |
|-------------------------------|-----------------------------------|----------------------------------|
| DE Stahlmesserschärfer        | SK Ocelová brúška na nože         | IT Affilcoltelli in acciaio      |
| RU Точилка для ножей из стали | HU Acél késélező                  | BG Точилка за ножове             |
| UK Stahlmesserschärfer        | RO Ascuțitor pentru oțel          | EL Ξύστρα για μαχαίρι από χάλυβα |
| LT Plieninis peilių gaštuvus  | ES Afilador de cuchillos de acero | ZH 钢磨刀器                          |
| LV Tērauda nažu asinātājs     | FR Aiguiseur de couteaux en acier |                                  |
| CS Ořezávkó ocelového nože    | PT Afiador de facas de aço        |                                  |

SS  
STAINLESS STEEL

PP



YATO	L (mm)
YG-02214	200 / 320



### Knife and scissor sharpeners

- |  |  |   |                                       |
|--|--|---|---------------------------------------|
| DE Scheren- und Messerschärfer             | CS Ostrůtko na nože a nůžky                      | ES Afiladoras de cuchillos y tijeras      | EL Ακονιστήρια μαχαιριών και ψαλιδιών |
| RU Точилки для ножей и ножиц               | SK Nástroje na ostrenie nožov a nožnic           | FR Aiguilleurs à couteaux et ciseaux      |                                       |
| UK Пристрій для заточування ножів і ножиць | HU Kés- és ollóélező                             | PT Afiadores de facas e tesouras          | ZH 磨刀器                                |
| LT Peilių ir žirklių galastuvai            | RO Dispozitive pentru ascuțit cuțite și foarfeci | IT Affilatrice per coltelli e forbici     |                                       |
| LV Nažu un šķēru asināmie                  |  | BG Точила за заточване на ножове и ножици |                                       |

#### 3-function sharpener for steel and ceramic knives



**YATO**  
YG-02351

EASY CLEAN

- 3 in 1**
- CERAMIC BLADE
- DIAMOND BLADE
- TUNGSTEN STEEL BLADE
- FOR CERAMIC KNIVES
- FOR METAL KNIVES
- NON-SLIP BASE

#### 2-function sharpener for ceramic and steel knives



**YATO**  
YG-02353

- 2 in 1**
- CERAMIC BLADE
- DIAMOND BLADE
- FOR CERAMIC KNIVES
- FOR METAL KNIVES
- NON-SLIP BASE

#### 4-function sharpener for scissors, smooth metal knives and ceramic knives



**YATO**  
YG-02352



NON-SLIP BASE

- 4 in 1**
- DIAMOND BLADE
- CERAMIC BLADE
- TUNGSTEN STEEL BLADE
- FOR CERAMIC KNIVES
- FOR METAL KNIVES
- FOR SCISSORS

#### Compact sharpener for smooth metal knives



**YATO**  
YG-02354



NON-SLIP BASE

- 2 in 1**
- CERAMIC BLADE
- FOR METAL KNIVES
- TUNGSTEN STEEL BLADE

### Can opener

- |                          |                           |
|--------------------------|---------------------------|
| DE Dosenöffner           | RU Консервный нож         |
| UK Відкривачка для банок | LT Skardinių atidarytuvas |
| LV Bundžu attaisāmais    | CS Otvírák na konzervy    |
| SK Otvárač na konzervy   | HU Konzervnyitó           |
| RO Desfăcător conserve   | ES Abrelatas              |
| FR Ouvre-boîte           | PT Abridor de latas       |
| IT Apriscatole           | BG Отварачка за консерви  |
| EL Ανοιχτήρι κονσερβών   | ZH 开罐器                    |



<b>YATO</b>	∅ (mm)
YG-02430	355



∅ max  
**355mm**  
CAN

H max  
**310mm**  
CAN

### Chopping boards

- |                       |                      |                        |                    |
|-----------------------|----------------------|------------------------|--------------------|
| DE Schneidebretter    | LV Griešanas dēļi    | RO Tocătoare           | IT Tagliere        |
| RU Разделочные доски  | CS Krájecí deska     | ES Tablas para cortar  | BG Дъски за рязане |
| UK Обробні дошки      | SK Dosky na krájanie | FR Planches à découper | EL Σανίδες κοπής   |
| LT Pjaustymo lentelės | HU Vágódeszkák       | PT Tábuas de cortar    | ZH 砧板              |



#### Chopping boards with a handle

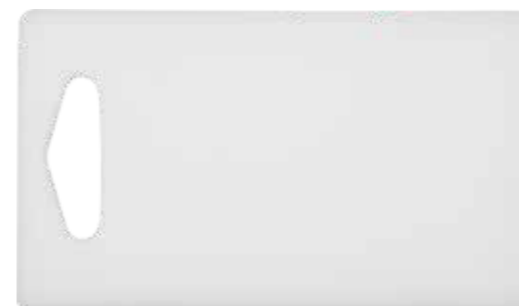

<b>YATO</b>	(mm)
YG-02150	250 x 150 x 10
YG-02153	300 x 220 x 10

#### Chopping boards compliant with HACCP colour coding

<b>YATO</b>	(mm)	COLOUR
YG-02170	450 x 300 x 13	●
YG-02171	450 x 300 x 13	●
YG-02172	450 x 300 x 13	●
YG-02173	450 x 300 x 13	●
YG-02174	450 x 300 x 13	○
YG-02175	450 x 300 x 13	●
YG-02180	600 x 400 x 20	●
YG-02181	600 x 400 x 20	●
YG-02182	600 x 400 x 20	●
YG-02183	600 x 400 x 20	●
YG-02184	600 x 400 x 20	○
YG-02185	600 x 400 x 20	●

#### Chopping boards with rubber feet



**x6**  
RUBBER FEET

<b>YATO</b>	(mm)
YG-02160	350 x 250 x 20
YG-02163	440 x 290 x 20
YG-02166	500 x 340 x 20
YG-02168	600 x 390 x 20

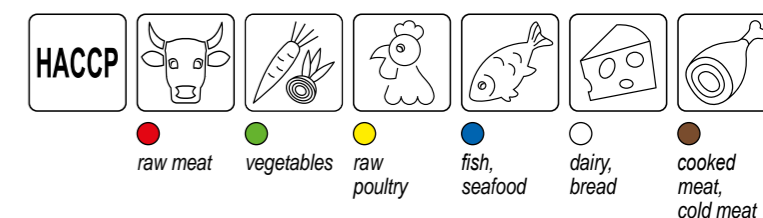

### Chopping board scraper

- |  |                                     |
|--|-------------------------------------|
| DE Schneidebrett-Schaber                 | ES Rascador para tablas de corte    |
| RU Рубанок для очистки разделочных досок | FR Racloir pour planches à découper |
| UK Скребок для обробних дощок            | PT Raspador para tábuas de cortar   |
| LT Pjaustymo lentelių grandiklis         | IT Raschietto per tagliere          |
| LV Skrāpis griešanas dēļiem              | BG Ренде за дъски за рязане         |
| CS Škrabka na krájecí desku              | EL Ξέστρο για σανίδες κοπής         |
| SK Škrabka pre dosky na krájanie         | ZH 砧板刮                              |
| HU Vágódeszka kaparó                     |                                     |
| RO Răzuitoare pentru tocătoare           |                                     |

FOR:  
**PE**



<b>YATO</b>	(mm)
YG-02188	220 x 100 x 50

### Rods

- |                        |                        |                     |
|------------------------|------------------------|---------------------|
| DE Schneebesens        | SK Mieltičky           | IT Frusta da cucina |
| RU Шампуры             | HU Habverők            | BG Тел за разбиване |
| UK Пізки               | RO Teluri              | EL Αβγοδάρτες       |
| LT Rankiniai plaktuvai | ES Varillas para batir | ZH 棒                |
| LV Putojamās slotiņas  | FR Fouets              |                     |
| CS Metly               | PT Batedores           |                     |



**SS 18/8**  
STAINLESS STEEL

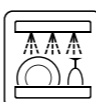

YATO	L (mm)
YG-02510	300
YG-02511	400
YG-02512	500
YG-02513	600

### Narrow spatulas

- |                                |                                  |
|--------------------------------|----------------------------------|
| DE Schmale Tortenstreichspatel | ES Espátulas de cocina estrechas |
| RU Узкие шпатели               | FR Spatules de cuisine étroites  |
| UK Вузькі шпатели              | PT Espátulas estreitas           |
| LT Šiaura mentelė              | IT Spatole strette               |
| LV Šauras lāpstiņas            | BG Тесни шпатули                 |
| CS Úzké špachtle               | EL Στενές σπαθίδες               |
| SK Špachtle úzke               | ZH 不锈钢铲                          |
| HU Keskeny spatulák            |                                  |
| RO Spatulă înguste             |                                  |



**SS**  
STAINLESS STEEL



### Narrow straight spatulas

YATO	(mm)
YG-02408	120 / 225
YG-02409	205 / 335
YG-02410	255 / 385
YG-02411	310 / 440
YG-02412	355 / 485

### Narrow angled spatulas

YATO	(mm)
YG-02415	255 / 385
YG-02416	300 / 430

### Universal tongs

- |                          |
|--------------------------|
| DE Universalzangen       |
| RU Универсальные щипцы   |
| UK Універсальні щипці    |
| LT Universaliūs žnyplės  |
| LV Universālas stangas   |
| CS Univerzální kleště    |
| SK Univerzálna kliešte   |
| HU Univerzális fogók     |
| RO Clești universali     |
| ES Alicates multiusos    |
| FR Pince multi-usages    |
| PT Alicates universais   |
| IT Pinze universali      |
| BG Универсални щипки     |
| EL Λαβίδα γενικής χρήσης |
| ZH 不锈钢夹                  |



**SS 18/8**  
STAINLESS STEEL

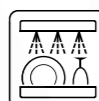

YATO	L (mm)
YG-02750	240
YG-02751	300
YG-02752	400

### Colander spoons

- |                       |
|-----------------------|
| DE Schaumlöffel       |
| RU Шумовки            |
| UK Друшляки           |
| LT Kiaurasamčiai      |
| LV Putu karotes       |
| CS Dírkované lžíce    |
| SK Zberáčky           |
| HU Csepegtető kanálok |
| RO Spumiere           |
| ES Cucharas coladoras |
| FR Araignées          |
| PT Escumadeiras       |
| IT Schiumarola        |
| BG Решетъчни лъжици   |
| EL Τρυπητές κουτάλες  |
| ZH 不锈钢漏勺              |



**SS 18/8**  
STAINLESS STEEL



YATO	Ø (mm)	L (mm)
YG-02593	120	475
YG-02595	140	570
YG-02598	160	580



### Colander spoons and sieves

- |                                   |                                     |
|-----------------------------------|-------------------------------------|
| DE Schaumlöffel und Siebe         | PT Escumadeiras e peneiras          |
| RU Шумовки и сита                 | IT Schiumarola e setaccio           |
| UK Друшляки і сита                | BG Решетъчни лъжици и цедки         |
| LT Kiaurasamčiai ir sieteliai     | EL Τρυπητές κουτάλες και σουρωτήρια |
| LV Putu karotes un sieti          | ZH 漏勺和筛子                            |
| CS Dírkované lžíce a síta         |                                     |
| SK Zberáčky a sitká               |                                     |
| HU Csepegtető kanálok és sziták   |                                     |
| RO Strecurătoare și site          |                                     |
| ES Cucharas coladoras y coladores |                                     |
| FR Araignées et passoires         |                                     |

### Colander spoons with a rim

YATO	Ø (mm)	L (mm)
YG-00600	220	600
YG-00601	260	730



**SS 18/8**  
STAINLESS STEEL

**HANGABLE**

**FINE MESH**



Mesh density: 2 x 2 mm

**LARGE MESH**

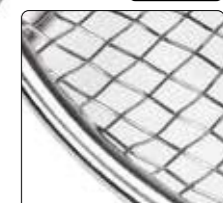

Mesh density: 5 x 5 mm

### Colander spoons

YATO	Ø (mm)	L (mm)
YG-00602	155	470
YG-00603	200	510



**FINE MESH**



Mesh density: 0.5 x 0.5 mm

### Thick mesh chinois

YATO	Ø (mm)	L (mm)
YG-00605	120	310
YG-00606	160	350

### Sieves for sifting

YATO	Ø (mm)	H (mm)
YG-00615	220	60
YG-00617	280	70



**FINE MESH**

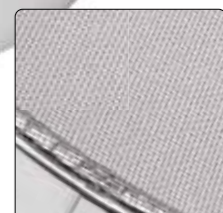

Mesh density: 1 x 1 mm



### Pizza meshes

- DE Pizza-Gitter
- RU Сетки для пиццы
- UK Сітки для піци
- LT Picų tinklai
- LV Sieti picai
- CS Sítky na pizzu
- SK Siete na pizzu
- HU Pizzarácsok
- RO Tăvi sită pentru pizza
- ES Rejillas para la pizza
- FR Tamis à pizza
- PT Telas de pizza
- IT Rete per pizza
- BG Решетки за пица
- EL Κόσκινα για pizza
- ZH 披萨网筛



AI

Mesh density: 4 x 5 mm



YATO	Ø (mm)	Ø INSIDE (mm)
YG-02030	230	210
YG-02031	280	260
YG-02032	300	280
YG-02033	330	310
YG-02034	350	330
YG-02035	380	360
YG-02036	400	380
YG-02037	450	430
YG-02038	500	480

### Condiment dispensers

- DE Spender für kalte Soßen
- RU Диспенсеры для холодных соусов
- UK Диспенсери для холодних соусів
- LT Šaltų padažų dalytuvai
- LV Austo mērču dispenseri
- CS Dávkořač na studené omáčky
- SK Dispenzér na studené omáčky
- HU Hideg szósz adagoló
- RO Dispenser pentru sosuri
- ES Dispensadores de salsa fría
- FR Distributeurs de sauce froide
- PT Dispensadores de molhos frios
- IT Dispenser per salse fredde
- BG Диспенсьри за студени сосове
- EL Δοχεία για κρύες σάλτσες
- ZH 调料瓶



PE



YATO	COLOUR	V (l)	H (mm)	Ø (mm)
YG-00550	●	0.35	200	60
YG-00551	●	0.35	200	60
YG-00552	○	0.35	200	60
YG-00553	●	0.7	260	65
YG-00554	●	0.7	260	65
YG-00555	○	0.7	260	65

### Soup kettle

- DE Suppenkessel
- RU Мармит электрический для супа
- UK Казанок для супів
- LT Sriubos marmitas
- LV Katls zupām
- CS Kotlík na polévku
- SK Kotlíky na polievky
- HU Levesmelegítő
- RO Supieră electrică
- ES Olla de sopa
- FR Marmite à soupe
- PT Chaleira de sopa
- IT Bollitore per zuppa
- BG Супник
- EL Καζάνι για σούπες
- ZH 汤壶

400W 9L SS 304 BARELL 35-85 °C x4 PLASTIC FEET

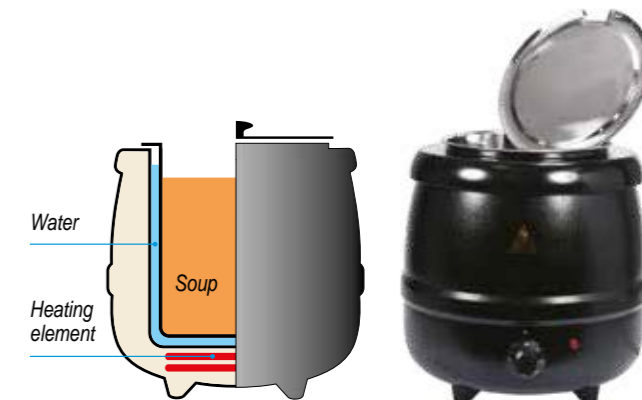

YATO	V (l)	(mm)	(W)
YG-04250	9	340 x 340 x 370	400

**Buffet heaters**

DE Speisenwärmer  
RU Мармиты буфетные  
UK Буфетні підігрівачі  
LT Maisto šildytuvai  
LV Bufešu sildītāji  
CS Bufetové ohřivače  
SK Bufetové ohrievače  
HU Büfé melegítők  
RO Chafing dish  
ES Calentadores de comida para buffet  
FR Buffets chauffants

PT Aquecedores para buffets  
IT Scaldavivande per catering  
BG Настолни бен марита  
EL Θερμάστρα μπουφέ  
ZH 自助餐炉

FOR:  
**GN 1/1**  
max 65 mm

**90°**  
COVER  
OPEN ANGLE

**x2**  
HANDLES

**SEE ALSO**  
tongs and spoons



p. 25

**SS 201**  
STAINLESS STEEL

HEAT SOURCE:  
FUEL / HEATER



**x2**  
HANDLES



Roll-top heater GN 1/1

YATO	V (l)	(mm)
YG-04120	9	600 x 350 x 430

FOR:  
**GN 1/1**  
max 65 mm

**180°**  
COVER  
OPEN ANGLE



Roll-top heater GN 1/1

YATO	V (l)	(mm)
YG-04140	9	640 x 420 x 440



Heater with kettles

YATO	V (l)	(mm)
YG-04125	2 x 4.5	600 x 350 x 370

FOR:  
**GN**  
ø 350 mm

**180°**  
COVER  
OPEN ANGLE



Round roll-top heater

YATO	V (l)	(mm)
YG-04145	6	470 x 450

**Water boilers**

DE Wasserkocher  
RU Электрокипятильник воды  
UK Термопоти  
LT Vandens viryklės  
LV Tējannas  
CS Vaříče na vodu  
SK Ohrievače na varenie vody  
HU Vízmelegítők  
RO Fierbător  
ES Hervidores de agua  
FR Bouilloires d'eau  
PT Dispensadores de água  
IT Distributori a termos per acqua  
BG Машини за чай  
EL Βραστήρας νερού  
ZH 开水桶

YATO	V (l)	(W)
YG-04301	8.8	1000
YG-04310	10.0	1650
YG-04315	15.0	1800
YG-04318	16.0	2600
YG-04324	22.0	3000

**Collection tray**

DE Abtropftablett  
RU Поддон для сбора капель  
UK Піддон для стоків  
LT Nulašėjimo dėklas  
LV Notekraplāte  
CS Odtékací táč  
SK Odkvapkováacia miska

HU Csepegtető tábla  
RO Tavă colectoare  
ES Bandeja con rejilla para el goteo  
FR Plateau d'égouttement  
PT Bandeja de gotejamento

IT Vaschetta raccogli-gocce  
BG Тавичка за оттичане на вода  
EL Δοχείο συλλογής  
ZH 滴水盘



YATO	FOR:
YG-04325	YG-04301, YG-04310, YG-04315, YG-04318, YG-04324

**Water boilers**

DE Wasserkocher  
RU Электрокипятильник воды  
UK Термопоти  
LT Vandens viryklės  
LV Tējannas  
CS Vaříče na vodu  
SK Ohrievače na varenie vody  
HU Vízmelegítők  
RO Fierbător  
ES Hervidores de agua  
FR Bouilloires d'eau  
PT Dispensadores de água  
IT Distributori a termos per acqua  
BG Машини за чай  
EL Βραστήρας νερού  
ZH 开水桶

YATO	V (l)	(W)
YG-04311	9.0	2000
YG-04316	12.0	2500
YG-04319	18.0	2500
YG-04321	25.0	3000

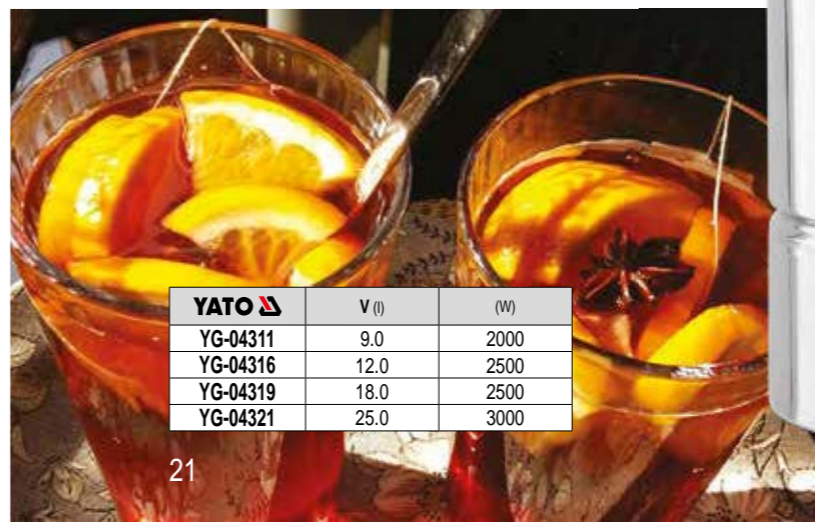

**SS**  
STAINLESS STEEL

30-110°C



**SS**  
STAINLESS STEEL

30-110°C



### Vacuum flasks

- |                       |  |
|-----------------------|--|
| DE Tischthermoskannen | ES Jarras y termos de mesa                 |
| RU Настольные термосы | FR Thermos isothermes pour la restauration |
| UK Столові термоси    | PT Garrafa térmica de mesa                 |
| LT Stalo termosai     | IT Thermos in acciaio                      |
| LV Galda termosī      | BG Настолни термоси                        |
| CS Stolní termoska    | EL Επιτραπέζιες θερμομονωτικές φιάλες      |
| SK Stolové termosky   | ZH 真空保温壶                                   |
| HU Asztali termoszok  |  |
| RO Termosuri          |  |



**SS 201**  
STAINLESS STEEL

**DOUBLE WALL**

**THERMAL ISOLATION**



YATO	V (l)
YG-07013	1.5
YG-07014	2.0



YATO	V (l)
YG-07026	1.5
YG-07027	2.0



YATO	V (l)
YG-07016	2.2

YATO	V (l)
YG-07019	5.0
YG-07020	3.0

### Drink dispenser

- |                           |                             |
|---------------------------|-----------------------------|
| DE Getränkespender        | RO Dozator pentru băuturi   |
| RU Диспенсер для напитков | ES Dispensador de bebidas   |
| UK Дозатор для напоїв     | FR Distributeur de boissons |
| LT Gėrimų dozatorius      | PT Dispensador de bebidas   |
| LV Dzērienu dozatori      | IT Dispenser di bevande     |
| CS Dávkovač na nápoje     | BG Дозатор за напитки       |
| SK Dávkovač na nápoje     | EL Διανομέας ποτών          |
| HU Italadagoló            | ZH 果汁鼎                      |



YATO	V (l)
YG-07001	8

**8L**

**350x260  
x600  
mm**

**SS 201**  
STAINLESS STEEL

**PC**



**REMOVABLE  
BARELL**

### Sauce dispensers

- |                          |                            |
|--------------------------|----------------------------|
| DE Soßenspender          | ES Dispensadores de salsas |
| RU Диспенсеры для соусов | FR Distributeurs de sauce  |
| UK Дозатори для соусів   | PT Dispensadores de molhos |
| LT Sulčių dozatoriai     | IT Dispenser di salse      |
| LV Mērču dozatori        | BG Дозатори за сосове      |
| CS Dávkovač na omáčky    | EL Διανομέας για σάλτσες   |
| SK Dávkovač na omáčky    | ZH 酱汁分配器                   |
| HU Szószadagoló          |                            |
| RO Dozator pentru sosuri |                            |



**YG-00557**  
**1x3L**

YATO	V (l)	(mm)
YG-00557	3	185 x 185 x 355
YG-00558	6	365 x 185 x 355
YG-00559	9	545 x 185 x 355

**YG-00559**  
**3x3L**

**YG-00558**  
**2x3L**



**SS 304/201**  
STAINLESS STEEL

**REMOVABLE  
CONTAINER  
INSIDE**



**Jugs for drinks**

- |                         |                        |                      |
|-------------------------|------------------------|----------------------|
| DE Krüge für Getränke   | CS Džbánky na nápoje   | PT Jarros de bebidas |
| RU Кувшины для напитков | SK Džbánky na nápoje   | IT Brocche per acqua |
| UK Глечики для напоїв   | HU Italkannák          | BG Кани за напитки   |
| LT Gėrimų ąsočiai       | RO Carafe              | EL Κανάτες ποτών     |
| LV Dzērienu krūzes      | ES Jarras para bebidas | ZH 冷水壺               |
|                         | FR Pichets à boissons  |                      |



YATO	V (l)	H (mm)	Ø (mm)
YG-07005	0.8	165	105
YG-07006	1.3	240	85
YG-07007	1.8	180	130



PC

**Tiered platter for fruit and biscuits**

- |  |
|--|
| DE Etage für Obst und Kekse                    |
| RU Этажерка для фруктов и печенья              |
| UK Сервірувальна підставка для фрукти і печиво |
| LT Vaisių ir pyragų serviravimo stovas         |
| LV Kūku un augļu paliknis                      |
| CS Mísa na ovoce a sušenky                     |
| SK Mísa na ovocie a zákusky                    |
| HU Gyümölcs és sütemény kínáló                 |
| RO Suport pentru fructe și prăjituri           |
| ES Bandeja para frutas y pasteles              |
| FR Plateau pour fruits et gâteaux              |
| PT Tigela para frutas e bolos                  |
| IT Vassoio per frutta e torte                  |
| BG Постава за сладки и плодове                 |
| EL Μπολ φρούτων και μπισκότων                  |
| ZH 不锈钢果盘                                       |



YATO	Ø (mm)	H (mm)
YG-08202	165 / 219 / 267	300

**Ice cube tongs**

- |                                   |
|-----------------------------------|
| DE Eiszange                       |
| RU Шипцы для льда                 |
| UK Щипці для льоду                |
| LT Žnyplės ledui                  |
| LV Ledus stangas                  |
| CS Kleště na led                  |
| SK Kliešte na ľad                 |
| HU Jégcsipesz                     |
| RO Clește pentru cuburi de gheață |
| ES Alicates para hielo            |
| FR Pince à glace                  |
| PT Pinças de gelo                 |
| IT Pinze per ghiaccio             |
| BG Щипки за лед                   |
| EL Λαβίδα πάγου                   |
| ZH 冰块夹                            |



YATO	L (mm)
YG-02735	100
YG-02736	150

**Sugar cube tongs**

- |                                  |
|----------------------------------|
| DE Zuckerrange                   |
| RU Шипцы для сахара              |
| UK Щипці для цукру               |
| LT Žnyplės cukrui                |
| LV Cukura stangas                |
| CS Kleště na cukr                |
| SK Kliešte na cukor              |
| HU Cukorcsipesz                  |
| RO Clește pentru cuburi de zahăr |
| ES Alicates para azúcar          |
| FR Pince à sucre                 |
| PT Pinças de açúcar              |
| IT Pinze per zucchero            |
| BG Щипки за захар                |
| EL Λαβίδα ζάχαρης                |
| ZH 方糖夹                           |



YATO	L (mm)
YG-02733	155

**Tongs**

- |             |           |
|-------------|-----------|
| DE Zange    | FR Pince  |
| RU Щипцы    | PT Pinças |
| UK Щипці    | IT Pinze  |
| LT Žnyplės  | BG Щипки  |
| LV Stangas  | EL Λαβίδα |
| CS Kleště   | ZH 不锈钢夹   |
| SK Kliešte  |           |
| HU Csipesz  |           |
| RO Clești   |           |
| ES Alicates |           |



SS18/8  
STAINLESS STEEL

**Bread serving tongs**

YATO	L (mm)
YG-02731	220

**Roast meat serving tongs**

YATO	L (mm)
YG-02730	195

**Spaghetti serving tongs**

YATO	L (mm)
YG-02732	215

**Buffet accessories**

- |                               |
|-------------------------------|
| DE Buffetzubehör              |
| RU Буфетные приборы           |
| UK Буфетні аксесуари          |
| LT Stalo serviravimo įrankiai |
| LV Bufešu piederumi           |
| CS Bufetové pomůcky           |
| SK Bufetové výrobky           |
| HU Bűfé termékek              |
| RO Accesorii buffet           |
| ES Artículos para buffet      |
| FR Pince buffet               |
| PT Artigos de buffet          |
| IT Articoli da buffet         |
| BG Артикули за бюфет          |
| EL Αντικείμενα για μπουφέ     |
| ZH 自助餐配件                      |



SS18/8  
STAINLESS STEEL

**Spaghetti spoon**

YATO	L (mm)
YG-02780	340

**Ladle**

- 120 ml

YATO	L (mm)
YG-02776	315

**Salad fork**

YATO	L (mm)
YG-02778	300

**Serving spoon**

YATO	L (mm)
YG-02775	300

**Slotted serving spoon**

YATO	L (mm)
YG-02774	300

**Slotted spoon**

- Ø110 mm

YATO	L (mm)
YG-02773	370

**Spatula**

- 80 x 105 mm

YATO	L (mm)
YG-02772	360

**Meat knife**

YATO	L (mm)
YG-02771	315

**Meat fork**

YATO	L (mm)
YG-02770	280

**Cake spatula**

YATO	L (mm)
YG-02779	275

### Banquet trays

- |                                    |                          |                            |
|------------------------------------|--------------------------|----------------------------|
| DE Banketttablets                  | CS Banketní tácy         | RO Tăvi                    |
| RU Подносы банкетные прямоугольные | SK Banketové podnosy     | ES Bandejas para banquetes |
| UK Банкетні підноси                | HU Bankett tálcák        | FR Plateaux de banquet     |
| LT Padėklai                        | IT Vassoio per banchetti | PT Bandejas de banquetes   |
| LV Banketu paplātes                | BG Банкетни подноси      | EL Δίσκοι για εορτές       |
|                                    |                          | ZH 不锈钢盘                    |



YG-02057

YG-02055

YATO	(mm)
YG-02055	220 x 150
YG-02057	380 x 240

### Serving tray

- |                          |                                      |   |
|--------------------------|--------------------------------------|---|
| DE Präsentiertablett     | RU Декоративный прямоугольный поднос | UK Теплоізоляційний контейнер для льоду |
| LT Ekspozicinis padėklas | LV Ekspozīcijas paplāte              | CS Výstavní tácy                        |
| SK Prezentačné podnosy   | HU Felszolgáló tálcá                 | RO Tăvi pentru servit                   |
| ES Bandeja expositoria   | FR Plateau de présentation           | PT Bandeja de exposição                 |
| IT Vassoio espositivo    | BG Поднос                            | EL Δίσκος εκθέσεως                      |
| ZH 托盘                    |                                      |   |



SS18/8  
STAINLESS STEEL



YATO	(mm)
YG-02056	305 x 215

### Non-slip waiter trays

- |  |  |   |
|--|--|---|
| DE Rutschfeste Kellnertablets            | LV Paplāte viesmilim, neslidoša            | FR Plateaux antidérapants pour serveurs       |
| RU Антискользящие подносы для официантов | CS Protiskluzové číšnícké tácy             | PT Bandejas antiderrapantes para garçons      |
| UK Нековзні підноси для офіціантів       | SK Čašnicke podnosy protišmykové           | IT Vassoio antiscivolo da cameriere           |
| LT Neslidūs padėklai padavėjams          | HU Csúszásmentes pincértálcák              | BG Сервитьорски табли с неплъзгаща горна част |
|  | RO Tăvi de servit anti-alunecare           | EL Αντιολισθητικοί δίσκοι σερβιτόρων          |
|  | ES Bandejas antideslizantes para camareros | ZH 防滑托盘                                       |

ANTI-SLIP SURFACE

FIBREGLOSS



### Rectangular trays

YATO	(mm)
YG-02075	460 x 355
YG-02076	515 x 380
YG-02077	560 x 405
YG-02078	650 x 450



### Round trays

YATO	Ø (mm)
YG-02079	355
YG-02080	405

### Oval trays

YATO	(mm)
YG-02084	590 x 490
YG-02087	600 x 735

### Buffet tray made of polypropylene

- |                  |                |            |
|------------------|----------------|------------|
| DE Buffettablett | SK Podnosy     | IT Vassoio |
| RU Поднос        | HU Tálcá       | BG Поднос  |
| UK Підноси       | RO Tăvi        | EL Δίσκος  |
| LT Padėklas      | ES Expositoria | ZH 托盘      |
| LV Paplāte       | FR Plateau     |            |
| CS Tácy          | PT Bandeja     |            |

YATO	(mm)
YG-02105	430 x 300

PP

### Thermally insulated ice bucket

- |   |                                     |   |
|---|-------------------------------------|---|
| DE Thermoisolierter Eisbehälter                     | RU Термоёмкость для льда            | UK Теплоізоляційний контейнер для льоду |
| LT Termoizoliacinis indas ledui                     | LV Ledus termoss                    | CS Termoizolační nádoba na led          |
| SK Termoizolačná nádoba na ľad                      | HU Hőszigetelt jégtartó             | RO Container termoizolant pentru gheață |
| ES Contenedor de aislamiento térmico para hielo     | FR Conteneurs isothermes pour glace | PT Recipiente de gelo com isolamento    |
| IT Contenitore a isolamento termico per il ghiaccio | BG Съд за лед с двойни стени        | EL Θερμικός μονωμένο δοχείο για πάγο    |
| ZH 保温冰桶   |                                     |   |

ABS/PP



YATO	V (l)	H (mm)	Ø (mm)
YG-07143	1.1	200	140

### Ice bucket

- |                       |                                |                        |
|-----------------------|--------------------------------|------------------------|
| DE Eisbehälter        | RU Емкость для льда            | UK Контейнер для льоду |
| LT Indas ledui        | LV Ledus trauks                | CS Nádoba na led       |
| SK Nádoba na ľad      | HU Jégtartó                    |                        |
| RO Vas pentru gheață  | ES Contenedor para hielo       | FR Conteneur à glace   |
| PT Recipiente de gelo | IT Contenitore per il ghiaccio | BG Съд за лед          |
| EL Δοχείο πάγου       | ZH 亚克力冰桶                       |                        |

ACRYLIC



SEE ALSO  
ice cube tongs

p. 24

YATO	V (l)	H (mm)	Ø (mm)
YG-07146	1.1	125	125

### Wine bottle cooler

- |   |                              |  |
|---|------------------------------|--|
| DE Thermoisolierter Weinbehälter                | RU Термоконтейнер для вина   | UK Теплоізоляційний контейнер для вина         |
| LT Termoizoliacinis indas vynui                 | LV Vīna termoss              | CS Termoizolační nádoba na víno                |
| SK Termoizolačná nádoba na víno                 | HU Hőszigetelt bortartó      | RO Container termoizolant pentru sticle de vin |
| ES Cubo enfriador de vino con aislamiento       | FR Seau à vin isotherme      | PT Recipiente de vinho com isolamento          |
| IT Contenitore a isolamento termico per il vino | BG Термоизолиран съд за вино | EL Θερμικός μονωμένο δοχείο για κρασί          |
| ZH 酒瓶冷藏器  |                              |  |

ACRYLIC



YATO	V (l)	H (mm)	Ø (mm)
YG-07147	1.4	235	125

### Champagne bucket

- |                            |                          |                           |
|----------------------------|--------------------------|---------------------------|
| DE Sektkühler              | RU Ведро для шампанского | UK Відро для шампанського |
| LT Dubuo šampano buteliams | LV Šampanieša spainis    | CS Nádoba na šampaňské    |
| SK Vedierko na šampanské   | HU Pezsgősvödör          | RO Frapieră               |
| ES Cubo de champán         | FR Vasque à champagne    | PT Balde para champanhe   |
| IT Vasca per champagne     | BG Кофичка за шампанско  | EL Κουβάς σαμπάνιας       |
| ZH 不锈钢香槟桶                  |                          |                           |

SS201  
STAINLESS STEEL

3.8L

Ø 180 mm



YATO	V (l)	Ø (mm)	H (mm)
YG-07141	3.8	80	196

### Cocktail shakers

- |                          |                           |
|--------------------------|---------------------------|
| DE Coctail-Shaker        | FR Shakers                |
| RU Шейкеры для коктейлей | PT Coqueteleiras          |
| UK Шейкери для коктейлів | IT Agitatore per cocktail |
| LT Kokteilių plaktuvai   | BG Шейкър за коктейли     |
| LV Kokteīļu šeikeri      | EL Σέικερ κοκτέιλ         |
| CS Šejkr na koktejl      | ZH 不锈钢调酒壶                 |
| SK Shakery na koktaily   |                           |
| HU Koktél shakerek       |                           |
| RO Shaker                |                           |
| ES Cocteleras            |                           |

SS201  
STAINLESS STEEL



YATO	V (l)	Ø (mm)	H (mm)
YG-07121	0.5	70	178
YG-07123	0.7	80	248

### Reception bell

DE Rezeptionsklingel  
RU Звонок для рецепции  
UK Дзвінок рецепції  
LT Registratūros skambutis  
LV Reserpcijas zvans  
CS Reserční zvoněk  
SK Reserčný zvonček  
HU Reserpció csengő  
RO Sonerie pentru recepție  
ES Timbre de recepción  
FR Cloche de réception  
PT Sino de recepção  
IT Campanello da reception

85 mm  
CAST IRON



YATO	Ø (mm)
YG-02720	85

### Citrus juicer

DE Zitruspresse  
RU Ручная соковыжималка для цитрусовых  
UK Прес для цитрусових  
LT Rankinė sulčiaspaudė citrusams  
LV Citrusaugļu sulu spiede  
CS Lis na citrusy  
SK Lis na citrón  
HU Citrusfacsaró  
RO Storcător de citrice  
ES Exprimidor de cítricos  
FR Extracteur de jus d'agrumes  
PT Espremedor de frutas cítricas  
IT Spremiagrumi  
BG Цитрус преса  
EL Αποχυμωτής εσπεριδοειδών  
ZH 不锈钢榨汁器

SS202  
STAINLESS STEEL



YATO	Ø (mm)	Ø CONE (mm)
YG-07108	120	65

### Bartender container

DE Barkeeper-Behälter  
RU Ящик для бармена  
UK Барменський контейнер  
LT Barmeno indas  
LV Bāra trauks  
CS Barmanská nádoba  
SK Barmanská nádoba  
HU Bár doboz  
RO Recipient depozitare pentru bar  
ES Recipiente de bar  
FR Bac à compartiments  
PT Recipiente de barman  
IT Contenitore per bar  
BG Бар органайзер за плодове  
EL Δοχείο μπάρμαν  
ZH 果盒调味盒

X5 COMPARTMENTS  
ABS  
PP PC



YATO	H (mm)
YG-07080	500 x 160 x 100

### Bartending spoon

DE Barlöffel  
RU Барная ложка  
UK Барменська ложка  
LT Barmeno šaukštėlis  
LV Bāra karote  
CS Barmanská lžička  
SK Barmanská lyžička  
HU Koktélikanál  
RO Liguriță pentru barman  
ES Cuchara con mango largo

330 mm  
SS18/0  
STAINLESS STEEL



YATO	L (mm)
YG-07136	330

### Bartender's organiser

DE Behälter für Barkeeper-Zubehör  
RU Барный органайзер  
UK Контейнер для барменського приладдя  
LT Padėklas barmeno įrankiams  
LV Trauks bāra piederumiem  
CS Nádoba na barmanské příslušenství  
SK Nádoba na barmanské príbory  
HU Bártartozék tároló  
RO Organizator bar  
ES Contenedor para accesorios de barman

FR Bac caddy  
PT Recipiente para acessórios de barman  
IT Contenitore per accessori per bar  
BG Бар органайзер  
EL Δοχείο για αξεσουάρ μπάρμαν  
ZH 纸巾盒

X6 SEGMENTS

ABS

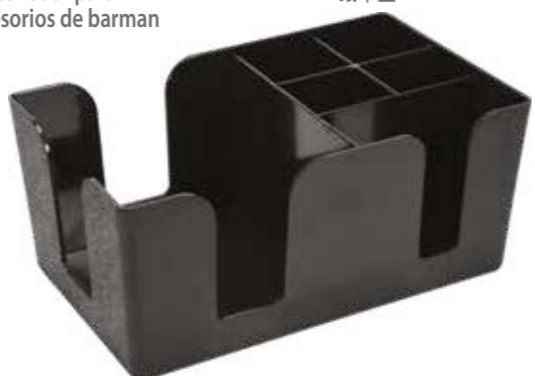

YATO	H (mm)
YG-07134	100

### Glass rimmer

DE Krustenmacher  
RU Риммер  
UK Крастовка  
LT Stovai taurių dekoravimui  
LV Bāra organizātors glāžu dekorēšanai  
CS Zdobítčko skleniček  
SK Nástroj na dekorovanie pohárov  
HU Koktél szervíz  
RO Rimmer pentru pahare  
ES Escarchador  
FR Sel de cocktail coffret barman  
PT Acessório de decoração de taças

ABS



IT Guarnitore bordi bicchieri  
BG Сет за украсяване на чаши за коктейли  
EL Glass rimmer για κοκτέιλ  
ZH 调味盒

YATO	H (mm)	Ø (mm)
YG-07102	70	150

### Bartender mats

DE Barkeeper-Matten  
RU Барные коврики  
UK Коврики для барменів  
LT Baro kilimėliai  
LV Bāra paklāji  
CS Barmanské podložky  
SK Barmanské rohože  
HU Bár alátét  
RO Suporturi pentru bar  
ES Esteras de goma para la barra  
FR Tapis de bar en caoutchouc

PT Tapetes de barman  
IT Tappetino da bar  
BG Бар подложки  
EL Μπάρ ψάθες  
ZH 长吧垫

TPR



YATO	H (mm)
YG-07100	590 x 80 x 15
YG-07101	460 x 310 x 10

### Drink dispensers

DE Barkeeper-Spender  
RU Диспенсеры для бара  
UK Барменські диспенсери  
LT Baro buteliukai skysčiams dozuoti  
LV Bāra dispenserī  
CS Barmanské dávkovače  
SK Barmanské dispenzéry  
HU Adagoló tubusok  
RO Barman dispenser  
ES Dispensadores de barman  
FR Flacon verseur  
PT Distribuidores para barman  
IT Dispenser per bar  
BG Бар диспенсери  
EL Διανομείς μπάρμαν  
ZH 饮料壶

1 L

PP/PS



YATO	COLOUR	V (l)	H (mm)	Ø (mm)
YG-07115	Red	1	330	90
YG-07116	Blue	1	330	90
YG-07117	Green	1	330	90
YG-07118	Brown	1	330	90
YG-07119	Yellow	1	330	90

### Bottle opener

DE Flaschenöffner  
RU Открывалка для бутылок  
UK Відкривачка для пляшок  
LT Butelių atidarytuvas  
LV Pudedļu attaisāmais  
CS Otevírač na láhve  
SK Otvárač na fľaše  
HU Sörbontó  
RO Desfacător de sticle

SS  
STAINLESS STEEL



YATO	H (mm)
YG-07139	175 x 40 x 2

### Plugs with dispensers

DE Ausgießer  
RU Пробки с дозаторами  
UK Пробки з дозаторами  
LT Kamščiai su dozatoriais  
LV Korķi ar dozatoriem  
CS Korky s dávkovači  
SK Zátky s dávkovačmi  
HU Adagoló kupak

RO Picurător  
ES Tapones con dosificador para botellas  
FR Becs verseurs pour les bouteilles  
PT Rolhas com dispensadores  
IT Tappi con dosatori  
BG Тапи с дозатори  
EL Φελλό με διανομείς  
ZH 不锈钢瓶头

PP



YATO	COLOUR
YG-07126	Blue
YG-07127	Pink
YG-07128	Red
YG-07129	Black
YG-07130	Green
YG-07131	White



### Plug with dispenser

DE Ausgießer  
RU Пробка с дозатором  
UK Пробка з дозатором  
LT Kamštis su dozatoriumi  
LV Korķis ar dozatoru  
CS Korek s dávkovačem  
SK Zátka s dávkovačom  
HU Adagoló dugó  
RO Picurător din oțel inoxidabil  
ES Tapón con dosificador para botellas  
FR Bec verseur pour les bouteilles

SS  
STAINLESS STEEL

TPR



YATO	COLOUR
YG-07125	Black





### Bone saw

DE Knochensäge  
RU Костяная пила  
UK Пилка для кісток  
LT Kaulų pjūklas  
LV Kaulu zāģis  
CS Pila na kosti  
SK Pila na kosti  
HU Csontfűrész  
RO Fierastrau de oase  
si carne congelată  
ES Sierra para huesos  
FR Scie à os  
PT Serra de osso  
IT Segatrice  
BG Трион за кости  
EL Πριόνι κρέατος οστών  
ZH 锯骨机



<b>750W</b>	<b>1650 mm</b> BLADE	<b>MAX 245 mm</b> CUTTING HIGH
<b>1400 min<sup>-1</sup></b> CUTTING SPEED	<b>3-180 mm</b> SLICES	<b>Al-Mg</b> ANODIZED
	<b>SS</b> STAINLESS STEEL	



YATO	(W)	(mm)	TABLE (mm)
YG-03392	750	870 x 450 x 465	440 x 465

### Meat mincer with Unger system

DE Fleischwolf  
RU Машина для измельчения мяса  
UK Машинка для подрібнення м'яса  
LT Mėsmalė  
LV Gaļas maļamā mašina  
CS Sroj pro mletí masa  
SK Mlynček na mäso  
HU Húsdaráló  
RO Maşina de tocat carne  
ES Picadora de carne  
FR Hachoir à viande  
PT Moedor de carne  
IT Macchina per la macinazione della carne  
BG Месомелачка  
EL Μηχανή για άλεση κρέατος  
ZH 碎肉机

<b>Al-Mg</b> ANODIZED	<b>SS</b> STAINLESS STEEL	<b>PE</b>	<b>EMERGENCY STOP SWITCH</b>		<b>x2</b> <b>10 mm</b>	<b>6 mm</b>
--------------------------	------------------------------	-----------	------------------------------	--	---------------------------	-------------

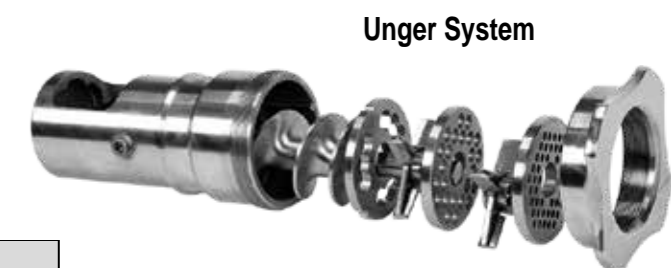

YATO	(kg/h)	(W)	(mm)
YG-03232	220	1100	520 x 390 x 225

### Sausage stuffers

- DE Wurstfüller
- RU Колбасные шприцы
- UK Шприци для ковбас
- LT Dešrų kimštuvai
- LV Desu pildīšanas ierīces
- CS Nadívače klobás
- SK Plniace stroje na výrobu klobásy
- HU Kolbásztöltő
- RO Aparat de umplut cârnați
- ES Embutidora de salchichas
- FR Remplisseuse de saucisses
- PT Enchedores de linguiças
- IT Riempitrici per salsicce
- BG Пълначка за колбаси
- EL Γεμιστικά για λουκάνικα
- ZH 灌肠机



- SS**  
STAINLESS STEEL
- x4**  
RUBBER FEET
- 16 mm  
22 mm  
32 mm  
38 mm
- x2**  
SPEED
- EASY TO CLEAN**



YATO	V (l)	(kg/h)	(mm)	CYLINDER (mm)
YG-03350	3	11	300 x 340 x 570	140 x 200
YG-03360	5	12	300 x 340 x 690	140 x 320
YG-03370	7	13	300 x 340 x 830	140 x 460
YG-03380	15	17	370 x 330 x 710	219 x 400

### Hamburger presses

- DE Hamburgerpressen
  - RU Пресс для гамбургеров
  - UK Преси для гамбургерів
  - LT Mėsainių presai
  - LV Hamburgeru preses
  - CS Lisy na hamburgery
  - SK Lisy na hamburgery
  - HU Hamburger prések
  - RO Presă pentru hamburgeri
- ES Prensas para hamburguesas
  - FR Presse-hamburger
  - PT Prensas de hamburguesas
  - IT Presse per hamburger
  - BG Преса за хамбургери
  - EL Πρέσα χάμπουρκερ
  - ZH 汉堡机



YATO	Ø (mm)
YG-03400	100
YG-03405	130



- SS**  
STAINLESS STEEL
- x4**  
RUBBER FEET

### Meat and cheese slicers

- DE Schneidemaschinen für Wurst und Käse
- RU Ломтерезки для колбас и сыра
- UK Скиборізки для м'яса і сирів
- LT Dešrų, kumprių ir sūrių pjaustyklės
- LV Griezējierīces žāvējumiem un sieriem
- CS Kráječ na uzeniny a sýry
- SK Rezačie stroje na údeniny a syry
- HU Kolbász- és sajtszeletelő
- RO Feliatoare pentru carne și mezeluri
- ES Cortafiambres y loncheadoras para queso
- FR Trancheuses à viande et à fromage
- PT Cortadores de frios e queijos
- IT Affettatrici per salumi e formaggi
- BG Машини за рязане на колбаси и сирена
- EL Κόφτες για λουκάνικα και τυρί
- ZH 肉和奶酪切片机



- AI**
- SEMI-AUTOMATIC SHARPENING**



#### YG-03110

- maximum diameter of sliced products: 150 mm
- slice thickness: 0.2-12 mm



#### YG-03118

- maximum diameter of sliced products: 180 mm
- slice thickness: 0.2-12 mm



#### YG-03120

- maximum diameter of sliced products: 180 mm
- slice thickness: 0.2-12 mm



#### YG-03130

- maximum diameter of sliced products: 200 mm
- slice thickness: 0.2-15 mm



YATO	(W)	Ø (mm)	TABLE (mm)	(mm)
YG-03110	120	220	200 x 230	470 x 340 x 370
YG-03118	150	250	200 x 230	470 x 360 x 410
YG-03120	150	250	200 x 230	470 x 380 x 410
YG-03130	250	300	255 x 275	530 x 450 x 450

### Tomato slicers

DE Schneidemaschinen für Tomaten  
RU Слайсеры для томатов  
UK Слайсери для томатів  
LT Pomidorų pjaustyklės  
LV Griezējierīces tomātiem  
CS Kráječ na rajčata  
SK Krájač paradajok  
HU Paradicsom szeletelő  
RO Feliatoare pentru roșii

ES Cortadoras de tomate  
FR Coupe-tomates  
PT Cortadores de tomate  
IT Affettatrici per pomodori  
BG Резачки за домати  
EL Κόφτες για ντομάτες  
ZH 番茄切片机



YG-03410

**x13**  
BLADES  
**4.0 mm**  
CUTTING THICKNESS



YG-03415

**x10**  
BLADES  
**5.5 mm**  
CUTTING THICKNESS

<b>YATO</b>
YG-03410
YG-03415

### Tomato slicers

DE Schneidemaschinen für Tomaten  
RU Слайсеры для томатов  
UK Слайсери для томатів  
LT Pomidorų pjaustyklės  
LV Griezējierīces tomātiem  
CS Kráječ na rajčata  
SK Krájač paradajok  
HU Paradicsom szeletelő  
RO Feliatoare pentru roșii  
ES Cortadoras de tomate  
FR Coupe-tomates  
PT Cortadores de tomate  
IT Affettatrici per pomodori  
BG Резачки за домати  
EL Κόφτες για ντομάτες  
ZH 番茄切片机



**SS**  
STAINLESS STEEL

YATO	PARTS (pcs.)	H (mm)	Ø (mm)
YG-03420	6	480	350
YG-03421	12	480	350

### Vegetable shredder

DE Gemüsehobel  
RU Овощерезка  
UK Нарізний пристрій для овочів  
LT Daržovių pjaustyklė  
LV Dārzeņu smalcinātājs  
CS Sekáček na zeleninu  
SK Krájač zeleniny  
HU Zöldségvágó  
RO Tocător pentru legume  
ES Trituradora de verduras  
FR Broyeur legume  
PT Cortador de legumes  
IT Trituratore di verdure  
BG Резачка за зеленчуци  
EL Κόπτης λαχανικών  
ZH 蔬菜切碎机

**Al-Mg**  
ANODIZED  
**550W**  
**300kg/h**  
EFFICIENCY  
**x5**  
CUTTING KNIVES  
EMERGENCY  
STOP  
SWITCH



YATO	(kg/h)	(W)	(mm)
YG-03100	300	550	560 x 580 x 240

### Accessories for vegetable shredder

- DE Zubehör für Gemüseschredder  
 RU Аксессуары для тритачки овощей  
 UK АКСЕСУАРИ ДЛЯ ПОДРІБНЮВАЧА ОВОЧІВ  
 LT Priedai daržovių smulkintuvui  
 LV Aksesuāri dārzeņu smalcinātājam  
 CS Příslušenství pro skartovač zeleniny
- SK Príslušenstvo k drviču zeleniny  
 HU Tartozékok növényi aprítóhoz  
 RO Accesorii pentru tocător de legume  
 ES Accesorios para trituradora de verduras  
 FR Accessoires pour broyeur de légumes  
 PT Acessórios para trituradora de vegetais

- IT Accessori per tritacarne  
 BG Аксесоари за раздробяване на зеленчуци  
 EL Αξεσουάρ για τεμαχιστή λαχανικών  
 ZH 蔬菜切碎机配件

∅  
205  
mm

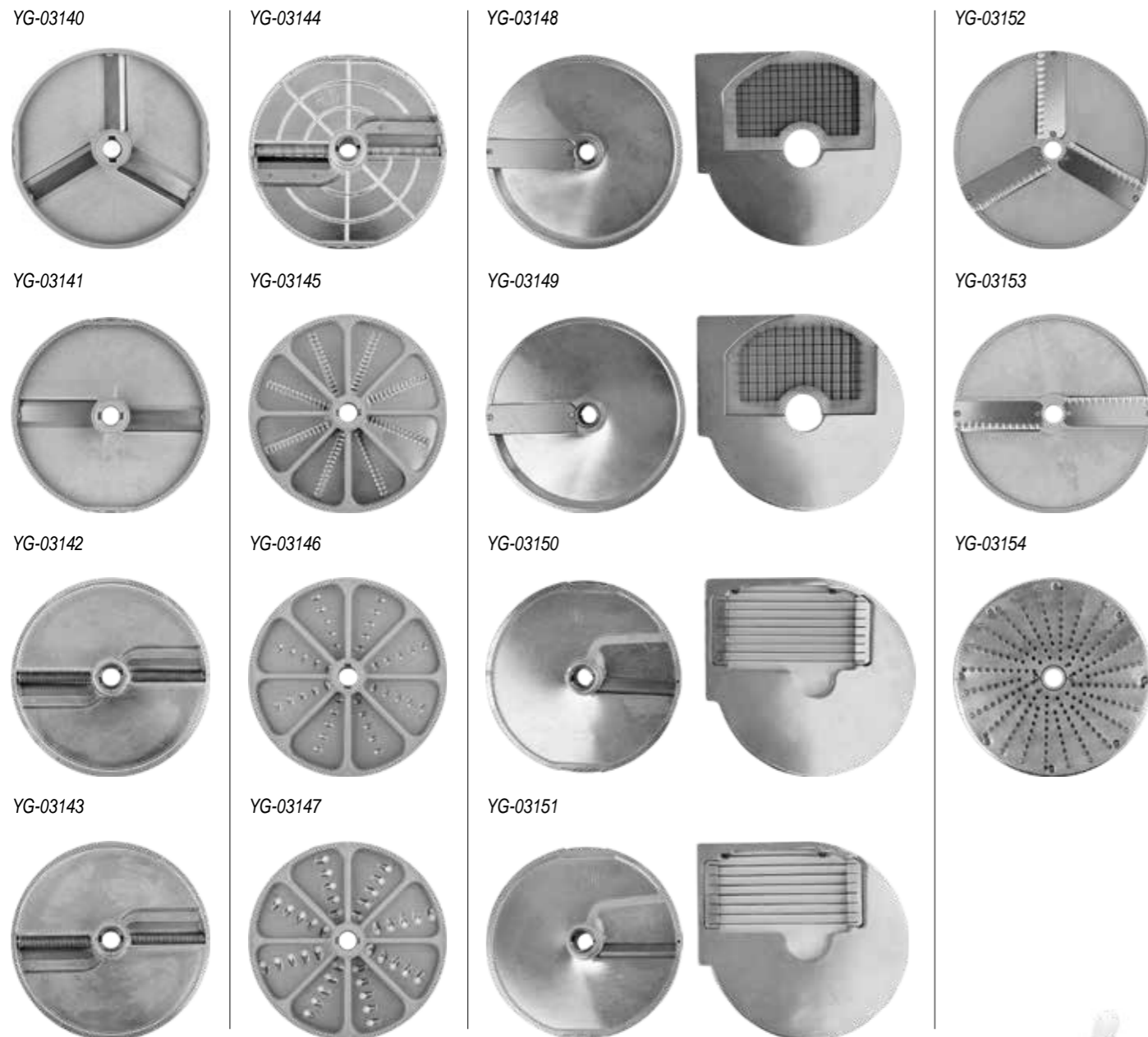

YATO	TYPE	THICKNESS (mm)
YG-03140	SLICES	2
YG-03141	SLICES	4
YG-03142	JULIENNE	2.5 x 2.5
YG-03143	JULIENNE	4 x 4
YG-03144	JULIENNE	10 x 10
YG-03145	SHREDS	3
YG-03146	SHREDS	4
YG-03147	SHREDS	7
YG-03148	CUBES	8 x 8 x 8
YG-03149	CUBES	10 x 10 x 10
YG-03150	CHIPS	8 x 8
YG-03151	CHIPS	10 x 10
YG-03152	WAVY SLICES	2
YG-03153	WAVY SLICES	4
YG-03154	GRATER	-



### Potato peelers

- DE Kartoffelschäler  
 RU Картофелечистка  
 UK Пристрої для чищення картоплі  
 LT Bulvių skutyklės  
 LV Kartupeļu mizotāji  
 CS Oběrač brambor  
 SK Škrabky na zemiaky  
 HU Burgonyahámzó  
 RO Mașină de curățat cartofi  
 ES Peladoras de patatas  
 FR Éplucheuses de pommes de terre  
 PT Descascadores de batata  
 IT Pelapatate  
 BG Машини за белене на картофи  
 EL Αποφλοιωτές πατάτας  
 ZH 马铃薯削皮器



YATO	V (l)	INSERT (kg)	(kg/h)	(W)
YG-03087	15	10	165	750
YG-03090	20	15	225	950



SS  
STAINLESS STEEL

0-5min

SEPARATOR FOR PEELINGS

### Handheld blender

- DE Handmixer  
 RU Ручной блендер  
 UK Ручні блендер  
 LT Rankinis maišytuvas  
 LV Rokas blenderis  
 CS Ruční mixér  
 SK Ručný mixér  
 HU Botmixer  
 RO Blender de mana  
 ES Batidora de mano  
 FR Mélangeur à main  
 PT Mixer de mão  
 IT Frullatore  
 BG Ръчен блендър  
 EL Μίξερ χειρό  
 ZH 手动搅拌器



700W

12600-15000 min<sup>-1</sup> SPEED

x5 SPEED

ANGULAR BLADE

STAINLESS STEEL

SILENT MOTOR

YATO	(W)
YG-03006	700

### Bartender's blender

DE Barkeepermischer  
RU Блендер бармена  
UK Барменський блендер  
LT Barmeno maišytuvas-smulkintuvas  
LV Bāra blenderis  
CS Barmanský mixér  
SK Barmanský mixér  
HU Bármixer  
RO Blender  
ES Batidora de barman  
FR Mélangeur à cocktail  
PT Liquidificador para barman  
IT Frullatore da bar  
BG Бар блендър  
EL Μπλέντερ μπάρμαν  
ZH 调酒师搅拌机

1680W 32000 min<sup>-1</sup> SPEED PULS SPEED SILENT MOTOR SPEED 2500 ml SS 420 BPA FREE X4 RUBBER FEET



YATO	V (l)	(W)	(mm)
YG-07085	2.5	1680	220 x 260 x 540

### Additional cup for the blender

DE Ersatz-Mixbecher  
RU Запасная чаша для блендера  
UK Запасна чаша для блендера  
LT Papildomas maišytuvo-smulkintuvo ąsotis  
LV Blendera rezerves krūze  
CS Náhradní nádoba k mixéru  
SK Náhradná nádoba pre mixér  
HU Tartalék mixertál  
RO Cupă pentru blender  
ES Vaso de repuesto para la batidora

FR Gobelet de rechange pour le mélangeur  
PT Copo de liquidificador sobressalente  
IT Bicchiere di ricambio per frullatore  
BG Резервна кана за блендър  
EL Επιπλέον πλαστική κανάτα για μπλέντερ  
ZH 搅拌机备用杯



YATO	V (l)	(mm)	FOR:
YG-07086	2.5	190 x 250 x 335	YG-07085



### Planetary mixer

DE Planetenmischer  
RU Планетарный миксер  
UK Планетарний міксер  
LT Planetarinis maišytuvas  
LV Planetārais mikseris  
CS Planetární mixér  
SK Planétová miešačka  
HU Bolygókeverő

RO Mixer planetar  
ES Mezclador planetario  
FR Mélangeur planétaire  
PT Batedeira  
IT Miselatore planetario  
BG Планетарен миксер  
EL Πλανητικός αναδευτήρας  
ZH 搅拌机

7L 0-780 min<sup>-1</sup> SPEED 350W SS STAINLESS STEEL



YATO	(W)	V (l)	(min <sup>-1</sup> )	(mm)	Ø KNEADING-TROUGH (mm)	(kg)
YG-03012	350	7	0-780	420 x 400 x 230	220/230	17

### Planetary mixers

- |                             |                            |
|-----------------------------|----------------------------|
| DE Planetenmischer          | ES Mezcladores planetarios |
| RU Планетарные миксеры      | FR Mélangeurs planétaires  |
| UK Планетарні міксери       | PT Batedeiras              |
| LT Planetariniai maišytuvai | IT Miscelatori planetari   |
| LV Planetārie mikseri       | BG Планетарни миксери      |
| CS Planetární mixéry        | EL Πλανητικοί αναδευτήρες  |
| SK Planétové miešacky       | ZH 搅拌机                     |
| HU Bolygókeverők            |                            |
| RO Mixere planetare         |                            |



### Planetary mixer

- |                            |                           |
|----------------------------|---------------------------|
| DE Planetenmischer         | RO Mixer planetar         |
| RU Планетарный миксер      | ES Mezclador planetario   |
| UK Планетарний міксер      | FR Mélangeur planétaire   |
| LT Planetarinis maišytuvas | PT Batedeira              |
| LV Planetārais mikseris    | IT Miscelatore planetario |
| CS Planetární mixér        | BG Планетарен миксер      |
| SK Planétová miešacka      | EL Πλανητικός αναδευτήρας |
| HU Bolygókeverő            | ZH 搅拌机                    |



YATO	(W)	V (l)	(min <sup>-1</sup> )	(mm)	Ø KNEADING-TROUGH (mm)	(kg)
YG-03020	500	15	110/178/355	680 x 475 x 365	270/300	59
YG-03021	1100	20	104/187/365	780 x 500 x 430	320/350	85
YG-03022	1100	30	104/187/365	850 x 540 x 430	340/370	91

YATO	(W)	V (l)	(min <sup>-1</sup> )	(mm)	Ø KNEADING-TROUGH (mm)	(kg)
YG-03023	2200	40	104/206/399	990 x 640 x 520	400/420	152

### Planetary mixers

- |                             |                            |
|-----------------------------|----------------------------|
| DE Planetenmischer          | ES Mezcladores planetarios |
| RU Планетарные миксеры      | FR Mélangeurs planétaires  |
| UK Планетарні міксери       | PT Batedeiras              |
| LT Planetariniai maišytuvai | IT Miscelatori planetari   |
| LV Planetārie mikseri       | BG Планетарни миксери      |
| CS Planetární mixéry        | EL Πλανητικοί αναδευτήρες  |
| SK Planétové miešačky       | ZH 搅拌机                     |
| HU Bolygókeverők            |                            |
| RO Mixere planetare         |                            |

YG-03025

10L

500W



YG-03026

25L

750W



YATO	(W)	V (l)	(min <sup>-1</sup> )	(mm)	Ø KNEADING-TROUGH (mm)	(kg)
YG-03025	500	10	110/178/355	680 x 460 x 370	245/275	63
YG-03026	750	25	110/200/420	840 x 550 x 435	335/370	82

### Kneading-troughs for planetary mixers

- |   |   |
|---|---|
| DE Bottiche für Planetenmischer             | IT Sbattitori per i miscelatori planetari |
| RU Дежи для планетарных миксеров            | BG Купи за планетарни миксери             |
| UK Дежа для планетарних міксерів            | EL Κάδοι για πλανητικούς αναδευτήρες      |
| LT Planetarinių maišytuvų dubenys           | ZH 搅拌机料筒                                  |
| LV Bļodas planetārajiem mikseriem           |   |
| CS Dž pro planetární mixéry                 |   |
| SK Misy pre planétové miešačky              |   |
| HU Tál bolygókeverőkhoz                     |   |
| RO Boluri pentru mixer planetar             |   |
| ES Recipientes para mezcladoras planetarias |   |
| FR Récipients pour mélangeurs planétaires   |   |
| PT Tigelas para batedeiras                  |   |

YATO	FOR:	V (l)
YG-03125	YG-03025	10
YG-03126	YG-03026	25



YG-03125

YG-03126

### Planetary mixers

- |                             |                            |
|-----------------------------|----------------------------|
| DE Planetenmischer          | ES Mezcladores planetarios |
| RU Планетарные миксеры      | FR Mélangeurs planétaires  |
| UK Планетарні міксери       | PT Batedeiras              |
| LT Planetariniai maišytuvai | IT Miscelatori planetari   |
| LV Planetārie mikseri       | BG Планетарни миксери      |
| CS Planetární mixéry        | EL Πλανητικοί αναδευτήρες  |
| SK Planétové miešačky       | ZH 搅拌机                     |
| HU Bolygókeverők            |                            |
| RO Mixere planetare         |                            |



YATO	(W)	V (l)	(min <sup>-1</sup> )	(mm)	Ø KNEADING-TROUGH (mm)	(kg)
YG-03027	1100	35	80/160/388	1020 x 640 x 550	375/395	130
YG-03028	1500	40	80/160/388	1020 x 640 x 550	400/420	132
YG-03029	2000	60	74/155/388	1250 x 750 x 570	460/490	218

### Kneading-troughs for planetary mixers

- |                                   |   |
|-----------------------------------|---|
| DE Bottiche für Planetenmischer   | RO Boluri pentru mixer planetar             |
| RU Дежи для планетарных миксеров  | ES Recipientes para mezcladoras planetarias |
| UK Дежа для планетарних міксерів  | FR Récipients pour mélangeurs planétaires   |
| LT Planetarinių maišytuvų dubenys | PT Tigelas para batedeiras                  |
| LV Bļodas planetārajiem mikseriem | IT Sbattitori per i miscelatori planetari   |
| CS Dž pro planetární mixéry       | BG Купи за планетарни миксери               |
| SK Misy pre planétové miešačky    | EL Κάδοι για πλανητικούς αναδευτήρες        |
| HU Tál bolygókeverőkhoz           | ZH 搅拌机料筒                                    |

YATO	FOR:	V (l)
YG-03127	YG-03027	35
YG-03128	YG-03028	40
YG-03129	YG-03029	60

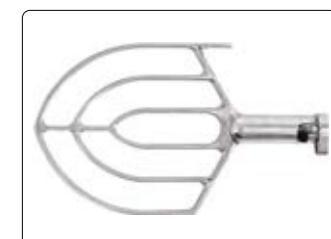

### Spiral mixers

DE Spalrmixer  
RU Спиральные миксеры  
UK Спиральні міксери  
LT Spiraliniai maišytuvai  
LV Spirālie mikseri  
CS Spirálové míxéry  
SK Spirálové miešáčky  
HU Spirál keverők  
RO Malaxore pentru aluat  
ES Amasadoras de espiral  
FR Mélangeur à spirale  
PT Batedeiras espirais  
IT Miscelatori a spirale  
BG Спирални миксери  
EL Σπρικό αναμκτήρες  
ZH 和面机



YATO	(W)	V (l)	(min <sup>-1</sup> )	(mm)	Ø KNEADING-TROUGH (mm)	(kg)
YG-03059	1100	20	158	690 x 760 x 390	360/390	127
YG-03062	1500	30	158	760 x 800 x 440	400/430	138

### Spiral mixers

DE Spalrmixer  
RU Спиральные миксеры  
UK Спиральні міксери  
LT Spiraliniai maišytuvai  
LV Spirālie mikseri  
CS Spirálové míxéry  
SK Spirálové miešáčky  
HU Spirál keverők  
RO Malaxore pentru aluat  
ES Amasadoras de espiral  
FR Mélangeur à spirale  
PT Batedeiras espirais  
IT Miscelatori a spirale  
BG Спирални миксери  
EL Σπρικό αναμκτήρες  
ZH 和面机

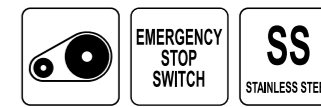

YATO	(W)	V (l)	(min <sup>-1</sup> )	(mm)	Ø KNEADING-TROUGH (mm)	(kg)
YG-03060	1100	20	207	860 x 700 x 390	360/390	89
YG-03063	1500	30	207	890 x 730 x 430	400/430	94



### Spiral mixers

- DE Spiralmixer
- RU Спиральные миксеры
- UK Спіральні міксери
- LT Spiraliniai maišytuvai
- LV Spirālie mikseri
- CS Spirálové mixéry
- SK Spirálové miešačky
- HU Spirál keverők
- RO Malaxore pentru aluat
- ES Amasadoras de espiral
- FR Mélangeur à spirale
- PT Batedeiras espirais
- IT Miscelatori a spirale
- BG Спирални миксери
- EL Σπριρικοί αναμκτήρες
- ZH 和面机

3100W  EMERGENCY STOP SWITCH **SS** STAINLESS STEEL

YG-03068

50L



YG-03065

40L



YG-03065



YG-03068



YATO	(W)	V (l)	(min <sup>-1</sup> )	(mm)	Ø KNEADING-TROUGH (mm)	(kg)
YG-03065	3100	40	125/250	1030 x 730 x 480	450/480	133
YG-03068	3100	50	120/240	1120 x 880 x 530	500/530	189

### Induction cookers

- DE Induktionskochplatten
- RU Индукционные плиты
- UK Індукційні плити
- LT Indukcinės viryklės
- LV Indukcijas plītis
- CS Idukcční plotny
- SK Indukčné variče
- HU Indukciós főzőlapok
- RO Plite cu inducție
- ES Cocinas de inducción
- FR Cuisinières induction
- PT Fogões por indução
- IT Cucine a induzione
- BG Индукционни котлони
- EL Επαγωγικές κουζίνες
- ZH 电磁炉



500-3500 W 1-10 POWER LEVELS Ø 140-260 mm  
CERAMIC GLASS OVERHEATING PROTECTION **SS** STAINLESS STEEL



- stepless power adjustment within the scope of 500-3500 W (in 100 W steps)
- manual control



YATO	(mm)	(W)
YG-04700	325 x 420 x 105	500-3500



MANUAL CONTROL



- power setting from 1 to 10 (within the scope of 500-3500 W, in 100 W steps)
- temperature setting from 1-10 (60-240°C, in 20°C steps)
- timer setting from 0 to 180 minutes (0-30 min. in 1 min. steps, 30-180 min. in 10 min. steps)
- LED display
- electronic control



YATO	(mm)	(W)
YG-04701	325 x 420 x 105	500-3500



DIGITAL CONTROL

0-180min  
TIMER LED  
DISPLAY



### Grill plates

- DE Grillplatten
- RU Гриль-плиты
- UK Плити з грилем
- LT Grilio plokštės
- LV Grila plāksnes
- CS Grilovací desky
- SK Grilovacie dosky
- HU Grill sütőlapok
- RO Grill electric
- ES Placas de parrilla
- FR Plaque à grillade
- PT Chapas grill
- IT Piastra grill
- BG Грилове
- EL Πλάκες σχάρας
- ZH 电扒炉

**SS**  
STAINLESS STEEL

**50-300**  
°C  
WORKING  
TEMPERATURE



• flat surface

YATO	(W)	(mm)	PLATE (mm)	(kg)
YG-04584	2000	365 x 460 x 220	360 x 380 x 6	13.5



• flat surface

YATO	(W)	(mm)	PLATE (mm)	(kg)
YG-04585	3000	555 x 430 x 230	550 x 350 x 9	18.5



• 2/3 flat surface, 1/3 grooved surface

YATO	(W)	(mm)	PLATE (mm)	(kg)
YG-04586	3000	555 x 430 x 230	550 x 350 x 9	18.5



• grooved surface

YATO	(W)	(mm)	PLATE (mm)	(kg)
YG-04587	3000	555 x 430 x 230	550 x 350 x 9	18.5



• flat surface  
• two independently controlled heating zones

YATO	(W)	(mm)	PLATE (mm)	(kg)
YG-04588	2200 + 2200	735 x 510 x 230	730 x 420 x 9	26

### Contact grills

- DE Kontaktgrills
- RU Контактные грили
- UK Контактні грилі
- LT Kontaktiniai griliai
- LV Kontakta grili
- CS Kontaktní grily
- SK Kontaktné grily
- HU Kontakt grill
- RO Contact grill
- ES Parrillas de contacto
- FR Grilles de contact
- PT Grelhas de contato
- IT Griglie di contatto
- BG Контактни грилове
- EL Τοστιέρες-γκριλιέρες
- ZH 电气烧烤炉

**SS**  
STAINLESS STEEL

**50-300**  
°C  
WORKING  
TEMPERATURE



YATO	(W)	(mm)	PLATE (mm)	(kg)
YG-04555	1800	310 x 370 x 205	230 x 225	15

YATO	(W)	(mm)	PLATE (mm)	(kg)
YG-04556	1800	310 x 370 x 215	230 x 225	15



YATO	(W)	(mm)	PLATE (mm)	(kg)
YG-04558	2200	440 x 370 x 190	345 x 230	18



YATO	(W)	(mm)	PLATE (mm)	(kg)
YG-04557	2200	440 x 370 x 190	345 x 230	18

**Gas-fired grill**

- DE Gasgrill
- RU Газовый гриль
- UK Газовий гриль
- LT Dujinis grilis
- LV Gāzes grils
- CS Plynový gril
- SK Plynový gril
- HU Gázgrill
- RO Grătar cu gaz
- ES Barbacoa de gas
- FR Barbecue au gaz
- PT Churrasqueira a gás
- IT Barbecue a gas
- BG Газов грил
- EL Σχάρα αερίου
- ZH 燃气烧烤炉

9 kW	x3	3 LED KNOBS	2 SHELVES WITH HANGERS
------	----	----------------	------------------------------



YATO	(kW)	(mm)	GRATE (mm)	LATTICE (mm)	(kg)
YG-20001	9	1220 x 590 x 1120	570 x 410	570 x 120	26.5



YATO	(W)	(mm)	PLATE (mm)	(kg)
YG-04560	3600	580 x 360 x 190	485 x 230	24



**Gas-fired grills**

- |                     |                         |
|---------------------|-------------------------|
| DE Gasgrills        | RO Grătare cu gaz       |
| RU Газовые грили    | ES Barbacoas de gas     |
| UK Газові грилі     | FR Barbécues à gaz      |
| LT Dujiniai griliai | PT Churrasqueiras a gás |
| LV Gāzes grili      | IT Barbecue a gas       |
| CS Plynové grily    | BG Газови грилове       |
| SK Plynové grily    | EL Σχάρες αερίου        |
| HU Gázgrillek       | ZH 燃气烤架                 |

SS  
STAINLESS STEEL

360°  
4x

4x  
BRAKE



**YG-20002**

9.0 kW  
+2.5 kW

3+1



**YG-20011**

12.0 kW  
+2.5 kW

4+1



YATO	(kW)	(mm)	GRATE (mm)	LATTICE (mm)	(kg)
YG-20002	11.5	1220 x 570 x 1120	600 x 420 (2 pcs.)	570 x 120	32
YG-20011	14.5	1330 x 570 x 1120	700 x 420 (3 pcs.)	675 x 120	36

**Gas-fired grills**

- |                     |                         |
|---------------------|-------------------------|
| DE Gasgrills        | RO Grătare cu gaz       |
| RU Газовые грили    | ES Barbacoas de gas     |
| UK Газові грилі     | FR Barbécues à gaz      |
| LT Dujiniai griliai | PT Churrasqueiras a gás |
| LV Gāzes grili      | IT Barbecue a gas       |
| CS Plynové grily    | BG Газови грилове       |
| SK Plynové grily    | EL Σχάρες αερίου        |
| HU Gázgrillek       | ZH 燃气烤架                 |

4+1

360°  
4x

360°  
4x

4x  
BRAKE



**YG-20012** 14.0 kW  
+2.0 kW



YATO	(kW)	(mm)	GRATE (mm)	LATTICE (mm)	(kg)
YG-20012	16	1330 x 630 x 1130	680 x 440 (3 pcs.)	660 x 160	40.5



**YG-20013** 14.0 kW  
+3.5 kW



YATO	(kW)	(mm)	GRATE (mm)	LATTICE (mm)	(kg)
YG-20013	17.5	1470 x 580 x 1270	650 x 460 (2 pcs.)	680 x 170	59.5

### Gas-fired grill

- DE Gasgrill
- RU Газовый гриль
- UK Газовий гриль
- LT Dujinis grilis
- LV Gāzes grils
- CS Plynový gril
- SK Plynový gril
- HU Gázgrill
- RO Grătar cu gaz
- ES Barbacoa de gas
- FR Barbecue au gaz
- PT Churrasqueira a gás
- IT Barbecue a gas
- BG Газов грил
- EL Σχάρα αερίου
- ZH 燃气烧烤炉



**12+2.2 kW**

**4+1**

**SS**  
STAINLESS STEEL  
STAL NERDZEWNA

**360°**

**4x**

**4x**  
**4x**  
BRAKE  
HAMULEC



YATO	(kW)	(mm)	GRATE (mm)	LATTICE (mm)	(kg)
YG-20017	14.2	1410 x 550 x 1130	700 x 420	675 x 120	41.5

### Gas-fired grill

- DE Gasgrill
- RU Газовый гриль
- UK Газовий гриль
- LT Dujinis grilis
- LV Gāzes grils
- CS Plynový gril
- SK Plynový gril
- HU Gázgrill
- RO Grătar cu gaz
- ES Barbacoa de gas
- FR Barbecue au gaz
- PT Churrasqueira a gás
- IT Barbecue a gas
- BG Газов грил
- EL Σχάρα αερίου
- ZH 燃气烧烤炉



**18+2.2 kW**

**6+1**

**SS**  
STAINLESS STEEL  
STAL NERDZEWNA

**360°**

**4x**

**4x**  
**4x**  
BRAKE  
HAMULEC



YATO	(kW)	(mm)	GRATE (mm)	LATTICE (mm)	(kg)
YG-20017	20.2	1440 x 570 x 1130	780 x 420	790 x 120	39.5

### Gas-fired grill 2 in 1

- DE Gasgrill
- RU Газовый гриль
- UK Газовий гриль
- LT Dujinis grilis
- LV Gāzes grils
- CS Plynový gril
- SK Plynový gril
- HU Gázgrill
- RO Grătar cu gaz
- ES Barbacoa de gas
- FR Barbecue au gaz
- PT Churrasqueira a gás
- IT Barbecue a gas
- BG Газов грил
- EL Σχάρα αερίου
- ZH 燃气烧烤炉



**6+2.2 kW**

**2+1**

**SS**  
STAINLESS STEEL

**360°**

**4x**

**4x**  
**4x**  
BRAKE



YATO	(kW)	(mm)	GRATE (mm)	LATTICE (mm)	(kg)
YG-20030	8.2	1620 x 660 x 1130	900 x 420	900 x 120	54

### Cast iron plate for gas grills

DE Gusseisenplatte für Gasgrills  
RU Плита чугунная для газовых грилей  
UK Чавунна пластина для газових грилів  
LT Ketaus plokštė dujinėms kepsninėms  
LV Čuguna plāksne gāzes restēm  
CS Litinová deska pro plynové grily  
SK Liatinová platňa pre plynové grily  
HU Őntöttvas lemez gázrácsokhoz  
RO Placă de fontă pentru grătare pe gaz  
ES Placa de hierro fundido para parrillas de gas  
FR Plaque en fonte pour grils à gaz  
PT Placa de ferro fundido para churrasqueiras a gás  
IT Piastra in ghisa per grill a gas  
BG Чугунена плоча за газова скара  
EL Πλάκα από χυτοσίδηρο για γκριλ αερίου  
ZH 燃气烧烤炉用铸铁板

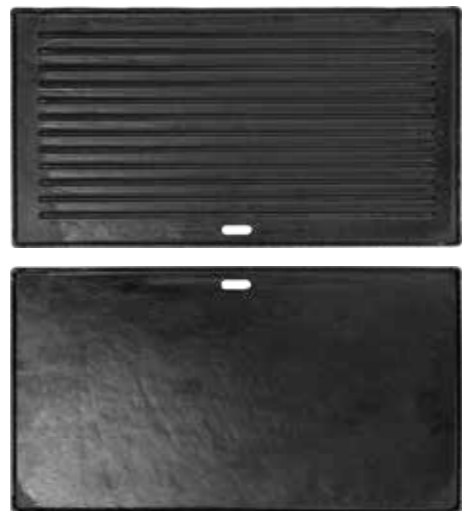

220x410 mm

CAST IRON  
ZELIWO

2.7 kg

YATO	(mm)	FOR:
YG-20020	220 x 410	YG-20002, YG-20011, YG-20017, YG-20030

### Automatic rotisserie for gas grill

DE - Automatischer Spieß für Gasgrill  
RU - Автоматический вертел для газового гриля  
UK - Автоматичний рожен для газового гриля  
LT - Automatinis dujinis kepsninis iešmas  
LV - Automātiskais iešms gāzes grilam  
CS - Automatický rožeň k plynovému grilu  
SK - Automatický ražeň na plynový gril  
HU - Automatikus nyárs gázgrillhez

RO - Rotisr automat pt. grătare pe gaz  
ES - Espetón automático para parrilla de gas  
FR - Rôtissoire automatique pour barbecue à gaz  
PT - Espeto automático para churrasqueira a gás  
IT - Girarosto automatico per barbecue a gas  
BG - Автоматичен барбекю-шиш за газова скара  
EL - Σούβλα με μοτέρ για ψησταριές υγραερίου  
ZH - 烤炉配件

4W

SS  
STAINLESS STEEL  
STAL NIERDZEWNIA



YATO	BARBECUE (mm)	HANDLE (mm)	ENGINE (mm)	FOR:
YG-20021	825	110	70	YG-20001, YG-20012, YG-20013, YG-20014

### Barbecue grill protective covers

DE Schutzhüllen für Gasgrills  
RU Чехлы для барбекю  
UK Чохли на грилі  
LT Grilių dėklai  
LV Griļu pārvalki  
CS Kryty na grily  
SK Kryty pre grily  
HU Grill takaróponyva  
RO Huse de protecție pentru grătare  
ES Fundas para barbacoas  
FR Housses pour barbecue  
PT Capas para churrasqueiras  
IT Copertura per barbecue  
BG Калъфи за грилове  
EL Καλύμματα για σχάρες  
ZH 烧烤架防护罩



x2  
HOOK  
FASTENER  
RZEP

PCV

600D  
POLYESTER  
POLIESTER

YATO	(mm)	FOR:
YG-20050	1300 x 600 x 1050	YG-20001, YG-20002, YG-20011
YG-20051	1500 x 650 x 1050	YG-20012, YG-20013, YG-20017, YG-20030

### Single and dual deep fryers

DE Einzel- und Doppelfritteusen  
RU Однoчные и двойные фритюрницы  
UK Одиначні і подвійні фритюрниці  
LT Pavienės ir dvigubos fritiūrinės  
LV Fri katli vienkāršie un dubultie  
CS Jednotlivé i dvojité fritězy  
SK Jednoduché a dvojité fritězy  
HU Szimpla és dupla olajsütők  
RO Friteuze

ES Freidoras de cuba simple y doble  
FR Friteuses à simple et double cuve  
PT Fritadeiras simples e duplas  
IT Friggitrici singole e doppie  
BG Фритюрници единични и двойни  
EL Μονές και διπλές φριτέζες  
ZH 电炸炉

°C  
60-200  
SS  
STAINLESS STEEL  
PC  
PANEL COVER  
COLD AREA



### Single deep fryers

YATO	(W)	MAX. (l)*	BASKET (mm)	(mm)	(kg)
YG-04608	2000	3.5	210 x 125 x 95	430 x 200 x 290	4.5
YG-04609	2000	5	210 x 125 x 135	430 x 200 x 335	5.5
YG-04610	3000	6	210 x 190 x 95	430 x 285 x 285	6
YG-04616	3300	8.5	210 x 190 x 150	430 x 285 x 335	6.5
YG-04617	5000	11	240 x 220 x 120	490 x 285 x 360	8



### Dual deep fryers

- separate switches and thermostats for each of the two chambers

YATO	(W)	MAX. (l)*	BASKET (mm)	(mm)	(kg)
YG-04620	2 x 2000	2 x 3.5	215 x 120 x 95	425 x 410 x 290	9
YG-04621	2 x 2000	2 x 5	215 x 120 x 135	425 x 410 x 340	9.5
YG-04622	2 x 3000	2 x 6	215 x 195 x 95	425 x 580 x 305	10.5
YG-04623	2 x 3300	2 x 8	215 x 195 x 150	425 x 580 x 335	12
YG-04624	2 x 5000	2 x 11.5	240 x 220 x 110	490 x 595 x 360	15

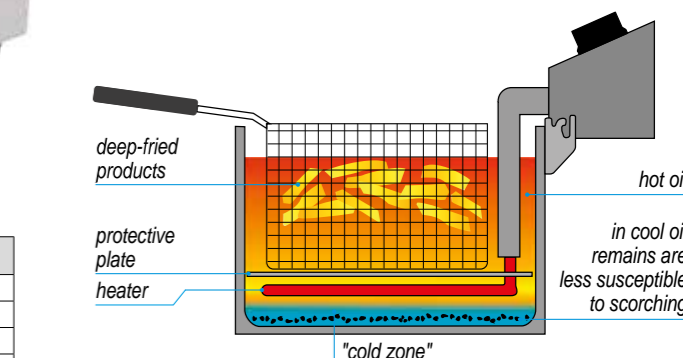

\* total capacity

### Deep fryers with a faucet

- |                                   |                                      |
|-----------------------------------|--------------------------------------|
| DE Fritteusen mit Hahn            | RO Friteuze cu robinet de golire     |
| RU Фритюрницы с краном            | ES Freidoras con grifo de vaciado    |
| UK Фритюрниця з краном            | FR Friteuses avec robinet de vidange |
| LT Fritiūrines su čiaupu          | PT Fritadeiras com torneira          |
| LV Fri katli ar krāniņu           | IT Friggitrici con rubinetto         |
| CS Fritézy s ventilem             | BG Фритюрници с кран                 |
| SK Fritézy s ventilom             | EL Φριτέζες με βρύση                 |
| HU Olajsütő olajleeresztő csappal | ZH 带龙头的电炸炉                           |



### Single deep fryers with a faucet

YATO	(W)	MAX. (l)*	BASKET (mm)	(mm)	(kg)
YG-04615	3000	6.5	210 x 190 x 90	530 x 300 x 355	7
YG-04630	5000	12	240 x 220 x 115	550 x 365 x 400	11



### Dual deep fryers with a faucet

YATO	(W)	MAX. (l)*	BASKET (mm)	(mm)	(kg)
YG-04632	2 x 3000	2 x 6	210 x 190 x 90	520 x 610 x 355	14
YG-04634	2 x 5000	2 x 12	240 x 220 x 120	550 x 730 x 400	18

\* total capacity

- °C  
60-200
- SS  
STAINLESS STEEL
- PC  
PANEL COVER
- COLD  
AREA
- DRAINING  
TAP



YG-04630 YG-04615  
YG-04634 YG-04632

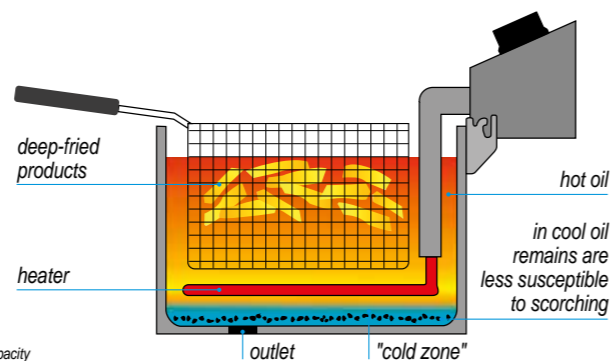

### Freestanding deep fryers

- |                                   |                                   |
|-----------------------------------|-----------------------------------|
| DE Freistehende Fritteusen        | RO Friteuze adânci                |
| RU Автономные фритюрницы          | ES Freidoras independientes       |
| UK Автономні фритюрниця           | FR Friteuses indépendantes        |
| LT Laisvai pastatomos fritiūrines | PT Fritadeiras com pés            |
| LV Brīvi stāvoši fri katli        | IT Friggitrici autoportanti       |
| CS Volně stojící fritéza          | BG Свободно стоящи фритюрници     |
| SK Stojanové fritézy              | EL Φριτέζες ελεύθερης τοποθέτησης |
| HU Szabadon álló olajsütő         | ZH 立式电炸炉                          |

- °C  
60-200
- SS  
STAINLESS STEEL
- PC  
PANEL COVER
- COLD  
AREA
- DRAINING  
TAP

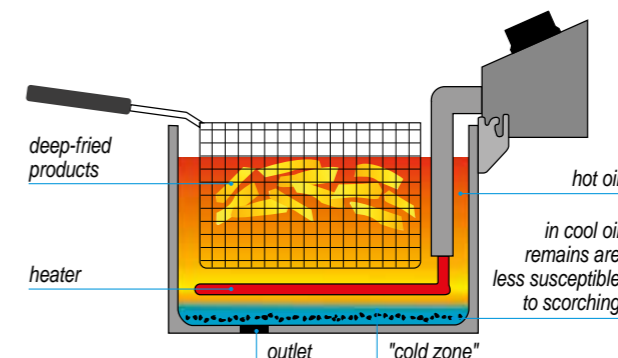

YG-04636



YG-04638

YATO	(W)	MAX. (l)*	BASKET (mm)	CABINET (mm)	(mm)	(kg)
YG-04636	5000	11.5	240 x 225 x 115	315 x 370 x 390	520 x 365 x 935	16
YG-04638	2 x 5000	2 x 11.5	240 x 225 x 115	680 x 370 x 390	520 x 730 x 900	31

\* total capacity

### Frying machines

- DE Multibräter
- RU Жарительницы
- UK Жаровня
- LT Gruzdintuvės
- LV Cepēji
- CS Smažicí stroje
- SK Zariadenia na vysmážanie
- HU Olajsütők
- RO Maşini de prăjit
- ES Freidoras
- FR Friteuses
- PT Fritadeiras
- IT Friggitrici
- BG Специални фритюрници
- EL Ανατρελόµενα τηγάνια
- ZH 电炸炉



YG-04641



YG-04640

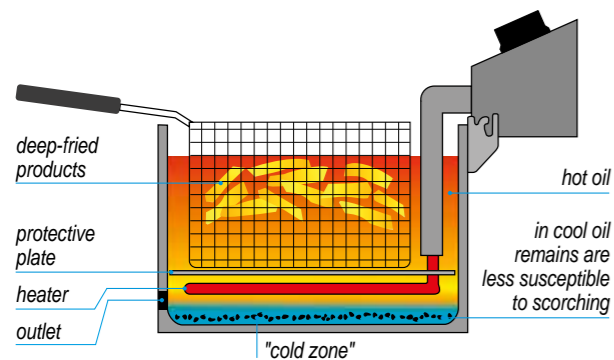
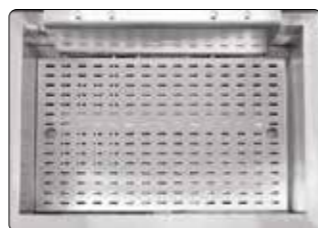
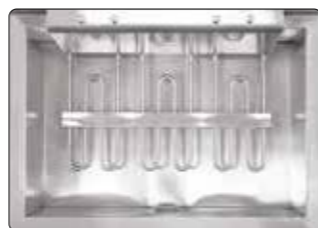

YATO	(W)	MAX. (l)*	BASKET (mm)	(mm)	(kg)
YG-04640	6000	23	270 x 480 x 90	570 x 580 x 340	14
YG-04641	6000	26.5	270 x 480 x 90	600 x 600 x 360	15

\* total capacity

### Circulator for sous vide cooking

- DE Zirkulator zum Sous-Vide-Kochen
- RU Циркулятор для вакуумного приготовления
- UK Циркулятор для приготування їжі sous vide
- LT Sous vide virimo cirkulatorius
- LV Sous vide cirkulators
- CS Cirkulátor pro vakuované vaření
- SK Cirkulačný prístroj na varenie sous vide
- HU Sous-Vide keringető
- RO Aparat pentru gătit sous vide
- ES Circulador de inmersión sous vide
- FR Circulateur d'immersion de précision pour cuisson sous vide
- PT Circulador para cozimento a vácuo
- IT Circolatore per la cottura sous vide
- BG Циркулятор за sous vide готвене
- EL Κυκλοφορητής για sous vide μαγειρική
- ZH 真空低温烹饪器



YATO	(W)	(l)	(mm)	(kg)
YG-04730	1500	<30	28.5 x 18.2 x 14.5	2

### Insulating spheres for sous vide cooking

- DE Isolierkugeln zum Sous-Vide-Kochen
- RU Изоляционные шарики для вакуумного приготовления
- UK Ізоляційні кульки для приготування їжі sous vide
- LT Sous vide izoliaciniai virimo rutuliukai
- LV Izolācijas lodītes sous vide gatavošanai
- CS Izolační kuličky pro vakuované vaření
- SK Izolačné guľôčky na varenie sous vide
- HU Szigetelő golyók Sous-Vide keringetőhöz
- RO Bile izolante pentru gătit sous vide
- ES Pelotas para cocina sous vide
- FR Billes isolantes pour cuisson sous vide

- PT Bolas de isolamento para cozimento a vácuo
- IT Palline isolanti per la cottura sous vide
- BG Изолационни топки за sous vide готвене
- EL Μπάλες μόνωσης για sous vide μαγειρική
- ZH 真空绝缘球



YATO	(pcs.)	Ø (mm)	MAX. TEMPERATURE (°C)
YG-04735	100	20	110

- 1500W
- °C 5-99
- 0.1°C TEMP. ADJUSTMENT
- +/-0.5°C TEMP. TOLERANCE
- 0~99 h TIME SETTING
- <30L MAX CAPACITY
- WATER CIRCULATION
- MEMORY
- LCD DISPLAY
- SS STAINLESS STEEL



### Pancake maker

DE Срепесмакер  
RU Блинная  
UK Млинниця  
LT Lietinių gaminimo aparatas  
LV Pankūku cepšanas iekārta  
CS Palačinkovač  
SK Stroj na smaženie palacinek  
HU Palacsinta készítő  
RO Plită pentru clătite  
ES Срепера  
FR Crêpière  
PT Panquequeira  
IT Macchina per pancake  
BG Уред за палачинки  
EL Τηγάνι για κρέπες  
ZH 煎饼机



∅ 400 mm
PTFE
50-300 °C WORKING TEMPERATURE
3000W
SS STAINLESS STEEL



YATO	(W)	(mm)	PLATE (mm)	(kg)
YG-04680	3000	450 x 470 x 220	∅ 400 x 15	13

### Rice cookers

DE Reiskocher  
RU Рисоварки  
UK Пристрої для приготування рису  
LT Ryžių virimo įrenginys  
LV Rīsu vārietāji  
CS Zařízení k vaření rýže  
SK Zariadenia na varenie ryže  
HU Rizsfőző készülék  
RO Oală pentru gătit orezului  
ES Aparatos para cocinar arroz  
FR Cuiseurs à riz  
PT Panelas de arroz  
IT Macchina per la cottura del riso  
BG Уред за варене на ориз  
EL Συσκευές για μαγειρέμα ρυζιού  
ZH 电饭煲



SS STAINLESS STEEL
ABS
ENERGY SAVING MODE
COOKING WARMING DIODES
NON STICK POT

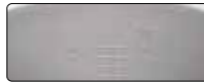

#### YG-04695

- container capacity: 16.5 l
- maximum amount of dry rice: 5.5 l (30 servings of 180 ml)
- internal dimensions of the container: ∅ 320 x 210 mm

#### YG-04696

- container capacity: 27 l
- maximum amount of dry rice: 9 l (50 servings of 180 ml)
- internal dimensions of the container: ∅ 380 x 240 mm

YATO	V (l)	(mm)	(W)
YG-04695	16.5	480 x 380 x 380	1950
YG-04696	27	560 x 490 x 405	2850



### Steel food transport containers

DE Transport-Thermobehälter aus Stahl  
RU Термосы для транспортировки  
UK Сталеві транспортні термоси  
LT Plieniniai transportavimo termosai  
LV Transportēšanas termosī, tērauda  
CS Přepavní stylové termosky  
SK Prepravné ocelové termosky  
HU Acél szállítótermoszok  
RO Container etanș pentru transport  
ES Contenedores isotérmicos de acero  
FR Récipients isothermes en acier  
PT Garrafas térmicas de aço para transporte  
IT Thermos da trasporto in acciaio  
BG Стоманени термоси за транспортиране  
EL Θερμομονωτικές φιάλες μεταφοράς από ανοξείδωτο χάλυβα  
ZH 保温桶



SS443/201 STAINLESS STEEL
THERMAL ISOLATION
80-68 °C / 0-6 °C
8h
DECOMPRESSION VALVE
SILICONE GASKET
RUBBER BOTTOM PAD
x2 HANDLES
x6 CLIPS
DOUBLE WALL

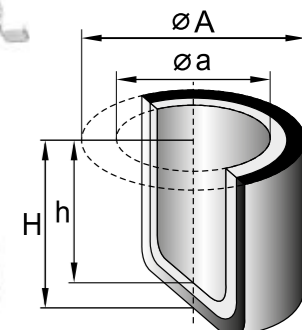

YATO	V (l)	∅ A (mm)	∅ a (mm)	H (mm)	h (mm)
YG-09200	10	355	300	240	165
YG-09201	15	355	300	300	210
YG-09202	20	355	300	380	300

YATO	V (l)	∅ A (mm)	∅ a (mm)	H (mm)	h (mm)
YG-09203	25	355	300	450	375
YG-09204	35	355	300	590	510
YG-09205	50	505	450	390	320

### Thermally insulated food transport containers

DE Thermobehälter für den Transport von Lebensmitteln  
RU Термосы для транспортировки пищи  
UK Термос для транспортування їжі  
LT Maisto transportavimo termosai  
LV Pārtikas transportēšanas termosī  
CS Termosky k přepravě potravin  
SK Prepravné termosky pre potraviny  
HU Ételszállító termoszok  
RO Vas izoterm pentru transportul alimentelor  
ES Contenedores isotérmicos transporte de alimentos  
FR Conteneurs isothermes pour le transport d'aliment  
PT Garrafas térmicas para transporte de alimentos

IT Thermos per il trasporto di alimenti  
BG Термоси за транспортиране на храна  
EL Θερμομονωτικές φιάλες για μεταφορά τροφίμων  
ZH 保温桶

SS STAINLESS STEEL
PE
DECOMPRESSION VALVE
SILICONE GASKET
THERMAL ISOLATION
85-80 °C / -3-0 °C
4h
x2 HANDLES
x4 CLIPS

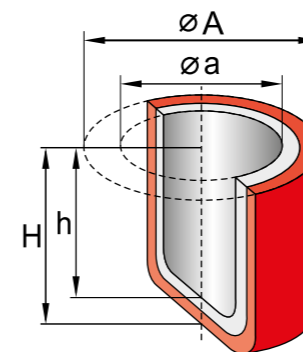

YATO	V (l)	∅ A (mm)	∅ a (mm)	H (mm)	h (mm)
YG-09225	15	335	280	300	240
YG-09226	30	410	350	380	320
YG-09227	48	465	405	445	380

### Thermally insulated catering container GN 1/1

DE Thermoisolierte Cateringbehälter GN 1/1  
RU Контейнер с термоизоляцией GN 1/1  
UK Кейтеринговий теплоізоляційний контейнер GN 1/1  
LT Termoizoliacinis maisto pervežimo konteineris GN 1/1  
LV Kateringā termoss GN 1/1  
CS Cateringová termoizolační nádoba GN 1/1  
SK Termoizolačná cateringová nádoba GN 1/1  
HU GN 1/1 thermo láda  
RO Recipient termoizolant GN 1/1

ES Contenedores isotérmicos de hostelería GN 1/1  
FR Récipient isotherme pour la restauration GN 1/1  
PT Recipiente isolado para restauração GN 1/1  
IT Contenitore termoisolante per il catering GN 1/1  
BG Изотермичен контейнер GN 1/1  
EL Δοχείο θερμομόνωσης GN 1/1 για κέττερινγκ  
ZH 保温桶



**GN 1/1** **PE** **x4 CLIPS**

85-80°C  
-3-0°C  
4h

THERMAL ISOLATION



YATO	V (l)	(mm)	INTERIOR (mm)
YG-09250	30	610 x 410 x 310	510 x 300 x 200

### Thermally insulated catering container GN 1/1

DE Thermoisolierte Cateringbehälter GN 1/1  
RU Контейнер с термоизоляцией GN 1/1  
UK Кейтеринговий теплоізоляційний контейнер GN 1/1  
LT Termoizoliacinis maisto pervežimo konteineris GN 1/1  
LV Kateringā termoss GN 1/1  
CS Cateringová termoizolační nádoba GN 1/1  
SK Termoizolačná cateringová nádoba GN 1/1  
HU GN 1/1 thermo láda  
RO Recipient termoizolant GN 1/1  
ES Contenedores isotérmicos de hostelería GN 1/1  
FR Récipient isotherme pour la restauration GN 1/1  
PT Recipiente isolado para restauração GN 1/1  
IT Contenitore termoisolante per il catering GN 1/1

BG Изотермичен контейнер GN 1/1  
EL Δοχείο θερμομόνωσης GN 1/1 για κέττερινγκ  
ZH 保温桶



**GN 1/1** **40L** **30mm WALL THICKNESS**

85-80°C  
-3-0°C  
4h

THERMAL ISOLATION

PIOCELAN **LID**



YATO	V (l)	(mm)	INTERIOR (mm)
YG-09210	40	600 x 400 x 283	540 x 340 x 222

### Thermally insulated catering cabinet

DE Thermoisolierte Cateringbehälter  
RU Термоконтейнер для перевозки  
UK Кейтеринговий теплоізоляційний контейнер  
LT Termoizoliacinis maisto pervežimo konteineris  
LV Kateringā termoss  
CS Cateringová termoizolační nádoba  
SK Termoizolačná cateringová nádoba  
HU Thermo láda  
RO Container termoizolant pentru transport  
ES Contenedores isotérmicos para restaurantes  
FR Récipients isothermes pour la restauration  
PT Recipiente isolado para restauração  
IT Contenitore termoisolante per il catering  
BG Изотермичен контейнер за кетъринг

EL Δοχείο θερμομόνωσης για κέττερινγκ  
ZH 保温餐饮柜

**90L** **PE** **1/1 GN** **1/2 GN** **1/3 GN**

x6 (65mm)  
x4 (100mm)  
x3 (150mm)

x8 (100mm)  
x4 (150mm)

x12 (100mm)  
x9 (150mm)  
x6 (200mm)

80-68°C  
0-6°C  
4h

THERMAL ISOLATION

**x2 HANDLES** **DECOMPRESSION VALVE**



YATO	(mm)
YG-09245	477 x 680 x 620

• equipped with 12 guides that make it match the following GN containers:  
- 1/1, 65 mm high – 6 pcs.  
- 1/1, 100 mm high – 4 pcs.  
- 1/1, 150 mm high – 3 pcs.  
- 1/2, 100 mm high – 8 pcs.  
- 1/2, 150 mm high – 4 pcs.  
- 1/3, 100 mm high – 12 pcs.  
- 1/3, 150 mm high – 9 pcs.  
- 1/3, 200 mm high – 6 pcs.

### Cart for thermally insulated cabinet

DE Wagen für thermoisolierte Behälter  
RU Подставка для термоконтейнера на колесах  
UK Візок для термоізоляційного контейнера  
LT Termoizoliacinio konteinerio vežimėlis  
LV Ratiņi kateringā termosam  
CS Vozík na termoizolační nádobu  
SK Vozík pre termoizolačné nádoby  
HU Thermo láda szállító kocsi  
RO Platformă cu roți  
ES Carro portacontenedores isotérmicos  
FR Chariot pour conteneurs isothermes  
PT Carrinho para recipientes térmicos

IT Carrello per il contenitore termoisolante  
BG Количка за изотермичен контейнер  
EL Καροτσάκι για δοχεία θερμομόνωσης  
ZH 保温柜推车

**PP** **x2 YG-09245 MAX LOAD** **360° 2x** **FOR: YG-09245**



YATO	(mm)	FOR:
YG-09246	710 x 530 x 230	YG-09245

### Thermally insulated beverage dispenser

DE Thermoisolierte Transportbehälter  
RU Термоконтейнеры для транспортировки  
UK Транспортні термоізоляційні ємності  
LT Termoizoliaciniai maisto transportavimo konteineriai  
LV Transportēšanas termosi  
CS Přepravní termoizolační nádoby  
SK Prepravné termoizolačné nádoby  
HU Thermo szállító ládák  
RO Containere termoizolante pentru băuturi  
ES Contenedores isotérmicos de transporte  
FR Conteneurs isothermes de transport  
PT Recipientes térmicos para transporte  
IT Contenitori da trasporto termoisolanti  
BG Изотермични контейнери за транспортиране  
EL Δοχείο θερμομόνωσης μεταφοράς  
ZH 饮料保温分配器

**x2 HANDLES** **80-72°C** **0-4°C** **4h** **THERMAL ISOLATION** **PE**



YATO	V (l)	(mm)	INTERIOR (mm)
YG-09249	9	430 x 230 x 470	330 x 175 x 265

### Waiter trolleys

DE Kellnerwagen  
RU Тележки для официантов  
UK Візки для офіціантів  
LT Padavėjo vežimėlis  
LV Viesmīļu ratiņi  
CS Číšnícké vozíky  
SK Čašnické vozíky  
HU Pincérkocsik  
RO Cărucioare pentru servire  
ES Carros de camarero  
FR Table roulante  
PT Carrinhos de garçom  
IT Carrelli per camerieri

BG Ресторантски колички за сервиране  
EL Καροτσάκια σερβιτόρων  
ZH 服务车

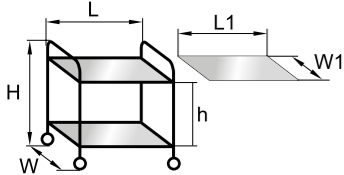

**x2**  
SHELVES

#### Two-shelf waiter trolley

YATO 	L x W x H (mm)	L1 x W1 (mm)	h (mm)
YG-09090	860 x 530 x 950	820 x 500	570

**x3**  
SHELVES

#### Three-shelf waiter trolley

YATO 	L x W x H (mm)	L1 x W1 (mm)	h (mm)
YG-09091	860 x 530 x 950	820 x 500	270

### Waiter trolleys

DE Servierwagen  
RU Сервировочные тележки  
UK Сервісні візки  
LT Serviravimo vežimėliai  
LV Servēšanas ratiņi  
CS Servisní vozíky  
SK Vozíky na servírovanie  
HU Felszolgáló kocsik  
RO Cărucioare din oțel inoxidabil  
ES Carros de servicio  
FR Chariots de service  
PT Carrinhos de serviço  
IT Carrelli di servizio  
BG Ресторантски колички за съдове  
EL Καροτσάκια σέρβις  
ZH 服务车

**x2**  
SHELVES

#### Two-shelf waiter trolley

YATO 	L x W x H (mm)	L1 x W1 (mm)	h (mm)
YG-09095	950 x 500 x 950	890 x 495	600

**x3**  
SHELVES

#### Three-shelf waiter trolley

YATO 	L x W x H (mm)	L1 x W1 (mm)	h (mm)
YG-09096	950 x 500 x 950	890 x 495	280

**x2**  
SHELVES

#### Deep two-shelf waiter trolley

YATO 	L x W x H (mm)	L1 x W1 (mm)	h (mm)
YG-09099	950 x 500 x 950	820 x 430	500

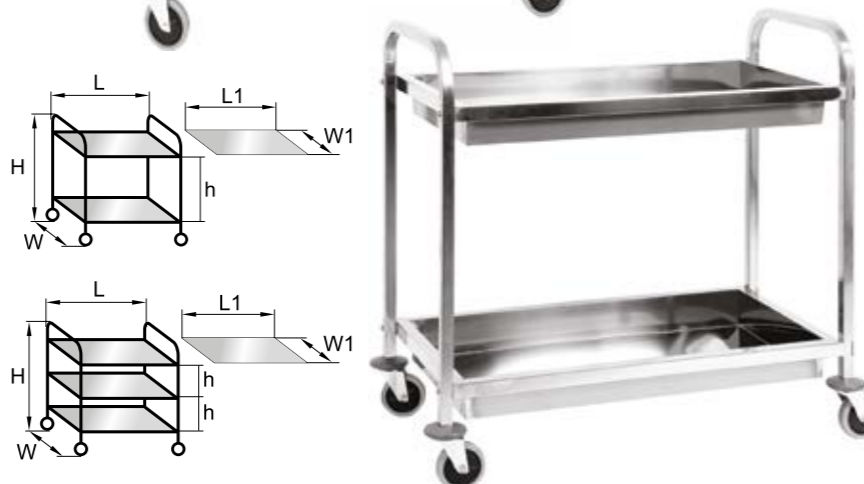

### Service trolley

DE Servierwagen  
RU Сервисная тележка  
UK Сервісний візок  
LT Serviravimo vežimėlis  
LV Servēšanas ratiņi  
CS Servisní vozík  
SK Vozík na servírovanie  
HU Felszolgáló kocsi  
RO Cărucior pentru debarasat cu trei polițe  
ES Carro de servicio  
FR Chariot de service  
PT Carrinho de serviço  
IT Carrello di servizio  
BG Ресторантска количка за съдове  
EL Καροτσάκι σέρβις  
ZH 服务车

YATO 	(mm)
YG-09100	1040 x 510 x 980

### Containers for service trolley

DE Behälter für Servierwagen  
RU Контейнеры для сервисной тележки  
UK Контейнери для сервісного візка  
LT Serviravimo vežimėlio indai  
LV Trauī servēšanas ratiņiem  
CS Nádobys na servisní vozík  
SK Nádobys pre vozík na servírovanie  
HU Tartályok felszolgáló kocsihoz  
RO Containere pentru cărucior de debarasare

YATO 	(mm)	FOR:
YG-09104	330 x 230 x 175	YG-09100
YG-09105	340 x 225 x 440	YG-09100

### Service trolley

DE Servierwagen  
RU Сервисная тележка  
UK Сервісний візок  
LT Serviravimo vežimėlis  
LV Servēšanas ratiņi  
CS Servisní vozík  
SK Vozík na servírovanie  
HU Felszolgáló kocsi  
RO Cărucior pentru debarasat cu trei polițe  
ES Carro de servicio  
FR Chariot de service  
PT Carrinho de serviço  
IT Carrello di servizio  
BG Ресторантска количка за съдове  
EL Καροτσάκι σέρβις  
ZH 服务车

YATO 	(mm)
YG-09101	870 x 435 x 905

### Containers for service trolley

DE Behälter für Servierwagen  
RU Контейнеры для сервисной тележки  
UK Контейнери для сервісного візка  
LT Serviravimo vežimėlio indai  
LV Trauī servēšanas ratiņiem  
CS Nádobys na servisní vozík  
SK Nádobys pre vozík na servírovanie  
HU Tartályok felszolgáló kocsihoz

YATO 	(mm)	INTERIOR (mm)	FOR:
YG-09102	540 x 380 x 135	460 x 330 x 130	YG-09101
YG-09103	540 x 380 x 205	460 x 330 x 200	YG-09101
YG-09106	275 x 195 x 310	265 x 185 x 305	YG-09101



ES Recipientes para carro de servicio  
FR Conteneurs pour chariot de service  
PT Recipientes para carrinho de serviço  
IT Contenitori per il carrello di servizio  
BG Контейнери за ресторантска количка  
EL Δοχείο για καροτσάκια σέρβις  
ZH 服务车收集盒



**PP**

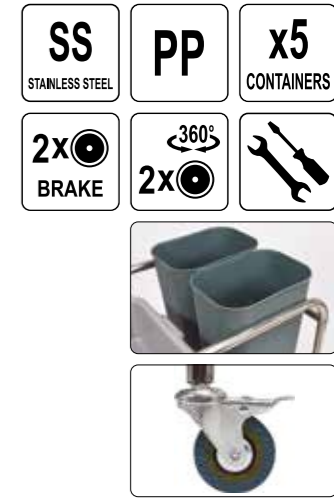

RO Containere pentru cărucior de debarasare  
ES Recipientes para carro de servicio  
FR Conteneurs pour chariot de service  
PT Recipientes para carrinho de serviço  
IT Contenitori per il carrello di servizio  
BG Контейнери за ресторантска количка  
EL Δοχείο για καροτσάκια σέρβις  
ZH 服务车收集盒



**PP**

### Transport trolleys

- |   |                            |
|---|----------------------------|
| DE Transportwagen                                     | ES Carro de transporte     |
| RU Тележки-шпильки                                    | FR Chariot de transport    |
| UK Транспортні візки                                  | IT Carrelli da trasporto   |
| LT Transportavimo vežimėliai                          | BG Транспортни колички     |
| LV Transportēšanas ratiņi                             | EL Καροτσάκια μεταφοράς    |
| CS Převážní vozíky                                    | PT Carrinhos de transporte |
| SK Prepravné vozíky                                   | ZH 手推车                     |
| HU Tálcaszállító kocsik                               |                            |
| RO Cărucioare pentru transportul tăvilor și GN-urilor |                            |

<b>SS 201</b> STAINLESS STEEL	max <b>40kg</b> SHELF	80 mm	<b>2x</b> BRAKE	TRANSPORT LOCK	
----------------------------------	-----------------------------	----------	--------------------	-------------------	--





**15x**  
1/1GN

**30x**  
1/2GN

Guides M



The guides enables adjusting the spacing between containers



Guides L

**15x**  
BAKERY  
CONTAINERS

**15x**  
TRAY  
400x600 mm

#### Transport trolley for GN containers

<b>YATO</b> <sup>®</sup>	(mm)
YG-09070	380 x 550 x 1700

#### Gastronomic trolley for waiter's trays and baking trays

<b>YATO</b> <sup>®</sup>	(mm)
YG-09072	470 x 620 x 1700

### Platform trolley

- |                           |                           |
|---------------------------|---------------------------|
| DE Plattformwagen         | ES Carro de plataforma    |
| RU Платформенная тележка  | FR Chariot à plate-forme  |
| UK Платформний візок      | PT Carrinho de plataforma |
| LT Platforminis vežimėlis | IT Carrello a pianale     |
| LV Platformas ratiņi      | BG Платформена количка    |
| CS Platformový vozík      | EL Καροτσάκι πλατφόρμας   |
| SK Plošinový vozík        | ZH 折叠手推车                  |
| HU Platform kocsik        |                           |
| RO Cărucior platformă     |                           |

<b>SS 201</b> STAINLESS STEEL
max <b>150kg</b>
360° <b>2x</b>
FOLDABLE HANDLE

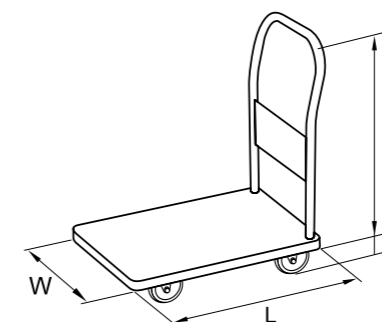

<b>YATO</b> <sup>®</sup>	L x W (mm)	H (mm)	h (mm)
YG-09080	740 x 440	725	125

### Assemblable work tables

DE Arbeitstische – zusammengeschaubt  
RU Столы рабочие – сборные  
UK Болтові робочі столи  
LT Susukami darbataliai  
LV Darba galdi, saskrūvējami  
CS Pracovní montované stoly  
SK Pracovné stoly skladacie  
HU Csavarozott munkaasztalok  
RO Mese de lucru  
ES Mesa de trabajo para cocina profesional  
FR Table avec un plan de travail pour cuisine  
PT Mesas de trabalho montadas  
IT Banchi da lavoro avvitati  
BG Сглобяеми работни маси  
EL Περιτρεφόμενα τραπέζια εργασίας  
ZH 不锈钢工作台

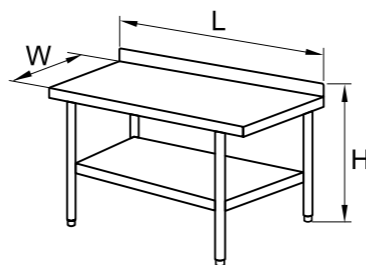
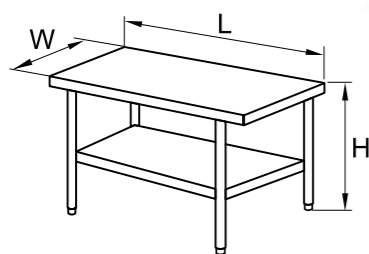

### Central tables with undershelf

YATO	L (mm)	W (mm)	H (mm)
YG-09000	800	600	850
YG-09001	1000	600	850
YG-09002	1200	600	850
YG-09003	1400	600	850
YG-09004	1500	600	850
YG-09005	1600	600	850
YG-09006	800	700	850
YG-09010	1000	700	850
YG-09011	1200	700	850
YG-09012	1400	700	850
YG-09013	1500	700	850
YG-09014	1600	700	850

### Wall tables with undershelf - with a 100 mm backsplash

YATO	L (mm)	W (mm)	H (mm)
YG-09020	800	600	850+100
YG-09021	1000	600	850+100
YG-09022	1200	600	850+100
YG-09023	1400	600	850+100
YG-09024	1500	600	850+100
YG-09025	1600	600	850+100
YG-09030	800	700	850+100
YG-09031	1000	700	850+100
YG-09032	1200	700	850+100
YG-09033	1400	700	850+100
YG-09034	1500	700	850+100
YG-09035	1600	700	850+100

**SS 201**  
STAINLESS STEEL

max **150 kg**  
TABLE

max **35 kg**  
SHELF

ADJUSTABLE FEET

DETERGENT



### Slatted racks

DE Lagerregale  
RU Сетчатые стеллажи  
UK Ажурні стелажі  
LT Azūriniai stelažai  
LV Azūra plauktu stelāžas

CS Transparentní regály  
SK Dierované regály  
HU Állványos polc rendszer  
RO Rafturi tip plasă  
ES Estanterías con baldas

FR Étagères ajourées  
PT Prateleiras vazadas  
IT Scaffalature traforate  
BG Ажурни рафтове

EL Διάφανα ράφια  
ZH 置物架

**Cr**  
CHROME PLATED

### Shelves

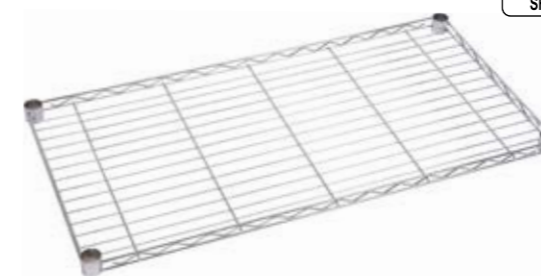

max **200 kg**  
SHELF

**8+2**  
FIXING  
WEDGES

YATO	(mm)	CONFIGURATIONS OF ASSEMBLED RACK	(mm)
YG-09050	600 x 457	4 x YG-09050 + 4 x YG-09065	600 x 457 x 1880
YG-09051	906 x 457	4 x YG-09051 + 4 x YG-09065	906 x 457 x 1880
YG-09052	1210 x 457	4 x YG-09052 + 4 x YG-09065	1210 x 457 x 1880
YG-09053	1520 x 457	4 x YG-09053 + 4 x YG-09065	1520 x 457 x 1880
YG-09054	600 x 610	4 x YG-09054 + 4 x YG-09065	600 x 610 x 1880
YG-09055	906 x 610	4 x YG-09055 + 4 x YG-09065	906 x 610 x 1880
YG-09056	1060 x 610	4 x YG-09056 + 4 x YG-09065	1060 x 610 x 1880
YG-09057	1210 x 610	4 x YG-09057 + 4 x YG-09065	1210 x 610 x 1880
YG-09058	1520 x 610	4 x YG-09058 + 4 x YG-09065	1520 x 610 x 1880
YG-09059	1820 x 610	4 x YG-09059 + 4 x YG-09065	1820 x 610 x 1880

### Bars

**1880 mm**

**RUBBER FOOT**

**FOR:**  
YG-09050, YG-09051  
YG-09052, YG-09053  
YG-09054, YG-09055  
YG-09056, YG-09057  
YG-09058, YG-09059

YATO	L (mm)	Ø (mm)
YG-09065	1880	25.4

### Hanging shelves with rim

DE Hängeregale mit Rand  
RU Навесные полки с бортиком  
UK Навісні полиці з бортиками  
LT Kabančios lentynos su kraštu  
LV Piekaramie plaukti ar apmali  
CS Visací police se záhybem  
SK Závesné police s okrajom  
HU Fügő polcok peremmel  
RO Polița de perete cu bordură  
ES Repisas flotantes con borde elevado  
FR Étagères murales avec bord surélevé  
PT Prateleiras suspensas com borda  
IT Mensole sospese con bordo  
BG Стенни рафтове с кант  
EL Κρεμαστά ράφια με άκρες  
ZH 不锈钢挂墙架

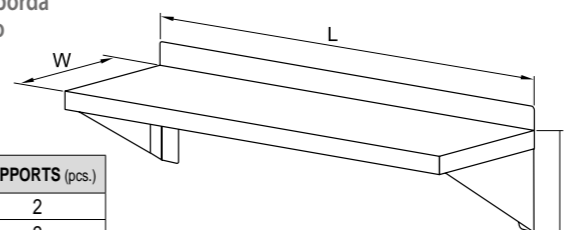

YATO	L x W x H (mm)	SUPPORTS (pcs.)
YG-09040	900 x 300 x 180	2
YG-09041	1200 x 300 x 180	2
YG-09042	1500 x 300 x 180	3
YG-09044	1800 x 300 x 180	3



### Vacuum packaging machine

DE Vakuumband-Verpackungsmaschine  
RU Вакуумная упаковочная машина  
UK Вакуумна пакувальна машина  
LT Vakuuminio pakavimo mašina  
LV Vakuuma iepakojšanas mašina  
CS Lištové vakuovací stroj  
SK Vákuový baliaci stroj  
HU Vákuumsomagoló gép  
RO Mașină de ambalat sub vid  
ES Máquina de envasado al vacío  
FR Machine d'emballage sous vide  
PT Embaladora a vácuo  
IT Macchina confezionatrice sottovuoto  
BG Вакуумна опаковъчна машина  
EL Μηχανή συσκευασίας κενού  
ZH 真空封口机

<b>700W</b>	<b>MAX 320mm</b> SEALING BAR	<b>5.0 mm</b> SEAL WIRE WIDTH	<b>SS</b> STAINLESS STEEL
<b>DUAL PUMP</b>	<b>PULS VACUUM</b>	<b>IMPULS BAG SEALING</b>	<b>MARINATE</b>



YATO	(W)	(mm)	BAR (mm)	(m <sup>3</sup> /h)
YG-09315	700	390 x 275 x 135	320	1

### Chamber packaging machine

DE Vakuunkammer-Verpackungsmaschine  
RU Камерная вакуумная упаковочная машина  
UK Камерна вакуумна пакувальна машина  
LT Kamerinis vakuuminio pakavimo aparatas  
LV Kameras vakuuma iepakotājs  
CS Komorový vakuovací stroj  
SK Komorový vákuový baliaci stroj  
HU Kamrás vákuumsomagoló gép  
RO Masina de ambalat in vid cu camera  
ES Envasadora al vacío de campana  
FR Machine d'emballage sous vide à chambre profonde  
PT Embaladora de câmara a vácuo  
IT Confezionatrice sottovuoto a camere  
BG Вакуум опаковъчна машина, камерна  
EL Κοιλιακό μηχάνημα συσκευασίας κενού  
ZH 真空封口机

<b>630W</b>	<b>MAX 300mm</b> SEALING BAR	<b>3.5 mm</b> SEAL WIRE WIDTH	<b>110/60 mm</b>	<b>SS</b> STAINLESS STEEL
-------------	---------------------------------	----------------------------------	------------------	------------------------------



YATO	(W)	(mm)	CHAMBER (mm)	BAR (mm)	(m <sup>3</sup> /h)	(kg)
YG-09317	630	430 x 360 x 345	350 x 300 x 110	300	4.6	24.4

### Vacuum packaging machines

- DE Vakuum-Verpackungsmaschinen
- RU Машины вакуумной упаковки
- UK Вакуумні пакувальні машини
- LT Vakuuminio pakavimo aparatas
- LV Vakuuma iepakotāji
- CS Vakuovací stroje
- SK Vákuové baliace stroje
- HU Vákuumsomagoló gépek
- RO Mașini de ambalare în vid
- ES Envasadoras al vacío
- FR Machines d'emballage sous vide
- PT Embaladoras a vácuo
- IT Macchine confezionatrici sottovuoto
- BG Вакуум опаковъчни машини
- EL Μηχανήματα συσκευασίας κενού
- ZH 真空封口机



### Adjustable packaging machines

YATO 	(mm)	CHAMBER (mm)	BAR (mm)	V (l)	(W)	(m <sup>3</sup> /h)
YG-09303	480 x 330 x 320h	385 x 280 x 50 (100)	260	230	370	10
YG-09304	480 x 370 x 435h	370 x 320 x 135 (185)	300	230	370	10
YG-09305	560 x 425 x 460h	450 x 370 x 170 (220)	350	230	900	20



### Free-standing packaging machines

- equipped with 4 wheels with brakes



YATO 	(mm)	CHAMBER (mm)	BAR (mm)	V (l)	(W)	(m <sup>3</sup> /h)
YG-09310	555 x 475 x 1000h	440 x 420 x 75 (125)	2 x 420	230	900	20
YG-09311	555 x 475 x 1050h	440 x 420 x 150 (200)	400	230	900	20
YG-09312	630 x 790 x 960h	720 x 480 x 150 (210)	2 x 460	230	900	20



### Bags for vacuum packaging machines

- DE Beutel für Vakuum-Verpackungsmaschinen
- RU Пакеты для вакуумных упаковочных машин
- UK Мішки для вакуумної упаковки
- LT Maišeliai vakuuminiam pakavimo aparatui
- LV Maisiņi vakuuma iepakotājiem
- CS Pytlíky do vakuovacích strojů
- SK Vrecká pre vákuové baliace stroje
- HU Tasakok vákuumsomagoló géphez
- RO Pungi pentru mașinile de ambalare în vid
- ES Bolsas para envasadoras al vacío
- FR Sacs pour machines d'emballage sous vide
- PT Sacos para embaladoras a vácuo
- IT Sacchetti per macchine confezionatrici sottovuoto
- BG Пликове за вакуум машини
- EL Σάκοι για μηχανήματα συσκευασίας κενού
- ZH 真空包装袋

x100 70 μm



### Bags for chamber packaging machines

PA/PE

### Bags for sous vide and chamber packaging machines

PA/PE SV 120°C (max)

- Recommended for preparing dishes in sous vide technology, marinating and pasteurizing.
- they can be used at temperature from -20°C to +120°C

YATO 	(mm)
YG-09330	140 x 200
YG-09331	160 x 230
YG-09332	200 x 300
YG-09333	250 x 350
YG-09334	300 x 400

YATO 	(mm)
YG-09335	140 x 200
YG-09336	160 x 230
YG-09337	200 x 300
YG-09338	250 x 350
YG-09339	300 x 400

### Industrial vacuum packaging machine

DE Industrie-Vakuum-Verpackungsmaschine  
RU Промышленная машина вакуумной упаковки  
UK Промислова вакуумна пакувальна машина  
LT Pramoninis vakuuminio pakavimo aparatas  
LV Rūpnieciskais vakuuma iepakotājs  
CS Průmyslový vakuovací stroj  
SK Priemyselný vákuový baliaci stroj  
HU Ipari vákuumcsomagoló gép  
RO Mașină de ambalare în vid industrială  
ES Envasadoras al vacío industrial  
FR Machines d'emballage sous vide industrielles  
PT Embaladora a vácuo industrial  
IT Macchina confezionatrice sottovuoto industriale  
BG Индустриална вакуум опаковъчна машина  
EL Βιομηχανικό μηχάνημα συσκευασίας κενού  
ZH 工业真空封口机



**SS**  
STAINLESS STEEL

**2x**  
**720x560**  
mm  
CHAMBER

**160**  
mm

**2x20**  
m<sup>3</sup>/h  
PUMP EFFICIENCY

**2x900W**



YATO 	(mm)	CHAMBER (mm)	BAR (mm)	V (l)	(W)	(m <sup>3</sup> /h)
YG-09307	720 x 1460 x 980h	720 x 560 x 160	2 x 600	480	2 x 900	2 x 20

### Cooling and freezing cabinets

DE Kühl- und Gefrierschränke  
RU Холодильные и морозильные шкафы  
UK Холодильні та морозильні шафи  
LT Vėsinimo ir šaldymo spintos  
LV Aukstuma skapji  
CS Chladicí a mrazicí boxy  
SK Chladné a mraziace skrine  
HU Hűtő- és fagyasztószelekreneyek  
RO Dulapuri de răcire și congelare  
ES Armarios refrigerados y de congelación  
FR Armoires réfrigérées et congélateurs  
PT Armários de refrigeração e congelamento  
IT Armadi frigoriferi e congelatori  
BG Хладилни шкафовe и фризерни  
EL Θάλαμοι ψύξης και κατάψυξης  
ZH 冷藏柜



**SS 201**  
STAINLESS STEEL

**FORCED AIR CIRCULATION**

**AUTOMATIC DEFROST**



**max 40kg**  
SHELF

**SELF CLOSING DOOR**

**LOCK**

**LED LIGHT**

**X4**  $\uparrow$  120-180 mm  
ADJUSTABLE FEET

**R290**  
REFRIGERANT

**GN 2/1**

**HEPA FILTER**



### Cooling and freezing 1-door cabinets

• 3 coated shelves

YATO 	(°C)	V (l)	(mm)	(W)	(kg)	(kWh/year)*
YG-05215	-2/+8	600	680 x 810 x 2010	195	110	887
YG-05200	-2/+8	650	740 x 830 x 2010	215	121	1081
YG-05216	-18/-22	600	680 x 810 x 2010	450	117	2738
YG-05201	-18/-22	650	740 x 830 x 2010	480	126	2351



### Cooling and freezing 2-door cabinets

• 6 coated shelves

YATO 	(°C)	V (l)	(mm)	(W)	(kg)	(kWh/year)*
YG-05220	-2/+8	1200	1340 x 810 x 2010	400	167	1716
YG-05210	-2/+8	1300	1480 x 830 x 2010	440	188	1517
YG-05221	-18/-22	1200	1340 x 810 x 2010	700	177	4238
YG-05211	-18/-22	1300	1480 x 830 x 2010	780	201	3650



\* power consumption



### Cooling tables – line 600

DE Kühlische – Linie 600  
RU Холодильные столы – линия 600  
UK Холодильні столи – лінія 600  
LT Šaldomi darbastaliai – linija 600  
LV Aukstuma galdi – sērija 600  
CS Chladicí stoly – řada 600  
SK Chladené stoly – linka 600  
HU Hűtőasztalok – 600-as sorozat  
RO Masă rece – linia 600  
ES Mesas frigoríficas – serie 600  
FR Tables de réfrigération – série 600  
PT Mesas de refrigeração – linha 600  
IT Tavoli refrigerati – linea 600  
BG Хладилни маси – линия 600  
EL Τραπεζία ψύξης – γραμμή 600  
ZH 冷冻台-600 mm



### Cooling 2-door table – line 600

- 2 coated shelves
- tabletop dimensions: 1360 x 600 mm
- adjusted height: 850-910 mm

YATO	(°C)	V (l)	(mm)	(W)	(kg)	(kWh/year)*
YG-05253	-2/+8	228	1360 x 600 x 850	215	83	913



### Cooling 3-door table – line 600

- 3 coated shelves
- tabletop dimensions: 1795 x 600 mm
- adjusted height: 845-905 mm

YATO	(°C)	V (l)	(mm)	(W)	(kg)	(kWh/year)*
YG-05258	-2/+8	339	1795 x 600 x 845	230	105	1145

\* power consumption



### Cooling tables – line 700

DE Kühlische – Linie 700  
RU Холодильные столы – линия 700  
UK Холодильні столи – лінія 700  
LT Šaldomi darbastaliai – linija 700  
LV Aukstuma galdi – sērija 700  
CS Chladicí stoly – řada 700  
SK Chladené stoly – linka 700  
HU Hűtőasztalok – 700-as sorozat  
RO Mesă rece – linia 700  
ES Mesas frigoríficas – serie 700  
FR Tables de réfrigération – série 700  
PT Mesas de refrigeração – linha 700  
IT Tavoli refrigerati – linea 700  
BG Хладилни маси – линия 700  
EL Τραπεζία ψύξης – γραμμή 700  
ZH 冷冻台-700 mm



### Cooling 2-door table – line 700

- 2 coated shelves
- lower compressor – Zanussi
- cooling agent: R600a
- tabletop dimensions: 900 x 700 mm

**R600a**  
REFRIGERANT

YATO	(°C)	V (l)	(mm)	(W)	(kg)	(kWh/year)*
YG-05270	+2/+8	240	900 x 700 x 870	170	75	830



### Cooling 3-door table – line 700

- 3 coated shelves
- lower compressor – Embraco
- cooling agent: R290
- tabletop dimensions: 1365 x 700 mm

**R290**  
REFRIGERANT

YATO	(°C)	V (l)	(mm)	(W)	(kg)	(kWh/year)*
YG-05300	+2/+8	368	1365 x 700 x 870	240	98	1294

\* power consumption



**SEE ALSO**  
shelves  
and guides

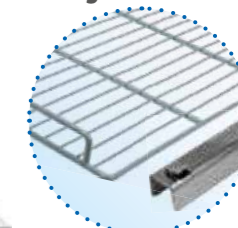

p. 87

### Cooling table with 4 drawers – line 700

DE Kühlisch mit 4 Schubladen – Linie 700  
 RU Холодильный стол с 4 выдвижными ящиками – линия 700  
 UK Холодильний стіл з 4 ящиками – лінія 700  
 LT Šaldomas darbastalis su 4 stalčiais – linija 700  
 LV Aukstuma galds ar 4 atvilknēm – sērija 700  
 CS Chladicí stůl se 4 šuplíky – řada 700  
 SK Chladený stôl s 4 zásuvkami – linka 700  
 HU Hűtőasztal 4 fiókkal – 700-as sorozat  
 RO Masă rece cu 4 sertare – linia 700  
 ES Mesas frigoríficas con 4 cajones – serie 700  
 FR Tables de réfrigération avec 4 tiroirs – série 700  
 PT Mesa de refrigeração com 4 gavetas – linha 700  
 IT Tavoli refrigerati con 4 cassetti – linea 700  
 BG Хладилна маса с 4 чекмеджета – линия 700  
 EL Τραπέζι ψύξης με 4 συρτάρια – γραμμή 700  
 ZH 4抽屜冷凍台 – 700 mm



<b>SS 201</b> STAINLESS STEEL	<b>FORCED AIR CIRCULATION</b>	<b>AUTOMATIC DEFROST</b>
<b>x4</b> DRAWER	<b>GN 1/1</b>	<b>R600a</b> REFRIGERANT
		<b>HEPA FILTER</b>



YATO	(°C)	V (l)	(mm)	(W)	(kg)	(kWh/year)*
YG-05280	+2/+8	220	900 x 700 x 870	170	90	830

### Cooling table with 6 drawers – line 700

DE Kühlisch mit 6 Schubladen – Linie 700  
 RU Холодильный стол с 6 выдвижными ящиками – линия 700  
 UK Холодильний стіл з 6 ящиками – лінія 700  
 LT Šaldomas darbastalis su 6 stalčiais – linija 700  
 LV Aukstuma galds ar 6 atvilknēm – sērija 700  
 CS Chladicí stůl se 6 šuplíky – řada 700  
 SK Chladený stôl s 6 zásuvkami – linka 700  
 HU Hűtőasztal 6 fiókkal – 700-as sorozat  
 RO Masă rece cu 6 sertare – linia 700  
 ES Mesas frigoríficas con 6 cajones – serie 700

FR Tables de réfrigération avec 6 tiroirs – série 700  
 PT Mesa de refrigeração com 6 gavetas – linha 700  
 IT Tavoli refrigerati con 6 cassetti – linea 700  
 BG Хладилна маса с 6 чекмеджета – линия 700  
 EL Τραπέζι ψύξης με 6 συρτάρια – γραμμή 700  
 ZH 6抽屜冷凍台 – 700 mm



<b>SS 201</b> STAINLESS STEEL	<b>FORCED AIR CIRCULATION</b>	<b>AUTOMATIC DEFROST</b>
<b>x6</b> DRAWER	<b>GN 1/1</b>	<b>R290</b> REFRIGERANT

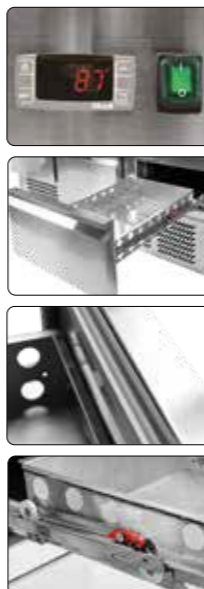

YATO	(°C)	V (l)	(mm)	(W)	(kg)	(kWh/year)*
YG-05281	+2/+8	368	1365 x 700 x 880	240	104	1294

\* power consumption



### Cooling and freezing tables with side compressor – line 700

DE Kühl- und Gefrierische mit Seitenaggregat – Linie 700  
 RU Холодильные и морозильные столы с боковым агрегатом – линия 700  
 UK Холодильні столи та морозильні камери з бічним агрегатом – лінія 700  
 LT Šaldomi darbastaliai su šoniniu agregatu – linija 700  
 LV Aukstuma galdi ar sānu agregātu – sērija 700  
 CS Chladicí a mraziací stoly s bočním agregátem – řada 700  
 SK Chladené a mraziace stoly s bočným agregátom – linka 700  
 HU Hűtő- és fagyasztóasztalok oldalsó aggregátummal – 700-as sorozat  
 RO Mese reci și de congelare cu compresor lateral – linia 700  
 ES Mesas frigoríficas y de congelación con aislamiento lateral – serie 700  
 FR Tables de réfrigération et congélateurs avec isolation latérale – série 700  
 PT Mesas de refrigeração e congelamento com agregado lateral – linha 700  
 IT Tavoli refrigerati e congelatori con aggregato laterale – linea 700  
 BG Хладилни маси и фризер маси със страничен агрегат – линия 700  
 EL Τραπέζι ψύξης και καταψύξεις με πλευρικό συσσωμάτωμα – γραμμή 700  
 ZH 自帶側壓縮機制冷冷凍台 – 700 mm



<b>SS 201</b> STAINLESS STEEL	<b>FORCED AIR CIRCULATION</b>
<b>AUTOMATIC DEFROST</b>	<b>max 40kg</b> SHELF
<b>GN 1/1</b>	<b>SELF CLOSING DOOR</b>
	<b>x4</b> 120-180 mm ADJUSTABLE FEET
<b>R290</b> REFRIGERANT	<b>HEPA FILTER</b>



#### Cooling and freezing 2-door tables with side compressor – line 700

• 2 coated shelves

YATO	(°C)	V (l)	(mm)	(W)	(kg)	(kWh/year)*
YG-05250	-2/+8	282	1360 x 700 x 950	215	102	919
YG-05251	-18/-22	282	1360 x 700 x 950	520	110	2592



SEE ALSO  
shelves and guides

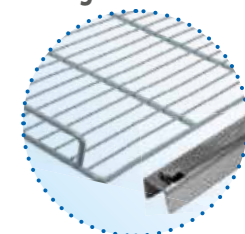

p. 87

#### Cooling and freezing 3-door tables with side compressor – line 700

• 3 coated shelves

YATO	(°C)	V (l)	(mm)	(W)	(kg)	(kWh/year)*
YG-05255	-2/+8	417	1795 x 700 x 950	230	134	1145
YG-05256	-18/-22	417	1795 x 700 x 950	560	159	3103

\* power consumption



### 3-door refrigerated base – line 700

DE Unterbaukühltsch 3-türig – Linie 700  
 RU Холодильный стол 3-дверный – линия 700  
 UK Основа охолодження 3-дверна – лінія 700  
 LT Šaldomas pagrindas su 3 durimis – linija 700  
 LV Aukstuma galds ar 3 durvīm – sērija 700  
 CS Chladicí 3-dvěřová základna – řada 700  
 SK Chladený základ 3-dverový – linka 700  
 HU 3 ajtós hűtőasztal – 700-as sorozat  
 RO Masă frigorifică cu 3 uși – linia 700  
 ES Mesas frigoríficas con tablero de trabajo – serie 700  
 FR Tables de réfrigération avec le plan de travail et à trois portes – série 700  
 PT Base de resfriamento de 3 portas – linha 700  
 IT Base frigorifera a 3 ante – linea 700  
 BG Хладилна основа с 3 врати – линия 700  
 EL 3-θύρη βάση ψύξης – γραμμή 700  
 ZH 三门冷藏柜-700 mm



<b>SS 201</b> STAINLESS STEEL	FORCED AIR CIRCULATION		AUTOMATIC DEFROST
max <b>40kg</b> SHELF	SELF CLOSING DOOR	x4 <b>140-200mm</b> ADJUSTABLE FEET	<b>R290</b> REFRIGERANT



YATO	(°C)	V (l)	(mm)	(W)	(kg)	(kWh/year)*
YG-05259	-2/+8	317	1795 x 700 x 650	230	107	1132

### Freezing cabinet for ice cream cuvettes

DE Gefrierschrank für Eisküvetten  
 RU Морозильный шкаф для кювет с мороженым  
 UK Морозильна камера для ящиків з морозивом  
 LT Šaldymo spintos ledų indams  
 LV Aukstumaskapis saldējuma kastēm  
 CS Mrazicí box na nádoby na led  
 SK Mraziaca skriňa pre nádoby na ľad  
 HU Fagylaltfagyasztó szekrény  
 RO Dulap de congelare pentru cuve de înghețată  
 ES Armarios frigoríficos para la heladería  
 FR Armoires de stockage pour bacs à crème glacée  
 PT Armário de congelamento para bandejas de sorvete  
 IT Congelatore per vaschette per gelati  
 BG Фризер шкаф за сладолед  
 EL Θάλαμος κατάψυξης για δοχεία πάγου  
 ZH 冰淇淋冷藏柜



<b>SS 201</b> STAINLESS STEEL	FORCED AIR CIRCULATION		AUTOMATIC DEFROST	max <b>40kg</b> SHELF	SELF CLOSING DOOR
LOCK	LED LIGHT	x4 <b>140-200mm</b> ADJUSTABLE FEET	<b>R290</b> REFRIGERANT		



YATO	(°C)	V (l)	(mm)	(W)	(kg)	(kWh/rok)*
YG-05230	-18/-22	737	740 x 990 x 2010	520	183	3061

\* power consumption

### Glass cooling cabinet

DE Kühlschrank mit Glastür  
 RU Холодильный шкаф со стеклянными дверцами  
 UK Холодильна шафа зі склом  
 LT Šaldymo spintos su stiklu  
 LV Aukstuma skapis ar stikla durvīm  
 CS Prosklený chladicí box  
 SK Chladená skriňa zasklená  
 HU Üvegezett hűtőszekrény  
 RO Dulap de răcire cu ușă din sticlă  
 ES Armario frigorífico acristalado  
 FR Armoire réfrigérée avec des portes en verre  
 PT Armário de vidro de refrigeração  
 IT Armadio refrigerato vetrato  
 BG Хладилен шкаф, остъклен  
 EL Θάλαμος κατάψυξης με τζάμι  
 ZH 玻璃冷藏柜



<b>SS 201</b> STAINLESS STEEL	FORCED AIR CIRCULATION		AUTOMATIC DEFROST
<b>GN 2/1</b>	max <b>40kg</b> SHELF	SELF CLOSING DOOR	LED LIGHT

LOCK	DOUBLE GLASS	x4 <b>140-200mm</b> ADJUSTABLE FEET	<b>R290</b> REFRIGERANT
------	--------------	--	----------------------------



YATO	(°C)	V (l)	(mm)	(W)	(kg)
YG-05225	+2/+8	650	740 x 830 x 2010	215	132

### Glass cooling tables – line 700

DE Kühltsche mit Glastüren – Linie 700  
 RU Холодильные столы со стеклянными дверцами – линия 700  
 UK Холодильні столи зі склом – лінія 700  
 LT Šaldomi darbastaliai su stiklinimu – linija 700  
 LV Aukstuma galdi ar stikla durvīm – sērija 700  
 CS Prosklené chladicí stoly – řada 700  
 SK Chladené stoly zasklené – linka 700  
 HU Üvegezett hűtőasztalok – 700-as sorozat  
 RO Mesă rece cu ușă din sticlă – linia 700  
 ES Mesas de refrigeración con puertas de cristal – serie 700  
 FR Tables de réfrigération avec portes en verre – série 700  
 PT Mesas de vidro de refrigeração – linha 700  
 IT Armadio refrigerato vetrato – linea 700  
 BG Хладилни маси, остъклени – линия 700  
 EL Τραπεζι ψύξης με τζάμι – γραμμή 700  
 ZH 玻璃冷藏柜 – 700 mm

<b>SS 201</b> STAINLESS STEEL	FORCED AIR CIRCULATION		AUTOMATIC DEFROST	max <b>40kg</b> SHELF
SELF CLOSING DOOR	LED LIGHT	DOUBLE GLASS	x4 <b>140-200mm</b> ADJUSTABLE FEET	<b>R290</b> REFRIGERANT



#### YG-05252 Glass cooling 2-door table – line 700

- 2 coated shelves
- tabletop dimensions: 1360 x 700 mm



YATO	(°C)	V (l)	(mm)	(W)	(kg)
YG-05252	+2/+8	282	1360 x 700 x 850	215	108
YG-05257	+2/+8	417	1795 x 700 x 850	230	134

#### YG-05257 Glass cooling 3-door table – line 700

- 3 coated shelves
- tabletop dimensions: 1795 x 700 mm



### Cooling and freezing cabinets for bakery

DE Kühl- und Gefrierschränke für Backwaren  
 RU Холодильные и морозильные шкафы для пекарен  
 UK Холодильні та морозильні шафи для хлібобулочних виробів  
 LT Kepimo vėsiniimo ir šaldymo spintos  
 LV Maiznieku aukstuma skapji  
 CS Pekařské chladicí a mrazicí boxy  
 SK Pekárske, chladené a mraziace skrine  
 HU Hűtő- és fagyasztószekrény pékségek számára  
 RO Dulapuri de răcire și congelare pentru panificație  
 ES Armarios refrigerados pastelería y panadería  
 FR Armoires réfrigérées pour pâtisserie et boulangerie  
 PT Armários de refrigeração e congelamento para padarias  
 IT Armadi da forno refrigerati  
 BG Хладилни шкафове и фризерни за хлебни изделия  
 EL Θάλαμοι αρτοποιίας ψύξης και κατάψυξης  
 ZH 烘焙冷藏柜

**YG-05226**  
Cooling cabinet

**YG-05227**  
Freezing cabinet

YATO	(°C)	V (l)	(mm)	(W)	(kg)	(kWh/year)*
YG-05226	-2/+8	737	740 x 990 x 2010	295	134	1000
YG-05227	-18/-22	737	740 x 990 x 2010	520	183	3061

### 2-door cooling table for bakery

DE Backwarenkühltisch 2-türig  
 RU Пекарский 2-дверный холодильный стол  
 UK Холодильний стіл для хлібобулочних виробів 2-дверний  
 LT Kepimo šaldomas darbastalis  
 LV Maiznieku aukstuma galds ar 2 durvīm  
 CS Chladicí pekařské 2-dvéřové stoly  
 SK Chladený pekársky stôl 2-dverový  
 HU 2 ajtós hűtőasztal pékségek számára  
 RO Masă rece cu 2 uși pentru brutărie  
 ES Mesas de refrigeración de dos puertas para pastelería y panadería  
 FR Tables de réfrigération à deux portes pour pâtisserie et boulangerie  
 PT Mesa de refrigeração para padarias 2 portas  
 IT Tavolo refrigerato da forno con 2 ante  
 BG Хладилна маса за хлебни изделия с 2 врати  
 EL Τραπέζι ψύξης αρτοποιίας 2-θυρών  
 ZH 烘焙两门冷藏台

YATO	(°C)	V (l)	(mm)	(W)	(kg)	(kWh/year)*
YG-05254	-2/+8	390	1510 x 800 x 845	215	110	1026

\* power consumption



- SS 201 STAINLESS STEEL
- FORCED AIR CIRCULATION
- AUTOMATIC DEFROST
- x10 ADJUSTABLE LEVELS
- max 40kg SHELF
- SELF CLOSING DOOR
- LOCK
- LED LIGHT
- x4 140-200mm ADJUSTABLE FEET
- R290 REFRIGERANT



### Salad cooling tables

DE Saladetten  
 RU Холодильные столы для салата  
 UK Холодильні столи для салатів  
 LT Šaldomi darbastaliai salotoms  
 LV Aukstuma galsi salātiem  
 CS Chladicí salátové stoly  
 SK Chladené stoly pre šalát  
 HU Saláta hűtőasztalok  
 RO Masă rece pentru salate

ES Mesas de refrigeración para ensaladas  
 FR Tables réfrigérées préparation de salades  
 PT Mesas de refrigeração de salada  
 IT Tavolo refrigerato per insalate  
 BG Хладилни маси за салати  
 EL Τραπέζια ψύξης σαλατών  
 ZH 色拉冷藏台

### Cooling 2-door table with a glass extension

- 2 coated shelves
- top hole for containers GN (4 x GN 1/2 and 3 x GN 1/6)
- tempered glass extension

**R600a**  
REFRIGERANT

### Cooling 2-door table with a cover

- 2 coated shelves
- top hole for containers GN (4 x GN 1/2 and 3 x GN 1/6)
- swing top cover

**R600a**  
REFRIGERANT



YATO	(°C)	V (l)	(mm)	(W)	(kg)
YG-05260	+2/+8	240	900 x 700 x 850	170	76

YATO	(°C)	V (l)	(mm)	(W)	(kg)
YG-05262	+2/+8	240	900 x 700 x 876	170	70

### Cooling 3-door table with a cover

- 3 coated shelves
- top hole for containers GN (4 x GN 1/1)
- swing top cover

**R290**  
REFRIGERANT



YATO	(°C)	V (l)	(mm)	(W)	(kg)
YG-05290	+2/+8	368	1365 x 700 x 876	240	115

**SEE ALSO**  
GN containers

### Pizza cooling tables

DE Pizzakühlische  
RU Холодильные столы для пиццы  
UK Холодильні столи для піци  
LT Šaldomi darbastaliai picoms  
LV Aukstuma galdi picai  
CS Chladicí stoly na pizzu  
SK Cladené stoly pre pizzu  
HU Pizza hűtőasztalok

RO Masă rece pentru pizza  
ES Mesas de refrigeración para pizzas  
FR Tables réfrigérées pour pizza  
PT Mesas de refrigeração de pizza  
IT Tavolo refrigerato per pizza  
BG Хладилни маси за пицца  
EL Τραπεζία ψύξης πίτσας  
ZH 披萨冷藏台

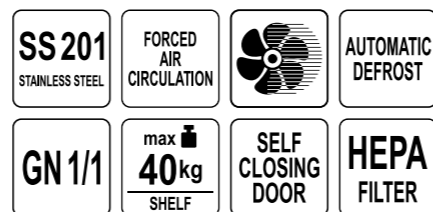

#### Cooling 2-door table with extension and granite top

- lower compressor – Zanussi
- cooling agent: R600a
- marble work top
- 2 coated shelves with dimensions of 325 x 560 mm
- top hole for GN containers (5 x GN 1/6)

**R600a**  
REFRIGERANT

YATO	(°C)	V (l)	(mm)	(W)	(kg)
YG-05275	+2/+8	240	900 x 700 x 1075	170	105

#### Pizza cooling 3-door table with extension and granite top

- compressors – Embraco (table) and Zanussi (extension)
- cooling agent: R290 (table), R600a (extension)
- granite work top
- 3 coated shelves with dimensions of 325 x 560 mm
- extension for GN containers (6 x GN 1/4)

**R290**  
REFRIGERANT

**R600a**  
REFRIGERANT

YATO	(°C)	V (l)	(mm)	(W)	(kg)
YG-05305	+2/+8	368	1400 x 700 x 1020 + 1400 x 335 x 435	240 + 110	170 + 27

#### Pizza cooling 2-door table with 7 drawers and granite top

- side compressor – Embraco
- cooling agent: R290
- granite work top
- 2 coated shelves with dimensions of 408 x 630 mm
- 7 shelves without cooling
- 6 steering wheels, including 3 wheels with brakes

**R290**  
REFRIGERANT

YATO	(°C)	V (l)	(mm)	(W)	(kg)
YG-05310	-2/+8	580	2025 x 800 x 1000	215	332

### Accessories for cooling cabinets and tables

DE Zubehör für Kühlschränke und -Tische  
RU Аксессуары для холодильных шкафов и столов  
UK Аксесуари для шаф і холодильних столів  
LT Šaldomų spintų ir darbastalių priedai  
LV Aukstuma skapju un galdu piederumi  
CS Příslušenství pro chladicí boxy a stoly  
SK Wybavenie pre chladené skrine a stoly  
HU Kiegészítők hűtőszekrényekhez és hűtőasztalokhoz

RO Accesorii pentru dulapuri frigorifice și mese reci  
ES Accesorios para armarios y mesas de refrigeración  
FR Accessoires pour armoires et tables de réfrigération  
PT Acessórios para armários e mesas de refrigeração  
IT Accessori per armadi e tavoli refrigerati  
BG Аксесоари за хладилни маси и шкафове  
EL Αξεσουάρ για θαλάμους και τραπέζια ψύξης  
ZH 冷藏柜冷藏台配件

#### Coated shelves



**PVC**  
COATED SHELVES

YATO	(mm)	FOR:
YG-05400	534 x 650	YG-05200, YG-05201, YG-05210, YG-05211, YG-05225

YATO	(mm)	FOR:
YG-05403	534 x 650	YG-05215, YG-05216, YG-05220, YG-05221



YATO	(mm)	FOR:
YG-05406	333 x 530	YG-05250, YG-05251, YG-05252, YG-05255, YG-05256, YG-05257, YG-05259, YG-05270, YG-05300
YG-05409	325 x 560	YG-05260, YG-05262, YG-05275, YG-05290, YG-05305
YG-05412	408 x 630	YG-05310, YG-05254
YG-05420	333 x 430	YG-05253, YG-05258

#### Shelf guides



YATO	L/R*	FOR:
YG-05401	L	YG-05200, YG-05201, YG-05210, YG-05211, YG-05225
YG-05402	R	YG-05200, YG-05201, YG-05210, YG-05211, YG-05225
YG-05404	L	YG-05215, YG-05216, YG-05220, YG-05221
YG-05405	R	YG-05215, YG-05216, YG-05220, YG-05221
YG-05407	L	YG-05250, YG-05251, YG-05252, YG-05255, YG-05256, YG-05257, YG-05259, YG-05270, YG-05300
YG-05408	R	YG-05250, YG-05251, YG-05252, YG-05255, YG-05256, YG-05257, YG-05259, YG-05270, YG-05300
YG-05410	L	YG-05260, YG-05262, YG-05275, YG-05290, YG-05305
YG-05411	R	YG-05260, YG-05262, YG-05275, YG-05290, YG-05305
YG-05413	L	YG-05310, YG-05254
YG-05414	R	YG-05310, YG-05254
YG-05421	L	YG-05253, YG-05258
YG-05422	R	YG-05253, YG-05258

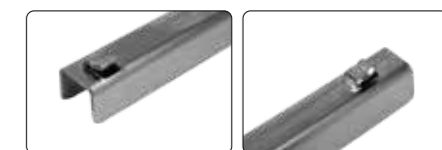

YATO	L/R*	FOR:
YG-05423	L	YG-05226
YG-05424	R	YG-05226
YG-05425	L	YG-05227
YG-05426	R	YG-05227



\* L – left, R – right

### Cooling extensions

- DE Kühlauflätze
- RU Холодильные витрины
- UK Холодильні надставки
- LT Aušinimo pratėsimai
- LV Aukstuma uzliktņi
- CS Chladicí nástavky
- SK Chladiaci nadstavce
- HU Hűtő feltétek
- RO Extensii pentru mese reci
- ES Vitrinas expositoras de comida fría
- FR Vitrines réfrigérées pour aliments
- PT Extensões de refrigeração
- IT Unità di refrigerazione
- BG Хладилно надграждане
- EL Ψυγείο μπουφέ
- ZH 其他冷藏设备



- SS 201**  
STAINLESS STEEL
- AUTOMATIC DEFROST**
- DIGITAL TEMPERATURE CONTROLLER**
- HARDENED GLASS**
- R600a**  
REFRIGERANT
- HEPA FILTER**



**SEE ALSO**  
GN containers



p. 7

YATO	(°C)		(mm)	(W)	(kg)
YG-05320	+2/+8	5 x GN 1/4	1200 x 335 x 435	110	25
YG-05321	+2/+8	6 x GN 1/4	1400 x 335 x 435	110	27
YG-05322	+2/+8	7 x GN 1/4	1500 x 335 x 435	110	29
YG-05323	+2/+8	8 x GN 1/4	1800 x 335 x 435	110	32
YG-05330	+2/+8	6 x GN 1/3	1400 x 395 x 435	110	30
YG-05331	+2/+8	7 x GN 1/3	1600 x 395 x 435	110	32
YG-05332	+2/+8	9 x GN 1/3	2000 x 395 x 435	110	36

### Refrigerated display cases for sushi

- DE Sushi und Tapas Belegstation
- RU Холодильные витрины для суши
- UK Холодильні вітрини для суши
- LT Sušių šaldymo vitrina
- LV Aukstuma vitrinas suši
- CS Chladicí pulty na sushi
- SK Chladené výklady pre sushi
- HU Sushi hűtővitrin
- RO Vitrină frigorifică pentru sushi
- ES Vitrinas expositoras de sushi
- FR Vitrines réfrigérées pour sushi
- PT Vitrinas de refrigeração de sushi
- IT Vetrine refrigerate per sushi
- BG Хладилни витрини за суши
- EL Βιτρίνα ψύξης σουσί
- ZH 寿司冷藏展示柜



- AUTOMATIC DEFROST**
- DIGITAL TEMPERATURE CONTROLLER**
- LED LIGHT**
- R600a**  
REFRIGERANT



• panoramic, rounded front glass

YATO	(°C)		(mm)	(W)	(kg)
YG-05000	0/+6	4 x GN 1/3	1177 x 420 x 295	125	34.5
YG-05001	0/+6	5 x GN 1/3	1350 x 420 x 295	135	38.5
YG-05002	0/+6	6 x GN 1/3	1530 x 420 x 295	145	41.5
YG-05005	0/+6	5 x GN 1/2	1800 x 420 x 295	160	45



• glass shelf

YATO	(°C)		(mm)	(W)	(kg)
YG-05007	0/+6	5 x GN 1/2	1755 x 395 x 375	180	53

### Refrigerated display cases for bottles

- DE Kühlvitrinen für Flaschen
- RU Холодильные витрины для бутылок
- UK Холодильні вітрини для пляшок
- LT Butelių šaldymo vitrina
- LV Aukstuma vitrinas pudelēm
- CS Chladicí pulty na láhve
- SK Chladené výklady pre fľaše
- HU Üveg hűtővitrin
- RO Dulap frigorific pentru băuturi
- ES Vitrinas refrigeradas para botellas
- FR Vitrines réfrigérées pour bouteilles
- PT Vitrinas de refrigeração para garrafas
- IT Vetrine refrigerate per bottiglie
- BG Хладилни витрини за бутилки
- EL Βιτρίνες ψύξης μπουκαλιών
- ZH 冷藏展示柜



#### 1-door case

• 2 chrome plated shelves  
with dimensions of 515 x 350 mm



YATO	(°C)	V (l)	(mm)	(W)	(kg)
YG-05350	+2/+8	142	600 x 515 x 905	180	83

#### 2-door case

• 4 chrome plated shelves  
with dimensions of 835 x 350 mm



YATO	(°C)	V (l)	(mm)	(W)	(kg)
YG-05355	+2/+8	227	920 x 515 x 905	200	102

#### 2-door case (sliding doors)

• 4 chrome plated shelves  
with dimensions of 835 x 350 mm



YATO	(°C)	V (l)	(mm)	(W)	(kg)
YG-05356	+2/+8	227	920 x 515 x 905	200	102

#### 3-door case

• 6 chrome plated shelves:  
middle with dimensions  
445 x 350 mm  
and side 400 x 350 mm



YATO	(°C)	V (l)	(mm)	(W)	(kg)
YG-05360	+2/+8	341	1350 x 515 x 910	225	130

- SS AI**
- FORCED AIR CIRCULATION**
- LED LIGHT**
- LOCK**
- SELF CLOSING DOOR**
- HARDENED GLASS**
- CHROME PLATED SHELVES**
- R600a**  
REFRIGERANT
- HEPA FILTER**

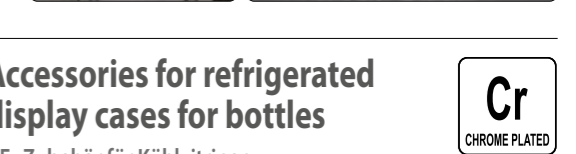

### Accessories for refrigerated display cases for bottles



DE Zubehör für Kühlvitrinen für Flaschen

- RU Аксессуары для холодильных витрин для бутылок
- UK Аксесуари для холодильних установок для пляшок
- LT Butelių šaldymo vitrinų priedai
- LV Aukstuma vitrinu pudelēm piederumi
- CS Příslušenství k chladicím pultům na láhve
- SK Výbavenie pre chladené výklady pre fľaše
- HU Kiegészítők üveg hűtővitrinekhez
- RO Accesorii pentru dulapuri frigorifice pentru băuturi
- ES Accesorios para vitrinas refrigeradas para botellas
- FR Accessoires pour vitrines réfrigérées pour bouteilles
- PT Acessórios para vitrinas de refrigeração para garrafas
- IT Accessori per vetrine refrigerate per bottiglie
- BG Аксесоари за хладилни витрини за бутилки
- EL Αξεσουάρ για βιτρίνες ψύξης μπουκαλιών
- ZH 冷藏展示柜配件

#### Chrome plated shelves

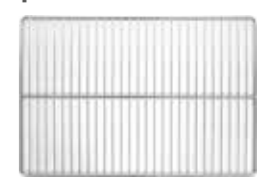

YATO	(mm)	FOR:
YG-05415	515 x 350	YG-05350

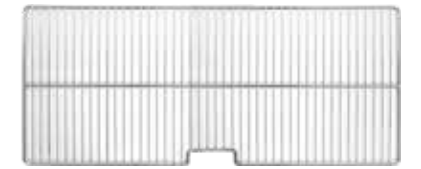

YATO	(mm)	FOR:
YG-05416	835 x 350	YG-05355, YG-05356

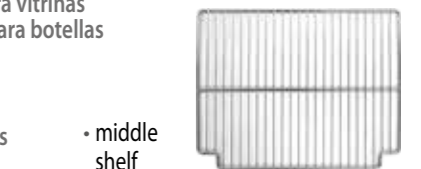

YATO	(mm)	FOR:
YG-05417	445 x 350	YG-05360

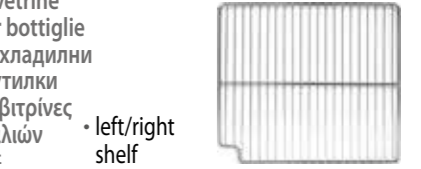

YATO	(mm)	FOR:
YG-05418	400 x 350	YG-05360

#### K-type shelf holder



YATO	(mm)	FOR:
YG-05419	400 x 350	YG-05350, YG-05355, YG-05356, YG-05360

### Refrigerated display cases

- DE Kühlvitriren
- RU Холодильные витрины
- UK Холодильні вітрини
- LT Šaldymo vitrinos
- LV Aukstuma vitrinas
- CS Chladicí pulty
- SK Chladené výklady
- HU Hűtővitrinek
- RO Vitrine frigorifice
- ES Vitrinas refrigeradas
- FR Vitrines réfrigérées
- PT Vitrinas de refrigeração
- IT Vetrine refrigerate
- BG Хладилни витрини
- EL Βιτρίνες ψύξης
- ZH 冷藏展示柜



- AUTOMATIC DEFROST
- DIGITAL TEMPERATURE CONTROLLER
- LED LIGHT
- R600a REFRIGERANT
- ADJUSTABLE SHELVES



A B

YATO	(°C)	V (l)	(mm)	(W)	COLOUR	(kg)
YG-05020	0/+12	100	682 x 450 x 675	160	●	39.1
YG-05021	0/+12	100	682 x 450 x 675	160	○	39.1
YG-05022	0/+12	100	682 x 450 x 675	160	○	39.1



A B

YATO	(°C)	V (l)	(mm)	(W)	(kg)
YG-05025	0/+12	120	688 x 568 x 686	160	64



### Refrigerated display cases

- DE Kühlvitriren
- RO Vitrine frigorifice
- RU Холодильные витрины
- ES Vitrinas refrigeradas
- UK Холодильні вітрини
- FR Vitrines réfrigérées
- LT Šaldymo vitrinos
- PT Vitrinas de refrigeração
- LV Aukstuma vitrinas
- IT Vetrine refrigerate
- CS Chladicí pulty
- BG Хладилни витрини
- SK Chladené výklady
- EL Βιτρίνες ψύξης
- ZH 冷藏展示柜

- AUTOMATIC DEFROST
- DIGITAL TEMPERATURE CONTROLLER
- LED LIGHT
- ADJUSTABLE SHELVES

- 4 SIDE DOUBLE GLASS
- R290 REFRIGERANT
- 360° 4x



A C

YATO	(°C)	V (l)	(mm)	(W)	(kg)
YG-05040	+2/+8	300	650 x 805 x 1445	450	135
YG-05045	+2/+8	400	900 x 805 x 1445	450	160



### Refrigerated display cases

- DE Kühlvitriren
- RU Холодильные витрины
- UK Холодильні вітрини
- LT Šaldymo vitrinos
- LV Aukstuma vitrinas
- CS Chladicí pulty
- SK Chladené výklady
- HU Hűtővitrinek
- RO Vitrine frigorifice
- ES Vitrinas refrigeradas
- FR Vitrines réfrigérées
- PT Vitrinas de refrigeração
- IT Vetrine refrigerate
- BG Хладилни витрини
- EL Βιτρίνες ψύξης
- ZH 冷藏展示柜



- AUTOMATIC DEFROST
- DIGITAL TEMPERATURE CONTROLLER
- LED LIGHT
- 4 SIDE DOUBLE GLASS
- ADJUSTABLE SHELVES
- R600a REFRIGERANT

A G C

YATO	(°C)	V (l)	(mm)	(W)	COLOUR	(kg)
YG-05055	0/+6	78	428 x 386 x 960	164	○	33.8
YG-05056	0/+6	78	428 x 386 x 960	164	●	33.8
YG-05057	0/+6	78	428 x 386 x 960	164	○	33.8

### Refrigerated display case

- DE Kühlvitrine
- RU Холодильная витрина
- UK Холодильна вітрина
- LT Šaldymo vitrina
- LV Aukstuma vitrina
- CS Chladicí pult
- SK Chladený výklad
- HU Hűtővitrin
- RO Vitrine frigorifice
- ES Vitrina refrigerada
- FR Vitrine réfrigérée
- PT Vitrina de refrigeração
- IT Vetrina refrigerata
- BG Хладилна витрина
- EL Βιτρίνα ψύξης
- ZH 冷藏展示柜



- AUTOMATIC DEFROST
- DIGITAL TEMPERATURE CONTROLLER
- LED LIGHT
- 4 SIDE DOUBLE GLASS
- ADJUSTABLE SHELVES
- R600a REFRIGERANT

A G C

YATO	(°C)	V (l)	(mm)	(W)	(kg)
YG-05060	0/+6	78	430 x 390 x 986	180	42

### Refrigerated display cases

- DE Kühlvitriren
- RU Холодильные витрины
- UK Холодильні вітрини
- LT Šaldymo vitrinos
- LV Aukstuma vitrinas
- CS Chladicí pulty
- SK Chladené výklady
- HU Hűtővitrinek
- RO Vitrine frigorifice
- ES Vitrinas refrigeradas
- FR Vitrines réfrigérées
- PT Vitrinas de refrigeração
- IT Vetrine refrigerate
- BG Хладилни витрини
- EL Βιτρίνες ψύξης
- ZH 冷藏展示柜



- AUTOMATIC DEFROST
- DIGITAL TEMPERATURE CONTROLLER
- LED LIGHT
- 4 SIDE DOUBLE GLASS
- ADJUSTABLE SHELVES
- R290 REFRIGERANT
- 360° 4x

A G C

YATO	(°C)	V (l)	(mm)	(W)	(kg)
YG-05064	0/+6	270	650 x 650 x 1500	636	140
YG-05068	0/+6	400	650 x 650 x 1908	636	175

### Refrigerated display case

- DE Kühlvitrine
- RU Холодильная витрина
- UK Холодильна вітрина
- LT Šaldymo vitrina
- LV Aukstuma vitrina
- CS Chladicí pult
- SK Chladený výklad
- HU Hűtővitrin
- RO Vitrine frigorifice
- ES Vitrina refrigerada
- FR Vitrine réfrigérée
- PT Vitrina de refrigeração
- IT Vetrina refrigerata
- BG Хладилна витрина
- EL Βιτρίνα ψύξης
- ZH 冷藏展示柜



- AUTOMATIC DEFROST
- DIGITAL TEMPERATURE CONTROLLER
- LED LIGHT
- ROUND DOUBLE GLASS
- ROTATED CHROME PLATED SHELVES
- R600a REFRIGERANT

A G C

YATO	(°C)	V (l)	(mm)	(W)	(kg)
YG-05090	+2/+12	73	504 x 504 x 1060	170	45



### Refrigerated display cases

- DE Kühlvitrienen
- RU Холодильные витрины
- UK Холодильні вітрини
- LT Šaldymo vitrinos
- LV Aukstuma vitrinas
- CS Chladicí pulty
- SK Chladené výklady
- HU Hűtővitrinek
- RO Vitrine frigorifice
- ES Vitrinas refrigeradas
- FR Vitrines réfrigérées
- PT Vitrinas de refrigeração
- IT Vetrine refrigerate
- BG Хладилни витрини
- EL Βιτρίνες ψύξης
- ZH 冷藏展示柜



- cooling agent: R600a
- 3 adjustable glass shelves with diameter of 390 mm

YATO	(°C)	V (l)	(mm)	(W)	(kg)
YG-05094	+2/+8	100	480 x 480 x 1030	170	50



- cooling agent: R290
- 4 adjustable glass shelves with diameter of 540 mm

YATO	(°C)	V (l)	(mm)	(W)	(kg)
YG-05098	+2/+8	400	680 x 680 x 1750	450	127

- FORCED AIR CIRCULATION
- AUTOMATIC DEFROST
- DIGITAL TEMPERATURE CONTROLLER
- LED LIGHT
- ROUND DOUBLE GLASS
- AUTOMATIC DOOR CLOSER
- ADJUSTABLE GLASS SHELVES



**R290**  
REFRIGERANT

**360°**  
**4x**



### Sink with knee switch

- DE Knie-Kontakt-Handwaschbecken
- RU Рукомойник с коленным приводом
- UK Колінна раковина
- LT Bekontaktė virtuvinė plautuvė
- LV Ceļgalu izlietne
- CS Kolenní umyvadlo
- SK Kolenné umývadlo
- HU Kézmosó
- RO Chiuvetă cu acționare la genunchi
- ES Lavamanos rodilla
- FR Lavabo à commande au genou
- PT Pia com acionamento por joelho
- IT Lavabo con comando a ginocchio
- BG Безконтактна мивка с бутон за коляно
- EL Υγειονομικός νιπτήρας με πλάτη
- ZH 不锈钢洗涤槽



- SS 304/201  
STAINLESS STEEL
- 40mm  
DRAIN HOLE
- TEMPERATURE REGULATION
- WATER STOP VALVE



YATO	(mm)
YG-10010	400 x 330 x 570

### Automatic water softener with bypass

- DE Automatischer Wasserenthärter mit Bypass
- RU Автоматический смягчитель воды с байпасом
- UK Автоматичний пом'якшувач води з байпасом
- LT Automatinis vandens minkštintuvas su apėjimu
- LV Automātiskais ūdens mīkstinātājs ar apeju
- CS Automatický změkčovač vody z bypasse
- SK Automatický prístroj na zmäkčenie vody s bypassom
- HU Automatikus vízlágyító bypass-szal
- RO Aparat de dedurizare a apei cu bypass
- ES Descalcificador automático con bypass
- FR Adoucisseur d'eau automatique, jeu de clés Bypass inclus
- PT Abrandador de água automático com bypass
- IT Addolcitore automatico d'acqua con bypass
- BG Автоматичен омекотител за вода с байпас
- EL Αυτόματο μαλακτικό νερού με bypass
- ZH 软水机



- 500l/h
- 5L  
CAPACITY
- 5-38°C  
WATER TEMPERATURE
- 0.1-0.6  
MPa  
WORKING PRESSURE
- PE
- 3/4"  
CONNECTION
- BYPASS VALVE
- 15kg  
SALT TANK CAPACITY



YATO	(l/h)	(MPa)	(mm)	(kg)
YG-09510	500	0.1-0.6	510 x 520 x 215	9



TOYA S.A.

ul. Sołtysowicka 13-15  
51-168 Wrocław  
☎ (+48 71) 32 46 200  
fax: (+48 71) 32 46 370  
sales@yato.pl (domestic)  
export@yato.pl (export)  
import@yato.pl (import)

WARSAW BRANCH

Teren ProLogis Park Nadarzyn  
al. Kasztanowa 160  
05-831 Młochów k. Warszawy  
☎ (+48 22) 73 82 800  
☎ (+48 22) 73 82 828  
sales@yato.pl (domestic)  
export@yato.pl (export)

TOYA ROMANIA S.A.

Soseaua Stefanesti 8-8a  
077175 Stefanestii De Jos  
☎ (+40 031) 710 8692  
office@yato.ro

YATO TOOLS (SHANGHAI) Co., Ltd.

YATO TOOLS (JIAXING) Co., Ltd.  
No. 1, Lane 1300  
East Kangqiao Road  
Shanghai, China 201315  
☎ (+86 21) 681 829 50  
fax: (+86 21) 681 829 51  
yato@yato-sh.com



V2.22

YOUR TRUSTED SUPPLIER

yatogastro.com