

SK 104 - Double Swing

The installation should be formed by connecting a total of 4 bearing clamps with chains, 2 for each swing, to a 300 cm-long Ø114 mm minimum 2.5 mm pipe connected by pipes with a minimum wall thickness of Ø 114 mm and 2.5 mm pipes that pass into each other on both sides. The distance between the bottom surface of the swing seat and the Decking surface should be at least 40cm (+/-10cm). The connecting chains will be used as hot-dipped galvanized, with a minimum of 25 microns against rust. 6 mm caliber and double row chain should be used to prevent finger jamming. Polyethylene accessories that conceal the detail can be used optionally in the swing struts combinations.

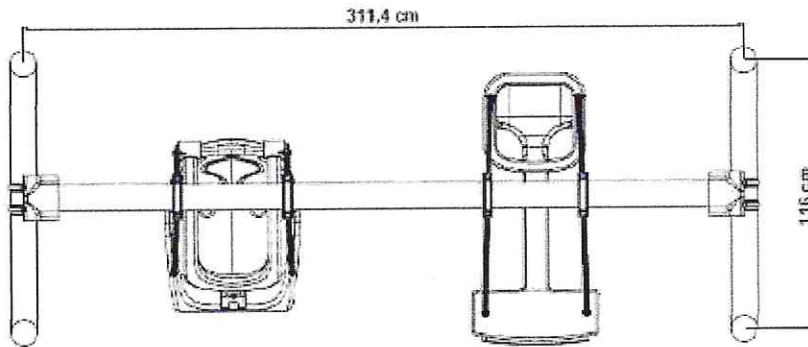

- The mother's lap swing seat should be closed on the 4 side of the child's seat, and the seat where the mother will sit should be produced in such a way that there are fine lines to prevent slipping. Reclining Seats should be single. A Shock-absorbing rubber bumper should be used on the front surface of the swing seat to prevent collisions. The swing seat width and length should be manufactured to be 116.5x55 cm with a minimum height of 36 cm. The width of the seating area where the child will sit is min. it should be 33 cm, a Mother's lap swing seat should weigh at least 10 kg.

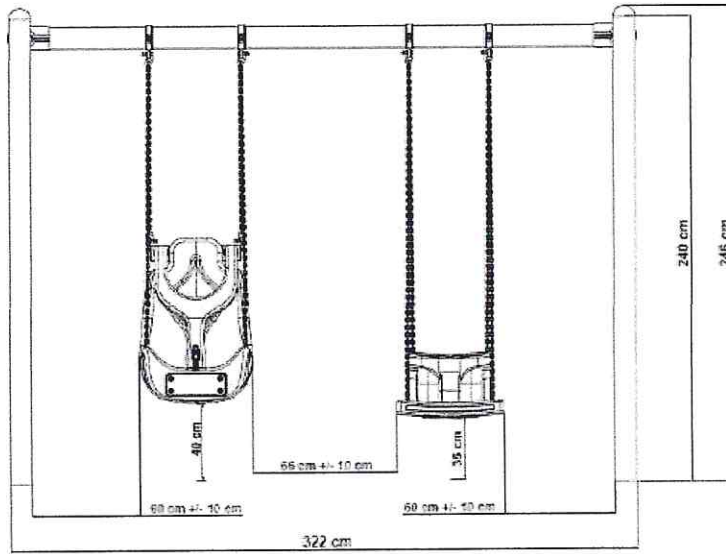
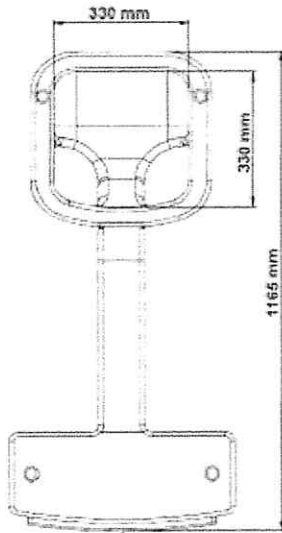
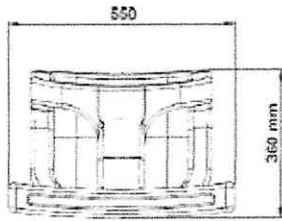

- The swing seat should consist of polyethylene material with a front protection belt for 3-side closed safety. Reclining seats should be single person, there should be a protection belt with a mother and child figure. The unobstructed swing seat should be manufactured in such a way that its width and length are 59x71 cm and its height is at least 87.5 cm. The width of the seating area should be at least 50 cm, the bracket must weigh a minimum of 10 kg along with the swing railing. A Shock-absorbing rubber bumper should be provided against bumps in the front part of the unobstructed seat.

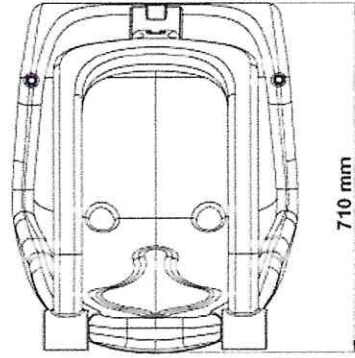
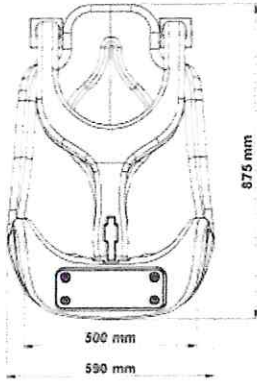

İSİLTİ ÇOCUK OYUN GRUPLARI PLASTİK SAN. TİC. A.Ş.
Büyükkayarıkışb. Mh. 416 Nolu Sk. No:1 Selçuklu/KONYA
Tel: +90 332 602 10 70 E-mail: bilgi@isiltiplastik.com
Selçuk V.D. 468 058 7183 Ticaret Sicil No: 72098

CHAIN SWING SEAT

- The swing seat must be enclosed on three sides and have a front safety belt for protection.
- The chains must be 6 mm caliber, dip-galvanized. The swing seat and chains must comply with TSE safety standards.
- The swing seat and railing must be made of self-colored polyethylene material, double-walled.
- The seats must be single-person and have an animal-shaped safety belt.
- The swing seat must be manufactured with dimensions of 48.5x42 cm in width and length, and a minimum height of 32.5 cm.
- The seating area width must be a minimum of 35 cm.
- The swing seat must have impact-absorbing rubber on the front for safety against impacts.
- The swing, including the railing, must weigh a minimum of 3.5 kg.
- The term "POLYETHYLENE" must be present as per TS EN 1176-2 / 04.02.2010.
- The dyes used for coloring must comply with child health and food regulations.

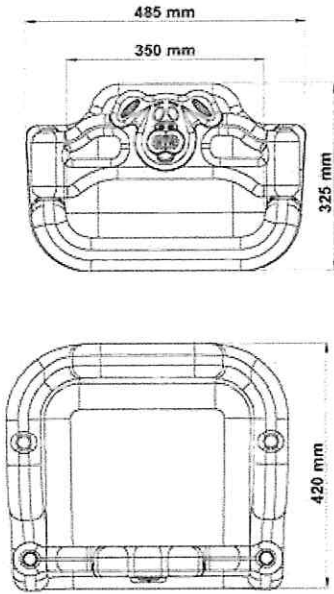

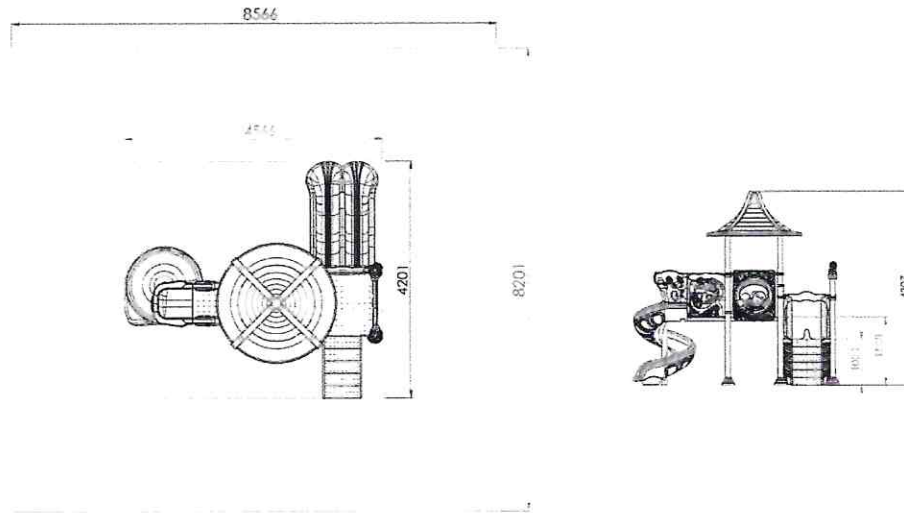

IP-301 TECHNICAL SPECIFICATIONS

- The supporting pipes will be made of metal material with a minimum diameter of 114mm and a wall thickness of 2.5mm.
- The roof, panels, and slides are made of polyethylene material.
- The platform and stairs are made of 2mm sheet metal coated with PVC plastisol.
- The metals in the product are sandblasted and painted with electrostatic powder paint.
- The product does not have any sharp edges or surfaces that could harm the user.
- The screws on the product are covered with screw and bearing concealments.
- The product is manufactured in accordance with EN1176 standards.



TS EN ISO 9001 : KALİTE YÖNETİM SİSTEMİ BELGESİ
TS EN ISO 9001 : QUALITY MANAGEMENT SYSTEM CERTIFICATE

Belge Sahibinin Ünvanı
Name of the certificate holder

: İŞİLTİ ÇOCUK OYUN GRUPLARI PLASTİK SANAYİ TİCARET A.Ş.

Belge Sahibinin Adresi
Address of the certificate holder

: BÜYÜKKAYACIK OSB MH. 416 NOLU SK. NO:1 SELÇUKLU/KONYA

Yönetim Sistemi Standardı
Management System Standard

: TS EN ISO 9001:2015 KALİTE YÖNETİM SİSTEMİ

Belge Kapsamı
Certificate Scope

: ÇOCUK OYUN GRUPLARI VE YEDEK PARÇALARI, PARK VE BAHÇELERDE KULLANILAN BANK, MASA, TABURE, SANDALYE,
KOLTUK VB. MOBİLYALARIN İMALATI (PLASTİK OLANLAR HARİÇ), DIŞ MEKAN SPOR ALETLERİ ÜRETİM VE SATIŞI

EA

Sertifika No
Certificate Number

: KYS5226090500

İlk Belgelendirme Tarihi
First Certification Date

: 28.04.2026

Belge Yenileme Tarihi
Re-certification Date

: 27.04.2029

Belge Geçerlilik Süresi
This certificate is valid until

: 27.04.2027

Bu sertifika, belge sahibinin yönetim sisteminin yukarıda belirtilen yönetim sistemi standartına uygunluğunu belgelendirmek amacıyla, yukarıca tanımlanan faaliyetleri kapsamında verilmiştir.
EuroGap Uluslararası Standart Sertifikasyon Enstitüsü Limited Şirketi tarafından hazırlanmış ve onaylanmıştır.

This certificate has been issued within the scope of the activities described above in order to certify the compliance of the certificate holder's management system with the management system standard mentioned above. Prepared and approved by EuroGap International Standard Certification Institute Limited Company.



TURKAK BDS NO
YS-36DB-B517

FR 53 08 Rev No 01 - 21.12.2023

EuroGap Uluslararası Standart Sertifikasyon Enstitüsü Limited Şirketi / EuroGap Certification and Private Training Services Co. Ltd.
Merkezi/Center : Topraktesik Mah. Topraktesik 2. Sok. No:7 D/110 İç Kapı No: 10 B.İ.Ş.İ.Ş. / TÜRKİYE
Telefon/Phone : +90 412 228 21 52-54 Faks/Fax : +90 412 228 21 53 Web : www.eurogap.com.tr E-mail : info@eurogap.com.tr
İstanbul/Contact : Sırayah Mah. Etiler Lara Sahil Yolu 150/5/ Sk. Turkuaz Apt. No:7 D:2 Muratpaşa-Lara/Atulya/TÜRKİYE
Telefon/Phone : +90 212 316 44 08 Faks/Fax : +90 212 316 44 09 Web : www.eurogap.com.tr E-mail : info@eurogap.com.tr
Sertifika'nın geçerliliğini www.eurogap.com.tr adresinden doğrulayabilirsiniz. You can verify the certificate on our webpage: www.eurogap.com.tr



İŞİLTİ ÇOCUK OYUN GRUPLARI PLASTİK SAN. TİC. A.Ş.
Büyükkayacık Mah. 416 Nolu Sk. No:1 Selçuklu/KONYA
Tel: +90 332 502 70 79 E-mail: bilgi@isiltiplastik.com
Sicil No: 488 658 7183 Ticaret Sicil No: 72098





TS EN ISO 14001 : ÇEVRE YÖNETİM SİSTEMLERİ BELGESİ
TS EN ISO 14001 : ENVIRONMENTAL MANAGEMENT SYSTEMS CERTIFICATE

Firma Adı
Company Name

: İŞİLTİ ÇOCUK OYUN GRUPLARI PLASTİK SANAYİ TİCARET A.Ş.

Firma Adresi
Company Address

: BÜYÜKKAVAYCIK OSB MH. 416 NOLU SK. NO:1 SELÇUKLU/KONYA -TÜRKİYE

Belge Kapsamı
Certificate Scope

ÇOCUK OYUN GRUPLARI VE YEDEK PARÇALARI, PARK VE BAHÇELERDE KULLANILAN BANK, MASA, TABURE,
SANDALYE, KOLTUK, VB. MOBİLYALARIN İMALATI (PLASTİK OLANLAR HARIÇ), DIŞ MEKAN SPOR ALETLERİ
ÜRETİM VE SATIŞI

Sertifika No
Certificate Number

: ÇYS522604140

İlk Belgelendirme
First Certification

: 23.04.2026

1. Gözetim Tarihi
1. Custody Date

: 28.04.2027

2. Gözetim Tarihi
2. Custody Date

: 28.04.2028

Belge Süresi
Certification Duration

: 3 YIL

Belge Bitiş Süresi
Certification Ends Duration

: 28.04.2027

Revizyon No/Tarih
Revision Number/ Date

: 00 / --

Bu sertifika, TS EN ISO 14001:2015 Çevre Yönetim Sistemi Standartı'na uygunluğunu belgelemek amacıyla, yukarıda tanımlanan faaliyetleri kapsamında verilmiştir.
EUROGAP ULUSLARARASI STANDART SERTİFİKASYON ENSTİTÜSÜ LIMITED ŞİRKETİ tarafından hazırlanmış ve onaylanmıştır.

This Certificate has prepared and approved by EUROGAP INTERNATIONAL STANDARDS CERTIFICATION INSTITUTE CO LTD.

EUROGAP ULUSLARARASI STANDART SERTİFİKASYON ENSTİTÜSÜ LIMITED ŞİRKETİ / EUROGAP INTERNATIONAL STANDARD CERTIFICATION INSTITUTE CO LTD.

Şirket/Center : Tepecikler Mah. Toprakçay 2. Blok. No:7 171016 Konya No. 10 Başlıca Büyükbahar / TÜRKİYE

Telefon/Phone : +90 332 220 21 52 54 Faks/Fax : +90 332 220 21 53 Web : www.eurogap.com.tr E-mail : info@eurogap.com.tr

İrtilik/Contact : Şirinkap Mah. Ekin Lari 5. Blok Yürü 1005/50. Tepecikler A.Ş. No:7 B2 Hicriyapa Lari/Amasya/TÜRKİYE

Telefon/Phone : +90 332 216 44 08 Faks/Fax : +90 332 216 44 09 Web : www.eurogap.com.tr E-mail : info@eurogap.com.tr

* Bu sertifika, müşterinin EuroGap tarafından hazırlanmış olan belgelendirme kurallarına ve şartlarına tamamen uygundur ve geçerlidir.

* This certificate is valid as long as the customer acts in accordance with Certificate Rules and Contract Conditions prepared by EuroGap.

You can verify this certificate on our web page : www.eurogap.com.tr

FR056-Rev. No 04-21.12.2023



İŞİLTİ ÇOCUK OYUN GRUPLARI PLASTİK SAN. TİC. A.Ş.
Büyükkavaycık OSB Mah. No:1 Selçuklu/KONYA
Tel: +90 332 220 21 52 E-mail: bilgi@isiltiplastik.com
Selçuk V.D. 468 058 7183 Ticaret Sicil No: 72098



CERTIFICATE OF CONFORMITY

Certificate No.: CR-AOC-TUVNORD-26/0093-R00

Name and address of bearer /
manufacturer:

**İŞİLTİ ÇOCUK OYUN GRUPLARI
PLASTİK SAN. TİC. A.Ş.**

Büyükkayaçık OSB Mah. 416 Nolu Sk. İdari Bina No: 1 Selçuklu / Konya – TÜRKİYE

This certificate is issued on a voluntary basis and is not covered by accreditation. It does not represent an accredited conformity assessment result and is not within the scope of ILAC MRA. This document does not replace any regulatory requirement, CE marking or legal conformity assessment. The evaluation is limited to the referenced test report and/or assessed sample and does not cover factory production control, serial production or field conditions. TÜV NORD Turkey shall not be held responsible for installation, operation or in-use performance of the product

Inspected according to:

TS EN 1176-1:2023, TS EN 1176-2:2019, TS EN 1176-3:2018, TS EN 1176-4:2019, TS EN 1176-5:2019, TS EN 1176-6:2019, TS EN 1176-11:2014

Description of product:

Playground Equipment (This certificate is based solely on the evaluation of submitted documentation and/or tested sample.)

Model & Type:

- Playground Equipment [TS EN 1176-1]: BP-100 (BP-1XX), BT-100 (BT-1XX), EP-100 (EP-1XX), KP-100 (KP-1XX), KT-100 (KT-1XX), SK-600 (SK-6XX)
- Playground Equipment (Swings)[TS EN 1176-1/2]: SK-100 (SK-1XX), SK-400 (SK-4XX), SK-500 (SK-5XX), SK-300 (SK-3XX), SK-700 (SK-7XX)
- Playground Equipment (Swings / Slides) [TS EN 1176-1/2/3]: IP-200 (IP-2XX), YN-300 (YN-3XX), KRS-100 (KRS-1XX)
- Playground Equipment (Slides) [TS EN 1176-1/3]: AP-100 (AP-1XX), AR-100 (AR-1XX), BLK-100 (BLK-1XX), IP-100 (IP-1XX), IP-300 (IP-3XX), IP-400 (IP-4XX), IP-500 (IP-5XX), IP-600 (IP-6XX), IP-700 (IP-7XX), IP-800 (IP-8XX), IP-900 (IP-9XX), LK-100 (LK-1XX), MS-100 (MS-1XX), TRP-100 (TRP-1XX), TY-100 (TY-1XX), YN-100 (YN-1XX), YN-200 (YN-2XX), YN-300 (YN-3XX), YN-400 (YN-4XX), YN-500 (YN-5XX), YN-600 (YN-6XX), YN-700 (YN-7XX), YN-800 (YN-8XX), YN-900 (YN-9XX), ARB-100 (ARB-1XX), DN-100 (DN-1XX), EJD-100 (EJD-1XX), IH-100 (IH-1XX), IP-306, ITF-100 (ITF-1XX), KL-100 (KL-1XX), MRN-100 (MRN-1XX), MT-100 (MT-1XX), SQ-100 (SQ-1XX), TPC-100 (TPC-1XX), WD-100 (WD-1XX), IP-306
- Playground Equipment (Cableways) [TS EN 1176-1/4]: TF-100 (TF-1XX)
- Playground Equipment (Carousels) [TS EN 1176-1/5]: DM-100 (DM-1XX), DM-200 (DM-2XX), DM-300 (DM-3XX), DM-400 (DM-4XX), DM-500 (DM-5XX)
- Playground Equipment (Rocking) [TS EN 1176-1/6]: HP-100 (HP-1XX), HP-200 (HP-2XX), THV-100 (THV-1XX), THV-200 (THV-2XX), THV-300 (THV-3XX), THV-400 (THV-4XX), THV-500 (THV-5XX), ZP-100, ZP-101
- Playground Equipment (Spatial Network) [TS EN 1176-1/11]: PT-100 (PT-1XX)

Inspection date or period:

24.02.2026

Report number:

RP-AOC-TUVNORD-26/0092-R00

Place of manufacture:

Büyükkayaçık OSB Mah. 416 Nolu Sk. İdari Bina No: 1 Selçuklu / Konya – TÜRKİYE

Inspected by:

Besim BOZDAŞ

Istanbul , Issue Date : 24.02.2026

This certificate is valid between 24.02.2026 to 23.02.2027

Certifier for Product of TÜV NORD Turkey Teknik Kontrol ve Belgelendirme A.Ş.

Mr. MEHMET SELÇUK

TÜV NORD Turkey Teknik Kontrol ve Belgelendirme A.Ş.
Şehit Mehmet Fatih Ongül Sokak, No.5 Kat:4
Odak Plaza, Kozyatağı, 34742 İstanbul-
TÜRKİYE

Tel. +90-(0) 216 361 2995
Fax +90-(0) 216 380 67 87
e-mail tuv-nord@tuv-turkey.com

İSİLTİ
PARK

İŞİLTİ ÇOCUK OYUN GRUPLARI PLASTİK SAN. TİC. A.Ş.
Büyükkayaçık OSB Mah. 416 Nolu Sk. No:1 Selçuklu/KONYA
Tel: +90 332 502 10 79 E-mail: bilgi@isiltiplastik.com
Selçuk V.D. 468 058 7183 Ticaret Sicil No: 72098

ATTESTATION OF CONFORMITY

Certificate No.: RP-AOC-TUVNORD-26/0094-R00

Name and address of bearer /
manufacturer:IŞILTI ÇOCUK OYUN GRUPLARI
PLASTİK SAN. TİC. A.ŞBüyükkayacık OSB Mah. 416 Nolu SK. İdari Bina NO: 1
Selçuklu / KONYA – TÜRKİYE

This certificate is issued on a voluntary basis and is not covered by accreditation. It does not represent an accredited conformity assessment result and is not within the scope of ILAC MRA. This document does not replace any regulatory requirement, CE marking or legal conformity assessment. The evaluation is limited to the referenced test report and/or assessed sample and does not cover factory production control, serial production or field conditions. TÜV NORD Turkey shall not be held responsible for installation, operation or in-use performance of the product

Inspected according to:

TS EN 16630:2015

Description of product:

Permanently Installed Outdoor Fitness Equipment (This certificate is based solely on the evaluation of submitted documentation and/or tested sample.)

Model & Type:

- | | | |
|--|---------------------------------|---------------------------------|
| <input type="checkbox"/> BS-100 (BS-1XX) | <input type="checkbox"/> FT-100 | <input type="checkbox"/> FT-109 |
| <input type="checkbox"/> EFT-100 | <input type="checkbox"/> FT-101 | <input type="checkbox"/> FT-110 |
| <input type="checkbox"/> EFT-101 | <input type="checkbox"/> FT-102 | <input type="checkbox"/> FT-111 |
| <input type="checkbox"/> EFT-102 | <input type="checkbox"/> FT-103 | <input type="checkbox"/> FT-112 |
| <input type="checkbox"/> EFT-103 | <input type="checkbox"/> FT-104 | <input type="checkbox"/> FT-113 |
| <input type="checkbox"/> EFT-104 | <input type="checkbox"/> FT-105 | <input type="checkbox"/> FT-114 |
| <input type="checkbox"/> EFT-105 | <input type="checkbox"/> FT-106 | <input type="checkbox"/> FT-115 |
| <input type="checkbox"/> EFT-106 | <input type="checkbox"/> FT-107 | <input type="checkbox"/> FT-200 |
| <input type="checkbox"/> EFT-107 | <input type="checkbox"/> FT-108 | <input type="checkbox"/> FT-201 |

Inspection date or period:

24.02.2026

Report number:

RP-AOC-TUVNORD-26/0094-R00

Place of manufacture:

Büyükkayacık OSB Mah. 416 Nolu SK. İdari Bina NO: 1
Selçuklu / KONYA – TÜRKİYE

Inspected by:

Besim BOZDAŞ

Istanbul , Issue Date : 24.02.2026

This certificate is valid between 24.02.2026 to 23.02.2027

Certifier for Product of TÜV NORD Turkey
Teknik Kontrol ve Belgelendirme A.Ş

Mr. MEHMET SELÇUK

TÜV NORD Turkey Teknik Kontrol ve
Beygelendirme A.Ş.
Şehit Mehmet Fatih Ongül Sokak, No:5 Kat:4
Odak Plaza, Kozyatağı, 34742 İstanbul-
TÜRKİYE

Tel. +90-(0) 216 361 2995
Fax +90-(0) 216 380 67 87
e-mail tuv-nord@tuv-turkey.com

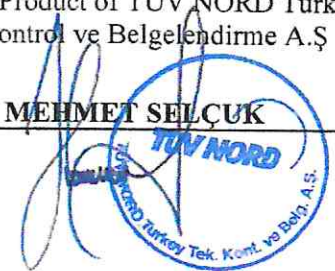
ISILTI
PARK

IŞILTI ÇOCUK OYUN GRUPLARI PLASTİK SAN. TİC. A.Ş.
Büyükkayacık Mah. 416 Nolu Sk. No:1 Selçuklu/KONYA
Tel: +90 332 502 70 79 E-mail: bilgi@isiltiplastik.com
Selçuk V.D. 468 858 7183 Ticaret Sicil No: 72098