

## ERG-H & ERG-EH Series

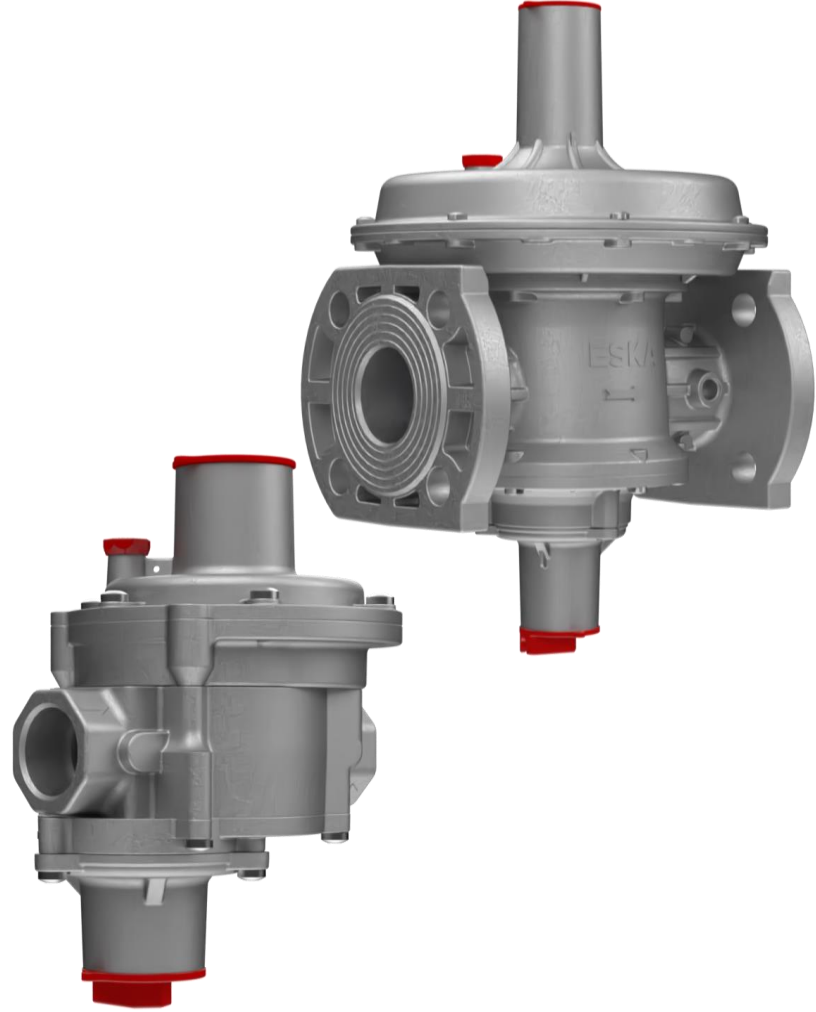

### ESKA

Sakarya 1. Organize Sanayi Bölgesi Mah. 11. Cad. No: 6-8, Arifiye/Sakarya/Türkiye  
Phone : +90 (264) 502 54 34-35-83 Fax : +90 (264) 502 54 84 E-mail : [info@eskavalve.com](mailto:info@eskavalve.com)

[www.eskavalve.com](http://www.eskavalve.com)

# Why ESKA?

With a deep understanding of the need for manufacturers to be close to gas distribution companies understanding their requirements and providing tailored solutions, ESKA grew to become a leading manufacturer of gas stream equipment. We start every day with a belief that change is constant, and the flexibility to follow that change and provide up to date solutions is crucial in the energy sector.

We manufacture gas stream equipment that are designed based on the needs of our partners. We strive to help gas distribution companies provide safe energy to their clients and to assist our partners with flexible business models that promote mutual growth.

Our commitment is to continually improve our products, ensuring the highest standards of safety and quality at an affordable cost, protecting end users while supporting our partners' success.



**60 Years Know-how**



**Global Reach in 65 Countries**



**Localized Support**

# Application Area

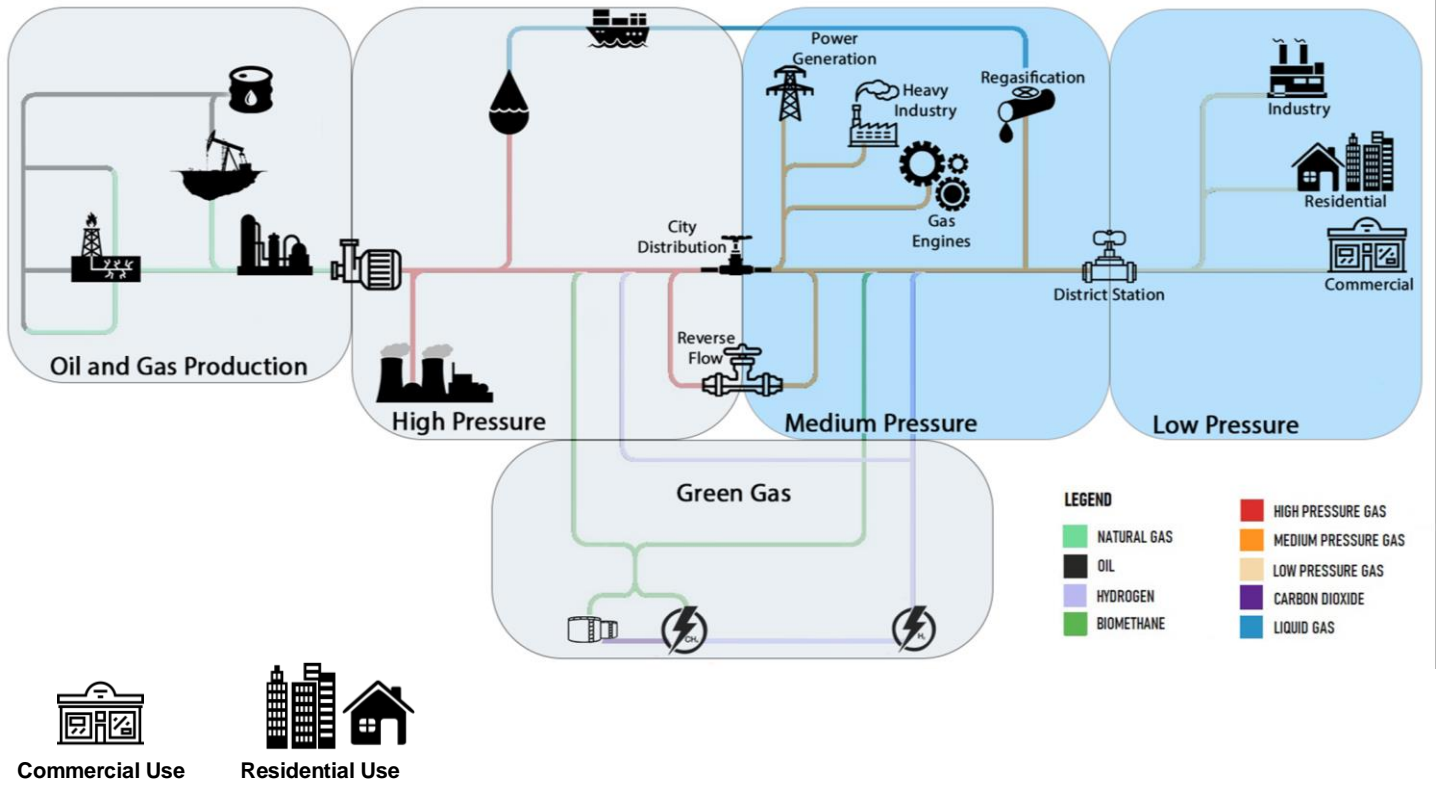

Figure 1: Gas Distribution Map

# Introduction

ERG-EH series gas pressure regulators with safety shut-off help the devices following it to operate safely in the gas line. The gas pressure regulator maintains the outlet pressure within the tolerance range by reducing the inlet pressure to the desired/adjusted outlet pressure, and if the outlet pressure increases or decreases to undesirable levels above the safety set pressure (within its tolerances), it automatically detects this situation and automatically cuts off the gas in the line and continues to remain closed until it is manually set again. The gas pressure regulator has a high pressure and low pressure gas safety shut-off device integrated into it. The low pressure safety shut-off device of these devices may not be integrated into the product if requested in the order. The gas pressure regulator may have a discharge system that opens to air if requested in the order, in which case the necessary precautions must be taken to prevent the discharged gas from filling the closed environment.

Note: ERG-H series products are gas pressure regulators without safety shut-off, unlike the information above. High and low pressure safety shut-off systems are not available in these series products. In case of using ERG-H series products, additional precautions should be taken against unwanted excessive pressure increases and decreases that may occur at the line outlet. ERG-EH and ERG-H series gas pressure regulators are single-stage, direct-operation principle, internal sensing, spring-driven. This product should be used in accordance with the current regulations and the user manual. The regulators are manufactured according to Ped Directive 2014/68/EU. The functional tests are performed according to EN 334

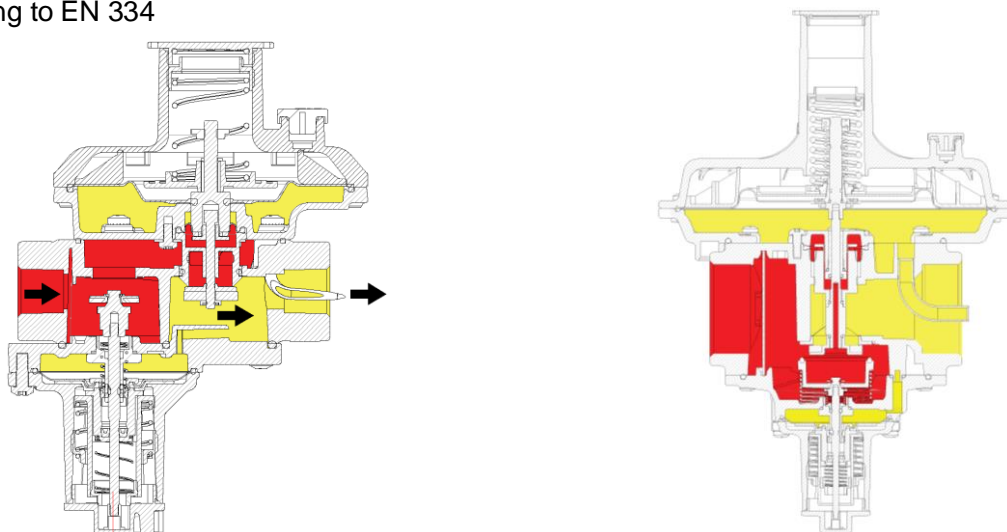

Figure 2: ERG-EH Pressure Display

# Features

ERG-EH series gas pressure regulators are used in the gas lines in order to reduce maximum 5 bar input pressure to the desired output pressure between 10 and 500 mbar. The range of the output pressure can be set with the choice of a different spring. The regulator with safety stopping gets automatically active and stops the gas flow in case that the input pressure gets higher or lower than the adjusted value in order to ensure the safety of the devices used in the system thanks to the safe stopping system it includes..



Figure 3: ERG-H (non-OPSO version)

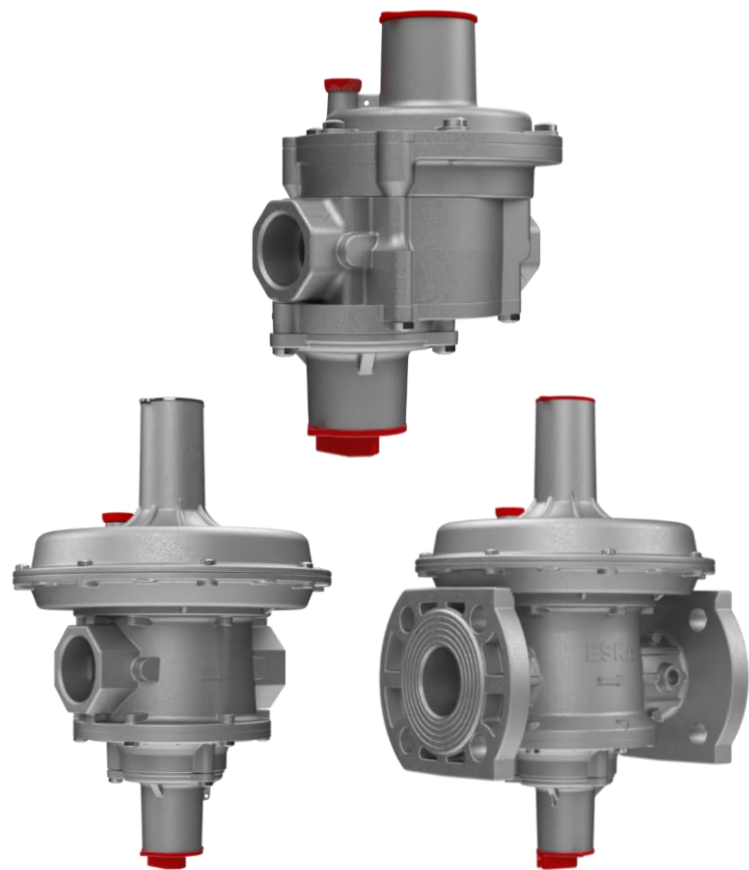

Figure 4: ERG-EH (OPSO version)

# Characteristics

Table 1: ERG-H Series characteristics

Feature	Values		
Design Pressure	PS1, PS2, PS3, PS4, PS5, PS6		
Inlet Pressure <sup>2</sup>	0.5 to 5 bar		
Flow	20 to 1400 m <sup>3</sup> /h		
Outlet Pressure Range (Wd) <sup>2</sup>	18 - 500 mbar		
Safety shut-off Pressure Range (Wdo-Wdu)	Wdo: 30 – 1000 mbar	Wdu: 7 - 180 mbar	
Accuracy Class (AC)	±10% AC10, ±5% AC5 <sup>1</sup> or ±20% AC20 <sup>1</sup>		
Lock-up over pressure (SG)	±10% SG10 <sup>1</sup> or ±20% SG20 <sup>1</sup> ±30% SG30		
	Standard Versions		LT Version <sup>4</sup>
Ambient temperature	-10°C to 50°C	-20°C to 60°C	-40°C to 60°C <sup>1</sup>
Configuration	Inline		
Connections	Standard Threaded Inlet (DN15, DN20, DN25, DN32, DN40, DN50) <sup>3</sup> and DN50 Flanged		
<sup>1</sup> Upon request <sup>1</sup> <sup>2</sup> The standard inlet and outlet pressure are set as per TS 10624, EN 334 <sup>3</sup> Different modular connection options include BSPP, BSPT and NPT. <sup>4</sup> The stated value is the temperature at which the device's mechanical resistance and leakage are tested. Extra body parts may not be suitable for that version.			

# Materials and Approvals

Table 2: ERG-H Series Materials and Approvals

Part	Material*	Standard
Body and Cover	Aluminium	EN 1706
Diaphragm and	Nitril Rubber	EN 549
Seat	Brass	EN 12164-EN12165
*Above materials are listed for standard models. For other request please refer to our sales team or your local distributor.		

The ERG-H Series regulator is designed according to European standard EN 334 and Turkish standard TS 10624. The regulator reacts in opening (Fail Open) according to EN 334. The product is certified according to European Directive 2014/68/EU (PED)



EN334



TS 10624



EN ISO  
4126-1



EN 14382



PED

# Technical Data

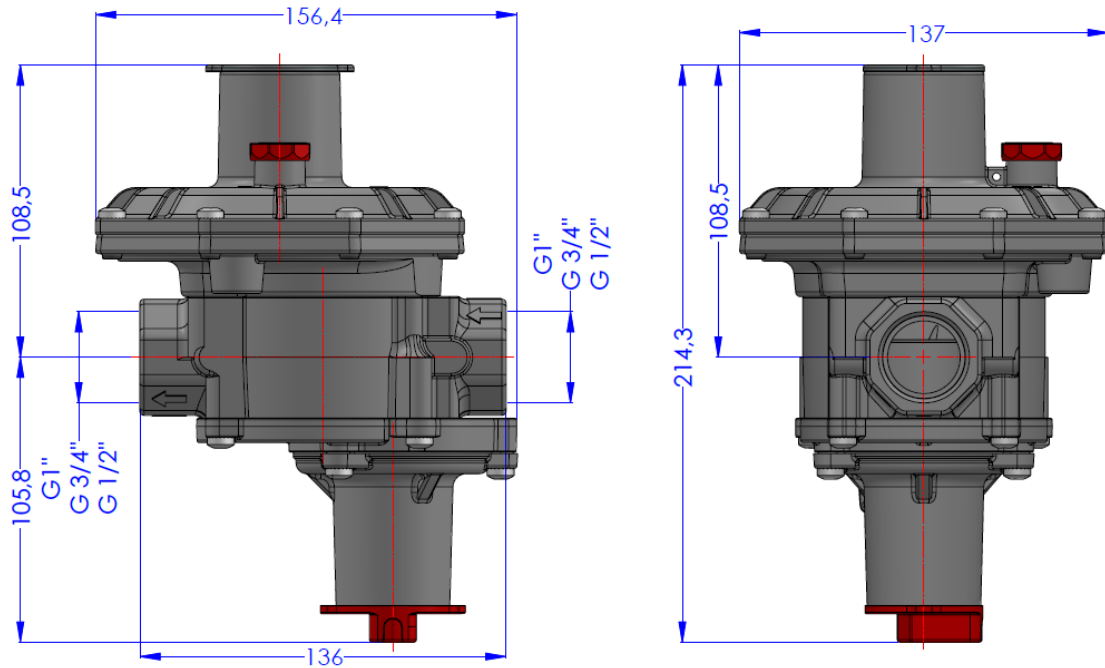

Figure 5: ERG-EH Technical Dimensions

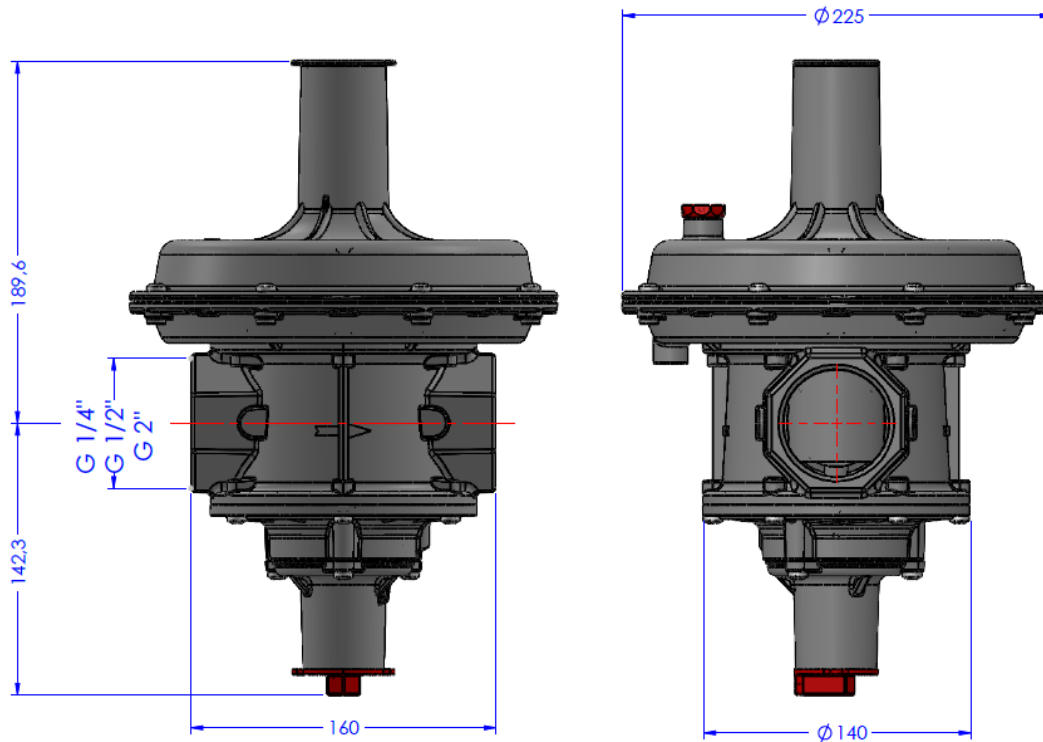

Figure 6: ERG-EH Technical Dimensions

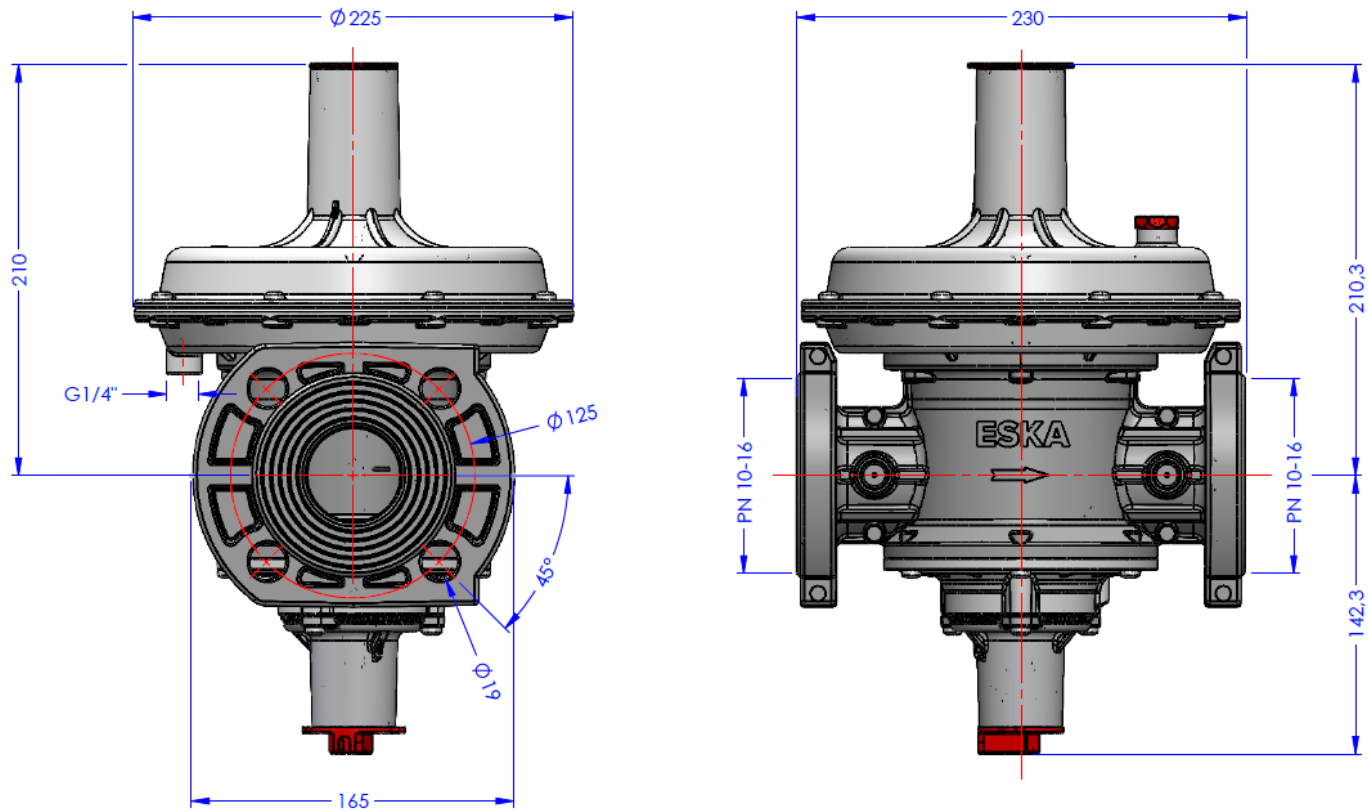

Figure 7: ERG-EH DN50 Flanged Technical Dimensions

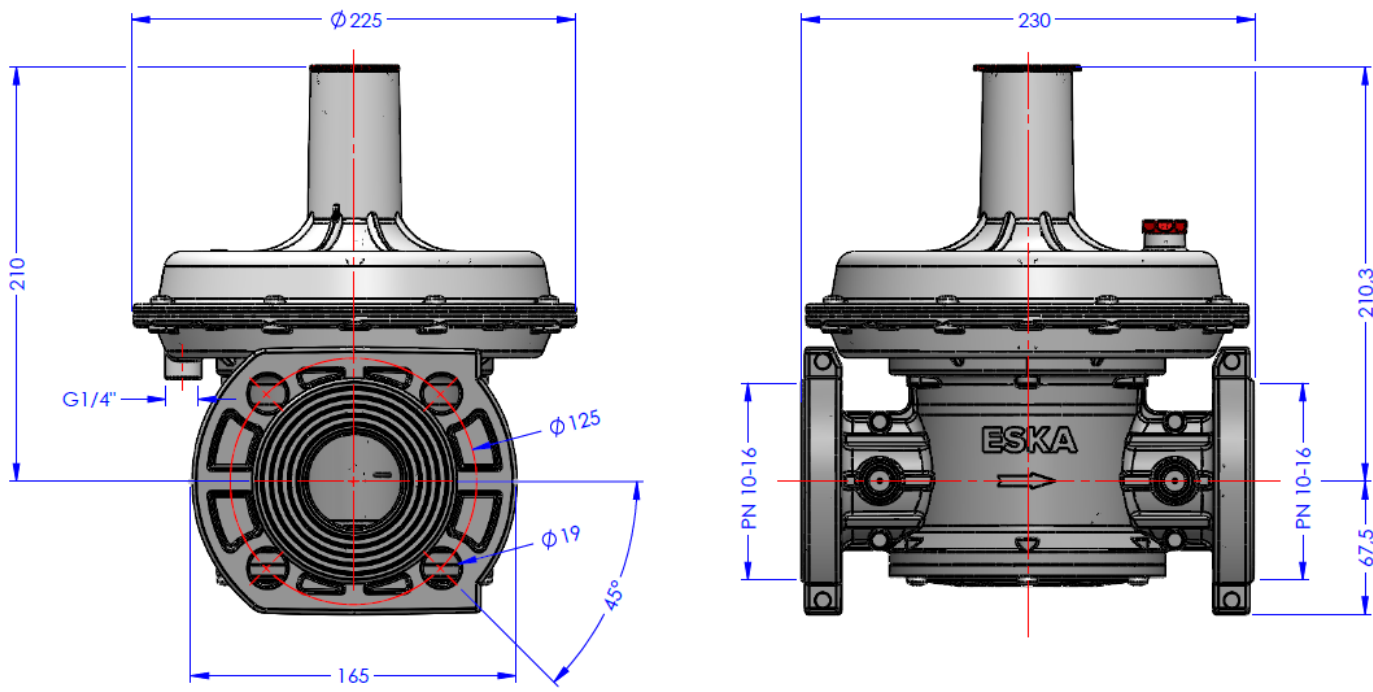

Figure 8: ERG-H DN50 Flanged Technical Dimensions

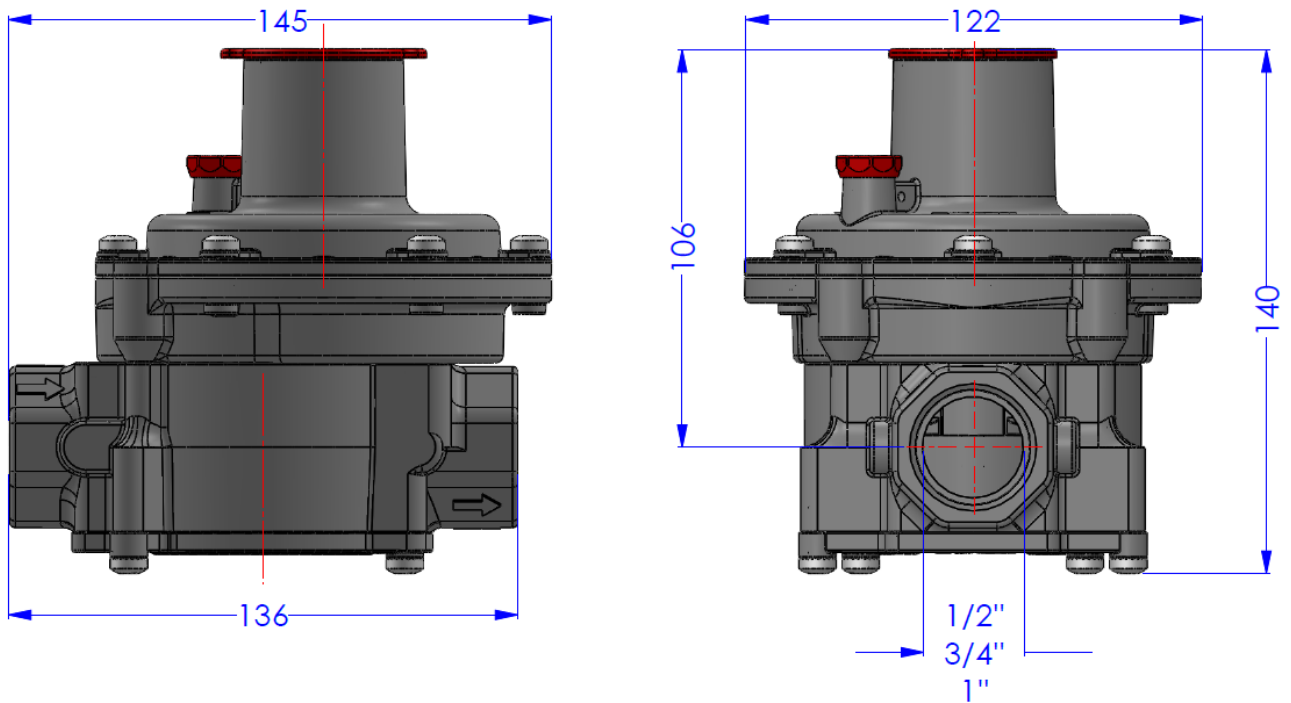

Figure 9: ERG-H Technical Dimensions

# Capacity Table

Table 3: ERG-H Series Capacity Tables

ERG-EH DN15																		
Inlet Pressure			Outlet Pressure															
			21(mbar)/2,1kPa		30(mbar)/3kPa		50(mbar)/5kPa		100(mbar)/10kPa		170(mbar)/17kPa		200(mbar)/20kPa		300(mbar)/30kPa		500(mbar)/50kPa	
barg	PSI	MPa	Sm <sup>3</sup> /h	Kg/h	Sm <sup>3</sup> /h	Kg/h	Sm <sup>3</sup> /h	Kg/h	Sm <sup>3</sup> /h	Kg/h	Sm <sup>3</sup> /h	Kg/h	Sm <sup>3</sup> /h	Kg/h	Sm <sup>3</sup> /h	Kg/h	Sm <sup>3</sup> /h	Kg/h
0,1	1,5	0,0	10	11	10	11	14	16	-	-	-	-	-	-	-	-	-	-
0,2	2,9	0,0	15	17	15	17	20	23	20	23	10	11	-	-	-	-	-	-
0,3	4,4	0,0	15	17	15	17	20	23	25	29	25	29	30	34	-	-	-	-
0,5	7,3	0,1	15	17	15	17	20	23	25	29	25	29	65	74	50	57	-	-
1,0	14,5	0,1	15	17	15	17	20	23	25	29	25	29	70	80	80	91	90	103
2,0	29,0	0,2	15	17	15	17	20	23	25	29	25	29	70	80	80	91	90	103
3,0	43,5	0,3	15	17	15	17	20	23	25	29	25	29	70	80	80	91	90	103
4,0	58,0	0,4	15	17	15	17	20	23	25	29	25	29	70	80	80	91	90	103
5,0	72,5	0,5	15	17	15	17	20	23	25	29	25	29	70	80	80	91	90	103

\* Values in the table are for AC10.  
 \* Kg/h values are for LPG  
 \* Sm<sup>3</sup>/h values are for Natural Gas

## ERG-EH DN20

Inlet Pressure			Outlet Pressure															
			21(mbar)/2,1kPa		30(mbar)/3kPa		50(mbar)/5kPa		100(mbar)/10kPa		170(mbar)/17kPa		200(mbar)/20kPa		300(mbar)/30kPa		500(mbar)/50kPa	
barg	PSI	MPa	Sm <sup>3</sup> /h	Kg/h	Sm <sup>3</sup> /h	Kg/h	Sm <sup>3</sup> /h	Kg/h	Sm <sup>3</sup> /h	Kg/h	Sm <sup>3</sup> /h	Kg/h	Sm <sup>3</sup> /h	Kg/h	Sm <sup>3</sup> /h	Kg/h	Sm <sup>3</sup> /h	Kg/h
0,1	1,5	0,0	15	17	15	17	17	19	-	-	-	-	-	-	-	-	-	-
0,2	2,9	0,0	20	23	20	23	30	34	35	40	35	40	-	-	-	-	-	-
0,3	4,4	0,0	25	29	25	29	40	46	45	51	45	51	35	40	-	-	-	-
0,5	7,3	0,1	25	29	25	29	40	46	45	51	45	51	70	80	50	57	-	-
1,0	14,5	0,1	25	29	25	29	40	46	45	51	45	51	100	114	90	103	110	125
2,0	29,0	0,2	25	29	25	29	40	46	45	51	45	51	100	114	100	114	110	125
3,0	43,5	0,3	25	29	25	29	40	46	45	51	45	51	100	114	100	114	110	125
4,0	58,0	0,4	25	29	25	29	40	46	45	51	45	51	100	114	100	114	110	125
5,0	72,5	0,5	25	29	25	29	40	46	45	51	45	51	100	114	100	114	110	125

\* Values in the table are for AC10.

\* Kg/h values are for LPG

\* Sm<sup>3</sup>/h values are for Natural Gas

## ERG-EH DN25

Inlet Pressure			Outlet Pressure															
			21(mbar)/2,1kPa		30(mbar)/3kPa		50(mbar)/5kPa		100(mbar)/10kPa		170(mbar)/17kPa		200(mbar)/20kPa		300(mbar)/30kPa		500(mbar)/50kPa	
barg	PSI	MPa	Sm <sup>3</sup> /h	Kg/h	Sm <sup>3</sup> /h	Kg/h	Sm <sup>3</sup> /h	Kg/h	Sm <sup>3</sup> /h	Kg/h	Sm <sup>3</sup> /h	Kg/h	Sm <sup>3</sup> /h	Kg/h	Sm <sup>3</sup> /h	Kg/h	Sm <sup>3</sup> /h	Kg/h
0,1	1,5	0,0	25	29	20	23	22	25	-	-	-	-	-	-	-	-	-	-
0,2	2,9	0,0	40	46	40	46	50	57	40	46	25	29	-	-	-	-	-	-
0,3	4,4	0,0	45	51	55	63	65	74	70	80	50	57	35	40	-	-	-	-
0,5	7,3	0,1	45	51	70	80	100	114	100	114	100	114	70	80	50	57	-	-
1,0	14,5	0,1	45	51	70	80	100	114	100	114	100	114	100	114	110	125	115	131
2,0	29,0	0,2	45	51	70	80	100	114	100	114	100	114	100	114	110	125	120	137
3,0	43,5	0,3	45	51	70	80	100	114	100	114	100	114	100	114	110	125	120	137
4,0	58,0	0,4	45	51	70	80	100	114	100	114	100	114	100	114	110	125	120	137
5,0	72,5	0,5	45	51	70	80	100	114	100	114	100	114	100	114	110	125	120	137

\* Values in the table are for AC10.

\* Kg/h values are for LPG

\* Sm<sup>3</sup>/h values are for Natural Gas

**ERG-EH DN32**

Inlet Pressure			Outlet Pressure															
			21(mbar)/2,1kPa		30(mbar)/3kPa		50(mbar)/5kPa		100(mbar)/10kPa		170(mbar)/17kPa		200(mbar)/20kPa		300(mbar)/30kPa		500(mbar)/50kPa	
barg	PSI	MPa	Sm <sup>3</sup> /h	Kg/h	Sm <sup>3</sup> /h	Kg/h	Sm <sup>3</sup> /h	Kg/h	Sm <sup>3</sup> /h	Kg/h	Sm <sup>3</sup> /h	Kg/h	Sm <sup>3</sup> /h	Kg/h	Sm <sup>3</sup> /h	Kg/h	Sm <sup>3</sup> /h	Kg/h
0,1	1,5	0,0	50	57	70	80	70	80	-	-	-	-	-	-	-	-	-	-
0,2	2,9	0,0	60	68	100	114	120	137	100	114	80	91	-	-	-	-	-	-
0,3	4,4	0,0	70	80	110	125	160	182	170	194	160	182	100	114	-	-	-	-
0,5	7,3	0,1	70	80	110	125	160	182	200	228	180	205	200	228	170	194	-	-
1,0	14,5	0,1	70	80	110	125	160	182	200	228	200	228	220	251	280	319	280	319
2,0	29,0	0,2	70	80	110	125	160	182	200	228	200	228	220	251	280	319	370	422
3,0	43,5	0,3	70	80	110	125	160	182	200	228	200	228	220	251	280	319	370	422
4,0	58,0	0,4	70	80	110	125	160	182	200	228	200	228	220	251	280	319	370	422
5,0	72,5	0,5	70	80	110	125	160	182	200	228	200	228	220	251	280	319	370	422

\* Values in the table are for AC10.  
 \* Kg/h values are for LPG  
 \* Sm<sup>3</sup>/h values are for Natural Gas

**ERG-EH DN40**

Inlet Pressure			Outlet Pressure															
			21(mbar)/2,1kPa		30(mbar)/3kPa		50(mbar)/5kPa		100(mbar)/10kPa		170(mbar)/17kPa		200(mbar)/20kPa		300(mbar)/30kPa		500(mbar)/50kPa	
barg	PSI	MPa	Sm <sup>3</sup> /h	Kg/h	Sm <sup>3</sup> /h	Kg/h	Sm <sup>3</sup> /h	Kg/h	Sm <sup>3</sup> /h	Kg/h	Sm <sup>3</sup> /h	Kg/h	Sm <sup>3</sup> /h	Kg/h	Sm <sup>3</sup> /h	Kg/h	Sm <sup>3</sup> /h	Kg/h
0,1	1,5	0,0	70	80	80	91	90	103	-	-	-	-	-	-	-	-	-	-
0,2	2,9	0,0	90	103	120	137	135	154	130	148	90	103	-	-	-	-	-	-
0,3	4,4	0,0	100	114	160	182	200	228	180	205	175	200	110	125	-	-	-	-
0,5	7,3	0,1	110	125	160	182	200	228	220	251	220	251	220	251	200	228	-	-
1,0	14,5	0,1	110	125	160	182	200	228	220	251	220	251	360	410	370	422	380	433
2,0	29,0	0,2	110	125	160	182	200	228	220	251	220	251	360	410	370	422	400	456
3,0	43,5	0,3	110	125	160	182	200	228	220	251	220	251	360	410	370	422	430	490
4,0	58,0	0,4	110	125	160	182	200	228	220	251	220	251	360	410	370	422	430	490
5,0	72,5	0,5	110	125	160	182	200	228	220	251	220	251	360	410	370	422	430	490

\* Values in the table are for AC10.  
 \* Kg/h values are for LPG  
 \* Sm<sup>3</sup>/h values are for Natural Gas

**ERG-EH DN50**

Inlet Pressure			Outlet Pressure															
			21(mbar)/2,1kPa		30(mbar)/3kPa		50(mbar)/5kPa		100(mbar)/10kPa		170(mbar)/17kPa		200(mbar)/20kPa		300(mbar)/30kPa		500(mbar)/50kPa	
barg	PSI	MPa	Sm <sup>3</sup> /h	Kg/h	Sm <sup>3</sup> /h	Kg/h	Sm <sup>3</sup> /h	Kg/h	Sm <sup>3</sup> /h	Kg/h	Sm <sup>3</sup> /h	Kg/h	Sm <sup>3</sup> /h	Kg/h	Sm <sup>3</sup> /h	Kg/h	Sm <sup>3</sup> /h	Kg/h
0,1	1,5	0,0	90	103	90	103	110	125	-	-	-	-	-	-	-	-	-	-
0,2	2,9	0,0	120	137	120	137	150	171	150	171	100	114	-	-	-	-	-	-
0,3	4,4	0,0	140	160	140	160	230	262	190	217	190	217	120	137	-	-	-	-
0,5	7,3	0,1	170	194	170	194	230	262	300	342	290	331	240	274	200	228	-	-
1,0	14,5	0,1	170	194	170	194	230	262	300	342	300	342	380	433	450	513	380	433
2,0	29,0	0,2	170	194	170	194	230	262	300	342	300	342	400	456	470	536	500	570
3,0	43,5	0,3	170	194	170	194	230	262	300	342	300	342	400	456	500	570	600	684
4,0	58,0	0,4	170	194	170	194	230	262	300	342	300	342	400	456	500	570	600	684
5,0	72,5	0,5	170	194	170	194	230	262	300	342	300	342	400	456	500	570	600	684

\* Values in the table are for AC10.  
 \* Kg/h values are for LPG  
 \* Sm<sup>3</sup>/h values are for Natural Gas

**ERG-EH FLANGED DN50**

Inlet Pressure			Outlet Pressure															
			21(mbar)/2,1kPa		30(mbar)/3kPa		50(mbar)/5kPa		100(mbar)/10kPa		170(mbar)/17kPa		200(mbar)/20kPa		300(mbar)/30kPa		500(mbar)/50kPa	
barg	PSI	MPa	Sm <sup>3</sup> /h	Kg/h	Sm <sup>3</sup> /h	Kg/h	Sm <sup>3</sup> /h	Kg/h	Sm <sup>3</sup> /h	Kg/h	Sm <sup>3</sup> /h	Kg/h	Sm <sup>3</sup> /h	Kg/h	Sm <sup>3</sup> /h	Kg/h	Sm <sup>3</sup> /h	Kg/h
0,1	1,5	0,0	160	182	135	154	160	182	-	-	-	-	-	-	-	-	-	-
0,2	2,9	0,0	250	285	240	274	200	228	220	251	100	114	-	-	-	-	-	-
0,3	4,4	0,0	315	359	285	325	225	257	280	319	190	217	120	137	-	-	-	-
0,5	7,3	0,1	370	422	380	433	310	353	350	399	290	331	240	274	200	228	-	-
1,0	14,5	0,1	370	422	380	433	330	376	300	342	300	342	380	433	450	513	380	433
2,0	29,0	0,2	380	433	450	513	510	581	300	342	300	342	400	456	470	536	500	570
3,0	43,5	0,3	430	490	510	581	510	581	300	342	300	342	400	456	500	570	600	684
4,0	58,0	0,4	430	490	550	627	600	684	300	342	300	342	400	456	500	570	600	684
5,0	72,5	0,5	290	330,6	290	330,6	340	387,6	430	490,2	600	684	600	684	800	912	850	969

\* Values in the table are for AC10.  
 \* Kg/h values are for LPG  
 \* Sm<sup>3</sup>/h values are for Natural Gas

To find the flows for other types of gases, the following formula should be used:

Adjustment Factor K at 15°C	
Butane	0,55
Propene	0,64
Oxygen	0,76
Air	0,78
Nitrogen	0,81
Biogas	0,85
City Gas	1,23
Hydrogen	3,04
LPG	0,62

Condition: +15°C, 1013 mbar,  
 $Q \text{ (n)m}^3/\text{h (naturalgas)} \times K = Q \text{ (n)m}^3/\text{h (x gas)}$   
 Example:  $Q \text{ (n)m}^3/\text{h (naturalgas)} \times 0,78 = Q \text{ (n)m}^3/\text{h (air)}$

# Regulation Spring Table

Table 4: ERG-H Series Regulation Spring Table

Type	Regulation Spring		LP Spring Range (mbar)		HP Spring Range (mbar)	
	Spring Code	Spring Color	Min.	Max.	Min.	Max.
DN15-DN25	PDM00003819	White	10	25	-	-
	PDM00003821	Green	18	30	-	-
	PDM00003822	Yellow	30	60	-	-
	PDM00003823	Blue	60	100	170	300
	PDM00003815	Red	100	170	300	500
DN32-DN50	PDM00003843	White	10	25	-	-
	PDM00003825	Yeşil	18	30	-	-
	PDM00003829	Yellow	30	60	-	-
	PDM00003832	Mavi	60	100	170	300
	PDM00003835	Red	100	170	300	500

# Relief Spring Table

Table 5: ERG-H Series Relief Spring Table

Type	Relief Spring		LP Spring Range (mbar)		HP Spring Range (mbar)	
	Spring Code	Spring Color	Min.	Max.	Min.	Max.
DN15-DN25	PDM00002239	Yellow	7	14	30	50
	PDM00002240	Red	15	32	50	80
	PDM00002244	Blue	33	60	80	140
	PDM00003817	Uncolored	60	100	140	240
DN32-DN50	PDM00003729	Red	7	14	30	50
	PDM00003726	Green	15	50	50	140
	PDM00003810	Blue	50	80	140	240

# OPSO Spring Table

Table 6: ERG-H OPSO Spring Table

OPSO Spring		Spring Range (mbar)	
Spring Code	Spring Color	Min.	Max.
PDM00002303	Red	30	60
PDM00002229	Black	60	100
PDM00002306	Black	100	300
PDM00003764	Red	300	700
PDM00004254	Black	600	1000
PDM00002172	Red	260	430
PDM00002102	Uncolored	100	160

# UPSO Spring Table

Table 7: ERG-H Series UPSO Spring Table

UPSO Spring		Spring Range (mbar)	
Spring Code	Spring Color	Min.	Max.
PDM00002189	Blue	7	22
PDM00002235	Red	22	50
PDM00002239	Yellow	50	110
PDM00002244	Blue	100	180

# Packaging

Table 8: ERG-H Series Packing Information

Product	Number or Items	Unit Weight	Package Size (LxWxH cm)	Number of Boxed Products in 1 Package	Total Package Weight	Pallet Total Items	Pallet Total Weight
ERG-H DN15- 25	1	Approximately 1,7 kg	50x50x29	8	Approximately 19,5 kg	192	Approximately 350 kg
ERG-H DN32-DN50	1	Approximately 4 kg	50x50x29	4	Approximately 16 kg	96	Approximately 385 kg

# ESKA



ERG-H / EH  
USER MANUAL

This manual is subject to change according to technical developments.

[www.eskavalve.com](http://www.eskavalve.com)