

ELECTRICITY METERS
TYPE NIK 2308
OPERATING MANUAL

Content

1	Description of meters and the principle of their operation	5
1.1.	Compliance with standards.....	5
1.2.	Designation.....	6
1.3.	General description of the measuring equipment	6
1.4.	Technical characteristics.....	12
1.4.1.	Dimensions of meters	12
1.4.2.	Meter connection schemes.....	12
1.4.3.	Technical characteristics of meters.....	12
1.5.	Resistance to mechanical influences and ignition	14
1.6.	Requirements for operating conditions.....	14
1.7.	Composition of meters.....	14
1.7.1.	Appearance of meters	14
1.7.2.	The design of meters.....	16
1.8.	The principle of operation	17
1.8.1.	Energy measurement	17
1.8.2.	Interaction of components	17
1.8.3.	Data storage	17
1.8.4.	Data display	17
1.8.5.	Controls	19
1.8.6.	Auxiliary Control Switch output	19
1.8.7.	Supply Control Switch.....	20
1.8.8.	Built-in clock	20
1.8.9.	Power supply of meters	21
1.8.10.	Features of the LTE cellular interface module	21
1.8.11.	Push notifications	21
1.9.	Meter parameterization.....	22
1.9.1.	Parameterization at the consumer.....	22
1.10.	Description of interfaces.....	23
1.11.	Rate module.....	24
1.11.1.	Active rate.....	24
1.11.2.	Rate plan of the day	24
1.11.3.	Rate plan of the week	24
1.11.4.	Rate plan for the season.....	24
1.11.5.	Lists of holidays.....	25
1.11.6.	Setting up rate plans	25
1.11.7.	Rate grids.....	25
1.11.8.	Change of rate plans	25
1.11.9.	Emergency rate	25
1.11.10.	Accumulation of data according to rates	26
1.12.	Load profiles.....	26
1.13.	Meter protection against unauthorized intervention	26
1.13.1.	Structural protection measures	26
1.13.2.	Cover and terminal cover opening sensors	26
1.13.3.	Data protection	27
1.13.4.	Magnetic field sensor.....	27
1.13.5.	Electromagnetic field sensor.....	27
1.14.	Marking	27
1.15.	Delivery set.....	31
1.16.	Packaging.....	31
2	Intended use.....	32
2.1.	Preparation of meters for use and their installation procedure	32
2.2.	Procedure for replacing the backup battery	34
2.3.	Types of conductors for connecting meters.....	34
2.4.	Use of meters.....	34
2.5.	Reading data	35

2.5.1. Options for reading data through interfaces	35
2.5.2. Exchange functionality through the interface.....	35
2.5.3. Exchange via optoport	36
2.5.4. Display of total energy and total power.....	36
2.6. Description of the windows displayed on the screen.....	36
2.6.1. The order of windows displaying	36
2.6.2. Manual viewing of windows	37
2.6.3. Indication of various modes of operation of meters	38
2.6.4. Indication of error codes.....	38
2.6.5. Examples of displayed windows	39
3 Maintenance.....	41
3.1. General instructions.....	41
3.2. Instructions for safety measures	41
4 Transportation and storage	41
4.1. Requirements for transportation of the product and storage of meters.....	41
5 Requirements for environmental protection and disposal of the device.....	41
6 Manufacturer's warranty	42
Appendix A. Overall and installation dimensions of the meter.....	43
Appendix B. Connection diagrams of the meter	44
Appendix C. Meters connection diagrams to networks and consumers	46
Appendix D. Table of OBIS codes that can be displayed on the screen	47
Appendix E. Error codes	51
Appendix F. List of events	56
Appendix G. Scheme of the rate grid of the meter	57

This operating manual (hereinafter - OM) applies to electricity meters of the type NIK 2308 (hereinafter - meters).

The operation of meters, their intended use, maintenance, storage and transportation is described in OM.

Service personnel must be specially trained, with an electrical safety permit not lower than III group when working on installations up to 1000 V.

1 Description of meters and the principle of their operation

1.1. Compliance with standards

Table 1 contains a list of standards to which meters of the type NIK 2308 meet the requirements.

Table 1. Standards

EN 62052-11	Electricity metering equipment - General requirements, tests and test conditions - Part 11: Metering equipment (IEC 62052-11)
EN 62053-21	Electricity metering equipment - Particular requirements - Part 21: Static meters for AC active energy (classes 0,5, 1 and 2) (IEC 62053-21)
EN IEC 62053-22	Electricity metering equipment - Particular requirements - Part 22: Static meters for AC active energy (classes 0,1S, 0,2S and 0,5S) (IEC 62053-22)
EN 62053-23	Electricity metering equipment - Particular requirements - Part 23: Static meters for reactive energy (classes 2 and 3) (IEC 62053-23)
EN IEC 62053-24	Electricity metering equipment – Particular requirements – Part 24: Static meters for fundamental component reactive energy (classes 0,5S, 1S, 1, 2 and 3)
EN 50470-1	Electricity metering equipment (a.c.) - Part 1: General requirements, tests and test conditions - Metering equipment (class indexes A, B and C)
EN 50470-3	Electricity metering equipment - Part 3: Particular requirements - Static meters for AC active energy (class indexes A, B and C)
EN 62059-32-1	Electricity metering equipment - Dependability - Part 32-1: Durability - Testing of the stability of metrological characteristics by applying elevated temperature
IEC 60721-3-3	Classification of environmental conditions – Part 3-3: Classification of groups of environmental parameters and their severities – Stationary use at weather protected locations
IEC 62053-52	Electricity metering equipment (AC) - Particular requirements - Part 52: Symbols
IEC 62052-31	Electricity metering equipment (AC) - General requirements, tests and test conditions - Part 31: Product safety requirements and tests
EN 61140	Protection against electric shock - Common aspects for installation and equipment
EN 60529	Degrees of protection provided by enclosures (IP Code)
EN 62056-53	Electricity metering - Data exchange for meter reading, tariff and load control - Part 53: COSEM application layer
EN 62056-61	Electricity metering – Data exchange for meter reading, tariff and load control – Part 61: Object identification system (OBIS)
EN 62056-62	Electricity metering – Data exchange for meter reading, tariff and load control – Part 62: Interface classes
EN 62056-21	Electricity metering –Data exchange for meter reading, tariff and load control – Part 21: Direct local data exchange

1.2. Designation

The meters, depending on the version, are intended for:

- non-rated or rated measurement of active and reactive energy in the forward and reverse direction in three-phase four-wire alternating current networks, with transformer operated or direct connected for voltage and current;
- registration and indication of active, reactive and total power, power factor, root mean square value of voltage and current, phase shift angle in three-phase four-wire alternating current circuits.

1.3. General description of the measuring equipment

Electric energy meters of the NIK 2308 type (hereinafter - the meters) are static three-phase electronic meters with an electronic display and three measuring elements, designed for non-rated or rated measurement of active and reactive electrical energy in forward and reverse directions in three-phase alternating current networks with direct or via transformer voltage and current connection.

The meters are used to organize the accounting of electric energy in the communal and household sector and in other sectors.

The complete list of values measured by meters, depending on the version, is given in Table 3 and Table 4.

Communication and Compliance

- The DLMS/COSEM standard with data encryption (and/or authentication) and without encryption is implemented in them.
- Meters comply with to requirements of IDIS package 2 type D.
- The meters meet the requirements of EN 50470-1:2006, EN 50470-3:2006, EN 62053-23:2003 (IEC 62053-23:2003), EN 62053-22:2003 (IEC 62053-22:2003), EN 62052-11:2003 (IEC 62052-11:2003), EN 62053-21:2003 (IEC 62053-21:2003), EN IEC 62053-22:2021, EN IEC 62053-24:2021.
- The meters meet the requirements of the EN 62059-32-1:2012 based on the results of stability and metrological reliability studies.

Accuracy Classes

The meters are designed for measuring active energy with:

- Accuracy class 1, according to EN 62053-21:2003.
- Accuracy class B or C (for NIK 2308 0.5S transformer operated meter versions), according to EN 50470-3:2006.
- Accuracy class 0,5 S, according to EN 62053-22:2003.
- Accuracy class 0,2 S, according to EN IEC 62053-22:2021.

When measuring reactive energy, the meters correspond to:

- Accuracy class 2, according to EN 62053-23:2003.
- Accuracy class 1 S, according to EN IEC 62053-24:2021.
- Meters with reactive energy accuracy class 1 S are only available in combination with active energy accuracy class 0,2 S (NIK 2308 0.2S).
- All other meter versions comply with reactive energy accuracy class 2.

European Directives Compliance

- The meters are in compliance with the requirements of Directive 2014/32/EU of the European Parliament and of the Council
- Meters with active accuracy class 0,2 S and reactive class 1 S comply with the requirements of Directives 2014/30/EU

Design Documentation

The meters comply with to design documentation AAIIX.411152.095.

Meter versions differ in nominal/reference voltage, maximum current, the ability to measure reactive energy, the ability to measure energy at several rates, the presence and type of an additional interface, the presence of magnetic and electromagnetic field sensors, the presence of a Supply Control Switch, the ability to measure active energy in the reverse direction, the number of measured values.

All meters are equipped with an optical port, electrical test pulse outputs, optical pulse test outputs, which also serve as LED indicators for energy measurement (active or active and reactive). The meters are equipped with a cover opening sensor and a terminal cover opening sensor. Multi-rate meters are equipped with a built-in backup power battery.

Depending on the version, meters can be equipped with an interface for remote data transmission: the first additional interface (or RS-485 or 4G/LTE) and the second additional RS-485 interface.

Various types of meters can be equipped with an Auxiliary Control Switch output or Supply Control Switch, magnetic field and (or) electromagnetic field sensor and outputs for discrete inputs. Various meter versions can measure energy only in the forward direction or both in the forward and reverse directions.

Resistive dividers are used as primary converters in the voltage circuit of each phase, and shunts or current transformers are used in the current circuit of each phase. All meters are equipped with an electronic display, which uses a liquid crystal display (LCD). The sequence of displaying data on the display is programmable.

Non-volatile memory is used to store data in meters.

An Auxiliary Power Supply is used to power the meters, which converts the rectified input voltage into the voltage required to power all nodes and modules of the meters.

To power the meters in the absence of voltage in the network, a backup power battery can be installed, as well as the possibility of connecting to Auxiliary Power Supply (to be installed by agreement

with the customer). The use of the 4G/LTE interface module in the meters (see table of versions) allows a message transmit about this event after the power supply voltage disappears. This possibility is provided by the use of an ionizer, which supports the operation of the module for some time after the supply voltage disappears. The message generated in this case makes it possible to understand that the connection with this meter was interrupted precisely because of the lack of power.

Table 2 describes all possible versions of meters.

Table 3. Values measured by multi-rate meters¹

No	Values that are measured	AR	A
1.	Active energy (A+), kWh for each rate and in total for all rates; for each phase and in total for all phases.	+	+
2.	Active energy (A-), kWh: for each rate and in total for all rates; for each phase and in total for all phases.	+	+
3.	Reactive inductive energy (A+R+), kVar hours: for each rate and in total for all rates; for each phase and in total for all phases.	+	-
4.	Reactive capacitive energy (A-R+), kVar hours: for each rate and in total for all rates; for each phase and in total for all phases.	+	-
5.	Reactive inductive energy (A-R-), kVar hours: for each rate and in total for all rates; for each phase and in total for all phases.	+	-
6.	Reactive capacitive energy (A+R-), kVar hours: for each rate and in total for all rates; for each phase and in total for all phases.	+	-
7.	Total energy S+, kVA -hours: for each phase and in total for all phases	+	-
8.	Total energy S-, kVA -hours: for each phase and in total for all phases	+	-
9.	Active energy A+ + A- , kWh: for each rate and in total for all rates; for each phase and in total for all phases	+	+
10.	Active energy A+ - A- , kWh: for each rate and in total for all rates; for each phase and in total for all phases	+	+
11.	Instantaneous value of the voltage on each phase, V	+	+
12.	The instantaneous value of the current in each phase, A	+	+
13.	The instantaneous value of the power factor $\cos \varphi$ for each phase. The arrows show the quadrant of the located vector	+	Only quadrant A+ or A- is displayed
14.	Instantaneous frequency value for each phase, Hz	+	+
15.	Instantaneous value of active power passing through the meter for each phase and in total for all phases, kW	+	+
16.	The instantaneous value of the reactive power passing through the meter for each phase and in total for all phases, kVar	+	-
17.	The total power of S+ and S- passing through the meter for each phase and in total for all phases, kVA	+	-
18.	Active power A+ + A- and A+ - A- passing through the meter for each phase and in total for all phases, kW	+	+
19.	Current time value	+	+

¹AR – meter version that measures active and reactive energy, A – meter version that measures only active energy;
The "+" sign indicates that this value is measured (displayed) by the meter;
The "-" sign indicates that this value is not measured (not displayed) by the meter.

Table 4. Quantities measured by single-rate meters²

No	Quantities that are measured	AR	A
1.	Active energy (A+), kWh: for each phase and in total for all phases.	+	+
2.	Active energy (A-), kWh: for each phase and in total for all phases.	+	+
3.	Reactive inductive energy (A+R+), kVar hours: for each phase and in total for all phases.	+	-
4.	Reactive capacitive energy (A-R+), kVar hours: for each phase and in total for all phases.	+	-
5.	Reactive inductive energy (A-R-), kVar hours: for each phase and in total for all phases.	+	-
6.	Reactive capacitive energy (A+R-), kVar hours: for each phase and in total for all phases.	+	-
7.	Total energy S+, kVA hours: for each phase and in total for all phases	+	-
8.	Total energy S-, kVA hours: for each phase and in total for all phases	+	-
9.	Active energy A+ + A- , kWh: for each phase and in total for all phases	+	+
10.	Active energy A+ - A- , kWh: for each phase and in total for all phases	+	+
11.	Instantaneous value of the voltage on each phase, V	+	+
12.	The instantaneous value of the power factor $\cos \varphi$ for each phase. The arrows show the quadrant of the located vector	+	Only quadrant A+ or A- is displayed
13.	The instantaneous value of the current in each phase, A	+	+
14.	Instantaneous frequency value for each phase, Hz	+	+
15.	The instantaneous value of the active power passing through the meter for each phase and in total for all phases, kW	+	+
16.	The total power of S+ and S- passing through the meter for each phase and in total for all phases, kVA	+	-
17.	Active power A+ + A- and A+ - A- passing through the meter on each phase and in total on all phases, kW	+	+

²AR – performance that measures active and reactive energy, A – performance that measures only active energy;
The "+" sign indicates that this value is measured (displayed) by the meter;
The "-" sign indicates that this value is not measured (not displayed) by the meter.

1.4. Technical characteristics

1.4.1. Dimensions of meters

The overall and installation dimensions of the meters are given in the "Appendix A. Overall and installation dimensions of meters".

1.4.2. Meter connection schemes

The meter connection schemes are given in the "Appendix B. Meter connection schemes" and "Appendix C. Meters connection to the consumer's network".

1.4.3. Technical parameters of meters

The main technical parameters of the meters are given in Table 5.

Table 5. The main technical parameters

Parameter	Value, description
Accuracy class for measurement of active energy (according to EN 62053-21)	1
Accuracy class for measurement of reactive energy (according to EN 62053-23)	2
Accuracy class for measurement of reactive energy (according to EN 62053-24)	1 S ⁵
Accuracy class for measurement of active energy (according to EN 62053-22)	0,5 S or 0,2 S
Accuracy class for measurement of active energy (according to EN 50470-3)	B or C
Nominal voltage/Reference voltage (subject to meter version) Un, V	3x220/380, 3x230/400, 3x240/416, 3x57,7/100...3x240 /416 ^{2,3} , 3x57,7/100 ^{2,3}
Voltage operating range, % of Un	from minus 20 to plus 15
Starting current for active energy Ist, mA;	12,5 ¹ 10 ² 5 ³
Starting current for reactive energy Ist, mA;	15,6 ¹ 15 ^{2,3} 10 ⁴
Minimum current Imin, A	0,25 ¹ 0,05 ^{2,3}
Transient current Itr, A	0,5 ¹ 0,25 ^{2,3}
Basic current Ib/Reference current Iref/Rated current In, A	5
Maximum current Imax, A (subject to meter version)	120 80 10
Nominal frequency/Reference frequency fn, Hz	50
Meter constant for active energy, imp/(kWh)	8000
Meter constant for reactive energy, imp/(kvarh)	8000
Power consumption of meter in voltage circuits for each phase, VA (W)	less than 10 (2)
Power consumption of meter in current circuits for each phase (at Ib, In, Iref), VA	less than 0,05
The number of LCD digits to display basic information	6+3

Parameter	Value, description
Register capacity, kWh	999999,999
Calibration interval, years	10
Rated metering of energy consumption	Based on the meter version is up to 4 rates and 12 rate seasons
Storage of the load profile with an integration period of 60 minutes, days	greater than 180
Storage of data on consumed energy for all rates at the end of the day, days	greater than 180
Storage of data on consumed energy for all rates at the end of the month, months	greater than 48
The basic absolute error of the built-in clock of the meter, s/day	± 0,5
Working temperature range, °C	from minus 40 to plus 70
Storage temperature range, °C	from minus 40 to plus 70
Relative air humidity at a temperature of plus 30 °C, %	no more than 95
Degree of protection	IP54
Mechanical class	M2
Electromagnetic class	E2
Weight, kg	less than 1,6
Average service life before the first overhaul, years	greater than 24
Average working time per failure (considering technical maintenance), h	greater than 200,000

Note:

- ¹ – for direct connected meters with accuracy class 1 and B of active energy measurement
- ² – for transformer operated meters with accuracy class 1 and B of active energy measurement
- ³ – for transformer operated meters with accuracy class 0,5 S, 0,2 S and C of active energy measurement
- ⁴ – for transformer operated meters with accuracy class 1 S of reactive energy measurement
- ⁵ – only for meters NIK 2308 0.2s

The main technical parameters of LTE interfaces are given in Table 6.

Table 6. Technical parameters of the LTE interface (E-UTRA)

Parameter	Value
GSM/GPRS cellular radio communication technology	
Transmitter/receiver frequency ranges, MHz - GSM-900 - DSC-1800	880,1 - 915/925,1 - 960 1710 - 1785/1805 - 1880
Class of GPRS communication	B
The maximum output power of the transmitter, less than, W - GSM-900 - DSC-1800	2 1
LTE cellular radio technology (E-UTRA)	
Transmitter/receiver frequency ranges, MHz: - Band 1 - Band 3 - Band 7 - Band 8 - Band 20	1920–1980/2110–2170 1710-1785/1805-1880 2500-2570/2620-2690 880-915/925-960 832-862/791-821

- Band 28	703-748/758-803
Maximum output power of the transmitter, W (dBm)	0,2 (23)
Antenna type	dedicated

1.5. Resistance to mechanical influences and ignition

In terms of resistance to mechanical influences, the meters belong to class M2 of the basic requirements of European Parliament and EC Directive 2014/32/EU

The degree of protection of the meter shell against the penetration of solid objects and water is IP 54 (EN 60529).

The material of the base, terminal cover and meter screw terminal complies with the UL94 - V0 standard - self-extinguishing within 10 seconds on a vertically mounted sample, drops of non-flammable particles are allowed.

The meter housing material complies with the UL94 - V2 standard by self-extinguishing within 30 seconds on a vertically installed sample, drops from burning particles are allowed.

1.6. Requirements for operating conditions

The meters can be operated in areas with "cold" and "moderately cold" climate types in climatic conditions of category 3K7 according to the classification according to IEC 60721-3-3 (with the exception of the possibility of moisture condensation and ice formation in the environment where they are operated).

The meters are intended for installation in an explosion-proof environment, without conductive dust and without aggressive gases. Meters can be placed in unheated rooms, as well as in cabinets of external installation, which provide protection from daily changes in climatic conditions and prevent moisture condensation and ice formation. It is forbidden to install meters under direct sunlight.

The value of relative humidity at 30 °C is less than 95%.

Temperature range:

- operation - from minus 40 to plus 70 °C;
- storage - from minus 40 to plus 70 °C.

1.7. Composition of meters

1.7.1. Appearance of meters

An example of appearance of meters type NIK 2308 and the arrangement of their control elements demonstrates Figure 1.



Figure 1. General appearance of the meter

The following elements are marked in the figure:

1. Optical pulse test output of active energy.
2. Electronic display of the meter.
3. Meter cover with nameplate.
4. "View" button.
5. "Select" button.
6. Sealing screws.
7. Seal of the meter.
8. External battery backup power.
9. Printed circuit board with electronic components.
10. Screw terminal.
11. Auxiliary Control Switch output.
12. SIM card installation adapter.
13. Contacts of the electric pulse test output when measuring active energy.
14. Contacts of the electric pulse test output when measuring reactive energy.
15. Terminal cover opening sensor.
16. Terminal cover.
17. Antenna connection point.
18. Optoport.

19. Optoport cover.
20. Numbered seal of the meter.
21. Optical pulse test output of reactive energy.

1.7.2. The design of meters

The meters are manufactured in a plastic insulating case of protection class II, which consists of a base and an opaque cover. The design of the meter base includes holes and a fastener for mounting the meters at the installation site.

A printed circuit board with a display, LED indicators, sensors, other electronic components and connectors is attached to the base. The nameplate is applied to the opaque cover by laser engraving.

The cover is attached to the base with two screws with the possibility of sealing them. There are special drains with holes in the cover of the meters for the meter sealing. In addition, the cover and base of the meters are fastened with a continuous seam using laser welding.

A screw terminal with primary voltage and current converters is also installed on the base. The presence of protective partitions between the phase terminals of the screw terminal ensures the impossibility of a short circuit between them. When connecting the meters to the corresponding clamps, the network wires and load wires are attached with screws. The screw terminal is closed with a cover. The cover of the screw terminal is attached to the base with the help of two screws with the possibility of sealing. The special drains with holes are provided in the screw terminal cover for sealing.

The printed circuit board also has connectors for the meter's test outputs, interface connectors, an SMA type connector for connecting an antenna, a SIM card slot, and a connector for the Auxiliary Power Supply. The presence of certain connectors is determined by the version of the meter. Access to them is possible only when the screw terminal cover is removed.



WARNING! The connector of the Auxiliary Power Supply is not galvanically isolated from the neutral.

The design of the case ensures the impossibility of removing the meter cover without removing the terminal cover.

Numbers corresponding to the factory number of the meter are applied to the base and cover. The same number is indicated on the nameplate, which makes it impossible to forge them. At the customer's request, it is possible to install a one-time number seal on one of the meter's fastening screws and apply (duplicate) the number of the specified seal on the meter case in the way that it covers both the cover and the base of the meter case.

Under the cover there is a compartment for an optical port and a slot for a SIM card. This compartment is closed with a cover that can be sealed with a separate seal. In the upper right corner of the meter cover, there are mechanical buttons "View" and "Select", intended for navigation through the menu of the meter display.

1.8. The principle of operation

1.8.1. Energy measurement

Active and reactive electrical energy is measured by analog-to-digital conversion of electrical signals coming from the primary current (shunt) and voltage (resistive dividers) converters to the input of the analog-to-digital converter (ADC) of the controller, which converts the signals into a digital code. The controller calculates the rms value of current, voltage, power, the current value of the power factor for each phase, as well as the value of active and reactive energy in total and for each rate.

1.8.2. Interaction of components

The controller controls the LCD, electrical, optical interfaces, electrical and optical test pulse outputs, and also processes information coming from mechanical buttons, sensors for opening the cover and terminal cover of meters, as well as sensors for magnetic and electromagnetic fields.

1.8.3. Data storage

Non-volatile memory is used to store data in meters. Accumulated electricity values and meter parameters are stored in the memory. The set parameters of the meters and accumulated energy values, in the absence of voltage on the terminals of the meters, must be stored for at least 20 years.

1.8.4. Data display

As an electronic display in the meters, seven-segment liquid crystal indicators with additional symbols are used. The appearance of an electronic display is shown Figure 2.

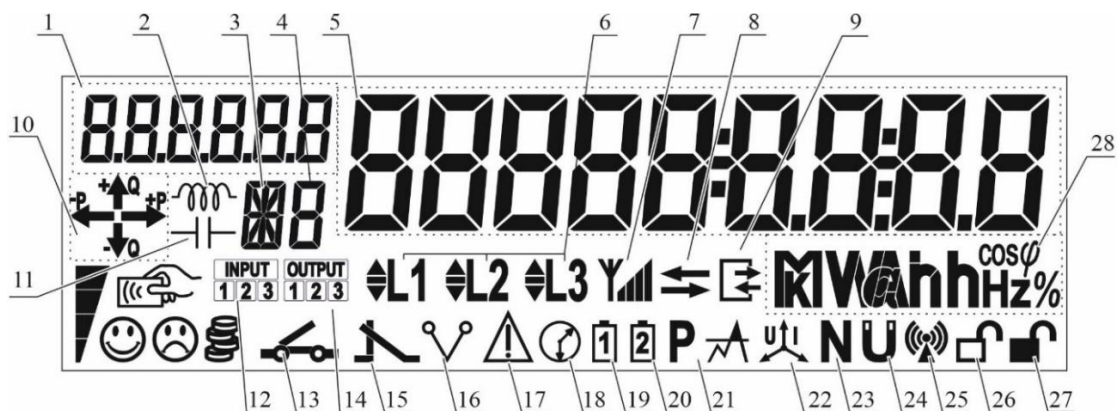
























Figure 2. Appearance of the LCD

The figure shows the following symbols and groups of symbols:

1. OBIS code indication group of the displayed parameter.

2. Indicator of reactive inductive energy.
3. The indicator of the type of rate; for example, \overline{T} is the designation of the usual rate.
4. Indicator of the rate number currently in effect.
5. Display group of the value of the measured parameter.
6. Indicators of the direction of current flow in phases L1, L2, L3.
7. GPRS or 4G connection status indicator. The number of dashes indicates the quality of the connection:
 25%,  50%,  75%, and  100%.
8. Indicator of data exchange through interfaces "  ".
9. Indicator of data exchange through the optical port.
10. A group of energy angle quadrant indicators:
 - 10.1. "  " active power (A+).
 - 10.2. "  " active power (A-).
 - 10.3. "  " vector of full power in the first quadrant (A+R+).
 - 10.4. "  " vector of full power in the second quadrant (A-R+).
 - 10.5. "  " vector of full power in the third quadrant (A-R-).
 - 10.6. "  " vector of full power in the fourth quadrant (A+R-).
 - 10.7. "  " reactive power (R+).
 - 10.8. "  " reactive power (R-).
11. Indicator of reactive capacitive energy.
12. Status indicator of discrete inputs.
13. Supply Control Switch status indicator:   – switch is open,   – switch is closed.
14. Status indicator of discrete outputs.
15. Auxiliary Control Switch output status indicator:  – switch output is closed,  – switch output is open.
16. Indicator of the operation of the meter according to the two-element scheme (three-phase meter).
17. The internal error indicator "  " flashes when an error occurs or during the emergency rate.
18. Clock failure indicator.
19. Internal backup battery discharge indicator. If the indicator lights up, the battery needs to be replaced.
20. External backup battery discharge indicator. If the indicator lights up, the battery needs to be replaced.
21. A group of indicators of exceeding the permissible load.
22. Phase misalignment indicator.
23. Neutral current mismatch indicator.

24. Indicator of the presence of magnetic radiation of the meter. A flashing indicator indicates the presence of magnetic radiation at the current moment. After the disappearance of the magnetic radiation, this indicator lights up continuously until it is switched off after the appropriate intervention using the software.
25. Indicator of the presence of electromagnetic radiation of the meter. A flashing indicator indicates the presence of electromagnetic radiation at the current moment. After the disappearance of the electromagnetic radiation, this indicator lights up continuously until it is switched off after the appropriate intervention with the help of the software.
26. Indicator of opening the screw terminal cover  .
27. Indicator of opening of the meter cover  .
28. Unit of measurement display group:
- 28.1. "**A**" current strength in amperes.
 - 28.2. "**V**" voltage in volts.
 - 28.3. "**kW**" active power in kilowatts.
 - 28.4. "**kVAr**" reactive power in kilowars.
 - 28.5. "**kWh**" active energy in kilowatt-hours.
 - 28.6. "**Hz**" network frequency.
 - 28.7. "**cosφ**" power factor.

LCD symbols not marked in the figure are not used in these meters.

1.8.5. Controls

On the front panel of the meters there are two mechanical buttons: "View" and "Select" (see Figure 1), designed to control the menu of the meter display. The activation of the button is accompanied by a sound signal from the internal speaker of the meters. The sound signal can be disabled during parameterization.

1.8.6. Auxiliary Control Switch output

Transformer operated meters can have an Auxiliary Control Switch output that allows you to switch an alternating voltage up to 250 V, with a current up 5 A. The diagram of its connection is shown in Figure 3, where R_L is the load that is connected to the switch terminal.

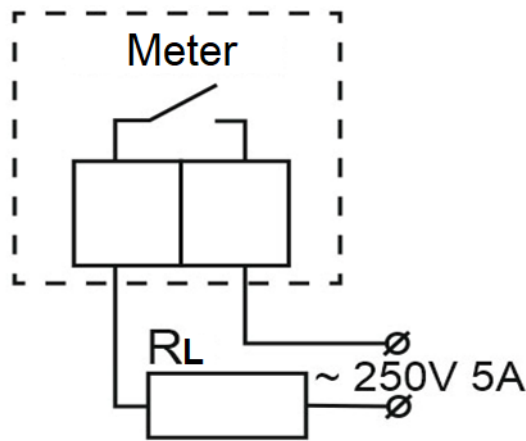


Figure 3. Connection diagram of the meter's Auxiliary Control Switch output

The switch operation is programmed in the following modes:

- normally open contacts are connected during the activity of the selected rate;
- normally open contacts are connected in 24 programmable intervals of the day;
- open at the request of the specified thresholds (upon exceeding the voltage, current, power);
- open when magnetic or electromagnetic field sensors are triggered (possible only if these sensors are available);
- opened and closed at the command of the operator.

1.8.7. Supply Control Switch

The meters, depending on the version, can be equipped with a Supply Control Switch. The operation of this switch is programmed in the following modes:

- normally open contacts are connected during the activity of the selected rate;
- normally open contacts are connected in 24 programmable intervals of the day;
- open at the request of the specified thresholds (upon exceeding the voltage, current, power);
- open when the magnetic or electromagnetic field sensor is activated (possible only if these sensors are available);
- opened and closed at the command of the operator.

Possible versions of meters with an installed Supply Control Switch are listed in the Table 2.

1.8.8. Built-in clock

Meters of multi-rate versions have a real-time clock (stabilized by a quartz resonator) with a calendar built into the microcontroller. The clock data is used for the operation of the rate system, the formation of the integration periods of the average power and the registration of events with a time stamp. The clock has the function of switching to winter and summer time. The time transfer can be carried out automatically or according to the date set during parameterization.

To reduce the dependence of the clock error on the ambient temperature, the meters are equipped with a temperature sensor.

1.8.9. Power supply of meters

A pulse power source is used to power the meters by converting the rectified input voltage into the voltage required to power all nodes and modules of the meters.

A backup battery is used to power the meter when there is no voltage in the network. In the absence of mains voltage, the meter automatically switches to a battery saving mode. In this mode, only the internal clock remains operational, and the total battery life can reach up to 10 years. Once the mains voltage is restored, the meter switches back to mains power, and the built-in battery is no longer used.

Multi-rate versions of meters can be additionally equipped with an external backup battery.

1.8.10. Features of the LTE cellular interface module

The use of the LTE cellular communication interface module in the meters (see the table of versions) allows you to transmit a message about the power supply voltage has disappeared. This possibility is provided by the use of an ionizer, which supports the operation of the module for some time after the supply voltage disappears. The message generated in this case makes it possible to understand that the connection with this meter was interrupted precisely because of the lack of power.

1.8.11. Push notifications

The meters have the ability to send push messages to the server thanks to the design features of the LTE modem and the extended functionality of the device software. Push notifications are sent during the following events:

- turning on or off the meter;
- loss of voltage in one, several or all phases;
- appearance of voltage on any of the three phases.

The sent notification contains the following parameters:

- meter serial number;
- active and reactive energy;
- voltage and current of each phase at the time of sending the message;
- errors in the meter at the moment.

It is possible to change these parameters only during factory parameterization of the meter. IP address and server port can be changed through UNIK 3.0 software.

When any of the above events are triggered, one message is sent. The exception is turning on the meter. When the meter is turned on, there will be two messages. The first message is sent when the meter

is powered on, the second message is sent after the three-phase voltage appears, when metrology has fully started.

1.9. Meter parameterization

During parameterization, meter configuration constants are entered into the meter memory. Parameterization is carried out through the optoport in two stages:

- factory parameterization;
- parameterization at the consumer.

The meter has two levels of access for changing and reading data and settings, which can only be used after entering a password:

- Operator access level can change all parameters except bar code and meter version; user password can be changed but factory password cannot be changed.
- The user access level can only read data from the meter about its parameters and settings.

1.9.1. Parameterization at the consumer

During parameterization at the consumer, constants that adapt the meter to local operating conditions are recorded in the meter's memory through an electrical interface or a radio channel.

An example of information recorded in the memory of meters is given in Table 7. Parameterization of meters at the consumer is carried out by the energy supply or authorized organization with the help of special software. Parameterization is possible only with a password with operator access rights.

Table 7. Information stored in the meter's memory

Parameter	Value	
	default	permissible
The speed of data exchange between the meter and the installed interface: RS-485 LTE	9600 baud 9600 baud	from 1200 to 19200 baud 9600 baud
Transmission speed for the optoport	9600 baud	9600 baud
Time to disconnect when the interface is inactive	120 s	from 1 to 250 s
Meter address: - senior "HI" - junior "LOW"	is generated based on the serial number of the meter	from 0 to 65535 from 11 to 26
User password Operator password	1111111111111111 2222222222222222	from 1 to 16 characters from 1 to 16 characters
Place of meter installation (Street)	-	from 0 to 100 characters
Place of meter installation (House)	-	from 0 to 100 characters
Place of meter installation (Apartment)	-	from 0 to 100 characters
Meter installation location (Owner)	-	from 0 to 100 characters

Parameter	Value	
	default	permissible
Values of voltage thresholds, upon exceeding which, for a time not less than the set one, the indication is turned on and the event is recorded in the meter's memory: - for direct and combined connection meters U _{max} U _{min} - for transformer operated meters type U _{max} U _{min}	253 V 176 V 67 V 46 V	from 40 to 600 from 40 to 600 from 40 to 600 from 40 to 600
The time after which the indication of the voltage exceeding the thresholds occurs, and the event is recorded in the meter's memory	5 s	from 1 to 250 s
Supply Control Switch operation	Disabled	Enabled or disabled
Sound signal in the meter	Enabled	Enabled or disabled
Options for switching to summer/winter time	automatic transition	- automatic transition; - transition to the specified month, day; - no switch
Number of rates	4	
Number of profiles per week	10	
Number of rate seasons	12	
Number of profiles of the day	16	
Holidays	30	

1.10. Description of interfaces

The meters have electrical pulse test outputs, an optical port interface, optical pulse test outputs that also serve as LED indicators for energy measurement and discrete input leads. Depending on the version up to two additional interfaces can be installed in the meters. The type and presence of interfaces is reflected in the version of the meters, which is indicated on the nameplate and in the passport (see Table 2).

A description of possible meter interfaces is given in Table 8.

Data from meters can be read simultaneously via all available interfaces.

Table 8. Possible interfaces

Interface	Description
RS-485	An asynchronous interface for a half-duplex multipoint communication line of the "common bus" type, in which data transmission is carried out using differential signals. The interface has a galvanic isolation of the communication line. The interface is compatible with the ANSI TIA/EIA-485-A:1998 standard Communication speed from 1200 to 19200 baud.
LTE	The interface is designed to work in LTE ³ cellular networks. Communication speed: 9600 baud

³To connect to the meter, you need a static IP address of the cellular provider.

Interface	Description
Discrete inputs	Electrical insulation strength of discrete inputs: <ul style="list-style-type: none"> • relative to the power supply network – 4kVac • relative to low-voltage interfaces - 1kVdc The maximum frequency of the signal supplied to the discrete input: 4 Hz. Passive state: the input is not connected to the common wire (COM). Active state: the input is connected to the common wire (COM).

1.11. Rate module

The rate module of the meter software can support up to 4 rates and register the energy measured by the meters in the active and reactive energy registers separately for each of the 4 rates.

The effect of each rate during the year is timed using the annual rate plan. The annual rate plan consists of daily rate plans, weekly rate plans and seasonal rate plans.

1.11.1. Active rate

All rates are numbered from 1 to 4. At each moment of the day, only one of the four possible rates can be in effect. This rate is called active, unlike other currently inactive rates.

1.11.2. Rate plan of the day

The rate plan of the day is a numbered sequence and the activation time of one or another rate during the day. The rate module allows you to configure up to 12 changes of the active rate during the day and supports up to 16 different rate plans of the day. The numbering of rate plans of the day is from 1 to 16. Each rate change during the day is specified by the moment of activation of the rate (hours, minutes, seconds) and the number of this rate (from 1 to 4).

1.11.3. Rate plan of the week

The rate plan of the week allows you to assign one of the 16 possible rate plans of the day to each day of the week. The rate module of the meter supports up to 10 different rate plans of the week. Numbering of rate plans of the week from 1 to 10. For each day of the week, the number of the selected rate plan of the day is indicated. Daily rate plans change during the week at the change of day, at 00:00:00 according to the built-in real-time clock. The current rate plan of the week is called active.

1.11.4. Rate plan for the season

The rate module of the meter allows you to divide the calendar year into seasons (up to 12 different rate seasons are supported) and assign each of them its own rate plan. The rate plan of the season (or rate season) describes the sequence and time of change of the weekly rate plans during the season. Rate seasons

are numbered from 1 to 12. The currently valid rate season is considered active. The rate season is defined by the moment of activation of the season and the number of its rate plan.

1.11.5. Lists of holidays

The rate module allows you to support up to 30 separate daily rate plans for special days (numbered from 1 to 30). The moment of activation of daily rate plans for special days is set for a specific date in the month-day format, unlike ordinary daily rate plans, the change of which happens consistently when the day of the week changes. Rate plans like this allow you to configure rate switching for special days, for example, holidays. When a corresponding holiday date appears on the built-in clock and calendar, the rate change will be performed according to the holiday daily plan. That means that the holiday daily plan will be active, and not the usual one, which should be activated on the corresponding day of the week.

1.11.6. Setting up rate plans

Setting of daily, weekly, seasonal and holiday rate plans is performed by parameterizing meters using special software. When configuring, the parameters of each rate plan of the day, week, season, and holiday are set, and thus, the sequence and time of activation of one or another rate within the limits of the day, week, season, or in the event of the set holiday date are set.


1.11.7. Rate grids

The set of configured rate plans (days, holidays, weeks and seasons) that are active at the moment is called an active annual rate plan, or an active rate grid. It is not possible to edit the active rate grid. The rate module of the meter software allows you to additionally configure one more, currently passive, rate grid. It can be activated later. In this way, it is possible to make the necessary changes to the rate plans. Appendix G describes the scheme of the rate grid.

1.11.8. Change of rate plans

The rate module of the meter software tracks the moments of activation of the relevant rates, monitoring the current time, day of the week and date using the built-in real-time clock and calendar. The corresponding rate is activated when the time set in the rate plans of the day, week, season or holiday arrives, and it is valid until the moment of activation of the next rate. At the same time, all accumulated data are entered into the registers of the current rate.

1.11.9. Emergency rate

In the event of a failure of the built-in real-time clock, the meter automatically turns on the emergency rate, and all calculated energy values are recorded in the emergency rate registers, while the corresponding symbol ( rate icon and number) flashes on the electronic display. The number of the emergency rate is set during parameterization.

1.11.10. Accumulation of data according to rates

The measured values of the energy parameters are stored in the corresponding registers in the meter's memory. The rate module for each rate provides a separate set of registers for the accumulation of values of energy parameters.

1.12. Load profiles

To collect statistical data on energy consumption during meter operation, in advance, at the stage of its parameterization, you can create a load profile. A load profile is a list of measured values (up to 8 values), for which the integration period is specified. The values of the measured values included in the load profile will be periodically (with the specified period) recorded and stored in the corresponding memory registers of the meter. Accumulated information can be read from the meter using appropriate software through available interfaces.

The integration period when parameterizing the load profile is set in minutes from a series of fixed values 1, 2, 5, 10, 15, 20, 30, 60 min.

The depth of storage of the load profile of each type of measured energy depends on the integration period and for the configured longest period of 60 minutes can be up to 180 days.

1.13. Meter protection against unauthorized intervention

1.13.1. Structural protection measures

The cover and terminal cover of the meter clamps are attached to the base with sealing screws. The groove along the perimeter of the base ensures that the base and cover overlap at a connection of at least 4 mm, which excludes unauthorized access to the measuring part of the meters without damaging the case. At the request of the customer, the meter case can be welded.

On the cover of the optical port, as well as on the cover of the meters, there are special spaces with holes, which allow, if necessary, to additionally seal the case with the backup battery and the optical port from the closed state.

1.13.2. Cover and terminal cover opening sensors

The cover opening sensor is installed at the request of the customer. The terminal cover opening sensor is installed on all meters. The opening of the meter cover or the terminal cover is registered by the meter cover opening sensor and the terminal cover opening sensor respectively, and is registered in the meter event log (see 0). When the cover opening sensor is activated, the symbol "🔒" appears on the display. When the terminal cover opening sensor are triggered, the symbol "🔓" appears on the display ⁴.

⁴Registration of activation of the terminal cover opening sensor and cover opening sensor is not carried out when the power supply of the meter is disconnected (No supply voltage or discharged backup battery)

1.13.3. Data protection

Data protection is carried out by software. Meter data is available for writing and reading through interfaces and optoport only after entering a password. After entering the wrong password 5 times in a row, the meter is blocked for 30 minutes. Each such event is registered in the field log of the meter.

1.13.4. Magnetic field sensor

The magnetic field sensor, which can be equipped on meters, is activated when exposed to a permanent magnetic field with a level of more than 100 mT. If the duration of exposure is more than 3s, a message periodically appears on the meter display **ΠΠΡΓΗ**, and a record of this event is recorded in the meter's event log. If the sensor detects repeated exposures to a magnetic field of the same level within 60 seconds after the first exposure, then 60 seconds after the end of the last exposure a record of the effect of the magnetic field will be created in the event log, recording their total duration. If the pause between the effects of the magnetic field is longer than 60 seconds, then each of them will be recorded in the logbook with a separate entry recording the duration of each of them.

1.13.5. Electromagnetic field sensor

The electromagnetic field sensor, which can be equipped on meters, is activated when exposed to an electromagnetic field with a strength of more than 10 V/m in the frequency range from 80 to 2000 MHz. If the duration of exposure is more than 3 seconds, a message will periodically appear on the meter display **ΕΡΔ, α**, and a record of this event will be recorded in the meter's event log. If the sensor registers repeated effects of an electromagnetic field of the same intensity within 60 seconds, then 60 seconds after the end of the last of exposure, a record of the action of the electromagnetic field with registration of their total duration will be created in the event log. If the pause between the effects of the electromagnetic field is longer than 60 seconds, each of them will be recorded in the logbook with a separate entry recording the duration of each of them.


Notifications about the activation of sensors can be turned off only with the help of the "NIK Parameterization" program (with entering a valid password) by sending a special command through any available interface of the meter.




1.14. Marking

The marking of the meter corresponds to EN 62053-52, EN 62053-21, EN 62052-11, EN 62053-23, EN 50470-1, EN 50470-3 and the documentation of the manufacturer.

The possible symbols indicated on the nameplate of the meter, depending on the version, are described in Table 9.




Table 9. Symbols on the meter nameplate

	symbol of a meter with three measuring elements;
---	--

	symbol of a meter with two measuring elements;
	symbol of meters in the protection class II insulating case;
	symbol for transformer-operated meters;

The table with markings of installed interfaces and switches outputs (see Table 10) includes alphanumeric designations and symbols described in Table 10.

Table 10. Description of symbols of interfaces and switches on the nameplate

Symbol	Description
RS-485, LTE	the presence of a corresponding interface;
	the presence of an optoport;
	the presence of Auxiliary Control Switch output;
	the presence of Supply Control Switch;

The meter connection diagram is printed on the nameplate or on the inside of the meter terminal cover. The connection diagrams for all types of meters are given in the appendices "Appendix B. Meter connection schemes" and "Appendix B. Connecting meters to the consumer's network".

The current and voltage transformation coefficients in the transformer-operated meters are displayed on the display. OBIS codes for current and voltage transformation coefficients are 0.4.2 and 0.4.3, respectively (see "Appendix D. Table of OBIS codes that can be displayed on the screen"). The presence of menu items with transformation coefficients and their values are specified during meters parametrization.

Figure 4 and Figure 5 show the nameplate design of NIK 2308 meters type.

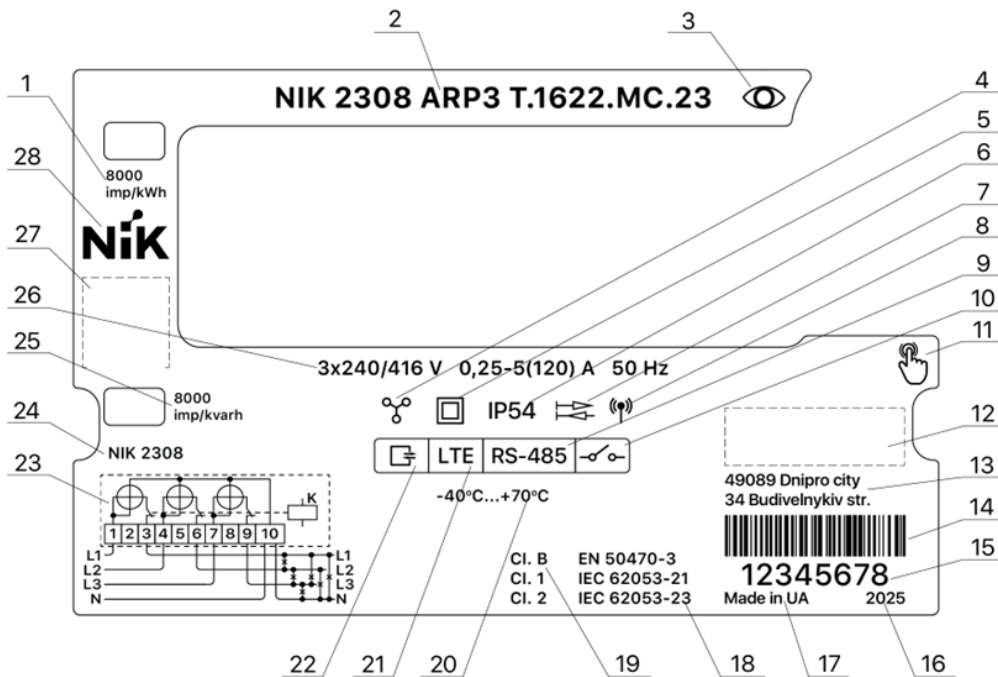


Figure 4. An example marking of the nameplate of meters type NIK 2308 with direct connected

The following elements are marked on the figure:

1. Designation of the optical test pulse output when measuring the active energy (meter's constant, when measuring active energy).
2. Conventional notation of meter version.
3. Designation of the "View" button.
4. Designation of the number of measuring elements.
5. Designation of protection class II.
6. Ingress protection (IP) code of the meter.
7. Designation of the bidirectional meter.
8. Symbol of the antenna for meters with LTE interface.
9. Marking of the presence and type of the second additional interface.
10. Marking of the Supply Control Switch presence.
11. Designation of the "Select" button.
12. A place for applying the mark of conformity assessment and additional metrological marking.
13. Address of the manufacturer.
14. Space for meter barcode.
15. Factory number according to the manufacturer's numbering system.
16. Year of manufacture of the meter.
17. The inscription "Made in Ukraine".
18. Designation of meter standards for accuracy classes when measuring active and reactive energy.
19. Designation of meter accuracy classes when measuring active and reactive energy.
20. The operating temperature ranges.
21. Marking of the presence and type of the first additional interface.
22. Marking of the presence of an optical port.
23. Connection diagram.
24. Meter type designation.
25. Designation of the optical pulse output when measuring the reactive energy (meter's constant, when measuring reactive energy).
26. Basic technical characteristics (nominal/reference voltage, minimal/basic/reference/rated and maximum current, nominal/reference frequency).
27. Area for DLMS and IDIS icons.
28. Registered trademark.

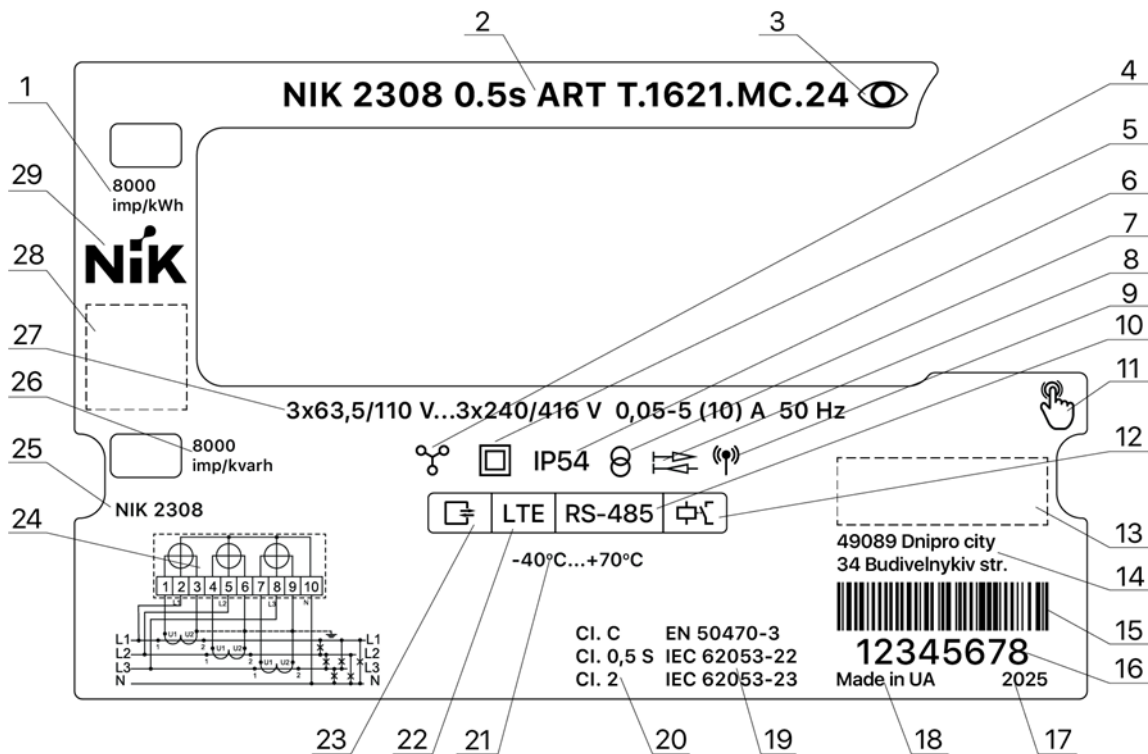


Figure 5. An example marking of the nameplate of the transformer operated meters type NIK 2308

The following elements are marked on the figure:

1. Designation of the optical test pulse output when measuring the active energy (meter's constant, when measuring active energy).
2. Conventional notation of meter version.
3. Designation of the "View" button.
4. Designation of the number of measuring elements.
5. Marking of the presence of an optical port.
6. Ingress protection (IP) code of the meter.
7. Designation of transformer connection meter.
8. Bidirectional meter designation.
9. Symbol of the antenna for meters with LTE interface.
10. Marking of the presence and type of the second additional interface.
11. Designation of the "Select" button.
12. Marking of the Auxiliary Control Switch output presence.
13. A place for applying the mark of conformity assessment and additional metrological marking.
14. Address of the manufacturer.
15. Space for meter barcode.
16. Factory number according to the manufacturer's numbering system.
17. Year of manufacture of the meter.
18. The inscription "Made in Ukraine".

19. Designation of meter standards for accuracy classes when measuring active and reactive energy.
20. Designation of meter accuracy classes when measuring active and reactive energy.
21. The operating temperature ranges.
22. Marking of the presence and type of the first additional interface.
23. Marking of the presence of an optical port.
24. Connection diagram.
25. Meter type designation.
26. Designation of the optical test pulse output when measuring the reactive energy (meter's constant, when measuring reactive energy).
27. Basic technical characteristics (nominal/reference voltage, minimal/basic/reference/rated and maximum current, nominal/reference frequency).
28. Area for DLMS and IDIS icons.
29. Registered trademark.

1.15. Delivery set

The delivery set is indicated in table 11.

Table 11. Meter delivery set

Name	Number
Electricity meter NIK 2308 (of the appropriate version)	1 pc.
Antenna Quectel Y1NIK00A0AA with 2 m cable	1 pc.
Passport AAIIX.411152.095 PS *	1 copy
Instruction manual AAIIX.411152.095 OM*	1 copy
Software**	1 pc.
Consumer packaging	1 pc.
Declaration of Conformity	1 copy
* Can be downloaded electronically from the manufacturer's website https://nik-el.com . Other options for delivery of operational documentation are reflected in the supply contract. **According to the supply contract.	

1.16. Packaging

One meter with operational documentation is placed in the consumer container.

The consumer container containing the meter is pasted with adhesive tape. A packing sheet is pasted on the top of the consumer container.

Another version of the meter packaging is carried out at the request of the customer and specified in the supply contract.

Meters packed in consumer containers are placed in transport containers. The shipping container is also packed with accompanying documentation, including a packing list containing the following information:

- the inscription "Made in Ukraine";
- trademark of the manufacturer;
- name and conventional designation of meters;
- number of packed meters;
- signature or personal seal of the packer;
- TCD mark of the manufacturing enterprise;
- gross mass, in kilograms;
- packing date

The overall dimensions of consumer containers do not exceed 265 mm x 180 mm x 88 mm.

The dimensions of the transport container do not exceed 372 mm x 277 mm x 457 mm.

Gross weight is less than 2,0 kg.

2 Intended use

2.1. Preparation of meters for use and their installation procedure

Meters should be installed in premises that meet the requirements of section " 1.6 Requirements for operating conditions".

Installation, removal, connection and disconnection of meters can be performed only by an organization authorized for these operations.

The organization authorized to perform installation, maintenance and removal of meters bears full responsibility for the fact that its personnel have carefully studied this manual, have sufficient qualifications to perform the work, and strictly comply with the requirements of local regulations on safety and operation of electrical installations.

Installation, removal, connection, disconnection and maintenance of meters must be performed in accordance with the current rules of operation of electrical installations and safety equipment, only by qualified personnel in accordance with the requirements of this document.

Installation, removal, connection and disconnection of meters must be performed by personnel with not lower than the third qualification group according to the rules of safe operation of electrical installations of consumers.

Installation and connection of the meter is performed in the following sequence:

1. Before installing the meter, it is necessary to de-energize the electrical network;
2. Unpack the meter and make sure that there is no mechanical damage, and the integrity of the seals.

3. For meters equipped with an LTE module, insert a SIM card into the corresponding slot of the meter. The mutual location of the slot and the SIM card during its installation is shown in Figure 6. In the figure, a hint about the correct position of the SIM card is highlighted with a red circle. Only SIM cards of the Mini-SIM type (ISO/IEC 7810:2003, ID-000) should be used. It is not recommended to use hybrid SIM cards with perforations of other sizes, as well as adapters of Micro-SIM and Nano-SIM sizes.

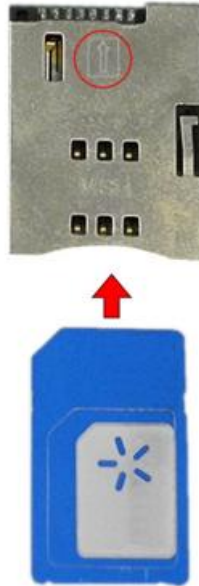


Figure 6. The mutual location of the slot and the SIM card

4. Fix the meter at the accounting point. The meter is installed on a DIN rail and fixed with two fasteners. It is also possible to install the meter at the metering point with the help of three screws according to Figure 1. The type of DIN rail is NS 35/ 7,5, a standard metal rail with a width of 35 mm of a special profile.

5. Connect the meter in accordance with the diagrams shown on the terminal cover (or on the nameplate) and in the appendices "Appendix B. Meter connection schemes" and "Appendix C. Connecting meters to the consumer's network". To connect transformer-type meters with a nominal voltage of a wide range (3x57,7...240/100...416 V) to the network according to the triangle scheme with two current transformers (Figure C. 4), it is necessary to set the operation mode of the meter with three-wire networks using the UNIK program. The screws of the screw terminal must be tightened with a slotted screwdriver (blade thickness 1 mm) to the stop with a torque of $3,5 \pm 0,5$ N·m (for transformer-operated meters, the force should be no more than $2,5 \pm 0,5$).

6. Fasten the terminal cover with the help of screws up to the stop with a torque of $0,5 \pm 0,1$ N·m, and perform sealing.

7. Apply voltage to the meter, and make sure that the indication on the LCD shows the regular operation of the meter described in section "2.6. Description of the windows displayed on the screen", otherwise the connection should be corrected or the meter replaced.


When connecting the meter to the electrical network, the types of conductors should be used are rigid, rigid multi-core or flexible multi-core. Conductor material is copper or aluminum. When connecting the meter to the electrical network with an aluminum wire, the specified wires must be pressed into special sleeves that prevent corrosion of the connections in the meter terminal.

The diameter of the cross-section is selected depending on the maximum current passing through the conductor (from 3 to 6 mm).

2.2. Procedure for replacing the backup battery

A back-up battery is used to power the meter clock. Only the energy supplier or an authorized organization has the right to replace the battery.

Procedure for replacing the power battery:

1. Cut off the seal of the optical port cover, unscrew the sealing screw;
2. Open the cover of the optoport;
3. Pull out the case with the battery;
4. Pull out and disconnect the old power battery and install and connect the new one observing the polarity.
5. Install the case with the battery back into the meter. If the LCD continues to display the symbol  (see "Figure 2. Appearance of the LCD") after replacing the power battery then the installed battery is discharged or the battery was installed incorrectly in terms of polarity;
6. Set the current date and time in the meter through the optoport or other available interface;
7. Close the cover of the optoport on the meter, tighten the sealing screw and apply the seal.

To save the date and time settings, before replacing the battery, it is recommended to connect the meter to the Auxiliary Power Supply (installed additionally by agreement with the customer). The connection diagram of the Auxiliary Power Supply and its recommended voltage rate is given in the appendix "Appendix B Connection diagrams of the meter".

2.3. Types of conductors for connecting meters

Conductor types: rigid, rigid stranded or flexible stranded.

Conductor material: copper or aluminum.

The diameter of the cross-section is selected depending on the maximum current passing through the conductor (from 3 to 6 mm).

2.4. Use of meters

In the operating mode, the meter measures active and reactive electric energy, in the forward and reverse direction with a cumulative total (depending on the version according to the table of versions).

Optical pulse test outputs are installed in the meters, which are also used as LED indicators of functioning when measuring active and reactive energy. Through special holes in the nameplate, they are brought out under the cover of the meter. When the load is connected to the measured circuit, the optical pulse test outputs blink with a frequency proportional to the power consumption and switch synchronously with the electrical test pulse outputs.

Electrical test pulse outputs are implemented on electronic keys with optical separation. The maximum permissible voltage of the key in the open state is not less than 30 V, the maximum permissible current of the key in the closed state is not less than 30 mA.

2.5. Reading data

Information from meters can be read:

- visually, from an electronic display;
- through any interface installed in the meter.

2.5.1. Options for reading data through interfaces

The following options for reading data through interfaces are provided:

- through RS-485 electrical interfaces;
- through the 4G/LTE interface (if available);
- through an optical communication interface (optoport).

For a description of the interfaces, see clause 1.10. Optical head OP200 (Optical-Probe or analogue) and software are used for connection via the optical communication interface.

2.5.2. Exchange functionality through the interface

By connecting to the meter, you can:

- read or change the rate model of the meter;
- read the load profile of each type of measured energy;
- read the value of each type of energy for each rate, and in total for all rates for the last day or month;
- read event log;
- adjust the clock and calendar;
- to read the value of all values measured by the meter;
- read or change settings of interfaces, parameters of indication thresholds, information about the place of installation of the meter;
- change the access password;
- enable or disable the sound signal of the meter, which appears when the buttons are pressed;
- change the rate number or the time intervals of the switch output;

- change the number and order of displaying windows on the LCD.

2.5.3. Exchange via optoport

Data reading via optical communication interface is accomplished according to EN 62056-21.

The meter implements data reading without authorization through an optical communication interface in accordance with EN 62056-21 (MODE-C). OBIS codes and their values, which are read from the meter in MODE-C mode without authorization, are given in Appendix D.

2.5.4. Display of total energy and total power.

Meters calculate the value of each type of energy with accuracy to the third decimal place, and the LCD displays values with accuracy to the second decimal place, therefore:

- the value of each type of total energy for all rates, which is displayed on the LCD of the meter ($W_{\Sigma LCD}$), can be greater than the value of the total energy $W_{\Sigma V}$ calculated by formula (1) by no more than 0,004 kW (2).

$$W_{\Sigma V} = W_1 + W_2 + W_3 + W_4 \quad (1)$$

$$W_{\Sigma LCD} - W_{\Sigma V} \leq 0,004 \text{ kW} \quad (2)$$

where W_1, W_2, W_3, W_4 are energy values displayed on the LCD of the meter according to the first, second, third and fourth rates, respectively.

- the value of each type of energy for a certain period W_n , subtracted from the meter using the parameterization program, can be more than the sum of energy values of 30-minute intervals $W_{\Sigma 30}$, subtracted from the meter using the parameterization program for the same period, by more than 0,048 kW (3).

$$W_n - W_{\Sigma 30} \leq 0,048 \text{ kW} \quad (3)$$

2.6. Description of the windows displayed on the screen

The liquid crystal indicator, the purpose of its symbols and groups of symbols are described in detail in section "1.8.4 Data display".

2.6.1. The order of windows displaying

After supplying power to the meter, windows with data and the corresponding OBIS code are formed in the memory in a sequential order. The order of the windows depends on the meter settings. When the meter is turned on, all LCD segments light up. In the automatic mode of the menu, the information on the LCD changes every 10 seconds. The type of data in the window is specified when parameterizing the meters. A table with a complete list of OBIS codes is provided in 0

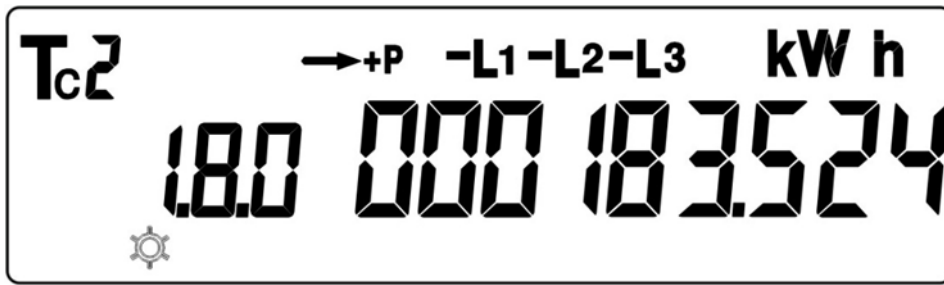


Figure 7. Example of the displayed window

Figure 7 shows an example of one of the possible meter windows. In the table "Table D.1. List of OBIS codes that can be displayed on the screen" (see " Appendix D. Table of OBIS codes that can be displayed on the screen") you can find out that the active OBIS code "1.8.0" is displayed in this window corresponds to total active energy (A +) for all rates. The symbol "Tc2" means that the meter is currently accumulating energy at the second rate. Constant display of symbols "L1", "L2", "L3" means that the voltage values on the first, second and third phases are within the set limits.

2.6.2. Manual viewing of windows

The manual data review function makes it possible to use the mechanical buttons 4 and 5 (see Figure 1) to display most of the saved data on the LCD. The algorithm for switching the LCD windows in the meters is shown in Figure 8.

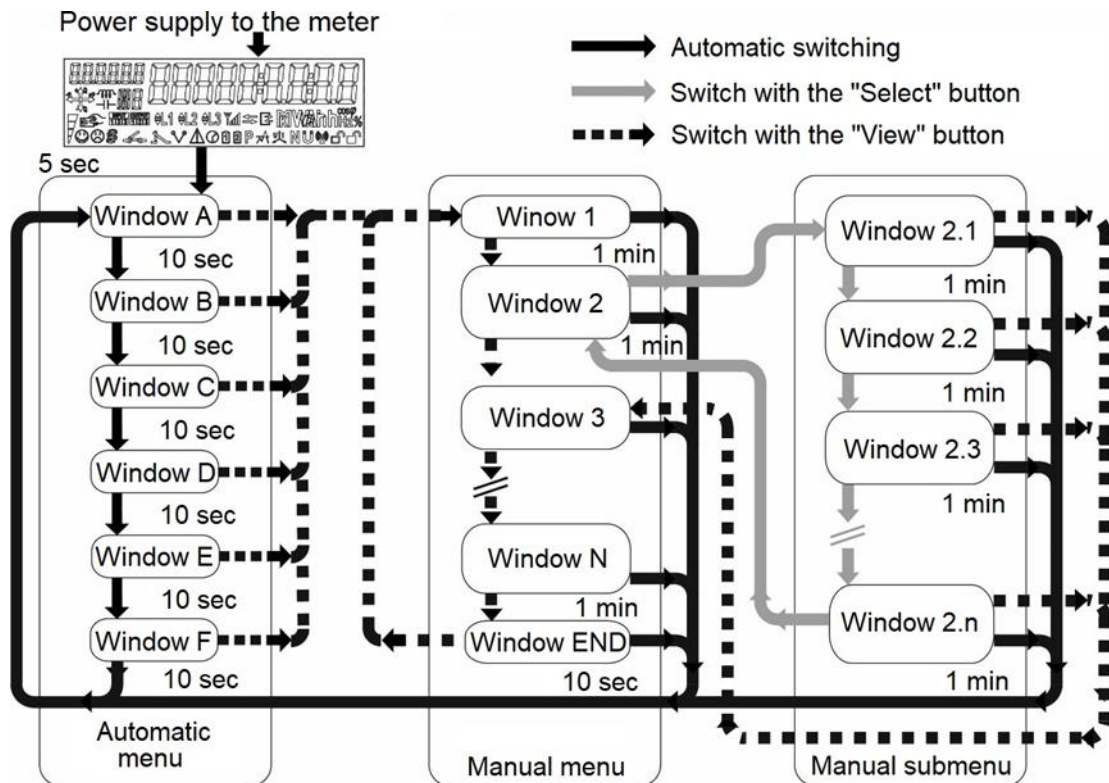


Figure 8. Window switching algorithm

The list of possible LCD windows and the order of their output is set when parameterizing the meters. Each time you click the "View" button, the measured values with the corresponding OBIS code and

units of measurement are displayed in the windows. When you press the "Select" button, you enter and switch windows within the submenu.

2.6.3. Indication of various modes of operation of meters

If one or more symbols "L1", "L2", "L3" flash synchronously in the window during the indication of energy measurement, the voltage in the corresponding phase has exceeded the set thresholds. The corresponding indicator blinks with a frequency of 0,5 Hz if the voltage is low, and with a frequency of 2 Hz if it is high.

The reverse direction of energy is displayed in the form of "-" signs in front of the "L1", "L2", "L3" indicators.

If the symbols "L1", "L2", "L3" alternately flash and go out in the window during the energy indication, the meters are not correctly connected to the network (incorrect phase sequence).

If the symbol "▲" is displayed on the LCD (see Figure.2) there are errors in the meter, sensors (magnetic field sensor or electromagnetic field sensor) have been activated or debt information has been recorded.

If the symbol "🔒" is displayed on the LCD (see Figure 2), the cover of the meter is open. If the meter is sealed and the sealing screws are tightened all the way, and the symbol "🔒" appears, then the meter should be sent for repair.

If the symbol "🔓" is displayed on the LCD (see Figure.2), the terminal cover is open in the meter. If at the same time the terminal cover is installed and the sealing screws are tightened to the stop, the meter should be sent for repair.

If the symbol "🔋" is displayed on the LCD (see Figure.2) - the power supply battery of the meter clock requires replacement. The procedure for replacing the power battery is described in section "2.2. The procedure for replacing the backup battery".

2.6.4. Indication of error codes

If a failure occurred during the operation of the meter, then a window with an error and its code is displayed on the LCD. Possible failures include the opening of the terminal cover or the meter cover, the effect of a magnet or a radio field, over or under voltage. The error code consists of three characters. An example of the window is shown in Figure 9.



Figure 9. Meter failure window

All error codes are given in the appendix "Appendix D. "Error codes".

2.6.5. Examples of displayed windows

The order of displayed windows on the LCD screen depends on parameterization. Each displayed OBIS-code corresponds to a measured value. The meaning of each of the possible OBIS codes is given in the appendix "Table of OBIS codes that can be displayed on the screen". By successively pressing the "View" button, you should select the OBIS code of the corresponding measured value, the value of which must be visually read. The "Select" button is pressed when it is necessary to display the value of the measured value on the screen separately for one specific rate or phase.

Examples of windows displaying active energy (A+) in total by phases and by rates, and separately in phase L2 are shown in Figure 10 and Figure 11 respectively.

Display of values and measurement units of active energy (A-), reactive energy (R+), reactive energy (R-) is similar.

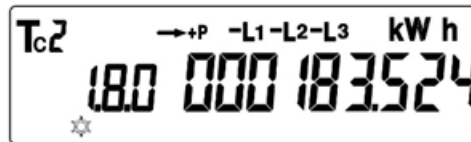


Figure 10. Active energy (A+) in total by phases and rates

The possibility of measuring each of these values with a meter, depending on the version of the meter, can be determined with Table.3 and Table.4.

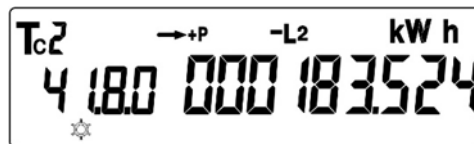


Figure 11. Active energy (A+) in phase L2

The meter can display the current time of the meter clock, the current date, and the serial number of the meter. When selecting the desired code (see the table of OBIS codes in the appendix "0"), the appropriate parameter will be displayed on the right side of the screen. Examples of displaying the current time and date are shown in Figure.12 and Figure.13.

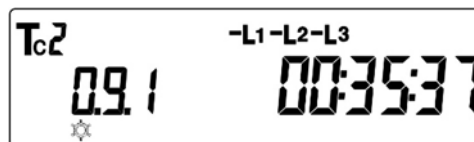


Figure 12. The window for displaying the current clock time

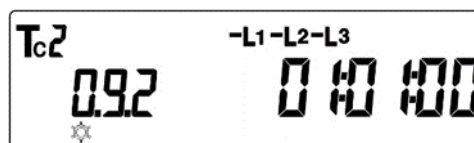


Figure 13. The window for displaying the current clock date of 01.01.2000

The meter can display the value of the module of active energy ($|A_{+}|+|A_{-}|$) on the screen for all phases and rates. An example of the display window is shown in Figure 14.

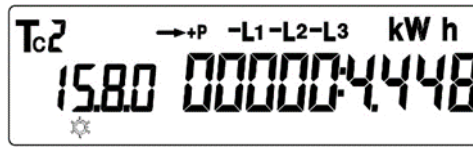


Figure 14. Display window of the value of the module of active energy

3 Maintenance

3.1. General instructions

The periodicity of maintenance for meters under compliance with operating conditions is provided in the table 5.

Maintenance consists of the operation of verification or repairing and calibrating the meter.

The verification operation is carried out by an authorized body.

The repair and calibration operation are carried out at the manufacturer's factory.

3.2. Instructions for safety measures

According to the method of protecting people from electric shock, the meters correspond to class II according to EN 61140.

Isolation between all circuits of current, voltage, "ground" on one side and terminals of interfaces and test outputs on the other withstands a test voltage of 4 kV (rms value) with a frequency of (50-2,5) Hz for 1 minute.

The insulation resistance between the case and electric circuits is not less than:

- 20 MΩ - under normal conditions;
- 7 MΩ - at ambient air temperature (30±2)°C and relative air humidity of 90%.

4 Transportation and storage

4.1. Requirements for transportation of the product and storage of meters

The conditions of transportation and storage of meters in the transport container of the manufacturer correspond to the conditions described in section "1.6 Requirements for operating conditions".

Meters can be transported in covered railway cars, transported by road transport with protection from rain and snow, by water transport, and also transported in sealed heating compartments of airplanes.

Transportation must be carried out in accordance with the rules of transportation that apply to each type of transport.

Meters in a transport container are resistant to the influence of the ambient air temperature from minus 40°C to plus 70°C, the influence of the relative humidity of the ambient air up to 95% at a temperature of 30°C and atmospheric pressure from 70 to 106.7 kPa (from 537 to 800 mm Hg.).

Meters in a transport container are resistant to the impact of transport shaking with the number of impacts from 80 to 120 per minute with an acceleration of 30 m/s².

5 Requirements for environmental protection and disposal of the device

After the end of its service life, the device must not be thrown away with household waste. Disposal must be carried out in compliance with all current requirements of the local legislation.

In order to prevent possible damage to the environment due to uncontrolled waste disposal, please separate this product from other waste and reuse it or its components.

6 Manufacturer's warranty

The manufacturer guarantees the compliance of the meters with the requirements of EN 62052-11, EN 62053-21, EN 62053-22, EN 62053-23, EN 50470-1, EN 50470-3 if the consumer observes the conditions of installation, operation, transportation and storage.

Before operating the meters, you must read the operations manual included in the delivery kit or posted on the official website - see Table 11.

The warranty period (the period of operation and the period of storage in total) is 3 years from the date of sale.

Meters found to be non-compliant with the requirements of technical conditions and a valid passport during the warranty period must be replaced or repaired by the manufacturer or an enterprise authorized to carry out warranty repairs.

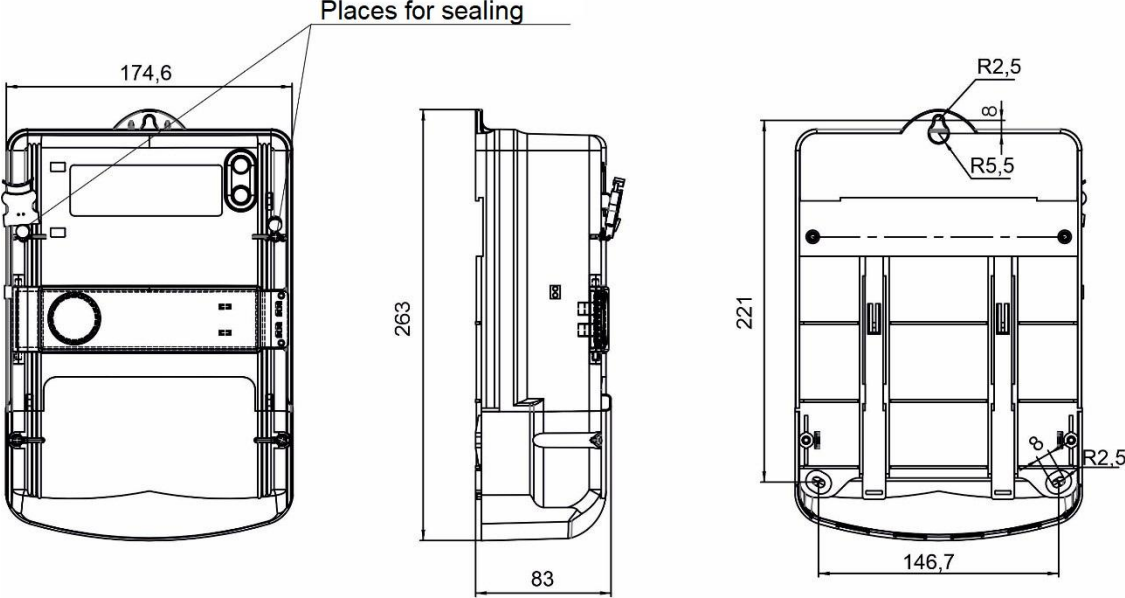
The warranty period of meters is extended for the time calculated from the moment of application by the consumer until the defect is eliminated by the manufacturer. At the end of the warranty period, during the service life of the meters, repairs are carried out by the manufacturer or service organizations. In this case, the repair is carried out at the expense of the consumer.

Meters that were transported, stored, installed and used in violation of the requirements specified in the operations manual and meters that have damage to the case, base, screw terminal or the consequences of their thermal heating, a damaged seal of the manufacturer, and also if the product has signs of mechanical damages received as a result of any actions of the buyer or third parties are not subject to warranty repair.

The manufacturer's warranty do not extend to external backup batteries.

Please notify the manufacturer of "NIK-ELEKTRONIKA" LLC about detected deficiencies of the meters.

Appendix A. Overall and installation dimensions of the meter



Dimensions for reference

Figure A 1. Overall and installation dimensions of meters

Appendix B. Connection diagrams of the meter

Figure B.1 shows the connection diagram of the interfaces and electrical pulse test outputs of the direct connected meters.

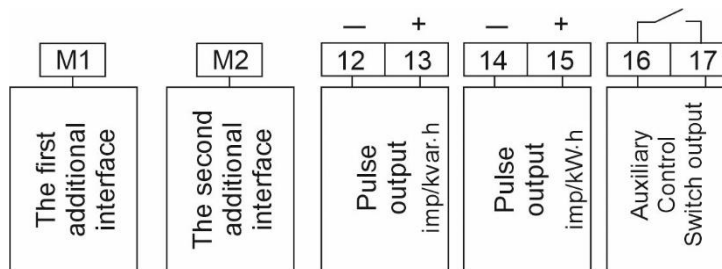


Figure B.1. Connection diagram of the interfaces and electrical pulse test outputs of the direct connected meter.

Figure B.2 shows the connection diagram of the interfaces and electrical pulse test outputs of the transformer operated meter.

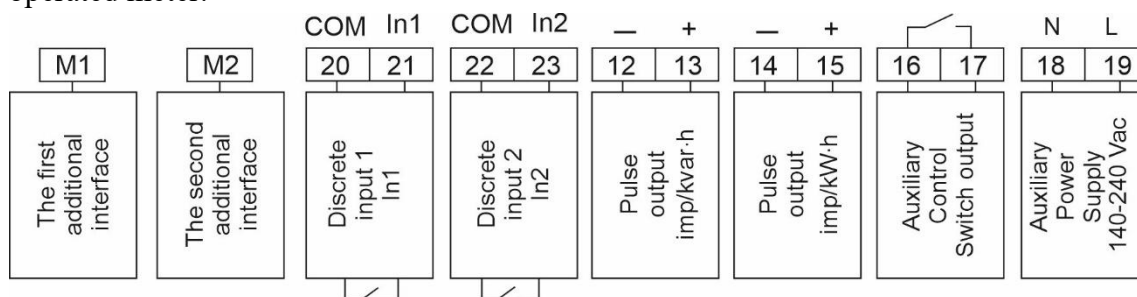


Figure B.2. Connection diagram of the interfaces and electrical impulse test outputs of the transformer operated meter.

Depending on the version of the meter, connectors M1, M2 and terminals 12, 13, 16...17 may not be installed or may not be used.

The SMA type connector for connecting the LTE antenna may be installed instead of the M1 connector in the versions of the meters with the 4G/LTE interface.

Figure B.3 shows the pin numbering of the connection connector to the RS-485 interface for direct connected meters.

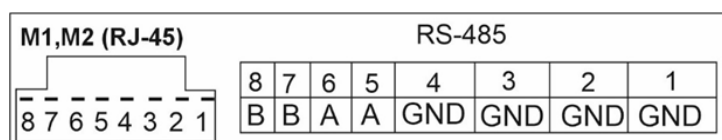


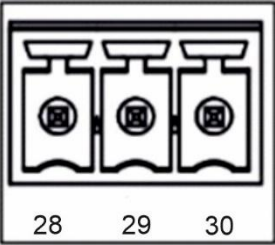
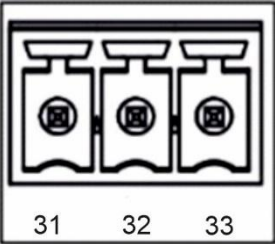
Figure B.3. Pin numbering of RJ-45 connectors of the first and second additional interfaces for direct connected meters

Pulse outputs In1 and In2 do not have a galvanic separation between them.

Table B.1. shows the pin numbering of the connection connector to the RS-485 interface for transformer operated meters.

Table B.1. Pin numbering of the connection connector to the RS-485 interface for transformer operated meters.

M1	Name
	28 – RS-485 GND
	29 – RS-485 A

	<p>30– RS-485 B</p>
<p>M2</p>	<p>Name</p>
	<p>31 – RS-485 GND 32 – RS-485 A 33– RS-485 B</p>

Appendix C. Meters connection diagrams to networks and consumers

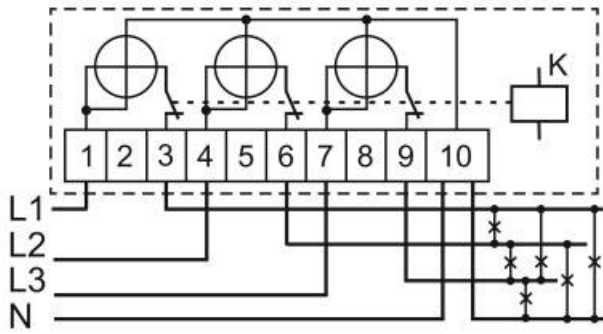


Figure B.1. Connection of NIK 2308 direct connected meters

Note: the availability of the K switch depends on the version of the meter.

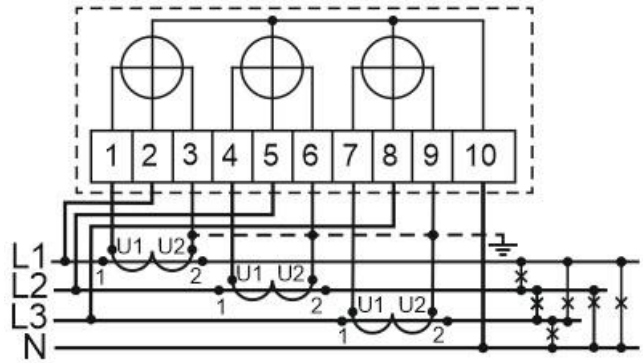


Figure B.2. Connection of NIK 2308 transformer operated meters with a nominal voltage of 3x220/380 V, 3x230/400 V, 3x240/416 V or with a wide voltage range of 3x57,7...240/100...416 V

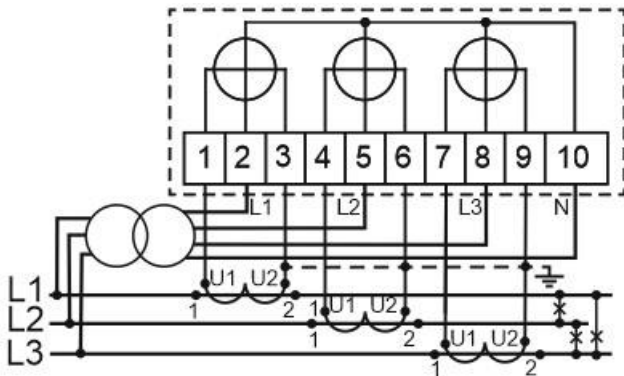


Figure B.3. Connection of NIK 2308 transformer operated meters with nominal voltage 3x57,7/100 V

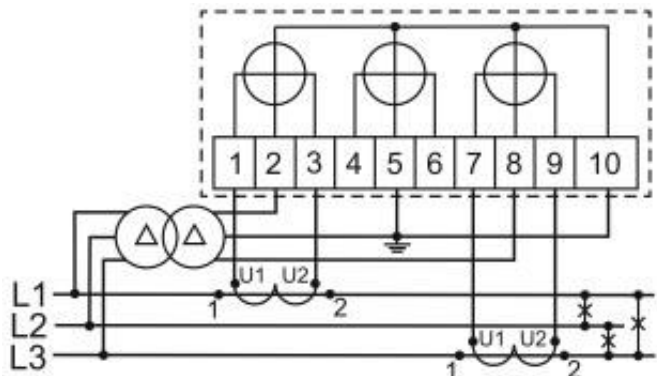


Figure B.4. Connection of NIK 2308 transformer operated meters with a nominal voltage of 3x57,7/100 V or a wide range nominal voltage 3x57,7...240/100...416 V to the network according to the triangle scheme

Appendix D. Table of OBIS codes that can be displayed on the screen

Table D.1. List of OBIS codes that can be displayed on the screen (the number of codes depends on the meter version)

No	Measured values	OBIS code
1.	Indication of the current time of the meter hours in the format "hours: minutes: seconds"	0.9.1
2.	Indication of the current date of the meter hours in the "day - month - year" format	0.9.2
3.	Indication of the unique serial number of the meter	96.1.0
4.	Meter type indication	96.1.1
5.	Indication of the software version	96.1.10
6.	Display of software checksum	96.1.11
7.	Current transformation coefficient	0.4.2
8.	Voltage transformation coefficient	0.4.3
9.	Active energy (1 + 4 quadrant), kWh on (6 + 3) LCD	1.8.0
10.	Active energy (1 + 4 quadrant) phase L1, kW·h	21.8.0
11.	Active energy (1 + 4 quadrant) phase L2, kW·h	41.8.0
12.	Active energy (1 + 4 quadrant) phase L3, kW·h	61.8.0
13.	Active energy at the nth rate, kW·h (n - from 1 to 4)	1.8.n (1.8.1-1.8.4)
14.	Active energy (2 + 3 quadrant), kW·h	2.8.0
15.	Active energy (2 + 3 quadrant) phase L1, kW·h	22.8.0
16.	Active energy (2 + 3 quadrant) phase L2, kW·h	42.8.0
17.	Active energy (2 + 3 quadrant) phase L3, kW·h	62.8.0
18.	Active energy at the nth rate, kW·h (n - from 1 to 4)	2.8.n (2.8.1-2.8.4)
19.	Reactive energy (1 + 2 quadrant), kvar·h	3.8.0
20.	Reactive energy (1 + 2 quadrant) phase L1, kvar·h	23.8.0
21.	Reactive energy (1 + 2 quadrant) phase L2, kvar·h	43.8.0
22.	Reactive energy (1 + 2 quadrant) phase L3, kvar·h	63.8.0
23.	Reactive energy (1 + 2 quadrant) at the nth rate, kvar·h (n - from 1 to 4)	3.8.n (3.8.1-3.8.4)
24.	Reactive energy (3 + 4 quadrant), kvar·h	4.8.0
25.	Reactive energy (3 + 4 quadrant) phase L1, kvar·h	24.8.0
26.	Reactive energy (3 + 4 quadrant) phase L2, kvar·h	44.8.0
27.	Reactive energy (3 + 4 quadrant) phase L3, kvar·h	64.8.0
28.	Reactive energy (quadrant 3 + 4) according to the nth rate, kvar·h (n - from 1 to 4)	4.8.n (4.8.1-4.8.4)
29.	Reactive energy (1 quadrant) for A +, kvar·h	5.8.0
30.	Reactive energy (1 quadrant) for A + phase L1, kvar·h	25.8.0
31.	Reactive energy (1 quadrant) for A + phase L2, kvar·h	45.8.0
32.	Reactive energy (1 quadrant) for A + phase L3, kvar·h	65.8.0
33.	Reactive energy (1 quadrant) for A + at the nth rate, kvar·h (n - from 1 to 4)	5.8.n (5.8.1-5.8.4)
34.	Reactive energy (2nd quadrant) for A-, kvar·h	6.8.0
35.	Reactive energy (2nd quadrant) for A-phase L1, kvar·h	26.8.0
36.	Reactive energy (2nd quadrant) for A-phase L2, kvar·h	46.8.0
37.	Reactive energy (2nd quadrant) for A-phase L3, kvar·h	66.8.0

No	Measured values	OBIS code
38.	Reactive energy (quadrant 2) for A- at the nth rate, kvar·h (n - from 1 to 4)	6.8.n (6.8.1-6.8.4)
39.	Reactive energy (3rd quadrant) for A-, kvar·h	7.8.0
40.	Reactive energy (3rd quadrant) for A-phase L1, kvar·h	27.8.0
41.	Reactive energy (3rd quadrant) for A-phase L2, kvar·h	47.8.0
42.	Reactive energy (3rd quadrant) for A-phase L3, kvar·h	67.8.0
43.	Reactive energy (3rd quadrant) for A- at the nth rate, kvar·h (n - from 1 to 4)	7.8.n (7.8.1-7.8.4)
44.	Reactive energy (4th quadrant) for A +, kvar·h	8.8.0
45.	Reactive energy (4th quadrant) for A + phase L1, kvar·h	28.8.0
46.	Reactive energy (4th quadrant) for A + phase L2, kvar·h	48.8.0
47.	Reactive energy (4th quadrant) for A + phase L3, kvar·h	68.8.0
48.	Reactive energy (4th quadrant) for A + at the nth rate, kvar·h (n - from 1 to 4)	8.8.n (8.8.1-8.8.4)
49.	Full energy S+ (1 +4 quadrants), kVA·h	9.8.0
50.	Full energy S+ (1 +4 quadrants) phase L1, kVA·h	29.8.0
51.	Full energy S+ (1 +4 quadrants) phase L2, kVA·h	49.8.0
52.	Full energy S+ (1 +4 quadrants) phase L3, kVA·h	69.8.0
53.	Full energy S- (2 +3 quadrants), kVA·h	10.8.0
54.	Full energy S- (2 +3 quadrants) phase L1, kVA·h	30.8.0
55.	Full energy S- (2 +3 quadrants) phase L2, kVA·h	50.8.0
56.	Full energy S- (2 +3 quadrants) phase L3, kVA·h	70.8.0
57.	Active energy A+ + A- , kW·h	15.8.0
58.	Active energy A+ + A- phase L1, kW·h	35.8.0
59.	Active energy A+ + A- phase L2, kW·h	55.8.0
60.	Active energy A+ + A- phase L3, kW·h	75.8.0
61.	Active energy A+ + A- at the nth rate, kW·h (n - from 1 to 4)	15.8.n (15.8.1-15.8.4)
62.	Active energy A+ - A- , kW·h	16.8.0
63.	Active energy A+ - A-) phase L1, kW·h	36.8.0
64.	Active energy A+ - A-) phase L2, kW·h	56.8.0
65.	Active energy A+ - A-) phase L3, kW·h	76.8.0
66.	Active energy A+ - A- at the nth rate, kW·h	16.8.n (16.8.1-16.8.4)
67.	Active energy (1 quadrant), kW·h	17.8.0
68.	Active energy (1 quadrant) of phase L1, kW·h	37.8.0
69.	Active energy (1 quadrant) of phase L1, kW·h	57.8.0
70.	Active energy (1 quadrant) of phase L1, kW·h	77.8.0
71.	Active energy (2nd quadrant), kW·h	18.8.0
72.	Active energy (2nd quadrant) of phase L1, kW·h	38.8.0
73.	Active energy (2nd quadrant) of phase L1, kW·h	58.8.0
74.	Active energy (2nd quadrant) of phase L1, kW·h	78.8.0
75.	Active energy (3rd quadrant), kW·h	19.8.0
76.	Active energy (3rd quadrant) of phase L1, kW·h	39.8.0
77.	Active energy (3rd quadrant) of phase L1, kW·h	59.8.0
78.	Active energy (3rd quadrant) of phase L1, kW·h	79.8.0
79.	Active energy (4th quadrant), kW·h	20.8.0

No	Measured values	OBIS code
80.	Active energy (4th quadrant) of phase L1, kW·h	40.8.0
81.	Active energy (4th quadrant) of phase L1, kW·h	60.8.0
82.	Active energy (4th quadrant) of phase L1, kW·h	80.8.0
83.	Instantaneous active power (1+4 quadrants), kW	1.7.0
84.	Instantaneous active power (1+4 quadrants) of phase L1, kW	21.7.0
85.	Instantaneous active power (1+4 quadrants) of phase L2, kW	41.7.0
86.	Instantaneous active power (1+4 quadrants) of phase L3, kW	61.7.0
87.	Instantaneous active power (2+3 quadrants), kW	2.7.0
88.	Instantaneous active power (2+3 quadrants) of phase L1, kW	22.7.0
89.	Instantaneous active power (2+3 quadrants) of phase L2, kW	42.7.0
90.	Instantaneous active power (2+3 quadrants) of phase L3, kW	62.7.0
91.	Instantaneous reactive power (1+2 quadrants), kvar	3.7.0
92.	Instantaneous reactive power (1+2 quadrants) of phase L1, kvar	23.7.0
93.	Instantaneous reactive power (1+2 quadrants) of phase L2, kvar	43.7.0
94.	Instantaneous reactive power (1+2 quadrants) of phase L3, kvar	63.7.0
95.	Instantaneous reactive power (3+4 quadrants), kvar	4.7.0
96.	Instantaneous reactive power (3+4 quadrants) of phase L1, kvar	24.7.0
97.	Instantaneous reactive power (3+4 quadrants) of phase L2, kvar	44.7.0
98.	Instantaneous reactive power (3+4 quadrants) of phase L3, kvar	64.7.0
99.	Instantaneous reactive power in the nth quadrant, kvar	n.7.0 (5.7.0-8.7.0)
100.	Instantaneous reactive power in the nth quadrant of phase L1, kvar	n.7.0 (25.7.0-28.7.0)
101.	Instantaneous reactive power in the nth quadrant of phase L2, kvar	n.7.0 (45.7.0-48.7.0)
102.	Instantaneous reactive power in the nth quadrant of phase L3, kvar	n.7.0 (65.7.0-68.7.0)
103.	Instantaneous full power S+ (1+4 quadrants), kVA	9.7.0
104.	Instantaneous full power S+ (1+4 quadrants) phase L1, kVA	29.7.0
105.	Instantaneous full power S+ (1+4 quadrants) phase L2, kVA	49.7.0
106.	Instantaneous full power S+ (1+4 quadrants) phase L3, kVA	69.7.0
107.	Instantaneous full power S- (2+3 quadrants), kVA	10.7.0
108.	Instantaneous full power of S- (2+3 quadrants) phase L1, kVA	30.7.0
109.	Instantaneous full power of S- (2+3 quadrants) phase L2, kVA	50.7.0
110.	Instantaneous total power of S- (2+3 quadrants) phase L3, kVA	70.7.0
111.	Instantaneous active power A+ + A-), kW	15.7.0
112.	Instantaneous active power A+ + A-) phase L1, kW	35.7.0
113.	Instantaneous active power A+ + A-) phase L2, kW	55.7.0
114.	Instantaneous active power A+ + A-) phase L3, kW	75.7.0
115.	Instantaneous active power A+ - A-), kW	16.7.0
116.	Instantaneous active power A+ - A-) phase L1, kW	36.7.0
117.	Instantaneous active power A+ - A-) phase L2, kW	56.7.0
118.	Instantaneous active power A+ - A-) phase L3, kW	76.7.0
119.	Instantaneous active power in the nth quadrant, kW	n.7.0 (17.7.0-20.7.0)
120.	Instantaneous active power in the nth quadrant of phase L1, kW	n.7.0 (37.7.0-40.7.0)

No	Measured values	OBIS code
121.	Instantaneous active power in the nth quadrant of phase L2, kW	n.7.0 (57.7.0-60.7.0)
122.	Instantaneous active power in the nth quadrant of phase L3, kW	n.7.0 (77.7.0-80.7.0)
123.	Current strength of phase L1, A	31.7.0
124.	Current strength of phase L2, A	51.7.0
125.	Current strength of phase L3, A	71.7.0
126.	Voltage of phase L1, V	32.7.0
127.	Voltage of phase L2, V	52.7.0
128.	Voltage of phase L3, V	72.7.0
129.	Power factor of phase L1	33.7.0
130.	Power factor of phase L2	53.7.0
131.	Power factor of phase L3	73.7.0
132.	The value of the frequency of the main harmonic of phase L1, Hz	34.7.0
133.	The value of the frequency of the main harmonic of phase L2, Hz	54.7.0
134.	The value of the frequency of the main harmonic of phase L3, Hz	74.7.0
135.	Angle between phases L1 and L2	81.7.10
136.	Angle between phases L1 and L3	81.7.20




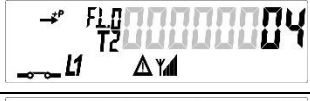
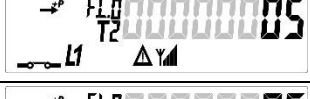
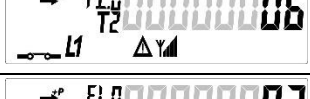





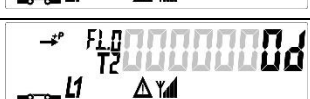
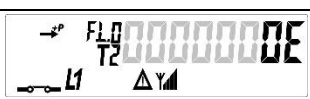
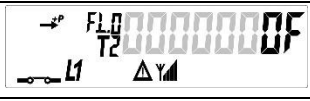
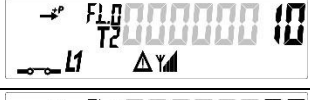


Appendix E. Error codes


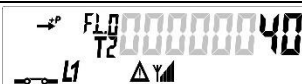

















Table E.1. Meter error codes


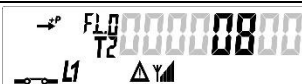











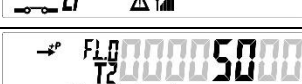





Error code	Value	Action
Err 006	Real time clock failure	Check whether the backup battery has failed. Set the clock through the optohead or one of the interfaces. Check whether the parameterization of the rate grid is performed correctly
Err 016	Internal system failure	Contact the energy supply organization and service center
Err 040	The terminal cover of the meter is open	Install the terminal cover of the meter, or tighten the sealing screw of the terminal cover more tightly
Err 044	The cover of the meter case is open	Contact the energy supply organization and service center
Err 051	Internal system failure	Contact the energy supply organization and service center
Err 090	Current inequality in phase and neutral circuits	Check the connection diagram of the meter
Err 091	Reverse current (does not occur in meter versions that measure active electrical energy in forward and reverse directions)	Check the meter connection diagram
Err 200	Internal system failure	Contact the energy supply organization and service center
Err 201	Internal system failure	Contact the energy supply organization and service center
Err 205	Internal system failure	Contact the energy supply organization and service center
Err 206	Internal system failure	Contact the energy supply organization and service center
Err 230	Internal system failure	Contact the energy supply organization and service center
Err 231	Internal system failure	Contact the energy supply organization and service center
Err 232	Parameterization error	Check whether the parameterization of the rate grid is performed correctly
Err 237	Internal system failure	Contact the energy supply organization and service center
rAd, 0	The electromagnetic field sensor was triggered	Contact the energy supply organization


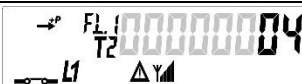




ПРАГМ	The magnetic field sensor was triggered	Contact the energy supply organization
--------------	---	--

Table E.2. Indication of error codes

Crash register 1 (OBIS-code 0.0.97.98.0.255)		
Value	Description	
00 00 00 01	Time value was lost	
00 00 00 02	Low battery	
00 00 00 03	Time value was lost + Low battery	
00 00 00 04	Terminal cover is open	
00 00 00 05	Low battery	
00 00 00 06	Terminal cover is open + Low battery	
00 00 00 07	Terminal cover is open + Low battery + Time value was lost	
00 00 00 08	The meter cover is open	
00 00 00 09	The meter cover is open + Time value was lost	
00 00 00 0A	The meter cover is open + Low battery	
00 00 00 0B	The meter cover is open + Low battery + Time value was lost	
00 00 00 0C	The meter cover is open + Terminal cover is open	
00 00 00 0D	The meter cover is open + Terminal cover is open + Time value was lost	
00 00 00 0E	The meter cover is open + Terminal cover is open + Low battery	
00 00 00 0F	The meter cover is open + Terminal cover is open + Low battery + Time value was lost	
00 00 00 10	Activation of the magnetic field sensor	
00 00 00 20	Association authentication error	

00 00 00 30	Association authentication error + Activation of the magnetic field sensor	
00 00 00 40	Decryption authentication failed	
00 00 00 50	Decryption authentication failed + Activation of the magnetic field sensor	
00 00 00 60	Decryption authentication failed + Association authentication error	
00 00 00 70	Decryption authentication failed + Association authentication error + Activation of the magnetic field sensor	
00 00 00 80	Repeat of the attack	
00 00 00 90	Repeat of the attack + Activation of the magnetic field sensor	
00 00 00 A0	Repeat of the attack + Association authentication error	
00 00 00 B0	Repeat of the attack + Association authentication error + Activation of the magnetic field sensor	
00 00 00 C0	Repeat of the attack + Decryption authentication failed	
00 00 00 D0	Repeat of the attack + Decryption authentication failed + Activation of the magnetic field sensor	
00 00 00 E0	Repeat of the attack + Decryption authentication failed + Association authentication error	
00 00 00 F0	Repeat of the attack + Decryption authentication failed + Association authentication error + Activation of the magnetic field sensor	
00 00 01 00	Error in the program	
00 00 02 00	RAM error	
00 00 03 00	Error in the program + RAM error	
00 00 04 00	Non-volatile memory error	
00 00 05 00	Non-volatile memory error + Error in the program	
00 00 06 00	Non-volatile memory error + RAM error	

00 00 07 00	Non-volatile memory error + Error in the program + RAM error	
00 00 08 00	Measuring system error	
00 00 09 00	Measuring system error + Error in the program	
00 00 0A 00	Measuring system error + RAM error	
00 00 0B 00	Measuring system error + RAM error + Error in the program	
00 00 0C 00	Measuring system error + Non-volatile memory error	
00 00 0D 00	Measuring system error + Non-volatile memory error + Error in the program	
00 00 0E 00	Measuring system error + Non-volatile memory error + RAM error	
00 00 0F 00	Measuring system error + Non-volatile memory error + Error in the program + RAM error	
00 00 10 00	Unexpected device reboot event	
00 00 20 00	Fraud attempt	
00 00 30 00	Fraud attempt + Unexpected device reboot event	
00 00 40 00	Activation of the radio sensor	
00 00 50 00	Activation of the radio sensor + Unexpected device reboot event	
00 00 60 00	Activation of the radio sensor + Fraud attempt	
00 00 70 00	Activation of the radio sensor + Fraud attempt + Unexpected device reboot event	
00 00 20 02	Fraud attempt + Low battery	
Crash register 2 (OBIS-code 0.0.97.98.1.255)		
00 00 00 01	Complete power failure	
00 00 00 02	Power restored	

00 00 00 03	Power restored + Complete power failure	
00 00 00 04	No voltage phase L1	
00 00 00 05	No voltage phase L1 + Complete power failure	
00 00 00 06	No voltage phase L1 + Power restored	
00 00 00 10	No voltage phase L1	
00 00 04 00	Current reversal	

Appendix F. List of events

Table F.1. A list of events that can be registered in the event log of the meter

№	Name of the event	Number
1	Triggering WDT ¹	20
2	Turning on the meter	20
3	Turning off the meter	20
4	Opening the terminal cover ²	20
5	Closing the terminal cover ²	20
6	Opening the meter cover ²	20
7	Closing the meter cover ²	20
8	Setting the clock before the change	20
9	Setting the clock after a change	20
10	The total time of the electromagnetic field effect ²	-
11	The beginning of the effect of the electromagnetic field ²	20
12	The end of the electromagnetic field effect ²	20
13	Resetting the electromagnetic field indication ²	20
14	The total time of the magnetic field effect ²	-
15	The beginning of the effect of the magnetic field ²	20
16	The end of the magnetic field effect ²	20
17	Resetting the magnetic field indication ²	20
18	Loss of voltage on phase L1	15
19	Loss of voltage on phase L2	15
20	Loss of voltage on phase L3	15
21	Undervoltage on phase L1	15
22	Undervoltage on phase L2	15
23	Undervoltage on phase L3	15
24	Overvoltage on phase L1	15
25	Overvoltage on phase L2	15
26	Overvoltage on phase L3	15
27	Restoration of voltage on phase L1	15
28	Restoration of voltage on phase L2	15
29	Restoration of voltage on phase L3	15
30	Supply Control Switch ²	15
31	Backup battery status	15
32	Incorrectly entered password	15
33	Clearing the load profile	15
34	Parameterization (change of rate model)	15

Notes:

¹ WDT is a watchdog timer, a hardware-implemented system freeze control scheme.

² On meter versions with the corresponding sensors and switches.

Appendix G. Scheme of the rate grid of the meter

Figure G.1 shows a simplified configuration and operation scheme of the rate grid of the meter.

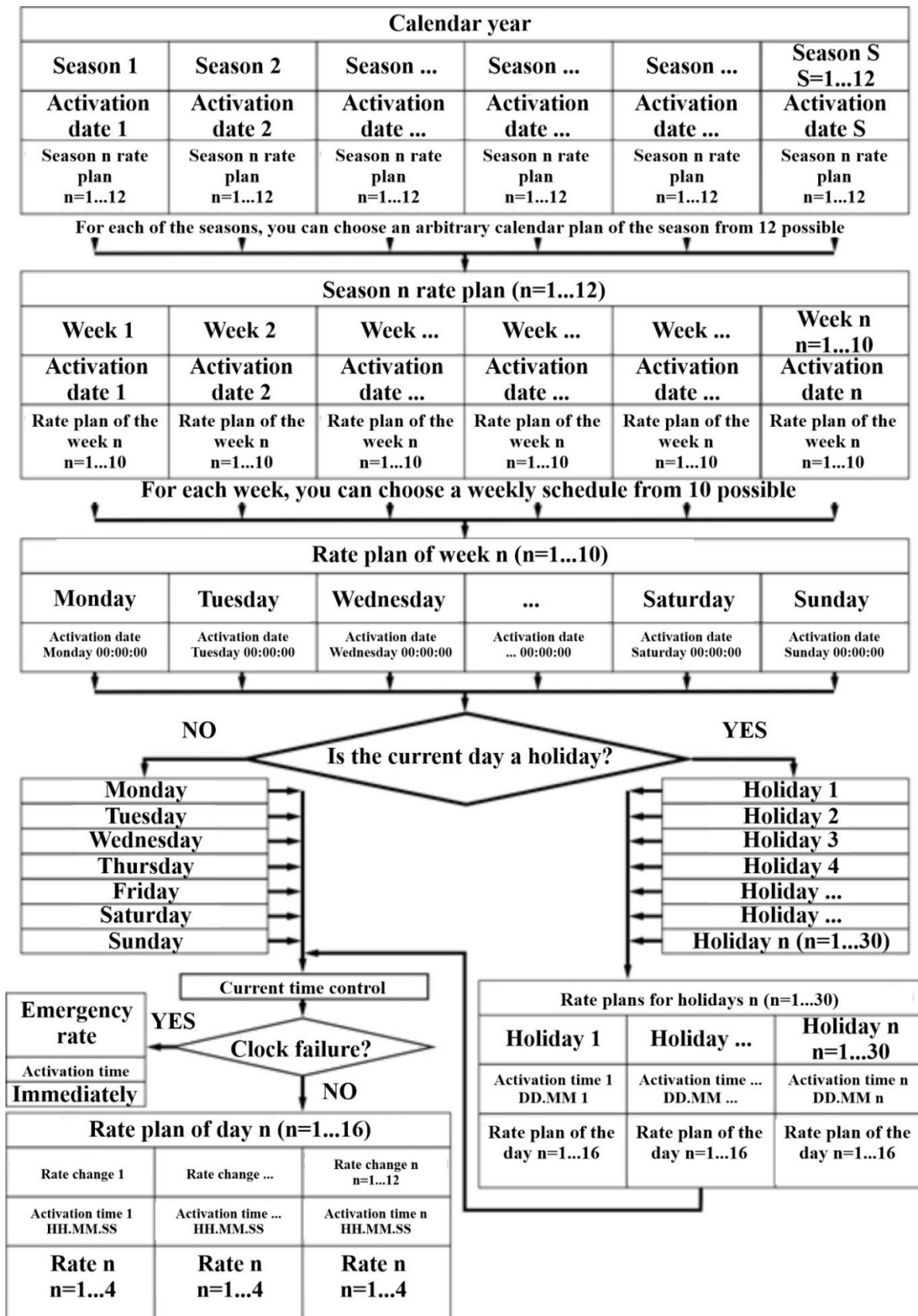


Figure G.1. Simplified scheme of the rate grid