

MUTARIS® PRS





TABLE OF CONTENT

SYSTEM OVERVIEW.....	5
SURGICAL TECHNIQUE.....	8
IMPLANTS.....	18
INSTRUMENTS.....	20
PREOPERATIVE AND POSTOPERATIVE INSTRUCTION.....	29
INDICATIONS AND CONTRAINDICATIONS.....	30
RISKFACORS.....	31

Nota Bene: The author of this technique has outlined the procedure for the uncomplicated surgical scenario. Ultimately however it is the operating surgeon who is best placed to assess and address the individual needs of each patient.

Copyright Information: MUTARS®, implavit® und implatan® Are registered trademarks of implantcast GmbH. The use and/or copying of the content of this brochure, be it wholly or in part, is only allowed with the prior written permission of implantcast GmbH.

PREOPERATIVE PLANNING

Preoperative planning and precise surgical techniques are mandatory for optimal results. The instructions and the procedure given in the surgical technique to the system must be adhered to. Familiarity with the recommended surgical technique and its careful application is essential to achieve the best possible outcome.

Before surgery a surgical planning with regard to the dimensions of the prosthetic model and the positioning of the implant components in the bone has to be carried out by the surgeon.

For this purpose, x-ray templates are available:

Digital templates: Digital templates are included in the data base of the common planning systems. For missing templates, please contact the provider of the planning software and request for these templates.

Radiographic templates: Alternatively, radiographic templates are available in various scale factors, which can be obtained from your local representative.

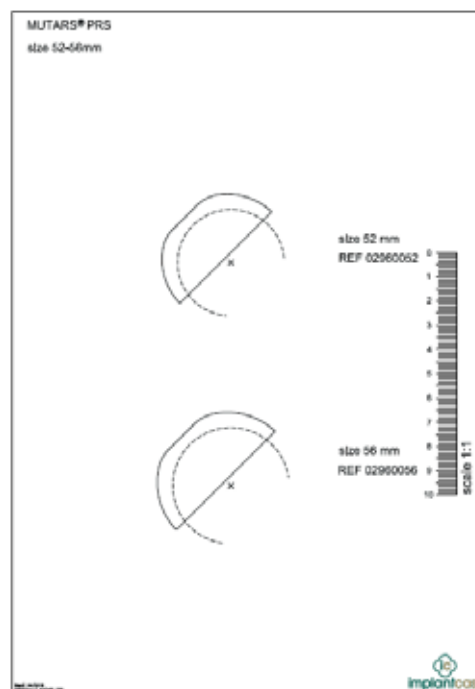

Further, prior to surgery the following should be ensured:

- All needed components are available during surgery. An adequate number of various implant components should be available for surgery. It should be determined whether the implantation should be done with or without the use of bone cement.
- All instruments for the implantation are present and are matching the corresponding implants. The insertion instruments must be adapted to the implant. The implants may only be used with the instruments provided by implantcast GmbH. An exception are exclusively the standardized instruments used during surgery.
- The correct sized instruments are used during surgery to prevent damage to the implants.

For more information, please refer to the instructions for use „metal augments“ (09300087GB) and this surgical technique from page 29.

SYSTEMOVERVIEW

REF	size (outer Ø)	combination (outer Ø)
02960052	52mm	EcoFit® 2M cm. / TiN 44mm
02960056	56mm	EcoFit® 2M cm. / TiN 46 / 48mm
02960060	60mm	EcoFit® 2M cm. / TiN 48 / 50mm
02960064	64mm	EcoFit® 2M cm. / TiN 52 / 54mm
02960068	68mm	EcoFit® 2M cm. / TiN 56 / 58mm
02960072	72mm	EcoFit® 2M cm. / TiN 60 / 62mm



cement mantle: 2mm



REF	size (outer Ø)	combination (outer Ø)
02960052	52mm	Müller II cup 44mm
02960056	56mm	Müller II cup 46 / 48mm
02960060	60mm	Müller II cup 48 / 50mm
02960064	64mm	Müller II cup 52 / 54mm
02960068	68mm	Müller II cup 56 / 58mm
02960072	72mm	Müller II cup 60 / 62mm

DESIGN FEATURES

indication:
acetabular defects acc. to Paprosky till Type 3a

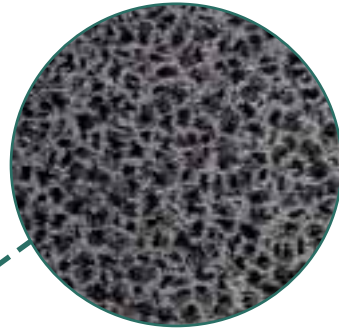
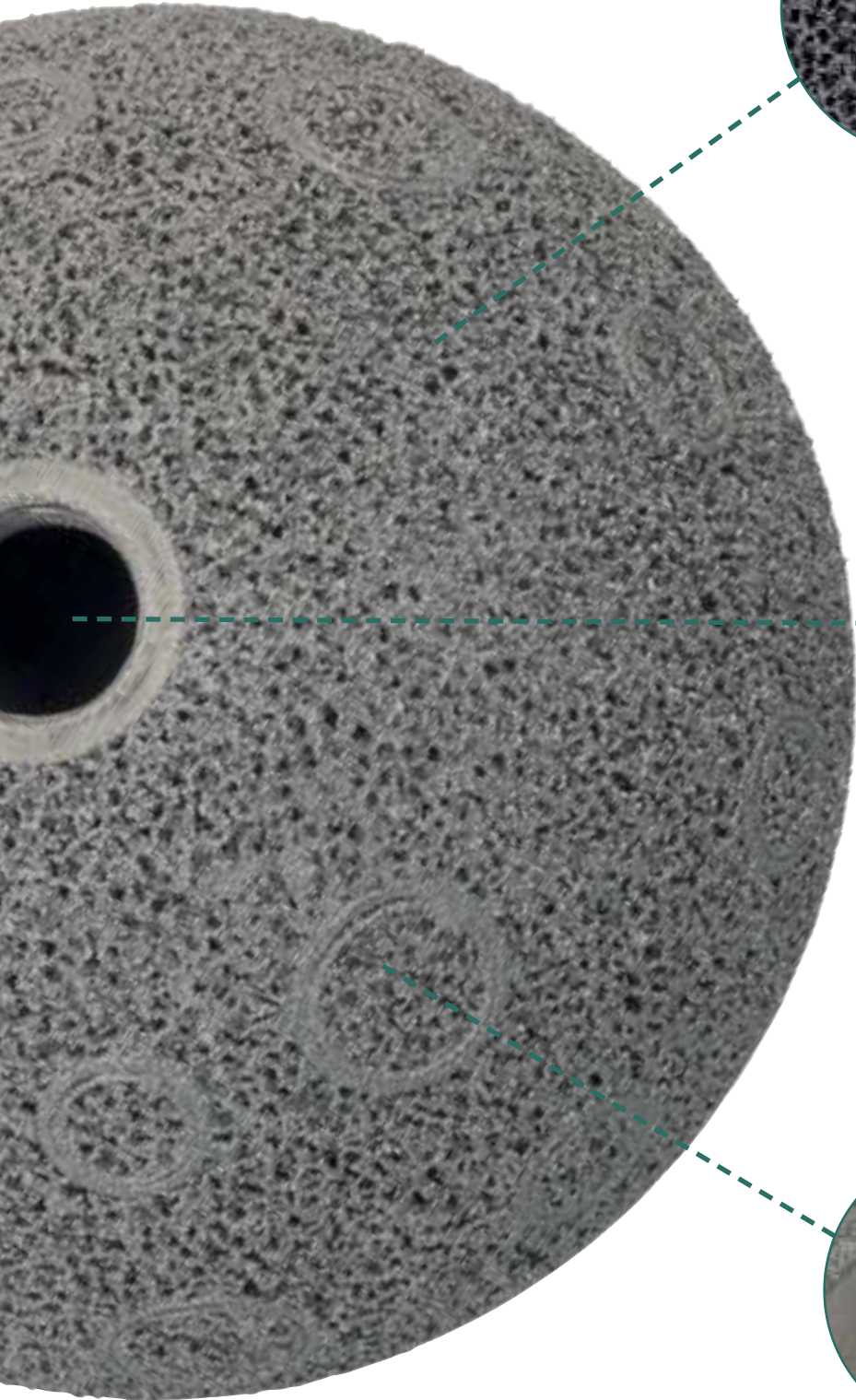

bone side
EPORE® structure



M10x1 Apex Hole for
a safe implantation

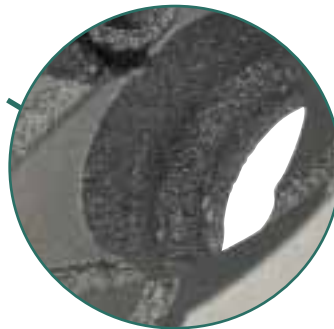

3 holes for
the usage of
8mm
cancellous screws
(holes are closed)

DESIGN FEATURES

cement grooves
for better anchoring

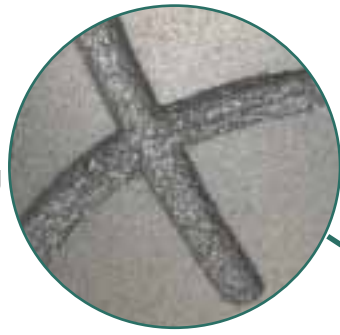

combination with
EcoFit® 2M cup
cemented

9 holes for the
usage of spongiosa
screw flat head 6.5mm
(holes are closed)



shim for the usage of spongiosa screw
flat head 6.5mm in bore holes of 8mm
cancellous screw



SURGICAL TECHNIQUE

Prepare the acetabulum so freely that it is possible to explant all the implant components to be revised and check whether an augment is to be used. This surgical technique requires both sufficient exposure of the acetabulum and straight access for the 3.2 mm K-wire and the 8 mm screw to be implanted subsequently. For reaming the acetabulum, reamers in 2mm (on request also in 1mm) increments are available. Reaming of the present defect to a spherical defect, taking into account the corresponding anteversion and inclination to achieve the correct cup position. Ream line-to-line, example: 52mm reamer means 52mm implant. The PressFit of the individual cup sizes can be found in the table below.



size	PressFit
52mm	1.6mm
56mm	1.7mm
60mm	1.8mm
64mm	1.9mm
68mm	2mm
72mm	2mm

Note:

The size of the MUTARS® PRS is graded in 4mm steps.

Use the trial implant with the longitudinal oval feeler holes (trial cup MUTARS® PRS) and the positions of the three drill holes for the 8mm screw. The trial should correspond to the outside diameter of the reamer. Define the optimal cup position and choose the appropriate hole for the 8mm screw. Check in parallel for possible osteolysis and build it up accordingly with a burr and a small plaster with allograft or ceramic bone substitute (e.g. Cerasorb®).

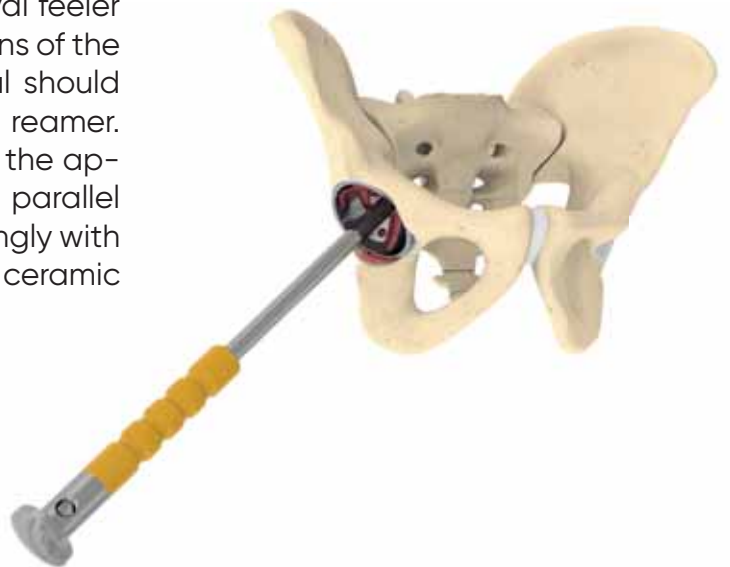

SURGICAL TECHNIQUE

The marking of the entry point for the 3.2mm K-wire for the optimal position of the 8mm screw occurs either free-hand or by using a targeting instrument. The use of the target instrument is an option here, but can only be used in the lateral position. The tip of the guide sleeve must be attached percutaneously to the posterior superior iliac spine.

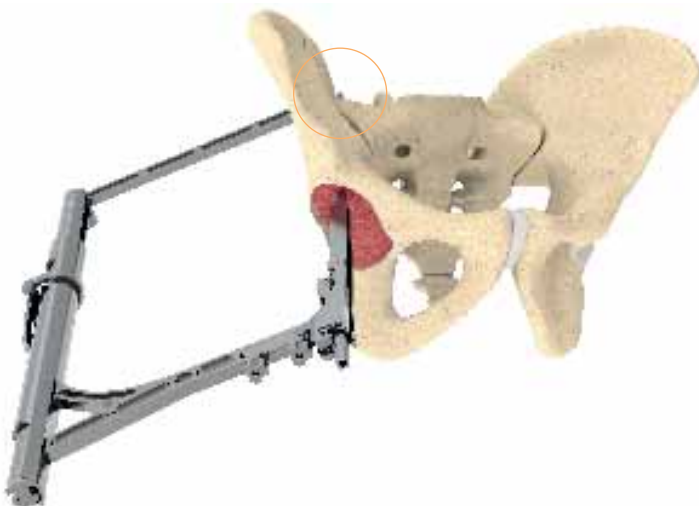
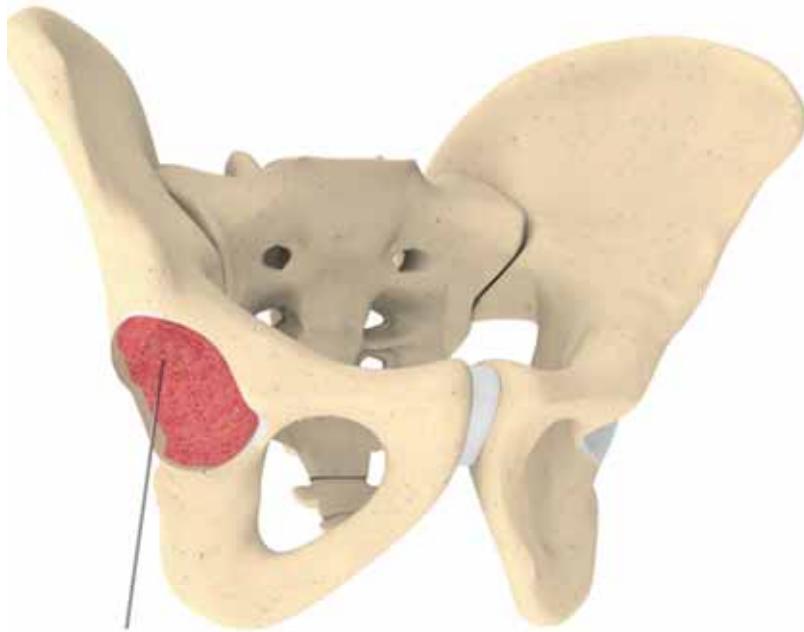

MUTARS® ic



Pelvis Targeting Device

implantcast

Detailed information regarding the usage of the pelvic targeting device can be found in the surgical technique.

SURGICAL TECHNIQUE

The setting of the K-wire in the selected position of the 8mm screw can either be done with the help of the trial cup or by hand. The aim is a long position in the direction of the posterior superior iliac spine. Set the K-wire. Threading the trial cup with the help of a drilling jig (3.2mm) to maintain the technically possible pivoting angle. It is recommended to check the position of the K-wire by X-ray in several levels in order to determine the correct screw position at the same time. Re-insert the trial cup and determine the appropriate screw hole. X-raying the position of the cup is recommended. If available by using a 3D C-arm.

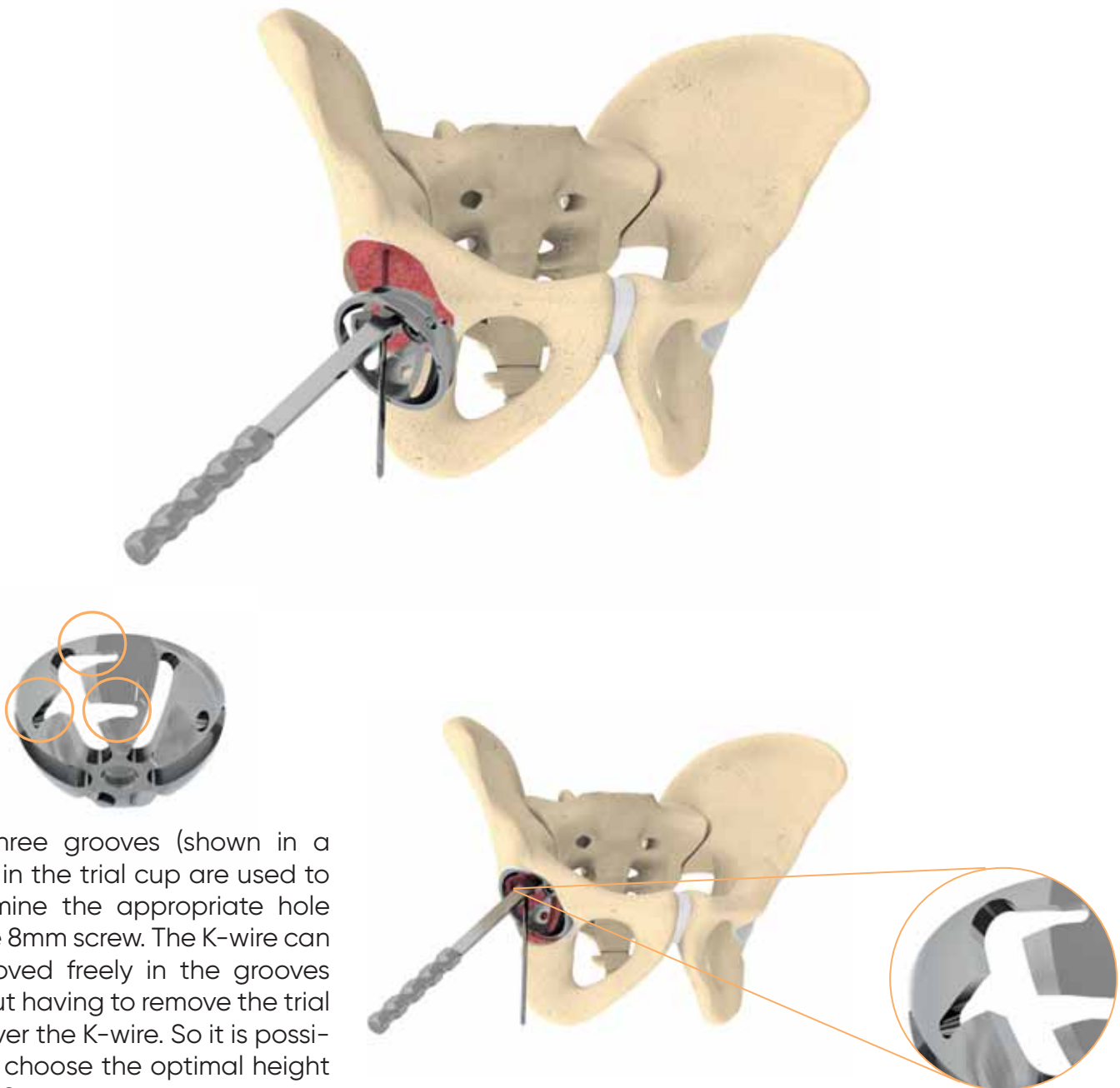

The three grooves (shown in a circle) in the trial cup are used to determine the appropriate hole for the 8mm screw. The K-wire can be moved freely in the grooves without having to remove the trial cup over the K-wire. So it is possible to choose the optimal height of the 8mm screw.

SURGICAL TECHNIQUE

After removing the trial cup, the correctly positioned K-wire is used to drill a cannulated \varnothing 6mm drill for the 8mm screw. If necessary, start this step with a cannulated 4mm drill. If necessary, let the drill walk backwards to impact cancellous bone and to avoid drilling via falsa. Check the drill channel for secure intraosseous position by using a tactile instrument, if necessary with a new representation by X-ray in two planes.

The depth depends on the bone position or the height of the defect in relation to the position of the planned center of rotation. Remove the crunch plugs by right- or leftturning and levering out from the cup that are to be covered with screws. It is recommended to remove the crunch plugs outside of the situ before hammering in the cup.

Note:

If possible, the 6mm drill should compress the full length of the planned screw or at least 1cm less. There must still be enough bone in the planned axis in the x-ray.

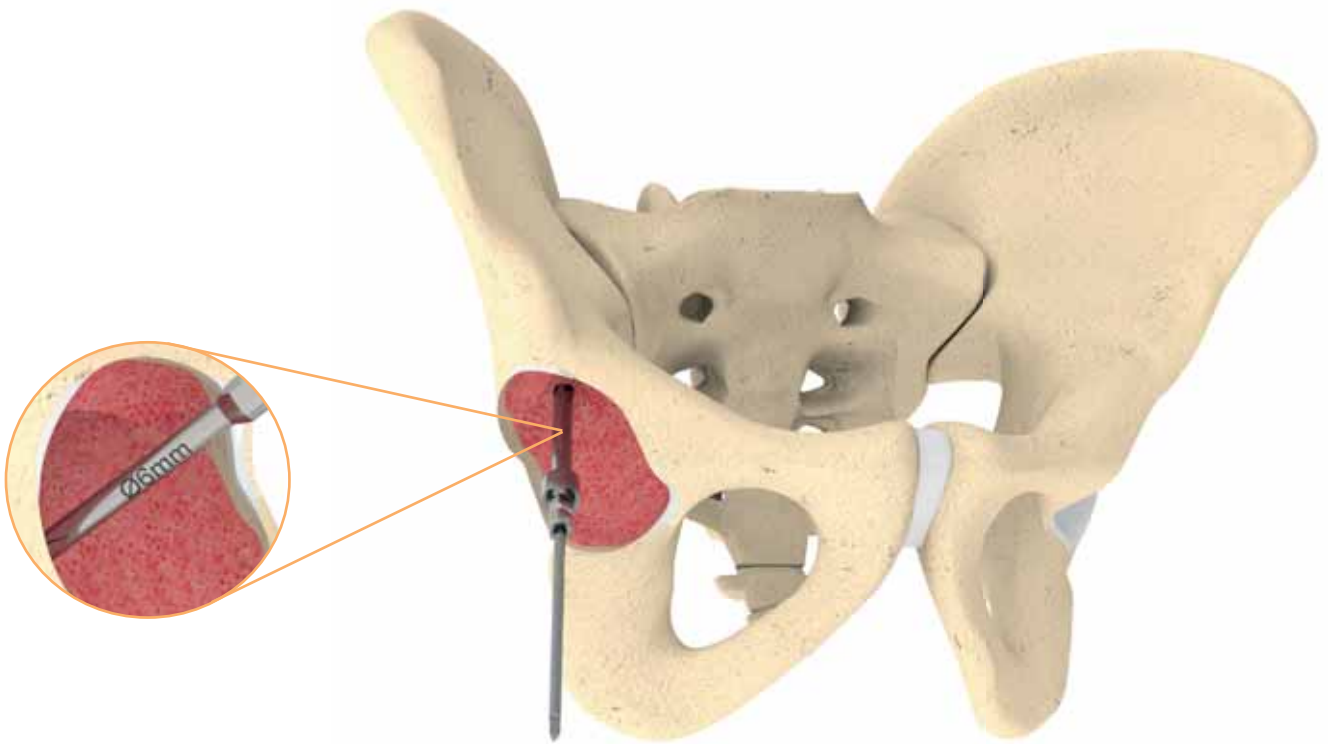

Due to the thread at the base of the K-wire, it has to be removed with the machine running backwards.

Note:

Please note here that breaking out the crunch plugs can cause sharp edges at the break ends.

SURGICAL TECHNIQUE

Insertion of a K-wire 2mm (which is not included in the set) or the pin into the hole that has been prepared for the 8mm screw. Place the cup over the lying K-wire and bring the cup into the appropriate position, taking into account the pelvic orientation. The K-wire should sit loosely and move freely. Knock in the cup, but not yet in its final fixed position. Remove the cup impactor and move freely. Knock in the cup, but not yet in its final fixed position. Remove the cup impactor. Before placing the screw, the borehole should be palpated with calliper curved \varnothing 2,0mm. Determine the required screw length with the corresponding depth gauge and insert the 8mm screw with a 5mm screwdriver. Continue tightening the screw under X-ray control without blocking the cup. Then correct the anteversion of the cup around the screw (if necessary with a tappet) and hammer in firmly with the cup impactor. Remove the impactor and check the contact with the acetabular ground through the apex hole. Place further cancellous bone screws 6.5mm under X-ray control and tighten the screw 8mm firmly. If necessary, insert additional allograft or ceramic bone substitute via the apex hole and then close it with the central hole cover plug. The 8mm cancellous screw enables a pivoting angle of 10° .

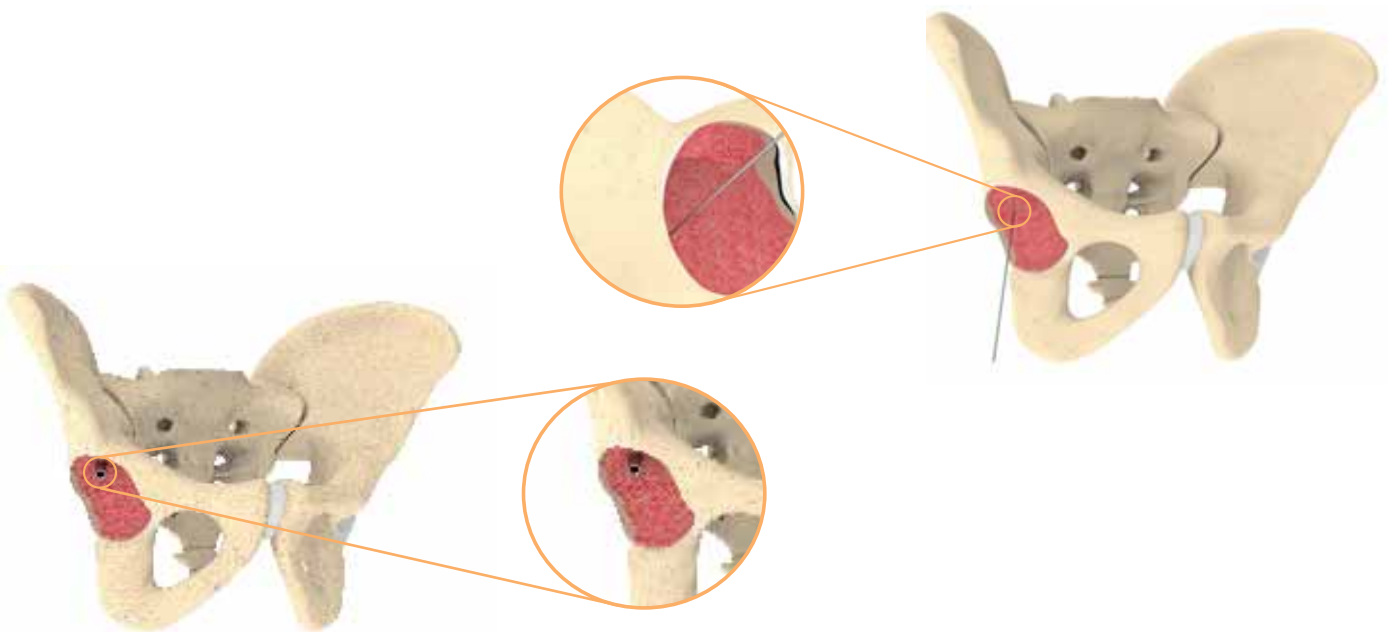

It is recommended to use one or two additional spongiosa screw flat head \varnothing 6,5mm.

Note:

The following drill bits are available for preparing the screw holes:

drill with depth marking:

- \varnothing 3.2/15mm
- \varnothing 3.2/20mm
- \varnothing 3.2/25mm
- \varnothing 3.2/40mm
- \varnothing 3.2/60mm
- \varnothing 3.2/115mm



flexible drilling shaft:



SURGICAL TECHNIQUE

Note:
Do not tighten the cancellous bone screw 8mm approx. 4-5mm before the final seat before the final position of the cup is reached, in order to counteract tilting of the cup and, if necessary, further holes are occupied. At least one additional screw 6.5mm should be used to secure the rotational forces depending on the PressFit.

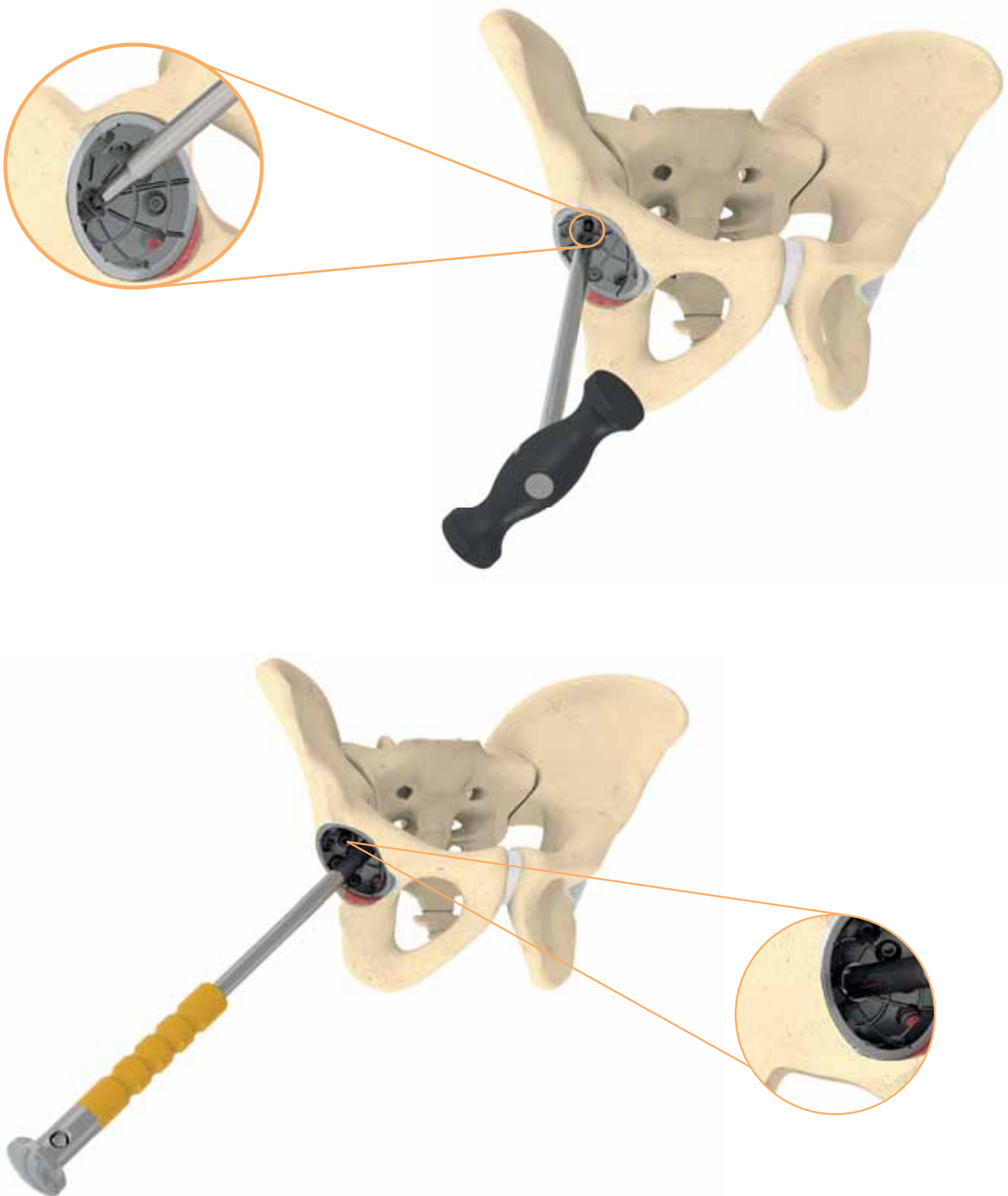

SURGICAL TECHNIQUE

Measure the screw length using a depth gauge.

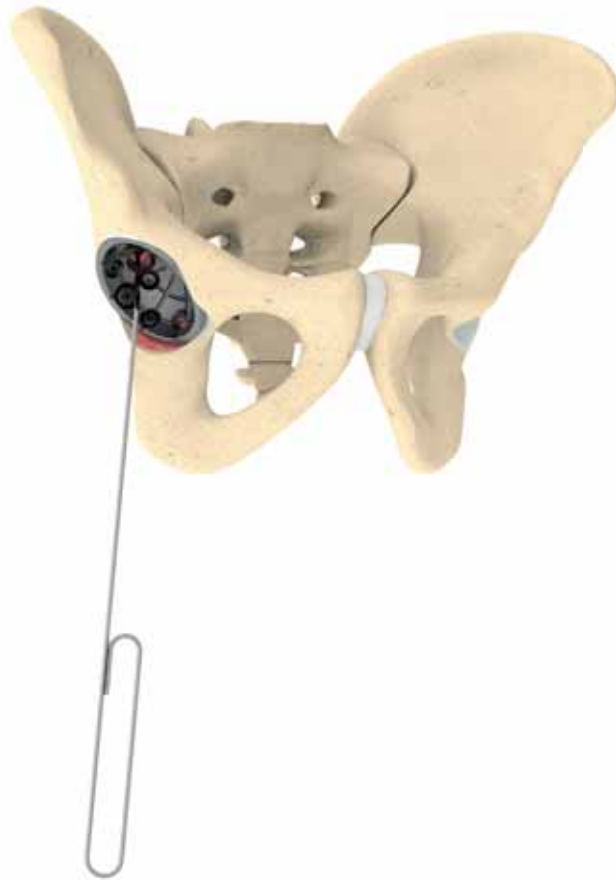

There is also the option of placing 6.5mm flat head cancellous bone screws in the 8mm bore holes by using a shim. Here it must be ensured that the shim (shape: conical) is inserted correctly (see Fig.)

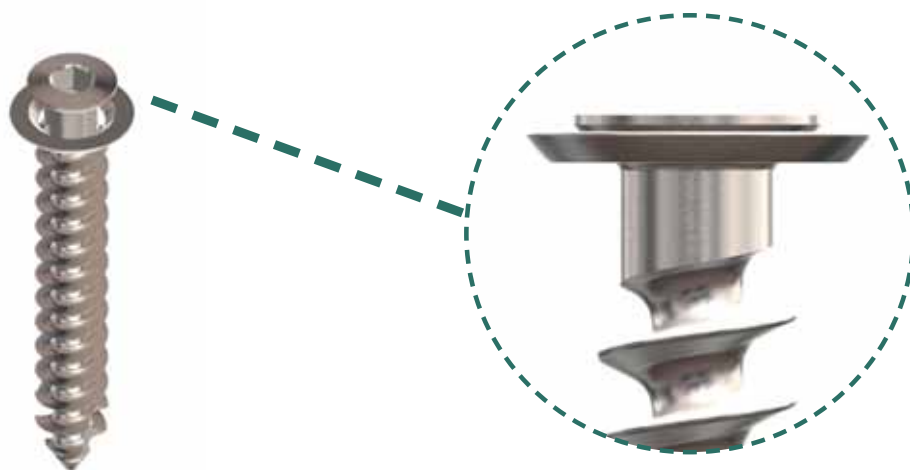

SURGICAL TECHNIQUE

First tighten the cancellous bone screw 6.5mm and then the cancellous bone screw flat head 8mm.

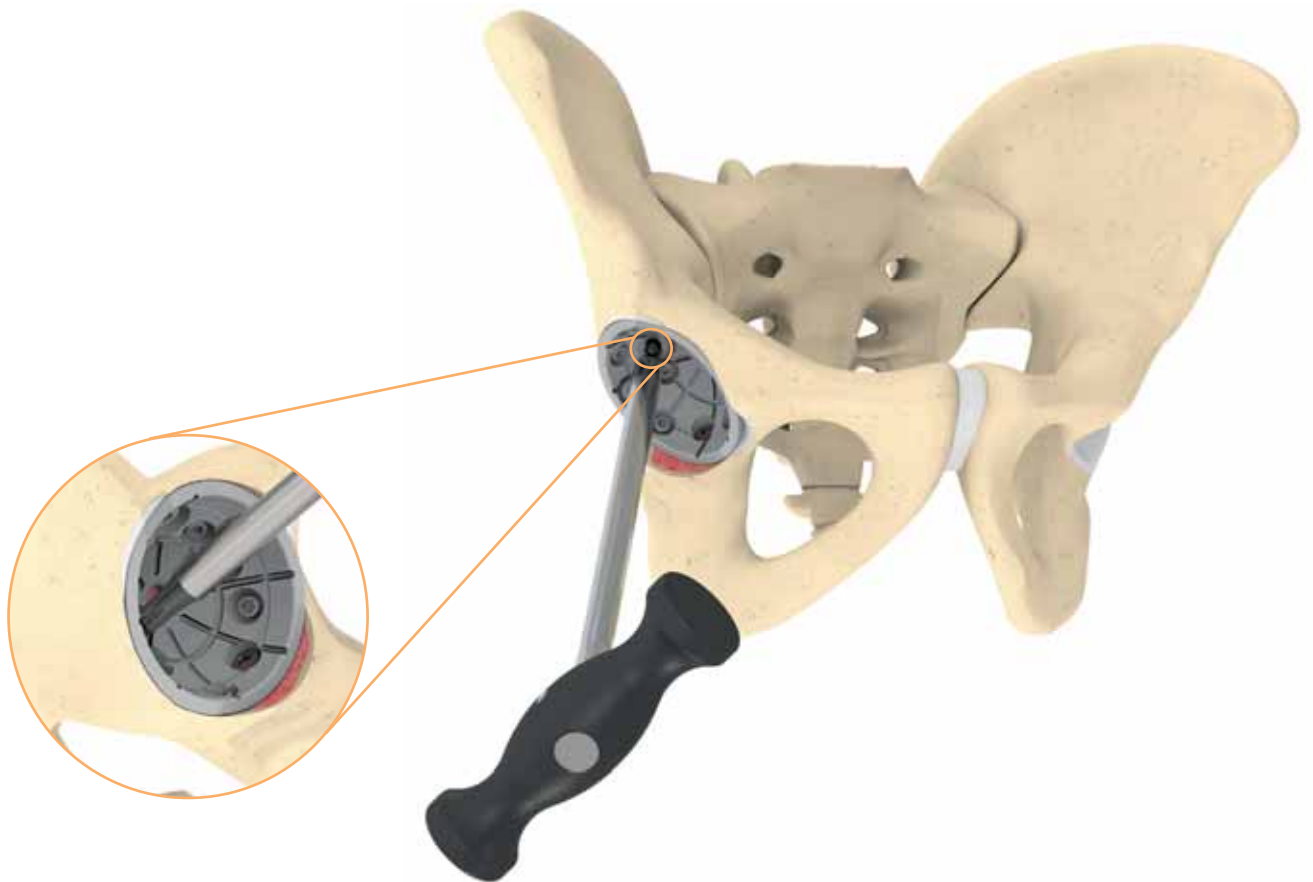
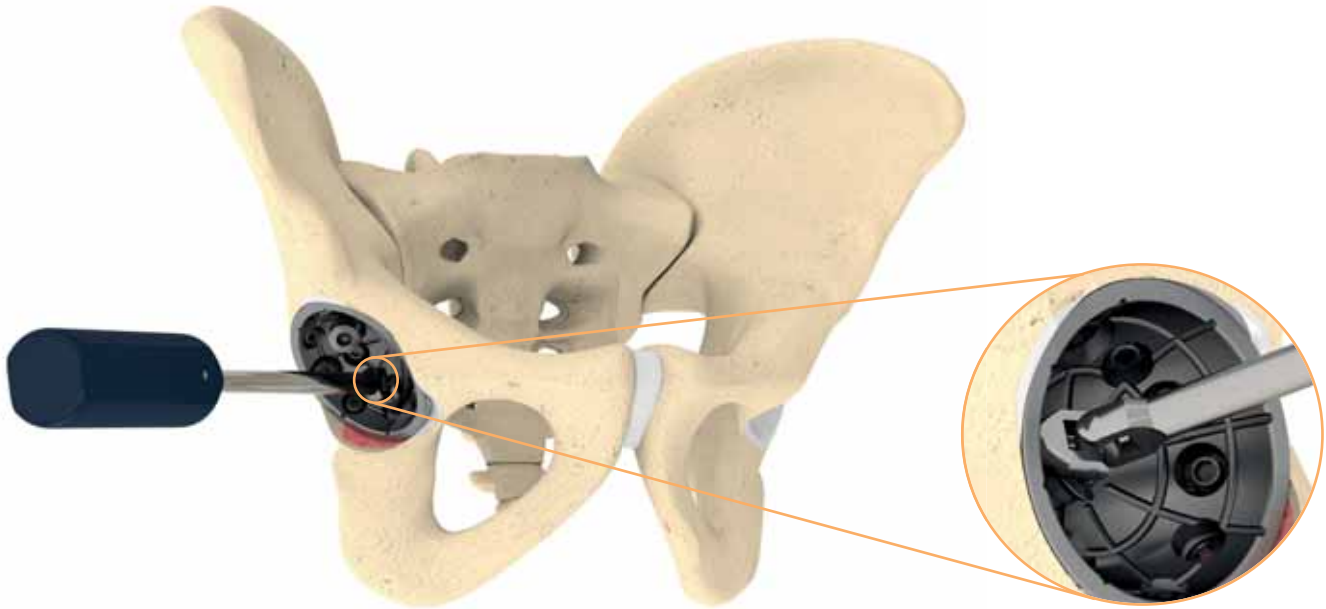

SURGICAL TECHNIQUE

The final position and depth of the cup can be checked either through the hole in the base of the cup or with an X-ray. Before you are cementing the EcoFit® 2M cup or the Müller II PE acetabular cup, insert the central plug M10x1. By cementing the aforementioned cup in its place, the screws are also angularly stable.



Further information can be found in the surgical technique EcoFit® 2M cup or PE-cup Müller II.

PRODUCT- INFORMATION

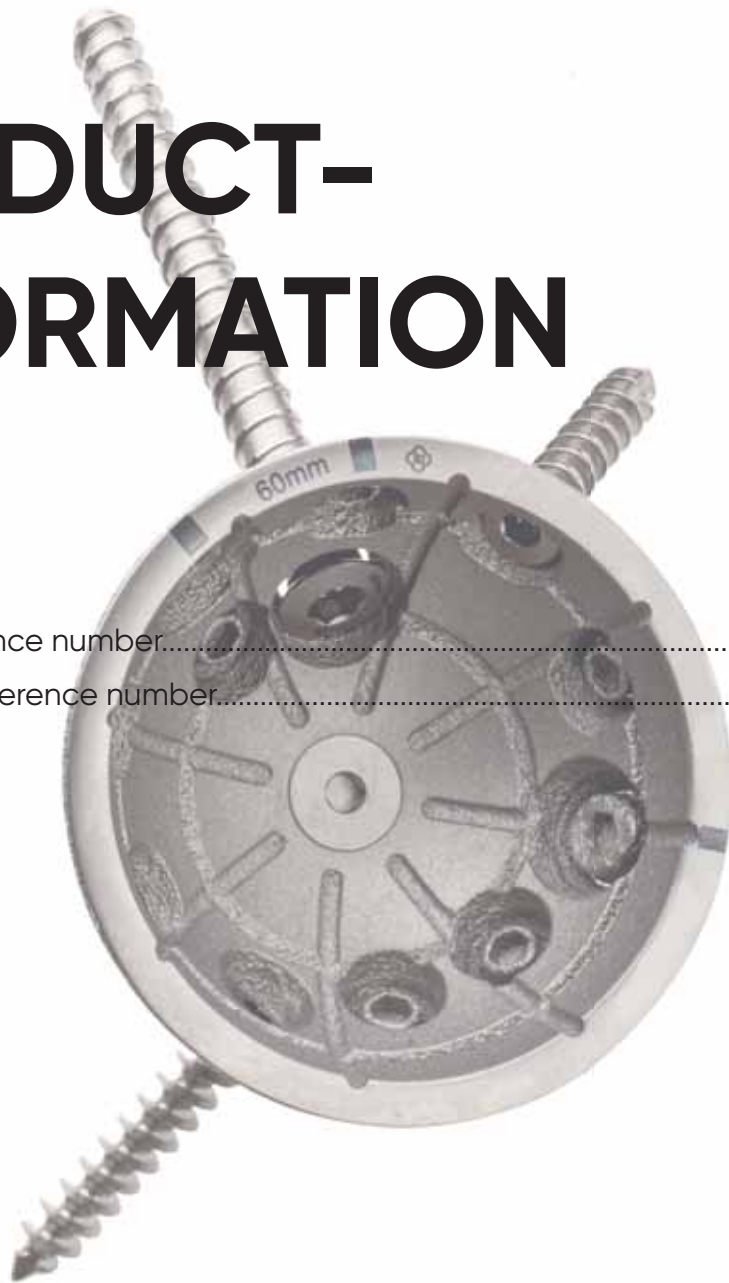

IMPLANTS reference number.....	18
INSTRUMENTS reference number.....	20

IMPLANTS



MUTARS® PRS incl. central hole cover

Mat.: $TiAl_6V_4$ with EPORE®

REF	size
0296-0052	52mm
0296-0056	56mm
0296-0060	60mm
0296-0064	64mm
0296-0068	68mm
0296-0072	72mm



cancellous screw Ø 8mm

Mat.: implatan®, $TiAl_6V_4$ acc. to ISO 5832-3

REF	length
0287-0070	8x70mm
0287-0080	8x80mm
0287-0090	8x90mm
0287-0100	8x100mm



spongiosa screw flat head Ø 6,5mm

Mat.: implatan®, $TiAl_6V_4$ acc. to ISO 5832-3

REF	length
0280-1015	15mm
0280-1020	20mm
0280-1025	25mm
0280-1030	30mm
0280-1035	35mm
0280-1040	40mm
0280-1045	45mm
0280-1050	50mm
0280-1055	55mm
0280-1060	60mm
0280-1065	65mm
0280-1070	70mm
0280-1075	75mm
0280-1080	80mm

IMPLANTS

EcoFit® 2M cup cemented

Mat.: implavit®, CoCrMo acc. to ISO 5832-4

REF	size (inner-Ø/outer-Ø)
0220-1144	38/44mm
0220-1146	40/46mm
0220-1148	42/48mm
0220-1150	44/50mm
0220-1152	46/52mm
0220-1154	48/54mm
0220-1156	50/56mm
0220-1158	52/58mm
0220-1160	54/60mm
0220-1162	56/62mm
0220-1164	58/64mm



EcoFit® 2M cup cemented TiN

Mat.: implavit®, CoCrMo acc. to ISO 5832-4 with TiN-coating

REF	size (inner-Ø/outer-Ø)
0220-1144N	38/44mm
0220-1146N	40/46mm
0220-1148N	42/48mm
0220-1150N	44/50mm
0220-1152N	46/52mm
0220-1154N	48/54mm
0220-1156N	50/56mm
0220-1158N	52/58mm
0220-1160N	54/60mm
0220-1162N	56/62mm
0220-1164N	58/64mm



shim for spongiosa screw flat head 6,5mm

Mat.: implatan®, TiAl₆V₄ acc. to ISO 5832-3

REF
0296-0000



INSTRUMENTS

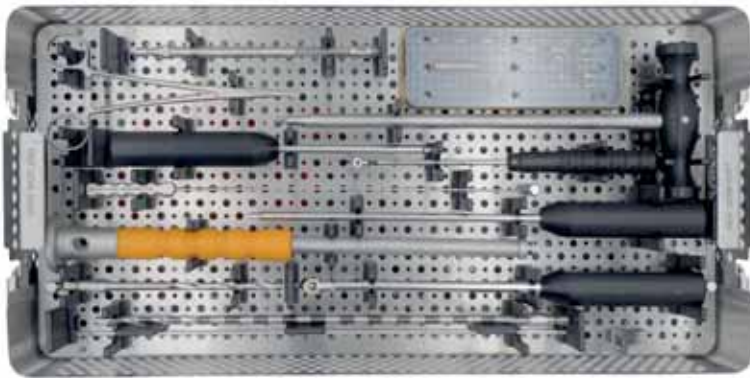

0296-0001
MUTARS® PRS container
(upper layer)

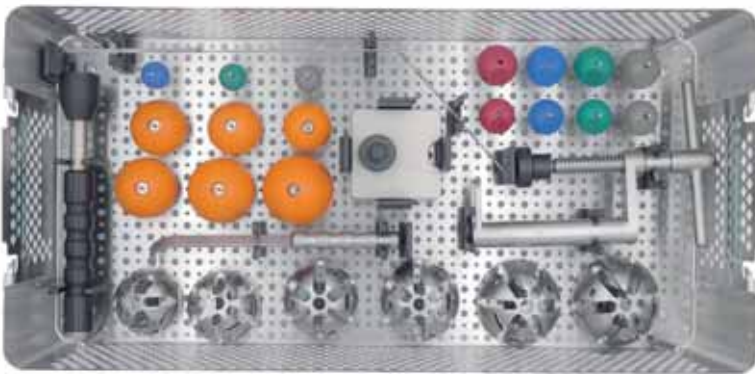

0296-0001
MUTARS® PRS container
(bottom layer)



0296-0002
acetabulum reamer
MUTARS® PRS container
(bottom layer)



0296-0002
acetabulum reamer
MUTARS® PRS container
(upper layer)

INSTRUMENTS

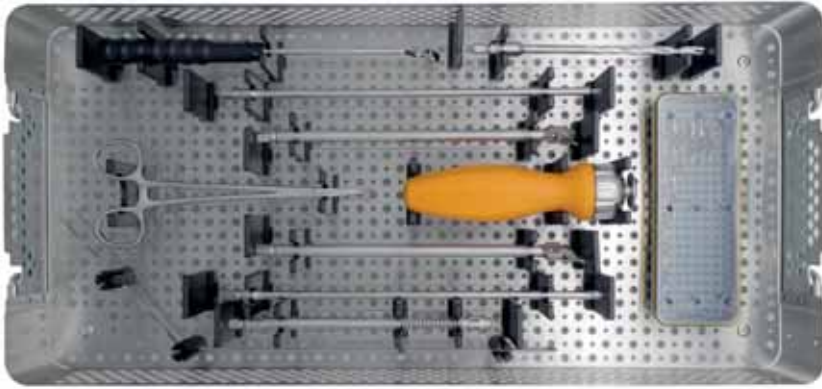

0296-0003
container for
screw instruments modular
MUTARS® PRS

INSTRUMENTS

CONTAINER 0296-0001

shell impactor
REF 0282-0030



flexible screw driver 3,5mm
REF 0270-1002



screw driver long 3,5mm
REF 0280-1006



anged drill guide 3,2mm
REF 0282-1001



hexagon screw driver with T-handle 5mm
REF 0287-1003



guided pin
REF 0296-5002



drill bit cannulated Ø 6mm
REF 0296-5001



central screw for retaining instrument curved
REF 0296-5004



fixation pin 3,2mm x 350mm with threaded 15mm (2x)
REF 4224-0035



INSTRUMENTS

MUTARS®

hexagon screw driver 5 mm

REF 7608-1050



plug remover

REF 0220-2012



ball probe 240mm

REF 7512-0008



drill with depth marking

REF 0232-0015 Ø 3,2/15mm

REF 0232-0020 Ø 3,2/20mm

REF 0232-0025 Ø 3,2/25mm

REF 0232-0040 Ø 3,2/40mm

REF 0232-0060 Ø 3,2/60mm

REF 0232-0115 Ø 3,2/115mm



drill Ø 6/300mm cannulated with depth marking

REF 0260-0300



bolt retainer clamp 180mm

REF 0282-1002

alternatively:

bolt retainer clamp I

REF 0282-1050



flexible drill shaft ic

REF 0282-2120



depth gauge 0-100mm

REF 0270-1070



INSTRUMENTS

CONTAINER 0296-0001

trial head taper 12/14mm

REF 7965-2200 Ø 22mm, S
REF 7965-2205 Ø 22mm, M
REF 7965-2210 Ø 22mm, L



trial head taper 12/14

REF 7965-2800 Ø 28mm, S
REF 7965-2805 Ø 28mm, M
REF 7965-2810 Ø 28mm, L
REF 7965-2815 Ø 28mm, XL

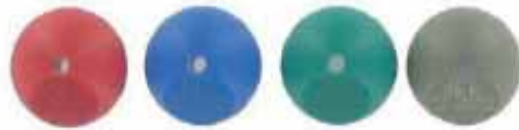

trial head taper 12/14

REF 7965-3200 Ø 32mm, S
REF 7965-3205 Ø 32mm, M
REF 7965-3210 Ø 32mm, L
REF 7965-3215 Ø 32mm, XL



2M trial head

REF 2950-2238 22/38mm
REF 2950-2842 28/42mm
REF 2950-2844 28/44mm
REF 2950-3248 32/48mm
REF 2950-3252 32/52mm
REF 2950-3256 32/56mm



femoral head impactor

REF 2950-0039



ic head assembling tool

REF 2900-2000



INSTRUMENTS

trial cup for MUTARS® PRS

REF 0296-0152 size 52mm

REF 0296-0156 size 56mm

REF 0296-0160 size 60mm

REF 0296-0164 size 64mm

REF 0296-0168 size 68mm

REF 0296-0172 size 72mm



retaining instrument curved

REF 0296-5003



CONTAINER 0296-0002

acetabulum reamer low profile

2950-3048 / 2960-3048 Ø 48mm

2950-3049 / 2960-3049 Ø 49mm

2950-3050 / 2960-3050 Ø 50mm

2950-3051 / 2960-3051 Ø 51mm

2950-3052 / 2960-3052 Ø 52mm

2950-3053 / 2960-3053 Ø 53mm

2950-3054 / 2960-3054 Ø 54mm

2950-3055 / 2960-3055 Ø 55mm

2950-3056 / 2960-3056 Ø 56mm

2950-3057 / 2960-3057 Ø 57mm

2950-3058 / 2960-3058 Ø 58mm

2950-3059 / 2960-3059 Ø 59mm

2950-3060 / 2960-3060 Ø 60mm

2950-3061 / 2960-3061 Ø 61mm

2950-3062 / 2960-3062 Ø 62mm

2950-3063 / 2960-3063 Ø 63mm

2950-3064 / 2960-3064 Ø 64mm

2950-3065 / 2960-3065 Ø 65mm

2950-3066 / 2960-3066 Ø 66mm

2950-3067 / 2960-3067 Ø 67mm

2950-3068 / 2960-3068 Ø 68mm

2950-3069 / 2960-3069 Ø 69mm

2950-3070 / 2960-3070 Ø 70mm

2950-3072 / 2960-3072 Ø 72mm



INSTRUMENTS

handle for acetabulum reamer A/O long

REF 2950-2010



CONTAINER 0296-0003

drill with depth marking

REF 0232-0015 Ø 3,2/15mm

REF 0232-0020 Ø 3,2/20mm

REF 0232-0025 Ø 3,2/25mm

REF 0232-0040 Ø 3,2/40mm

REF 0232-0060 Ø 3,2/60mm

REF 0232-0115 Ø 3,2/115mm



cardan screw driver modular

REF 0270-1009 3,5mm

REF 0270-1030 5mm



depth gauge

REF 0270-1070 0-100mm



angled drill guide

REF 0282-1001 3,2mm



bolt retainer clamp

REF 0282-1002 180mm



flexible drill shaft ic

REF 0282-2120



drill bit cannulated

REF 0296-5001 Ø 6mm



INSTRUMENTS

ratchet handle

REF RIV-10-11-02DB



screw driver long modular

REF 0280-1009 3,5mm



screw driver straight modular

REF 0270-1050 5mm



single instruments

calliper curved Ø2,0mm

REF 0292-0001

note: sterile, single use!



ADDITIONAL INFORMATION



PREOPERATIVE AND POSTOPERATIVE INSTRUCTIONS.....	29
INDICATIONS AND KONTRAINICATIONS.....	30
RISKFACORS.....	31

PREOPERATIVE AND POSTOPERATIVE INSTRUCTIONS

Preoperative Instructions

A preoperative planning is mandatory for optimal results. Before surgery a surgical planning with regard to the dimensions of the prosthetic model and the positioning of the implant components in the bone has to be carried out by the surgeon.

For this purpose, x-ray templates are available:

Digital templates: Digital templates are included in the data base of the common planning systems. For missing templates, please contact the provider of the planning software and request for these templates.

Radiographic templates: Alternatively, radiographic templates are available in various scale factors, which can be obtained from your local representative.

The surgeon must ensure that:

- all needed components are available during surgery. An adequate number of all necessary implant components will be available during surgery. It should be determined whether the implantation should be done cemented or cementless.
- all instruments necessary will be present for surgery and that they match the implants being used. Only instruments designed for use with the implant system by implantcast GmbH should be used. An exception are exclusively the standardized instruments used during surgery.
- the correct sized instruments are used during surgery to prevent damage to the implants.

Post-operative Instructions

Post-operative patient care, patient instructions and warnings are of the utmost importance. The use of an external support of the operated extremity for a limited period is recommended. Active and passive movements of the operated extremity should be monitored.

The post-operative regime should be aimed at the prevention of overloading of the operated extremity and stimulation of the healing process.

Regular monitoring of the position and condition of the prosthetic components and the surrounding bone is recommended.

INDICATIONS AND KONTRAINDICATIONS

Intended Use

The MUTARS® PRS is intended for use in total hip arthroplasty for a stable bridging of large bone defects in the acetabulum with the use of screws. It is intended for bone-side cementless and implant-side cemented fixation. When using Spongiosa Screw Flat Head 6,5mm in one of the holes which are determined for the 8mm screws, the appropriate shim has to be used.

Intended Use spongiosa screw flat head Ø 6.5mm/spongiosa screw Ø 8mm

Bone Screws are intended for screwing into the bone for primary and/or permanent stable anchorage of an implant in case of inadequate primary stability.

Indications

The decision for replacement of the joint should be based on careful evaluation. The indication for this type of surgery should only be made when all other conservative or surgical alternatives are less promising. Danger of post-operative complications can be limited by careful evaluation of the individual anatomical and load conditions, the condition of the soft tissues and the condition of the bone bed for the implants. The provision of implants is generally indicated only in patients whose skeleton is fully grown.

Before intervention, preoperative examinations should be performed. The examinations depend on the patient's medical history.

Under consideration of these conditions, for the hip joint replacement with the MUTARS® PRS in the acetabular area are applied to the following indications:

- non-inflammatory degenerative joint disease including osteoarthritis and avascular necrosis,
- post-traumatic osteoarthritis,
- fractures,
- rheumatoid arthritis,
- acetabular defects.

The following additional indication applies to the hip joint replacement with the MUTARS® PRS:

- large cavitary or segmental acetabular defects (up to type 3a of Paprosky classification).

The indications of corresponding endoprosthesis system must also be considered.

Contraindications

The longevity of an orthopaedic implant can be reduced by biological aspects, material characteristics and bio-mechanical factors. Therefore, a careful examination of the indications is recommended in overweight patients, in patients with very high joint loads due to high physical activity as well as in patients younger than 60 years.

The metal augments are contraindicated in cases of:

- Allergy to one of the implant materials. (The label on the secondary packaging of the respective component indicates the materials used. It is strongly recommended to perform an allergy test.)
- Ongoing infections.
- Physiological or Anatomic conditions, which preclude or are not expected to maintain an adequate bony support of the implant or do not allow the implantation of a sufficiently large prosthesis.
- Bone tumors (metastases) in the implant fixation area,
- untreated vascular diseases which limit blood supply to the affected limb,
- metabolic disorders that may impair bone formation.

In case of insufficient quantity and quality of bone stock, an alternative prosthetic treatment allowing for sufficient bony fixation should be considered.

The contraindication of the corresponding endoprosthesis system must also be considered.

RISKFACTORS

Risk factors

The following risk factors may affect the success of the metal augments:

- excessive loading of the operated joint by strong physical work and/or inappropriate sports,
- severe deformities which lead to an impairment of the anchorage bone fixation or the exact positioning or the function of the implant,
- therapies that may affect bone quality,
- muscle insufficiency,
- neuromuscular diseases that can impair of the affected limb,
- conditions that restrict the patient's ability or willingness to comply with medical instructions, especially during the healing process,
- obesity,
- nicotine and/or drug abuse,
- alcoholism,
- previous surgeries on the affected limb,
- diabetes,
- psoriasis,
- intra-articular injection of corticosteroids.

Implant Specific Complications:

There is a risk that the special clamping plugs (crunch plugs) may come loose from the MUTARS® PRS during the implantation of the MUTARS® PRS. If necessary, the allowed bone screws as described in chapter 'Combinability' can be used to support the fixation. The screw holes in the MUTARS® PRS are covered with special clamping plugs (crunch plugs), which must be removed first. There is a risk that the crunch plugs can only be removed with difficulty. To minimize this risk, it is essential to follow the instructions described in the respective surgical technique (MUPRSOPE).



implantcast GmbH
Lüneburger Schanze 26
21614 Buxtehude
phone.: +49 4161 744-0
fax: +49 4161 744-200
e-mail: info@implantcast.de
internet: www.implantcast.de



Your local distributor:

MUPRSOPE--200922

