

High Cube 20 ft ISO Container for Ideal IM-GO 120 Oxygen Generator System



- Exhaust & suction ducts, two main doors, one emergency exit door, air conditioner, interior lighting, emergency interior lighting, main power distribution cabinet, all cabling and piping, outdoor lighting system, ambient oxygen sensor are included.
- All equipments will be connected each other and tested at İdeal Makina workshop in İstanbul.
- There will be High Cube 20 ft ISO locked, heavy duty, heat and noise insulated container where all equipments will be assembled in.
- The main power distribution panel with all required thermal switches will be installed in container.
- The mechanical and electrical connections will be tested before delivery.
- FAT (Factory Acceptance Test) will be done and reported by İdeal Makina Technical Service Team.
- No installation on-site, No leakage possibility, Easy commissioning on-site, PLUG & PLAY.

Alpaslan Tekin
General Manager
Dated on 17.02.2023

idealMakina®
İDEAL MAKİNA END. ÜRÜN. SAN. VE TİC. A.Ş.
Esenkent Mh. Nato Yolu Cd. No:277/8 34776 Ümraniye-İST.
Sarıgazi V.D 470 097 1928 Tic Sic. No: 530388
www.idealmakina.com

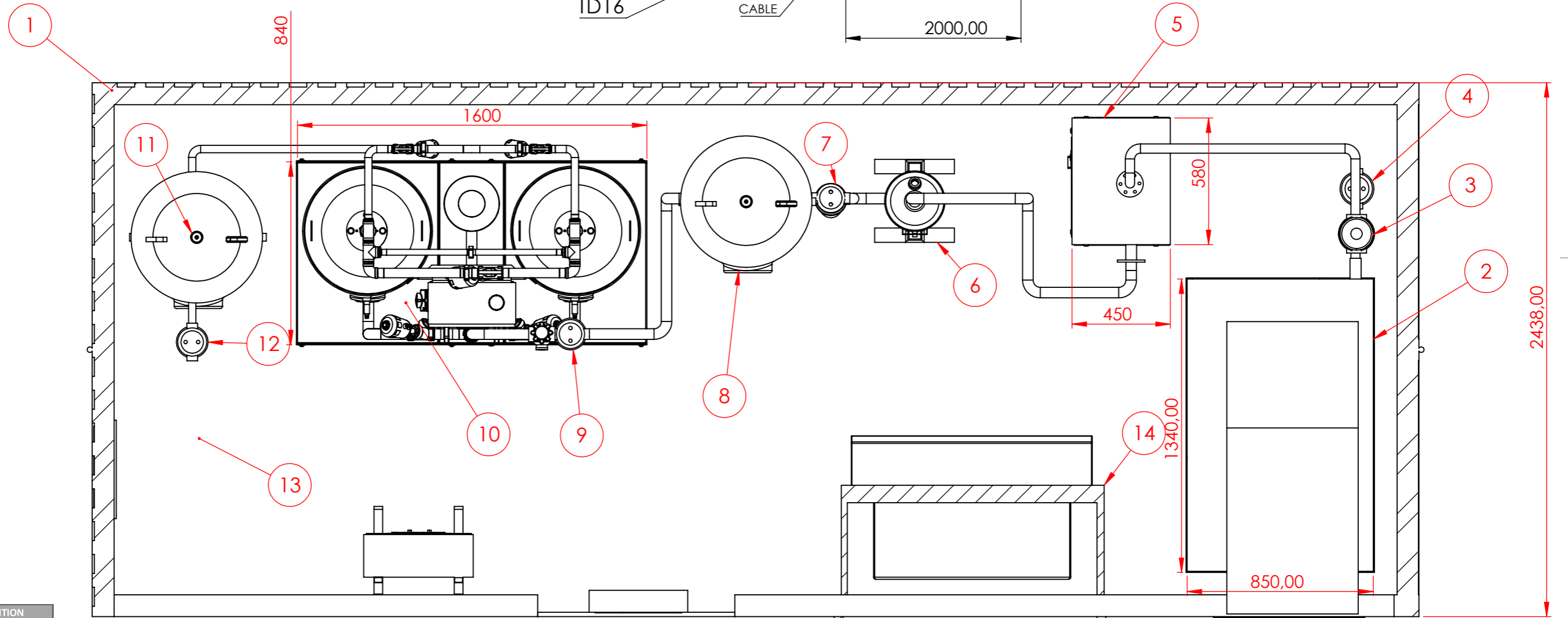
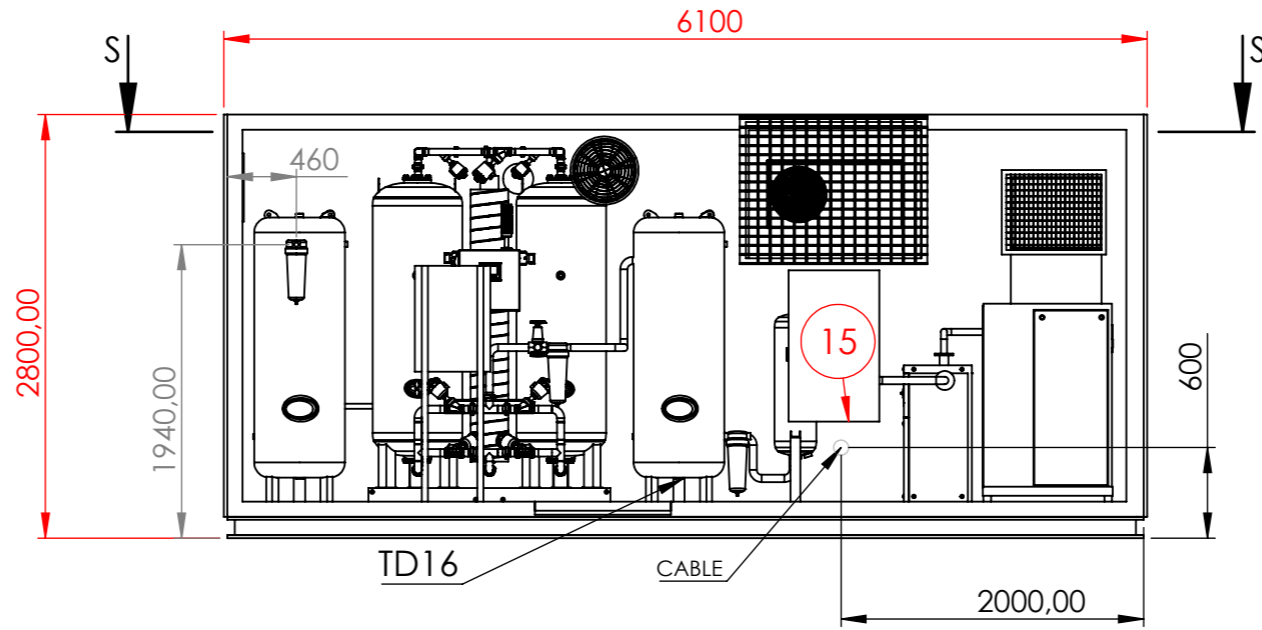

S-S
1 : 20

| PART NO | DEFINITION |
|---------|---------------------|
| 1 | 20 Ft HC Container |
| 2 | INVERSYS 22 |
| 3 | CKL WATER SEPERATOR |
| 4 | R FILTER |
| 5 | AMD 52 AIR DRYER |
| 6 | ICT 250 |
| 7 | P FILTER |
| 8 | 500 LT |
| 9 | S FILTER |
| 10 | IM-GO 120 |
| 11 | 500 LT |
| 12 | WALKER A3051 |
| 13 | CHANGEOVER |
| 14 | AIR CONDITIONER |
| 15 | CONTROL PANEL |

| NAME | HISTORY | SIGNATURE |
|--|------------|-----------|
| DRAWN BY: OMER ATES | 13.02.2023 | |
| APPROVED BY: EBRU ULUS | 14.02.2023 | |
| IDEAL MAKINA ENDÜSTRİ ÜRÜNLERİ SANAYİ VE TİCARET A.Ş. Esenkent Mah. Nato Yolu Cad. No:277 34776 Ümraniye/İST. Tel: 0216 540 88 55 Faks: 0216 540 88 18 www.idealmakina.com | | |
| MATERIAL: | WEIGHT: | |

ROMEDCOM SRL PLUG&PLAY
CONTAINER IDEAL IM-GO 120
OXYGEN GENERATOR SYSTEM

TOP VIEW AND EQUIPMENT LIST

A3

It is very easy to produce your own oxygen gas and fill your empty oxygen cylinders with Ideal Makina Oxygen Generators and mobile container cylinder filling stations!

Consisting of high efficiency equipment selected to work together in harmony, the only need for Container Oxygen Generator System is the power connection. It is very easy to produce your own oxygen gas and fill your empty oxygen cylinders with Ideal Makina Oxygen Generators and mobile container cylinder filling stations! By producing your own oxygen gas which is much more economical compared to the cost of your cylinder purchasings, you can fill your cylinders by yourself and can save considerably.

Pipe connections, electrical wiring, main energy distribution together with control panel and all accessories in the container are assembled in the most accurate way and ready to be used. The produced high purity oxygen gas is being filled into oxygen cylinder bundles at 150barg pressure and fully responds to your variable oxygen consumption. These systems are presenting the produced oxygen gas uninterruptedly in the desired quantity, required pressure and high purity.

Deep experience of having installed more than 500 nitrogen & oxygen generator systems for more than 16 years; IDEAL MAKINA guarantees high quality of **Plug & Play** Oxygen Generator Systems.

With the container type oxygen cylinder filling station designed by İdeal Makina with a special design, you can produce oxygen gas much more economically compared to your cylinder purchasing costs and can make serious savings!

Please contact us for our container designs that are resistant to all atmospheric conditions and corrosion. They can provide the maximum working performance required for all sound and heat insulated system units.

ADVANTAGES

- Mobile, heavy duty, sound and heat insulated, ISO locked containers
- Ready system with all electrical and mechanical assembles completed.
- Uninterrupted operation in summer and winter equipped with air conditioners and heaters
- Gas production and cylinders filling in any climate conditions on the field
- Factory-tested "ZERO LEAKAGE".
- Ease installation and commissioning on site.
- Easy transportation to another place when requested
- Little space usage with its compact structure.
- Main Power Distribution Panel
- User friendly, automatic "START STOP".
- Environment Friendly Design
- Ability to work with field type diesel electric generators



- All containers have ISO type lifting lugs and ISO locks.
- Suitable for transportation by road, sea and air freight.
- The lower chassis is made of 2/3 tear sheet metal over 100 NPU.
- Cab walls are made of 1,5mm, cabin ceiling is made of 2mm DKP trapeze sheet.
- The cabin insulation is covered with galvanized sheet on 5cm rock wool. In this way, sound and heat insulation is provided.
- G4 dust filter is used in air suction louvers.
- The isolation of the hot air ducts of the compressors is done with aluminum golf sheet on 5 cm rock wool.
- Cabin interior temperature is controlled by air conditioner and fan.
- A Main Electricity Distribution Board available in the cabin where the entire system can be controlled.
- Automatic Fire Prevention and Extinguishing Systems.
- 2 double wing container doors and 1 single wing service door on the cabin.
- Cabine primer paint is epoxy and topcoat is epoxy painted. Paint colour option according to the desired color codes.
- Details such as mechanical and electrical installations, lighting and **condensate** drain channels completed, all leakage tests are performed and ready for dispatch.

APPLICATION PHOTOS



