

Geometric tolerances after ISO14638

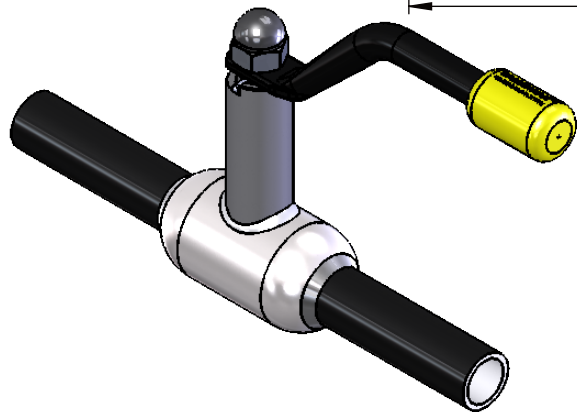

		00			
QDA	DCN	REV.	BEFORE CHANGE	DATE	BY

BROEN INTELLIGENT FLOW SOLUTIONS	MATERIAL	WEIGHT (g) 680.46		SCALE
	PART	DN015 W/W PN40	DRAW. PSA	DATE 23-02-2006
UNSPECIFIED TOLERANCES ANGLES ± 2° OTHER DIM. ± 0.2	PRODUCT	BALLOMAX GAS VALVE	APPR. JJA	DATE 15-02-2019
	CONNECTIONS	KUREK DN015 WSP PN40 GAZ	DRAWING NUMBER 7110240015	
This drawing is our property and may not be transferred to third party, copied or made use of without our permission.			SP no.:	Sheet 1 of 1

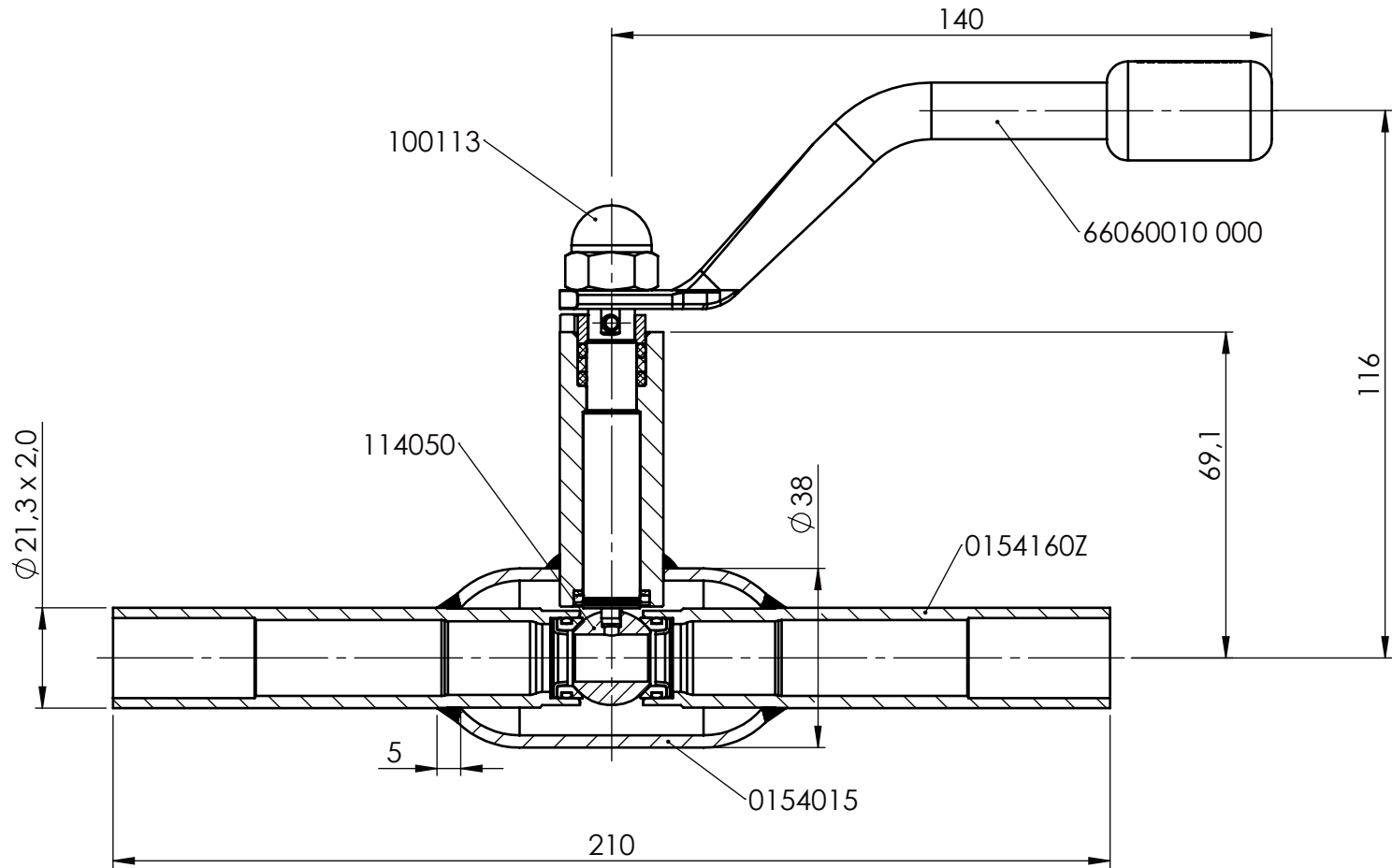
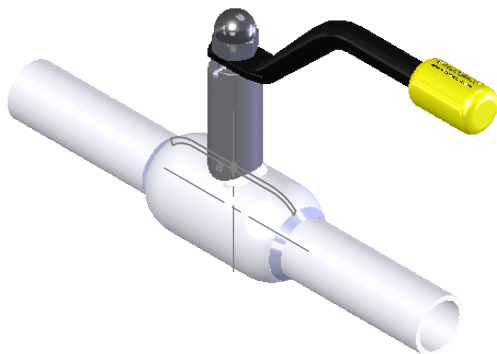
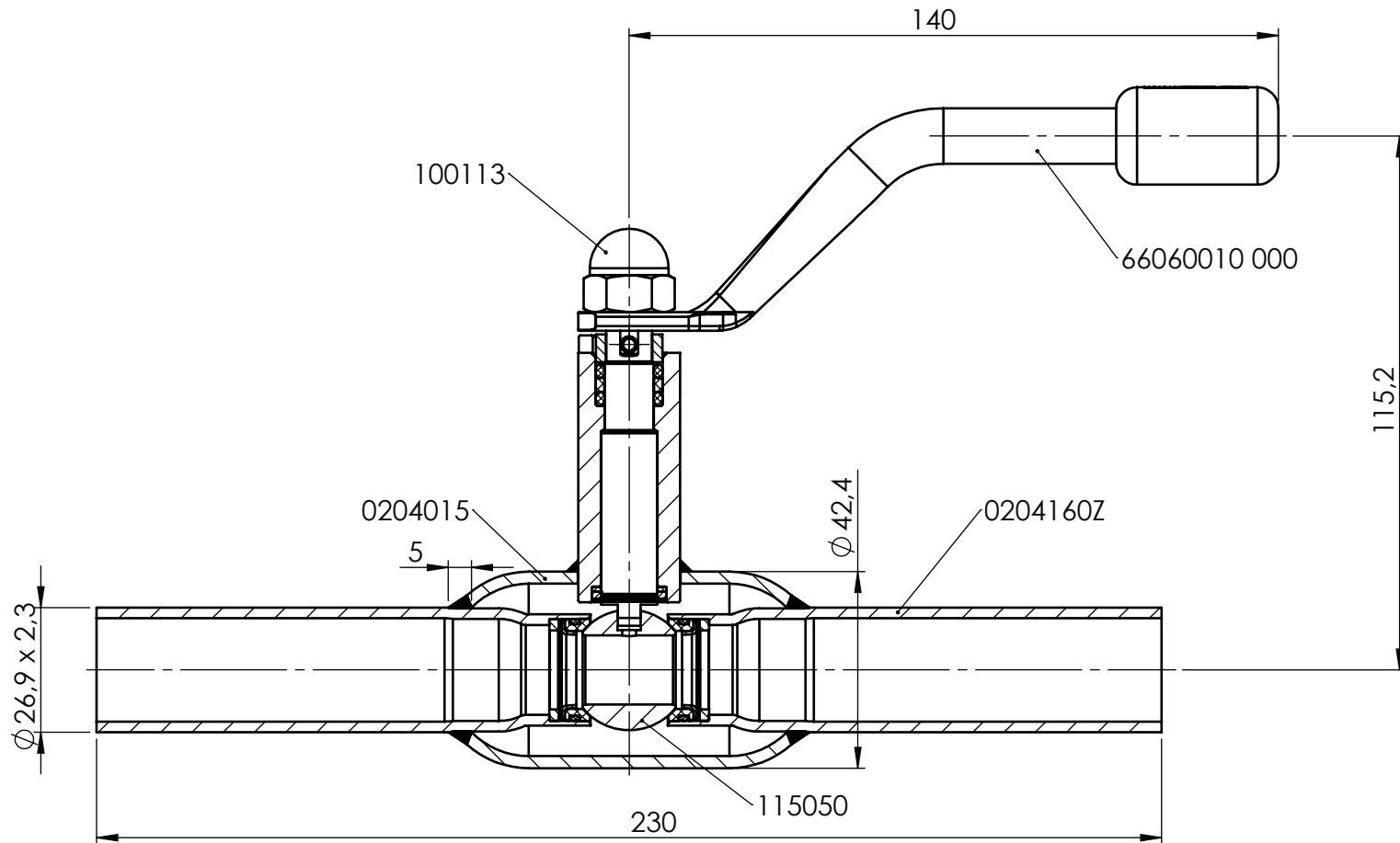

		00			
QDA	DCN	REV.	BEFORE CHANGE	DATE	BY
BROEN INTELLIGENT FLOW SOLUTIONS	MATERIAL			WEIGHT (g) 774.45	SCALE 1:1.5
	PART	DN020 W/W PN40		DRAW. PSA	DATE 26-02-2006
UNSPECIFIED TOLERANCES ANGLES ± 2° OTHER DIM. ± 0.2	PRODUCT	BALLOMAX GAS VALVE		APPR. JJA	DATE 15-02-2019
	CONNECTIONS	KUREK DN020 WSP PN40 GAZ		DRAWING NUMBER 7410240020	
This drawing is our property and may not be transferred to third party, copied or made use of without our permission.				SP no.:	Sheet 1 of 1

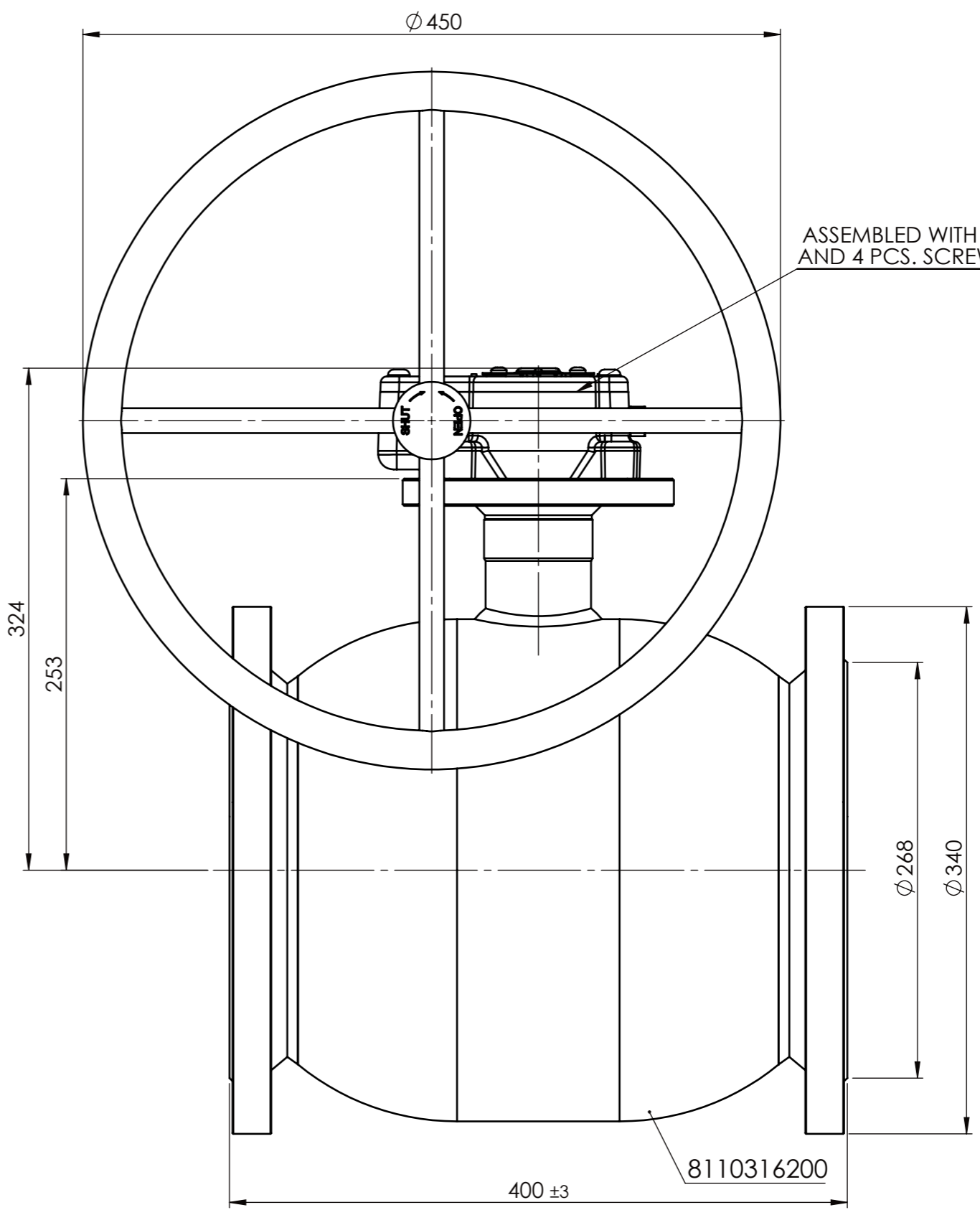
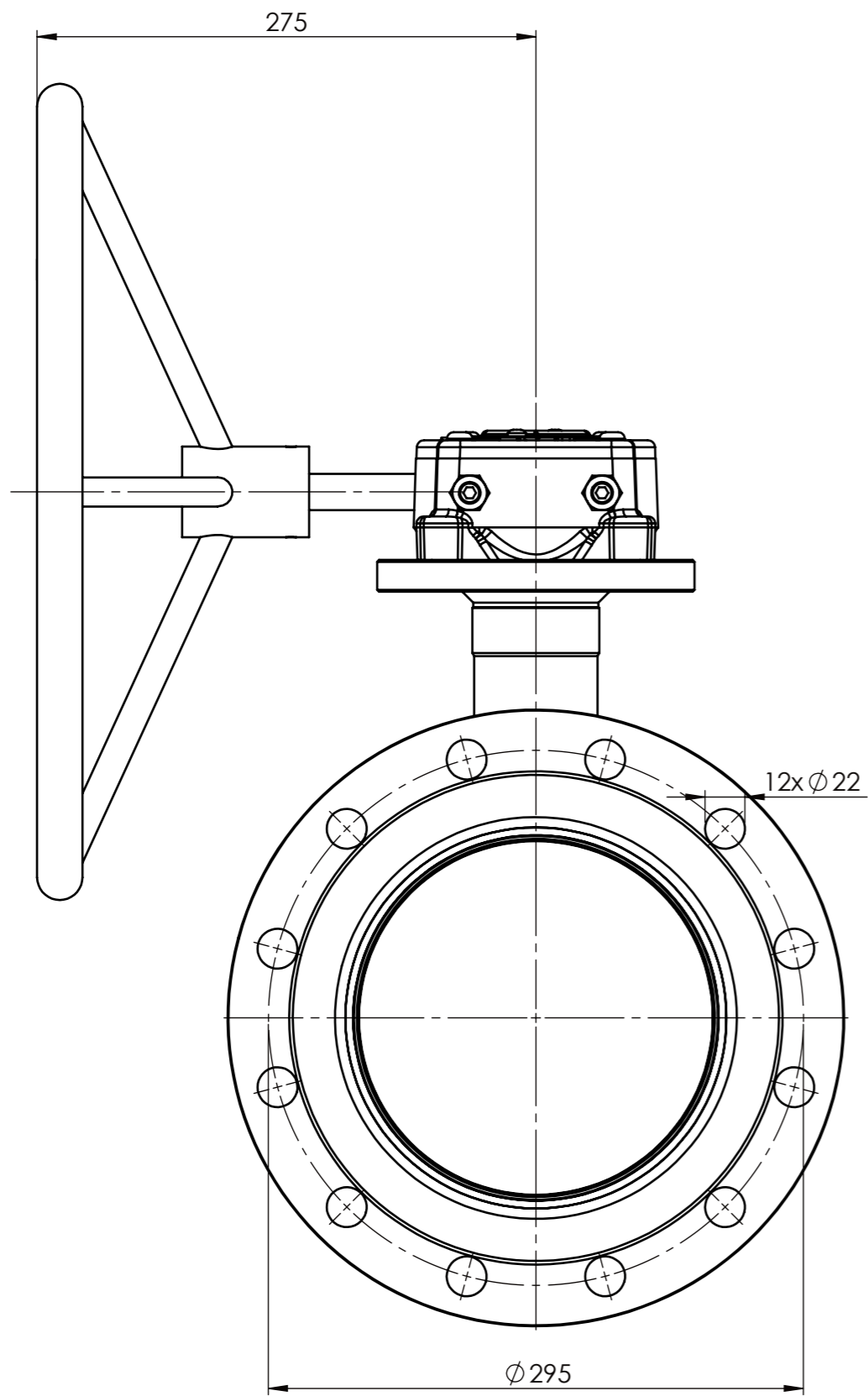

ASSEMBLED WITH ROTORK GEAR 600587
AND 4 PCS. SCREWS M16x30 0653 314 22

Geometric tolerance after ISO 14638

QDA		DCN		00	REV.	CHANGE	DATE		BY
BROEN VALVE TECHNOLOGIES		MATERIAL				WEIGHT (g) 77889.31		SCALE	
		PART				DRAW. WLE		DATE 10-12-2018	
UNSPECIFIED TOLERANCES ANGLES ± 2° OTHER DIM. ± 0.2		PRODUCT				APPR. JJA		DATE 03-01-2019	
		CONNECTIONS				DRAWING NUMBER		8110316200 480	
This drawing is our property and may not be transferred to third party, copied or made use of without our permission.							SP no.:		Sheet 1 of 1

Geometric tolerances after ISO14638

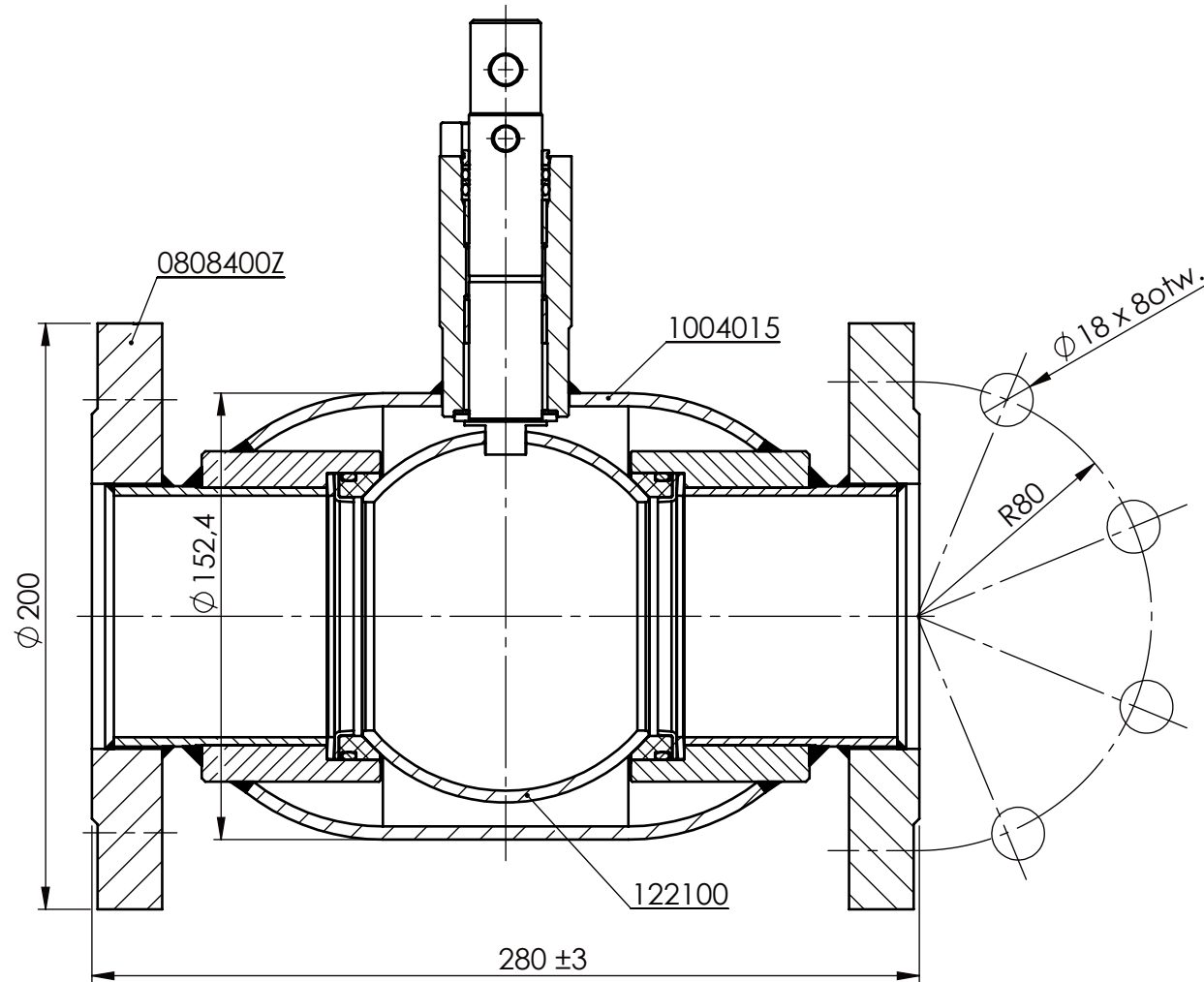

		00				
QDA	DCN	REV.	CHANGE		DATE	BY
BROEN VALVE TECHNOLOGIES	MATERIAL			WEIGHT (g) 18047.275		SCALE
	PART DN080 F/F PN25 MED FULL FLOW			DRAW. WLE	DATE 25-06-2010	1:2.5
UNSPECIFIED TOLERANCES ANGLES ± 2° OTHER DIM. ± 0.2	PRODUCT BALLOMAX GAS VALVE			APPR. JJA	DATE 03-04-2019	
	CONNECTIONS			DRAWING NUMBER 8410325080		
This drawing is our property and may not be transferred to third party, copied or made use of without our permission.				SP no.:	Arkusz1 of 1	