

GENERAL CATALOGUE

# MEDICAL LINE



**flow-meter™**  
ENGINEERING REVOLUTION IN MEDICAL TECHNOLOGY



**flow-meter™**  
ENGINEERING REVOLUTION IN MEDICAL TECHNOLOGY

oxygen therapy, suction of fluids  
pressure regulators and flowmeters, all medical gases  
flowmeter units, terminal units and accessories





Roberto Paratico | CEO

Increasingly **sophisticated technology** is working side by side with the hands and mind of the doctor, taking him or her every day towards goals once thought impossible and thus enabling human limits to be surpassed. But at the root of it all is the **knowledge, concentration, planning, inventiveness** and **imagination** of those who develop technology and of the doctors who use it, always pushing the boundaries of their possibilities with the aim of giving as much benefit as possible to the patient.

It is necessary to know, learn and experiment quickly, without ever compromising the quality of the clinical result. **flow-meter™** never stops at what already exists, but goes further.

**Knowing, designing, evolving.**  
That's **flow-meter™** method.



# flow-meter™





A RECOGNIZED AND RESPECTED "CENTER OF EXCELLENCE"

**flow-meter™** is active in the design and production of devices for measurement, control and supply of fluids, particularly for applications in the medical field.

During the years, the great experience conquered in Italy and abroad created the conditions to establish strict partnerships with some of the most prestigious Groups operating in the industry of the medical gases worldwide. This made **flow-meter™** as a recognized and respected "center of excellence" in this field.

The company's goal is headed to face with the complexity and the continuous technological evolution in the market of medical devices. This is possible only by investing in qualified human resources and developing related activities in design and technology. The strict respect of the medical field rules is absolute, receiving always from the Company management the maximum of attention.

## KEY POINTS

-  Year of establishment 1969
-  Levate, Bergamo
-  Total area of 21,000 sq metres  
indoor area of 5,000 sq metres
-  Europe, Asia - Pacific, Oceania,  
Middle East, Africa, Central  
and South America

# TABLE OF CONTENTS

The line of products dedicated to the field of devices for measurement, control and supply of medical gases in this catalogue is split into specific sections that show and regroup them according to their applications.

## OXYGEN THERAPY

flowmeters, reusable and single-patient humidifiers, pressure regulators, flow selectors and system for ambulances

## PRESSURE REGULATORS AND FLOWMETERS, ALL MEDICAL GASES

pressure regulators for cylinders and flowmeters

## TERMINAL UNITS

terminal units and components

## SUCTION OF FLUIDS

vacuum regulators, reusable and disposable containers for collection of organic liquids, venturi suction units, water manometers

## FLOWMETER UNITS

flowmeter devices, by-pass systems, high flow devices

## ACCESSORIES

rails, fixing devices, phleboclysis rods, jointed extension, low pressure hose assemblies





Manufacture, packaging and production times

# PRODUCTION

The components, manufactured **in-house or in outsourcing** by qualified subcontractors, support first accurate controls, then pass to the assembly, always made inside the factory, and finally the complete devices are subjected to a rigorous testing procedure before being released on the market.

**Careful packaging** and an **efficient shipping system** allow safe and quick delivery to customers and distributors worldwide.

The production times for orders fulfillment are **absolutely acceptable**, in application of the operational flexibility, one of the peculiarity of Italian industry excellences, well known and recognized all over the world.



# QUALITY

## QUALITY ASSURANCE SYSTEM

**flow-meter™** based its corporate structure on a main factor of strategic importance: the Quality.

In this regard, the Company has a Quality Assurance System certificated in accordance with:

- ISO 9001 : 2015 (Certificate No. 19026-A)
  - UNI EN ISO 13485 : 2021 (Certificate No. 19026-M)
- issued by notified body Company KIWA Cermet S.p.A.

## MEDICAL DEVICES

All medical devices manufactured by **flow-meter™** respect and comply the requirements of Regulation (EU) MDR 2017/745, and meet the technical specifications imposed by national and international reference standards.

Before getting the official release to the production, then to the market, the developed new devices support rigorous tests, carried out both in the internal laboratory, and in qualified external centers, in order to guarantee the full compliance of all products to the foreseen conditions of use.

For all medical devices manufactured by the Company, the process of **CE** marking is carried out by applying a complete quality system **EN ISO 13485**.



**flow-meter™** dedicates particular attention to the after sale service. A quick answer to clients comes always in few hours in case of any, rare, incident or not compliance, as well as the supply of spare parts or full technical assistance regarding the devices delivered to the customers. The standard warranty period of **flow-meter™** devices is 24 months. **flow-meter™** international view and perspective got the Company's distribution facilities to operate in a large number of Countries worldwide, both in areas known as modern and advanced in terms of quality of health services, and in areas experiencing strong growth in medical field.



**WORLDWIDE**

**Europe · Asia-Pacific · Oceania · Middle East  
Africa · Central and South America**

In those Countries where specific regulations are applied to allow the import of medical devices and where **flow-meter™** presented its products, the procedures for obtaining the registration and approval at the local Ministries of Health have never resulted in any problems.



# CERTIFICATIONS









The CE marking procedure is carried out according to the requirements of complete EN ISO 13485 quality system.





Before the production launch, all new **flow-meter™** products are subjected to rigorous tests, both in the company's own quality-assurance laboratories and by independent validated laboratories, to ensure that the products meet all the requirements of the medical professions in all foreseeable therapeutic conditions.

The changes in international legislation occurred in the hospital sector over the last few years and the introduction of managerial criteria in the public and private health care field, have highlighted the need to provide ongoing support for users of **flow-meter™** medical devices, before and after the sale. To be in line with these requirements, **flow-meter™** has activated

a **Customer Care Service**, to create and supply the procedures for monitoring and testing the equipment in order to guarantee the maximum functionality and efficiency during and after the installation. This service will also ensure a valid contribution in feedback from the market to improve the reliability and safety characteristics of **flow-meter™** medical devices.

# Products overview

OXYGEN THERAPY									
	EasyFLOW® VARIABLE AREA FLOWMETERS	Qmed® VARIABLE AREA OXYGEN FLOWMETERS	Rs VARIABLE AREA OXYGEN FLOWMETERS	EasyMED® PLUS CALIBRATED ORIFICES FLOWMETERS	EASYMED® CALIBRATED ORIFICES OXYGEN FLOWMETERS	DF FLOW SELECTOR FOR AEROSOL THERAPY	EasyCARE® PLUS PRESSURE REGULATORS	EASYCARE® PRESSURE REGULATORS	FM PRESSURE REGULATORS FOR OXYGEN THERAPY
	20	22	24	26	28	30	38	40	42

									
AV VENTURI SUCTION UNITS	VA - VD WATER MANOMETERS	EasySAFE® PLUS SAFETY JAR	EASYSAFE® SAFETY JAR	COLLECTION CONTAINERS FOR SMALL QUANTITY OF FLUIDS	JARS LARGE CAPACITY	FLOVAC® DISPOSABLE CONTAINERS	SUPPORTING DEVICES FOR COLLECTION JARS	SUCTION TROLLEY UNITS	CONNECTIONS AND ACCESSORIES
82	84	90	92	94	96	98	106	108	102

	TERMINAL UNITS			ACCESSORIES					
O <sub>2</sub> + FLUSH DEVICE	PRODUCT	TERMINAL UNITS	EN ISO 9170-2 AGSS TYPE 1 TERMINAL UNITS	PRODUCT	PROBES WITH THREAD CONNECTION	PROBES WITH HOSE CONNECTION	OUTLET DUPLICATORS	RAIL CLAMPING SYSTEMS AND WALL BRACKETS	JOINTED EXTENSIONS
136	PAGE	140	148	PAGE	154	155	156	157	159

## Accessories for oxygen therapy devices

Oxygen probes with thread connection	55
Oxygen probes with hose connection	56
Flowmeter outlet hose connection	56
Rail clamping systems for oxygen flowmeters	57
Cylinder inlet connections for oxygen pressure regulators	57

## Accessories for suction devices

Vacuum probes with thread connection	103
Vacuum probes with hose connection	104
Vacuum regulator outlet hose connection	104
Rail clamping systems	105
Wall brackets and stainless steel rail	105
Catheter containers	105

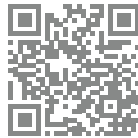

## FLOVAC® disposable containers

For any additional information, refer to the specific product catalogues.



					<b>SUCTION OF FLUIDS</b>				
<b>CH, TR, MAK</b> OXYGEN THERAPY HUMIDIFIERS	<b>EasyOX®</b> BUBBLING HUMIDIFIERS	<b>OXITER®</b> OXYGEN THERAPY SINGLE-PATIENT HUMIDIFIERS	<b>OXYGEN SUPPLY SYSTEMS</b> FOR AMBULANCES	<b>CONNECTIONS AND ACCESSORIES</b>	<b>PRODUCT</b>	<b>EasyVAC® PLUS DGT</b> DIGITAL VACUUM REGULATORS	<b>EasyVAC® PLUS</b> VACUUM REGULATORS	<b>EASYVAC®</b> VACUUM REGULATORS	<b>EasyAIR®</b> "VENTURI SYSTEM" SUCTION UNITS
<b>48</b>	<b>50</b>	<b>52</b>	<b>60</b>	<b>54</b>	<b>PAGE</b>	<b>70</b>	<b>72</b>	<b>74</b>	<b>80</b>

<b>PRESSURE REGULATORS AND FLOWMETERS, ALL MEDICAL GASES</b>				<b>FLOWMETER UNITS</b>					
<b>PRODUCT</b>	<b>FM</b> PRESSURE REGULATORS	<b>MU</b> PRESSURE REGULATORS	<b>Rs</b> VARIABLE AREA FLOWMETERS	<b>PRODUCT</b>	<b>FM</b> FLOWMETERS	<b>SF</b> FLOWMETERS	<b>EasyMIX®</b> OXYGEN/AIR MIXER	<b>EasyVEE®</b> FLOW DRIVER "JET"	<b>RM</b> FLOWMETERS
<b>PAGE</b>	<b>112</b>	<b>114</b>	<b>116</b>	<b>PAGE</b>	<b>120</b>	<b>122</b>	<b>124</b>	<b>128</b>	<b>134</b>

<b>PHLEBOCLYSIS RODS</b>	<b>LOW PRESSURE HOSE</b>	<b>HOSES FOR MEDICAL GASES</b>
<b>159</b>	<b>160</b>	<b>161</b>

### Diagram of options, matching:

flowmeters, connectors, humidifiers	<b>16</b>
pressure regulators, connections, humidifiers	<b>34</b>
vacuum regulators, connections, collection jars	<b>66</b>

### Diagram of options

oxygen supply system for ambulances	<b>58</b>
-------------------------------------	-----------

### Terminal Units - Components and directory

Terminal units	<b>140</b>
Components	<b>142</b>
Directory	<b>146</b>
EN ISO 9170-2 AGSS type 1	<b>148</b>
Components	<b>150</b>
Directory	<b>151</b>

### Accessories

Probes with thread connection	<b>154</b>
Probes with hose connection	<b>155</b>
Outlet duplicators	<b>156</b>
Rail clamping systems and wall brackets	<b>157</b>

The Jet device (Venturi unit) works as an high flow driver (booster) for high flow oxygen therapy through the use of HFNC or for CPAP, and it requires the gas supply from an Oxygen source only.

For more detailed information and composition diagrams, please read the dedicated page.

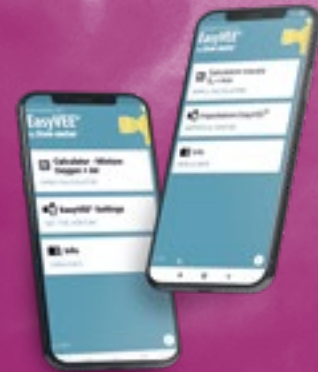

The App provides the healthcare professional with all guidelines to set the required flows for the ongoing respiratory therapy.

DOWNLOAD THE APP **EasyVEE®**



WE WORK EVERY DAY PROVIDING  
**A NEW WAY  
OF HEALTHCARE**

**EasyVEE®** is the new "jet" (Venturi) device manufactured by **flow-meter™**.

OXYGEN THERAPY



SUCTION OF FLUIDS



FLOWMETER UNITS



Down through the years, **flow-meter™** has built up its experience in the medical device industry, and during the same period has enhanced its sales performance, through the gradual technical development of its devices, by modifying, updating and improving its products, with an unfailing attention to market demand and feedback.

**To be revolutionary in engineering** you have to be able to offer the market new products evolving from existing ones, or to offer new technical solutions before the market even expresses a demand for them. **A revolution** can only take place in engineering if three guidelines are followed in the development of projects and their technical management:

1. the ability to be **innovative** at all times
2. the use of the best and most advanced manufacturing **technologies**
3. the constant application of **intelligent design** to obtain products endowed with a distinctive style and ergonomic forms which fully comply with safety requirements.

We have given a name to this way of thinking: **Easy**.

# OXYGEN THERAPY

DEVICES, ACCESSORIES &  
ASSEMBLY DIAGRAMS

FLOWMETERS, REUSABLE AND SINGLE-PATIENT HUMIDIFIERS,  
PRESSURE REGULATORS, FLOW SELECTORS  
AND SYSTEM FOR AMBULANCES

The line of **oxygen therapy** devices includes variable area flowmeters, calibrated holes "dial" flowmeters, pressure regulators with their cylinder connections, humidifiers, flow selectors and all the accessories to connect the devices to the oxygen and medical air supply sources in the hospital plants.

#### APPLICATIONS

The large range gives the possibility to select the best solution for the customer needs, allowing the creation of countless combinations meeting the various necessities of use.



hospitals



emergency



home care

The devices are manufactured in full compliance with the main technical regulations, as well as the requirements of Regulation (EU) MDR 2017/745. This allows to operate in complete and absolute safety, even in the most extreme conditions of use.

## DIAGRAM OF OPTIONS

# MATCHING FLOWMETERS, CONNECTORS, HUMIDIFIERS

<b>OXYGEN THERAPY</b>	■ OXYGEN THERAPY	<b>14</b>
1 <b>Easy</b> EasyFLOW® variable area oxygen flowmeter		20
2 Qmed® variable area oxygen flowmeter		22
3 Rs variable area oxygen flowmeter		24
4 <b>Easy</b> EasyMED® plus calibrated orifices oxygen flowmeter		26
5 EASYMED® calibrated orifices oxygen flowmeter		28
6 DF flow selector for aerosol therapy		30
7 Outlet hose connector, direct fitting		56
8 <b>Easy</b> EasyOX® bubbling humidifier		50
9 OXITER® oxygen therapy single-patient humidifier		52
10 CH/200 PC oxygen therapy humidifier		48
11 TR/200 PC (or PSU) oxygen therapy humidifier		48
12 MAK/300 PC oxygen therapy humidifier		48
13 MAK/500 PC oxygen therapy humidifier		48
<hr/>		
<b>CONNECTIONS AND ACCESSORIES FOR OXYGEN THERAPY DEVICES</b>		
<b>A OXYGEN PROBES WITH THREAD CONNECTION</b>	■ OXYGEN THERAPY	<b>55</b>
AFNOR NF-S 90-116 · AFNOR NF-S 90-116 EASYFIX® UNI 9507 · BS 5682 · DIN 13260 · SS 875 24 30 JIS T 7101 · SANS 1409 · OHMEDA		
<b>B OXYGEN PROBES WITH HOSE CONNECTION</b>	■ OXYGEN THERAPY	<b>56</b>
AFNOR NF-S 90-116 EASYFIX® · UNI 9507 BS 5682 · DIN 13260 · SS 875 24 30 · JIS T 7101 SANS 1409 · OHMEDA		
<b>C RAIL CLAMP BRACKET</b>	■ OXYGEN THERAPY	<b>57</b>
<hr/>		
<b>ACCESSORIES</b>		
<b>D</b> Hose for medical gas (oxygen)	■ ACCESSORIES	<b>161</b>

**A** OXYGEN PROBES  
WITH THREAD CONNECTION

**B** OXYGEN PROBES  
WITH HOSE CONNECTION



Easy

Easy

Easy



# FLOWMETERS

## Comparison - Main information

	p. 20 	p. 22	p. 24	p. 26 	p. 28
					
	EasyFLOW®	Qmed®	Rs	EasyMED® PLUS	EASYMED®
<b>TYPE</b>	variable area ball flowmeter	variable area ball flowmeter	variable area ball flowmeter	calibrated orifices	calibrated orifices
<b>MODE OF USE</b>	upright position	upright position	upright position	any position	any position
<b>PRESSURE</b>	non-compensated	compensated	compensated	non-compensated	non-compensated
<b>SCALE</b>	adjustable values	adjustable values	adjustable values	preset values	preset values
<b>OPTION</b>		L version - extended scale	L version - extended scale DF selector integrated in the body		
<b>BODY</b>	impact resistant polymer	anodized body version available in different colors	chrome plated brass body	impact resistant polymer	impact resistant polymer
<b>KNOB</b>	adjusting knob with soft grip with I/O switch button	ABS adjusting knob, color coded	ABS adjusting knob, color coded	adjusting knob with soft grip with I/O switch button	adjusting ergonomic knob
<b>PLUS</b>	lens effect of the tube push & lock system				
<b>OUTLET NIPPLE</b>	outlet nipple with double thread interchangeable by the end user	outlet nipple can be easily removed and replaced	fixed outlet nipple thread	outlet nipple with double thread interchangeable by the end user	fixed outlet nipple thread
					

# EasyFLOW®

Variable area oxygen flowmeters



Excellence in **INNOVATION**  
Breakthrough **TECHNOLOGY**  
Intelligent **DESIGN**

**EasyFLOW® flowmeters are instant flow variable area measurement devices for regulating the dosage of medical gases, particularly suitable in oxygen therapy.**

## STRUCTURE

They are manufactured with an integrated pressure reducer for the supplied pressure stabilization and with an outlet nipple having two connection threads on the two ends for an easy and quick interchangeability.

The body is made of impact-resistant polymer with brass chrome-plated fittings, while the precision needle valve having a large ergonomic control knob, a Push&Lock system to keep locked the preset flow value and Soft Grip inserts allows the operator to easily adjust the gas flow at the required value, depending on the kind of therapy.

In **EasyFLOW®** flowmeter the measurement tube has a lens effect to get the scale values easy reading in any condition of use.

## SIMPLE AND ACCURATE

The I/O switch button allows the operator to quickly lock and reactivate the flowmeter gas supply, keeping unchanged the previous flow preset value. The small size structure and the particular technical configuration allow the **EasyFLOW®** flowmeters to be able to supply flows of medical gas with extreme accuracy, even in the most difficult conditions, while the several options offered can satisfy any kind of use and exigencies.

## Main information



Both in single or twin flowmeter execution to allow double and separate gas flows by using a single medical gas supply.



The operators can get two options of outlet thread by simply reversing the nipple, depending on the required applications.

## Related products



**Humidifiers**  
from p. 47



**Oxygen Probes and Accessories**  
from p. 55

<b>SIZES (LxWxH)</b>	61x107x175 mm
<b>WEIGHT</b>	0.37 Kg
<b>GAS SUPPLY PRESSURE</b>	280 ÷ 600 kPa with an integrated pressure reducer for the stabilization of supplied pressure
<b>GASES OPTIONS</b>	O <sub>2</sub> · Air
<b>END OF SCALE VALUES</b>	5 L/min. · 10 L/min. · 15 L/min. · 30 L/min. · 40 L/min.
<b>ACCURACY</b>	±10% read value or ±0.5 L/min. if greater (±10% E.O.S. value for flow E.O.S. ≤ than 1 L/min.)
<b>STANDARD INLET CONNECTION</b>	ISO G 1/4" M. · 1/4" NPT M.
<b>STANDARD OUTLET CONNECTION</b>	Nipple with double thread, interchangeable by the end user: · M12x1.25 M - 1/4" ISO 3253 M. · 9/16" UNF EN 13544-2 M. - 1/4" ISO 3253 M. · M12x1.25 M. - 9/16" UNF EN 13544-2 M.
<b>FLOW CALIBRATION DATA</b>	1013 mbar 23 °C

- 1 **Graduate scale reading,** measurement tube with "lens effect".
- 2 **Adjusting knob** with Push&Lock System and Soft Grip inserts for easy handling.
- 3 **I/O switch.** Quick push switch button.
- 4 **Nipple** with double thread, interchangeable by the end user.



▶ WATCH THE VIDEO

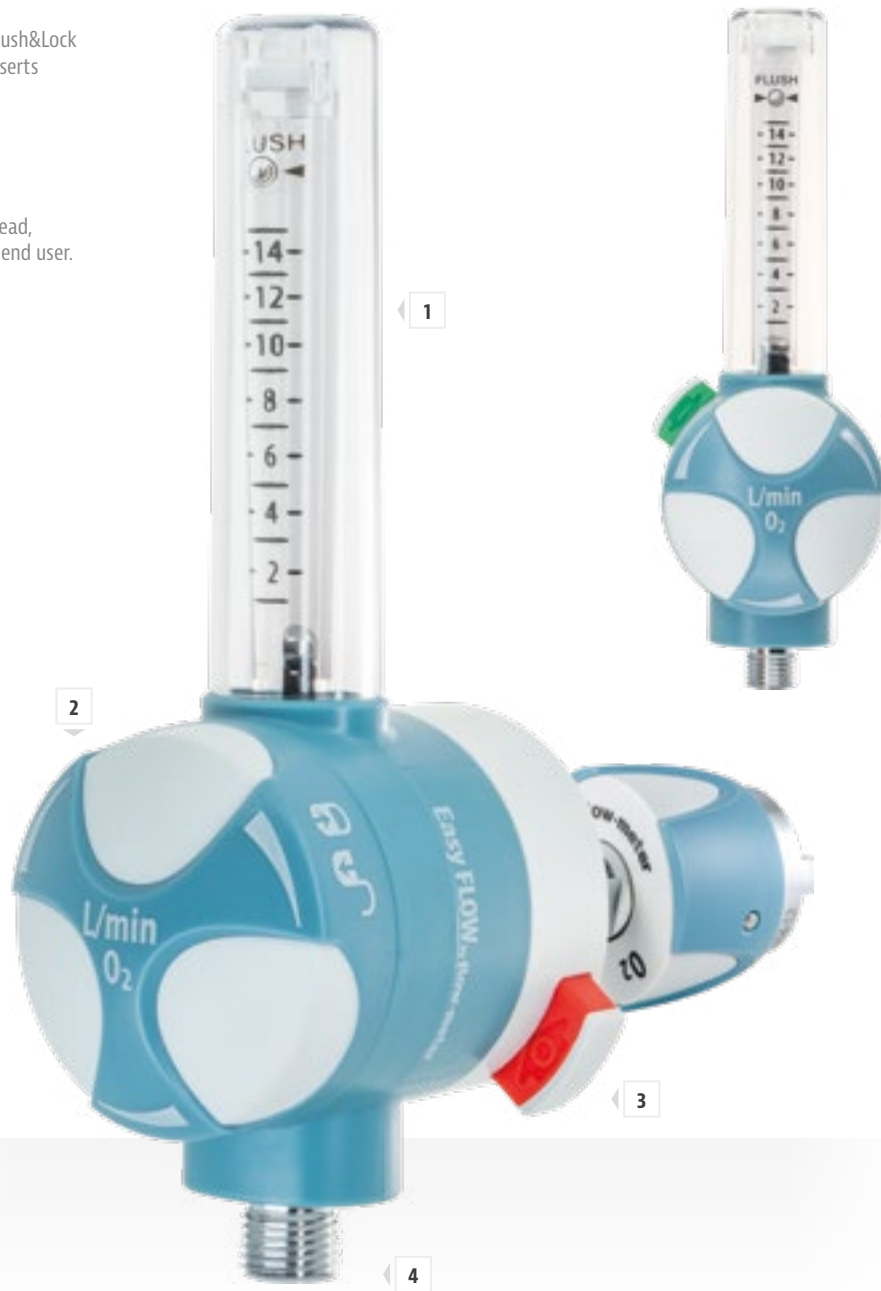

1



2



3



4

# Qmed®

Variable area **oxygen flowmeters**

**Qmed® flowmeters are instant flow measuring devices suitable for the dosage of medical gases. They are manufactured in version with compensated or not compensated pressure and in single or twin configuration in order to allow a double and independent gas supply using a single gas source.**

## STRUCTURE

The flowmeters type **Qmed®** fit a needle valve with a knob in color code for the immediate identification of the supplied gas. The body is made of aluminium making it extremely light and giving the possibility to obtain different finishing solutions such as chrome-plating or anodising, this last case in different customised colours.

The measure group is made of high resistance polycarbonate, a high mechanical resistance material that, together with the chrome-plated brass nipples and the aluminium body, makes this device ideal for the toughest applications. Moreover the outlet nipple can be easily manually removed and replaced by the operator, to meet any immediate application requirements.

## SOLUTIONS AND OPTIONS

The flowmeters type **Qmed®** are available in different solutions of pressure calibration and medical gases, various options of scale, normal or extended (L version) to allow a better reading of the indicated values and in several configurations of inlet and outlet connections offering a wide range of combinations to fit every application need.

## Main information



**Qmed®** can be manufactured in single or twin configuration in order to allow double and separate gas supply using a single gas source.



The outlet nipple can be easily manually removed and replaced by the operator, to meet any immediate application requirements.

## Related products



**Humidifiers**  
from p. 47



**Oxygen Probes and Accessories**  
from p. 55

**SIZES (LxWxH)** 82x33x142 mm

**WEIGHT** 0.15 Kg

**SUPPLY MAX. PRESSURE** 600 kPa

**STANDARD END OF SCALE VALUES - 400 kPa** 1 L/min. · 4 L/min. · 5 L/min. · 10 L/min. · 15 L/min. · 20 L/min. · 30 L/min. · 50 L/min.

**ACCURACY** ±10% read value or ±0.5 L/min. if greater (±10% E.O.S. value for flow E.O.S. ≤ than 1 L/min.)

**STANDARD INLET CONNECTION** ISO G 1/8" F. · ISO G 1/4" M. · 1/4" NPT M. · 3/8" ISO 3253 F. · M 12x1 F.

**STANDARD OUTLET CONNECTION** 1/4" ISO 3253 M. · 3/8" ISO 3253 M. · M 12x1.25 M. · 9/16" UNF EN 13544-2 M.

- 1 **Outlet connection** easy to remove and to replace.
- 2 **Anodized body version** available in different colours.



**Qmed® twin**  
chrome-plated aluminium body  
twin construction

**Qmed®**  
chrome-plated aluminium body  
single construction



1



2

# Rs

## Variable area oxygen flowmeters

**Rs flowmeters are instant flow measuring devices suitable for the dosage of medical gases, in this case oxygen and medical air. They can be produced in version with pressure compensated or not compensated, and manufactured both with single or twin flow tubes in order to allow a double and independent gas supply using a single gas source.**

### STRUCTURE

The flowmeters type **Rs** fit a needle valve with a knob in color code for the immediate identification of the supplied gas. The body is manufactured in chrome-plated brass with metal fittings. The measurement group is made of high resistance polycarbonate, making this device ideal for the toughest applications.

### SOLUTIONS AND OPTIONS

They are also available in different solutions of pressure calibration, various options of scale, normal or extended (L version) to allow a better reading of the indicated values. Several options are proposed concerning the threaded connections, inlet or outlet, offering an endless variety of combinations to meet all application requirements. The **Rs** flowmeter also offers the possibility to have a flow selector integrated in its body.

### Main information



**Rs** can be manufactured in single or twin configuration in order to allow double and separate gas supply using a single gas source.



The **Rs** flowmeter also offers the possibility to have a flow selector integrated in its body.

### Related products



**Humidifiers**  
from p. 47



**DF**  
flow selector  
p. 30



**Oxygen Probes and Accessories**  
from p. 55

	<b>Rs</b>	<b>Rs WITH INTEGRATED DF FLOW SELECTOR</b>
<b>SIZES (LxWxH)</b>	80x33x136 mm	82x55x180 mm
<b>WEIGHT</b>	0.24 Kg	0.38 Kg
<b>SUPPLY MAX. PRESSURE</b>	600 kPa	
<b>END OF SCALE VALUES - 350 kPa</b>	1 L/min. · 4 L/min. · 5 L/min. · 10 L/min. · 15 L/min. · 20 L/min. · 30 L/min. · 50 L/min.	
<b>ACCURACY</b>	±10% read value or ±0.5 L/min. if greater (±10% E.O.S. value for flow E.O.S. ≤ than 1 L/min.)	
<b>INLET CONNECTION</b>	ISO G 1/8" F. · ISO G 1/4" M. · 1/4" NPT M. · 3/8" ISO 3253 F. · M 12x1 F.	
<b>OUTLET CONNECTION</b>	1/4" ISO 3253 M. · 3/8" ISO 3253 M. · M 12x1.25 M. · 1/2" GAS M. 9/16" UNF EN 13544-2 M. · 1/2" BSF F.	

- 1 **Rs ABS knob**, oxygen color code.
- 2 **Rs flowmeter** with integrated DF flow selector.



**Rs twin**  
chrome-plated brass body  
twin construction

**Rs**  
chrome-plated brass body  
single construction



1



2

# EasyMED<sup>®</sup> PLUS

Calibrated orifices oxygen flowmeters



Excellence in **INNOVATION**  
Breakthrough **TECHNOLOGY**  
Intelligent **DESIGN**

**EasyMED<sup>®</sup> PLUS flowmeters are instant flow measurement devices with calibrated orifices for medical gases supply and dosage, particularly suitable in oxygen therapy. They are offered both in single or twin flowmeter execution to allow double and separate gas flow by using a single medical gas supply source.**

## STRUCTURE

The **EasyMED<sup>®</sup> PLUS** flowmeters are manufactured with an integrated pressure reducer for the supplied pressure stabilization and with an outlet nipple having two connection threads on the two ends for an easy and quick interchangeability. The operators can get two options of outlet thread by simply reversing the nipple, depending on the required applications. The body is made of impact-resistant polymer with brass chrome-plated fittings, while a large ergonomic control knob with Soft Grip inserts allows the operator to easily adjust the gas flow among the 10 possible preset options.

## SIMPLE AND ACCURATE

The calibration of the gas flow is ensured by orifices got on a metal support with the laser technology. The I/O switch button allows the operator to quickly lock and reactivate the flowmeter gas supply, keeping unchanged the previous flow preset value. The small size structure and the particular technical configuration allow the **EasyMED<sup>®</sup> PLUS** "dial" flowmeters to be able to supply flows of medical gas with extreme accuracy, even in the most difficult conditions, such as in emergency mobile units.

## Main information



**EasyMED<sup>®</sup> PLUS** can be manufactured in single or twin configuration in order to allow double and separate gas supply using a single gas source.



Compared to conventional variable area flowmeters having vertical indicator, they do not need to be always and only used in the upright position.

## Related products



**Humidifiers**  
from p. 47



**Oxygen Probes and Accessories**  
from p. 55

<b>SIZES (LxWxH)</b>	61x104x78 mm
<b>WEIGHT</b>	0.19 Kg
<b>GAS SUPPLY PRESSURE</b>	280 ÷ 600 kPa with an integrated pressure reducer for the stabilization of supplied pressure
<b>GASES OPTIONS</b>	O <sub>2</sub> · Air
<b>END OF SCALE VALUES</b>	6 L/min. · 14 L/min. · 15 L/min. · 30 L/min. · 50 L/min.
<b>ACCURACY</b>	±10% read value or ±0.5 L/min. if greater between 10% and 100% E.O.S. ±10% read value or ±0.2 L/min. if greater for flows < 10% E.O.S.
<b>STANDARD INLET CONNECTION</b>	ISO G 1/4" M. · 1/4" NPT M.
<b>STANDARD OUTLET CONNECTION</b>	Nipple with double thread, interchangeable by the end user: · M12x1.25 M - 1/4" ISO 3253 M. · 9/16" UNF EN 13544-2 M. - 1/4" ISO 3253 M. · M12x1.25 M - 9/16" UNF EN 13544-2 M.
<b>FLOW CALIBRATION DATA</b>	1013 mbar 23 °C
<b>FLOW RATES</b>	10 (0+9 preset values)

- 1 **Adjusting knob** with Soft Grip inserts for easy handling.
- 2 **I/O switch.** Quick push switch button.
- 3 **Nipple** with double thread, interchangeable by the end user.



▶ WATCH THE VIDEO



1



2



3

Regulation values for the different end of scale flows

		STEP VALUES									
END OF SCALES	<b>6 L/min.</b>	0.00	0.25	0.50	1.00	1.50	2.00	3.00	4.00	5.00	6.00
	<b>14 L/min.</b>	0.00	0.50	1.00	2.00	4.00	6.00	8.00	10.00	12.00	14.00
	<b>15 L/min.</b>	0.00	0.50	1.00	2.00	3.00	4.00	6.00	9.00	12.00	15.00
	<b>30 L/min.</b>	0.00	1.00	2.00	4.00	8.00	12.00	16.00	20.00	25.00	30.00
	<b>50 L/min.</b>	0.00	1.00	2.00	3.00	6.00	9.00	12.00	15.00	30.00	50.00

# EASYMED®

Calibrated orifices **oxygen flowmeters**

**EASYMED® flowmeters are top-quality instant flow measurement devices with calibrated orifices for regulating the dosage of oxygen and air in medical applications.**

## STRUCTURE

The flowmeters type **EASYMED®** are manufactured with an integrated pressure reducer for the supplied pressure stabilization and with the outlet fitting with thread adapted to the various required applications. The body is made of impact-resistant polymer with brass plated fittings, while a large ergonomic control knob allows an operator smooth drive for the selection of the gas supply value among the 10 possible options.

## WORKING PRINCIPLE

The calibration of the flow is ensured by orifices got on a metal support with the laser technology. The small size structure and the particular technical configuration allow the **EASYMED®** "dial" flowmeters to be able to supply flows of medical gas with extreme accuracy even in the most difficult conditions, such as in emergency mobile units.

## Main information



**EASYMED®** can be manufactured in single or twin configuration in order to allow double and separate gas supply using a single gas source.



Compared to conventional variable area flowmeters having vertical indicator, they do not need to be always and only used in the upright position.

## Related products



**Humidifiers**  
from p. 47



**Oxygen Probes and Accessories**  
from p. 55

<b>SIZES (LxWxH)</b>	82x54x65 mm
<b>WEIGHT</b>	0.12 Kg
<b>SUPPLY PRESSURE</b>	280÷600 kPa with integrated pressure regulator for the supplied pressure stabilization
<b>ACCURACY</b>	±10% read value or ±0.5 L/min. if greater between 10% and 100% E.O.S. ±10% read value or ±0.2 L/min. if greater for flows < 10% E.O.S.
<b>STANDARD SUPPLY CONNECTION</b>	ISO G 1/4" M. · 1/4" NPT M.
<b>STANDARD GAS OUTLET CONNECTION</b>	M12x1.25 M · 1/4" ISO 3253 M. · 3/8" ISO 3253 M. · 9/16" UNF EN 13544-2 M.
<b>GASES OPTIONS</b>	O <sub>2</sub> · Air
<b>STANDARD FULL SCALE FLOW RATE</b>	6 L/min. · 14 L/min. · 15 L/min. · 30 L/min. · 50 L/min.
<b>FLOW RATES</b>	10 (0+9 preset values)
<b>FLOW CALIBRATION DATA</b>	1013 mbar 23 °C

- 1 Ergonomic knob.
- 2 Flow indicator: easy and immediate reading; ten reading values, to improve low flows regulation.

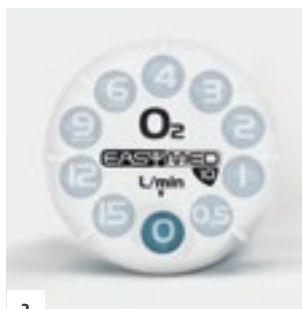
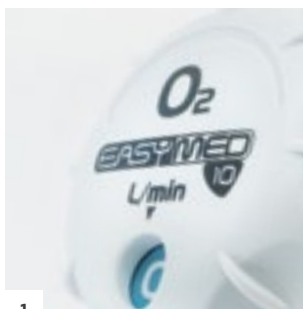

Regulation values for the different end of scale flows

		STEP VALUES									
END OF SCALES	6 L/min.	0.00	0.25	0.50	1.00	1.50	2.00	3.00	4.00	5.00	6.00
	14 L/min.	0.00	0.50	1.00	2.00	4.00	6.00	8.00	10.00	12.00	14.00
	15 L/min.	0.00	0.50	1.00	2.00	3.00	4.00	6.00	9.00	12.00	15.00
	30 L/min.	0.00	1.00	2.00	4.00	8.00	12.00	16.00	20.00	25.00	30.00
	50 L/min.	0.00	1.00	2.00	3.00	6.00	9.00	12.00	15.00	30.00	50.00

# DF

Flow selector for aerosol therapy

The DF flow selector, used in conjunction with Rs and Qmed® flowmeters, allows to divert the supplied gas through an humidifier or through a hose connector to connect devices used for aerosol therapy.

## STRUCTURE

The DF flow selector can be connected through its threaded ring to the flowmeter or supplied directly integrated in the Rs body. The flow can be easily directed to the humidifier for oxygen therapy, through the axial outlet, otherwise it can be diverted through a side hose connector for aerosol therapies.

## Main information



A synoptic printed on the body of the DF flow selector helps the operators to easily control the selected flow direction.

## Related products



**Rs**  
variable  
area oxygen  
flowmeters  
p. 24



**Qmed®**  
variable  
area oxygen  
flowmeters  
p. 22



**Humidifiers**  
from p. 47

<b>SIZES (LxWxH)</b>	32x54x69 mm
<b>WEIGHT</b>	0.16 Kg
<b>SUPPLY MAX. PRESSURE</b>	500 kPa
<b>MAX. PRESSURE DROP WITH FLOW 15 L/min. O<sub>2</sub></b>	9.20 kPa
<b>INLET CONNECTION</b>	1/4" ISO 3253 F. M12x1.25 F. · 9/16" UNF EN 13544-2 F.
<b>OUTLET CONNECTION</b>	1/4" ISO 3253 M. · M12x1.25 M. · 9/16" UNF EN 13544-2 M.
<b>HOSE CONNECTOR FOR AEROSOL CIRCUIT</b>	Ø 6÷9 mm
<b>PRESSURE DROP AT THE HUMIDIFIER SIDE WITH FLOW 20 L/min.</b>	17 kPa
<b>PRESSURE DROP AT THE AEROSOL SIDE WITH FLOW 20 L/min.</b>	34 kPa

- 1 **Connection to the flowmeters** with different threads.
- 2 **Connection to the humidifiers** with different threads.
- 3 **DF flow selector** integrated in the **Rs** flowmeter.



1



2

3





EasyMED® PLUS calibrated orifices  
oxygen flowmeters with EasyOX®  
bubbling humidifier

P. 26, 50



## DIAGRAM OF OPTIONS

# MATCHING PRESSURE REGULATORS, CONNECTIONS, HUMIDIFIERS

<b>OXYGEN THERAPY PRESSURE REGULATORS</b>		■ OXYGEN THERAPY	37
1	 <b>EasyCARE® plus</b> pressure regulator		38
2	<b>EASYCARE®</b> pressure regulator		40
3	<b>FM</b> pressure regulator for oxygen therapy		42
<b>OXYGEN THERAPY</b>		■ OXYGEN THERAPY	14
4	<b>Qmed®</b> variable area oxygen flowmeter		22
5	<b>Rs</b> variable area oxygen flowmeter		24
6	Flowmeter outlet hose connector		56
7	 <b>EasyOX®</b> bubbling humidifier		50
8	<b>OXITER®</b> oxygen therapy single-patient humidifier		52
9	<b>CH/200 PC</b> oxygen therapy humidifier		48
10	<b>TR/200 PC (or PSU)</b> oxygen therapy humidifier		48
11	<b>MAK/300 PC</b> oxygen therapy humidifier		48
12	<b>MAK/500 PC</b> oxygen therapy humidifier		48
<b>CONNECTIONS AND ACCESSORIES FOR OXYGEN THERAPY DEVICES</b>			
<b>E</b>	<b>CYLINDER INLET CONNECTIONS FOR OXYGEN PRESSURE REGULATORS</b>	■ OXYGEN THERAPY	57
	Pin Index EN 850 (or CGA 870) · AFNOR NF-E 29-656 DIN 477-1 · UNI 11144 · BS 341-3 · CGA 540		
<b>TERMINAL UNITS</b>			
<b>F</b>	<b>TERMINAL UNITS - COMPONENTS - OUTLETS</b>	■ TERMINAL UNITS	143
	AFNOR NF-S 90-116/NF-DS 90-119 · UNI 9507 NEO BS 5682 · DIN 13260 · SS 875 24 30		

**E** CYLINDER INLET CONNECTIONS  
FOR OXYGEN PRESSURE REGULATORS

**F** OUTLETS

Easy

1

2

4

5

3

CYLINDER INLET CONNECTIONS  
FOR OXYGEN PRESSURE REGULATORS

**E**

6



Easy

7

8

9

10

11

12



# PRESSURE REGULATORS

## Comparison - Main information

	p. 38	p. 40	p. 42
			
	<b>EasyCARE® PLUS</b>	<b>EASycare®</b>	<b>FM (with variable area flowmeter)</b>
<b>TYPE</b>	pressure regulator with calibrated orifices flowmeter	pressure regulator with calibrated orifices flowmeter	pressure regulator with variable area ball flowmeter
<b>MODE OF USE</b>	any position	any position	upright position
<b>SCALE</b>	preset values	preset values	adjustable values
<b>BODY</b>	brass and aluminium body with a techno-polymer shock proof shell	brass and aluminium body	brass body
<b>KNOB</b>	big size knob with soft grip inserts	adjusting ergonomic knob	ABS adjusting knob
<b>OUTLET NIPPLE</b>	outlet nipple with double thread interchangeable by the end user	fixed outlet nipple thread	fixed outlet nipple thread
<b>GAUGE</b>	gauge in tilted position with colored sections and double scale (bar/kPa + PSI)	gauge with colored sections and double scale (bar/kPa + PSI)	gauge with colored sections and double scale (bar/kPa + PSI)
			

# EasyCARE<sup>®</sup> PLUS

## Pressure regulators



Excellence in **INNOVATION**  
Breakthrough **TECHNOLOGY**  
Intelligent **DESIGN**

The EasyCARE<sup>®</sup> PLUS two stage pressure regulators are suitable for direct mounting on oxygen and medical air cylinders.

### STRUCTURE

Its structure is very compact and lightweight and it is particularly suitable for oxygen therapy. The body is made of brass and aluminium with an integrated calibrated orifices "dial" flowmeter having 10 preset medical gas flow options and it is housed inside a techno-polymer shock proof shell to protect the assembly, while a large ergonomic control knob with Soft Grip inserts allows the operator to easily adjust the gas flow between the 10 possible preset options. They are equipped with a preset overpressure safety valve, and can be supplied, as an option, with a terminal unit connected to the first stage chamber which allows to get an additional and separate source of medical gas. The outlet has a nipple with two connection threads on the two ends, for an easy and quick interchangeability.

### WORKING PRINCIPLE AND GAUGE

The pressure calibration of the individual stages is fixed and a pressure gauge, with easy reading colored sections, allows to get view continuously of the cylinder gas level, up to minimum allowed. A protective silicone cover and a techno-polymer support prevent gauge damages caused by possible shocks received during transport or use. The gauge in tilted position helps in reading even if the regulator is assembled on cylinders having small dimensions.

### Main information



The inlet connection is offered in several options, as per the different reference standards of the destination Countries.



The operators can get two options of outlet thread by simply reversing the nipple, depending on the required applications.



The small size structure and the particular technical configuration allow the EasyCARE<sup>®</sup> PLUS pressure regulators to supply flows of medical gases like oxygen with extreme accuracy, even in the most difficult conditions, such as in mobile units of emergency.

### Related products



Humidifiers  
from p. 47



Cylinder inlet connections  
p. 57

<b>SIZES (LxWxH)</b>	57x160x128 mm (with UNI 11144 cylinder connection and without optional terminal unit)
<b>WEIGHT</b>	0.75 Kg (without optional terminal unit)
<b>MAXIMUM GAS SUPPLY PRESSURE</b>	200 bar
<b>PRESSURE CONTROL GAUGE</b>	315 bar end of scale
<b>END OF SCALE STANDARD FLOW VALUES</b>	6 L/min. · 14 L/min. · 15 L/min. · 30 L/min. · 50 L/min.
<b>FLOW RATES</b>	10 (0+9 preset values)
<b>GASES OPTIONS</b>	O <sub>2</sub> · AIR
<b>DIAL FLOWMETER ACCURACY</b>	±10% read value or ±0.5 L/min. if greater between 10% and 100% E.O.S. ±10% read value or ±0.2 L/min. if greater for flows < 10% E.O.S.
<b>PRESSURE REDUCER ASSY</b>	double stage with shutter system
<b>FLOW SETTING DATA</b>	1013 mbar 23 °C
<b>INLET CYLINDER CONNECTIONS</b>	UNI 11144 · EN 850 · NF-E 29-656 · BS 341-3 · DIN 477-1 · ISO 5145 · CGA 540
<b>OUTLET CONNECTIONS</b>	Nipple with double thread, interchangeable by the end user: · M12x1.25 M. - 1/4" ISO 3253 M. · 9/16" UNF EN 13544-2 M. - 1/4" ISO 3253 M. · M12x1.25 M. - 9/16" UNF EN 13544-2 M.
<b>TERMINAL UNIT (OPTIONAL)</b>	AFNOR NF-S 90-116 · UNI 9507 · BS 5682 · DIN 13260 · SS 875 24 30
<b>SUPPLY PRESSURE</b>	360 ÷ 550 kPa (with cylinder pressure between 200 and 60 bar and constant flow of 40 L/min. 23 °C)

- 1 **Gauge** with easy reading colored sections to allow the continuous control of the cylinder gas level. Gauge fit in tilted position with colored sections and double scale (bar/kPa + PSI). **Protective silicone cover** and techno-polymer support.
- 2 **Big size knob**, with Soft Grip inserts for easy handling.
- 3 **Nipple** with double thread, interchangeable by the end user.
- 4 **Optional outlet**.

Being the integrated flowmeter a calibrated orifices type, there is no need to get it always and only used in the upright position, as required in case of use of pressure regulators fitting conventional variable area flowmeters with vertical reading values scales.

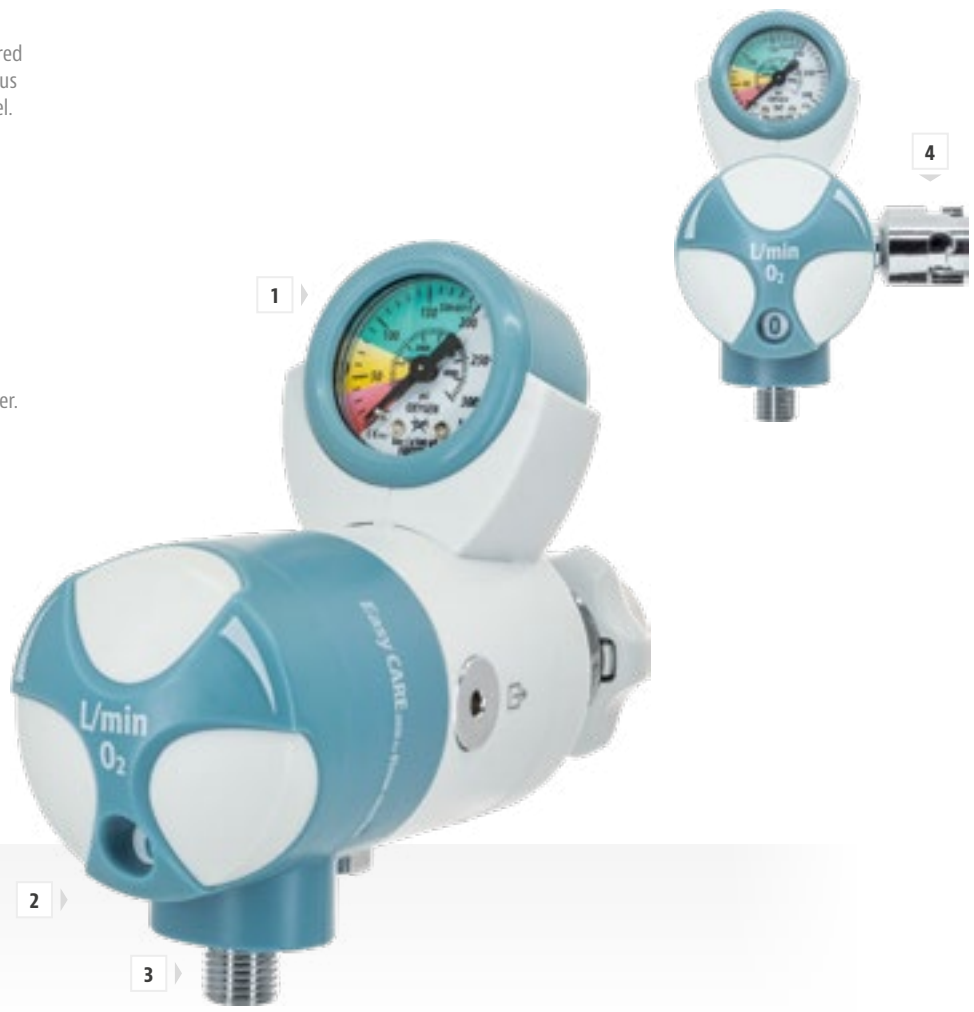

▶ WATCH THE VIDEO



1



2



3



4

### Regulation values for the different end of scale flows

		STEP VALUES									
END OF SCALES	6 L/min.	0.00	0.25	0.50	1.00	1.50	2.00	3.00	4.00	5.00	6.00
	14 L/min.	0.00	0.50	1.00	2.00	4.00	6.00	8.00	10.00	12.00	14.00
	15 L/min.	0.00	0.50	1.00	2.00	3.00	4.00	6.00	9.00	12.00	15.00
	30 L/min.	0.00	1.00	2.00	4.00	8.00	12.00	16.00	20.00	25.00	30.00
	50 L/min.	0.00	1.00	2.00	3.00	6.00	9.00	12.00	15.00	30.00	50.00

# EASYCARE®

## Pressure regulators

The EASYCARE® two stage pressure regulator is suitable for direct mounting on oxygen cylinders.

### STRUCTURE

Its structure is very compact and lightweight and it is particularly suitable for oxygen therapy. The body is made of brass and chrome-plated aluminum with an integrated impact resistant polymer calibrated orifices flowmeter with 10 options of flow oxygen supply. It is equipped with a pre-calibrated overpressure safety valve, and with a terminal unit (optional) connected to the first stage chamber which allows to get an additional and separate source of oxygen or air supplied at 4 bar. The inlet connection is offered in several options, as per the different reference standards of the destination Countries, and the outlet too is available with threads adapted to different applications.

### WORKING PRINCIPLE AND GAUGE

The pressure calibration of the individual stages is fixed and a pressure gauge allows to get view of the cylinder contents. A protective silicone cover prevents gauge damages caused by possible shocks received during transport or use.

### Main information



The inlet connection is offered in several options, as per the different reference standards of the destination Countries.



The small size structure and the particular technical configuration allow the EASYCARE® pressure reducers to get flows of medical gases like oxygen dispensed with extreme accuracy, even in the most difficult conditions, such as in mobile units of emergency.

### Related products



Humidifiers  
from p. 47



Cylinder inlet  
connections  
p. 57

<b>SIZES (LxWxH)</b>	147x55x117 mm (with UNI 11144 cylinder connection and without optional terminal unit)
<b>WEIGHT</b>	0.81 Kg (without optional outlet)
<b>MAXIMUM INLET PRESSURE</b>	200 bar
<b>GASES OPTIONS</b>	O <sub>2</sub> · AIR
<b>STANDARD FLOW RANGE</b>	6 L/min. · 14 L/min. · 15 L/min. · 30 L/min. · 50 L/min.
<b>FLOW RATES</b>	10 (0+9 preset values)
<b>FLOWMETER ACCURACY</b>	±10% read value or ±0.5 L/min. if greater between 10% and 100% E.O.S. ±10% read value or ±0.2 L/min. if greater for flows < 10% E.O.S.
<b>INLET CONNECTION TO THE CYLINDER</b>	UNI 11144 · EN 850 · NF-E 29-656 · BS 341-3 · DIN 477-1 · ISO 5145 · CGA 540
<b>OUTLET CONNECTION</b>	1/4" ISO 3253 M. · 3/8" ISO 3253 M. · M12x1.25 M. · 9/16" UNF EN 13544-2 M.
<b>TERMINAL UNIT (OPTIONAL)</b>	AFNOR NF-S 90-116 · UNI 9507 · BS 5682 · DIN 13260 · SS 875 24 30

- 1 Gauge with colored sections and double scale.
- 2 Easy reading of the O<sub>2</sub> flow; ten reading values to improve low flows regulation.
- 3 Ergonomic knob.
- 4 Detail of optional outlet.

In fact, being the integrated flowmeter a calibrated orifices type, there is no need to get it always and only used in the upright position, as required in case of use of pressure regulator fitting conventional variable area flowmeters with vertical indicator.

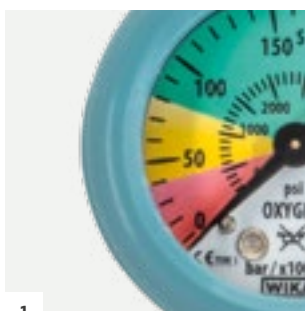

1

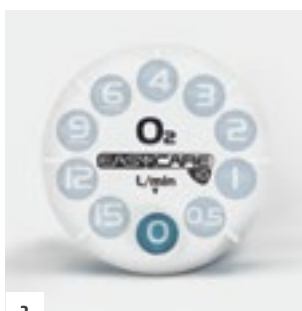

2



3



4

### Regulation values for the different end of scale flows

		STEP VALUES									
END OF SCALES	6 L/min.	0.00	0.25	0.50	1.00	1.50	2.00	3.00	4.00	5.00	6.00
	14 L/min.	0.00	0.50	1.00	2.00	4.00	6.00	8.00	10.00	12.00	14.00
	15 L/min.	0.00	0.50	1.00	2.00	3.00	4.00	6.00	9.00	12.00	15.00
	30 L/min.	0.00	1.00	2.00	4.00	8.00	12.00	16.00	20.00	25.00	30.00
	50 L/min.	0.00	1.00	2.00	3.00	6.00	9.00	12.00	15.00	30.00	50.00

# FM

Pressure regulators for **oxygen therapy**

**The single-stage FM pressure regulators, in their application in oxygen, are suitable for direct mounting on oxygen cylinders.**

## STRUCTURE

The **FM** pressure regulators are supplied with oxygen cylinder connections, among those available, according to the different reference standards of the destination Countries. They have a direct connection to a **Rs** and **Qmed** series variable area flowmeters, available in some options regarding the scale reading values and the outlet threads, suitable to connect a humidifier or a simple hose connector. The **FM** pressure regulators are designed for use with preset outlet pressure value. The structure and the fittings are in brass and the pressure relief valve is pre-calibrated, to guarantee protection in case of any system failure. A protective silicone cover prevents gauge damages caused by possible shocks received during transport or use.

## Main information



The structure and fittings are in brass.



The **FM** pressure regulator has an integrated variable area flowmeter and it must be only used in upright position.

## Related products



**Humidifiers**  
from p. 47



**Cylinder inlet connections**  
p. 57

	MAX. SIZES (LxWxH)	MAX. WEIGHT
<b>VERSION WITH HOSE CONNECTION ON OUTLET</b>	100x178x161 mm	1.24 Kg
<b>VERSION WITH HUMIDIFIER ON OUTLET</b>	108x180x320 mm	1.40 Kg
<b>MAXIMUM INLET PRESSURE</b>	200 bar	
<b>GASES OPTIONS</b>	O <sub>2</sub> · AIR	
<b>STANDARD FLOW RANGE</b>	5 L/min. · 10 L/min. · 15 L/min. · 30 L/min. · 50 L/min.	
<b>FLOWMETER ACCURACY</b>	±10% read value or ±0.5 L/min. if greater	
<b>INLET CONNECTIONS</b>	UNI 11144 · EN 850 · NF-E 29-656 · BS 341-3 · DIN 477-1 · ISO 5145 · CGA 540	
<b>FLOWMETER OUTLET CONNECTION</b>	1/4" ISO 3253 M · 3/8" ISO 3253 M · M12x1.25 M · 9/16" UNF EN 13544-2 M.	

- 1 Protective silicone cover. Gauge with colored sections and double scale.
- 2 Detail of **Rs** outlet thread connected to a humidifier.
- 3 Example of one of **many connections** to the cylinder.



1



2



3



EasyCARE® PLUS pressure regulator  
with EasyOX®  
bubbling humidifier



P. 38, 50





# HUMIDIFIERS

## Comparison - Main information

	p. 48	p. 48	p. 48	p. 50 	p. 52
					
	CH/200	TR/200	MAK/300&500	EasyOX®	OXITER®
MATERIAL	polycarbonate	polycarbonate polysulfone	polycarbonate	polycarbonate	polycarbonate and ABS
CAPACITY	210 ml	120 ml	MAK/300 285 ml MAK/500 355 ml	190 ml	285 ml
RELIEF VALVE	-	optional	optional	integrated	-
INLET & OUTLET	inlet nut and hose connector in brass	inlet nut and hose connector in brass	inlet nut and hose connector in brass	rotating nut with different snap inserts and 360° rolling positioning hose connector	hose connector and nut in ABS
					

OXYGEN THERAPY  
 SUCTION OF FLUIDS  
 PRESSURE REGULATORS  
 AND FLOWMETERS  
 ALL MEDICAL GASES  
 FLOWMETER UNITS  
 TERMINAL UNITS  
 ACCESSORIES

# CH, TR and MAK

Oxygen therapy humidifiers

The bubbling humidifiers for oxygen therapy series CH/200, TR/200, MAK/300 and MAK/500 are devices used to increase the relative humidity in the treatments with medical oxygen, both in hospital and at home.

## STRUCTURE

Humidifiers for oxygen series CH/200, TR/200, MAK/300 and MAK/500 are manufactured with both the transparent jar and the cover with bubbler in polycarbonate. All fittings are in brass and they can be sterilized in autoclave at 121 °C for 15 min. The model TR/200 can also be realized in PSU where higher value of sterilization temperature is requested (134 °C - 18 min.).

## OPTIONS AND CAPACITIES

The model TR/200, MAK/300 and MAK/500 can be equipped with an optional relief valve to avoid the possible over pressure inside the humidifier. They guarantee, in conjunction with flowmeters EasyFLOW®, Rs, Qmed®, EASYMED® and EasyMED® PLUS, an easy use and great versatility, combined with an extreme economy. They are supplied in different options of capacity (200 ml, 300 ml and 500 ml) and with optional threads in the input connections, this to satisfy the most varied requirements and needs.

## Main information



Medical oxygen, as it is normally supplied from hospital plant outlets or cylinders, has not a sufficient degree of humidity to be physiologically tolerated by the patient's airways without collateral consequences. Hence the need to add humidifiers on flowmeters' outlet for the humidification of the gas during dispensing.



The model TR/200, MAK/300 and MAK/500 can be equipped with an optional relief valve to avoid the possible over pressure inside the humidifier.

## Related products



Variable area and orifices calibrated oxygen flowmeters  
from p. 19



Pressure regulators  
from p. 37

	CH/200	TR/200	MAK/300	MAK/500
<b>INNER MAX. VOLUME</b>	210 ml	120 ml	285 ml	355 ml
<b>SIZES (LxWxH)</b>	55x67x200 mm	60x75x190 mm	70x81x175 mm	70x81x207 mm
<b>WEIGHT</b>	0.11 Kg	0.13 Kg	0.15 Kg	0.16 Kg
<b>MAX. APPLICABLE PRESSURE VALUE</b>	500 kPa			
<b>MAX. APPLICABLE FLOW VALUE</b>	10 L/min.			
<b>INLET CONNECTION</b>	1/4" ISO 3253 F. · 3/8" ISO 3253 F. · M 12x1.25 F. · 9/16" UNF EN 13544-2 F.			
<b>OUTLET CONNECTION</b>	hose connector Ø 6÷9 mm			
<b>RELIEF VALVE (OPTIONAL)</b>	preset at 80 kPa ±10% with a flow equal to 10 L/min.			

- 1 Detail of the **bubbling device**.
- 2 Detail of the **lid**.
- 3 Detail of the **relief valve** (optional).
- 4 The model **TR/200** can also be realized in PSU where higher value of sterilization temperature is requested.



# EasyOX<sup>®</sup>

Bubbling humidifiers

The bubbling humidifiers for oxygen therapy series EasyOX<sup>®</sup> are devices used to increase the relative humidity in the treatments with medical oxygen, both for hospital and homecare applications.

## STRUCTURE

The humidifiers for oxygen series EasyOX<sup>®</sup> are completely made of polycarbonate and they can be sterilized in autoclave at 121 °C for 15 min. The advanced design and the different options of snap threaded nut, allowing to fit the device in any situation, and the overall ergonomics make the humidifier EasyOX<sup>®</sup> particularly innovative. In conjunction with flowmeters EasyFLOW<sup>®</sup>, Rs, Qmed<sup>®</sup>, EASYMED<sup>®</sup> and EasyMED<sup>®</sup> PLUS, this humidifier guarantees operators an easy use and great versatility, combined with an extreme economy.



Excellence in **INNOVATION**  
Breakthrough **TECHNOLOGY**  
Intelligent **DESIGN**

## Main information



Medical oxygen, as it is normally supplied from hospital plant outlets or cylinders, has not a sufficient degree of humidity to be physiologically tolerated by the patient's airways without collateral consequences. Hence the need to add humidifiers on flowmeters' outlet for the humidification of the gas during dispensing.



The bottle hollow shape, besides being a design unique element, offers the operator an easy and safe handling and guarantees a higher humidification efficiency.

## Related products



Variable area and orifices calibrated oxygen flowmeters  
from p. 19



Pressure regulators  
from p. 37

<b>INNER MAXIMUM VOLUME</b>	190 ml
<b>SIZE (LxWxH)</b>	89x84x161 mm
<b>WEIGHT</b>	0.13 Kg
<b>MAXIMUM APPLICABLE PRESSURE VALUE</b>	80 kPa
<b>MAXIMUM APPLICABLE FLOW VALUE</b>	10 L/min.
<b>INLET CONNECTION</b>	9/16" UNF EN 13544-2 F. · 1/4" ISO 3253 F. M 12x1.25 F. · 3/8" ISO 3253 F.
<b>OUTLET CONNECTION</b>	hose connector Ø 6÷9 mm

- 1 **Snap nut, color coded** and provided with different connections threads to be chosen by the end user. Once inserted it cannot be removed.
- 2 **Opening by quick 1/12 turn** to facilitate the humidifier filling and cleaning procedures.
- 3 An ergonomic and big size **rotating nut** allows to easily connect and disconnect the humidifier **EasyOX®** to the oxygen supply device.
- 4 360° rolling positioning hose connector  $\varnothing$  6÷9 mm.
- 5 Detail of the **relief valve**.



▶ WATCH THE VIDEO



1



2

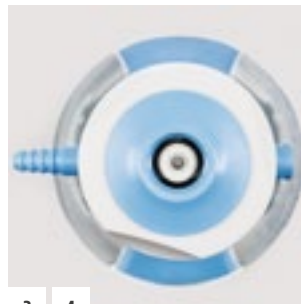

3

4



5

# OXITER®

Oxygen therapy single-patient humidifiers

The OXITER® bubbling humidifiers are single patient devices used to increase the relative humidity in the treatments with medical oxygen both in hospital and at home.

## STRUCTURE

The OXITER® single-patient bubbling humidifiers are made of a jar in polycarbonate and a cover and remaining structure in ABS. They are supplied in packs of 20 pieces.

The bubbling device guarantees the best supplied oxygen humidification, maintaining a noise level far below the limits of the reference standard (<50 dB at 1 m) and thus giving acceptable comfort to the patient, especially in prolonged respirators treatments. They guarantee, in conjunction with flowmeters EasyFLOW®, Rs, Qmed®, EASYMED® and EasyMED® PLUS, an easy use and great versatility, combined with an extreme economy.

## Main information



Medical oxygen, as it is normally supplied from hospital plant outlets or cylinders, has not a sufficient degree of humidity to be physiologically tolerated by the patient's airways without collateral consequences. Hence the need to add humidifiers on flowmeters' outlet for the humidification of the gas during dispensing.



This humidifier must be disposed at the end of the oxygen therapy treatment on a single patient.

## Related products



Variable area and orifices calibrated oxygen flowmeters  
from p. 19



Pressure regulators  
from p. 37

<b>INNER VOLUME</b>	285 ml
<b>SIZES (LxWxH)</b>	70x83x178 mm
<b>WEIGHT</b>	0.08 Kg
<b>MAX. APPLICABLE PRESSURE VALUE</b>	500 kPa
<b>MAX. APPLICABLE FLOW VALUE</b>	10 L/min.
<b>INLET CONNECTION</b>	1/4" ISO 3253 F. · 9/16" UNF EN 13544-2 F.
<b>OUTLET CONNECTION</b>	hose connector Ø 6÷9 mm
<b>HUMIDIFICATION POWER WITH OXYGEN SUPPLY (RELATIVE HUMIDITY AT 18.7 °C)</b>	
<b>INPUT</b>	14%
<b>OUTPUT</b>	89%
<b>AFTER 2 m TUBE Ø 5 mm WITH MASK</b>	73%

1 **Connections:** easy and intuitive; a color code highlights the match to different flowmeter outlet threads.

2 **Screw lid detail.**

3 Detail of the **bubbling device.**





# CONNECTIONS AND ACCESSORIES FOR OXYGEN THERAPY DEVICES

The flowmeters for oxygen therapy applications can be supplied completed with probes of our production for direct coupling into the terminal units. Otherwise, the pressure regulators are always supplied with special oxygen cylinder connections designed and made according to the various national and international standards. The oxygen flowmeter probes support frequent connections and detachments to the medical gas distribution systems, while the pressure regulators must guarantee perfect sealing and safety, when connected to the gas cylinders. The following pages contain main information regarding the available range of probes with thread connection and hose connection, for mounting on wall rails or floor stands. The pressure regulators cylinder connections too are available in the most popular standards. Detailed or specific solutions are available on request.

OXYGEN PROBES WITH THREAD AND HOSE CONNECTION, FLOWMETER OUTLET HOSE CONNECTION,  
RAIL CLAMPING SYSTEMS FOR OXYGEN FLOWMETERS, STAINLESS STEEL RAIL,  
CYLINDER INLET CONNECTIONS FOR OXYGEN PRESSURE REGULATORS

# Probes with thread connection



**AFNOR NF-S 90-116** probe, thread ISO G. 1/4" F.



**AFNOR NF-S 90-116 type EASYFIX®** probe, thread ISO G. 1/4" F.



**UNI 9507** probe, thread ISO G. 1/4" F.



**BS 5682** probe, thread ISO G. 1/4" F.



**DIN 13260** probe, thread ISO G. 1/4" F.



**SS 875 24 30** probe, thread ISO G. 1/8" M. or ISO G. 1/4" F.



**JIS T 7101** probe, thread ISO G. 1/8" M.



**SANS 1409** probe, thread ISO G. 1/4" F.



**OHMEDA** probe, thread ISO G. 1/4" F.

# Probes with hose connection

## Flowmeter outlet hose connection · Stainless steel rail

### Probes with hose connection



### Flowmeter outlet hose connection



### Stainless steel rail



# Rail clamping systems for oxygen flowmeters

## Cylinder inlet connections for oxygen pressure regulators

### Rail clamping systems



ABS clamp bracket for rail 30x10 mm and 50x10 mm, with nipple threaded ISO G. 1/4" F. and hose connector Ø 6 mm.

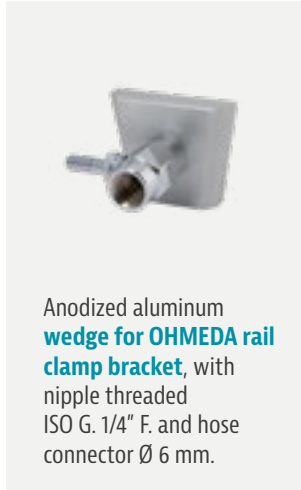

Anodized aluminum wedge for OHMEDA rail clamp bracket, with nipple threaded ISO G. 1/4" F. and hose connector Ø 6 mm.

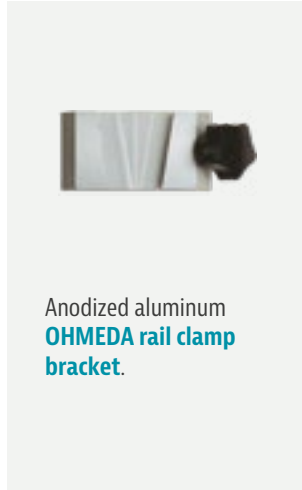

Anodized aluminum OHMEDA rail clamp bracket.

### Cylinder inlet connections for oxygen pressure regulators



EN 850 (or CGA 870) "pin-index" yoke cylinder connection.



AFNOR NF-E 29-656 cylinder connection.



DIN 477-1 cylinder connection.



UNI 11144 cylinder connection.



BS 341-3 "bull nose" cylinder connection.



CGA 540 cylinder connection.



# DIAGRAM OF OPTIONS

## OXYGEN SUPPLY SYSTEM FOR AMBULANCES

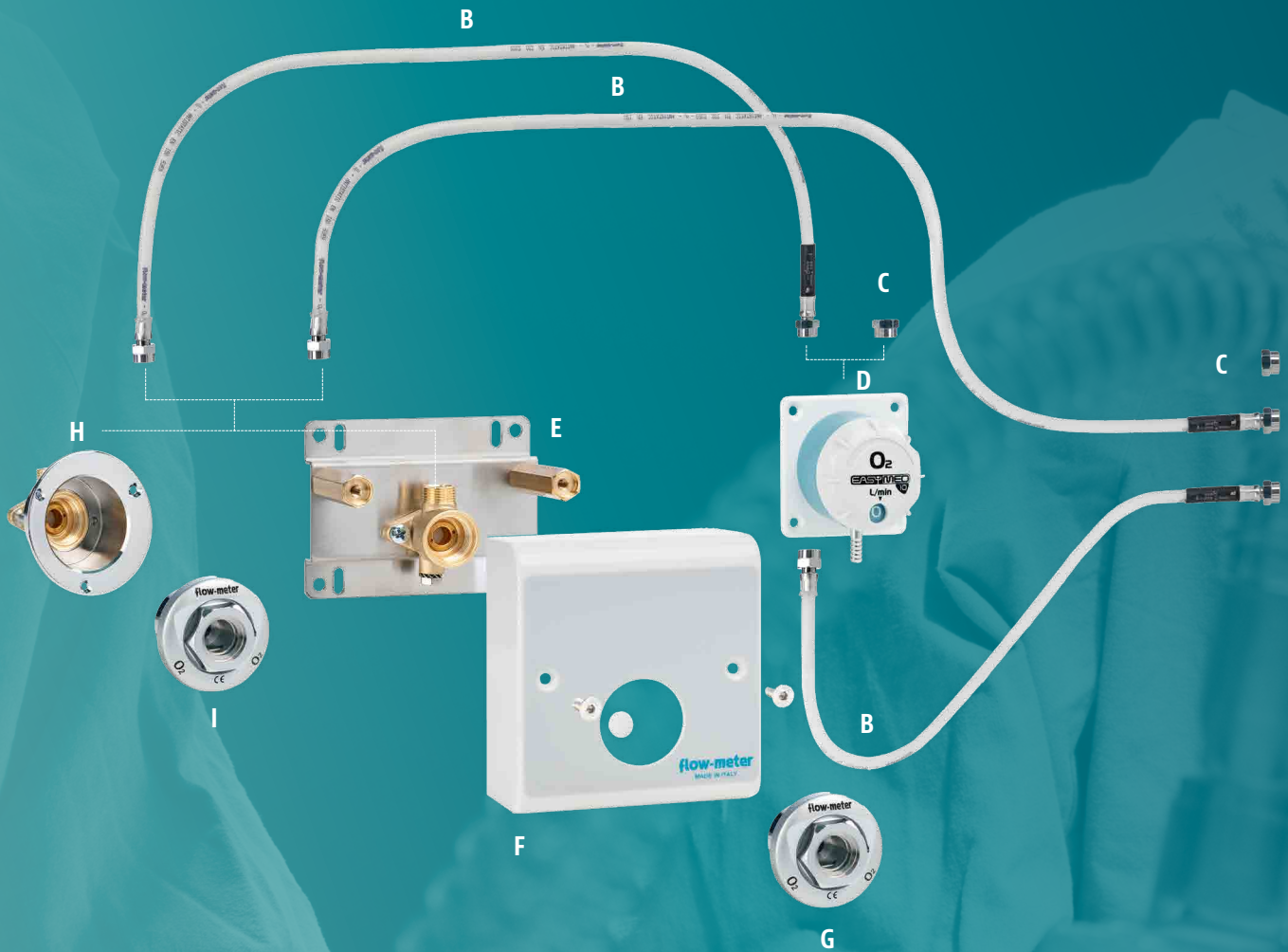

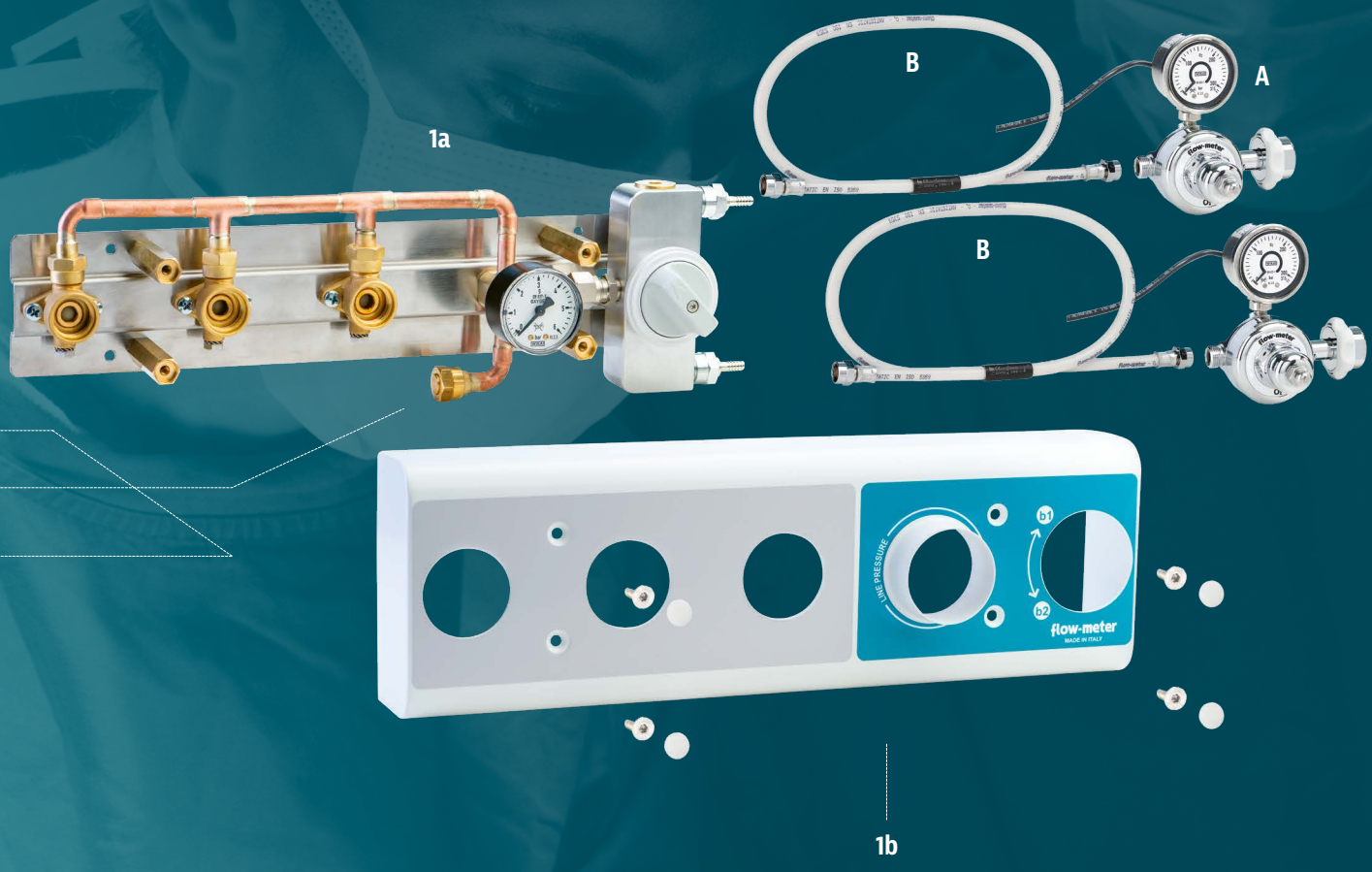

OXYGEN SUPPLY SYSTEM FOR AMBULANCES		OXYGEN THERAPY	58
1a	Oxygen terminal units system for ambulances		60
1b	Stainless steel cover panel		60

CONNECTION AND ACCESSORIES FOR OXYGEN SUPPLY SYSTEM FOR AMBULANCES			
A	FM pressure regulator with electrical signal	■ OXYGEN THERAPY	62-112
B	Low pressure hose for oxygen system for ambulances	■ ACCESSORIES	63
C	Plug to close the system (already supplied with the device)	■ OXYGEN THERAPY	-
D	EASYMED® calibrated orifices oxygen flowmeter with panel for ambulances	■ OXYGEN THERAPY	62
E	Socket for oxygen terminal unit	■ TERMINAL UNITS	63
F	Surface mounted case with stainless steel cover panel one position	■ TERMINAL UNITS	62
G	Oxygen outlet	■ TERMINAL UNITS	63-143
H	Socket with nut for panel mounting	■ TERMINAL UNITS	63-144
I	Oxygen outlet	■ TERMINAL UNITS	63-143

# Oxygen supply systems for ambulances

The oxygen supply systems in ambulances allow the oxygen distribution through terminal units, granting moreover the connection to mobile sources, such as medical gases cylinders, by means of suitable pressure regulators.

## Main information

Different devices necessary for ventilation therapies or for general medical applications and fitted with proper quick probes can be connected to the terminal units, available in different standards.

### OPTION AND STRUCTURE

They are available in configurations of one, two or three terminal units and with 2 inlets for the connection to the cylinders that can be activated separately by a selector.

The O<sub>2</sub> supply systems for ambulances mainly consist of:

- a stainless steel bottom support with holes for wall fixing;
- a selector enabling the operator to switch the supply source normally consisting in a medical gas cylinder fitted with pressure regulator;
- a copper pipe, bent and welded with cadmium free silver alloy. The copper pipe is a Class II A medical device, CE marked according to the current Regulation and following amendments and conforming to the specifications of the UNI EN 13348 standards;
- one or more oxygen terminal units. These terminal units are designed and manufactured according to the different standards and they are safe and simple to use for the operator. The terminal units are Class II B medical devices, CE marked according to current Regulation and following amendments and conforming to the specifications of the referenced standards;
- a gauge for the control of the line pressure, to grant the correct performance of the system and the oxygen supply continuity;
- two nipples with gas-specific threads to univocally connect the supply by means of low pressure hose assemblies properly banded and conforming to the specifications of UNI EN ISO 5359 standards (optional);
- a painted stainless steel cover panel with mounting fittings (optional).

<b>SIZES (LxWxH)</b>	1 terminal unit version:	87.5x270x130 mm
	2 terminal units version:	87.5x355x130 mm
	3 terminal units version:	87.5x440x130 mm
<b>WORKING PRESSURE</b>	4.0 bar ±20%	
<b>SUPPLY GAS</b>	oxygen	
<b>LINE PRESSURE CONTROL GAUGE</b>	end of scale 6.0 bar diam. 50 mm. Cl. 2.5	
<b>SUPPLY CONNECTIONS</b>	thread M16x1.25 M. (UNI 9507)	
<b>TERMINAL UNITS STANDARDS</b>	AFNOR NF-S 90-116 · UNI 9507 · BS 5682 · DIN 13260 · SS 875 24 30	

- 1 **Stainless steel bottom support** with holes for wall fixing.
- 2 **Nipples** with gas-specific threads to univocally connect the supply by means of low pressure hose assemblies properly banded and conforming to the specifications of UNI EN ISO 5359 standards (optional).

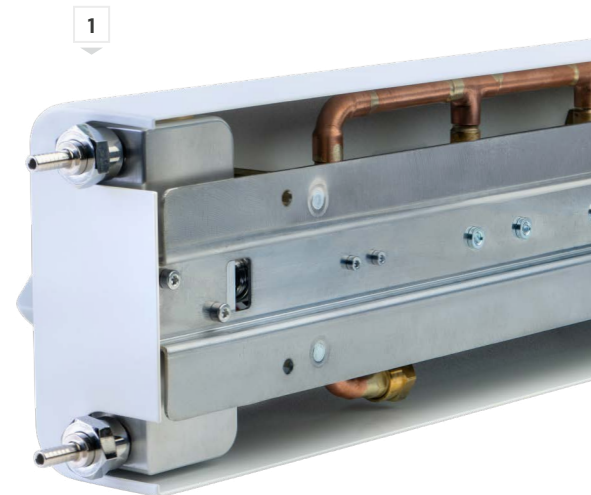

# Accessories

## FOR AMBULANCE SYSTEM



### FM - pressure regulator with special gauge for ambulances

A special version, made for ambulances applications, fits a pressure gauge with electric signal 4-20 mA or 0.5-4.5 V output for the continuous monitoring of the supplied pressure and with system control panel interface.

**GASES OPTIONS** Oxygen

**GAUGE ELECTRICAL FINAL** 4-20 mA or 0.5-4.5 V output

**OUTLET CONNECTOR** hose connector with gas specific rotating nut



Flow indicator: easy and immediate reading; ten reading values, to improve low flows regulation.

### EASYMED® - Calibrated orifices oxygen flowmeter

Calibrated orifices oxygen flowmeter complete with panel for ambulances supplied with mounting fittings. The flowmeter is manufactured with an integrated pressure reducer for the supplied pressure stabilization. It has also a flow indicator with 10 possible options and it is available with different end of scales.

#### Regulation values for the different end of scale flows

		STEP VALUES									
END OF SCALES	6 L/min.	0.00	0.25	0.50	1.00	1.50	2.00	3.00	4.00	5.00	6.00
	14 L/min.	0.00	0.50	1.00	2.00	4.00	6.00	8.00	10.00	12.00	14.00
	15 L/min.	0.00	0.50	1.00	2.00	3.00	4.00	6.00	9.00	12.00	15.00
	30 L/min.	0.00	1.00	2.00	4.00	8.00	12.00	16.00	20.00	25.00	30.00
	50 L/min.	0.00	1.00	2.00	3.00	6.00	9.00	12.00	15.00	30.00	50.00

### Surface mounted case

Surface mounted case with stainless steel cover panel one position for housing AFNOR NF-S 90-116, UNI 9507, DIN 13260, BS 5682, SS 875 24 30 outlets.

Technical details on p. 150.



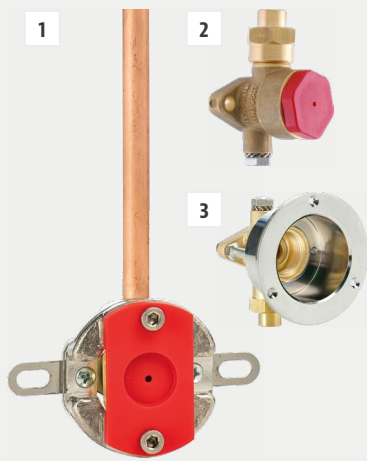

**Oxygen socket for:**

- 1 **DIN 13260, BS 5682, SS 875 24 30** outlets.
- 2 **AFNOR NF-S 90-116** and **UNI 9507** outlets with gas specific thread, complete with nut and copper welding tube nipple.
- 3 panel mounting with gas specific thread available for **AFNOR NF-S 90-116** and **UNI 9507** outlets only.

1



**Oxygen outlet type:**

- 1 **AFNOR NF-S 90-116** with gas specific thread UNI 9507
- 2 **UNI 9507** with gas specific thread UNI 9507
- 3 **DIN 13260**
- 4 **BS 5682**
- 5 **SS 875 24 30**

2



3



4



5



**Low pressure hoses for oxygen**

with gas specific connection to the ambulance system and available with following lengths:  
0.75 m - 1.5 m - 2.5 m - 6 m

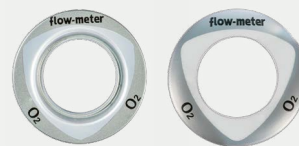

1

2

**Gas identification labels**

suitable for fitting on surface mounted case for:

- 1 **AFNOR NF-S 90-116**
- 2 **DIN 13260, BS 5682, SS 875 24 30**



# SUCTION OF FLUIDS

DEVICES, ACCESSORIES &  
ASSEMBLY DIAGRAMS

VACUUM REGULATORS, REUSABLE AND DISPOSABLE CONTAINERS  
FOR COLLECTION OF ORGANIC LIQUIDS, VENTURI SUCTION UNITS,  
WATER MANOMETERS

The range of devices with applications in **suction of fluids** includes: vacuum regulators devices to be connected to centralized vacuum systems, even with low scale for pediatric applications, and the matched fluid collection containers for small volumes, which also have function to protect the plant, the large fluid collection containers of various capacities, both reusable and disposable, the water manometers, the Venturi system suction devices, the trolley suction systems and all related accessories, connections and support containers systems.

#### APPLICATIONS

The wide line of products always allows to provide the best solution for client needs and the supply of countless combinations for the various requirements of use.



hospitals



emergency

#### ATTENTION TO HEALTH

The suction of body fluids requires special attention for protection of patients and health professionals to prevent viral and bacterial contamination. Safety is the key word in **flow-meter™** to guide the continuous devices development and the research for new solutions.



safety



research and development

All devices are manufactured in full compliance with the strict technical standards applied within the EU, and meet the requirements of the Regulation (EU) MDR 2017/745 in order to guarantee the use in complete and absolute safety, even in the most extreme conditions.

## DIAGRAM OF OPTIONS

# MATCHING VACUUM REGULATORS, CONNECTIONS, COLLECTION JARS

<b>SUCTION OF FLUIDS</b>		<b>SUCTION OF FLUIDS</b>	<b>64</b>
1	 <b>EasyVAC<sup>+</sup> PLUS DGT</b> vacuum regulator		70
2	 <b>EasyVAC<sup>®</sup> PLUS</b> vacuum regulator		72
3	<b>EASYVAC<sup>®</sup></b> vacuum regulator		74
4	 <b>EasyAIR<sup>®</sup></b> "Venturi system" suction unit		80
5	<b>AV/500</b> Venturi suction unit		82
6	<b>AV/1000</b> Venturi suction unit		82
7	<b>VA</b> water manometer		84
8	<b>VD</b> water manometer		84
9	 <b>EasySAFE<sup>®</sup> PLUS</b> safety jar		90
10	<b>EASYSAFE<sup>®</sup></b> PSU safety jar		92
11	<b>MAK/300</b> PC small volume collection jar		94
12	<b>MAK/500</b> PC small volume collection jar		94
13	<b>MAK/300</b> PC "Antibacteria" small volume collection jar		94
14	<b>MAK/500</b> PC "Antibacteria" small volume collection jar		94
15	Outlet hose connector, direct fitting		104
16	<b>MAK/2000</b> PC collection jar, direct fitting		96
17	<b>MAK/1000</b> PC collection jar, direct fitting		96
18	<b>MAK/4000</b> PC (or PSU) collection jar, pressure lid		96
19	<b>MAK/1000</b> PC (or PSU) collection jar, screw lid		96
20	<b>MAK/2000</b> PC (or PSU) collection jar, pressure lid (or screw lid)		96
21	<b>FLOVAC<sup>®</sup></b> disposable container		98
22	Support basket for <b>MAK/4000</b> collection jar		106
23	Support ring for <b>MAK/1000</b> collection jar		106
24	Support ring for <b>MAK/2000</b> collection jar		106
25	Support ring for <b>FLOVAC<sup>®</sup></b> disposable container		106
26	ON-OFF tap for <b>FLOVAC<sup>®</sup></b> disposable container support ring		-
27	Clip fixing 25x5 mm rings for trolleys, brackets and wall plates		106
<b>CONNECTIONS AND ACCESSORIES FOR SUCTION DEVICES</b>			
<b>A</b>	<b>VACUUM AND AIR PROBES WITH THREAD CONNECTION</b> AFNOR NF-S 90-116 · AFNOR NF-S 90-116 · EASYFIX <sup>®</sup> · UNI 9507 BS 5682 · DIN 13260 · SS 875 24 30 · JIS T 7101 · SANS 1409 · OHMEDA	<b>SUCTION OF FLUIDS</b>	<b>103-154</b>
<b>B</b>	<b>VACUUM AND AIR PROBES WITH HOSE CONNECTION</b> AFNOR NF-S 90-116 EASYFIX <sup>®</sup> · UNI 9507 · BS 5682 · DIN 13260 SS 875 24 30 · JIS T 7101 · SANS 1409 · OHMEDA	<b>SUCTION OF FLUIDS</b>	<b>104-155</b>
<b>C</b>	<b>RAIL CLAMPING SYSTEMS AND WALL BRACKETS</b>	<b>SUCTION OF FLUIDS</b>	<b>105</b>
<b>ACCESSORIES</b>		<b>ACCESSORIES</b>	<b>152</b>
<b>D</b>	Hose for medical gas (vacuum or medical air)		<b>161</b>





# VACUUM REGULATORS

## Comparison - Main information

	p. 70  	p. 72  	p. 74 
	EasyVAC® PLUS DGT	EasyVAC® PLUS	EASYVAC®
GAUGE	digital vacuum gauge with settable scale (mbar/hPa or mmHg)	standard control vacuum gauge with double scale (mbar/hPa or mmHg)	standard control vacuum gauge with double scale (mbar/hPa or mmHg)
TYPE	with membrane	with membrane	with membrane
KNOB	adjusting knob with Push&Lock system and soft grip inserts	adjusting knob with Push&Lock system and soft grip inserts	adjusting knob
ON/OFF	quick I/O push switch button	quick I/O push switch button	quick I/O push switch button
			

# EasyVAC<sup>®</sup> PLUS DGT

Digital vacuum regulators



Excellence in **INNOVATION**  
Breakthrough **TECHNOLOGY**  
Intelligent **DESIGN**

The EasyVAC<sup>®</sup> PLUS DGT continuous suction digital vacuum regulators range is suitable in all medical suction applications in hospitals and nursing homes.

## STRUCTURE

The device is made of a strong techno-polymer body, with a quick I/O switch button, a suction adjustment Soft Grip inserts knob for an easy handling with a "Push & Lock" position system and a digital vacuum control gauge with monochromatic LCD back-lighting display, available in three possible end-of-scale choices: -250 mbar, -600 mbar and -1000 mbar. A protective silicone cover and a techno-polymer support prevent gauge damages caused by possible shocks received during transport or use. The EasyVAC<sup>®</sup> PLUS DGT digital vacuum regulators are manufactured with outlet threaded connection for screwing in the usual collection containers for suctioned fluids, or for direct connection to the EasySAFE<sup>®</sup> PLUS safety jar, through a specific quick release integrated connection. The use of the EasySAFE<sup>®</sup> PLUS safety jar is highly recommended to get a complete suction device able to guarantee total protection of the vacuum regulator and plant.

## Main information



The digital vacuum gauge has a monochromatic LCD back-lighting display indicating the depression supplied value settable by the end users to be read in mbar/hPa or mmHg.



The frontal part of the digital gauge is equipped with 3 buttons: one to switch ON/OFF the EasyVAC<sup>®</sup> PLUS DGT, the other 2 for various settings.



The quick opening of the front cover facilitates the cleaning and maintenance procedures.

## Related products



Safety jars  
from p. 89



Collection jars  
from p. 96



Probes  
and Accessories  
from p. 103

	EasyVAC <sup>®</sup> PLUS DGT 250	EasyVAC <sup>®</sup> PLUS DGT 600	EasyVAC <sup>®</sup> PLUS DGT 1000
<b>SIZES (LxWxH)</b>	91x106x185 mm	91x106x185 mm	91x106x185 mm
<b>WEIGHT</b>	0.47 Kg	0.47 Kg	0.47 Kg
<b>MAXIMUM SUCTION FLOW</b>	50 L/min. ±5 L/min. at -220 mbar	72 L/min. ±5 L/min. at -550 mbar	105 L/min. ±5 L/min. at -950 mbar
<b>MAXIMUM AVAILABLE NEGATIVE PRESSURE EFFECTIVE VALUE</b>	-220 mbar ±20 mbar	-550 mbar ±20 mbar	-950 mbar
<b>OVER DEPRESSION PROTECTING VALVE</b>	preset with anti-clogging system	preset with anti-clogging system	N/A
<b>DIGITAL VACUUM GAUGE</b>	0 ÷ -250 mbar/hPa (0 ÷ -187 mmHg) numerical display of the vacuum value and a sector bar proportional to the adjusted de-pressure	0 ÷ -600 mbar/hPa (0 ÷ -450 mmHg)	0 ÷ -1000 mbar/hPa (0 ÷ -750 mmHg)
<b>SUCTION VALUE ADJUSTMENT SYSTEM</b>	with membrane		
<b>STANDARD INLET CONNECTION</b>	ISO G. 1/4" M		
<b>OUTLET CONNECTION</b>	ISO G. 1/2" M. + quick release system for EASYSAFE <sup>®</sup> or EasySAFE <sup>®</sup> PLUS safety jar connection		
<b>I/O SWITCH</b>	quick push switch button		
<b>READING RESOLUTION</b>	1 mbar/hPa (1 mmHg)		
<b>POWER SOURCE</b>	rechargeable lithium-ion battery 3.7V - 2040mAh		
<b>CONTROL BUTTONS</b>	ON/OFF and SETTINGS TO: <ul style="list-style-type: none"> <li>· select the unit scale (mbar/hPa or mmHg)</li> <li>· set the timer for the automatic switch off of the regulator</li> <li>· set up a warning at a specific vacuum value</li> <li>· fix the time of the back-lighting</li> <li>· zeroing the device at any time</li> </ul>		

- 1 **Digital vacuum gauge** with monochromatic LCD display and back-lighting to be activated by the operator
  - Scale settable in mbar/hPa or mmHg by the end user
  - Numerical display of the vacuum value and a sector bar proportional to the adjusted de-pressure
  - Reading resolution is 1 mbar/hPa (1 mmHg)
- 2 Charging and power supply port: **USB type C**.
- 3 **Buttons for ON/OFF** [ ⏻ ] and settings [ ▲▼ ]
- 4 Vacuum adjusting knob with **Push&Lock system** and **Soft Grip inserts** for easy handling. Quick I/O push switch-button.
- 5 De-pressure excess safety valve (for **EasyVAC® PLUS DGT 250** and **EasyVAC® PLUS DGT 600** only) with anti-clogging system.



▶ WATCH THE VIDEO



EasyVAC® PLUS DGT 250  
adjusted at -150 mbar



EasyVAC® PLUS DGT 600  
adjusted at -450 mbar



EasyVAC® PLUS DGT 1000  
adjusted at -600 mbar with **EasySAFE® PLUS**  
safety jar (optional)

EasySAFE® PLUS safety jar p. 90

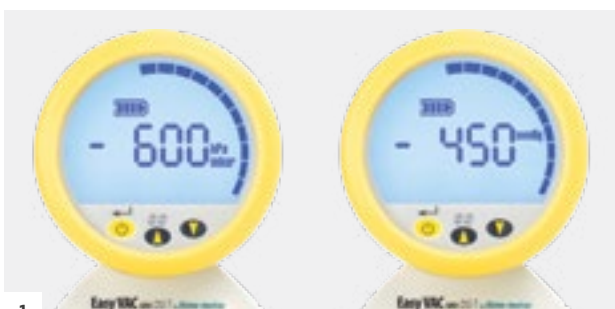

1

**ON/OFF and SETTINGS TO:**

- select the unit scale (mbar/hPa or mmHg)
- set the timer for the automatic switch off of the regulator
- set up a warning at a specific vacuum value
- fix the time of the back-lighting
- zeroing the device at any time



2



3

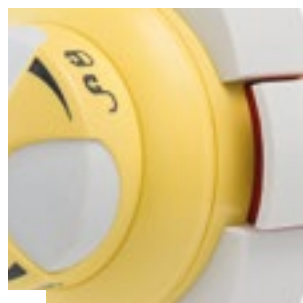

4



5

# EasyVAC® PLUS

Vacuum regulators



Excellence in **INNOVATION**  
Breakthrough **TECHNOLOGY**  
Intelligent **DESIGN**

The EasyVAC® PLUS continuous suction vacuum regulators range is suitable in all medical suction applications in hospitals and nursing homes.

## STRUCTURE

The device is made of a strong techno-polymer body, with a quick I/O switch button, a suction adjustment Soft Grip inserts knob for an easy handling with a "Push & Lock" position system and a vacuum control gauge with three possible end-of-scale choices: -250 mbar, -600 mbar and -1000 mbar. A protective silicone cover and a techno-polymer support prevent gauge damages caused by possible shocks received during transport or use. The EasyVAC® PLUS vacuum regulators are manufactured with outlet threaded connection for screwing in the usual collection containers for suctioned fluids, or for direct connection to the EasySAFE® PLUS safety jar, through a specific quick release integrated connection. The small sizes of the EasyVAC® PLUS vacuum regulators help in installing multiple sets of medical gas devices into the wall terminal units. The extreme rationality and simplicity, combined with the sophisticated technical execution, allow both operators and patients to appreciate the safety and reliability of this medical device.

## Main information



EasyVAC® PLUS has a vacuum control gauge with double scale and it is available in three possible end of scale choices.



The quick opening of the front cover facilitates the cleaning and maintenance procedures.

## Related products



Safety jars  
from p. 89



Collection jars  
from p. 96



Probes  
and Accessories  
from p. 103

	EasyVAC® PLUS 250	EasyVAC® PLUS 600	EasyVAC® PLUS 1000
<b>SIZES (LxWxH)</b>	91x106x185 mm		
<b>WEIGHT</b>	0.47 Kg	0.37 Kg	0.37 Kg
<b>MAXIMUM SUCTION FLOW</b>	50 L/min. ±5 L/min. at -220 mbar	72 L/min. ±5 L/min. at -550 mbar	105 L/min. ±5 L/min. at -950 mbar
<b>MAXIMUM AVAILABLE NEGATIVE PRESSURE EFFECTIVE VALUE</b>	-220 mbar ±20 mbar	-550 mbar ±20 mbar	-950 mbar
<b>OVER DEPRESSION PROTECTING VALVE</b>	preset with anti-clogging system	preset with anti-clogging system	N/A
<b>VACUUM GAUGE</b>	0 ÷ -250 mbar	0 ÷ -600 mbar	0 ÷ -1000 mbar
<b>MAX. DEPRESSION SUPPLY VALUE</b>	-950 mbar		
<b>SUCTION VALUE ADJUSTMENT SYSTEM</b>	with membrane		
<b>STANDARD INLET CONNECTION</b>	ISO G. 1/4" M		
<b>OUTLET CONNECTION</b>	ISO G. 1/2" M. + quick release system for EASYSAFE® or EasySAFE® PLUS safety jar connection		
<b>I/O SWITCH</b>	quick push switch button		

- 1 **Vacuum gauge** with colored sectors and double scale (mbar/hPa or mmHg), for easy reading of set vacuum values. Silicone cover and anti shock support.
- 2 **Quick I/O** push switch-button.
- 3 **Vacuum adjusting knob** with Push&Lock system and Soft Grip inserts for easy handling. Adjustment assembly **quick release cover** 1/12 turn.
- 4 De-pressure excess safety valve (for **EasyVAC® PLUS 250** and **EasyVAC® PLUS 600** only) with anti-clogging system.
- 5 ISO G. 1/2" M. + quick release system for **EasySAFE® plus** or **EASYSAFE®** safety jar connection.



▶ WATCH THE VIDEO

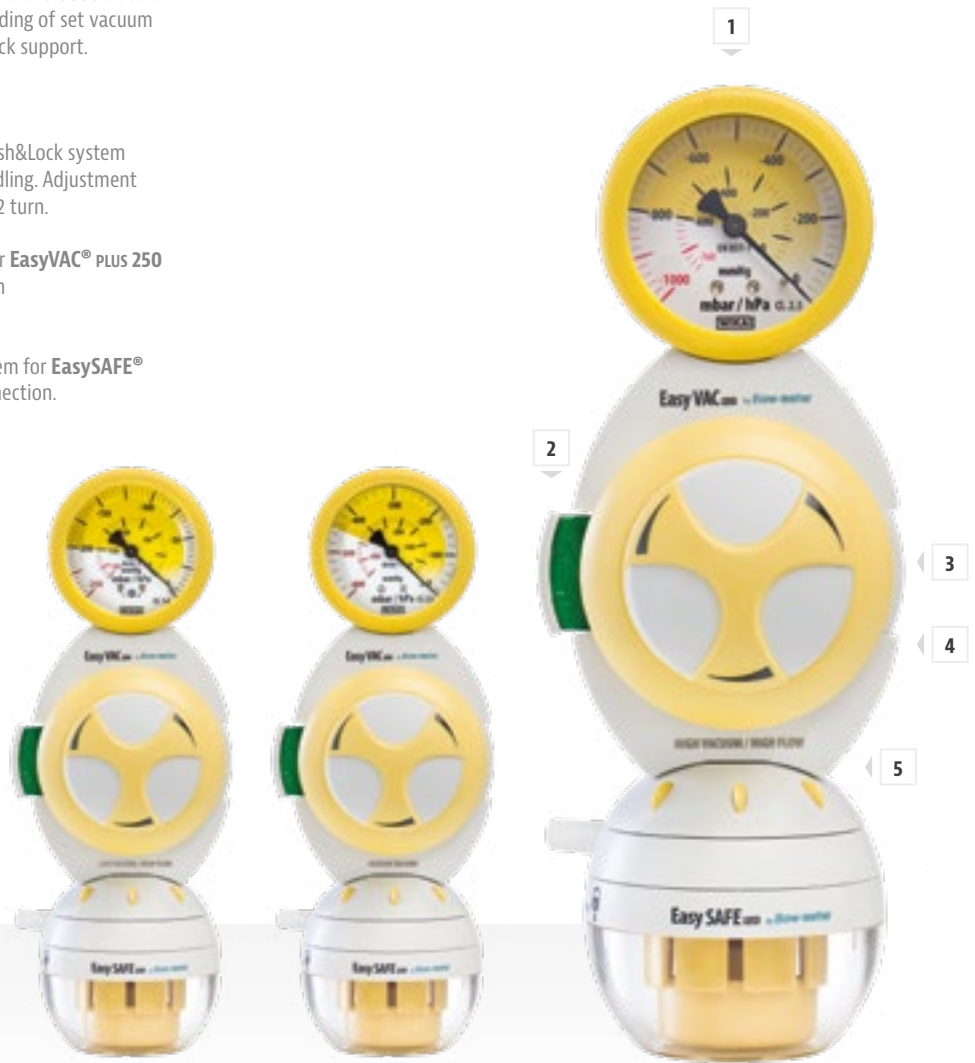

EasyVAC® PLUS 250

EasyVAC® PLUS 600

EasyVAC® PLUS 1000  
with EasySAFE® PLUS safety jar  
(optional)

EasySAFE® PLUS safety jar p. 90

The use of the **EasySAFE® plus** safety jar is highly recommended to get a complete suction device able to guarantee total protection of the vacuum regulator and plant.

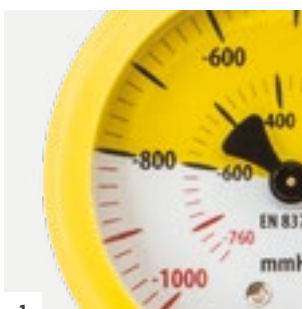

1



2



3



4

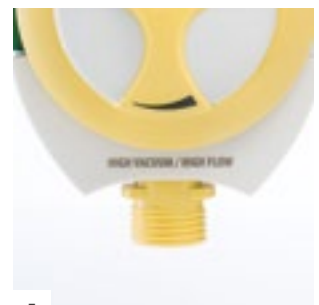

5

# EASYVAC®

## Vacuum regulators

The EASYVAC® continuous suction vacuum regulator is particularly suitable for all medical suction applications in hospitals and nursing homes.

### STRUCTURE

The device is made of a strong techno-polymer body, with a quick I/O switch-button, a suction adjustment knob and a control vacuum gauge with three possible end-of-scale choices: -250 mbar, -600 mbar and -1000 mbar. A protective silicone cover prevents gauge damages caused by possible shocks received during transport or use.

The EASYVAC® vacuum regulators are also designed, through a threaded connection, for connecting directly or indirectly to the normal collection containers for suctioned fluids or for direct connection to the EASYSAFE® safety jar, through a specific quick release integrated connection.

The extreme rationality and simplicity, combined with the sophisticated technical execution, allow both operators and patients to appreciate the safety and reliability of this medical device.

### Main information



EASYVAC® has a vacuum control gauge with double scale and it is available in three possible end of scale choices.

### Related products



Safety jars  
from p. 89



Collection jars  
from p. 96



Probes  
and Accessories  
from p. 103

	EASYVAC® 250	EASYVAC® 600	EASYVAC® 1000
<b>SIZES (LxWxH)</b>	103x92x170 mm		
<b>WEIGHT</b>	0.42 Kg	0.37 Kg	0.37 Kg
<b>MAXIMUM SUCTION RATE</b>	50 L/min. ±5 L/min. at -220 mbar	72 L/min. ±5 L/min. at -550 mbar	105 L/min. ±5 L/min. at -950 mbar
<b>MAXIMUM ADJUSTABLE DEPRESSION</b>	-220 mbar ±20 mbar	-550 mbar ±20 mbar	-950 mbar
<b>VALVE PROTECTING AGAINST EXCESSIVE NEGATIVE PRESSURES</b>	preset with anti-clogging system	preset with anti-clogging system	N/A
<b>MAXIMUM SUPPLY DEPRESSION</b>	-950 mbar		
<b>SUCTION ADJUSTING SYSTEM</b>	with membrane		
<b>STANDARD VACUUM SUPPLY CONNECTION</b>	ISO G. 1/4" M.		
<b>OUTLET CONNECTION</b>	ISO G. 1/2" M. + quick release system for EASYSAFE® or EasySAFE® PLUS safety jar connection		
<b>I/O SWITCH</b>	quick push button type		

- 1 **Vacuum gauge** with colored sectors and double scale (mbar/hPa or mmHg), for easy reading of set vacuum values. Silicone cover and anti shock support.
- 2 **Quick I/O** push switch-button.
- 3 De-pressure excess safety valve (for **EASYVAC® 250** and **EASYVAC® 600** only) with anti-clogging system.
- 4 Vacuum outlet G. 1/2" threaded connection integrated with quick-release connection for **EasySAFE® plus** or **EASYSAFE®** safety jar.

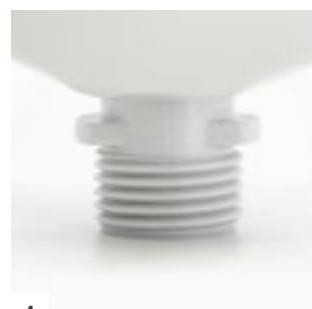
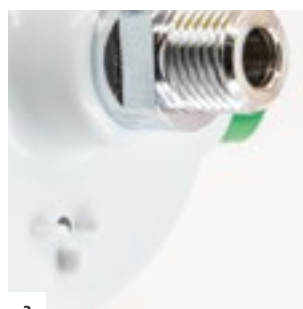
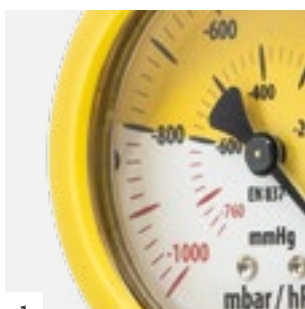





**EasyVAC® PLUS DGT** digital vacuum regulator with **EasySAFE® PLUS** safety jar

P. 70, 90



# VENTURI SUCTION UNITS AND WATER MANOMETERS

flow-meter™

Comparison - Main information

	p. 80 	p. 82 	p. 84 
	EasyAIR®	AV	VA - VD
TYPE	Venturi suction unit	Venturi suction unit	water manometer
GAUGE AND SCALE	standard control vacuum gauge with double scale	standard control vacuum gauge with double scale	tube with graduated scale VD has also a secondary tube for fine adjustment of values
KNOB	big size adjusting knob with soft grip inserts and Push&Lock system	adjusting knob	adjusting knob
PLUS	quick I/O push switch button	quick I/O push switch button only on AV 1000	
			

OXYGEN THERAPY  
 SUCTION OF FLUIDS  
 PRESSURE REGULATORS AND FLOWMETERS  
 ALL MEDICAL GASES  
 FLOWMETER UNITS  
 TERMINAL UNITS  
 ACCESSORIES

# EasyAIR®

“Venturi system” suction units



Excellence in **INNOVATION**  
Breakthrough **TECHNOLOGY**  
Intelligent **DESIGN**

The EasyAIR® Venturi vacuum generating system units are particularly suitable in all hospital applications in which it is necessary to get values of vacuum up to -800 mbar and where a central facility of vacuum generation for suction is missing, often for technical choice.

## STRUCTURE

Such devices are made essentially of an aluminum body housed inside a techno-polymer shock proof shell to protect the unit. Inside, over the “Venturi effect” generating assembly, the needle valve for vacuum adjustment is driven by a large ergonomic control knob having a Push&Lock system, to keep locked the preset vacuum value, and Soft Grip inserts for easy handling and adjusting. The vacuum gauge is available in two end of scale options depending on model (-250 mbar or -1000 mbar) and it is housed in the structure to prevent damages caused by possible shocks received during transport or use. The EasyAIR® Venturi vacuum generating system units are manufactured with outlet threaded connection for screwing in the usual collection containers for suctioned fluids, or for direct connection to the EasySAFE® PLUS safety jar, through a specific quick release integrated connection. The I/O switch button allows the operator to quickly stop and reactivate the suction, keeping unchanged the previous vacuum preset value. The extreme rationality and simplicity, combined with the sophisticated technical execution, allow both operators and patients to appreciate the safety and reliability of this medical device.

## Main information

### Air

As it is well known, the physical principle called “Venturi” allows to get depression from a fluid under pressure. This is obtained, in case of these devices, using medical compressed air coming from the centralized distribution plant.



Being the system working with a principle where medical air under pressure goes released to the environment, the equipment has a high efficiency silencer reducing the noise to allow an adequate level of comfort for patients and operators. The system fits a special device expressly designed and realized with an one-way membrane safety valve, to protect the patient against accidental back pressures.

## Related products



Safety jars  
from p. 89



Collection jars  
from p. 96



Probes  
and Accessories  
from p. 103

	EasyAIR® 250	EasyAIR® 1000
<b>SIZES (LxWxH)</b>	89x123x141 mm	89x123x141 mm
<b>WEIGHT</b>	0.54 Kg	0.57 Kg
<b>MAXIMUM SUCTION FLOW</b>	28 L/min. ±2 L/min. at -220 mbar	40 L/min. +5 L/min. at -800 mbar
<b>VACUUM GAUGE</b>	0 ÷ -250 mbar	0 ÷ -1000 mbar
<b>MAXIMUM ADJUSTABLE DEPRESSION (WITH PLATE PRESSURE ±10%)</b>	-220 mbar ±15 mbar	-800 mbar -25 mbar
<b>SAFETY VALVE AGAINST BACK PRESSURE EXCESS</b>	preset with anti clogging system	N/A
<b>AIR CONSUMPTION AT THE MAXIMUM SUCTION VALUE</b>	25 L/min. ±2 L/min.	60 L/min. ±2 L/min.
<b>NOISE LEVEL</b>	<60 dB	<70 dB
<b>GAS AND SUPPLIED PRESSURE</b>	compressed air 400 kPa (4.0 bar) ±10%	
<b>STANDARD INLET CONNECTIONS</b>	ISO G. 1/4" M. · 1/4" NPT M.	
<b>STANDARD OUTLET CONNECTION</b>	ISO G. 1/2" M. + quick release system for EasySAFE® or EasySAFE® PLUS safety jar connection	

- 1 **Vacuum gauge** with colored sectors and double scale (mbar/hPa or mmHg), for easy reading of set vacuum values.
- 2 **Vacuum adjusting knob** with Push&Lock system and Soft Grip inserts for easy handling.
- 3 **I/O push** switch button.
- 4 Quick release system for **EasySAFE® plus** or **EASYSAFE®** safety jar connection.



▶ WATCH THE VIDEO



EasyAIR® 250

EasyAIR® 1000  
with EasySAFE® plus safety jar  
(optional)

EasySAFE® plus safety jar p. 90

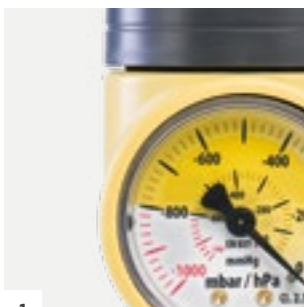

1

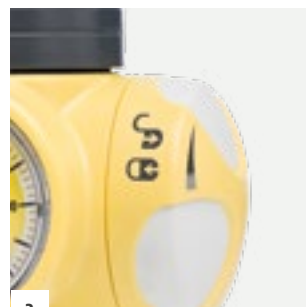

2



3

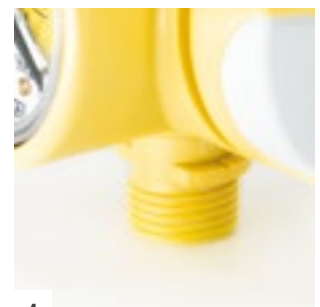

4

# AV

## Venturi suction units

The Venturi AV/500 and AV/1000 vacuum generating system units are particularly suitable in all hospital applications in which it is necessary to get values of vacuum up to -850 mbar and where a central facility of vacuum generation for suction is missing, often for technical choice.

### STRUCTURE

As it is well known, the physical principle called "Venturi" allows to get depression from a fluid under pressure, which is obtained, in case of these devices, using medical compressed air coming from the centralized distribution plant. Such devices are composed essentially of a brass chrome-plated body, a needle valve with vacuum adjustment knob and a vacuum gauge. The version AV/1000 fits also a quick I/O button switch and a large gauge, while in the version AV/500 a protective silicone cover on vacuum gauge avoids damages caused by possible impacts during transport or use.

The AV/500 and AV/1000 Venturi vacuum generating system units are manufactured with outlet threaded connection for screwing in the usual collection containers for suctioned fluids, or for direct connection to the EasySAFE® PLUS safety jar, through a specific quick release integrated connection.

### Main information



Being the system working with a principle where medical air under pressure goes released to the environment, the equipment has a high efficiency silencer reducing the noise to allow an adequate level of comfort for patients and operators. The system fits a special device expressly designed and realized with an one-way safety valve, to protect the patient against accidental back pressures.

### Related products



Safety jars  
from p. 89



Collection jars  
from p. 96



Probes  
and Accessories  
from p. 103

	AV/500	AV/1000
<b>SIZES (LxWxH)</b>	92x72x100 mm	104x72x132 mm
<b>WEIGHT</b>	0.50 Kg	0.83 Kg
<b>MAX. SUCTION RANGE</b>	40 L/min +5%	40 L/min +5%
<b>VACUUM GAUGE SCALE</b>	0 ÷ -1000 mbar	0 ÷ -1000 mbar
<b>MAXIMUM ADJUSTABLE DEPRESSION (WITH PLATE PRESSURE ±10%)</b>	-800 mbar/hPa -25 mbar/hPa	-850 mbar/hPa -25 mbar/hPa
<b>GAS AND SUPPLY PRESSURE (STANDARD VERSION)</b>	compressed air 400 kPa (4.0 bar) ±10%	
<b>ADJUSTMENT OF SUCTION LEVEL</b>	needle valve	
<b>AIR CONSUMPTION AT THE MAX. SUCTION VALUE</b>	60 L/min. ±2 L/min.	
<b>NOISE LEVEL</b>	<70 dB	
<b>INLET CONNECTION</b>	ISO G. 1/4" M.	
<b>OUTLET CONNECTION</b>	ISO G. 1/2" M. + quick release system for EASYSAFE® or EasySAFE® PLUS safety jar connection	

- 1 **Vacuum gauge** with colored sectors scale, for easy reading of set vacuum values.
- 2 The **adjusting knob** allows the suction value setting in a stable and accurate way.
- 3 A quick **I/O button** switch is available on **AV/1000** Venturi unit for immediate suction activation or deactivation.
- 4 On **AV/1000** unit a high performance silencer reduces the noise giving comfort to the patient and health operators during the use.
- 5 Quick release system for **EasySAFE® PLUS** or **EASYSAFE®** safety jar connection.
- 6 **AV/500** and **AV/1000** with direct connection to **EasySAFE® PLUS** p. 90



AV/500

AV/1000

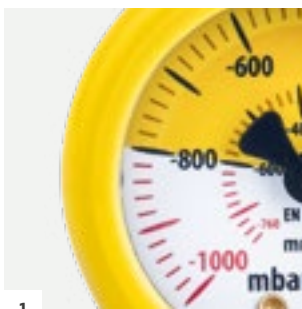

1



2



3

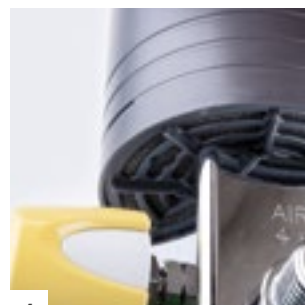

4

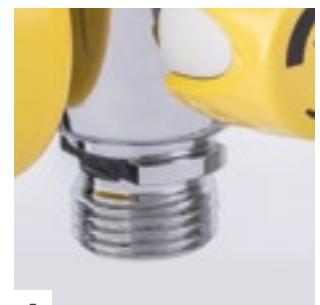

5

# VA - VD

## Water manometers

The water manometers VA and VD series are used for accurate adjustment of vacuum values in the suction in interventions of gastric and chest drainage.

### STRUCTURE

The devices are made essentially of an anodized aluminium head manufactured in anodized aluminum in which a needle valve acts for suction rate adjustments, and where a primary polycarbonate tube containing the water gets the function of measurement and calibration. Inside the tube, a graduated dipstick having scale up to 40 cm (VA/600 and VD/600) or up to 70 cm (VA/1000 and VD/1000) is used to adjust the hydraulic head necessary for the treatment.

### Main information



The VD series has also a secondary tube for fine adjustment of hydraulic head values, and, consequently, of the suction value, up to a maximum value of 5 cm.

### Related products



Vacuum regulators  
from p. 70



Venturi suction units  
from p. 79



Collection jars  
p. 96

	VA/600	VA/1000	VD/600	VD/1000
<b>SIZES (LxWxH)</b>	75x100x710 mm	75x100x1100 mm	80x126x710 mm	80x126x1100 mm
<b>WEIGHT</b>	0.58 Kg	0.75 Kg	0.91 Kg	1.10 Kg
<b>ADJUSTMENT RANGE</b>	0 ÷ -40 cm H <sub>2</sub> O	0 ÷ -70 cm H <sub>2</sub> O	0 ÷ -40 cm H <sub>2</sub> O	0 ÷ -70 cm H <sub>2</sub> O
<b>INLET MAX. DEPRESSION</b>	-950 mbar			
<b>INLET CONNECTION</b>	ISO G. 1/4" M.		hose connector Ø 8.5 mm	
<b>OUTLET CONNECTION</b>	hose connector Ø 8.5 mm			

- 1 Anodized aluminum upper body, with vacuum adjusting knob.
- 2 Graduated scale, detail.

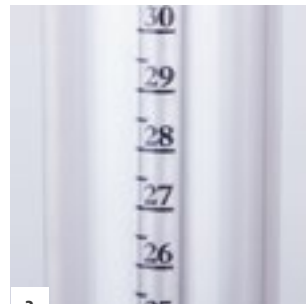



EasyAIR® "Venturi system" suction unit  
with EasySAFE® PLUS  
safety jar













P. 80, 90





# COLLECTION AND SAFETY JARS

## Comparison - Main information

	p. 90 	p. 92	p. 94	p. 96	p. 96	p. 96
						
	<b>EasySAFE® PLUS</b>	<b>EASYSAFE®</b>	<b>MAK/300&amp;500</b>	<b>MAK/1000</b>	<b>MAK/2000</b>	<b>MAK/4000</b>
<b>MATERIAL</b>	polysulfone	polysulfone	polycarbonate	polycarbonate or polysulfone	polycarbonate or polysulfone	polycarbonate or polysulfone
<b>CAPACITY</b>	50 ml	50 ml	MAK/300 300 ml MAK/500 500 ml	1000 ml	2000 ml	4000 ml
<b>OPTION</b>	-	-	Antibacteria version	-	-	-
<b>LID</b>	presence of soft grip inserts to help the handling and quick 1/12 turn to speed up the opening	screw lid	screw lid for Antibacteria version: lid with housing for filter	screw lid	screw or pressure lid	pressure lid
<b>INLET CONNECTION</b>	quick release snap ring 1/2" F.	quick release snap ring 1/2" F.	polycarbonate nut 1/2" F. for vacuum regulator connection	hose connector diam 8.0-9.2 mm or ISO G. 1/2" F.	hose connector diam 8.0-9.2 mm or ISO G. 1/2" F. (for MAK/2000 screw lid only)	hose connector diam 8.0-9.2 mm
<b>OUTLET CONNECTION</b>	hose connector diam 8.0-9.2 mm with 360° rolling position	hose connector diam 8.0-9.2 mm	hose connector diam 8.0-9.2 mm	hose connector diam 8.0-9.2 mm	hose connector diam 8.0-9.2 mm	hose connector diam 8.0-9.2 mm
						

# EasySAFE<sup>®</sup> PLUS

## Safety jar

The new EasySAFE<sup>®</sup> PLUS safety jar is a medical device designed and manufactured for applications of "high flow and high vacuum" joint in use with the EasyVAC<sup>®</sup> PLUS vacuum regulators and with EasyAIR<sup>®</sup> "Venturi system" suction units.

### STRUCTURE

This special safety jar is used to protect the equipment and the plant upstream, should the overflow valve in the main container not be working properly. The EasySAFE<sup>®</sup> PLUS safety jar is made of Polysulfone and fully autoclavable (134 °C - 18 min.), having an overflow floating valve and a housing designed to fit an antibacterial filter to guarantee the complete suction system protection against any contamination. The inlet connection with a quick release snap ring, the rolling 360° position of the patient outlet hose connector and the quick locking system jar-to-lid by 1/12 turn only make simple and easy the connection and removing of the EasySAFE<sup>®</sup> PLUS safety jar to the EasyVAC<sup>®</sup> PLUS vacuum regulators and EasyAIR<sup>®</sup> "Venturi system" suction units. Everything is made to make simple, fast, safe and easy the use by the hospital staff.

### CAPACITY

The collecting jar of this safety device has a deliberately reduced capacity (approx. 50 ml) so that even a small presence of fluid could immediately activate the floating valve to stop the suction.



Excellence in **INNOVATION**  
Breakthrough **TECHNOLOGY**  
Intelligent **DESIGN**

## Main information



The EasySAFE<sup>®</sup> PLUS safety jar is made of polysulfone and fully autoclavable (134 °C - 18 min.).



It's equipped with an overflow floating valve and a housing designed to fit an antibacterial filter to guarantee the complete suction system protection against any contamination.

## Related products



**Vacuum regulators**  
from p. 69



**Venturi suction units**  
from p. 79



**Collection jars**  
p. 96

<b>SIZES (LxWxH)</b>	93x76x74 mm
<b>WEIGHT</b>	0.12 Kg
<b>OVERFLOW SYSTEM</b>	floating valve
<b>PATIENT CONNECTION</b>	hose connector Ø 8.0÷9.2 mm
<b>MAXIMUM APPLICABLE VACUUM VALUE</b>	-950 mbar / 5 min.
<b>CAPACITY APPROXIMATELY</b>	50 ml

- 1 Quick release snap ring for **EasyVAC® plus** and **EasyAIR®** suction devices connection. Presence of Soft Grip inserts to help the handling.
- 2 **Quick 1/12 turn** to speed up the jar cleaning and the antibacterial filter replacement (if filter present).
- 3 **360° rolling positioning**  
hose connector  $\varnothing = 8.0\div 9.2$  mm.
- 4 **Housing** for placing an antibacterial filter (optional).
- 5 **EasyVAC® plus** and **EasyAIR®** fitted with **EasySAFE® plus** (optional).

EasyVAC® plus vacuum regulator, p. 72  
 EasyAIR® "Venturi system" suction unit, p. 80



▶ WATCH THE VIDEO



1

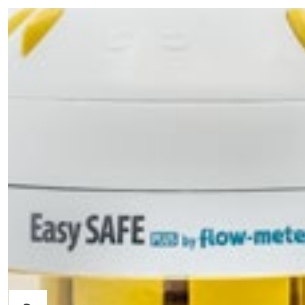

2

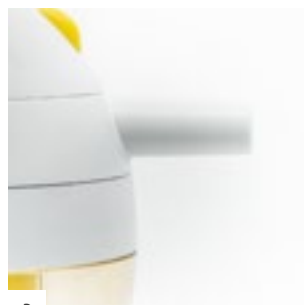

3



4

# EASYSAFE®

## Safety jar

The **EASYSAFE®** safety jar is a medical device designed and manufactured for applications of "high flow and high vacuum".

### STRUCTURE

Designed for use with the **EASYVAC®** vacuum regulators, **EASYSAFE®** is used to protect the equipment and plant upstream, should the overflow valve in the main container not be working properly. Made of a strong and reliable techno-polymer (polysulfone), the **EASYSAFE®** safety jar is autoclavable (134 °C - 18 min.), has an overflow floating valve and a housing designed to fit an antibacterial filter to guarantee the complete suction system protection against contamination.

### CAPACITY

This safety jar has a deliberately reduced capacity (approx. 50 ml) so that even a small presence of fluid can immediately activate the floating valve to stop the suction.

## Main information



The vacuum hose connector and the quick release connection nut make the **EASYSAFE®** simple and easy to set up and to remove from the **EASYVAC®** vacuum regulator.



The **EASYSAFE®** safety jar is made of polysulfone and fully autoclavable (134 °C - 18 min.).

## Related products



**Vacuum regulators**  
from p. 69



**Venturi suction units**  
from p. 79



**Collection jars**  
p. 96

<b>SIZES (LxWxH)</b>	70x90x75 mm
<b>WEIGHT</b>	0.08 Kg
<b>OVERFLOW SYSTEM</b>	floating valve
<b>PATIENT CONNECTION</b>	hose connector Ø 8.0÷9.2 mm
<b>MAXIMUM APPLICABLE VACUUM VALUE</b>	-950 mbar / 5 min.
<b>CAPACITY APPROXIMATELY</b>	50 ml

- 1 **Quick release** lock-unlock nut system.
- 2 **Housing for antibacterial filter**  
Ø 50 mm (optional).
- 3 **EASYVAC® -1000 mbar** fitted  
with **EASYSAFE®** (optional).

EASYVAC® vacuum regulator, p. 74



# Collection containers for small quantity of fluids

The collection containers for suctioned liquids named **MAK/300** and **MAK/500**, are used for the collection of small volumes of suctioned fluids and have been designed and manufactured for applications of "high flow and high vacuum".

## STRUCTURE

The two models have capacities of 300 ml and 500 ml respectively in standard execution, or fitting a special lid for housing an antibacterial filter (Antibacteria version). These devices are generally employed or simply for the collection of suctioned fluids, or like a safety container to protect the equipment and the plant upstream of the suction source, in case the safety overflow valve of the collecting primary container does not work regularly. The jar and the lid are made in polycarbonate, with fittings in brass, with ergonomic screw nut in high-strength polycarbonate. All parts can be sterilized in an autoclave (121 °C - 15 min.).

## Main information



Matched with **EASYVAC®** and **EasyVAC® plus** vacuum regulators, or with **AV** and **EasyAIR®** Venturi suction units, the collection containers **MAK** series provide simplicity of use and versatility, allowing extreme operating economy.

## Related products



**Vacuum regulators**  
from p. 69



**Venturi suction units**  
from p. 79



**Collection jars**  
p. 96

	<b>MAK/300</b>	<b>MAK/300 Antibacteria</b>	<b>MAK/500</b>	<b>MAK/500 Antibacteria</b>
<b>INNER VOLUME</b>	300 ml	300 ml	500 ml	500 ml
<b>SIZES (LxWxH)</b>	70x84x180 mm	70x84x206 mm	70x84x212 mm	70x84x237 mm
<b>WEIGHT</b>	0.20 Kg	0.24 Kg	0.21 Kg	0.25 Kg
<b>SUPPLY DEPRESSION</b>	max -950 mbar - 5 min.			
<b>OVERFLOW VALVE</b>	floating valve			
<b>INLET CONNECTION</b>	ISO G 1/2" F.			
<b>OUTLET CONNECTION</b>	hose connector Ø 8.0 ÷ 9.2 mm			

1 **Housing for antibacterial filter** Ø 50 mm  
(for Antibacteria version only).

2 **Polycarbonate nut**  
for vacuum regulator  
connection.



MAK/300

MAK/500

MAK/300  
Antibacteria

MAK/500  
Antibacteria



1



2

# Large capacity collection jars

The MAK series large size containers for suctioned liquids are designed and manufactured for “high flow and high vacuum” applications. They have a long history, full of positive praises for their versatility, safety and economy.

## STRUCTURE

Jar and lid are made of polycarbonate, and two straight inlet/outlet connectors are integrated into the cover (except in the above mentioned version having direct connection to the vacuum regulator that fits one chrome-plated brass nipple with polycarbonate connecting nut). All containers are equipped with an overflow valve, are supplied with two spare elbow connectors, to set up any possible connection between the jar, the suction line and the patient, and are obviously autoclavable (121 °C - 15 min.). If higher sterilization temperatures are required, a PSU version is also available for the three sizes (134 °C - 18 min.). An external graduated scale gives indications about the level of filling. In conjunction with the various supports and accessories available on request, the **MAK** collection jars grant simplicity in use, versatility and an important operating economy.

## Main information



They are available with a capacity of 1000 ml with screw cap, of 2000 ml with screw and pressure lid and 4000 ml with pressure lid. Versions having capacities 1000 ml and 2000 ml can also be supplied, as an option, with a special lid with direct thread connection to the vacuum regulator.

## Related products



Vacuum regulators  
from p. 69



Venturi suction units  
and Water manometers  
from p. 79

	MAK/1000	MAK/2000 with screw lid	MAK/2000 with pressure lid	MAK/4000
<b>INNER VOLUME</b>	1000 ml	2000 ml	2000 ml	4000 ml
<b>SIZES (LxWxH)</b>	110x110x235 mm	135x135x285 mm	125x125x285 mm	175x175x310 mm
<b>WEIGHT</b>	0.38 Kg	0.49 Kg	0.49 Kg	0.99 Kg
<b>SUPPLY DEPRESSION</b>	max -950 mbar - 5 min			
<b>OVERFLOW VALVE</b>	floating valve			
<b>INLET CONNECTION</b>	hose connector Ø 8.0÷9.2 mm or ISO G 1/2" F. (for MAK/1000 and MAK/2000 screw lid only)			
<b>OUTLET CONNECTION</b>	hose connector Ø 8.0÷9.2 mm			

- 1 **Screw lid** (for MAK/1000 and MAK/2000 only) showing the overflow valve and the removable elbow connectors.
- 2 **Pressure lid** (MAK/2000 and MAK/4000) with overflow valve and removable elbow connectors.
- 3 **Lid version for vacuum regulator** direct fitting and elbow connector.
- 4 **MAK large capacity collection jars** are also available in PSU version.



MAK/1000

MAK/2000

MAK/4000



1



2



3



4

# FLOVAC®

## DISPOSABLE CONTAINERS SYSTEM FOR THE COLLECTION OF SUCTIONED FLUIDS

designed and manufactured for “high flow and high vacuum” applications in medical suction field to collect the organic fluids.

This system is the best expression of safety, practicality and simplicity of use, both for the operators and for hospital plants and environment, thanks to the use of absolutely reliable manufacturing materials. The hermetic lid sealing makes the disposal procedure particularly hygienic, simple and safe for the patient and for the staff charged to remove and handle the device.



### WHY HYDROPHOBIC FILTER AND HOW DOES IT WORK?

The **FLOVAC® HYDROPHOBIC** filter is made of 3 layers having antibacterial, smoke filtration and hydrophobic functions. The filter stops the suction when wet because the fluid reaches the maximum collection level.

### GELLING KIT

The gelling kit gives further safety to an highly efficient system. It is a **special absorbing powder transforming liquids in a semi-solid mass**. This grants higher safety for operators charged to clean, handle and transport potentially infected materials.

### FLOVAC® LINER

The **FLOVAC® LINER** consists of a soft bag hermetically welded to a rigid lid. **LINERS** are available in 4 capacities and they work when inserted in the related PC reusable and autoclavable rigid containers.

### FLOVAC® CANISTER

The **FLOVAC® CANISTER** is a complete disposable system. It consists of a single-use rigid canister coupled with a lid hermetically fixed on it thanks to spring clips preventing any accidental opening.



For any additional information, refer to the specific product catalogues.

from  
**powder**



*to gel*

practicality **safety** *simplicity*

The gelling kit allows to absorb and incorporate all liquids present in the **FLOVAC**<sup>®</sup> container and to prevent, in such a way, dangerous contamination risks for the hospital staff in case of biological fluids accidental leakage.

# FLOVAC®

## Disposable containers

The FLOVAC® disposable containers are used for the collection of organic fluids in suction and have been designed and manufactured for applications of “high flow and high vacuum” (EN ISO 10079-1 and EN ISO 10079-3).

This system mixes simplicity and practicality, guaranteeing great safety from contamination for operators, for the suction plants and for the environment, thanks to the use of the latest manufacturing technologies and of absolutely reliable materials.

### THE HYDROPHOBIC FILTER

The FLOVAC® system is the result of twenty years of **flow-meter™** experience in the production of disposable devices for the collection of suctioned fluids and get the most important characteristics in its special hydrophobic filter. This filter protects the vacuum generating devices or the centralized suction plant from contamination, as it performs the function of overflow valve, turning off the suction when wetted by the fluid reaching the maximum level of container filling.

### THE MECHANICAL VALVE

To complete the FLOVAC® range **flow-meter™** has designed the configuration with mechanical overflow valve and antibacterial filter, available both for **LINER** and for **CANISTER** versions.

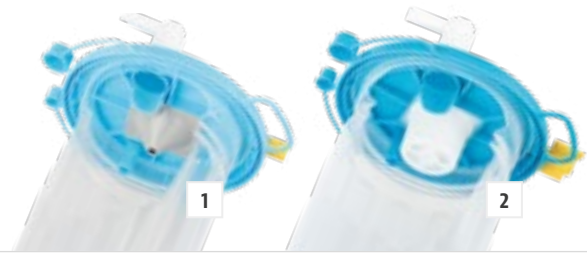

## Main information

The containers are made in four sizes, to be used according to the effective requirements about the volumes expected to be suctioned, and they are manufactured in two distinct versions:

### LINER VERSION

**Soft bag material:** LDPE (low density polyethylene), individually packed in blisters.

**Available capacities:** 1.0 L - 1.5 L - 2.0 L - 3.0 L

### CANISTER VERSION

**Jar material:** High Clarity Polypropylene connection between jar and lid through pressure seal with permanent fastening spring clips.

**Available capacities:** 0.5 L - 1.0 L - 2.0 L - 3.0 L

Both versions show differentiated connecting ports for connecting the collection container with the suction line, with the patient and, if necessary, with another container to increase the suctioned fluid capacity (**TANDEM** port).



<b>LID MATERIAL</b>	HDPE (High Density Polyethylene)
<b>OVERFLOW VALVE</b>	Hydrophobic filter with antibacterial, antiviral and NO-SMOKE® protection or mechanical overflow valve with antibacterial filter
<b>VACUUM PORT</b>	conic connector, female
<b>PATIENT PORT</b>	Ø 14.0 ÷ 15.5 mm (Ø 8.0 ÷ 9.2 mm with elbow connector)
<b>TANDEM PORT</b>	Ø 8.0 ÷ 9.2 mm
<b>MAXIMUM SUCTION DEPRESSION</b>	-950 mbar/5 min.
<b>MAXIMUM GRADUATION INTERVAL</b>	50 ml
<b>PATIENT HOSE SIZES</b>	inner Ø ≥ 6 mm - L max = 2.5 m
<b>VACUUM HOSE SIZES</b>	inner Ø ≥ 6 mm - L max = 1.8 m
<b>HYDROPHOBIC FILTER WITH ANTIBACTERIAL, ANTIVIRAL AND NO-SMOKE® PROTECTION - MAIN CHARACTERISTICS</b>	
<b>BACTERIAL AND VIRAL FILTRATION EFFICIENCY</b>	>99.99995%
<b>MEMBRANE</b>	100% expanded PTFE
<b>PREFILTER</b>	micro fiberglass HEPA Air Filter

For any additional information, refer to the specific product catalogues.

- 1 **Hydrophobic** filter.
- 2 **Mechanical** valve.

### THE LID

The lid keeps space for all the connection ports, easily identifiable and not exchangeable each other: the **VACUUM** port, connected to the suction, the **PATIENT** port having a removable elbow connector to get larger port diameter and allowing suction of fluids containing also small parts of organic material, and the **TANDEM** port, for the connection in cascade of two or more identical devices to increase the collection capacity. Two plugs placed on the lid allow the hermetic seal of the **PATIENT** and **TANDEM** ports, while, always integrated in the cover, a handle facilitates the **LINER** removal from the support jar, as well as simplifies the transport of the container. The lid hermetic seal makes the use and disposal particularly hygienic, simple and safe, both for the patient and for the staff involved with the removal and replacement of the **LINERS** and **CANISTERS**. **LINER** system is equipped with anti-reflux system to prevent patient and operator to come in touch with contaminated fluids in case of spillage through the ports happening during the hose disconnection. The **FLOVAC®** system includes a wide and complete range of accessories.



The **FLOVAC® HYDROPHOBIC** filter is made of 3 layers having antibacterial, smoke filtration and hydrophobic functions.



Microfiberglass pre-filter



100% expanded PTFE membrane  
Hydrophobic and antibacterial



- 1  Pre-filled **LINER FLOVAC®** with gelling powder bag (on request)
- 2  Gelling powder bag to be inserted by operator for **CANISTER FLOVAC®** only (on request)
- 3  Bottles 500 g with funnel/doser to be poured into **LINERS** and **CANISTERS** after use and before disposal



# CONNECTIONS AND ACCESSORIES

## FOR SUCTION DEVICES

All **flow-meter™** devices used in suction applications, like vacuum regulators, Venturi suction units and water manometers, can be coupled to the terminal units through the special connections designed and made according to the various national and international standards. These connections to the vacuum or medical air (for Venturi units) distribution systems, on which the user operates frequent connections and detachments, must ensure high safety when used by the health professionals. The following pages contain main information regarding the available range of probes with thread connection, for direct coupling on outlets, and hose connection, for mounting on wall rails or floor stands. Here we present also various types of support systems for all our kinds of collection jars and our catheter containers too.

VACUUM PROBES WITH THREAD AND HOSE CONNECTION, VACUUM REGULATOR OUTLET HOSE CONNECTION, RAIL CLAMPING SYSTEMS, WALL BRACKETS, STAINLESS STEEL RAIL, CATHETER CONTAINERS, SUPPORTING DEVICES

# Probes with thread connection



**AFNOR NF-S 90-116** probe, thread ISO G. 1/4" F.



**AFNOR NF-S 90-116 type EASYFIX®** probe, thread ISO G. 1/4" F.



**UNI 9507** probe, thread ISO G. 1/4" F.



**BS 5682** probe, thread ISO G. 1/4" F.



**DIN 13260** probe, thread ISO G. 1/4" F.



**SS 875 24 30** probe, thread ISO G. 1/4" F.



**JIS T 7101** probe, thread ISO G. 1/8" M.



**SANS 1409** probe, thread ISO G. 1/4" F.



**OHMEDA** probe, thread ISO G. 1/4" F.

# Probes with hose connection

## Vacuum regulator outlet hose connection · Stainless steel rail

### Probes with hose connection



### Vacuum regulator outlet hose connection



### Stainless steel rail

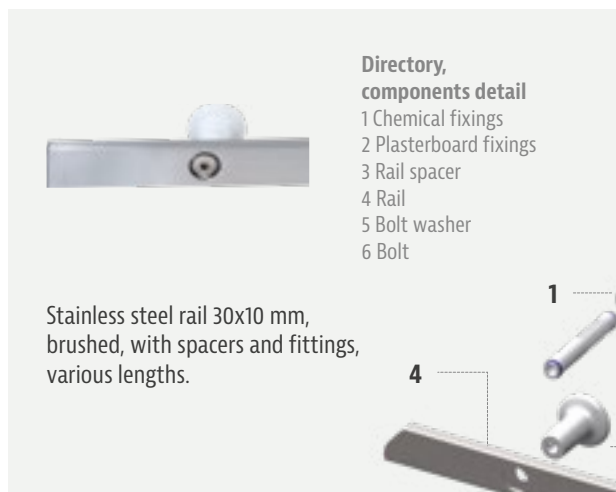

# Rail clamping systems

## Wall brackets · Catheter containers

### Rail clamping systems



ABS clamp bracket for rail 30x10 mm and 50x10 mm, with nipple threaded ISO G. 1/4" F. and hose connector Ø 7.5 mm.



ABS clamp bracket for rail 30x10 mm and 50x10 mm, with slide 25x5 mm, 30x5 mm, 45x5 mm.

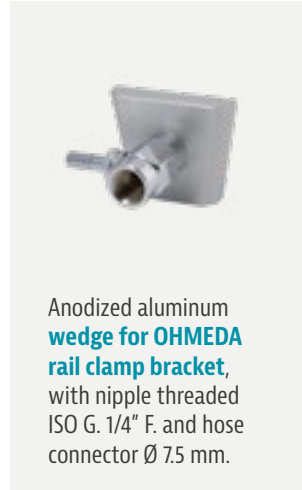

Anodized aluminum wedge for OHMEDA rail clamp bracket, with nipple threaded ISO G. 1/4" F. and hose connector Ø 7.5 mm.

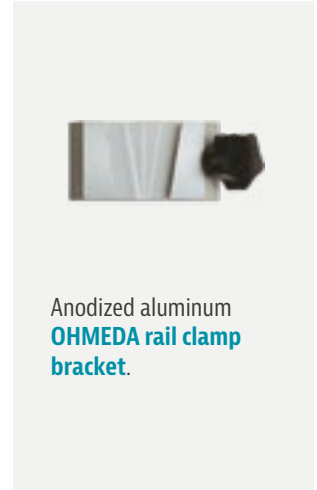

Anodized aluminum OHMEDA rail clamp bracket.

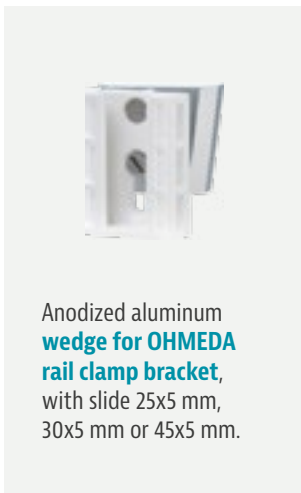

Anodized aluminum wedge for OHMEDA rail clamp bracket, with slide 25x5 mm, 30x5 mm or 45x5 mm.

### Wall brackets



ABS wall bracket: 25x5 mm, 30x5 mm, 45x5 mm slide.

### Catheter containers

**flow-meter™** catheter containers are accessories allowing the operators to put down in a hygienic way the suction hose during their activity. They are made with tube of polycarbonate Ø 54 mm by 400 mm length, and they are fully autoclavable (121 °C - 15 min.).

Moreover these containers can be placed in a specific support ring for rail or trolley, in a single or twin construction.



Single and twin construction

## Supporting devices for collection jars

The range of jars supporting devices includes trolleys, metallic support basket and ABS support rings for all containers sizes and models. Baskets and rings are manufactured with a strong and stiff hook matching with main slide sizes.



ABS support ring for **MAK/1000** jar, slides 25x5, 30x5, 41x4, 45x5 mm hook



ABS support ring for **MAK/2000** jars, slides 25x5, 30x5, 41x4, 45x5 mm hook



ABS support ring for **FLOVAC®** jars, slides 25x5, 30x5, 41x4, 45x5 mm hook



Metallic support basket for **MAK/4000** jar, slide 25x5 mm



Clip fixing 25x5 mm rings for trolleys, brackets and wall plates





5 wheels trolley up to 4 different jars (**MAK** and **FLOVAC**®) with vacuum gauge and 4 ON-OFF taps



5 wheels trolley up to 4 different jars (**MAK** and **FLOVAC**®) with handle



5 wheels trolley up to 4 different jars (**MAK** and **FLOVAC**®) with vacuum regulator and 4 ON-OFF taps



5 wheels trolley up to 4 different jars (**MAK**) and up to 12 jars (**FLOVAC**®) with vacuum regulator and safety jar **EASYSAFE**® and 4 ON-OFF taps

# Suction trolley units

The flow-meter™ suction trolley units allow to perform suction interventions in a rational and effective manner, as they include in one suction system all the necessary devices for a broad range of surgical and medical procedures, providing the operators with the most suitable solution of use in a hospital environment.

This suction unit system allows to connect to the terminal units fitted on the trolley head one or two **EASYVAC®** vacuum regulators, preferably completed with the relative **EASYSAFE®** safety jar. The slide bracket system on the stand allows to accommodate up to 4 supports for the collection containers of suctioned fluids, disposable or not. The trolley head fits also the catheter container support rings, one for each suction circuit. This to allow the operator to safely store the patient tube after use. The trolley unit fits five antistatic rotating castors, two of which with locking pedal, this to get always an easy, safe and rational positioning. Please refer to the individual product data sheets to see the characteristics of the various devices associated with the trolley.

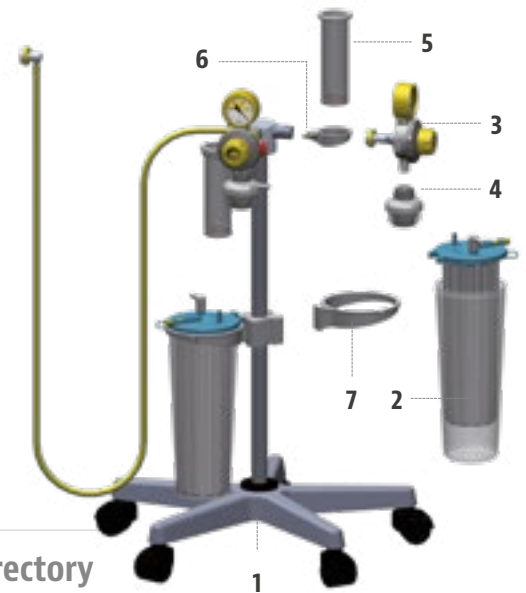

## Directory

- 1 Universal trolley complete with stand, supply hose and probe
- 2 **Collection container**
  - Collection jar **MAK/1000** - **MAK/2000** - **MAK/4000**
  - Canister **FLOVAC®** 0.5 L - 1.0 L - 2.0 L - 3.0 L
  - Liner **FLOVAC®** 1.0 L - 1.5 L - 2.0 L - 3.0 L
  - PC reusable jar for Liner **FLOVAC®** 1.0 L - 1.5 L - 2.0 L - 3.0 L
- 3 **Vacuum regulator**
  - Vacuum regulator **EasyVAC® PLUS** or **EASYVAC®/250** with probe according to the different standards
  - Vacuum regulator **EasyVAC® PLUS** or **EASYVAC®/600** with probe according to the different standards
  - Vacuum regulator **EasyVAC® PLUS** or **EASYVAC®/1000** with probe according to the different standards
- 4 **Safety jar**
  - Safety jar **EasySAFE® PLUS** or **EASYSAFE®** for vacuum regulator **EASYVAC®** or **EasyVAC® PLUS**
- 5 **Catheter container**
  - Catheter container Ø 50 mm - L=200 mm
- 6 **Ring for catheter container**
- 7 **Support ring** for collection container
  - Support ring with slide 25x5 mm
    - for collection canisters **FLOVAC®**
    - for collection jars **MAK/1000**
    - for collection jars **MAK/2000**
  - Support basket with slide 25x5 mm for collection jars **MAK/4000**

<b>DIMENSIONS (LxWxH)</b>	580x580x870 mm
<b>WEIGHT</b>	5.0 Kg (vacuum regulators, collection jars and accessories excluded)
<b>TERMINAL UNITS FOR VACUUM REGULATORS CONNECTION</b>	2 AFNOR NF-S 90-116 / UNI 9507 / DIN 13260 / BS 5682 / SS 875 24 30 outlets
<b>VACUUM SUPPLY HOSE</b>	EN ISO 5359 yellow; length 3 m
<b>PROBE FOR UNIT CONNECTION TO VACUUM PLANT</b>	AFNOR NF-S 90-116 / UNI 9507 / DIN 13260 / BS 5682 / SS 875 24 30
<b>BRACKET SYSTEM FOR COLLECTION JAR SUPPORTS</b>	4 slides with dimensions 25x5 mm

- 1 Probe with hose connector  
(different standards available).
- 2 Outlets (different standards available).
- 3 Support stand with 4 slides.
- 4 Vacuum anti-squeezing hose.
- 5 Anti-static wheels.



Assembly example.



# PRESSURE REGULATORS AND FLOWMETERS

ALL MEDICAL GASES

PRESSURE REGULATORS FOR CYLINDERS AND FLOWMETERS

In this section we propose our pressure regulators (FM series and MU) and our Rs flowmeters for applications other than oxygen therapy. The supply of all medical gases through measurement devices requires accuracy and experience in manufacturing and development, so we underline once more that all these devices are made in full compliance with **European standards** and technical regulations, as well as requirements of Regulation (EU) MDR 2017/745 and the approval criteria set by national and international certified bodies.

**LABORATORIES AND TESTS**

All regulators and flowmeters are rigorously tested, both in **flow-meter™** own quality-assurance laboratories and by independent validated laboratories, to ensure that the products meet all the requirements of the medical applications in any foreseeable therapeutic condition.



hospitals



emergency



home care

The CE marking procedure is carried out according to the requirements of a complete EN ISO 13485 quality system.

# FM

## Pressure regulators

The single-stage FM pressure regulators are designed for direct fitting on medical gas cylinders in the different reference standards.

### STRUCTURE

The single-stage FM pressure regulators are equipped with single gauge to check the remaining contents of the cylinder or with double gauge to check and adjust the working conditions according to the user requirements. They can be supplied with the calibration of the outlet pressure preset or adjustable through a knob.

The body is manufactured of chrome-plated brass, with a pre-calibrated overpressure safety valve to protect against any malfunction of the system. A protective silicone cover prevents gauge damages caused by possible shocks received during transport or use. Cylinder inlet connections are available for all the most commonly used medical gases, according to the various standards used in different Countries.

### SPECIAL VERSION FOR AMBULANCES

A special version, made for ambulances applications, fits a pressure gauge with electric signal 4-20 mA or 0.5-4.5 V output for the continuous monitoring of the supplied pressure and with system control panel interface.

### Main information



The FM pressure regulators are equipped with single or double gauge.



Calibration of the outlet is preset or adjustable through a knob (double gauge version).

### Related products



Cylinder inlet connections  
from p. 57

	FM single gauge		FM double gauge	
	MAX. SIZES (LxWxH)	MAX. WEIGHT	MAX. SIZES (LxWxH)	MAX. WEIGHT
<b>OUTLET</b>				
<b>TUBING CONNECTOR Ø 6 mm</b>	100x136x120 mm	0.95 Kg	102x136x113 mm	1.14 Kg
<b>TERMINAL UNIT</b>	100x137x120 mm	1.21 Kg	102x137x113 mm	1.40 Kg
<b>THREAD ISO G. 1/4" F.</b>	100x105x120 mm	0.92 Kg	102x105x113 mm	1.11 Kg
<b>MAXIMUM INLET PRESSURE</b> 200 bar (100 bar for N <sub>2</sub> O and CO <sub>2</sub> )				
<b>INLET CONNECTIONS</b> UNI 11144 · NF-E 29-650 · BS 341-3 · DIN 477-1				
<b>TERMINAL UNIT TYPE (IF PRESENT)</b> AFNOR NF-S 90-116 · UNI 9507 · BS 5682 · DIN 13260 · SS 875 24 30				
<b>GASES OPTIONS</b> O <sub>2</sub> · AIR · N <sub>2</sub> O · N <sub>2</sub> · CO <sub>2</sub> · Helium · Hydrogen				

- 1 Outlet for FM pressure regulator (optional).
- 2 One of the several inlet connections for cylinder direct fitting.

FM pressure regulator with single gauge for N<sub>2</sub>O



FM pressure regulator with single gauge



FM pressure regulator with double gauge



1



FM pressure regulator with special gauge for ambulances

## Pressure regulator for ambulances

<b>GASES OPTIONS</b>	Oxygen
<b>GAUGE ELECTRICAL FINAL</b>	4-20 mA or 0.5-4.5 V output
<b>OUTLET CONNECTOR</b>	hose connector with gas specific rotating nut

# MU

## Pressure regulators

The MU pressure regulators are designed for direct fitting on standard medical gas cylinders.

### STRUCTURE

The MU pressure regulators are manufactured with body of chrome-plated brass, with a pre-calibrated overpressure safety valve to protect against any malfunction of the system, with an inlet connection for O<sub>2</sub> or Air according to the various standards used in different Countries and with an outlet hose connector.

### VERSIONS

They are available in a version with preset calibration of the outlet pressure with single gauge to check the cylinder contents, or with adjustable pressure and a flow gauge to check the flow of the supplied gas. A protective silicone cover prevents gauge damage caused by possible shocks received during transport or use.

### Main information



The MU pressure regulators are equipped with single or double gauge.



It is also available the version with front or side flow gauge, to allow to check the flow of the supplied gas.

### Related products



Cylinder inlet connections  
from p. 57

	SIZES (LxWxH)	WEIGHT
<b>OUTLET</b>		
<b>HOSE CONNECTOR Ø 6 mm</b>	127x51x121 mm	0.64 Kg
<b>FRONT FLOW GAUGE</b>	135x87x121 mm	0.72 Kg
<b>SIDE FLOW GAUGE</b>	135x101x121 mm	0.71 Kg
<b>MAXIMUM INLET PRESSURE</b> 200 bar		
<b>INLET CONNECTION</b> UNI 11144 · EN 850 · NF-E 29-650 · BS 341-3 · DIN 477-1 · ISO 5145		
<b>FLOW GAUGE END OF SCALE VALUE (IF PRESENT)</b>	9 LPM	
<b>FLOW GAUGE ACCURACY (IF PRESENT)</b>	±10% read value or ±0.5 L/min. if greater	

- 1 **Cylinder gas pressure gauge** with colored section and double scale.
- 2 **Inlet connection** according to international standards.
- 3 **Flow adjusting knob.**



MU  
pressure regulator

1



MU  
pressure regulator  
with front flow gauge

2



3

MU  
pressure regulator  
with side flow gauge



1



2



3

# Rs

## Variable area flowmeters

The flowmeters type **Rs** are instant flow measuring devices suitable for the dosage of all medical gases.

### STRUCTURE

They can be produced in version with pressure compensated or not compensated and manufactured both with single or twin flow tubes in order to allow a double and independent gas supply using a single gas source. The body is manufactured in chrome-plated brass with metal fittings and the measurement group is made of high resistance polycarbonate, making them ideal for the toughest applications.

### SOLUTIONS AND OPTIONS

They are also available in different solutions of pressure calibration, various options of scale, normal or extended (L version) to allow a better reading of the indicated values. Several options are proposed concerning the threaded connections, inlet or outlet, offering an endless variety of combinations to meet all application requirements.

### Main information



**Rs** can be manufactured in single or twin configuration in order to allow double and separate gas supply using a single gas source.



The flowmeters type **Rs** fit a needle valve with a knob in color code for the immediate identification of the supplied gas.

### Related products



Probes and Accessories  
for various gases  
from p. 154

<b>SIZES (LxWxH)</b>	80x33x136 mm
<b>WEIGHT</b>	0.24 Kg
<b>SUPPLY MAX. PRESSURE</b>	600 kPa
<b>END OF SCALE VALUES - 350 KPA</b>	1 L/min. · 4 L/min. · 5 L/min. · 10 L/min. · 15 L/min. · 20 L/min. · 30 L/min. · 50 L/min.
<b>FLUIDS</b>	O <sub>2</sub> · AIR · N <sub>2</sub> · CO <sub>2</sub> · N <sub>2</sub> O
<b>ACCURACY</b>	±10% read value or ±0.5 L/min. if greater (±10% E.O.S. value for flow E.O.S. ≤ than 1 L/min.)
<b>INLET CONNECTION</b>	ISO G 1/8" F. · ISO G 1/4" M. · 1/4" NPT M. · 3/8" ISO 3253 F. · M 12x1 F.
<b>OUTLET CONNECTION</b>	1/4" ISO 3253 M. · 3/8" ISO 3253 M. · M 12x1.25 M. · 1/2" GAS M. 9/16" UNF EN 13544-2 M. · 1/2" BSF F.

- 1 **Rs ABS knobs**, color coded for gas specificity.



**Rs twin**  
chrome-plated brass body  
twin construction

**Rs**  
chrome-plated brass body  
single construction



1



# FLOWMETER UNITS

DEVICES FOR ANESTHESIA  
AND HIGH FLOW DEVICES

FLOWMETER DEVICES, BY-PASS SYSTEMS AND HIGH FLOW DEVICES

The range of **anesthesia flowmeter units** series FM, SF and RM, available in different configurations, makes it possible to offer many options to meet various requirements in the operating theatre, mobile units and field hospitals.

#### SAFETY

**flow-meter™** anesthesia flowmeters are manufactured in total compliance with all relevant EU standards and meet the requirements of the Regulation (EU) MDR 2017/745, ensuring that they can be relied upon for total safety even in the most stressful situations.



hospitals



emergency



home care

# FM

## Flowmeters

The FM flowmeters are devices for the supply of medical gases having from two to six antistatic and graduated tubes and completed with an integrated dosage unit.

### STRUCTURE

The body is made of anodized aluminum and the inlet connections for O<sub>2</sub>, Air and N<sub>2</sub>O at the bottom of the flowmeter are arranged to be connected to hospital centralized gas plants or to cylinders complete with pressure regulators.

### WORKING PRINCIPLE AND SAFETY

The gas feeding unit includes a safety valve automatically blocking the N<sub>2</sub>O supply when the feeding pressure of O<sub>2</sub> drops below the value of approximately 0.4 bar. The mixtures of O<sub>2</sub> and N<sub>2</sub>O can be supplied to the patient through a dosage unit. An incorporated mixing device proportions the N<sub>2</sub>O in such a way that a minimum of at least 30% of O<sub>2</sub> is always present in the gas mixture. At the outlet of the dosage unit, an anesthesia evaporator can be connected or the gas mixture can be supplied directly to the patient through the gas feeding unit. The O<sub>2</sub>+ flush button can be used for a quick supply of O<sub>2</sub> directly at the outlet of the mixture on the gas feeding unit.

### Main information



The FM flowmeter can be supplied from two to six tubes.



The O<sub>2</sub>+ flush button can be used for a quick supply of O<sub>2</sub> directly at the outlet of the mixture on the gas feeding unit.

### Related products



Hoses and probes for various gases from p. 155

	FM 2200	FM 2300	FM 2500	FM 2800	FM 2900
<b>SIZES (LxWxH)</b>	148x143x318 mm	148x143x318 mm	148x143x318 mm	148x143x318 mm	148x190x318 mm
<b>WEIGHT</b>	5.52 Kg	5.57 Kg	5.64 Kg	5.69 Kg	7.20 Kg
<b>DOSAGE RANGE</b>	O <sub>2</sub> 0.2 - 15 L/min. N <sub>2</sub> O 0.2 - 12 L/min.	O <sub>2</sub> 0.1 - 1 L/min. 0.2 - 15 L/min. N <sub>2</sub> O 0.1 - 1 L/min. 0.2 - 12 L/min.	O <sub>2</sub> 0.2 - 15 L/min. Air 0.2 - 15 L/min. N <sub>2</sub> O 0.2 - 12 L/min.	O <sub>2</sub> 0.1 - 1 L/min. 0.2 - 15 L/min. Air 0.2 - 15 L/min. N <sub>2</sub> O 0.1 - 1 L/min. 0.2 - 12 L/min.	O <sub>2</sub> 0.1 - 1 L/min. 0.2 - 15 L/min. Air 0.2 - 15 L/min. N <sub>2</sub> O 0.1 - 1 L/min. 0.2 - 12 L/min. CO <sub>2</sub> 0.1 - 2 L/min. (limited at 1 L/min.)
<b>ACCURACY</b>	±10% read value between 10% (or ±0.3 L/min. if greater) and 100% E.O.S. and ±0.15 L/min for flow < 10% E.O.S (±0.1 L/min for flow E.O.S. ≤ than 2 L/min.)				
<b>INLET PRESSURES</b>	3.5 - 5 bar ±20%				
<b>N<sub>2</sub>O BLOCKING DEVICE</b>	the supply of N <sub>2</sub> O is blocked when the O <sub>2</sub> pressure drops below 0.4 bar ±0.2 bar.				
<b>CHARGE LOSS LEVEL, SIDE UNDER PRESSURE (BEFORE THE ADJUSTING NEEDLE VALVES)</b>	less than 25 ml/min. in normal pressure conditions (ISO 5358)				
<b>CHARGE LOSS LEVEL, LOW PRESSURE SIDE (AFTER THE ADJUSTING NEEDLE VALVES, VAPORIZER EXCLUDED)</b>	less than 25 ml/min. at 30 cm H <sub>2</sub> O				
<b>HYPOXYGUARD SYSTEM</b>	at least 30% -3% O <sub>2</sub> is guaranteed in the mixture with N <sub>2</sub> O opening value equal to 0.4 L/min. (with inlet pressures of 3.5 bar)				
<b>MIXED GASES OUTLET CONNECTION</b>	conical connection 23 mm F ISO DIN 5356/1				
<b>GASES INLET CONNECTIONS</b>	hose connector Ø 6 mm				
<b>O<sub>2</sub> QUICK DOSAGE (IF FORESEEN)</b>	when pushed it can supply more than 45 L/min. O <sub>2</sub>				

- 1 Gas selector.
- 2 O<sub>2</sub>+ flush button.
- 3 Gas adjusting knob.



1

2

3

# SF

## Flowmeters

The SF flowmeters are devices for the supply of medical gases particularly suitable in respiratory therapy.

### STRUCTURE

They are made of anodized aluminum body, and they are available with one or more graduated tubes and a built-in dosage unit. The inlet connections are at the bottom of the unit and arranged to be connected to the hospitals centralized gas plants or to cylinders complete with pressure regulators. For veterinary use, an anesthesia evaporator can be connected at the outlet of the dosage unit.

### Main information



The SF flowmeter can be supplied with 1 or more graduated tubes.

### Related products



Hoses and probes for various gases from p. 155



O<sub>2</sub>+ flush device p. 136

	SF 1	SF 2	SF 3	SF 4
<b>SIZES (LxWxH)</b>	115x73x294 mm	115x114x294 mm	115x137x294 mm	115x170x294 mm
<b>WEIGHT</b>	1.12 Kg	1.61 Kg	2.00 Kg	2.40 Kg
<b>DOSAGE RANGE</b>	<b>O<sub>2</sub></b> 0.1 - 1 L/min. 0.1 - 8 L/min. 0.2 - 15 L/min. <b>Air</b> 0.2 - 15 L/min. <b>N<sub>2</sub>O</b> 0.1 - 1 L/min. 0.2 - 12 L/min.			
<b>ACCURACY</b>	±10% read value or ±0.15 L/min. if greater (±10% E.O.S. value for flow E.O.S. ≤ than 1 L/min.)			
<b>INLET PRESSURES</b>	3.5 - 5 bar ±20%			
<b>CHARGE LOSS LEVEL, SIDE UNDER PRESSURE (BEFORE THE ADJUSTING NEEDLE VALVES)</b>	less than 25 ml/min. in normal pressure conditions (ISO 5358)			
<b>CHARGE LOSS LEVEL, LOW PRESSURE SIDE (AFTER THE ADJUSTING NEEDLE VALVES)</b>	less than 25 ml/min. at 30 cm H <sub>2</sub> O			
<b>MIXED GASES OUTLET CONNECTION</b>	Ø 22 M. - 15 F. ISO DIN 5356-1 or conical connection 23 mm F ISO DIN 5356/1 (for veterinary use only)			
<b>GASES INLET CONNECTIONS</b>	hose connector Ø 6 mm			

- 1 Gas adjusting knobs.
- 2 Inlet hose connectors, detail.



1



2

# EasyMIX<sup>®</sup>

Oxygen/air mixer



Excellence in **INNOVATION**  
Breakthrough **TECHNOLOGY**  
Intelligent **DESIGN**

The oxygen/air mixer type EasyMIX<sup>®</sup> is a single device that can be used in oxygen therapy, aerosol therapy and CPAP therapy with the possibility to constantly monitor the oxygen concentration present in the supplied mixture through an on-line oxygen analyzer (optional).

## STRUCTURE

The device is composed by two variable area flowmeter groups, one for oxygen with a dual scale 2-10 L/min. and 10-50 L/min. and one for medical air with scale 6-50 L/min, both assembled in a single body made of anodized aluminium equipped with a clamp for rail 30x10 mm with locking knob. The two independent inlet threads NIST EN ISO 5359, made of chrome-plated brass, allows a connection to the supply source through low pressure hose assemblies fitted with probes according to the user's plant and fixed in an unmovable way.

## POSSIBLE APPLICATIONS

The 2-in-1 connector for the mixture outlet offers several solutions:

- the thread 9/16" UNF EN 13544-2 M. allows to screw a reusable, single patient or prefilled humidifier;
- a connector with diameter 22 M. ISO DIN 5356-1 allows the connection to a system for the CPAP therapy, through a corrugated hose;
- a metal hose connector  $\varnothing 6.0 \div 8.5$  mm, already supplied with the device, for a direct connection to the patient hose (nose catheter or hose with mask).

A single device able to satisfy different use requirements in the field of the respiratory therapy.

## Main information



The optional analyser allows to constantly monitor the oxygen concentration present in the supplied mixture.



The EasyMIX<sup>®</sup> is a single device able to satisfy different use requirements in the field of the respiratory therapy.

## Related products



Low pressure hoses  
p. 161



Humidifiers  
from p. 47

<b>SIZES (LxWxH)</b>	110x130x157 mm
<b>WEIGHT</b>	1.0 Kg 1.2 Kg with Oxygen Analyzer (optional)
<b>SUPPLY MAX PRESSURE</b>	600 kPa (6 bar)
<b>GASES OPTIONS</b>	O <sub>2</sub> · Air
<b>STANDARD SCALES - 400 kPa (4 bar)</b>	O <sub>2</sub> dual scale 2-10 L/min. - 10-50 L/min. Air 6-50 L/min.
<b>ACCURACY</b>	±10% read value or ±0.5 L/min. if greater
<b>SUPPLY CONNECTIONS</b>	independent NIST EN ISO 5359
<b>MIXED GASES OUTLET CONNECTION</b>	9/16" UNF EN 13544-2 M. - $\varnothing$ 22 M. ISO DIN 5356-1 + an incorporated metal outlet hose connector $\varnothing 6.0 \div 8.5$ mm

- 1 Detail of **outlet with hose connector** (supplied with the device).
- 2 Detail of **outlet with corrugated hose**.
- 3 Detail of **EasyMIX®** with humidifier.
- 4 Detail of **dual scale for oxygen**.



▶ WATCH THE VIDEO



EasyMIX®



EasyMIX® with oxygen analyzer

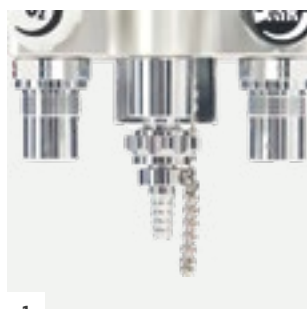

1



2



3



4

## Technical specifications | Oxygen analyzer

<b>SENSOR TYPE</b>	electrochemical
<b>RANGE OF MEASUREMENT</b>	0÷99% Vol. oxygen
<b>DISPLAY INDICATION</b>	1% Vol.
<b>MEASUREMENT TIME</b>	1 sec.
<b>RESPONSE TIME</b>	< 5 sec.
<b>ACCURACY</b>	±3% read value





EasyMIX® oxygen/air mixer  
with OXITER® oxygen therapy  
single-patient  
humidifiers

P. 124, 52

# EasyVEE®

Flow driver "jet"

The Jet device (Venturi unit) works as an high flow driver (booster) for high flow oxygen therapy through the use of HFNC or for CPAP, and it requires the gas supply from an Oxygen source only.

## STRUCTURE

The EasyVEE® Jet device is equipped with an inlet connection to be mounted on the outlet of the variable area flowmeter, working as a "driver" source for Venturi. The intake ambient air regulator, complete with connector Ø 22 F. - according to ISO DIN 5356-1, allows the adjustment of the oxygen concentration value (FiO<sub>2</sub>) of the mixture supplied to the patient. The Jet device gives the possibility to monitor constantly the oxygen concentration present in the supplied mixture through an on-line oxygen analyser (optional), connected to the FiO<sub>2</sub> monitor port. On the head of the device a quick dial nut allows the operator to select the function O<sub>2</sub>-Air (MIX) or 99% O<sub>2</sub>, this last one is foreseen to ventilate patient with high flows of Oxygen only. The mixture outlet connector (Ø 22 M - 16 F) made in accordance with Standard ISO DIN 5356-1 enables to add an on-line antimicrobial filter assuring a protection for the patient and reducing the noise of the system, thus giving a higher comfort during the therapy.

## APPLICATIONS

- **Application for single high flow flowmeter:** flow range 50 L/min. with double scale: 2÷10 L/min. and 10÷50 L/min.
- **Application for twin high flow flowmeter:** flowmeter [A] with end of scale 30 L/min.; flowmeter [B] with end of scale 15 L/min. or 30 L/min.

<b>SIZES (LxWxH)</b>	150x100x55 mm
<b>WEIGHT</b>	0.35 Kg 0.55 Kg with oxygen analyzer (optional)
<b>SUPPLIED GAS</b>	O <sub>2</sub>
<b>SUPPLIED STANDARD PRESSURE</b>	400 kPa (4 bar) +/- 10%
<b>FI<sub>2</sub> ADJUSTMENT</b>	from 35% to max 99%
<b>OXYGEN SUPPLY CONNECTION</b>	9/16" UNF EN 13544-2 F.
<b>INLET CONNECTION FOR THE INTAKE AMBIENT AIR</b>	Ø22 F. ISO DIN 5356-1
<b>OUTLET CONNECTION</b>	Ø22 M. - 16 F. ISO DIN 5356-1



Excellence in **INNOVATION**  
Breakthrough **TECHNOLOGY**  
Intelligent **DESIGN**

## Main information



For CPAP application, this device must be used only for the ventilation with the specific mask or with hood. It requires a PEEP valve placed on the outlet of the expiratory side.

## Related products



**Rs**  
variable area oxygen  
flowmeters  
p. 24

- 1 Intake ambient air inlet with adjustable knob.
- 2 Quick dial nut allows the operator to select the function O<sub>2</sub>-Air (MIX) or 99% O<sub>2</sub>.
- 3 FiO<sub>2</sub>+ port.
- 4 FiO<sub>2</sub> monitor port with analyzer (see next page).



▶ WATCH THE VIDEO



Download the app **EasyVEE®**



The App provides the healthcare professional with all guidelines to set the required flows for the ongoing respiratory therapy.



1



2



3



4

## Technical specifications | Oxygen analyzer

<b>SENSOR TYPE</b>	electrochemical
<b>RANGE OF MEASUREMENT</b>	0÷99% Vol. oxygen
<b>DISPLAY INDICATION</b>	1% Vol.
<b>MEASUREMENT TIME</b>	1 sec.
<b>RESPONSE TIME</b>	< 5 sec.
<b>ACCURACY</b>	±3% read value

## CLINICAL APPLICATION

The aim of the pressure gradient is to:

- Ensure a greater opening of the alveoli during inspiration
- Prevent alveolar collapse at the end of expiration, by maintaining a PEEP level
- Reduce the effort necessary to breathe, thus avoiding hypoxemia, hypercapnia, metabolic and respiratory acidosis typical of IRDS.

The JET system is mainly indicated for:

- Acute respiratory distress syndrome (ARDS)
- Severe respiratory distress
- Post-surgery hypoxemia
- Asthma
- Chronic obstructive pulmonary disease (COPD)
- Thoracic trauma
- Prophylaxis and treatment of acute apnoea attacks
- Pulmonary oedema and atelectasis of varying origins, and for weaning from a mechanical ventilator.

CPAP respiration, applied with any method, requires the patient's efficient spontaneous respiration (cases with frequent apnoea, or severe respiratory failure, require ventilator support).

To the patient is administered a gaseous mixture, with an appropriate concentration of O<sub>2</sub>, metered in L/min. by one or two oxygen flow meters, and the CPAP is obtained by discharging through a respiratory circuit terminal (PEEP valve), the expired gases.



EasyVEE®  
twin flowmeter



EasyVEE® single flowmeter

Single high flow flowmeter driver (flow range 50 L/min. with double scale: 2÷10 L/min. and 10÷50 L/min.) **A**

Jet Device (Venturi): works as a high flow driver (booster) for the non-invasive ventilation **B**

Quick dial nut to select the function O<sub>2</sub>-Air (MIX) or 99% O<sub>2</sub> **C**

The connector for the intake ambient air with adjustable knob **D**

On-line oxygen analyzer (optional) **E**

### OTHER SUPPLIER:

Antimicrobial filter **F**

Hood (or facial mask) for CPAP **G**

PEEP valve **H**



EasyVEE®  
twin flowmeter  
with oxygen analyzer



EasyVEE® single flowmeter  
with oxygen analyzer

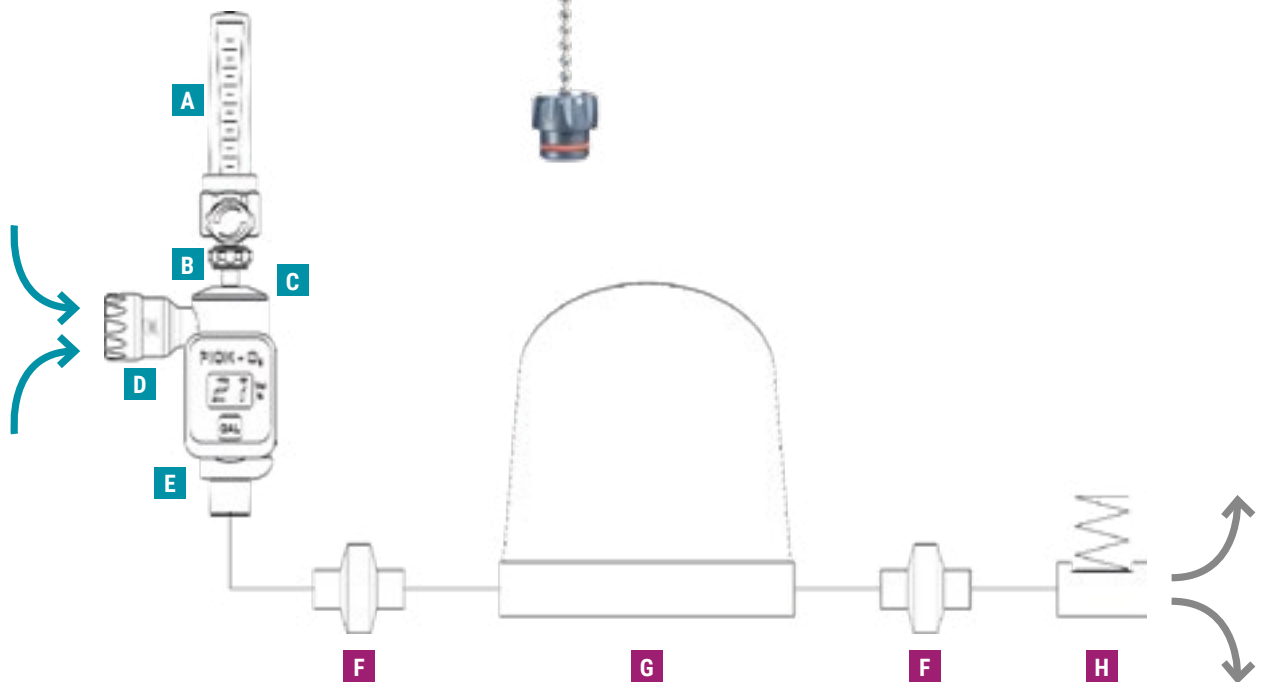

Download the app **EasyVEE®**



The App provides the healthcare professional with all guidelines to set the required flows for the ongoing respiratory therapy.







EasyVEE®  
flow driver "jet"

P. 128

# RM

## Flowmeters

The flowmeters type RM/185-2 are devices for the supply of medical gases with two meters suitable in respiratory therapy.

### STRUCTURE

The measurement tubes are made in the body of the unit and the inlet connections are at the bottom of the units and arranged to be connected to the hospitals centralized gas plants or to gas cylinders completed with pressure regulators. For veterinary use, an anesthesia evaporator can be connected at the outlet of the dosage unit.

### Related products



Hoses and probes  
for various gases  
from p. 155

### RM/185-2

<b>SIZES (LxWxH)</b>	99x83x204 mm
<b>WEIGHT</b>	0.60 Kg
<b>DOSAGE RANGE O<sub>2</sub> · N<sub>2</sub>O · Air</b>	5 L/min. · 15 L/min. · 30 L/min. · 40 L/min.
<b>ACCURACY</b>	±10% read value or ±0.5 L/min. if greater
<b>INLET PRESSURES</b>	3.5 - 5 bar ±20%
<b>CHARGE LOSS LEVEL, SIDE UNDER PRESSURE (BEFORE THE ADJUSTING NEEDLE VALVES)</b>	less than 25 ml/min. in normal pressure conditions (ISO 5358)
<b>CHARGE LOSS LEVEL, LOW PRESSURE SIDE (AFTER THE ADJUSTING NEEDLE VALVES, VAPORIZER EXCLUDED)</b>	less than 25 ml/min. at 30 cm H <sub>2</sub> O
<b>MIXED GASES OUTLET CONNECTION</b>	Ø 22 M. - 15 F. ISO DIN 5356-1 or conical connection 23 mm F ISO DIN 5356/1 (for veterinary use only)
<b>GASES INLET CONNECTIONS</b>	hose connector Ø 6 mm

1 Adjusting knobs.



1

# O<sub>2</sub>+

## Flush device

The O<sub>2</sub>+ flush device is suitable for a quick oxygen supply directly at the mixed gases outlet at the end of an anesthesia circuit.

### STRUCTURE

Made of anodized aluminum, it is equipped with an anesthetic mixture inlet connection, an oxygen enriched mixture outlet connection, an O<sub>2</sub> feeding connection and a supply button. Different constructions can be made on request.

### Related products



SF  
flowmeters  
p. 122

**SIZES (LxWxH)** 93x63x80 mm

**WEIGHT** 0.34 Kg

**MIXED GASES INLET CONNECTION** conical connection 23 mm M., ISO DIN 5356/1

**MIXED GASES OUTLET CONNECTION** conical connection 23 mm F., ISO DIN 5356/1

**FEEDING** 3.5 - 5 bar ±20%

**O<sub>2</sub> FEEDING CONNECTION** automatic type for Ø 6 mm PA hose

**O<sub>2</sub> QUICK SUPPLY** when pushed it can supply more than 45 L/min. O<sub>2</sub> (at 3.5 bar)

- 1 Inlet connection in detail.
- 2 O<sub>2</sub>+ flush button, detail.
- 3 Outlet and O<sub>2</sub>+ feeding connectors, detail.



1



2



3



# TERMINAL UNITS

DEVICES & COMPONENTS

As terminal units are intended those fixed or removable points of a medical **gas distribution plant** on which the user operates frequent connections and disconnections to supply the various gases for feeding the anesthesia equipment, for ventilation, oxygen therapy and medical use in general. There are also available the terminal units in special version for scavenging system.

#### STANDARDS

These terminal units are designed and manufactured in accordance with various national and international standards providing operators with high standards of safety during the use.



hospitals



emergency



home care



#### UNI 9507 outlets

Flush-mounted installation with UNI 9507 outlets  
(surface installation also available).

# Terminal Units

The terminal units for medical compressed gases and vacuum are the points allowing operators in hospitals to connect medical appliances to the gas distribution systems.

#### MAIN FEATURES

- Gas-specificity to grant safe connections
- Color code according to international standards
- Available in construction of 1 to 4 units
- According to AFNOR NF-S 90-116/NF-DS 90-119, NIST EN ISO 5359, UNI 9507, DIN 13260, BS 5682, SS 875 24 30 standards
- Possibility of surface or flush mounted installation.



**DIN 1326 outlets**

Flush-mounted installation with DIN 1326 outlets (surface installation also available).

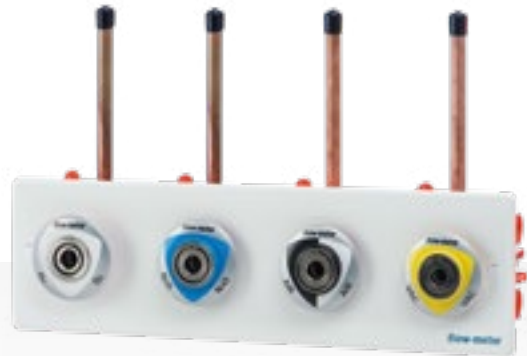

**BS 5682 outlets**

Flush-mounted installation with BS 5682 outlets (surface installation also available).

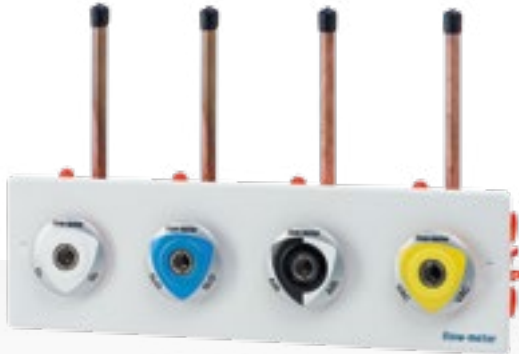

**SS 875 24 30 outlets**

Flush-mounted installation with SS 875 24 30 outlets (surface installation also available).



**AFNOR NF-S 90-116/NF-DS 90-119/  
NIST EN ISO 5359 outlets**

Flush-mounted installation with AFNOR NF-S 90-116/NF-DS 90-119/NIST EN ISO 5359 outlets (surface installation also available).



**AFNOR NF-S 90-116/  
NF-DS 90-119/NIST EN ISO 5359 outlets**  
Surface installation with AFNOR NF-S 90-116/  
NF-DS 90-119/NIST EN ISO 5359 outlets.

## Wall cases

### Terminal units · Components



Modular flush-mounted case, complete with disposable panel, suitable for housing **AFNOR NF-S 90-116/ NF-DS 90-119, UNI 9507, DIN 13260, BS 5682** and **SS 875 24 30** sockets and outlets.



Shiny ABS cover panel for modular flush-mounted cases for **AFNOR NF-S 90-116/NF-DS 90-119, UNI 9507, DIN 13260, BS 5682** and **SS 875 24 30** type outlets. Available with 1, 2, 3 or 4 positions.



Surface mounted case, complete with varnished stainless steel cover panel, with 1, 2, 3 or 4 positions, suitable for housing **AFNOR NF-S 90-116/NF-DS 90-119, UNI 9507, DIN 13260, BS 5682** and **SS 875 24 30** sockets and outlets.



Gases identification labels for **AFNOR NF-S 90-116/ NF-DS 90-119/NIST EN ISO 5359** outlets, suitable for fitting on cover panels on modular flush-mounted cases or on surface-mounted cases.



Gases identification labels for **DIN 13260, BS 5682, SS 875 24 30** outlets, suitable for fitting on cover panels on modular flush-mounted cases or on surface-mounted cases.



Plasterboard rail for modular flush-mounted cases.

## Outlets

### Terminal units · Components



Outlet type **AFNOR NF-S 90-116/NF-DS 90-119** for compressed medical gases and vacuum available in the following construction:

- with gas specific thread UNI 9507
- with thread ISO G. 1/4" M.
- with hose connector Ø 6.0 mm for compressed medical gases and with hose connector Ø 7.5 mm for vacuum.



Outlet type **DIN 13260** for compressed medical gases and vacuum.



Outlet type **BS 5682** for compressed medical gases and vacuum.



Outlet type **NIST EN ISO 5359** for compressed medical gases and vacuum available in the following constructions:

- with gas specific thread UNI 9507
- with hose connector Ø 6.0 mm for compressed medical gases and with hose connector Ø 7.5 mm for vacuum.



Outlet type **SS 875 24 30** for compressed medical gases and vacuum.



Outlet type **UNI 9507 NEO** with access for simplified maintenance for compressed medical gases and vacuum available in the following constructions:

- with gas specific thread UNI 9507
- with hose connector Ø 6.0 mm for compressed medical gases and with hose connector Ø 7.5 mm for vacuum.



Outlet type **UNI 9507** with thread for medical gases and vacuum, equipped with parking device.

# Sockets

Terminal units · Components

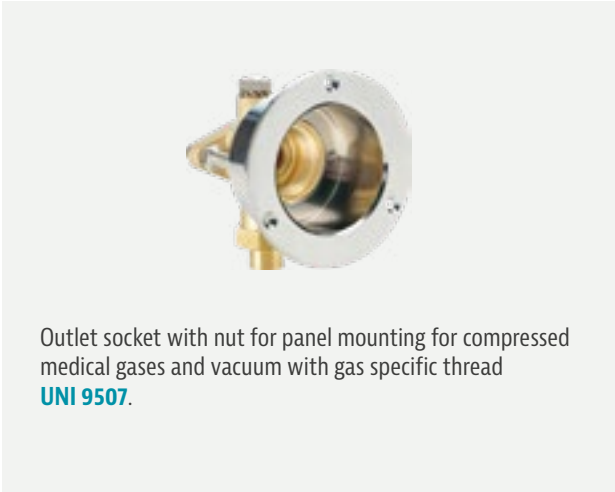

Outlet socket with nut for panel mounting for compressed medical gases and vacuum with gas specific thread **UNI 9507**.



Outlet socket for compressed medical gases and vacuum with gas specific thread **UNI 9507**, complete with nut and copper welding tube nipple.

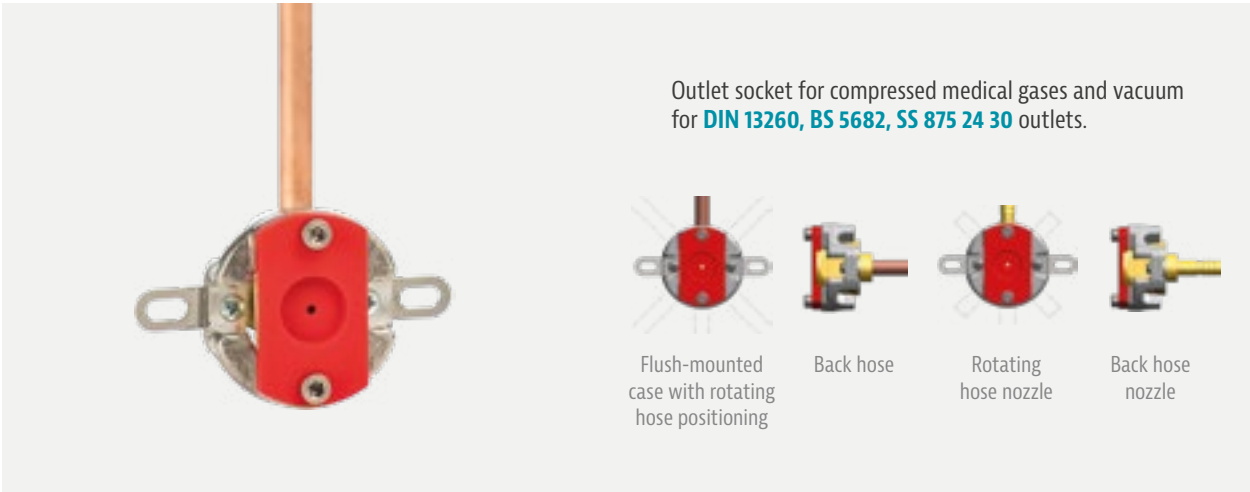

# Configurations

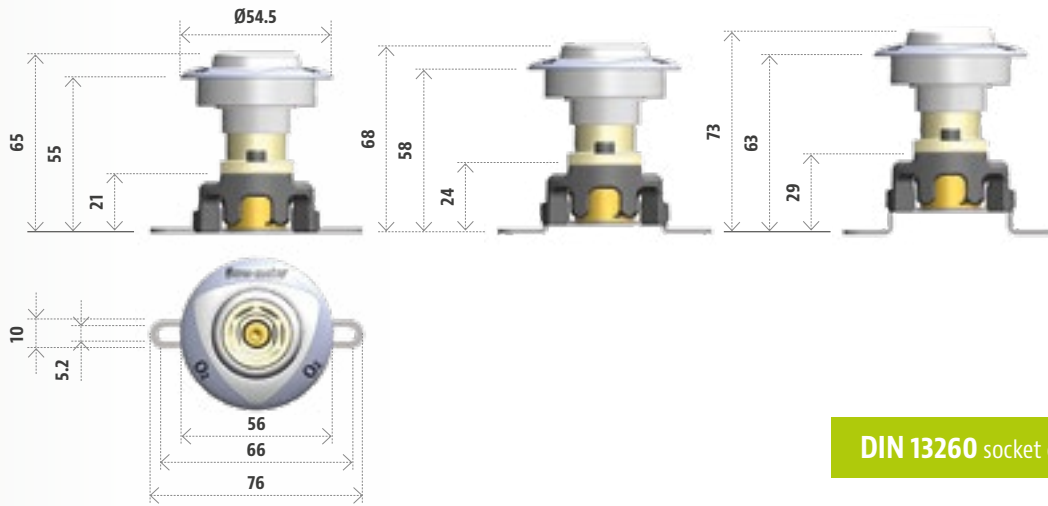

**DIN 13260** socket configuration

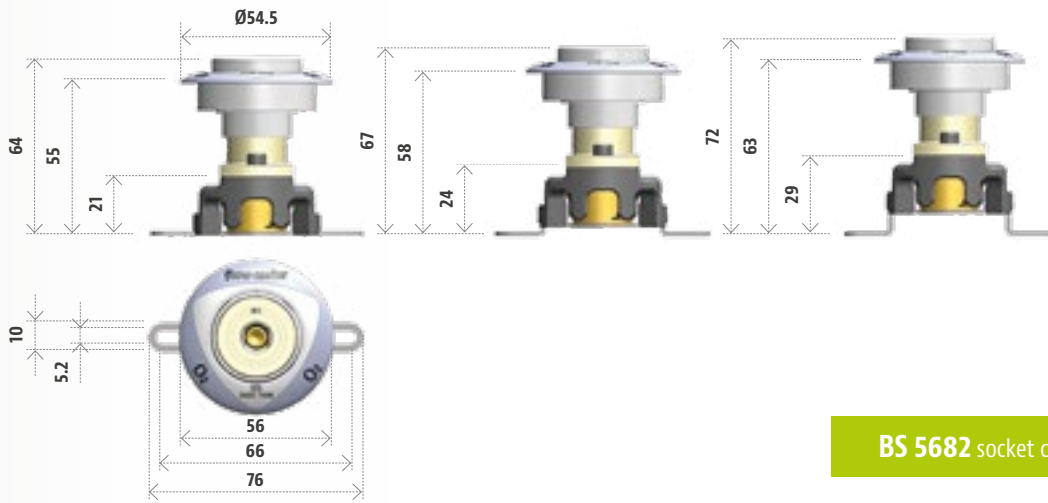

**BS 5682** socket configuration

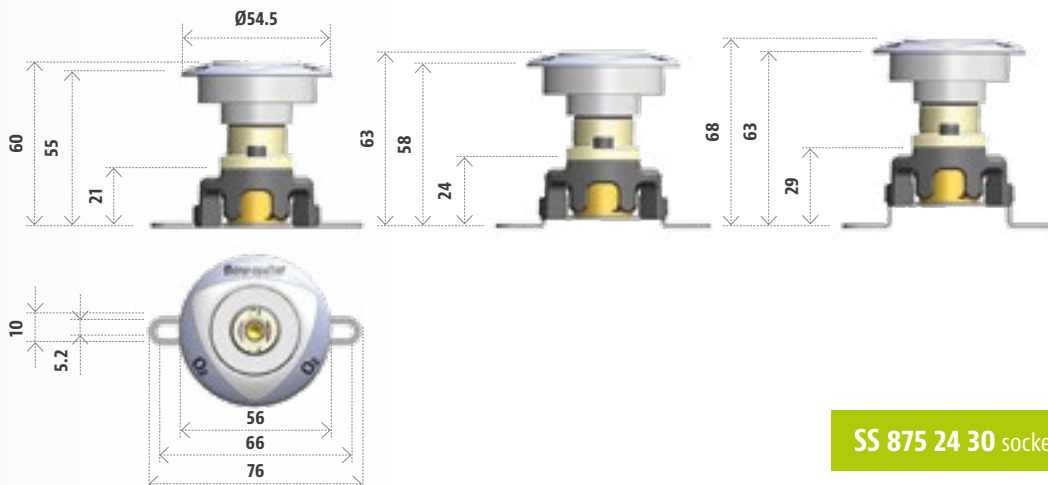

**SS 875 24 30** socket configuration

# Directory

Terminal units · **Flush-mounted** installation



## AFNOR NF-S 90-116/NF-DS 90-119/ NIST EN ISO 5359 outlets

### Directory · Components detail

- 1 Gas identification label for AFNOR NF-S 90-116/  
NF-DS 90-119/NIST EN ISO 5359 outlets
- 2 ABS panel for modular flush-mounted cases  
with screws
- 3 Outlet type AFNOR NF-S 90-116  
or NF-DS 90-119 or NIST EN ISO 5359
- 4 Socket with UNI 9507 thread
- 5 Modular flush-mounted case

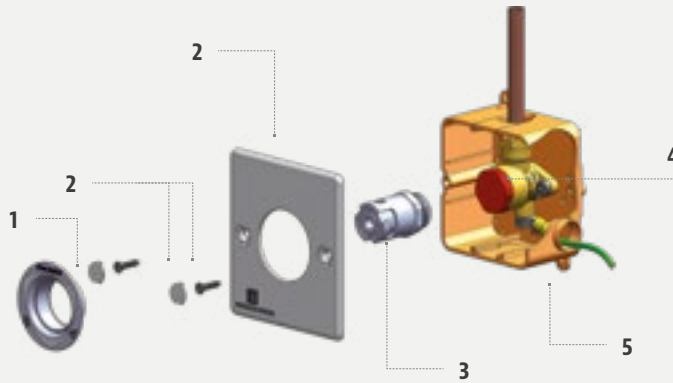

## UNI 9507 outlets

### Directory · Components detail

- 1 Outlet type UNI 9507
- 2 ABS panel for modular flush-mounted  
cases with screws
- 3 Socket with UNI 9507 thread
- 4 Modular flush-mounted case

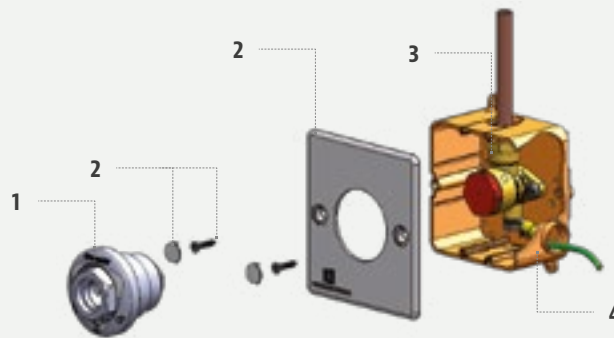

## DIN 13260, BS 5682, SS 875 24 30 outlets

### Directory · Components detail

- 1 Gas identification label for DIN 13260,  
BS 5682, SS 875 24 30 outlets
- 2 ABS panel for modular flush-mounted  
cases with screws
- 3 Outlet type DIN 13260 or BS 5682  
or SS 875 24 30
- 4 Socket for DIN 13260, BS 5682,  
SS 875 24 30 outlets
- 5 Modular flush-mounted case

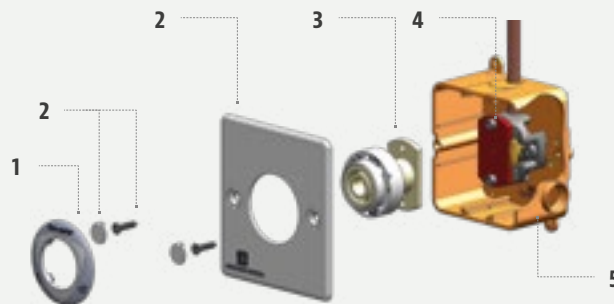

## Terminal units · Surface installation

### AFNOR NF-S 90-116/NF-DS 90-119/ NIST EN ISO 5359 outlets

#### Directory · Components detail

- 1 Gas identification label for AFNOR NF-S 90-116/ NF-DS 90-119/NIST EN ISO 5359 outlets
- 2 Surface mounted case with screws and spacers
- 3 Outlet type AFNOR NF-S 90-116 or NF-DS 90-119 or NIST EN ISO 5359
- 4 Socket with UNI 9507 thread

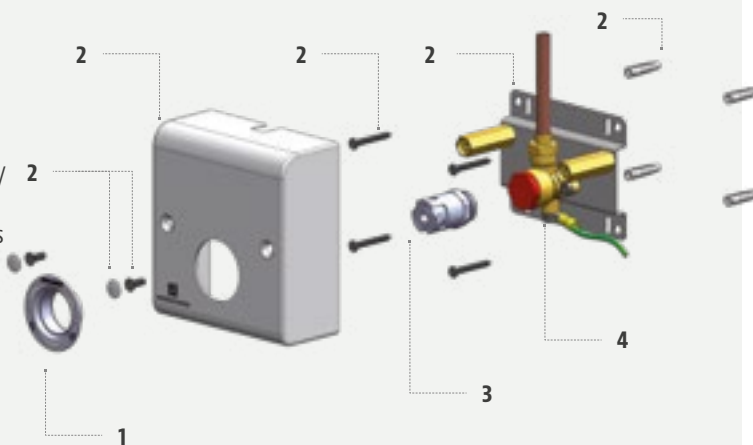

### UNI 9507 outlets

#### Directory · Components detail

- 1 Outlet type UNI 9507
- 2 Surface mounted case with screws and spacers
- 3 Socket with UNI 9507 thread

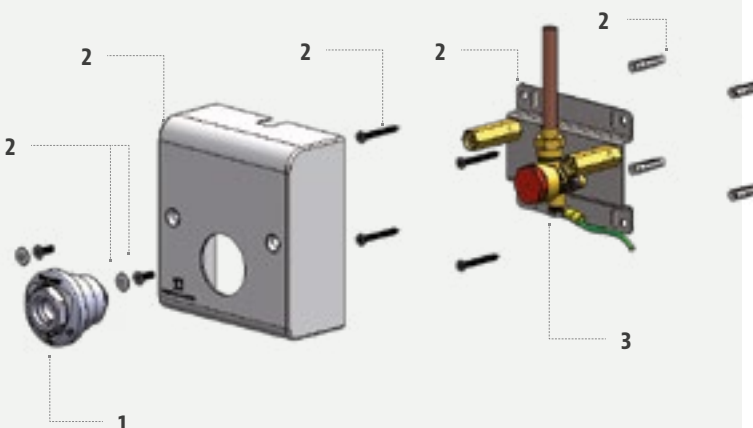

### DIN 13260, BS 5682, SS 875 24 30 outlets

#### Directory · Components detail

- 1 Gas identification label for DIN 13260, BS 5682, SS 875 24 30 outlets
- 2 Surface mounted case with screws and spacers
- 3 Outlet type DIN 13260 or BS 5682 or SS 875 24 30
- 4 Socket for DIN 13260, BS 5686, SS 875 24 30 outlets

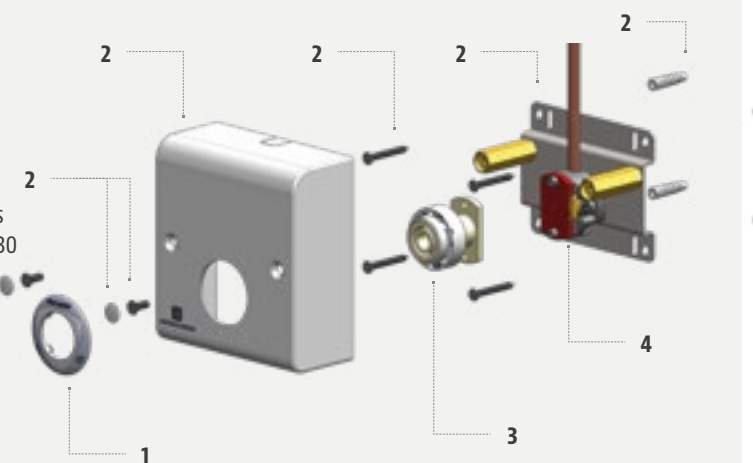

# EN ISO 9170-2 AGSS type 1

Terminal units

The EN ISO 9170-2 AGSS type 1 terminal units for anesthetic gas scavenging systems are the points allowing operators in hospitals to connect the appropriate quick couplings to safely dispose the exceeding anesthetic gases and vapors away from the clinical environment.

## SOLUTIONS AND OPTIONS

The main purpose is to minimize the pollution of the premises where anesthetics are used. Two main installation principles are available:

**Venturi type** | The suction system is based on the Venturi principle, on the basis of which an injector supplied with compressed air at a pressure of 4 bar, produces a constant suction (set by the installer) suitable for discharging anaesthetic gases outside the room where they are used.

**Blower type** | A blower generates a constant suction inside the centralized suction system designed to eliminate the anaesthetic gases from the room where they are used; the installer can also adjust the flow discharged directly on the base block by means of a variable section connector.

## Main information



Two main installation principles are available: Venturi type and Blower type.



Flush-mounted installation

Surface installation



ACCESSORIES

**TERMINAL UNITS**

FLOWMETER UNITS

PRESSURE REGULATORS  
AND FLOWMETERS  
FOR ALL MEDICAL GASES

SUCTION OF FLUIDS

OXYGEN THERAPY

## Components

### EN ISO 9170-2 AGSS type 1



Painted stainless steel cover panel, for flush-mounted case for **EN ISO 9170-2 AGSS type 1** outlet with front access for the outlet simplified calibration.



Flush-mounted case, complete with disposable panel, suitable for housing **EN ISO 9170-2 AGSS type 1** sockets and outlet.



**EN ISO 9170-2 AGSS type 1** outlet.



#### Venturi type

Socket for **EN ISO 9170-2 AGSS type 1** outlet with Venturi system. An injector supplies compressed air at 4 bars creating a constant suction (the setting value can be adjusted during installation) suitable to eliminate the anesthetic gases from the area where they are used. Front access for the simplified calibration without need to disassemble the outlet or to open the cover panel.

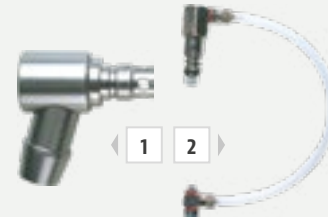

**1** Probe for **EN ISO 9170-2 AGSS type 1** outlet.

**2** Pneumatic gauge indicating the terminal unit status, to be connected to the socket of the **EN ISO 9170-2 AGSS type 1** outlet with Venturi system.



#### Blower type

Socket for **EN ISO 9170-2 AGSS type 1** outlet for blower. A blower generates a constant suction inside the central system for the scavenging of anesthetic gases from the area where they are used. The flow can be adjusted during the installation directly on the socket by means of a variable section connector.



Surface mounted case, complete with varnished stainless steel cover panel, suitable for housing **EN ISO 9170-2 AGSS type 1** sockets and outlets with front access for the outlet simplified calibration.

# Directory

## EN ISO 9170-2 AGSS type 1 · Flush-mounted and surface installation

### EN ISO 9170-2 AGSS type 1 outlet with Venturi system FLUSH-MOUNTED INSTALLATION

#### Directory · Components detail

- 1 EN ISO 9170-2 AGSS type 1 outlet
- 2 S/S cover panel with screws
- 3 Pneumatic gauge
- 4 Socket for EN ISO 9170-2 AGSS type 1 outlet with Venturi system
- 5 Flush-mounted case

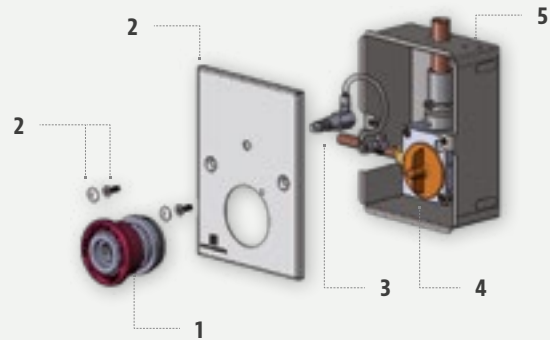

### EN ISO 9170-2 AGSS type 1 outlet for blower FLUSH-MOUNTED INSTALLATION

#### Directory · Components detail

- 1 EN ISO 9170-2 AGSS type 1 outlet
- 2 S/S cover panel with screws
- 3 Socket for EN ISO 9170-2 AGSS type 1 outlet for blower
- 4 Flush-mounted case

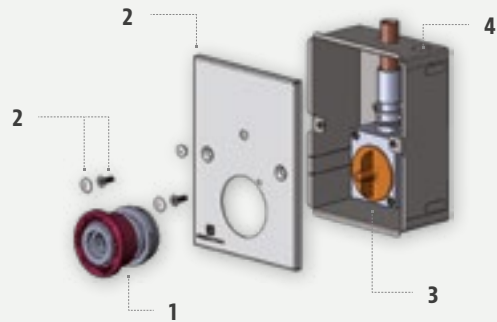

### EN ISO 9170-2 AGSS type 1 outlet with Venturi system SURFACE INSTALLATION

#### Directory · Components detail

- 1 EN ISO 9170-2 AGSS type 1 outlet
- 2 Surface mounted case with screws and spacers
- 3 Pneumatic gauge
- 4 Socket for EN ISO 9170-2 AGSS type 1 outlet with Venturi system

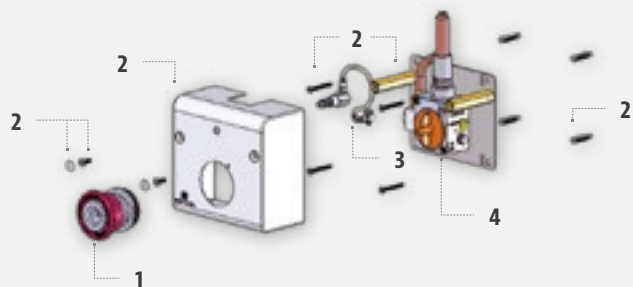

### EN ISO 9170-2 AGSS type 1 outlet for blower SURFACE INSTALLATION

#### Directory · Components detail

- 1 EN ISO 9170-2 AGSS type 1 outlet
- 2 Surface mounted case with screws and spacers
- 3 Socket for EN ISO 9170-2 AGSS type 1 outlet for blower

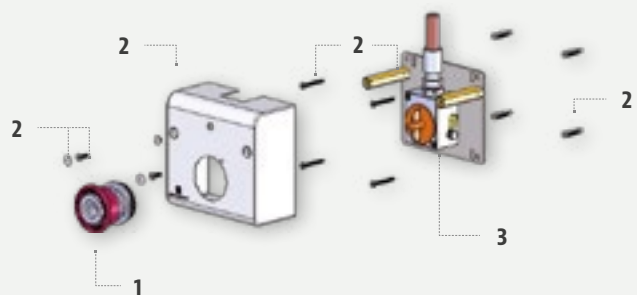



# ACCESSORIES

RAILS, FIXING DEVICES, PHLEBOCLYSIS RODS, JOINTED EXTENSION,  
LOW PRESSURE HOSE ASSEMBLIES

The range of accessories includes a wide variety of clamp brackets for rail or floor stands, ABS wall brackets with various slide dimensions, brushed stainless steel rails complete with spacers and wall or plasterboard fasteners, medical gas hoses EN ISO 5359, catheter containers, jointed extensions and phleboclysis rods.

#### APPLICATIONS

These accessories give the possibility to complete the proposals offering the best solutions for the customer requirements, according to the different using needs in hospitals and in emergencies.



hospitals



emergency



home care

## Probes with thread connection



Probe type **AFNOR NF-S 90-116** with thread ISO G. 1/4" F.



Probe type **AFNOR NF-S 90-116 EASYFIX®** with thread ISO G. 1/4" F.



Probe type **UNI 9507** with thread ISO G. 1/4" F.



Probe type **BS 5682** with thread ISO G. 1/4" F.



Probe type **DIN 13260** with thread ISO G. 1/4" F.



Probe type **SS 875 24 30** with thread ISO G. 1/8" M. or ISO G. 1/4" F.



Probe type **JIS T 7101** with thread ISO G. 1/8" M.



Probe type **SANS 1409** with thread ISO G. 1/4" F.



Probe type **OHMEDA** with thread ISO G. 1/4" F.

## Probes with hose connection



Probe type **AFNOR NF-S 90-116 EASYFIX®** for compressed medical gases with hose connector Ø 6 mm and for Vacuum with hose connector Ø 7.5 mm.



Probe type **UNI 9507** for compressed medical gases with hose connector Ø 6 mm and for Vacuum with hose connector Ø 7.5 mm.



Probe type **NIST EN ISO 5359** for compressed medical gases with hose connector Ø 6 mm and for Vacuum with hose connector Ø 7.5 mm.



Probe type **BS 5682** for compressed medical gases with hose connector Ø 6 mm and for Vacuum with hose connector Ø 7.5 mm.



Probe type **DIN 13260** for compressed medical gases with hose connector Ø 6 mm and for Vacuum with hose connector Ø 7.5 mm.



Probe type **SS 875 24 30** for compressed medical gases with hose connector Ø 6 mm and for Vacuum with hose connector Ø 7.5 mm.



Probe type **JIS T 7101** for compressed medical gases with hose connector Ø 6 mm and for Vacuum with hose connector Ø 7.5 mm.



Probe type **SANS 1409** for compressed medical gases with hose connector Ø 6 mm and for Vacuum with hose connector Ø 7.5 mm.



Probe type **OHMEDA** for compressed medical gases with hose connector Ø 6 mm and for Vacuum with hose connector Ø 7.5 mm.

## Outlet duplicators



Outlet duplicator type  
**AFNOR NF-S 90-116.**



Outlet duplicator type  
**NIST EN ISO 5359.**



Outlet duplicator type  
**UNI 9507.**

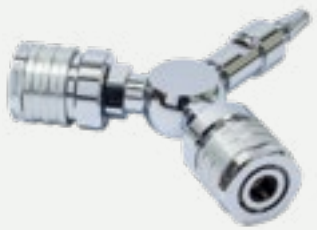

Outlet duplicator type  
**BS 5682.**



Outlet duplicator type  
**DIN 13260.**



Outlet duplicator type  
**SS 875 24 30.**

## Rail clamping system · Wall brackets · Stainless steel rail

### Rail clamping system



Universal bracket made of anodised aluminium for stand Ø 30 mm.



ABS clamp for rail 30x10 mm and 50x10 mm complete with nipple threaded ISO G. 1/4" F. and hose connector Ø 6 mm (for medical gases) or Ø 7.5 mm (for Vacuum).



ABS clamp bracket for rail 30x10 mm and 50x10 mm, with slide 25x5 mm, 30x5 mm or 45x5 mm.



Chrome-plated universal bracket for rail 30x10 mm with locking knob.



Chrome-plated universal bracket for rail 30x10 mm and 50x10 mm.



Anodized aluminum wedge for OHMEDA rail clamp bracket, with nipple threaded ISO G. 1/4" F. and hose connector Ø 6 mm (for medical gases) or Ø 7.5 mm (for vacuum).

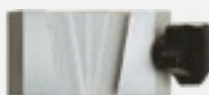

Anodized aluminum OHMEDA rail clamp bracket.



Anodized aluminum wedge for OHMEDA rail clamp bracket, with slide 25x5 mm, 30x5 mm or 45x5 mm.

< follows

## Rail clamping system · Wall brackets · Stainless steel rail

### Wall brackets



### Stainless steel rail



# Accessories



## Jointed extensions

**flow-meter™** jointed extension is a system particularly suitable to support the corrugated tubes of respiratory circuits.

The jointed extension is available with or without rail clamp bracket, with one or two joints allowing an easy orientation and with a device to fix two tubes Ø 16 mm or Ø 22 mm. Thanks to the swivel joints with cogging, it is an efficient support for even considerable weights.

### Sizes of sections | Type with:

<b>ONE JOINT</b>	First section: 150 mm - Second section: 450 mm
<b>TWO JOINTS</b>	First section: 150 mm - Second section: 450 mm Third section: 300 mm



## Phleboclysis rods

**flow-meter™** phleboclysis rods are support units particularly suitable to hold the infusion bottles during the hospital therapies. The phleboclysis rods allow an easy orientation and they can have the two following constructions:

- fixed construction, with straight or angled terminal piece and two hooks;
- extendible construction, with angled terminal piece and four hooks.

Thanks to the particularly strong structure made of chrome-plated steel, they can support even considerable weights.

Different constructions are produced under request.

# Low pressure hose assemblies

EN ISO 5359

The low pressure hose assemblies, meeting the requirements of the Standard EN ISO 5359, are indicated for the use with the following medical gases:

- Oxygen (O<sub>2</sub>);
- Medical air (AIR);
- Air for driving surgical tools (AIR-800);
- Vacuum (VAC).

Here under some examples of suggested uses for the flexible hose assemblies:

- Connection between terminal units and medical equipment (refer to Standards EN ISO 9170-1, EN ISO 80601-2-13 and EN ISO 80601-2-12);
- Connection between a distribution pipeline system and one of its terminal units (refer to Standards EN ISO 7396-1 and EN ISO 11197);
- Connection between two terminal units (refer to Standard EN ISO 7396-1);
- Connection between an emergency supply source and a supply point for the emergency and the maintenance of a distribution pipeline system (refer to Standards EN ISO 10524-1 and EN ISO 7396-1);
- Connection between an emergency supply point and a medical equipment (refer to Standards EN ISO 10524-1, EN ISO 80601-2-13 and EN ISO 80601-2-12).

## Main information



These flexible hose assemblies can be used in a pressure range from 300 kPa to 1400 kPa for compressed medical gases and from 10 kPa to 100 kPa (absolute pressure) for vacuum.

<b>COMPRESSED MEDICAL GASES HOSE SIZES</b>	Ø 11.5x5 mm
<b>VACUUM HOSE SIZES</b>	Ø 13.5x6.3 mm
<b>HOSE INNER MATERIAL</b>	black EPDM with antistatic treatment
<b>HOSE ARMOUR</b>	polyester
<b>HOSE COATING</b>	EPDM coloured according to the gas type
<b>COMPRESSED MEDICAL GASES WORKING PRESSURES</b>	from 300 kPa to 1400 kPa
<b>VACUUM WORKING PRESSURES</b>	from 10 kPa to 100 kPa (absolute pressure)
<b>STANDARD HOSE LENGTHS</b>	1.5 m, 2.5 m, 4.5 m for gases 1.5 m, 2.5 m for vacuum

- 1 Different configurations of probes and outlets and available for all medical gases.
- 2 Unamovable clamping system.



1



2



### Hoses for medical gases

Anti-squeezing hoses, according to standard EN ISO 5359, Ø 5x11.5 mm for medical compressed gases available in colors white, white-black and blue and Ø 6.3x13.5 mm for suction available in colors yellow and green.

**flow-meter™** means experience and qualified technical resources in continuous technological and normative evolution.

Marketing, Sales, R&D  
Medical and Industrial Line

Production  
Industrial Line

Warehouse  
Incoming and  
outgoing goods

Thanks to the prestigious collaboration of doctors, technicians and professionals able to dialogue and interact with each other, and using the highest quality standards for the realization of innovative medical devices, **flow-meter™** is today a recognized “**centre of excellence**” where continuous technological development plays an essential role in meeting the expectations of patients and health professionals.

An aerial photograph of a large facility, likely a hospital or medical center, during a sunset. The sky is filled with orange and yellow clouds, with the sun low on the horizon. In the foreground, there is a large green lawn with a winding path and a fenced-in tennis court. To the left, there are several buildings, including a large white one with a red roof. In the background, a city skyline is visible under the sunset sky. Two labels with white lines pointing to specific areas are present: 'Production Medical Line' pointing to a building on the left, and 'Recreation Area' pointing to a yellow square on the lawn.

Production  
Medical Line

Recreation Area

# flow-meter™

ENGINEERING REVOLUTION IN MEDICAL TECHNOLOGY



[flowmeter.it](http://flowmeter.it)

**Flow-Meter S.p.A.**

Via del Lino, 6 | 24040 Levate - Bergamo | ITALY

Ph. +39 035 594047 | Fax +39 035 594821

[info@flowmeter.it](mailto:info@flowmeter.it)

