

LIFE SCIENCE

DP75

Digital Microscope Camera

Empowering Microscopic Discoveries



One Camera. Multiple Applications.

The DP75 digital microscope camera is a high-performance, multi-application imaging tool that makes it easy to capture high-resolution brightfield or fluorescence images using a single camera. It simplifies your microscopy imaging, so you can focus more on your work.

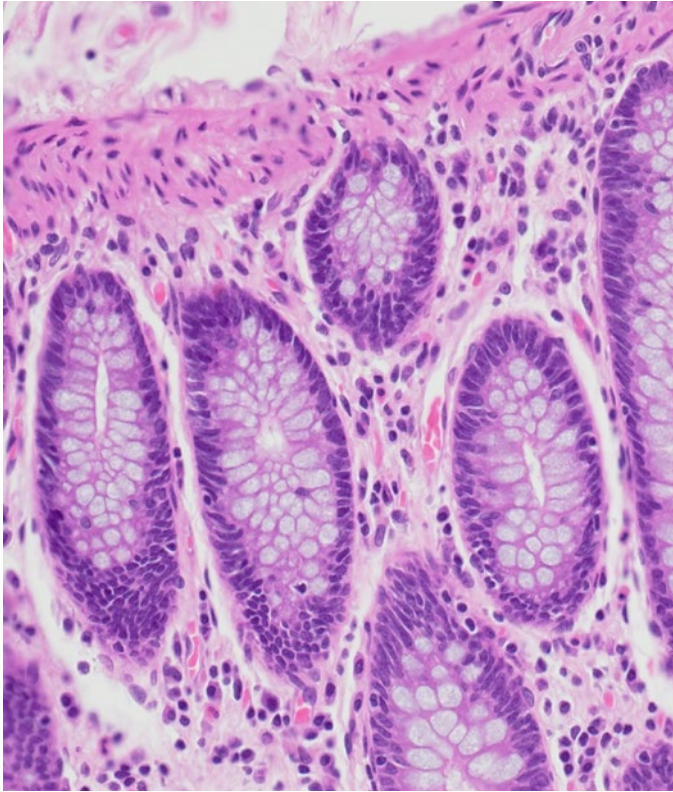

Colon. Stain: HE

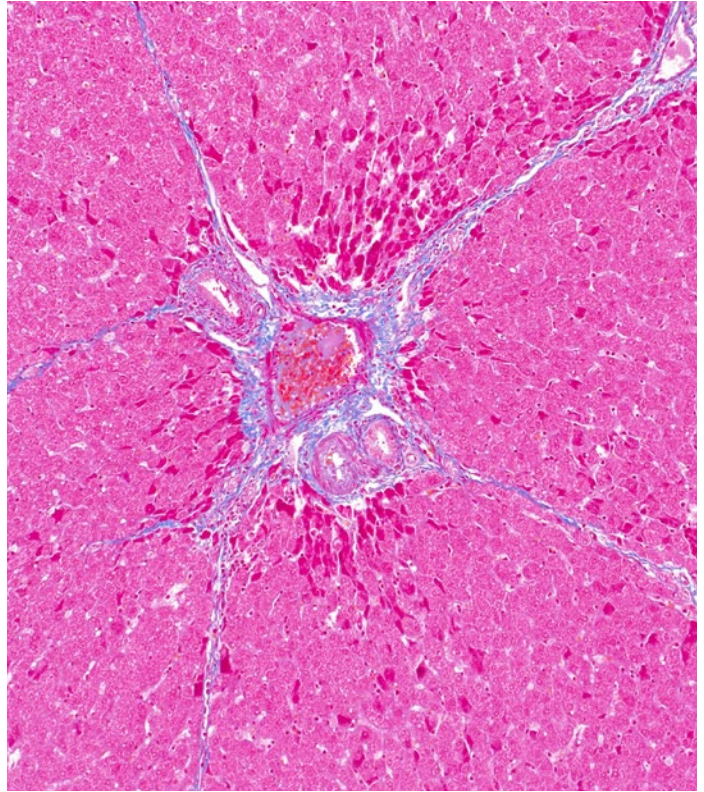

Pig liver. Stain: Masson trichrome

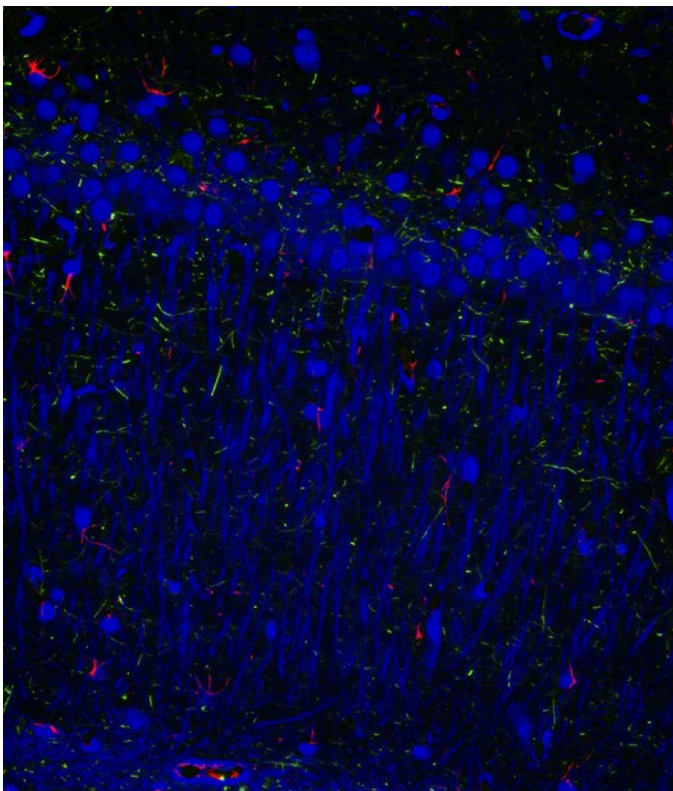

Rat brain. Stain: DAPI Alexa Fluor 555 Cy5

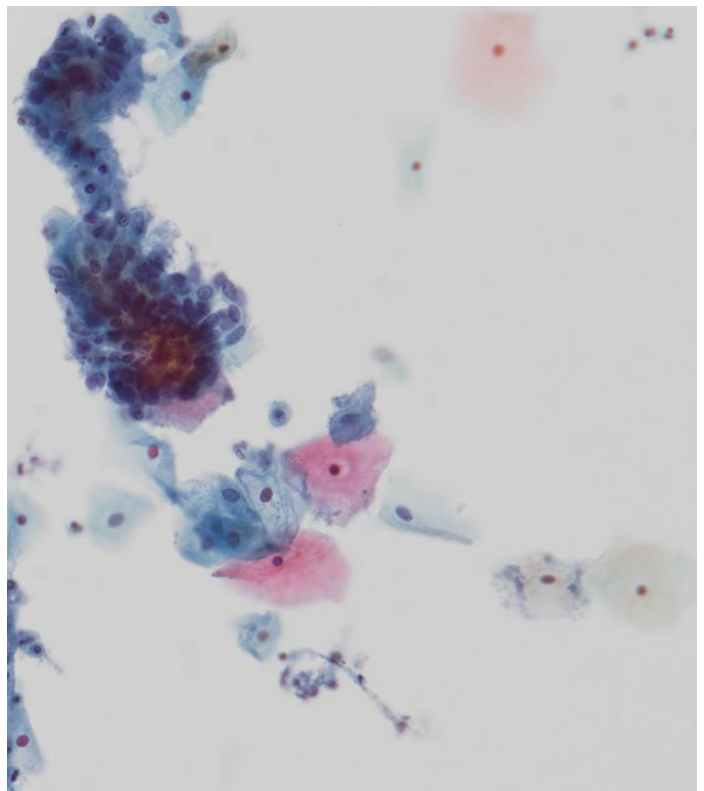

Cytology. Stain: ThinPrep

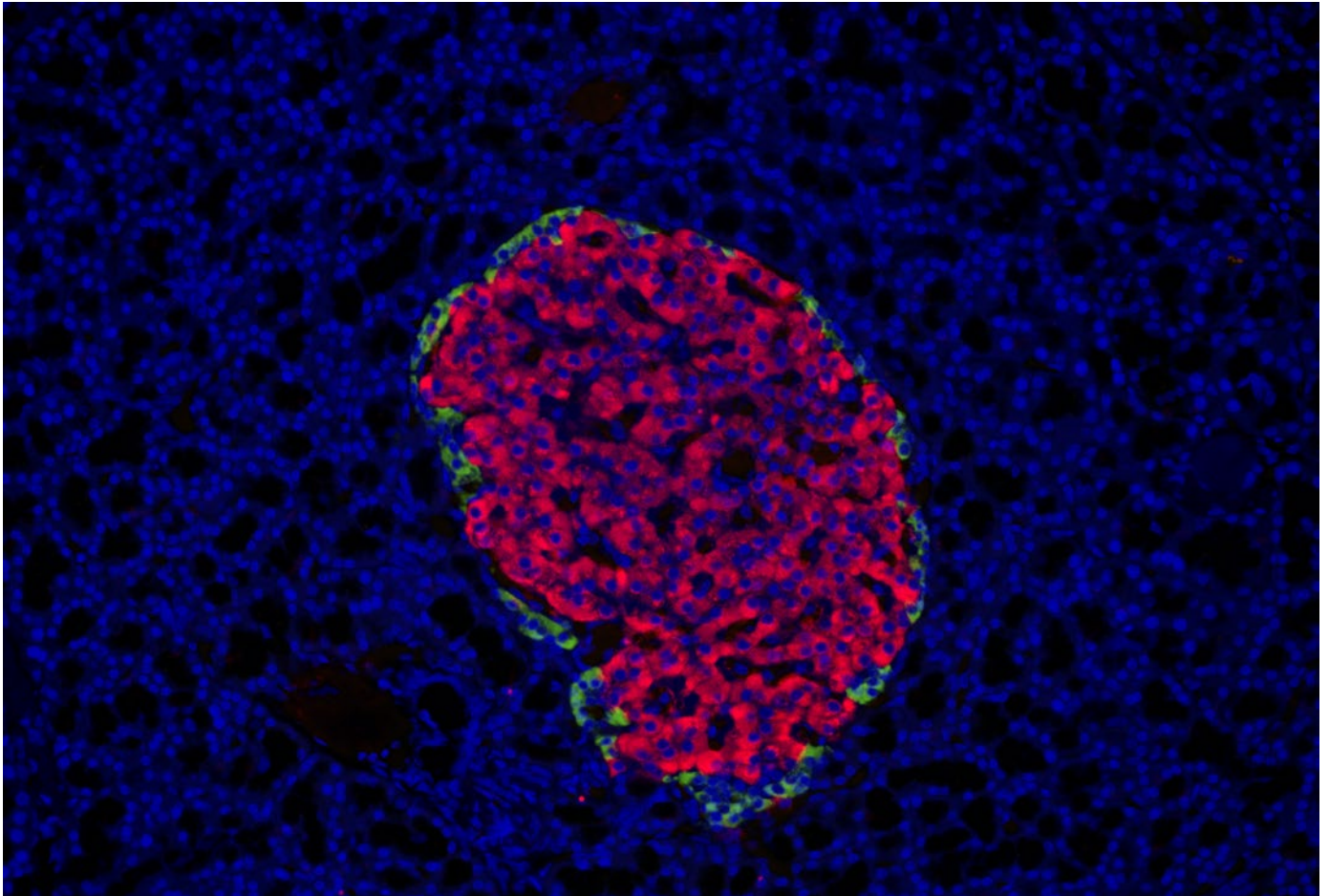

Rat Pancreas. Stain: DAPI AF555 Cy5

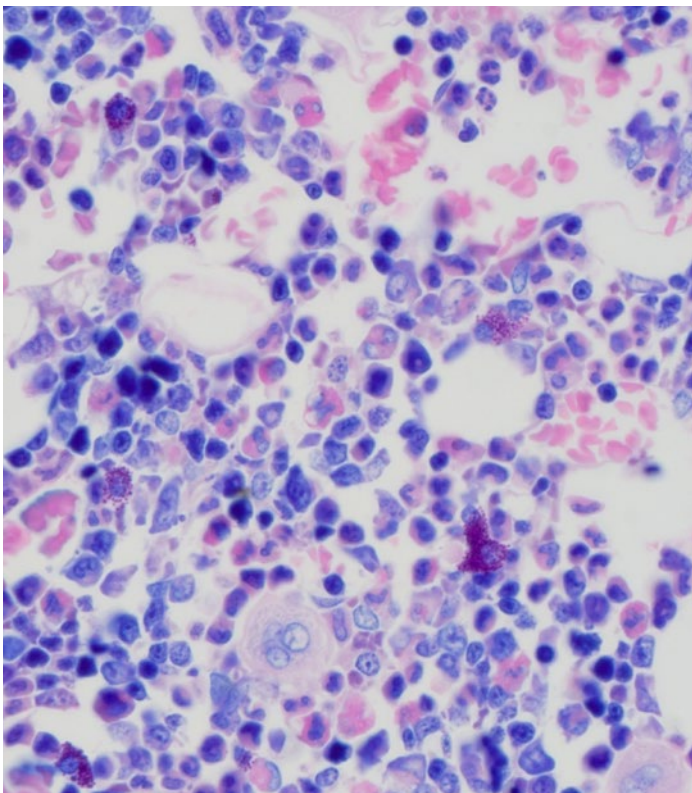

Rat marrow. Stain: Giemsa

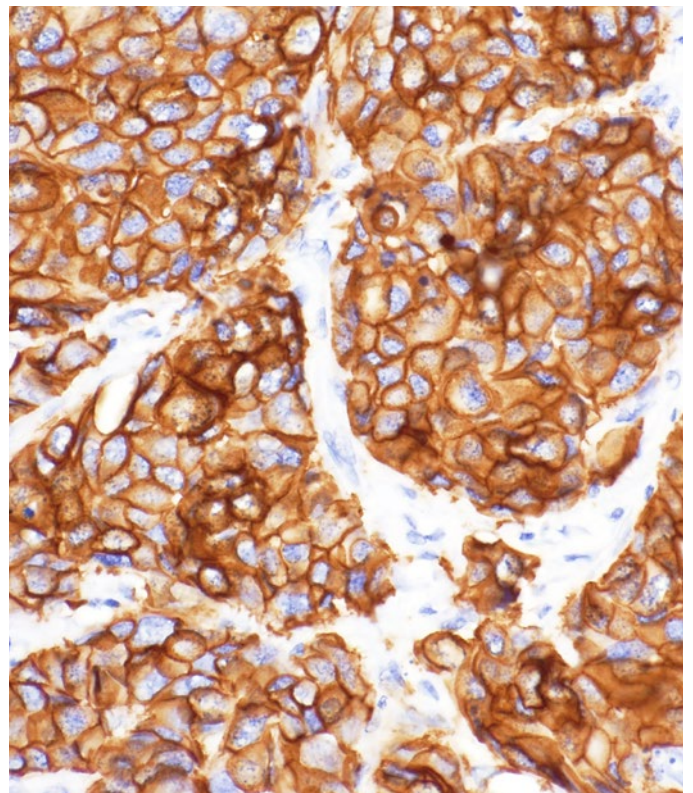

Mammary Gland. Stain: HER2

See More without Switching Cameras

With the DP75 digital microscope camera, there is no need for switching between color and monochrome cameras when you want to capture brightfield and fluorescence images. Now, you can capture both in outstanding quality using a single powerful camera.

Designed to excel in a wide variety of applications, the DP75 camera offers a high-sensitivity cooled CMOS sensor, fluorescence images up to Cy 7.5 via a switchable infrared (IR) cut filter, and high-resolution imaging, making it a versatile tool that is up to the challenge of modern imaging tasks.

Sharper Images, Clearer Insights

The DP75 camera makes it easier than ever to capture sharp, low-noise images. To push the image quality even further we integrated our real-time TruAI denoising algorithm into the camera. In addition, the DP75 maintains the high color fidelity our cameras are known for, delivering exceptional color reproduction and making your images as vivid as looking through the microscope oculars.

When imaging live specimens, a fast frame rate is important for efficiency and capturing the dynamics of your samples. With a fast frame rate of 22 frames per second (fps) at over 4K resolution and 60 fps at full HD resolution, the camera provides smooth, fast, live images for easy framing and comfortable live observation.

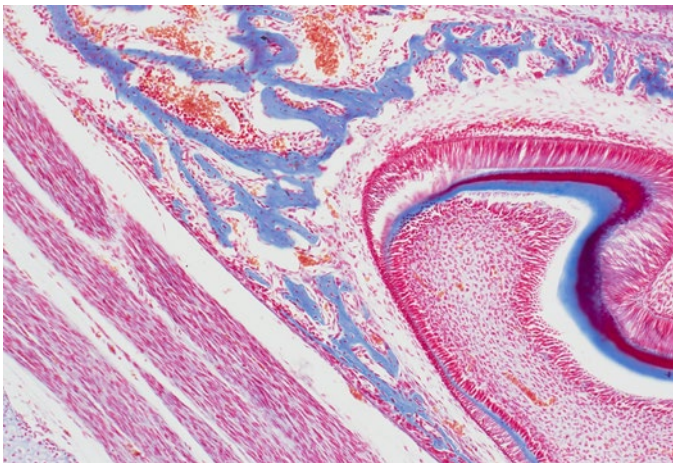

Mouse

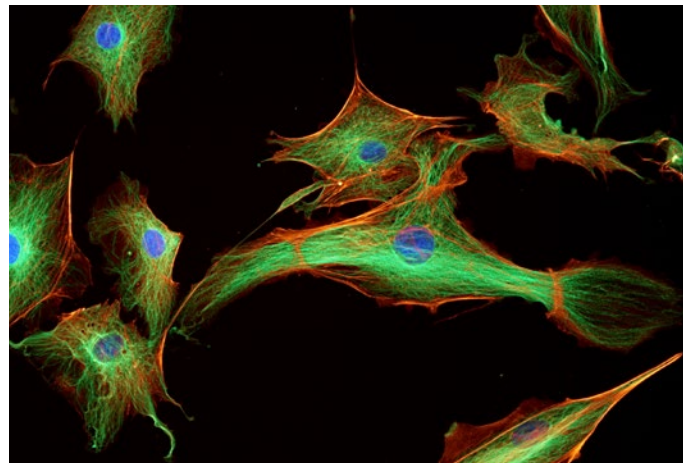

BPAE cells

High-Resolution, Wide Field of View Imaging

The camera's wide field of view capabilities enable you to find your target areas quickly, making your research more efficient. In addition, the DP75 camera enables you to capture high-resolution images even at low magnification with a maximum resolution of 8192 × 6000 through pixel shifting modes.

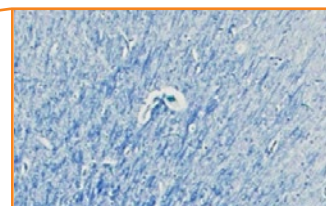
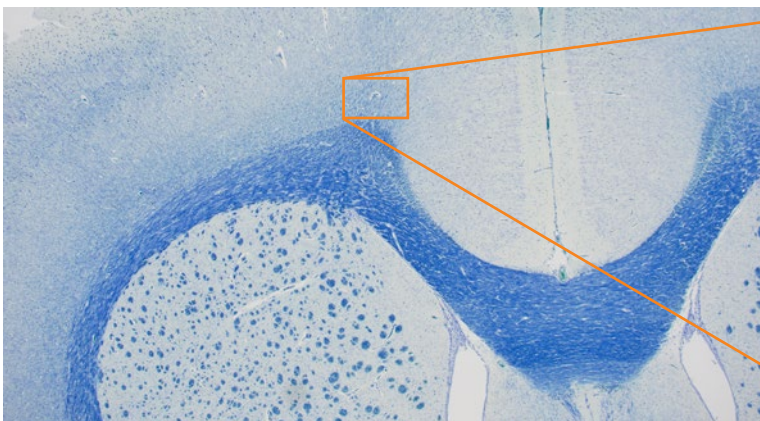

Without pixel shift

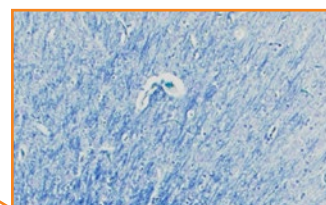

With pixel shift

Quantitative Image Data with Wide-Wavelength Fluorescence

If you are using reagents with infrared emission for multicolor fluorescence imaging, the DP75 camera will transform the way you capture images.

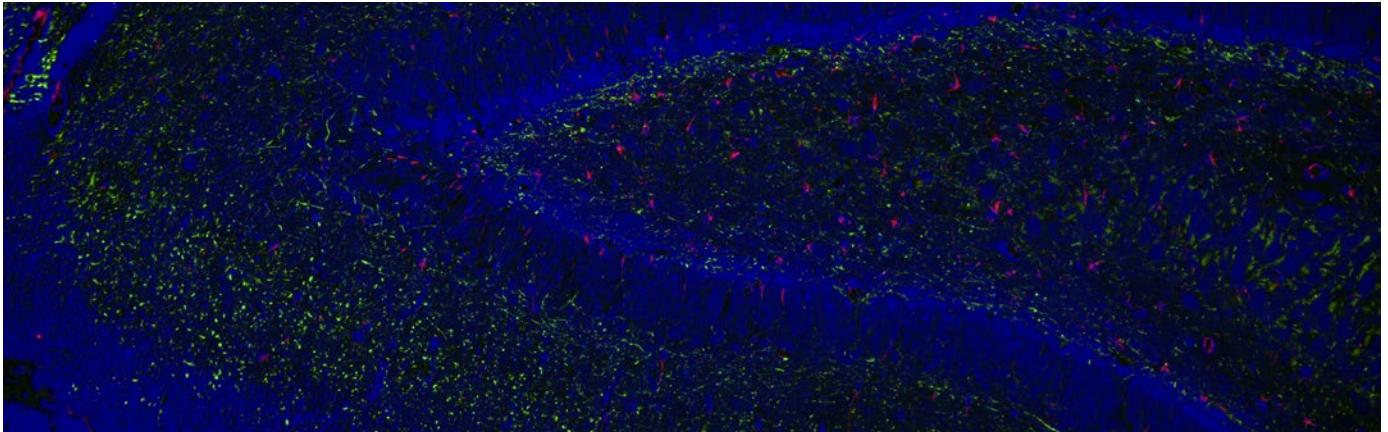

Rat brain. Stain: DAPI Alexa Fluor 555 Cy5

Infrared Fluorescence Imaging

The DP75 camera supports multiple staining combinations and wavelengths up to 1000 nm with a switchable IR cut filter. This setup enables you to—for example—check your sample conditions with your standard widefield microscope before spending time on a confocal microscope to finalize your imaging.

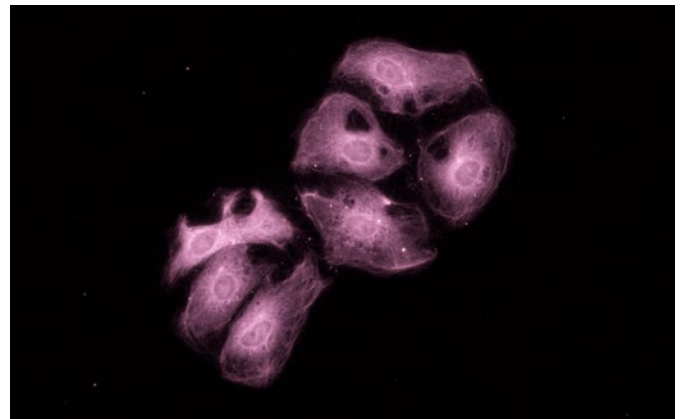

Ptk2. Stain: Cy7

Qualitative Analysis Capabilities

The camera's linear mode enables intensity analysis without needing a dedicated monochrome camera. You also can access raw RGB pixel values for quantitative data regarding staining density or brightness. Moreover, the camera enables you to easily overlay fluorescence and brightfield images with pixel precision since you are using the same sensor for brightfield and fluorescence. This enables you to precisely identify the location of fluorescent expression, helping you focus on the relevant morphology and localization of your specimen.

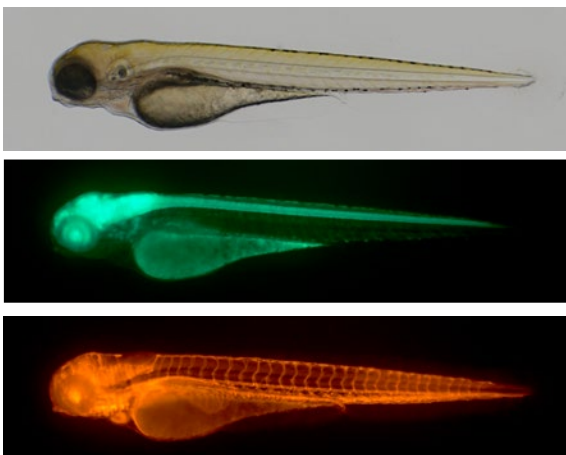

Original: brightfield and fluorescence images of a zebrafish



Overlaid image

Intelligent Features, Stunning Results

The DP75 camera can make your microscope observations more comfortable and efficient with smart features and AI support.

Smart Observation Detection

The AI-based scene detection feature automatically recognizes five observation methods (brightfield, fluorescence, phase contrast, differential interference contrast, and polarization), enabling anyone to obtain high-quality images with minimal training.

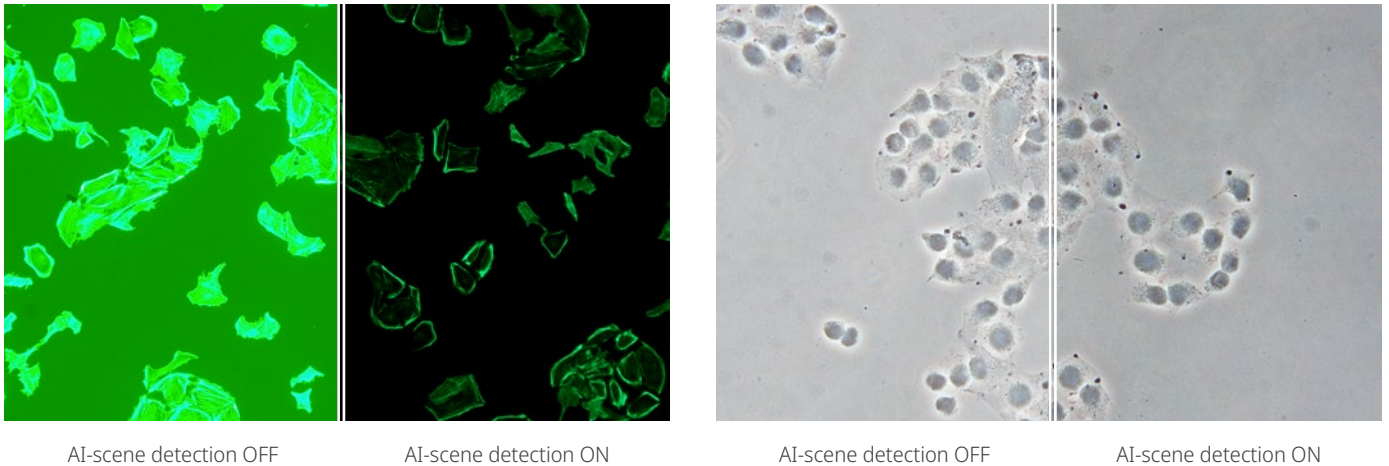

Multiple Image Alignment (MIA) Capabilities

The instant multiple image alignment (MIA) function simplifies the creation of wide-area images by moving the XY stage manually without any motorized setup, and the integrated position navigator helps ensure that you always know your position on the sample during brightfield and fluorescence imaging.

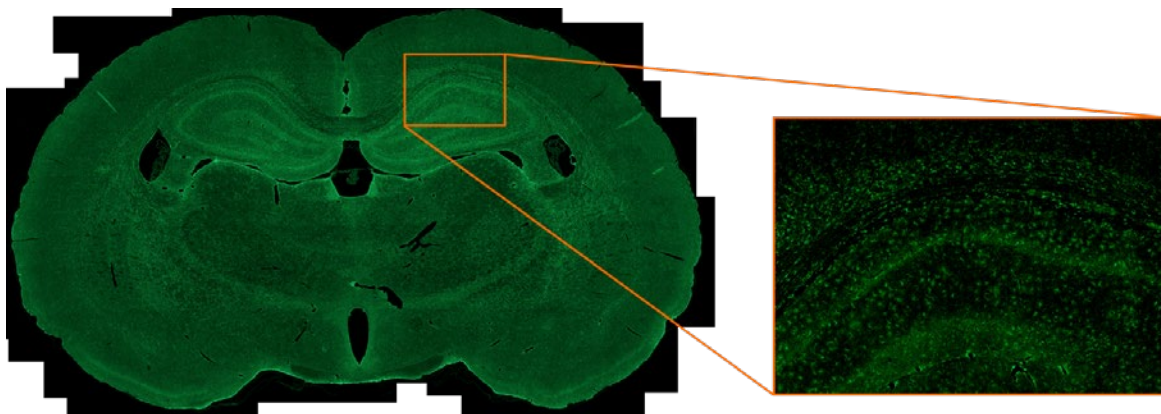

Flexible Upgrades

Since the DP75 camera uses USB 3.1 Gen2, it is compatible with most PCs for a simple, effective upgrade to your current system.



*Please see the system PC requirements in the specifications section.

DP75 Specifications

Item		Specifications
Camera type		Single-chip color camera (pixel shifting) Cooling system: Peltier device (active cooling)
Imaging sensor size		1.1-inch, 12.37-megapixel color CMOS image sensor, global shutter
Camera mount		C-mount
Effective image resolution		8192 × 6000 (pixel shifting), 4096 × 3000 (3CMOS mode), 4096 × 3000 (1 × 1), 3840 × 2160 (1 × 1) (by cropped), 2048 × 1500 (2 × 2), 2048 × 1500 (1 × 1), 1920 × 1080 (1 × 1), ROI
Sensitivity		1x/2x/4x/8x/16x/32x (ISO 100/200/400/800/1600/3200 equivalent)
A/D		12-bit
Metering modes	Mode	Auto / SFL-Auto / Manual
	Adjustment	±2.0 EV step: 1/3 EV
	Time	28 μs–120 s
Binning		2 × 2
White balance		Auto/One-touch/Manual/Area designation
Black balance		Auto/One-touch/Manual/Area designation
Live frame rate *1		4096 × 3000 (1 × 1): 22 fps, 2048 × 1500 (2 × 2): 22 fps, 2048 × 1500 (1 × 1): 44 fps, 1920 × 1080 (1 × 1): 60 fps
Still image transfer time		8192 × 6000 (pixel shifting): approx. 3 s, 4096 × 3000 (3CMOS Mode): approx. 2 s, 4096 × 3000 (1 × 1): approx. 1.2 s, 2048 × 1500 (2 × 2): approx. 1.0 s, 2048 × 1500 (1 × 1): approx. 0.4 s, 1920 × 1080 (1 × 1): approx. 0.4 s
Monochrome mode		Available (Standard/Custom)
Color space		sRGB, AdobeRGB*2
Linear mode		Available
IR cut filter		Switchable: In: 400 nm up to 650 nm Out: 400 nm up to 1000 nm
Manual panoramic imaging (instant MIA) *3*4		Available (supports fluorescence as well as brightfield)
Auto scene recognition mode*4		Available using an AI algorithm (supports: brightfield, fluorescence, phase contrast, differential interference contrast, and polarization)
Position navigator*4		Available
Control software		cellSens Entry / Standard / Dimension v. 4.2.1 or later DP2-TWAIN v. 10.5. or later
External trigger		Available (input/output)
Dimensions (W × D × H)	Camera interface cable	Approx. 2.7 m (8.9 ft)
	AC adapter	107 × 47 × 30 mm (4.2 × 1.9 × 1.2 in.)/Approx 0.3 kg (0.7 lb)

DP75 System Requirements

Item		Specifications
CPU		Intel Core i5, Intel Core i7, Intel Xeon, or equivalent of Intel CPU
RAM		8 GB or more (recommended 16 GB or more)
PC I/F		USB 3.1 Gen2 (TypeA) (a dedicated board is unnecessary)*5
OS		Windows 10 Pro (64-bit)
		Windows 11 Pro (64-bit)

*1 Frame rate may decrease depending on the condition of your PC, monitor resolution, and/or software.

*2 Monitor designed to meet Adobe RGB is required.

*3 Manual Process option license is required for cellSens Standard.

*4 Not available in the combination of cellSens Entry or DP2-TWAIN.

*5 Operatable with USB3.1 Gen1 (5 Gbps), but framerate is decreased.

System Diagram

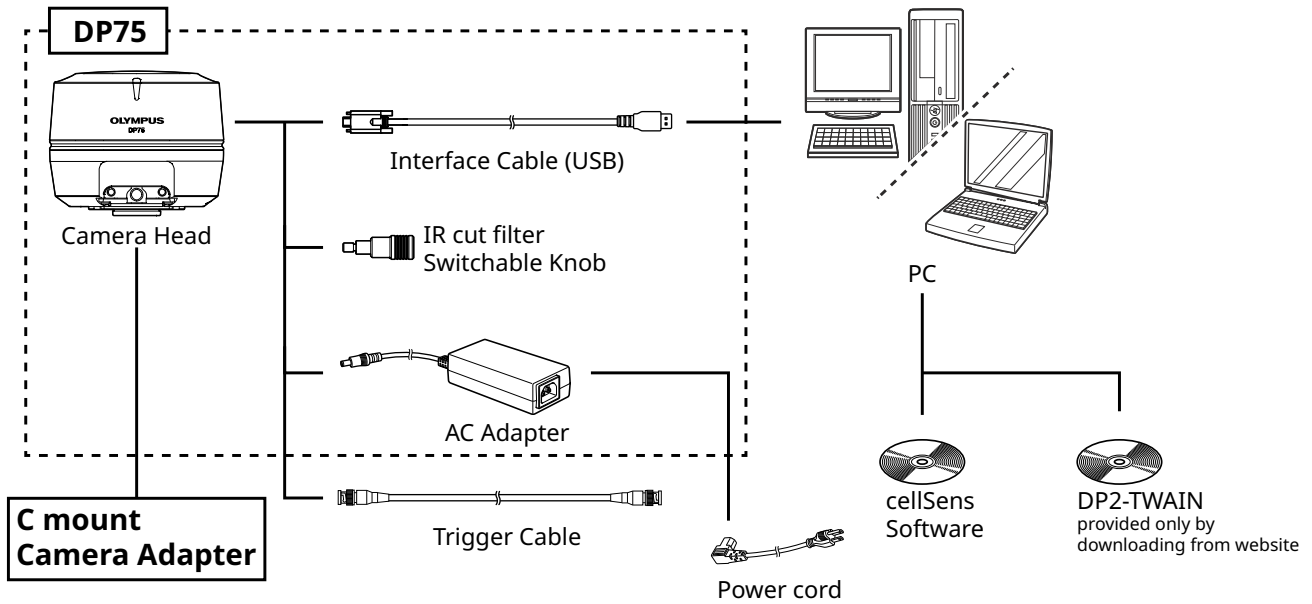

DP75 Dimensions

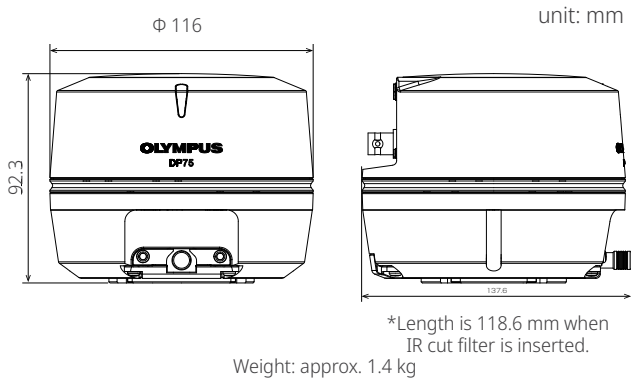

Cover image: Rat brain. DAPI, Alexa Fluor 488, Alexa Fluor 555, Alexa Fluor 750

- **EVIDENT CORPORATION is ISO14001 certified.**
For details on certification registration, visit <https://www.olympus-lifescience.com/en/support/iso/>
- **EVIDENT CORPORATION is ISO9001 certified.**
- All company and product names are registered trademarks and/or trademarks of their respective owners.
- Specifications and appearances are subject to change without any notice or obligation on the part of the manufacturer.
- Images on the PC monitors are simulated.

[EvidentScientific.com](https://www.evidentscientific.com)

EVIDENT

EVIDENT CORPORATION
Shinjuku Monolith, 2-3-1 Nishi-Shinjuku, Shinjuku-ku, Tokyo 163-0910, Japan

OLYMPUS