

SPECIFICATIONS
for
Diagnostic Ultrasound System
ARIETTA 850

MODEL: ALOKA ARIETTA 850

SPH-ARIETTA850-V60-E01

Printed in Japan, 2023-09

Basic Specifications

Scanning Method

- Electronic Convex
- Electronic Linear
- Electronic Phased Array Sector
- Electronic Radial

Operating Modes

- **B-mode**
- BiPlane-mode
- M-mode
- D: Spectral Doppler mode (**PW**, **CW**, **HPRF-PW**)
- Dual Gate Doppler mode
- **Color Flow mode**
- **Power Doppler** mode (Directional Power Doppler)
- eFLOW mode (Directional eFLOW)
- Cardiac 3D mode*
(3D Zoom, Active 3D, Wide Angle 3D)

* Option: SOP-ARIETTA850-129, EU-9183 or EU-9207, PEU-LISENDO880

Image Display Modes*¹

- B: gray-scale imaging
- Dual B
- Quad B
- M
- **B and M**
- D
- **B and D**
- B(Color Flow)
- B(Power Doppler)
- B(eFLOW)
- Dual B(Color Flow)
- Quad B(Color Flow)
- Dual B(Power Doppler)
- Quad B(Power Doppler)
- Dual B(eFLOW)
- Quad B(eFLOW)
- **M(Color Flow)**
- M(Power Doppler)
- M(eFLOW)
- **B(Color Flow) and M(Color Flow)**
- B(Power Doppler) and M(Power Doppler)
- B(eFLOW) and M(eFLOW)
- **B(Color Flow) and D**
- B(Color Flow) and Dual
- B(Power Doppler) and D
- B(Power Doppler) and Dual

- B(eFLOW) and D
- B(eFLOW) and Dual
- B(Color Flow) and D simultaneous real-time display (**Triplex mode**)
- B(Power Doppler) and D simultaneous real-time display (**Triplex mode**)
- B(eFLOW) and D simultaneous real-time display(**Triplex mode**)
- B and B(Color Flow) simultaneous real-time display (Dual Flow)
- B and B(Power Doppler) simultaneous real-time display (Dual CF)
- B and B(eFLOW) simultaneous real-time display(Dual Flow)
- Dynamic Slow-motion Display(Real-time image/Slow-motion image, side by side display)
- Real-time Biplane(Display real time image in 2 cross-sections in biplane probe.)
- **Panoramic View**
- **TDI(Tissue Doppler Imaging)**
- Intermittent trigger mode*²
- Monitor mode(Monitor image/CHI mode image, side by side)*²
- RT-3D(4D) mode*³
- Detective Flow Imaging(DFI)*⁴
- Request function: In multi-mode display, it is possible to select one mode for full screen display.
- Real-time Tissue Elastography*⁵
- 3D Zoom mode(Color)*⁶
- Active 3D mode(Color)*⁶
- Wide Angle 3D mode(Color)*⁶

*¹ Probe dependent.

*² Option: SOP-ARIETTA850-44

*³ Option: EU-9184, SOP-ARIETTA850-4

*⁴ Option: SOP-ARIETTA850-105

*⁵ Option: SOP-ARIETTA850-43

*⁶ Option: SOP-ARIETTA850-129, EU-9183 or EU-9207, PEU-LISENDO880

Beam former

- Transmission
CPWG(**Compound** Pulse Wave Generator)
Programmable waveform transmission
- Reception
Multi processing high-speed digital beam former
12-bit A/D converter(4096 gray levels)
A/D Sampling Frequency: 40 [MHz]
Parallel processing: Up to 20 directions

- Transmission/Reception method of Harmonics:
 - FmT: Filter-method Tissue **Harmonic Imaging**
THI mode image without reducing the frame rate.
 - WbT: Wide-band Tissue Harmonic Imaging
THI mode image with higher resolution than FmT.
 - HdT: High Definition Tissue Harmonic Imaging(HdTHI)
THI mode image with higher resolution than WbT.
- Reception frequency: 3.2-22.0 MHz*
 - *: 22.0 MHz can be achieved under below conditions.
 - Probe: SML44
 - Frequency: High
 - Frequency Information: Receive
- Tissue Adaptive Technology:
 - Sound speed adjustment: 26 steps
 - Automated sound speed adjustment
- Focusing
 - Transmission
Multi-stage transmission focus of up to 4 stages out of 16 stages (probe dependent)
 - Reception: PixelFocus, eFocusing

System Dynamic Range

320 dB

System Processing Channels

7,072,000 Channels

Frame rate

Max. 882 frames/sec*

* It is a measured value with the setting assuming the maximum value. This value may be exceeded depending on the conditions.

Volume rate(Mechanical 3D scanning)

Max. Up to 41 volumes/sec*

* Depends on probes and various settings

Imaging

B-mode

- Display Gray Scale: 256 levels
- Scanning area:
25 to 100%, Continuously variable
- Line Density: Up to 8 steps
- HI Frame Rate
Improve frame rate by Multi Parallel Processing
- Zoom:
 - HI zoom(real-time image):

- Minimum display of 5mm
- PAN zoom(real-time and frozen image):
Minimum display of 5mm
- Frequency selection:
 - Fundamental:
Max. 5 frequencies(probe dependent)
 - Tissue harmonic:
Max. 5 frequencies(probe dependent)
- Depth range selections:
0.75/1.0/1.5/2.0/2.5/3.0/3.5/4.0/4.5/5.0, 1 cm intervals from 5.0 to 24 cm, and 2 cm intervals from 24 cm to **40 cm**(probe dependent)
- Longitudinal and lateral inversion
- Rotation by 90 degrees(probe dependent)
- Gain
0 to 80 dB, 1 dB step, adjustable in real-time and frozen.
- Echo enhancement: 8 steps(Including OFF)
- Texture: 2 steps(Smooth/Sharp), not available in M-mode.
- Smooth/Enhance:
 - -8 to -1: Smoothing level
 - 0: OFF
 - 1 to 8: Edge enhancement level
- Persistence
8 steps(Including OFF), 2 types(Manual/Auto)
- Time Gain Control(TGC): Gain versus depth curve control
8 slide controls, TGC curve memory function
- TGC Enhancement: ON/OFF possible, working with CF
- Lateral Gain Control(LGC): Gain versus angle curve control.
8 sectors(Sector probes only)
- Dynamic range
40 to 90 dB, adjustable in real-time and frozen.
- Gray map: 10 types, adjustable in real-time and frozen.
- Auto Gain Control(AGC): 8 steps(Including OFF)
- Gamma Curve
4 types(Linear, Window, Parabolic, S-curve), control points(Rejection, Center, Saturation), changeable in real-time and frozen.
- **Compound**
Possible by selected linear and convex sector probes.
- Trapezoidal Scanning
Possible by selected linear probes
- Beam Steer
Possible by selected linear probes
- HI REZ: Image filter that maintains the edges of

structures while reducing speckle noise.

8steps, ON/OFF possible

- HI REZ PLUS: ON/OFF possible
- Border Clear Filter(BCF): Image filter that enhance the edges of structures.
ON/OFF possible, only available when HI REZ is ON
- Acoustic Noise Reduction(ANR): It reduces artifacts.
OFF+9 steps, 2 types(A-B)
- Near-field Noise Reduction(NNR): It reduces artifacts and noises in the heart chamber or blood vessels.
 - OFF+3 steps(Low, Mid, High), 5 types(A-E)
 - Carving Imaging: OFF+9 types(combination of NNR type(C, D, E) and levels(Low, Mid, High))
- Low Echo Reduction: Suppresses the hypoechoic areas.
0 to 70%, 2% step, adjustable in real-time and frozen
- Grayscale Enhancement: Sets the balance between low brightness and high brightness of grayscale.
OFF+3 steps(Low, Mid, High)
- Auto-optimizer: Gain, TGC, LGC, sound velocity
- Needle Emphasis: Improves the visibility of the puncture needle echo.
- Wide Scanning: Display image with a wide field of view.
- Panoramic View: Display a panoramic image by moving the probe in a wide range.

M-mode

- Sweep method: Moving bar
- Sweep speed
7 steps(40.0, 50.0, 66.7, 100, 133.3, 200, 300 mm/sec)
- Gain
B Gain \pm 30dB, working with B Gain, adjustable in real-time and frozen.
- Dynamic Range
40 to 90 dB, 1 dB step, adjustable in real-time and frozen.
- Auto Gain Control(AGC): 8 steps(Including OFF)
- Acoustic Noise Reduction(ANR): It reduces artifacts.
Working with B mode.
- Low Echo Reduction: Suppresses the hypoechoic areas.
0 to 70%, 2% step, adjustable in real-time and frozen.
- Grayscale Enhancement: Sets the balance between low brightness and high brightness of grayscale.
OFF+3 steps(Low, Mid, High)
- **Free Angular M(FAM)**: Displays an M mode image on any line of the B mode image.

Spectral Doppler Mode

- Display: Power spectrum
- Real-time Doppler Auto Trace
- Doppler methods:
 - PW(Pulsed Wave) Doppler
 - **HPRF(High Pulse Repetition Frequency)** PW Doppler
 - Dual Gate Doppler
 - **CW(Continuous Wave) Doppler***
 - TD(Tissue Doppler)-PW
- Reference **frequencies** (probe dependent):
Maximum 3 frequencies
 - PW: 1.5, 1.9, 2.0, 2.1, 2.5, 3.0, 3.3, 3.5, 3.8, 4.0, 4.4, 5.2, 6.0, 6.3 MHz
 - CW: 1.7, 1.8, 2.0, 2.1, 2.5, 3.0, 3.3, 3.8, 5.0 MHz
- Pulse repetition frequency
 - PW: 0.05 to 40 kHz
- Analysis rate
 - CW: 1.1 to 40 kHz
- Max. **velocity** range:
 - PW/HPRF: \pm 1.26 cm/sec to \pm 802.08 cm/sec
 - CW: \pm 25.07 cm/sec to \pm 1600 cm/sec
- Base line shift: Adjustable in real-time and frozen.
- Steerable CW: Possible with selected probes.
- Beam Steer
-30 to 30 degrees(probe dependent), 5 degrees step, possible with linear probes.
- Spectrum inversion
- Angle correction
0 to 80 degrees, adjustable in real-time and frozen.
Auto angle correction
- Sample Volume
Size: 0.5 to 20 mm(0.5 mm,1.0 mm step)
Display depth of the sample volume
- Wall filter: 12 steps, 1/16 of PRF is Max.
- Gain
0 to 60 dB, ON/OFF possible, adjustable in real-time and frozen.
- Low Echo Reduction: Suppresses the hypoechoic areas.
0 to 30%, 2% step
- Grayscale Enhancement: Sets the balance between low brightness and high brightness of grayscale.
OFF+3 levels(Low, Mid, High)
- Echo Enh.: OFF+2 levels(Low,High)
- Dop. Gamma: Changes the Doppler waveform contrast, and the level of gamma adjustment.
8 levels, adjustable in real-time and frozen.
- Auto Optimizer: Automatically adjusts image.
Gain, PRF, baseline, Angle Correction, position of

- sample volume
- Audio output: 2 channels
- * Option: EU-9184

Color Doppler Mode

- Flow area: 25 to 100%, 5% step
- Beam Steer
 - 30 to 30 degrees(probe dependent), 5 degrees step, possible with linear probes
- Line Density
 - 8 levels, adjustable independently with B mode.
- Gain: 128 levels
- Texture: 2 levels(Smooth/Sharp)
- Glossy Level: OFF+4 levels
- HI Frame Rate: Improve frame rate by Multi Parallel Processing.
- Auto Optimizer: Automatically adjusts image.
 - Gain, position of ROI
 - iVascular
 - Automatically identifies the long-axis blood vessels in an image, and sets the position of the flow area, the position and size of the sample volume, the blood flow direction, and the angle of the ultrasound beam(angle correction).

Color Flow(CF) mode

- Displays the orientation and velocity in color on the tomographic image, based on the Doppler signal obtained from the blood flow.
- Display patterns:
 - Velocity(derived from mean Doppler frequency shift),
 - Velocity + variance, Variance, Velocity + intensity,
 - Velocity + variance + intensity
 - Max. **velocity** range
 - ±0.63cm/sec to ±458.33cm/sec
 - Reference frequency(probe dependent)
 - 1.9, 2.0, 2.1, 2.5, 3.2, 3.3, 3.5, 4.0, 4.4, 5.2, 6.0, 6.3 MHz
 - Pulse repetition frequency: 0.03 to 19.8 kHz
 - Gradation:
 - Velocity: ±127 levels(red and blue)
 - Variance: 64 levels(green)
 - Invert Color Map
 - Smoothing: 5 steps, adjustable in real-time and frozen.
 - Persistence Level: 8 steps(Including OFF)
 - Wall Filter: 6 steps
 - Wall Motion Reduction(WMR)
 - OFF + 3 steps(Low, Middle, High), 2 methods
 - Packet Size: 3 levels(Large, Middle, Small)

- Baseline Shift: Up to double velocity(±64 steps)
- Color Map: 15 kinds
- TGC Enhancement
 - ON/OFF possible, working with B mode
- Display superimposed color image
 - Accumu. Imaging: ON/OFF possible, in real-time.
 - Capture Imaging: ON/OFF possible, in frozen.

Power Doppler(PD) mode

- Displays color on the image according to the intensity of the color Doppler signal. It is sensitive to slow blood flows.
- Display patterns: PD, Directional PD
 - Gradation: 256 levels
 - Color Map: 15 kinds
 - Non-display of B/W image: Possible in ROI
 - Smoothing: 5 steps, adjustable in real-time and frozen.
 - Wall Filter: 6 steps
 - Wall Motion Reduction(WMR)
 - OFF + 3 steps(Low, Middle, High), 2 methods

High Resolution Power Doppler(eFLOW) mode

- Displays in the Power Doppler mode in high-resolution.
- Display patterns: eFLOW, Directional eFLOW
 - Pulse repetition **frequency**: 0.03 to 19.8 kHz
 - Gradation: 256 levels(±127 levels for directional)
 - Color Map: 15 kinds
 - Smoothing: 5 steps, adjustable in real-time and frozen.
 - Wall Filter: 6 steps
 - Wall Motion Reduction(WMR)
 - OFF + 3 steps(Low, Middle, High), 2 methods

Cine Memory

- Cine search and loop display (in B mode):
 - ECG time phase display is possible
- Capacity
 - B mode: Max. 63,500 frames.
 - M/D mode: Max. Approx. 900 seconds.

Physiological Signal Display

- Displayed information:
 - ECG, PCG*¹, Pulse*², Breathing waveform
- ECG synchronized display: Available for one phase
- Detect regular pulse from arrhythmia(RRp/RRpp)
 - Automated jumping to most optimized R-R Phase
 - Reducing Filter for Tachy or Bradycardia
 - Display value for each R-R interval time
- Display position:
 - Continuously variable(both in B and M modes)
- Bar graph display for breathing waveform

-
- 3 type electrocardiogram(I, II, III)
 - Automated detection end diastole and end systole phase.
 - Automated split as end diastole(left) and end systole(right)

*1 Option: MA-300(Not available in EU)

*2 Option: TY-307A(Not available in EU)

Tissue Doppler Imaging(TDI)

- Switching Color Doppler and Tissue Doppler during exam is possible.

Dual Gate Doppler

This is a function which displays Doppler Spectrums of two different sample points simultaneously.

- Supported combinations are PW/PW, TDI/TDI, and PW/TDI*.
- Automated sample gate setting for each gate.

*: It is possible to measure E/e' immediately(approx. 5 seconds) by recognition of imaging view and placement of sample volumes automatically in addition to detect stable heart beats with R-R Navigation.

Automated Intima-Media Thickness(IMT) Measurement

It is possible to automatically extract max, min, average and SD of IMT by simply setting ROI(region of interest) on a long-axis view of the vessel.

- The thicknesses at 3 points, i.e., the point at max IMT, and the points at 1cm on the right and left of the max IMT, can be automatically detected and averaged.

Protocol Assistant

This function ensures that all measurements and image saving are performed without fail by carrying out examinations with the protocol that has been registered in advance.

- Protocol registration: 128 kinds can be registered.
- Suspend protocol function
- Create and edit protocol on the system
- Register and edit reference image
- Import/Export protocol

Manual

It is applicable to browse instruction manual on this system.

- On-board operation manual

Data Management

Image data

- Format
 - Multiple-frame(moving) image
 - DICOM(Raw, MJPEG)
 - PC Format(WMV, AVI, MP4)
 - Single-frame(still) image
 - DICOM(Non-compressed, RLE, RGB(Plane/Pixel), JPEG)
 - PC Format(Tiff, Bmp, JPEG)
- Image acquisition mode
 - Real-time multi-frame image acquisition
Raw, Image, RAW and Image at the same time
 - Post ECG: Max. 10 cardiac cycles(R-R)
 - Pre ECG: Max. 10 cardiac cycles(R-R)
 - Post Time: Max. 90 seconds
 - Pre Time: Max. 16 seconds
 - Manual:
 - Raw data: Max. 150 seconds
 - Image data: Max. 180 seconds
 - Cine loop high-speed data transfer(Raw, Image)
It is possible to selectively store data of arbitrary section in the Cine Memory.
 - Simultaneous output to multiple media
It is possible to output still image data to multiple of storage media include network and printers at the touch of a button.
- Image data management tool
 - Image viewer
 - Compatible with DICOM and PC-format images
 - Simultaneous display of stored and real-time images is possible(Compare mode)
 - Thumbnail display of stored images(1-36 images)
 - Check mark is put on a transferred image
 - Image zoom, rotation, inversion
 - Protect stored images
 - 1:1 replay(main unit HDD or DICOM storage data)
 - DVD-RAM
 - CD-R
 - USB memory
 - USB HDD
 - Re-storing to media, transfer
 - Adjustment is possible on the reconstructed Raw-data image (Gain, Dynamic Range, Gamma Curve, and Color Map in CF mode)

Measurement data

It is possible to store measurement data in the main unit hard disk

Patient data

- Displayed information*
 - Patient information
ID(up to 64 characters), Name(up to 64 characters, including middle name), Birthdate, Sex, Age, Height, Weight, Occupation
 - Study information
Procedure ID, Accession, Study ID, Study Description, Referring physician, Reporting Phys, Sonographer

*: Conforms to DICOM 3.0 standard

Data storage

- Main unit hard disk
 - Capacity: Approx. 1TB
- USB memory
- USB HDD
- CD-R
- DVD-RAM
- DVD-R
- Network interface(DICOM format)
10 BASE/T or 100 BASE/TX, automatically switched

DICOM network communication

- Conformity to DICOM service class:
 - Ultrasound image storage SCU
 - Ultrasound multi-image storage SCU
 - Storage media FSC/FSR
 - Print management SCU
 - Modality worklist management SCU
 - Modality performed procedure step(MPPS) SCU
(For details, please refer to the DICOM Conformance Statement issued by FUJIFILM Healthcare Corporation.)
- Storage
Possible to store patient information directly to DICOM file server.
- Print
Possible to printout images with DICOM compatible printer directly.
- Work list management
Retrieval of patient and reservation information from hospital information system(HIS)
NOTE: The HIS needs to be compatible with DICOM standard

supplement 10. The HIS network and the DICOM network need to be linked.

- Router setting
- Compatible with SR(Structured Report) for OB, cardiology, vascular and abdominal measurements*¹
- Query/Retrieve*²
- Compatible with ED(Evidence Documents)
- Profile
- Integrated Healthcare Enterprise(IHE)
 - SWF(Scheduled Workflow)
 - PDI(Portable Data for Imaging)
 - ED(Evidence Documents in Radiology/Cardiology domain)
 - Echocardiography Workflow
 - CT(Consistent Time)

*1 Option: SOP-ARIETTA850-21

*2 Option: SOP-ARIETTA850-59

Security measures

- User authentication function is available.
 - 3 Types of user authority can be set.
 - It is possible to set whether password is necessary or not at the start of operation.
- Audit logs
 - Accesses related to user management and patient data are recorded as audit log data.
 - Handling of these logs is limited to users with Level 1 access.

Teaching file

Possible to create teaching file.

Measurements and Analysis

Basic measurements

B mode

- Distance measurement: Distance, Dist-trace
- Area and Circumference measurement: Area/Circum
- Volume measurement: Volume1, Volume2
- Angle measurement: Angle
- Histogram measurement: Histogram
- Measurement of Congenital Dislocation of the Hip Joint:
- Hip J Angle
- General purpose index measurement: B.Index

M mode

- Distance measurement: M.Length
- Time measurement: Time
- Heart rate measurement: Heart Rate
- Velocity measurement: M.VEL.
- General purpose index measurement: M.Index

D mode

- Time measurement: Time
- Heart rate measurement: Heart Rate
- Blood flow velocity measurement: D.VEL1, D.VEL2
- Acceleration (deceleration) measurement: ACCEL
- Resistance index measurement: RI
- Pressure half-time measurement: P1/2T
- Dop.Caliper measurement: D.Caliper1, D.Caliper2
- Measurement of mean velocity and mean pressure gradient*1: Mean VEL.
- Pulsatility index measurement*1: PI
- Stenosis flow measurement*1: Steno Flow
- Regurgitant flow measurement*1: Regurg Flow
- Dop.Trace measurement*1: D.Trace1, D.Trace2
- General purpose index measurement*1: D.Index

B/D mode

- Blood flow volume measurement *1: F.Volume, SV/CO

CF mode

- Blood flow volume measurement: Flow Profile*2

*1: Auto trace is possible.

*2 Option: SOP-ARIETTA850-7

Application measurements

Abdominal measurements

B mode

- Gallbladder measurement: Gallbladder
- Gallbladder wall thickness measurement: GB Wall-T

- Common bile duct measurement: CBD
- Liver measurement: Liver
- Pancreas measurement: Pancreas
- Pancreatic duct measurement: P-Duct
- Renal measurement: Renal Volume
- Spleen measurement: Spleen
- Space-occupying lesion measurement: SOL
- Blood vessel diameter measurement
Aorta Diam, PV Diam
- Stenosis percentage measurement
%STENO-Diam, %STENO-Area

D mode

- Artery measurement
A-Ao, CA, CHA, SA, SMA, IMA, CIA, HA, Prandial SMA
- Renal artery measurement*
Renal-A, RA hilum, Seg.A Upp, Seg.A Mid, Seg.A Low
- Portal vein measurement: Main PV, Rt.PV, Lt.PV
- Shunt blood vessel measurement
Pre Shunt PV, Prox Shunt, Mid Shunt, Distal Shunt

B/D mode

- Blood flow volume measurement
FV(Artery) Abdom, FV(Vein) Abdom

*: Auto trace is possible.

Cardiology measurements

B mode

- L Cardiology measurements
M.Simpson*1, GLS(3P)*2, Area-Length*1, Pombo*2, Teichholz*2, Gibson*2, Bullet, Simpson, BP-Ellipse, EyeballEF*3
- Valve area measurement: AVA, MVA
- Aortic valve measurement: AV(2D)
- Pulmonary valve annulus diameter measurement
PV Annulus
- TAVI/TAVR measurement: TAVI/TAVR
- Right ventricular diameter measurement:
RV Dimension, RV(2D)
- Left atrial diameter/aortic diameter measurement
LA/AO
- Myocardial wall thickness ratio measurement: Ratio
- Left ventricular myocardial mass measurement
LV Mass(AL), LV Mass T-E, LV Mass Pedi, LV Mass Pedi Simpson*2
- Inferior vena cava diameter measurement: IVC
- Left atrial/right ventricle volume measurement*4
LA Vol., RA Vol.

- Right ventricular function measurement*2: FAC

M mode

- Left ventricular function measurement*5
Pombo, Teichholz, Gibson
- Mitral valve measurement: Mitral Valve, MV(M)
- Tricuspid valve measurement: Tricuspid Valve
- Pulmonary valve measurement: Pulmonary Valve
- Left atrial diameter/aortic diameter measurement*6
LA/AO
- Inferior vena cava diameter measurement: IVC
- Asynchrony measurement: IntraV.Async.
- Measurement of tricuspid annular plane systolic excursion(TAPSE):
TAPSE
- Right ventricular measurement: RV(M)

D mode

- Left ventricular ejection flow measurement*7
LVOT Flow, LVOT
- Aortic stenosis flow measurement*7: AS Flow, AV
- Aortic valve regurgitation flow measurement*7
AR Flow, AR
- Right ventricular ejection flow measurement*7
RVOT Flow
- Pulmonary stenosis flow measurement*7
PS Flow, PVA, PV, PA
- Pulmonary valve regurgitant flow measurement*7
PR Flow, PR
- Left ventricular inflow measurement*7*8
Trans M Flow, MV, MV Valsalva
- Mitral annulus diameter measurement: MV Annulus
- Mitral stenosis flow measurement*7: MS Flow
- Mitral regurgitant flow measurement*7: MR Flow
- Tricuspid annulus diameter measurement: TV Annulus
- Tricuspid inflow measurement: TV, TV Valsalva
- Tricuspid stenosis flow measurement*7: TS Flow
- Tricuspid valve regurgitant flow measurement*7
TR Flow, TVA(VTI), TVA(pV)
- Pulmonary vein flow measurement: PV Flow
- PISA measurement
MR Vol. PISA, AR Vol. PISA, TR Vol. PISA, PR Vol. PISA
- TDI PW measurement*7*8
TDI PW MW, TDI PW1, TDI PW2, M Annulus(m), M Annulus(l), M Annulus(s), T Annulus(s), T Annulus(l)
- MPI measurement: LV MPI, RV MPI, RV MPI(Tissue)
- Aorta measurement*2
Ascending Ao Doppler, Descending Ao Doppler,

Transverse Ao Doppler, Abdominal Ao Doppler

- Blood Flow Measurement of a Defect Hole for Congenital Heart Disease*2: ASD, VSD, PDA, PFO
- Coronary measurement*7
prox LAD(Rest), prox LAD(Peak), distal LAD(Rest), distal LAD(Peak), RCA(Rest), RCA(Peak), LCX(Rest), LCX(Peak), Graft(Rest), Graft(Peak),
Coronary1,2,3(Rest)(Peak), Coronary Stenosis
- Asynchrony measurement
AV Async., InterV.Async., TDI PW Time to Onset, TDI PW Time to Peak

CF mode

- M TDI measurement
M TDI mFS, M TDI WT(LVPW), M TDI MT(IVS)
- *1: Auto or Full Auto measurement is possible.(Option: SOP-ARIETTA850-74 is necessary for Full Auto measurement.)
- *2: Auto measurement is possible.(Option: SOP-ARIETTA850-74 is necessary for Auto measurement.)
- *3 Option: SOP-ARIETTA850-58, PEU-LISENDO880
- *4: Auto or Full Auto measurement is possible.(Option: SOP-ARIETTA850-74 is necessary when Auto or Full Auto measurement.)
- *5: Caliper Mark Auto Shift is possible.
- *6: Auto measurement is possible.(Option: SOP-ARIETTA850-74 and PEU-LISENDO880 is necessary when Auto measurement.)
- *7: Auto trace is possible.
- *8: Option: PEU-LISENDO880 is necessary for Doppler Trace method.

Vascular measurements

B mode

- Carotid Artery:
 - Stenosis measurement
Carotid %STENO-D, Carotid %STENO-A
 - mean-IMT measurement: mean-IMT, CmeanIMT*1
 - Max-IMT measurement
max-IMT, IMT-Cmax, IMT-Imax, IMT-Bmax
 - IMT Automatic measurement:
CCA_IMT, ICA_IMT, ECA_IMT, BIF_IMT
 - IMT-C10 measurement: IMT-C10, IMT-C10 Auto*1
- Upper Ext Artery:
 - Stenosis measurement
Upper %STENO-D, Upper %STENO-A
- Lower Ext Artery:
 - Stenosis measurement
Lower %STENO-D, Lower %STENO-A

D mode

- Carotid artery blood flow measurement
CCA proximal, CCA mid, CCA distal, ICA, ECA, BIFUR, VERT
- Upper extremity artery blood flow measurement
ScA, AA, BA, DBA, BasA, RA, UA, SPA
- Lower extremity artery blood flow measurement
CIA, EIA, IIA, CFA, DFA, SFA, PopA, PerA, ATA, PTA, DPA
- Transit time of vessel flow(TVF) measurement*²
TVF_CFA, TVF_POP, TVF_ATA, TVF_PTA, TVF_PA
- Upper extremity venous blood flow measurement
IJV, ScV, CV, AV, BV, DBV, BasV, RV, UV
- Lower extremity venous blood flow measurement
CIV, EIV, IIV, CFV, DFV, SFV, GSV, PopV, PerV, LSV, ATV, PTV
- Transcranial artery blood flow measurement
ACA, MCA, PCA, BA, VA, TICA, ACoA, PCoA

*1: IMT Auto measurement is possible.

*2 Option: SOP-ARIETTA850-47, PEU-LISENDO880

Small parts measurements

B mode

- Lesion measurement(for breast use): Lesion(Breast)
- Aspect ratio measurement: D/W ratio
- Papilla-tumor distance measurement: NT dist
- Thyroid gland volume measurement: Thyroid Volume
- Thyroid isthmus thickness measurement
Isthmus Thickness

D mode

- Artery measurement(for mammary blood flow)
- Artery measurement(for thyroid blood flow)

Obstetric measurements

B mode

- Gestational age measurement*¹: GA
- Fetal weight measurement: FW
- Ratio measurement: Fetus Ratio
- Amniotic fluid index measurement
AFI*², AF Pocket, AFV, MVP
- Cardiothoracic ratio measurement: CTAR, CTR
- Cervical length measurement: Cervix
- Nuchal translucency measurement: Auto NT*¹*³
- Automatic measurement of fetal heart rate*¹*⁴
Auto FHR, Auto FHR+*⁵
- Automatic measurement of fetal fractional shortening*¹*⁶: Auto FS

M mode

- Left ventricular function measurement: LV Function
- Fetal heart rate measurement: FHR, PreHR, PstHR

D mode

- Blood flow measurement
Umbilical Artery, MCA, Uterine Artery, Descending Aorta, Renal Artery
- Left(right) ventricular ejection flow measurement:
LVOT Flow, RVOT Flow
- Preload index measurement: PLI
- Ductus venosus measurement: Ductus Venosus
- Fetal heart rate measurement: FHR, PreHR, PstHR

Others

- Supports multiple pregnancy examination

*1 Auto measurement is possible.

*2 Caliper Mark Auto Shift is possible.

*3 Option: SOP-ARIETTA850-42

*4 Option: SOP-ARIETTA850-72

*5: in real time

*6 Option: SOP-ARIETTA850-71

Gynecology measurements

B mode

- Uterus measurement: Uterus
- Endometrial thickness measurement: Endom-T
- Cervix measurement: Cervix
- Ovarian measurement: Ovary
- Follicular measurement: Follicles
- Follicle volume measurement: Follicles Volume
- Bladder measurement: Bladder Volume

D mode

- Uterine artery measurement: Uterine Artery
- Ovarian artery measurement: Ovarian Artery

Urological measurements

B mode

- Prostate measurement: PSA Volume, PRS Slice Vol.
- Seminal vesicle measurement: Seminal Vesicles
- Bladder measurement: Bladder Volume
- Testicular measurement: Testis Volume
- Renal measurement: Renal Volume
- Cortical measurement: Cortex Thickness
- Adrenal measurement: Adrenal

D mode

- Arterial blood flow measurement: Renal Artery

Report functions

- Measurement report
 - Abdominal measurement report
 - Cardiac function measurement report
 - Vascular measurement report
 - Small parts measurement report
 - Obstetric measurement report
 - Gynecology measurement report
 - Urological measurement report
- Recall past measurement reports.
- Plot examination data history on the report.
- Direct printout of each report with an optional PC printer.
- Output of measurement values in CSV file is possible.

Others

- Playback measurement
- Assign measuring functions to the alphabet keys on the keyboard.
- User's Calculation: Combine basic measurement functions such as distance, area and flow velocity to create index calculation formulas for measurement packages.
 - It is possible to create measurement packages that contain a total of 30 calculations per application.
- Reserved Word: Measurement parameter names for application measurements, or user-registered measurement names that can be used in User's Calculation.
 - 60 reserved words can be registered for each application.
- Font size of measurement result
 - 3 kinds(x1, x1.2, x1.4)

Optional Functions

PC printer

It is possible to printout Abdomen, cardiology, vascular, small parts, OB/GYN, and urology report screens including ultrasound images directly with an external PC printer.

Cardiac 3D(4D)*

Cardiac 3D(4D) function provides the capability to display Cardiology 3D image and to display dual image(reference image and biplane image) simultaneously by using TTE 2D array probe.

- Scanning rate: Up to 999 volumes/sec
- Biplane Mode(Color)
- 3D Zoom Mode(Color)
- Active 3D Mode(Color)
- Wide Angle 3D Mode(Color)
- Live 1,2,3,4,5,6 beat 3D volume imaging
- Live 1,2,3,4,5,6,7 beat 3D color volume imaging
- It is possible to display 3 arbitrary sections simultaneously.
- MPR(Multi-planar Reconstruction)
- Auto Rotation
- 2 click cropping operation
- 3D Cropping
- Display Layout(Single, Dual, Quad, MSI)
- Multi slice Image
- Function to change 3D Imaging Parameter
- Change MPR View to operate by drag
- Density(Both Lateral and Elevation)
- Performance mode(Function to control the frame rate and volume rate to adjust the temperature at the probe tip.)
- Change Plane Angle to observe arbitrary cross-section.

* Option: SOP-ARIETTA850-129, EU-9183 or EU-9207, PEU-LISENDO880

iEF*

iEF calculates Biplane EF with full automated ED/ES frame detecting and full automated A2C and A4C contour tracing of biplane images acquired from a transthoracic 2D matrix probe.

* Option: SOP-ARIETTA850-120, SOP-ARIETTA850-74, SOP-ARIETTA850-129, EU-9183 or EU-9207, PEU-LISENDO880

4D LV-Analysis*

Additional features to 4D LV-Function

- Polar plot with parametric display for all parameters.
- Dynamic(amplitude) and static(time to peak) parametric

display for all parameters.

- Global LV twist and LV torsion calculation
- Automated workflow allows analysis can be started without user interaction.
- Displacement and strain analysis
 - Longitudinal, circumferential and radial component analysis
 - Principal tangential strain and 3D displacement analysis
 - Segmental peak, time to peak and global average values in result table
 - Segmental parameter over time chart display
- Rotation and twist analysis
 - Twist, Rotation Base, Rotation Apex
 - Segmental parameter over time chart display

* Option: SOP-ARIETTA850-112

This option is manufactured by TOMTEC Imaging System GmbH

4D RV-Function*

- Semi-Automated quantification of the Right Ventricle
 - Fast and easy Workflow
 - Automatic contour proposal - no laborious contour drawing
 - RV surface model
- 4D Review and Analysis
 - Real-time interactive 4D model(Beutel) display of ventricle
 - Display of 2D ultrasound slices(SAX and LAX) with Beutel contours as overlay
 - Graph displays for global volumes over time
 - Display of result window with derived parameters
- Measurements
 - Global volumes over time
 - Calculation of EDV, ESV, EF, SV
 - Right ventricular longitudinal strain(RVLS)
 - free wall
 - septum
 - Additional 2D measurements
 - TAPSE
 - FAC
 - RVDd base(RVD1)
 - RVDd mid(RVD2)
 - RVLd(RVD3)

* Option: SOP-ARIETTA850-113

This option is manufactured by TOMTEC Imaging System GmbH

4D MV-Assessment*

- Semi-Automated Annulus and Leaflet Detection

- Fast and easy Workflow
- Semi automatic annulus detection
- Automatic and dynamic MV model generation via object segmentation
- Automatic measurements for annulus, leaflets and coaptation
- Morphological and functional analysis views
- Analysis screen for 4D presentation of tissue and annular structures
- Transparency rendering to display all objects within tissue
- Definition and display of surgical and ventricular view orientations
- Display of B/W tissue and Doppler color information in all views
- Adjustable cut plane(D'Art)
- Color texture on leaflet models that represents their topology
- 4D Reconstruction Mode
 - Real-time rendering
 - Interactive 4D cube for data presentation and manipulation
 - 4D rendering of B/W tissue and color Doppler data
 - 3D visualization of automatic measurements
 - Hybrid 4D display of measurements and grayscale data
 - Interactive display settings for optimum display
 - Separate settings for threshold and transparency
 - Generic manual measurements
- Further general features
 - On-screen help
 - Planimetry layout for individual MPR adjustment
 - Carpentier segmentation labels on leaflet surface
- Measurements
 - Manual measurements such as distance, angle, curve and area
 - Static and dynamic annular measurements
 - Static and dynamic leaflet measurements
 - Static and dynamic coaptation measurements

* Option: SOP-ARIETTA850-114

This option is manufactured by TOMTEC Imaging System GmbH

RT-3D(4D)*1

- Method for acquiring volume data
 - 4D(real-time 3D): Captures volume data in a continuous B mode scan.
 - HI Definition 3D: Captures volume data in B mode.
 - Color 3D: Captures volume data in color Doppler

- mode.
- Spatio-Temporal Image Correlation(STIC)*2: Captures volume data in B mode or Color Doppler mode via a slow scan.
- Rendering Mode
 - Surface Sharp: Displays images that mix Surface(3D images with a smooth texture) and Sharp(3D images with a detailed texture) effects.
 - Surface MIP: Displays a mixed image composed of a surface image and MIP(maximum intensity projection: A 3D image at its highest echo intensity as seen from the viewpoint) image.
 - Surface X-ray: Displays a mixed image composed of a surface image and an X-ray(a 3D image averaged echo data seen from the viewpoint) image.
 - 4Dshading: Displays realistic 3D images with light and shadow that look like endoscopic images.
 - 4Dshading Flow: Displays realistic color Doppler 3D images with shadows, similar to optical images.
 - 4Dtranslucence: Displays 3D images in which the surface contour of the target has been enhanced.
- 3D Image Display Mode
 - 3D/4D: Displays cross-sectional and 3D images.
 - Free Axis of MPR(FMPR): Standard reference points can be moved, and the cross-sectional image displayed.
 - Multi Slice Imaging(MSI): Displays multiple cross-sections reconstructed from volume data.
 - Volume Slice Imaging(VSI): Displays 3D images of volume data of arbitrary thickness at a specific axis.
 - Curved MPR(CMPR): Displays cross sections on an arbitrary curve or straight line from the volume data.
- Measurements
 - Cross-sectional images: Distance, circumference, and area, etc. can be measured in the same way as with general B mode images. (except for STIC)
 - 3D Image: Measurements are possible in CMPR mode(distance, circumference) and VSI mode(distance).
- Auto Clipper: This function makes automatic adjustments to achieve an appropriate Clipper configuration to display a fetal in 3D image.
- 3D image quality adjustment: Lower Threshold, 3D HI REZ, Inversion Mode

*1 Option: EU-9184, SOP-ARIETTA850-4

*2 Option: SOP-ARIETTA850-41

Real-time Tissue Elastography*¹

It is a function to visualize the stiffness of a tissue in real-time. The strain generated in a tissue on applying pressure is represented by colors.

(It is available to change Elastography color map)

- Elasto mode
 - Overlapping display of Elastography on B-mode image.
- Dual Elasto mode
 - Dual image display of Elasto mode, possible to select different color map on each side.
- Real-time biplane
 - Elasto mode overlapping display of Elastography on B-mode image of either cross-section, in the function to display B-mode image with the one of different cross-section simultaneously.
- Strain Ratio measurement
 - Calculation of ratio of strain between arbitrary 2 regions.
- Assist Strain Ratio
 - Clicking center of the tumor automatically sets the measurement ROI to the tumor and the fatty layer (the mammary gland region and lesion are targeted).
- Strain Graph
 - The time variation of distorted average value is displayed on a graph in real time.
- Auto Select Frame
 - The frame under stable pressure is chosen automatically.
- Strain Histogram Measurement*²
 - Displays a histogram which shows the values of relative strain within an ROI and calculates the quantitative characteristics of the elasticity image and Liver Fibrosis Index.
- Compatible to RAW data
- Guide of displacement direction
 - Display the direction of displacement of the liver caused by the heart beat in real time.
- HI Strain
 - Performs the strain calculations based on multiple frames, and displays the most stable elasticity image.

*1 Option: SOP-ARIETTA850-43

*2 Option: SOP-ARIETTA850-60

Shear Wave Measurement*¹

It is a function for measuring shear wave propagation velocity(V_s), interquartile range of the V_s group(IQR), V_s effective rate(V_sN) and elastic modulus(E). The

propagation velocity of shear waves varies with tissue hardness.

- Shear Wave Measurement(SWM) mode
 - Measures the propagation velocity of shear waves in the target region.
- ROI setting function
 - A trackball can be used to change the position of the ROI you select to measure.
- Automatic recording of still images
 - The instrument can be set up to automatically send results after measurements.
- Integration with measurement functions
 - Measurement data is saved for each selected measurement. You can modify a measurement during an examination.
- Data saved to CSV files
 - Measurement data is saved in a CSV file.
- Attenuation measurement(iATT)*²
 - Simultaneously with the measurement of V_s , the ultrasound attenuation(ATT) is measured near the center of the ROI.
- Combi-Elasto is possible.

*1 Option: SOP-ARIETTA850-151

*2: It is only available with C251 and C252 probe.

Shear Wave Elastography*

It is a function for measuring the propagation velocity of shear waves and the stiffness, and creating images of the 2D distribution of propagation velocity. The propagation velocity of shear waves varies according to tissue hardness.

- Shear Wave Elastography(SWE) mode
 - You can superimpose shear wave propagation velocities in color on B mode images. The color SWE image appears inside the SWE ROI.
- ROI setting function
 - This function lets you use the trackball to adjust the position of the measurement ROI.
- SWE measurement
 - You can measure the propagation velocity of shear waves within a single or multiple arbitrary regions. Measurement starts when the image is frozen.

* Option: SOP-ARIETTA850-151

Combi-Elasto*

The Shear Wave Measurement screen and the Real-time Tissue Elastography screen are displayed at the same time in the dual-screen view. While viewing an elasticity

image, you can perform shear wave measurement to measure the velocity, hardness, and attenuation value of shear waves.

* Option: SOP-ARIETTA850-43, SOP-ARIETTA850-60, SOP-ARIETTA850-151

Automated NT Measurement*

It is possible to automatically extract the nuchal translucency(NT) thickness by simply setting ROI(region of interest). In addition, thicknesses at max NT, Mean NT can be automatically calculated.

* Option: SOP-ARIETTA850-42

Automated FHR Measurement*

Set measurement ROI on fetal heart plane in B mode image and measures heart rate automatically.

* Option: SOP-ARIETTA850-72.

Automated FS Measurement*

It is Possible to automatically extract the fetus left ventricle inside diameter shortening rate(FS).

* Option: SOP-ARIETTA850-71

Real-time Virtual Sonography*¹

This function is able to synchronize the volume data which was previously acquired by CT, MRI, PET, or US and in real-time US image.

The magnetic position sensor is installed on the probe to determine the position and angle of the probe.

As a result, the display of cross sections that match ultrasound images is enabled, allowing you to use the cross sections as a reference for your ultrasound diagnosis.

The same section of ultrasound image and CT/MR/PET image or US volume data is displayed as real time by acquiring the position information on the probe from a magnetic sensor and reconstructing MPR(Multi Planer Reconstruction) image from CT/MR/PET image and US volume data.

In various diagnosis areas(liver, breast and prostate) examination is possible as it supports convex type, linear type, intracavitary probe.

Moreover, it can use together with Real-time Tissue Elastography.

- Monitor Display:
 - Dual: Virtual / US
 - Quad: Virtual / US / Virtual / Virtual
 - Overlay: Virtual + US

- Magnetic field quality display
- 3D body mark display: ON/OFF
- 3D body mark size: 3 kinds
- Marking function
- Multi-volume function
 - Max. 4 CT/MR/PET/US images for retrieving, saving and the display switching
- US-US RVS function
 - US volume data generated beforehand can be displayed as Virtual image in the same to US real-time image section.
- Last registration
 - It is possible to return just before the condition of registration.
- Reset function
 - It is possible to return initial condition of registration.
- Built-in magnetic sensor*²
- Displaying fused virtual images*³
 - RVS can fuse a color display image to a black-and-white base image for playback. Combinations of the fusible base image and color display image are shown in the table below.

	Color display image		
	Parts image of the SYNAPSE 3D	MRI	PET
CT base image	Yes	-	Yes
MRI base image	-	Yes	-

- 3D Sim-Navigator*⁴
 - 3D Sim-Navigator is an auxiliary function provided by the Real-time Virtual Sonography(RVS) software.
 - Displays the puncture guideline on virtual images
 - Navigator view(3-screen)
 - Displays C-plane image
 - Registration of needle marks
 - Displays distance between multiple needle marks
- E-field Simulator *⁵
 - A color map superimposed on the CT image simulates the distribution of electric current from the given location of the multiple electrodes.
- Needle Tracking*⁶
 - Tracks and displays the needle tip location in real time during RFA procedures.
- Body Motion Tracking*⁷
 - The omniTRAX Active Patient Tracker (manufactured by CIVCO) provides automatic image registration of fused images using real time ultrasound with previously acquired CT; with the synchronized status adjusted when small patient movements occur.

1 Option: EU-9185, EZU-RVF1B, PM-AR850-H004, SOP-ARIETTA850-62

*2 Option: PM-AR850-H006(Probe dependent)

*3 Option: SOP-ARIETTA850-97

*4 Option: SOP-ARIETTA850-75

*5 Option: SOP-ARIETTA850-96

*6 Option: SOP-ARIETTA850-84, EU-9197

*7 Option: SOP-ARIETTA850-85, EU-9197

* Depending on the date of manufacture, the asterisk(*) in the model name might be an alphabetic character.

2D Tissue Tracking(2DTT)*¹

It is an application for evaluating the thickness and movements of the myocardium.

• Analysis

• Free use

Analyzes the changes in distance between any two points and angular variation from the initial time phase.

• SAX

Analyzes differences in thickness between various regions of the myocardium, as well as angular variation with the center of gravity point, based on left ventricular short axis images.

• Apex-S*²

Calculates the Longitudinal Strain and Transverse Strain of each region of the left ventricle based on the apex image. The global strain of the endocardium trace is also calculated.

• Apex-V*²

Calculates the volume, ejection fraction, center of gravity and velocity of volume change of the right and left ventricles and atrium based on the apex image.

• View

• SAX

SAX, Basal SAX, Mid SAX, Apical SAX

• APEX-S, -V

4ch, 4ch Inv, 2ch, 2ch Inv, 3ch, 3ch Inv

• Graph Type

• Line Graph: Displays analysis results for each ROI chronologically in line graphs.

• Color Graph: Displays a list the analysis results for each ROI into the colors corresponding to the color bar.

• Line & Color Graph: Displays Line Graph and Color Graph up and down.

• Bull's eye: When the view is assigned, the analysis

results for each ROI are displayed with color and numerical values in a Bull's-eye image.

• Measurements

• Point to Point: Measures the difference between two points on a graph.

• Time to Peak: Measures various values of any three time phases and the difference between them.

• 3 point: Measures various values of any three time phases and the difference between them.

• Distance: Measures the distance between any two points on an image.

*1 Option: SOP-ARIETTA850-49

*2: It is possible to perform fully automatic measurements using 2D tracking method such as Global Longitudinal Strain or SAX radial strain and ejection fraction measurements by a single click operation in combination with multiple settings.

Stress Echo analysis*

It is an examination in which the heart is subjected to stress through exercise or drugs, for example, in order to check for abnormalities of myocardium.

Stress Echo involves acquiring images before and after the application of stress, displaying the images alongside each other, synchronizing the heartbeats and looping the playback. This permits periodic evaluation of images. Stress echo report can be created using the scoring function.

• Image display modes in which image acquisition is possible: B, Each Flow modes

• Methods for acquiring images

• Temp acquisition: Acquire a preset heart rate. This method allows you to acquire color images.

• Conti acquisition: Continuous acquisition. This method cannot acquire color images.

• Protocol: Skip Stage/Skip View is possible during exam.

• Exercise stress protocols:

• Exercise Stress Echo

• Treadmill Exercise

• Bicycle Exercise

• Pharmacological stress protocols:

• DSE

• High-Dose DSE

• Low-Dose DSE

• Arbutamine

• Dipyridamole

• User's protocol:

• The user can make a protocol within 8 views X 12 stages in 1 exam.

- Full disclosure: Max. 2,481 seconds(Depends on probes and various settings)
2,481 seconds can be achieved under below conditions.
 - Probe: S121(Adult Heart)
 - Protocol: Conti. only(1Stage/1View)
 - Frequency: 30Hz
 - Scan Area: Minimum
 - Line Density: Minimum
 - Automatic labeling: Possible(Auto ON/OFF is also possible)
 - Comparing images
 - Shuffle Stage: Displays the same view of each stage for comparison.
 - Shuffle View: Displays the different views of the same stage for comparison.
 - Compare: Lines up the same view of any stage left/right for comparison.
 - Loop speed: Adjustable
 - Scoring: Possible
 - Report
 - Chart display: Display scoring results in a list.
 - Schema(Shuffle View) display: Display scoring results by a schema(list of the same Stage).
- * Option: SOP-ARIETTA850-15, PEU-LISENDO880

Tissue Doppler Imaging(TDI) analysis*

It performs velocity analysis of the data acquired in the TDI mode.

- B-mode
 - Temporal VP: Displays a graph of the motion velocity distribution in the area specified in the myocardium.
 - Regional VP: Displays a graph of the motion velocity distribution on a trace line arbitrarily specified in the myocardium.
 - Strain Rate: Displays a graph of the Strain Rate time variations in a graph.
 - Strain: Displays a graph of the Strain time variations in a graph.
 - Myocardial Thickness: The changes in myocardial thickness in the time direction of the designated endocardium and epicardium movement within the myocardium are automatically traced and displayed in a graph. The Strain in that area can also be displayed.
 - Output as a CSV file: Possible
- * Option: SOP-ARIETTA850-13

Contrast Harmonic Imaging(CHI)*

It is a function that displays images more visibly by dying them with an ultrasound contrast agent.

Settings ideal for Low, Mid, and High acoustic pressure are selectable for each contrast agents.

- CHI Method for CHI mode:
 - Wide-band Contrast Harmonic Imaging (WbC): The Pulse Inversion method enables retrieval of echoes from the ultrasound contrast agent across a broad spectrum and display them in CHI mode at a high level of sensitivity.
 - Tissue Reduction Contrast Harmonic Imaging (TrC): The Amplitude Modulation method makes it possible to reduce signals from tissue to get clearer CHI mode images.
 - CHI Mode image:
 - CHI-B/W: Displays signals from the ultrasound contrast agent as black-and-white images.
 - CHI-Color: Displays signals from the ultrasound contrast agent as color images.
 - CHI-eFLOW: Displays signals from the ultrasound contrast agent on power Doppler images.
 - Tx Mode:
 - Monitor Mode: Displays the monitor image and CHI mode image side by side.
 - Flash: This mode sends high acoustic pressure transmissions at set intervals to destroy the ultrasound contrast agent.
 - One-shot: This mode sends and receives a single shot of an ultrasound signal at high acoustic pressure in response to a manual operation.
 - Frame Rate Limit

Limits the frame rate to prevent ultrasound waves from breaking down the contrast agent.
 - Overlay display

Body motion compensation by Motion Compensated Mode is possible.
- * Option: SOP-ARIETTA850-44

Contrast Harmonic Imaging(CHI) analysis*

It is a function that lets you display the data collected in CHI mode as a Time Intensity Curve or analyze it in the form of Subtraction images.

- Analysis
 - Time Intensity Curve(TIC)

Displaying a graph of the temporal changes in the average(or median, maximum, or mode) intensity of the region of interest(ROI).

- Types of graph:
 - By ROI: Displays graphs for all frames in chronological order.
 - By Frame Number: Displays a graph for each frame number in a unit.

- Inflow Time Mapping(ITM)

This function focuses on the difference between ultrasound contrast agent inflow times and colorizes changes in brightness across the entire range of the moving image.

- Subtraction

Display subtraction images that represent the difference between frames.

- Measurement

- Point to Point: Measures the difference between two points on a graph.
- SD: Measures the analysis data for the specified time phase(Time, Max, Average, Medium, Mode, or SD).
- Wash-in: Measures the rise time of the graph from the minimum and maximum values.
- Wash-out: Measures the fall time of the graph from the minimum and maximum values.
- Fitting: Displays an approximated curve based on the start and end points, and measures the degree of increase in the signal strength.
- FWHM(Full Width at Half Maximum): Calculates the time it takes to reach -6 dB or -3 dB from the maximum value of the graph, and measures the time width between the intersection points on either side of the maximum value.
- Distance: Measures the distance between any two points on an image.
- Inflow Time Mapping(ITM) Measurement: Measures the number and proportion of color pixels at each time interval in an ITM image.
- Area Under the Curve(AUC) Measurement: Measures the area under the curve for a section on the graph.

- Output as a CSV file: Possible

* Option: SOP-ARIETTA850-44

EyeballEF*

Selection of apical four-chamber view(A4C) and apical two-chamber view(A2C) and tracing endocardium surface automatically, and measure heart volume, ejection fraction(EF), and Global Longitudinal Strain(GLS) using M. Simpson method.

- Revising Items:
 - Specifying a cross section

- Setting heartbeat analysis
- Tracing an end-diastolic image
- Specifying an end systolic frame
- Tracing an end-diastolic image

* Option: SOP-ARIETTA850-58, PEU-LISENDO880

eTRACKING*

It is a function to calculate arteriosclerosis indices such as the pressure-distortion elastic constant(E_p) and the stiffness parameter(β), which indicate the elastic characteristics of the blood vessel based on the blood vessel diameter and blood pressure values of the carotid artery.

- Stiffness parameter(β) analysis results:

- beta: Stiffness parameter
- E_p : Pressure-distortion elastic constant
- AC: Arterial compliance
- AI: Augmentation Index
- PWVbeta: Regional pulse wave velocity
- DATmax: Maximum Distension Acceleration Time

- Output as a CSV file: Possible

- Blood pressure value is necessary for this examination.

* Option: SOP-ARIETTA850-11, PEU-LISENDO880

Flow Mediated Dilatation(FMD) analysis*

It is used for the functional assessment of vessels before organic changes, such as vessel wall thickening and plaque formation, are manifested.

In an FMD test, blood flow volume is increased noninvasively, and changes in blood flow velocity and vessel diameter are recorded precisely for long periods of time.

Echo Tracking technology is used to capture and record changes in the state of the vessel at three stages such as baseline, during a vascularization and dilatation after the cuff deflation, to assess FMD.

- Output as a CSV file: Possible

- Blood pressure value is necessary for this examination.

* Option: SOP-ARIETTA850-16(includes eTRACKING software), PEU-LISENDO880

Wave Intensity(WI)*

Wave Intensity (WI) has been proposed as an indicator to allow simple determination, based on the forms of the blood pressure waveforms and velocity waveforms at any point in the arterial system, of which is predominant, the forward-traveling wave heading from the heart to the periphery, or the backward-traveling wave returning from

the periphery to the heart.

- Wave Intensity analysis:
 - Wave Intensity: Wave Intensity index value
 - Arterial Stiffness: Index values for assessing the hardness of the blood vessel
 - Diameter: Distension waveform
 - Flow Velocity: Blood flow velocity measurement value
 - Output as a CSV file: Possible
 - Blood pressure value is necessary for this examination.
- * Option: SOP-ARIETTA850-34 (includes eTRACKING software), PEU-LISENDO880

Detective Flow Imaging(DFI)*

Removes motion artifacts from the feature amount of movement obtained by analyzing the received signals in the ROI, and displays images in colors that vary according to the signal intensity. Blood flow is displayed at a high frame rate and is little affected by body movement.

* Option: SOP-ARIETTA850-105

General Specifications

Acoustic Power

- 0 to 100%

Preset Function

- 100 kinds(Max. 10 kinds per each probe)
- Preset contents storable in USB memory
- Quick Scanning Selector(Q.S.S.)
 - Image modifying parameters (e.g. Gain, frequency, depth) of your choice can be registered. (Up to 4 sets per preset)
 - These parameters can immediately be registered and selected by touch panel during examinations.
- Preset is booted up in conjunction with ID information (BodyParts or etc.)

Characters and graphic displays

- Character input area
 - ID, name, age, sex, retained text (Can be corrected after exam.)
- Input is possible with virtual keyboard on LCD panel
- Automatic Annotation Labeling
 - 800 words(User registration is possible. 10 classes.)
- Body mark:
 - 38 kinds are available per each region.
 - 6 regions+1 user is able to register.
 - Probe mark: 4 kinds
 - Display position: changeable
 - Fetus mark
 - Rotatable(Only single horizontal fetus marks)
- Assist line display

Menu control

- 10.4-inch color TFT LCD touch panel

Active Probe Ports

- For electronic scanning probes: 6 (4 active, 2 parking)
- For independent probes*: 1

* Option: EU-9187B

Input/Output Signals

- Data Input/Output
 - USB2.0: 5 channels (Main unit 2+ Operation Panel 3)
 - USB3.0: 1 channel
- Digital Video Input/Output

Input

- DVI-D digital:

Resolution: WXGA++(1600x900)

Output

- DVI-D digital
 - Resolution: WXGA++(1600x900)
 - Digital video with HDMI connector*
 - Resolution: FHD(1920x1080), XGA(1024x768), VGA(640x480)
 - * Option: EU-9205
 - Analog Video Input/Output
- #### Input
- Y/C: 1 channel
- #### Output
- Color composite (BNC): 1 channel
 - Y/C: 1 channel
 - Network: LAN(Wired, Wireless)
 - Others
 - Audio (L/R): 2 channels (Output 1, Input 1)

Storage

- SSD
- HDD

Viewing Monitor

- 22 inch Organic EL monitor(OLED)
 - Resolution: FHD(1920 x 1080)
- Tilt and swivel are possible.
- Height adjustment and swivel together with operation panel.

Safety Regulation

- IEC 60601-1 Ed.3.0: 2005, IEC 60601-1 Ed.3.1: 2012
- Class I, Type BF

Environmental Requirements

- In Operation
 - Temperature: +10 to +40 degrees C
 - Relative Humidity: 30 to 75%(non condensing)
 - Atmospheric pressure: 700 to 1060 hPa
 - Altitude: Up to 3000 m
- In Storage/Transportation
 - Temperature: -10 to +50 degrees C (0 to +50 degrees C for mechanical probes)
 - Relative Humidity: 10 to 90%(non condensing)
 - Atmospheric pressure: 700 to 1060 hPa

Power Requirement

- 100 to 120/ 200 to 240 V \pm 10%, 50 or 60 Hz, Max. 1300 VA(with optional recorders connected)

Max. 900 VA(main unit only)

- Shut down tool
Hibernation *

*: The condition is saved even if the power is unplugged.

Dimensions

- 55 cm(W) × 90 cm(D) ×122 to 169.5 cm(H)

Weight

- Main unit only: 145 kg±10%
- Main unit and all optional equipment: 163 kg±10%

System Configuration

ARIETTA 850 main unit
(includes a viewing monitor and Alphanumeric keyboard)

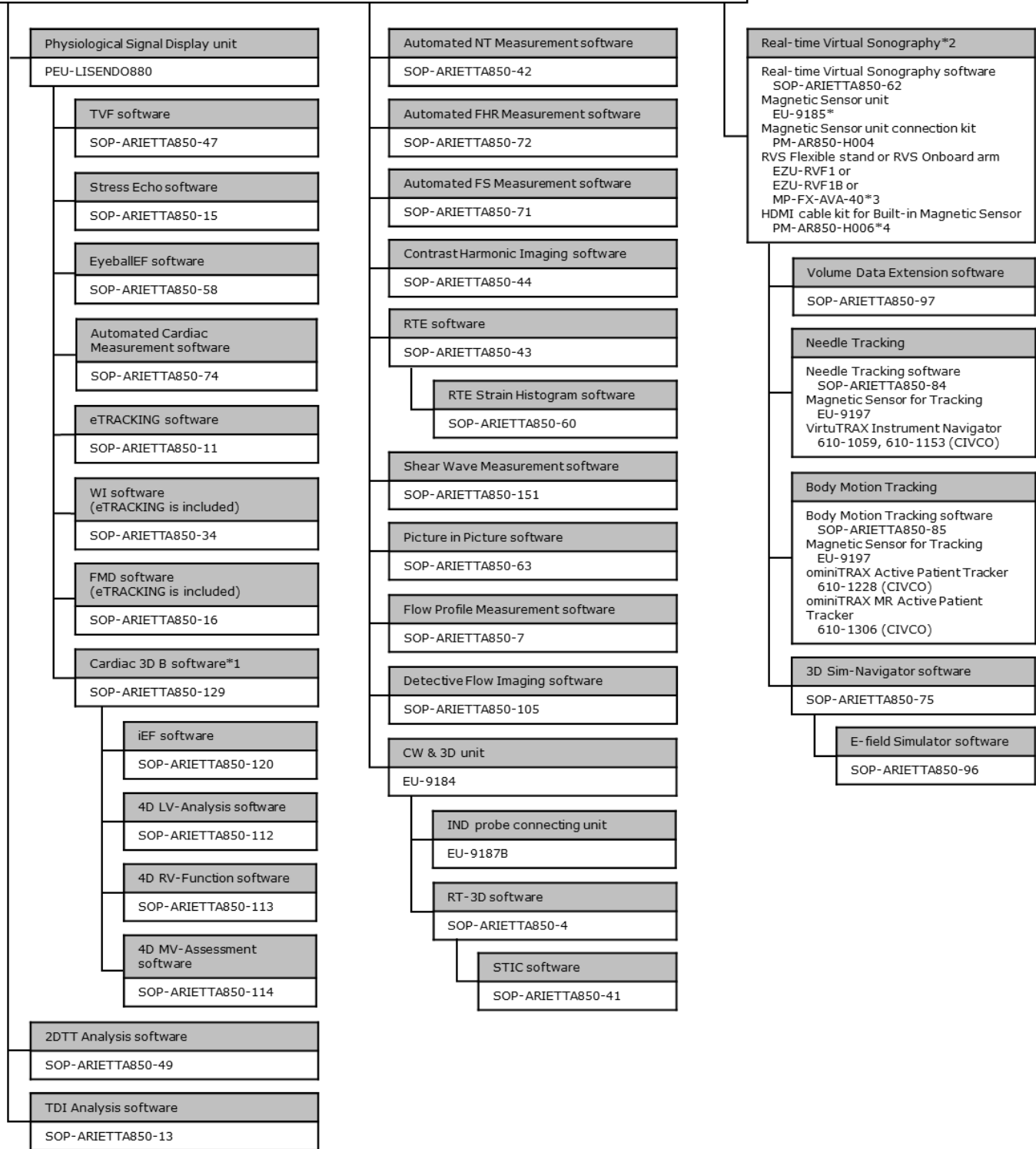

Continue to the next page

ARIETTA 850 main unit

(includes a viewing monitor and Alphanumeric keyboard)

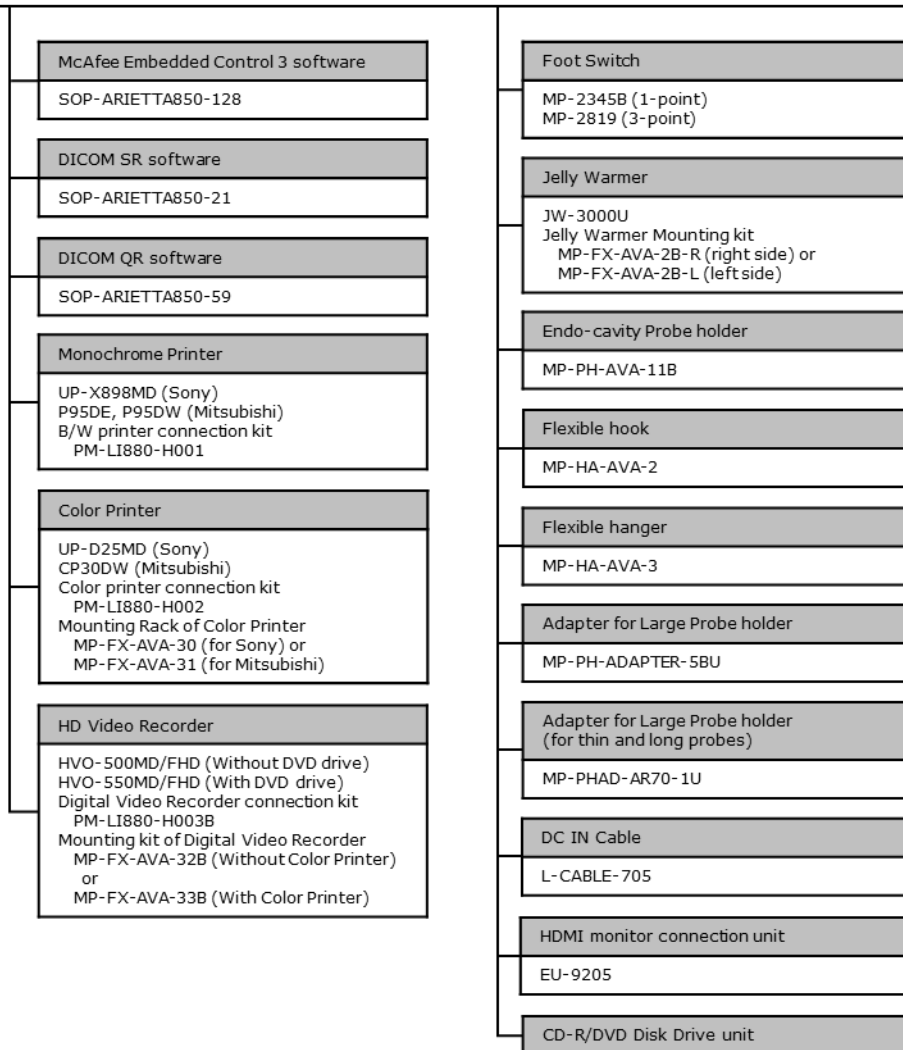

* Depending on the date of manufacture, the asterisk(*) in the model name might be an alphabetic character.

*1 EU-9183 or EU-9207 is necessary.

*2 Most of attachment/adaptor is optional. See "Optional Probes" description.

*3 Can not be used simultaneously with the color printer.

*4 Necessary when performing RVS with a built-in magnetic sensor probe.

OPTIONAL PROBES

Electronic convex sector probes

Application (description)	Model	Frequency range (MHz)	Scanning angle (degrees)	Optional accessories
Abdominal	C22K	6.0-1.0	82	Puncture Adapter MP-2781 MP-2781-5 MP-2781-25 Bracket 614-108, 614-109(CIVCO)*1*5
Abdominal	C22P	6.0-1.0	74	Needle Guide Bracket EZU-PA7C2*1 MP-2824 Magnetic Position Sensor Attachment(Standard) RV-012*2
Abdominal	C23	6.0-1.0	110*	Verza Bracket 644-095, 644-096(CIVCO)*1*5 BX2 Needle Guide 644-094(CIVCO)*1*5 Magnetic Position Sensor Attachment RV-017*2 Waterproof Case WP-001
Abdominal	C23RV	6.0-1.0	110*	Verza Bracket 644-095, 644-096(CIVCO)*1*5 BX2 Needle Guide 644-094(CIVCO)*1*5 Magnetic Position Sensor Attachment RV-017*3 Waterproof Case WP-001
Abdominal	C251	5.0-1.0	70	Bracket 644-082, 644-083(CIVCO)*1*5 Magnetic Position Sensor Attachment RV-004*2
Abdominal	C252	6.0-1.0	70	Bracket 644-082, 644-083(CIVCO)*1*5 Magnetic Position Sensor Attachment RV-004*2
Abdominal	C25P*4	5.0-1.0	70	Biopsy Attachment EZU-PA7B1-1 EZU-PA7B1-2 EZU-PA7B1-3 EZU-PA7B1-4 EZU-PA7B1-C Magnetic Position Sensor Attachment RV-005*2
Abdominal	C35	8.0-2.0	70	Bracket 644-082, 644-083(CIVCO)*1*5 Magnetic Position Sensor Attachment RV-004*2
Transvaginal Transrectal	C41B	10.0-2.0	200	Puncture Guide Tube MP-2445 Magnetic Position Sensor Attachment RV-013*2 Waterproof Case WP-001

Transrectal	C41RP	9.0-2.0	180	Puncture Guide Tube MP-2452-G18(Standard:2pcs) MP-2452-G21/-G16/-G14(Option) Waterproof Case WP-001
Transvaginal	C41V1	10.0-2.0	200	Puncture Adapter EZU-PA7V Magnetic Position Sensor Attachment RV-002*2
Abdominal	C42	8.0-4.0	80	Needle Guide Bracket EZU-PA532 Bracket 644-077, 644-078(CIVCO)*1*5 Magnetic Position Sensor Attachment RV-006*2 RV-007(for EZU-PA532)*2
Intraoperative	C42K	10.0-4.0	65	Puncture Adapter MP-2458 Bracket 614-068, 614-100(CIVCO)*1*5
Intraoperative	C42T	10.0-3.0	65	Magnetic Position Sensor Attachment RV-003*2 Waterproof Case WP-001
Abdominal	C421	12.0-3.0	100*	Verza Bracket 644-098, 644-099(CIVCO)*1*5 Magnetic Position Sensor Attachment RV-017*2 Waterproof Case WP-001

*When Wide Scanning is ON.

Electronic linear probes

Application (description)	Model	Frequency range (MHz)	Scanning width (mm)	Optional accessories
Intraoperative	L31KP	9.0-2.0	6	Puncture Adapter MP-2450(Standard) Waterproof case WP-001
Small Organ	L34	7.0-3.0	38	Coupler EZU-PA3C1H Bracket 644-079, 644-080(CIVCO)*1*5
Small Organ	L35	9.0-2.0	45	Magnetic Position Sensor Attachment RV-017*2 CIVCO Verza Needle Guide 610-1500-24(CIVCO)*5 No Bracket for puncture (Verza Needle Guide can be attached directly)
Intraoperative	L43K	12.0-2.0	26	Waterproof Case WP-001
Peripheral Vessel	L441	12.0-2.0	38	Bracket 644-075, 644-076(CIVCO)*1*5
Intraoperative	L44K	14.0-2.0	42	Waterproof Case WP-001
Intraoperative	L46K1	14.0-2.0	63	Waterproof Case WP-001
Intraoperative	L51K	15.0-3.0	13	Waterproof Case WP-001

Intraoperative	L53K	15.0-3.0	25	Waterproof Case WP-001
Intraoperative	L44LA	13.0-2.0	36	-
Intraoperative	L44LA1	13.0-2.0	38	Waterproof Case WP-001
Small Organ	L55	13.0-5.0	50	Needle Guide Bracket EZU-PA7L2* ¹ Elastography Stabilizer EL-001 Magnetic Position Sensor Attachment RV-008* ²
Small Organ	L64	18.0-5.0	38	Needle Guide Bracket EZU-PA7L3* ¹ Elastography Stabilizer EL-002 Magnetic Position Sensor Attachment RV-009* ² Acoustic Coupler Attachment EZU-TEATC2 Acoustic Coupler EZU-TECPL1(for RTE) SF-001

Electronic phased array sector probes

Application (description)	Model	Frequency range (MHz)	Scanning angle* (degrees)	Optional accessories
Cardiac Adult	S121	5.0-1.0	120	-
Cardiac Pediatric	S31	9.0-2.0	100	-
Neonatal Cardiology	S42	14.0-3.0	100	-
Cardiac Adult, TEE	S3ESL1	9.0-2.0	100	Mouthpiece(Standard) SP-7901 Waterproof Case WP-001
Cardiac, TEE	S3ESEL	8.0-2.0	100	Mouthpiece(Standard) SP-7901
Cardiac, TEE	S3ESCLS	8.0-2.0	100	Mouthpiece(Standard) MP-2787

*When Wide Scanning is ON.

CMUT Probes (linear probes)

Application	Model	Frequency range (MHz)	Scanning width (mm)	Optional accessories
Small Organ	SML44	22.0-2.0	38	Magnetic Position Sensor Attachment RV-014* ²

RT-3D (4D) Probes*

* SOP-ARIETTA850-4 and EU-9184 are necessary.

Application	Model	Frequency range (MHz)	Scanning angle (degrees)	Optional accessories
Fetal	VC34	7.0-2.0	70	-
Fetal	VC35	8.0-2.0	72	-
Transvaginal	VC41V	8.0-2.0	145	-

Bi-plane probe

Application (description)	Model	Frequency range (MHz)	Scanning angle (degrees)	Optional accessories	
Transrectal	CC41R	8.0-4.0	100/120	Puncture Adapter EZU-PA5V Puncture Guide Fixture EZU-PA3U Magnetic Position Sensor Attachment RV-010* ² Waterproof Case WP-001	
Transrectal	CC41R1	10.0-2.0	180/180	Puncture Adapter EZU-PA5V Magnetic Position Sensor Attachment RV-015* ² Waterproof Case WP-001	
Transrectal	CC41R2	10.0-2.0	200**/200**	Gap adapter OP-001 (Standard) CIVCO Needle Guides 644-101* ⁵ /644-102* ⁵ Magnetic Position Sensor Attachment RV-020* ² Waterproof case WP-001	
Transrectal	C41L47RP	Convex	8.0-4.0	200	Puncture Guide Fixture EZU-PA3U Magnetic Position Sensor Attachment RV-011* ²
		Linear	10.0-5.0	64mm	
Transrectal	CL4416R	Convex	10.0-2.0	180	Puncture Guide Fixture BA-001 Magnetic Position Sensor Attachment RV-011* ² Waterproof Case WP-001
		Linear	14.0-2.0	63mm	
Transrectal	CL4416R1	Convex	10.0-2.0	200*	Puncture Adapter BA-001 Magnetic Position Sensor Attachment RV-021* ² Waterproof case WP-001
		Linear	14.0-2.0	63mm	

*When Wide Scanning is ON.

** Always in use.

Matrix 3D(4D) Probes*

***SOP-ARIETTA850-129, EU-9183 or EU-9207, PEU-LISENDO880** are necessary

Application (description)	Model	Frequency range (MHz)	Scanning angle (degrees)	Optional accessories
Cardiac Adult, TTE	MXS1	5.0-1.0	90	-

Independent CW Doppler Probes*

* Independent probe connection unit **EU-9184 and EU-9187B** are necessary.

Application	Model	Frequency range (MHz)	Optional accessories
Cardiac Adult	UST-2265-2	2.0	-
Cardiac Adult	UST-2266-5	5.0	-

Electrical Radial Probes

Application	Model	Frequency range (MHz)	Scanning angle (degrees)	Optional accessories
Transrectal	R41R	10.0-5.0	360	Waterproof Case WP-001
Transrectal	R41RL	10.0-5.0	360	Waterproof Case WP-001

*1: Needle Guide Kit(CIVCO) is necessary.

*2: Necessary to perform RVS.

*3: Necessary to perform RVS with an external magnetic sensor.

*4: One of puncture adapter is necessary to use needle.

*5: CIVCO products are manufactured and sold by CIVCO Medical Solutions. It does not suggest that CIVCO products describe in this specification are commercially available in all countries and regions.

Probes and available functions

Basic Functions

	Compound	Trapezoid	Wide Scanning	B steer	eFocusing	Acoustic Noise Reduction	Near-field Noise Reduction	Real-time Biplane	OMNI mode	FAM	TGC Enh(B)	TGC Enh(Color)	TDI mode	HI Frame(B)	HI Frame(Color)	Puncture Guide Line	Needle Emphasis	Brachy Grid Display	CW mode	Assist Line	THI(FnT)	THI(WbT)	THI(HdT)	Dual Gate Doppler
C22K	✓				✓	✓	✓			✓						✓	✓					✓	✓	✓
C22P	✓				✓	✓	✓			✓						✓	✓				✓	✓	✓	✓
C23	✓		✓		✓	✓	✓			✓		✓				✓	✓						✓	✓
C23RV	✓		✓		✓	✓	✓			✓		✓				✓	✓						✓	✓
C251	✓				✓	✓	✓			✓			✓	✓	✓	✓	✓		✓		✓	✓	✓	✓
C252	✓				✓	✓	✓			✓		✓	✓	✓	✓	✓	✓		✓		✓	✓	✓	✓
C25P	✓				✓	✓	✓			✓						✓	✓				✓	✓	✓	✓
C35	✓				✓	✓	✓			✓		✓	✓	✓	✓	✓	✓		✓		✓	✓	✓	✓
C41B	✓				✓	✓	✓			✓						✓	✓					✓	✓	✓
C41RP	✓				✓	✓	✓			✓						✓	✓						✓	✓
C41V1	✓				✓	✓	✓			✓						✓	✓					✓	✓	✓
C42	✓				✓	✓	✓			✓						✓	✓		✓		✓	✓	✓	✓
C42K	✓				✓	✓	✓			✓						✓	✓						✓	✓
C42T	✓				✓	✓	✓			✓													✓	✓
C421	✓		✓		✓	✓	✓			✓						✓	✓		✓		✓	✓	✓	✓
CC41R	✓				✓		✓	✓		✓						✓	✓					✓		✓
CC41R1	✓				✓		✓	✓		✓						✓	✓					✓	✓	✓
CC41R2	✓		✓*		✓		✓	✓		✓						✓	✓					✓		✓
R41R							✓																✓	✓
R41RL							✓																✓	✓
L31KP	✓	✓				✓	✓			✓						✓								✓
L34	✓	✓		✓	✓	✓	✓			✓	✓					✓	✓		✓			✓	✓	✓
L35	✓	✓		✓	✓	✓	✓			✓	✓	✓				✓	✓		✓	✓		✓	✓	✓
L43K	✓	✓		✓	✓	✓	✓			✓													✓	✓
L441	✓	✓		✓	✓	✓	✓			✓		✓			✓	✓	✓		✓			✓	✓	✓
L44K	✓	✓		✓	✓	✓	✓			✓													✓	✓
L46K1	✓	✓		✓	✓	✓	✓			✓													✓	✓
L51K	✓	✓		✓	✓	✓	✓			✓													✓	✓
L53K	✓	✓		✓	✓	✓	✓			✓													✓	✓

	Compound	Trapezoid	Wide Scanning	B steer	eFocusing	Acoustic Noise Reduction	Near-field Noise Reduction	Real-time Biplane	OMNI mode	FAM	TGC Enh(B)	TGC Enh(Color)	TDI mode	HI Frame(B)	HI Frame(Color)	Puncture Guide Line	Needle Emphasis	Brachy Grid Display	CW mode	Assist Line	THI(Fnt)	THI(WbT)	THI(HdT)	Dual Gate Doppler	
L44LA	✓	✓		✓	✓	✓	✓			✓													✓	✓	
L44LA1						✓	✓			✓														✓	✓
L55	✓	✓		✓	✓	✓	✓			✓		✓	✓			✓	✓						✓	✓	
L64	✓	✓		✓	✓	✓	✓			✓		✓				✓	✓			✓		✓	✓	✓	
SML44	✓	✓		✓	✓	✓	✓			✓		✓								✓		✓	✓	✓	
S121			✓		✓	✓	✓			✓		✓	✓	✓	✓				✓		✓	✓		✓	
S31			✓			✓	✓			✓		✓	✓		✓				✓		✓	✓		✓	
S42			✓			✓	✓			✓		✓	✓		✓				✓		✓	✓		✓	
S3ESL1			✓			✓	✓			✓		✓	✓		✓				✓					✓	
S3ESEL			✓			✓	✓			✓		✓	✓		✓				✓					✓	
S3ESCLS			✓			✓	✓			✓		✓	✓		✓				✓					✓	
VC34	✓				✓	✓	✓			✓		✓	✓	✓	✓							✓	✓	✓	
VC35	✓				✓	✓	✓			✓		✓	✓	✓	✓							✓	✓	✓	
VC41V	✓					✓	✓		✓	✓			✓									✓	✓	✓	
MXS1					✓	✓	✓	✓		✓		✓	✓	✓	✓				✓		✓			✓	
C41L47RP(CV)	✓				✓	✓	✓			✓								✓				✓		✓	
C41L47RP(LN)	✓	✓		✓	✓	✓	✓			✓						✓						✓		✓	
CL4416R(CV)	✓				✓		✓			✓								✓				✓	✓	✓	
CL4416R(LN)	✓	✓		✓	✓		✓			✓						✓						✓	✓	✓	
CL4416R1(CV)	✓		✓		✓		✓			✓								✓				✓		✓	
CL4416R1(LN)	✓	✓		✓	✓		✓			✓						✓						✓		✓	
UST-2265-2																			✓						
UST-2266-5																			✓						

Optional Functions

	CHI(Low)	CHI(Mid)	CHI(High)	Panoramic	RTE	SWM	IATT	SWE	RVS	Needle Tracking	Cardiac 3D	Real time 3D	STIC	Stress echo	eTRACKING	FMD	Wave Intensity	CHI-eFLOW	DFI mode	
C22K	✓	✓																		
C22P	✓	✓	✓						✓	✓										
C23	✓	✓	✓						✓	✓								✓	✓	
C23RV	✓	✓	✓						✓	✓								✓	✓	
C251	✓	✓	✓	✓	✓	✓	✓		✓	✓								✓	✓	
C252	✓	✓	✓	✓	✓	✓	✓	✓	✓	✓								✓	✓	
C25P	✓	✓	✓						✓	✓										
C35	✓	✓		✓	✓				✓											✓
C41B	✓	✓			✓				✓											
C41RP																				
C41V1	✓	✓			✓				✓											
C42				✓	✓				✓											
C42K					✓															
C42T	✓	✓			✓				✓											
C421	✓	✓		✓	✓				✓	✓										✓
CC41R	✓	✓			✓				✓											
CC41R1					✓				✓											
CC41R2	✓	✓			✓				✓											
R41R					✓															
R41RL					✓															
L31KP																				
L34	✓	✓		✓	✓										✓	✓	✓			
L35	✓	✓		✓	✓				✓	✓								✓	✓	
L43K	✓	✓			✓															
L441	✓	✓		✓	✓										✓	✓	✓			✓
L44K	✓	✓			✓															
L46K1	✓	✓			✓															
L51K	✓	✓			✓															
L53K					✓															

	DFI mode	CHI-eFLOW	Wave Intensity	FMD	eTRACKING	Stress echo	STIC	Real time 3D	Cardiac 3D	Needle Tracking	RVS	SWE	iATT	SWM	RTE	Panoramic	CHI(High)	CHI(Mid)	CHI(Low)
L44LA															✓		✓	✓	
L44LA1																			
L55	✓		✓	✓	✓						✓				✓	✓		✓	
L64			✓	✓	✓						✓			✓	✓				
SML44			✓	✓	✓						✓				✓				
S121		✓				✓													
S31						✓													
S42						✓													
S3ESL1																			
S3ESEL																			
S3ESCLS																			
VC34							✓	✓											
VC35							✓	✓											
VC41V								✓						✓					
MXS1									✓										
C41L47RP(CV)										✓					✓				
C41L47RP(LN)										✓					✓				
CL4416R(CV)										✓									
CL4416R(LN)										✓					✓				
CL4416R1(CV)										✓									
CL4416R1(LN)										✓					✓				
UST-2265-2																			
UST-2266-5																			

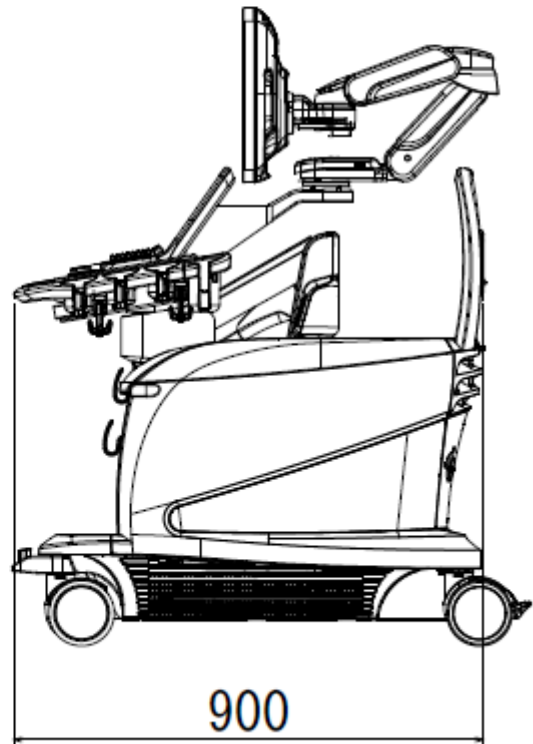
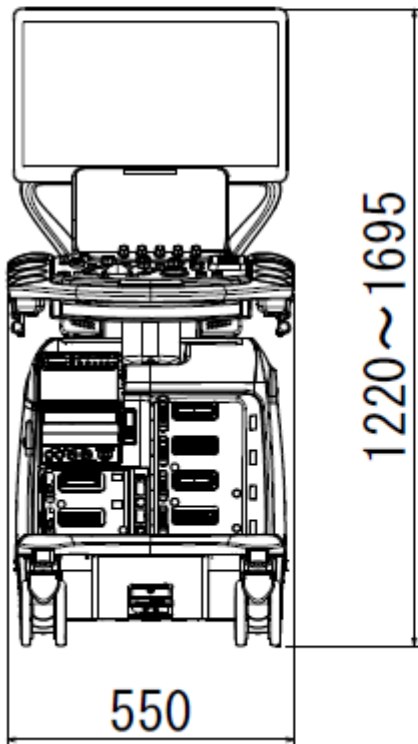
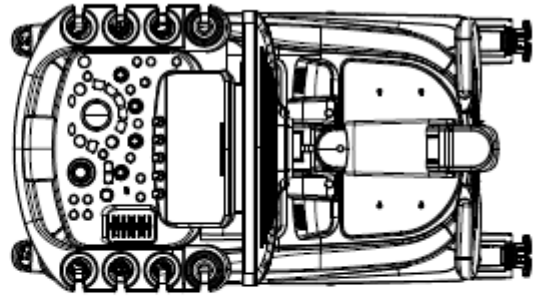

-
- The specifications are subject to change without notice.
 - The standard components and optional items differ depending on the country.
Not all products are marketed in all countries.
Please contact your local FUJIFILM Healthcare Corporation distributors for details.
 - ARIETTA, HdTHI, eFocusing, HI REZ, Carving Imaging, Real-time Tissue Elastography, Real-time Virtual Sonography, 4Dshading and LISENDO are registered trademarks or trademarks of FUJIFILM Healthcare Corporation in Japan and other countries.
 - ALOKA is a registered trademark or trademark of Nippon RayTech Co., Ltd. in Japan and other countries.
 - FUJIFILM and FUJIFILM logo are registered trademarks or trademarks of FUJIFILM Corporation.
 - McAfee is a registered trademark or trademark of McAfee LLC in the United States and other countries.
 - DICOM is a registered trademark of the National Electrical Manufacturers Association in the United States for its standards publications relating to digital communications of medical information.
 - Excel is a registered trademark or trademark of Microsoft Corporation in the United States and other countries.
 - SYNAPSE are registered trademarks or trademarks of FUJIFILM Corporation in Japan and other countries.
 - TOMTEC, LV-Function, Beutel and D' Art are registered trademarks or trademarks of TOMTEC Imaging Systems GmbH in Germany and other countries.
 - This document is applicable to ARIETTA 850

FUJIFILM Healthcare Corporation

9-7-3, Akasaka, Minato-ku, Tokyo 107-0052, Japan