

### TECHNICAL SPECIFICATION

- 1- Unless otherwise specified, all dimensions are in mm.
- 2- Columns are manufactured in compliance to EN40
- 3- Materials:
  - 3.1 For shaft EN 10025 Steel grade is S235 JR
  - 3.2 Anchor bolts grade 10.40
  - 3.3 Brackets pipes ST 37
  - 3.4 All screws, nuts, bolts steel grade ISO 4016
- 4- Hot dip galvanization as per ENISO 1461/ASTM A123

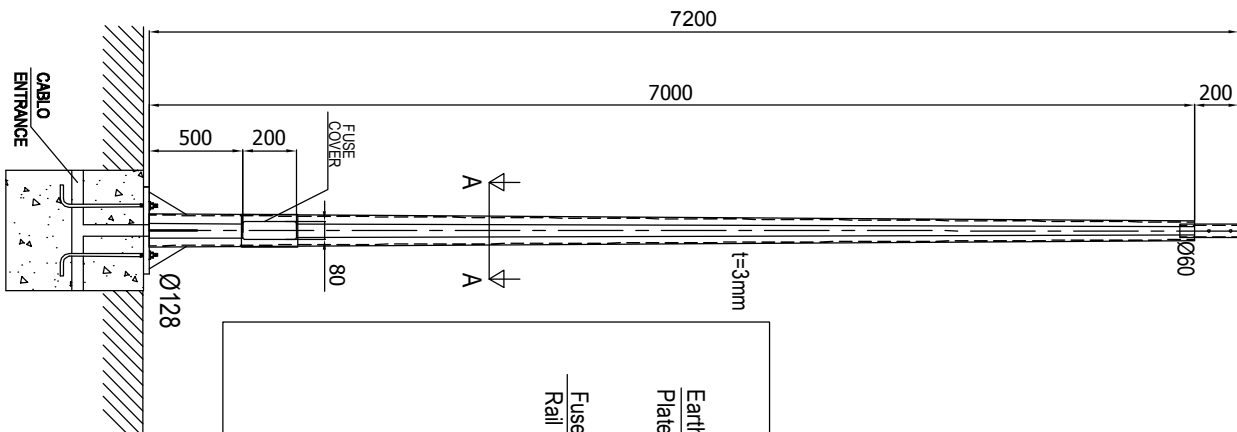
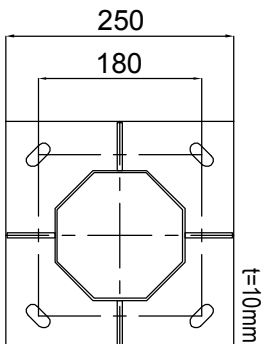
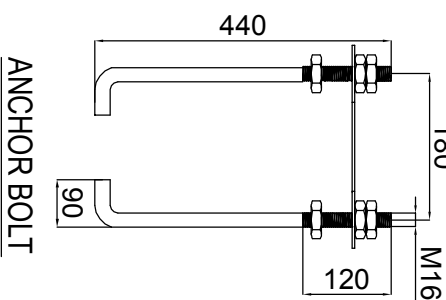
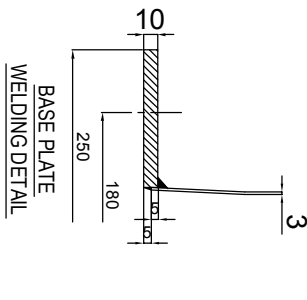
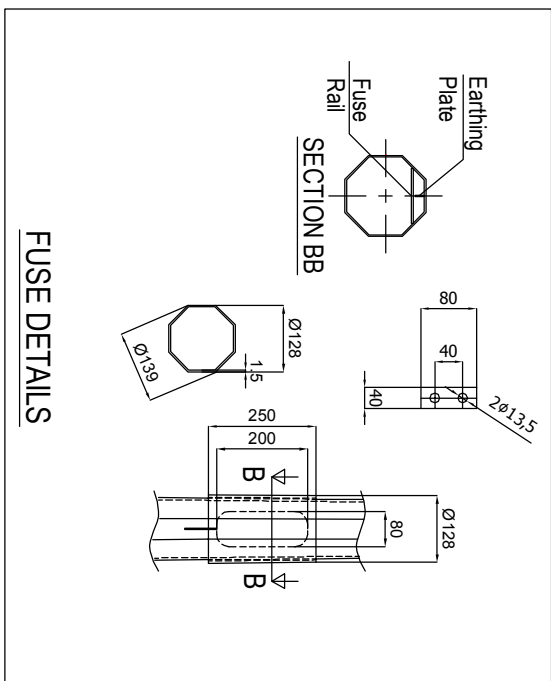
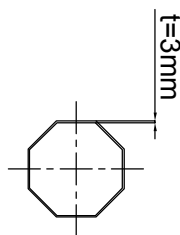
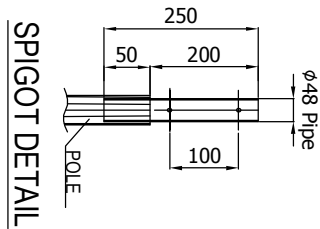

PROJECT NAME

7m Octagonal Lighting Pole AD 70



DRAWN BY		CONTROL		APPROVE	
TUGBA KALCI	ETEM M. YILMAZ	ZAFER KORKMAZ	SCALE	NTS	
DATE	DRAWING NO	REVISION	00		
T15-515-B					