

Presă hidraulică pentru ateliere mecanice 1010 x 300 mm HD 100 cu motor, pompa manuală și cilindru deplasabil

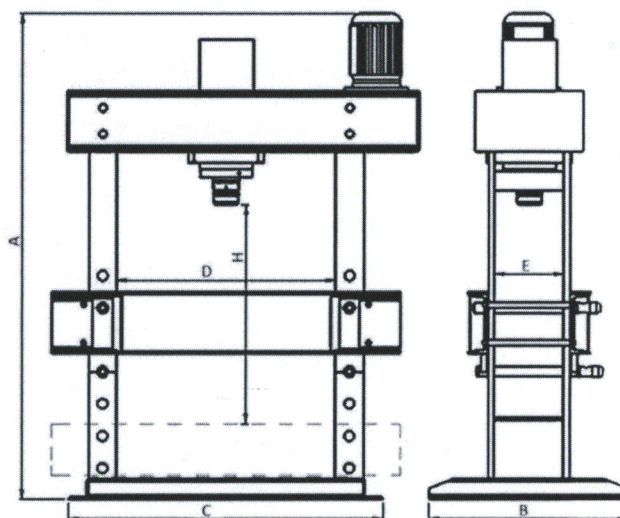

Date tehnice	U.M.
Forta presare	1000 kN
Distanța între coloane (D)	1010 mm
Distanța între coloane (E)	300 mm
Distanța masă-berbec (H)	900 mm
Cursa berbec	400 mm
Putere motor	4 kW
Capacitate pompa	11 L
Viteza de apropiere	7,12 mm/s
Viteza de întoarcere	13,42 mm/s
Înălțime (A)	2450 mm
Lungime (B)	850 mm
Latime (C)	1600 mm

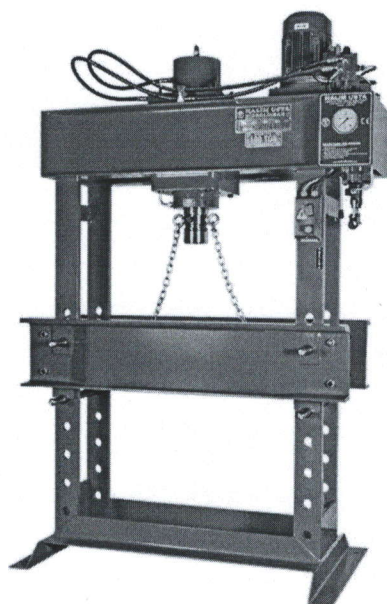



VSC UNITECH SRL

2032, str. Burebista, 108, mun. Chişinău, Republica Moldova

tel: +373 (069) 101679; +373 (069) 161712; +373 (060) 210604

e-mail: vsc.unitech@gmail.com; sales@unitools.md

web: www.vscunitech.md www.unitools.md



www.unitools.md

Greutate

1000 kg

Dotari standard:

- Cilindri de actionare sunt cromati
- Cadru masinii este din otel sudat
- Manometru presiune ulei
- Sistem de reglare a presiunii
- Manual de utilizare



Walcom



CORMAK
Strunguri prelucrare lemn si metal



UNIOR