

# HI933

## KARL FISCHER VOLUMETRIC TITRATOR



Dear  
Customer,

Thank you for choosing a Hanna Instruments product.

Please read this instruction manual carefully before using this instrument. This manual will provide you with the necessary information for the correct use of this instrument, as well as a precise idea of its versatility.

If you need additional technical information, do not hesitate to e-mail us at [tech@hannainst.com](mailto:tech@hannainst.com) or view our worldwide contact list for a Hanna Instruments representative near you at [www.hannainst.com](http://www.hannainst.com).

© 2019 Hanna Instruments

All rights are reserved. Reproduction in whole or in part is prohibited without the written consent of the copyright owner, Hanna Instruments Inc., Woonsocket, Rhode Island, 02895, USA.



# INTRODUCTION

The **HI933** is an automatic volumetric Karl Fischer titrator with high accuracy, great flexibility and repeatability. It is designed to perform titrations for a variety of sample types/matrices, allowing the user to obtain both good results and high-speed analysis.

The main attributes of the **HI933** titrator are:

- Small footprint, requires minimal bench space
- Casing made with strong, chemically resistant plastic
- Powerful built-in algorithms for termination criteria based on fixed mV endpoint or absolute/relative drift
- Titrant standardization and sample analysis averaging
- Minimized water vapor entry with the Sealed Solvent System
- Balance interface for automatic weighing
- Support for 100 titration methods
- User-customizable reports
- Clearly displayed warning and error messages

This manual provides information regarding installation and functionality of the titrator and refined operation suggestions. Before using the titrator, it is recommended you become familiar with its various features and functionality.

This manual is divided into four parts:

## PART 1: QUICK START GUIDE

Helps the user quickly setup and operate **HI933** Karl Fisher titrator. It covers basic connections, user interface and how to run a titration.

## PART 2: INSTRUCTION MANUAL

Provides a comprehensive description of the operating principles user interface, general options, methods, titration mode, optimization, maintenance, etc.

## PART 3: APPLICATIONS

Contains complete instructions for commonly-used analyses. Additional methods and method packs are available; contact your local Hanna Instruments office for more details.

## PART 4: TITRATION THEORY

Outlines the principles of operation of the titrator. It covers the chemistry of titrations, titration types and result calculations.



## TABLE OF CONTENTS

### PART 1: QUICK START GUIDE

1. SAFETY MEASURES .....	1-2
2. TITRATOR CONNECTIONS .....	1-3
2.1. FRONT VIEW .....	1-3
2.2. REAR VIEW .....	1-3
3. USER INTERFACE .....	1-4
3.1. KEYPAD .....	1-4
3.2. DISPLAY .....	1-4
4. LANGUAGE .....	1-5
5. CONTEXTUAL HELP .....	1-5
6. METHODS .....	1-5
6.1. STANDARD METHODS .....	1-5
6.2. USER-DEFINED METHODS .....	1-5
7. PREPARATION .....	1-6
7.1. SETTING UP THE TITRATOR .....	1-6
7.2. OBTAINING THE REAGENTS .....	1-6
7.3. PRIMING THE BURETTE .....	1-6
8. THE FIRST TITRATION .....	1-7
8.1. METHOD SELECTION .....	1-7
8.2. SETTING METHOD PARAMETERS .....	1-7
8.3. SETTING UP TITRATION REPORT .....	1-7
8.4. FILLING TITRATION BEAKER WITH SOLVENT .....	1-8
8.5. PREPARING THE SOLVENT FOR SAMPLES .....	1-8
8.6. PREPARING AND INTRODUCING THE SAMPLE .....	1-8
8.7. PERFORMING A TITRATION .....	1-9
8.8. UNDERSTANDING THE DISPLAYED INFORMATION .....	1-9
8.9. VIEWING GRAPH DURING TITRATION .....	1-10
8.10. TITRATION TERMINATION .....	1-10
8.11. RESULTS .....	1-11
8.12. VIEWING THE LAST TITRATION DATA .....	1-11
8.13. PRINTING THE TITRATION REPORT .....	1-11
8.14. SAVING DATA TO USB STORAGE DEVICE .....	1-12
8.15. TITRATION REPORT .....	1-13

### PART 2: INSTRUCTION MANUAL

1. SETUP .....	2-2
1.1. UNPACKING .....	2-2
1.2. SAFETY MEASURES .....	2-3
1.3. TECHNICAL SPECIFICATIONS .....	2-4
1.4. INSTALLATION .....	2-5
2. USER INTERFACE .....	2-13
2.1. START UP .....	2-13
2.2. KEYPAD .....	2-13
2.3. DISPLAY .....	2-15
2.4. MENU NAVIGATION .....	2-16
3. GENERAL OPTIONS .....	2-18
3.1. SAVE FILES TO USB STORAGE DEVICE .....	2-18
3.2. RESTORE FILES FROM USB STORAGE DEVICE .....	2-19
3.3. STANDBY MODE .....	2-20



3.4. STANDBY DURATION .....	2-20
3.5. TITRANT DATABASE .....	2-21
3.6. STANDARD DATABASE.....	2-21
3.7. ESTIMATED CELL VOLUME .....	2-22
3.8. USB LINK WITH PC.....	2-22
3.9. SETUP BALANCE INTERFACE .....	2-23
3.10. STIRRER.....	2-24
3.11. PRINTER MODE.....	2-24
3.12. DATE AND TIME SETTING .....	2-25
3.13. DISPLAY SETTINGS.....	2-25
3.14. BEEPER.....	2-26
3.15. LANGUAGE.....	2-26
3.16. CALIBRATION CHECK.....	2-27
3.17. RESET TO DEFAULT SETTINGS.....	2-27
3.18. OPTIMIZE MEMORY SPACE .....	2-28
3.19. UPDATE SOFTWARE.....	2-28
4. TITRATION METHODS .....	2-29
4.1. SELECTING METHODS .....	2-29
4.2. STANDARD METHODS .....	2-29
4.3. USER METHODS.....	2-31
4.4. VIEWING / MODIFYING METHOD .....	2-32
4.5. METHOD OPTIONS.....	2-33
4.6. PRINTING .....	2-58
5. TITRATION MODE .....	2-59
5.1. IDLE.....	2-59
5.2. PRE-TITRATION .....	2-60
5.3. DRIFT ANALYSIS (AUTOMATIC DETERMINATION ENTRY ONLY) .....	2-60
5.4. STANDBY.....	2-61
5.5. SAMPLE ANALYSIS.....	2-62
5.6. TITRANT STANDARDIZATION .....	2-67
6. AUXILIARY FUNCTIONS.....	2-70
6.1. AIR PUMP.....	2-70
6.2. BURETTE .....	2-71
6.3. STIRRER.....	2-73
6.4. RESULTS .....	2-73
7. MAINTENANCE AND PERIPHERALS.....	2-77
7.1. BURETTE MAINTENANCE .....	2-77
7.2. PROBE MAINTENANCE .....	2-80
7.3. PERIPHERALS .....	2-80
8. METHOD OPTIMIZATION .....	2-83
8.1. TITRATION SETTINGS.....	2-83
8.2. CONTROL PARAMETERS.....	2-83
8.3. THE SAMPLE.....	2-87
8.4. KARL FISCHER REAGENT SYSTEM.....	2-92
9. ACCESSORIES .....	2-95
9.1. TITRANTS.....	2-95
9.2. SOLVENTS .....	2-95
9.3. STANDARDS.....	2-96
9.4. TITRATOR COMPONENTS.....	2-97



## PART 3: APPLICATIONS

HI8001EN 5.0 mg/mL TITRANT STANDARDIZATION WITH WATER STANDARD .....	3-2
HI8002EN 2.0 mg/mL TITRANT STANDARDIZATION WITH WATER STANDARD .....	3-4
HI8003EN 1.0 mg/mL TITRANT STANDARDIZATION WITH WATER STANDARD .....	3-6
HI8011EN 5.0 mg/mL TITRANT STANDARDIZATION WITH DISODIUM TARTRATE .....	3-8
HI8101EN MOISTURE DETERMINATION IN DAIRY CREAM .....	3-10
HI8102EN MOISTURE DETERMINATION IN MILK .....	3-12
HI8103EN MOISTURE DETERMINATION IN HONEY .....	3-14
HI8104EN SURFACE MOISTURE DETERMINATION ON WHITE SUGAR .....	3-16
HI8105EN MOISTURE DETERMINATION IN COOKING OIL .....	3-18
HI8106EN MOISTURE DETERMINATION IN BUTTER .....	3-20
HI8107EN MOISTURE DETERMINATION IN MARGARINE .....	3-22
HI8108EN MOISTURE DETERMINATION IN MAYONNAISE .....	3-24
HI8201EN MOISTURE DETERMINATION IN SHAMPOO .....	3-26
HI8202EN MOISTURE DETERMINATION IN HAND CREAM .....	3-28
HI8301EN MOISTURE DETERMINATION IN SOLVENT WITH 5 mg/mL TITRANT (ONE-COMP.) .....	3-30

## PART 4: TITRATION THEORY

1. TITRATION THEORY .....	4-2
1.1. INTRODUCTION TO TITRATIONS .....	4-2
1.2. USES OF TITRATIONS .....	4-2
1.3. ADVANTAGES AND DISADVANTAGES OF TITRATIONS .....	4-2
2. TYPES OF TITRATIONS .....	4-3
2.1. TITRATIONS ACCORDING TO THE MEASUREMENT METHOD .....	4-3
2.2. TITRATIONS ACCORDING TO THE REACTION TYPE .....	4-4
2.3. TITRATIONS ACCORDING TO THE TITRATION SEQUENCE .....	4-11
3. TITRATION PROCEDURE .....	4-12
3.1. MANUAL TITRATION .....	4-12
3.2. AUTOMATIC TITRATION .....	4-12
4. TITRATION RESULTS .....	4-14
4.1. ACCURACY .....	4-14
4.2. REPEATABILITY .....	4-14
4.3. SOURCES OF ERROR .....	4-14
5. CALCULATIONS .....	4-16
5.1. EQUATIONS USED IN VOLUMETRIC KARL FISCHER TITRATIONS .....	4-16
5.2. EQUATIONS USED IN TITRATIONS .....	4-18
6. GLOSSARY .....	4-21

## PART 1:

## QUICK START GUIDE



## 1. SAFETY MEASURES

The following safety measures must be followed:

- 1) Never connect or disconnect the pump assembly or other peripheral with the titrator turned on.
- 2) Verify that the burette and the attached tubing are assembled correctly.
- 3) Always check that the titrant, solvent and waste bottles, as well as the titration beaker are properly assembled.
- 4) Always wipe up spills and splashes immediately.
- 5) Avoid the following environmental working conditions:
  - Severe vibrations
  - Direct sunlight
  - Atmospheric relative humidity above 80% non-condensing
  - Environment temperatures below 10°C and above 40°C
  - Explosion hazards
  - Near heating or cooling sources
- 6) Have the titrator serviced by qualified service personnel only.
- 7) Avoid inhalation of titrant/solvent vapors. Avoid contact with chemicals.

## 2. TITRATOR CONNECTIONS

### 2.1. FRONT VIEW

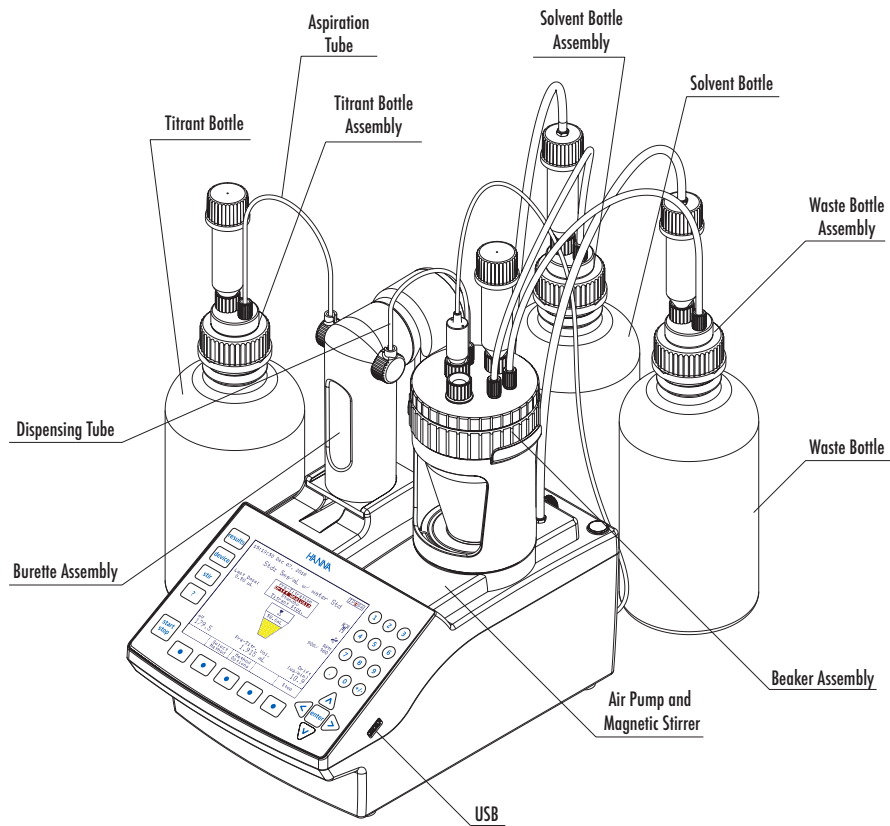

### 2.2. REAR VIEW

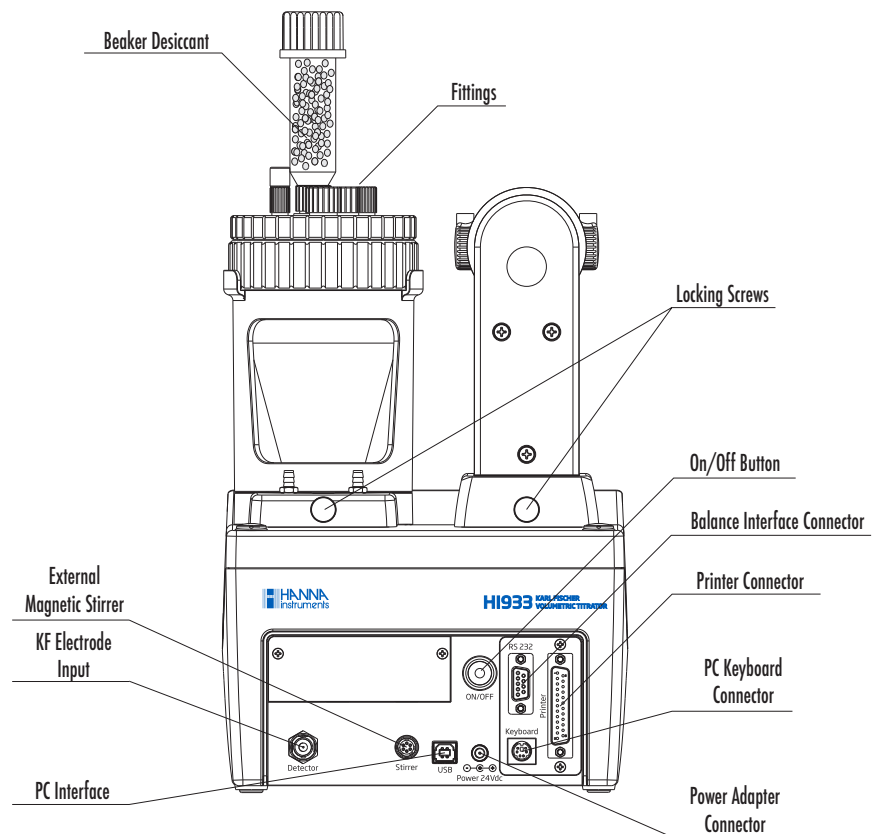

### 3. USER INTERFACE

#### 3.1. KEYPAD

The titrator's keypad has 27 keys grouped in five categories, as follows:

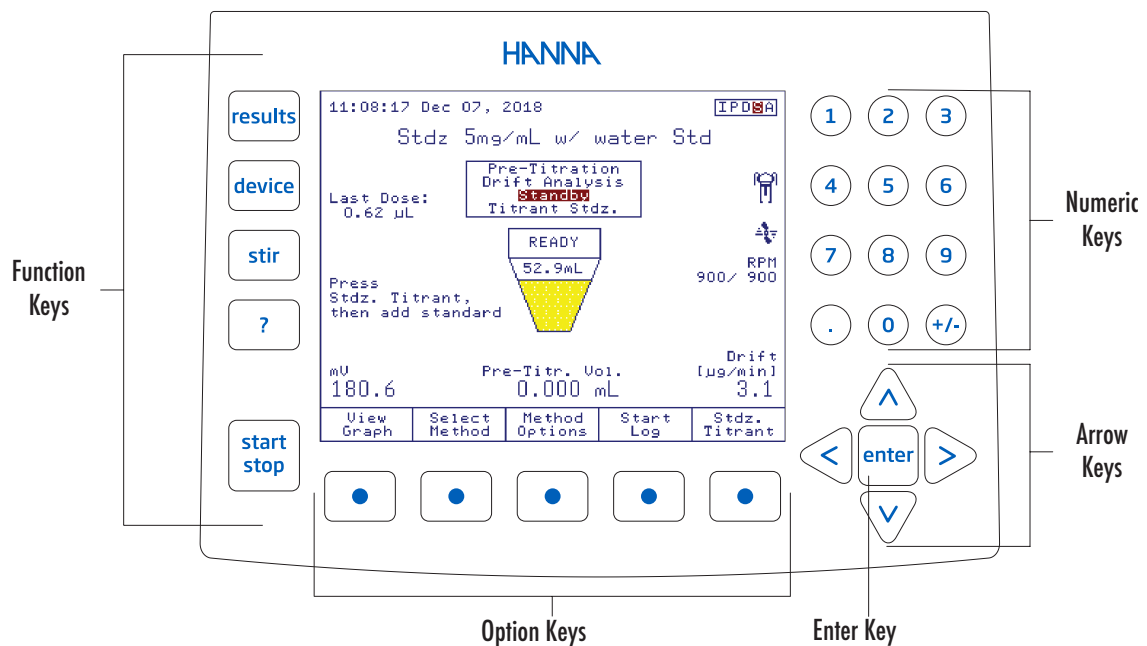

#### 3.2. DISPLAY

The titrator has a 5.7" graphical backlit color display. The **Standby Mode** screen is shown below with short explanations.

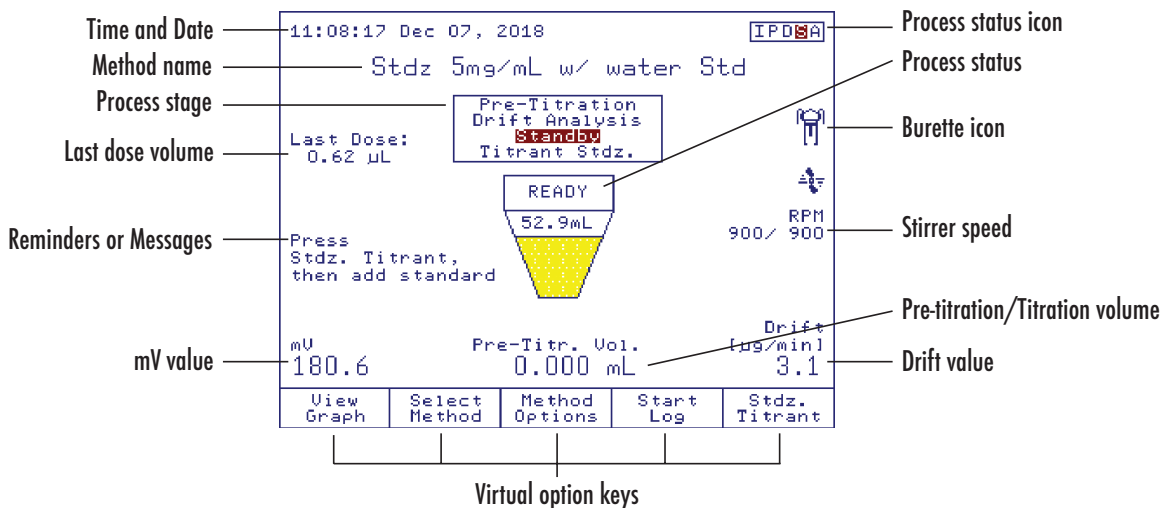

The user interface contains several screens. In each screen, many information fields are present at the same time. The information is displayed in an easy-to-read manner.

Virtual option keys describe the function performed when the corresponding soft key is pressed.

## 4. LANGUAGE

To change the language, press **General Options** from the main screen. Highlight *Language* option. Using the  $\Delta$  and  $\nabla$  keys, select the language from the options listed in the **Set Language** screen and press **Select**. Restart the titrator in order to apply the new language setting.

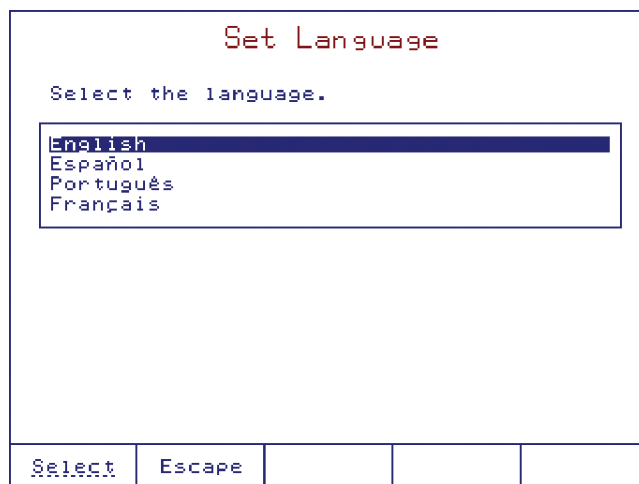

## 5. CONTEXTUAL HELP

Information about the titrator can be easily accessed by pressing **?**. The contextual help can be accessed at any time and it provides useful information about the current screen.

## 6. METHODS

The **HI933** Karl Fischer titrator can store up to 100 methods (standard and user defined).

### 6.1. STANDARD METHODS

Each titrator is supplied with a customized package of standard methods. Standard method packs are developed at Hanna Instruments to meet analysis requirements of specific industries (e.g.: food, cosmetics, dairy, etc.).

### 6.2. USER-DEFINED METHODS

User-defined methods allow the user to create and save their own methods. Each new method is based on an existing method which is altered to suit a specific application.

## 7. PREPARATION

### 7.1. SETTING UP THE TITRATOR

- Make sure that all of the titrator assemblies are properly installed (see [Setup](#) section).
- Make sure that the beaker system is properly sealed against atmospheric moisture (the fittings and tubes are correctly mounted).
- The desiccant has been properly dried.

### 7.2. OBTAINING THE REAGENTS

- The reagents (titrant and solvent) have to be suitable to the analysis requirements (see [Accessories](#) section for list of preferred titrants and solvents).

### 7.3. PRIMING THE BURETTE

- Remove the dispensing tube from titration beaker (unscrew the fitting and remove the tube) and insert it in the waste bottle or separate waste container.
- From the Idle screen press **Burette**.
- Highlight Prime Burette option and then press **Select**.
- Enter the number of burette rinses. At least 3 rinses with the solution used for titration are recommended (allowing air bubbles to be evacuated).
- Press **Accept** to start.
- The message "Executing..." will be displayed.

**Note:** Make sure you have continuous liquid flow inside the burette. Do not use **Stop Burette** during normal filling of the burette if you are not sure that air bubbles have been completely evacuated. For accurate results, the aspiration tube, the dispensing tube and the syringe must be free of air bubbles.

- Carefully wipe the end of the dispensing tube to remove excess titrant.
- Insert the dispensing tube in the corresponding hole of the titration beaker and screw the fitting to seal the beaker.

## 8. THE FIRST TITRATION

### 8.1. METHOD SELECTION

For this analysis we will use the **HI8301EN Solvent w/ 5mg/ml 1-comp** standard method.

To select this method:

- Press **Select Method** from the Idle screen. Use the **▲** and **▼** keys to highlight *HI8301EN Solvent w/ 5mg/ml 1-comp* method.
- Press **Select**.

The method's name will be displayed on the top line of the Idle screen.

### 8.2. SETTING METHOD PARAMETERS

To display the method parameters, press **Method Options**. The **View/Modify Method** screen will be displayed.

Only certain parameters from the standard methods can be changed.

For this titration, only the KF titrant concentration value and the size of the solvent sample need to be entered as in the screen shown below.

To accomplish this:

- Highlight *Titrant* option from the **View/Modify Method** screen and then press **Select**.
- The **Titrant Database** screen will be displayed.
- Highlight *KF Titrant* and press **Edit**.
- Highlight *Standardized Titrant Concentration* and press **Select**.
- Input the correct value, then press **Accept**.
- Press **Escape** three times to return to the Idle screen.

Standardized Titrant Conc.				
Enter the standardized titrant conc.				
5.0000 mg/mL				
Low Limit: 4.0000 mg/mL				
High Limit: 6.0000 mg/mL				
Accept	Escape	Delete Digit		

### 8.3. SETTING UP TITRATION REPORT





Users can select the information that is stored for each titration.

To obtain proper information at the end of the titration, perform the following operations:



- From the main screen, press **results** and the **Data Parameters** screen will be displayed.
- Highlight *Setup Titration Report* option and press **Select**.
- Mark the fields to be included with the \* symbol using the **▲** and **▼** keys, and press **Select** to toggle the selection.
- Press **Save Report** and then press **Escape** to return to the main screen.

## 8.4. FILLING TITRATION BEAKER WITH SOLVENT

The titration beaker must be filled with solvent up to the minimum (MIN) mark (about 50 mL of solvent):



- From the Idle screen, press .
- Press .
- Wait until the beaker is filled up to the minimum (MIN) mark with solvent.
- Stop the air pump by pressing .
- Press  then enter the approximate amount of solvent in the beaker. Press  to confirm.

## 8.5. PREPARING THE SOLVENT FOR SAMPLES

- Before beginning a titration, residual moisture inside the titration beaker and solvent must be reacted.
- From the Idle screen, press . The titrator will enter Pre-Titration mode and begin dosing titrant into the titration beaker. If no titrant can be seen moving through the anti-diffusion tip after several doses, press  or  and verify that no titrant is leaking from the burette housing or from the dispensing tube fittings.
- Once all residual moisture has been reacted (endpoint potential is reached), the titrator will enter Drift Analysis mode (Automatic Drift Entry only). The titrator calculates the rate of atmospheric moisture seeping into the titration beaker for the next minute and displays the result in the lower right corner of the display.
- If the Drift Rate is stable and the endpoint potential is maintained, the titrator will enter Standby mode. The titrator continues to maintain the endpoint potential and update the background drift rate.

## 8.6. PREPARING AND INTRODUCING THE SAMPLE

Measuring the sample size by mass and using an analytical balance will give the most reproducible results.

- Prepare 50 mL of sample by mixing equal parts of dry chloroform and dry methanol.
- Fill the syringe and needle with the sample.
- Weigh the syringe, needle and sample.
- Press . You will be prompted to enter the sample size.
- Dispense 0.750 g to 1.000 g of solvent into the titration vessel through the septum using the needle.
- Remove the needle from the titration vessel and weigh the syringe again in order to determine the added sample mass (by difference of the two measurements.)
- Use the numeric keypad to enter the exact weight and press  to start the analysis.



## 8.7. PERFORMING A TITRATION

- Add a prepared sample according to one of the preparation methods outlined above. Enter the analyte size and press **Sample Analysis**. The titrator will start the analysis according to the selected method.
- At the end of the titration, the message "Titration Completed" will appear on the titration status, together with the final concentration of the moisture in the sample, the end point volume, and other relevant information. The titrator re-enters Standby mode in the background.

Sample Analysis Result <span style="float: right;">IPD SA</span>			
<b>2059.4</b> ppm			
<b>Titration Completed</b>			
Analysis Duration:	05:54 [mm:ss]		
Drift Value:	1.2 µg/min		
Sample Size:	0.2145 g		
Standardized Titrant Conc.:	1.0002 mg/mL		
Volume Delivered:	0.443 mL		
Report ID:	KF_00047		
Escape	View Report	Average Results	

## 8.8. UNDERSTANDING THE DISPLAYED INFORMATION

During a titration, the following screen is displayed:

11:47:59 Jan 07, 2019 <span style="float: right;">IPD SA</span>			
Moisture in Cooking Oil			
Last Dose: 0.00 µL		<div style="border: 1px solid black; padding: 2px; display: inline-block;">           Pre-Titration Drift Analysis  <b>Standby</b>            Sample Analysis         </div>	
Press Sample Analysis, then add sample		<div style="border: 1px solid black; padding: 2px; display: inline-block;">           READY            51.5mL         </div>	
		  RPM 900/ 900	
mU 179.5	Pre-Titr. Vol. 0.002 mL	Drift [µg/min] 0.0	
View Graph	Select Method	Method Options	Start Log
Sample Analysis			

## 8.9. VIEWING GRAPH DURING TITRATION

Press  to display the real time titration graph.

The curve displayed is a plot of Electrode Potential vs. Titrant Volume.

A dashed horizontal line represents the user selected end point potential.

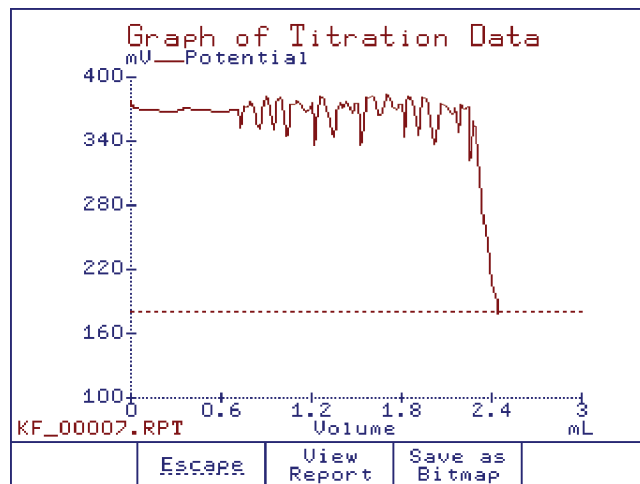

**Note:** For fresh solvents, especially one-component solvents, the first few titration graphs may look very noisy. This is because the reaction with the titrant is sluggish if there is a low amount of excess Karl Fischer reagent (sulfur dioxide and base) in the titration vessel. After several titrations, the reaction speed and graph should improve.

## 8.10. TITRATION TERMINATION

The titration is terminated when the conditions of the Termination Criteria have been met.

The default Termination Criterion is a mV value, in which the titration is terminated after the mV value remains below the end point potential for the selected stability time.

When the titration has ended, the titrator will display the final concentration of the moisture together with the basic titration information.

To view the custom report or titration graph, press .

To view statistics of multiple analyses, press .

For titrant standardizations, press  to update the active titrant with the displayed standardization result.

When done, press  to return to standby mode (if active).

## 8.11. RESULTS

The results obtained from titration are stored in a report file that can be displayed, transferred to a USB storage device or a PC, or printed.

Review Result			
KF_00011.RPT			
HI933 - Titration Report			
Method Name:	copy of Moisture in Milk		
Time & Date:	15:18 Jan 21, 2019		
Titration ID:	KF_00011		
Nr	Volume[m1]	mV	Time
0	0.0000	391.6	00:00:00
1	0.0000	391.1	00:00:01
2	0.0005	391.0	00:00:03
3	0.0010	391.1	00:00:05
4	0.0015	391.0	00:00:07
5	0.0020	391.0	00:00:09

View Graph    Escape    Print Report    Page Up    Page Down

## 8.12. VIEWING THE LAST TITRATION DATA

- From the main screen, press **results**. The **Data Parameters** screen will be displayed.
- From the **Data Parameters** screen highlight *Review Last Report* option and press **Select**. The **Review Result** screen will be displayed.
- Use the **Page Up** and **Page Down** keys to display information related to the last titration performed.

See Titration Report on next page.

## 8.13. PRINTING THE TITRATION REPORT

Connect a DOS / Windows-compatible parallel printer directly to the DB 25 pin connector located on the back of the titrator.

**Note:** Prior to connecting the printer, ensure that the titrator and the printer have been turned off.







Printing out the report:

- From the **Review Report** screen, press **Print Report**.
- During the information transfer to the printer, the message "Printing" will be displayed on the screen.
- Press **Escape** to return to the **Data Parameters** screen.
- Press **Escape** again to return to the main screen.





## 8.14. SAVING DATA TO USB STORAGE DEVICE

**Note:** The USB Storage Device has to be formatted FAT or FAT32.

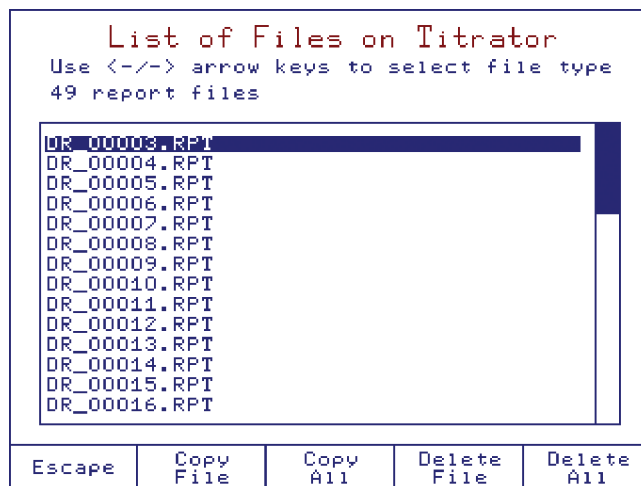
This feature allows saving the results of titrations or drift logging sessions on a USB storage device.

- From the main screen, press  the **General Options** screen will be displayed.
- Highlight *Save Files to USB Storage Device* option using the  and  keys.
- Insert the USB storage device into the USB socket.
- Press , the **List of Files on Titrator** screen will be displayed.
- Use the  and  keys to select the report files.



- Press  to transfer all available reports to the USB storage device, or highlight the name of the report file to be transferred and press .
- Transferring a report file will automatically transfer the corresponding log file and titration graph (\*.BMP file if applicable).
- Press  to return to the **General Options** screen.
- Press  again to return to the main screen.

## 8.15. TITRATION REPORT

While scrolling with the  and  keys, the fields below can be seen on the titrator display or printed. The same information is available on the saved report file (KF\_00003.rpt in this example, with all report fields selected).

### HI933 - Titration Report

Method Name: Moisture in brake fluid  
 Time & Date: 16:59 Dec 19, 2018  
 Titration ID: KF\_00010

Nr	Volume [ml]	mV	Time
0	0.0000	685.5	00:00:00
1	0.3261	685.0	00:00:02
2	0.3276	684.9	00:00:04
3	0.3306	684.1	00:00:06
4	0.3366	683.7	00:00:08
5	0.3486	682.7	00:00:10
6	0.3726	681.7	00:00:12
7	0.4126	678.0	00:00:15
8	0.4526	675.5	00:00:17
9	0.4926	673.0	00:00:19
10	0.5326	671.6	00:00:21
11	0.5726	669.6	00:00:23
12	0.6126	667.6	00:00:25
13	0.6526	666.7	00:00:27
14	0.6926	665.9	00:00:29
15	0.7326	665.0	00:00:31
16	0.7726	659.2	00:00:33
17	0.8126	654.9	00:00:35
18	0.8526	654.1	00:00:37
19	0.8926	649.6	00:00:39
20	0.9326	646.7	00:00:41
21	0.9726	635.8	00:00:43
22	1.0126	633.9	00:00:45
23	1.0526	622.4	00:00:47
24	1.0926	615.2	00:00:49
25	1.1326	587.8	00:00:51
26	1.1726	584.5	00:00:53
27	1.2126	550.1	00:00:55
28	1.2526	524.0	00:00:57
29	1.2926	452.3	00:00:59
30	1.3300	405.6	00:01:01
31	1.3671	290.6	00:01:03
32	1.3856	227.5	00:01:05
33	1.3949	197.5	00:01:07
34	1.3995	183.4	00:01:09
35	1.4017	187.7	00:01:11
36	1.4062	177.3	00:01:14
37	1.4062	184.0	00:01:16
38	1.4077	178.8	00:01:18

39	1.4077	174.7	00:01:20
40	1.4077	180.2	00:01:22
41	1.4077	174.7	00:01:24
42	1.4077	175.8	00:01:26
43	1.4077	179.3	00:01:28
44	1.4077	186.2	00:01:30
45	1.4092	182.1	00:01:32
46	1.4107	177.5	00:01:34
47	1.4107	174.2	00:01:36
48	1.4107	177.0	00:01:38
49	1.4107	183.3	00:01:40
50	1.4122	174.0	00:01:42
51	1.4122	175.3	00:01:44
52	1.4122	175.9	00:01:46
53	1.4122	181.6	00:01:48
54	1.4122	181.9	00:01:50
55	1.4137	185.7	00:01:52
56	1.4167	174.6	00:01:54
57	1.4167	170.3	00:01:56
58	1.4167	173.4	00:01:58
59	1.4167	174.6	00:02:00
60	1.4167	174.5	00:02:02
61	1.4167	177.2	00:02:04
62	1.4167	188.1	00:02:06
63	1.4182	179.7	00:02:08
64	1.4182	176.2	00:02:10
65	1.4182	185.7	00:02:12
66	1.4197	179.6	00:02:14
67	1.4197	175.7	00:02:17
68	1.4197	184.0	00:02:19
69	1.4212	169.9	00:02:21
70	1.4212	178.2	00:02:23

#### Titration Results

Method Name: Moisture in brake fluid  
 Time & Date 16:59 Dec 19, 2018  
 Sample Size: 0.6585 g  
 Std. Titrant Conc.: 1.1608 mg/mL  
 Drift Value: 15.2 µg/min  
 End Point Volume: 1.421 mL  
 Result: 0.2429 %  
 Titration Duration: 03:18 [mm:ss]  
 Estimated Cell Volume: 69.9 mL  
 Titration went to Completion  
 Operator Name:  
 Analyst Signature: \_\_\_\_\_



## 1. SETUP

### 1.1. UNPACKING

Remove the titrator and accessories from the packaging and examine it carefully to make sure that no damage has occurred during shipping. Notify your nearest Hanna Service Center if damage is observed.

Each HI933 titrator is supplied with:

ITEM	QUANTITY
Titrator .....	1 pc
Dosing Pump Assembly .....	1 pc
Burette Assembly.....	1 pc
• Burette (with 5 mL syringe)	
• Aspiration Tube with Fitting and Protection Tube	
• Dispensing Tube with Fitting and Protection Tube	
• Tube Locks	
• Tool for Burette Cap Removal	
• Light Protection Screen	
Air Pump and Magnetic Stirrer Assembly.....	1 pc
Beaker Assembly .....	1 pc
• Glass Beaker	
• Anti-diffusion Glass Dispensing Tip	
• Beaker Ring	
• Beaker Cap	
• Stir Bar	
• Desiccant	
• Desiccant Cartridge	
• Fittings	
• O-rings	
Beaker Support .....	1 pc
Pump Locking Screws with Plastic Head.....	2 pcs
Titrant Bottle Assembly.....	1 pc
• Bottle Cap	
• Desiccant	
• Desiccant Cartridge	
• Fittings	
• O-rings	
Solvent Bottle Assembly .....	1 pc
• Bottle Cap	
• Desiccant	
• Desiccant Cartridge	
• Fittings	
• O-rings	
• Tubes (Silicone and PTFE Tubing)	

Waste Bottle Assembly .....	1 pc
• Bottle Cap	
• Desiccant	
• Desiccant Cartridge	
• Fittings	
• O-rings	
• Tubes (Silicone and PTFE Tubing)	
Karl Fischer Dual Platinum Pin Electrode .....	1 pc
Calibration Key .....	1 pc
Power Supply .....	1 pc
USB Cable .....	1 pc
Instruction Manual .....	1 pc
USB Storage Device .....	1 pc
Quality Certificate .....	1 pc
ISO 8655 Burette Compliance Report .....	1 pc

See [Accessories](#) section for pictures.

If any of the items are missing or damaged, please contact your sales representative.

**Note:** *Save all packing materials until you are sure that the instrument functions correctly. Any damaged or defective items must be returned in their original packing materials together with the supplied accessories.*

## 1.2. SAFETY MEASURES

The following safety measures must be followed:

- 1) Never connect or disconnect the dosing pump or air pump and magnetic stirrer assemblies with the titrator turned on.
- 2) Verify that the burette and the attached tubing are assembled correctly (see [Maintenance](#), [Peripherals](#), [Burette Maintenance](#) for more details).
- 3) Always check that the titrant, solvent, waste bottles and the titration beaker are properly assembled.
- 4) Always wipe up spills and splashes immediately.
- 5) Avoid the following environmental working conditions:
  - Severe vibrations
  - Direct sunlight
  - Atmospheric relative humidity above 80% non-condensing
  - Environment temperatures below 10°C and above 40°C
  - Explosion hazards
- 6) Have the titrator serviced only by qualified service personnel.

## 1.3. TECHNICAL SPECIFICATIONS

Measurement	Range	100 ppm to 100%
	Resolution	1 ppm to 0.0001%
	Result Units	%, ppm, mg/g, $\mu\text{g/g}$ , mg, $\mu\text{g}$ , mg/mL, $\mu\text{g/mL}$ , mg/pc, $\mu\text{g/pc}$
	Sample Type	Liquid or Solid
Determination	Pre-Titration Conditioning	Automatic
	Background Drift Correction	Automatic or User Selectable Value
	Endpoint Criteria	Fixed mV persistence, Relative drift stop or Absolute drift stop
	Dosing	Dynamic with optional pre-dispensing
	Result Statistics	Mean, Standard Deviation
Titration System	Dosing Pump Resolution	1/40000 of the burette volume (0.125 $\mu\text{L}$ per dose)
	Dosing Pump Accuracy	$\pm 0.1\%$ of full burette volume
	Syringe	5 mL precision ground with PTFE plunger
	Valve	Motor-driven 3-way, PTFE liquid contact material
	Tubing	PTFE with light block and thermal jacketing
	Dispensing Tip	Glass, fixed position anti-diffusion
	Titration Vessel	Conical with operating volume between 50-150 mL
Electrode	Solvent Handling System	Sealed system, integrated diaphragm air pump
	Type	Dual platinum pin, polarization electrode
	Connection	BNC
	Polarization Current	1, 2, 5, 10, 15, 20, 30 or 40 $\mu\text{A}$
	Voltage Range	2 mV to 1000 mV
	Voltage Resolution	0.1 mV
Stirrer	Accuracy	$\pm 0.1\%$
	Type	Magnetic, electronic regulated, digital stirrer
	Speed	200 to 2000 RPM
Storage	Resolution	100 RPM
	Methods	Up to 100 (standard and user defined) methods
Peripheral Devices	Reports	Up to 100 complete titration reports and drift rate reports
	PC Connection	1 x USB Standard B
	USB flash drive	1 x USB Standard A
	Analytical Balance	1 x DB-9 Socket
	Printer	1 x DB-25 Socket
	External PC Keyboard	1 x 6-pin Mini DIN

Additional Specifications	Display	5.7" graphical color display with backlight
	Languages	English, Portuguese, Spanish, French
	Power Supply	100-240 Vac, 50/60 Hz
	Power Draw	0.5 Amps
	Enclosure Material	ABS, PC and Stainless Steel
	Keypad	Polyester
	Dimensions	315 x 205 x 375 mm (12.4 x 8.1 x 14.8 ")
	Weight	approx. 4.3 kg (9.5 lbs.) with 1 pump, stirrer and sensors
	Operating Environment	10 to 40 °C (50 to 104 °F); up to 80 % RH
	Storage Environment	-20 to 70 °C (-4 to 158 °F); up to 95 % RH

## 1.4. INSTALLATION

### 1.4.1. TITRATOR RIGHT VIEW

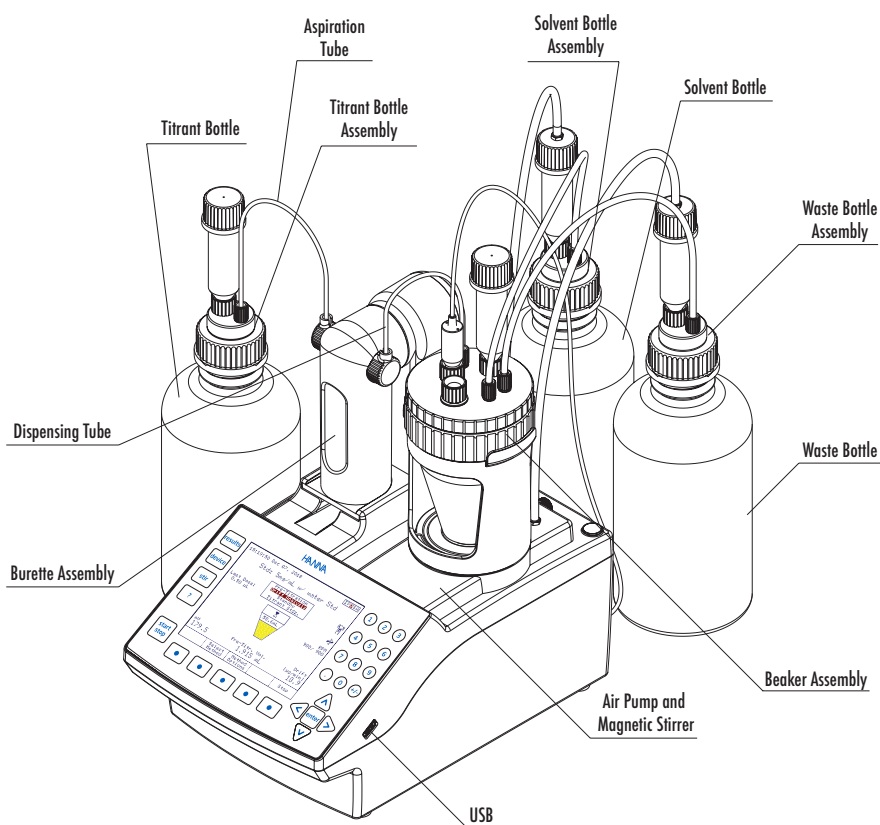

## 1.4.2. TITRATOR REAR VIEW

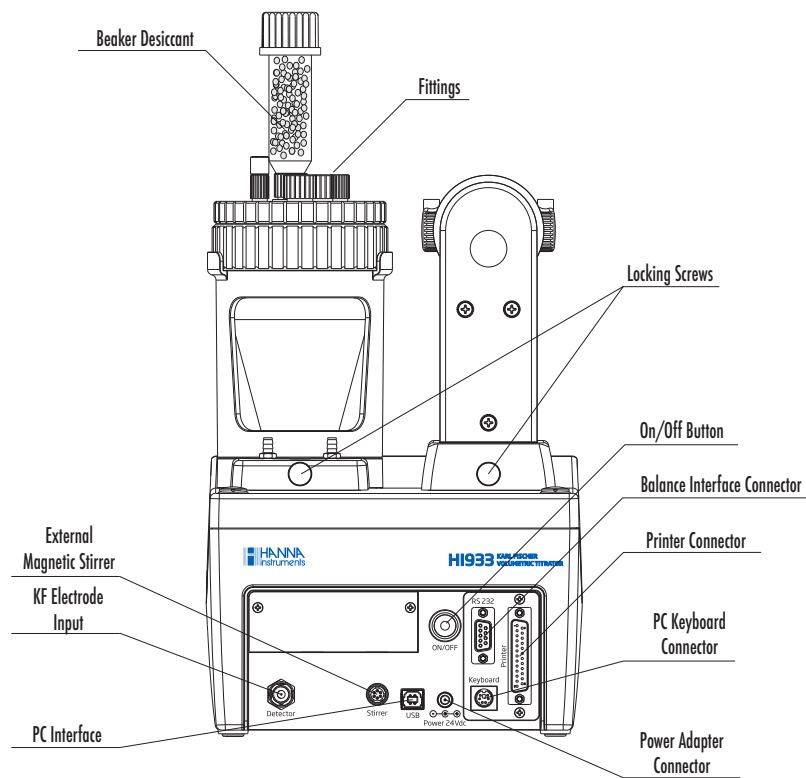

## 1.4.3. TITRATOR LEFT VIEW

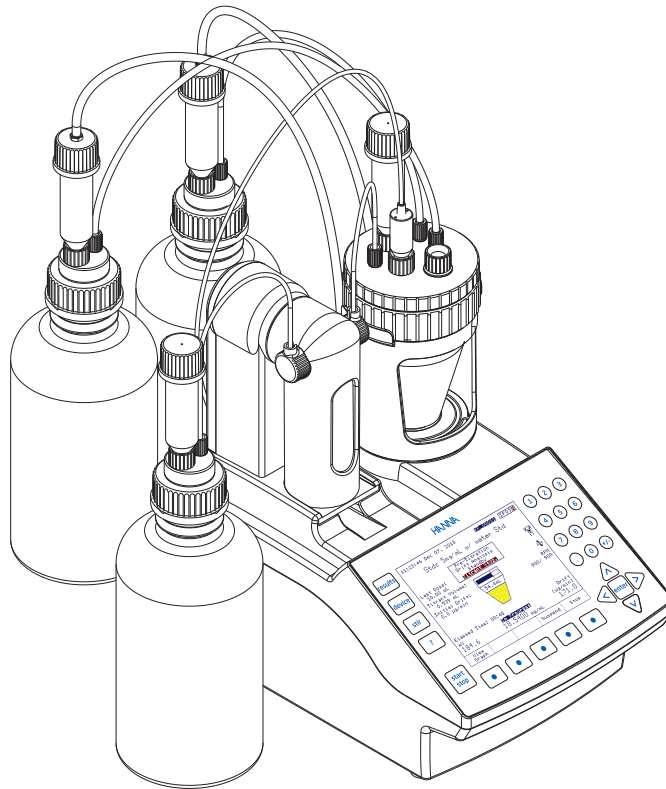

## 1.4.4. TITRATOR ASSEMBLY

**Note:** Assembly operations must be completed before connecting the titrator to the power supply!

### 1.4.4.1. CONNECTING THE PUMP

To connect the dosing pump, follow these steps:

- Retrieve the pump cable from inside the left bay.
- Connect the cable to the pump as shown below (A). The pump connector is located on the bottom of the pump.
- Lower the pump into the titrator (B), then slide it towards the front of the titrator case until it is firmly latched.
- Secure the pump with the locking screw (C).

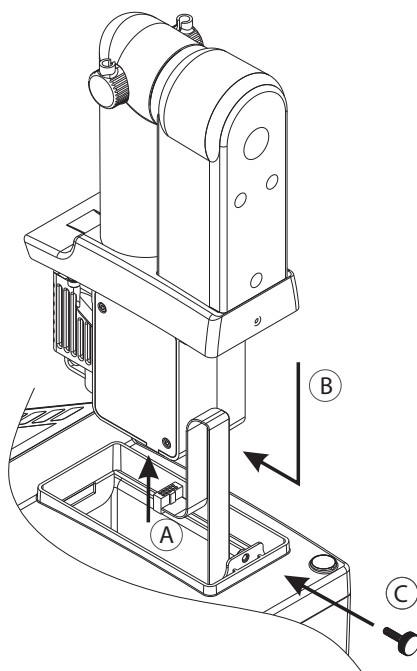

### 1.4.4.2. CONNECTING THE AIR PUMP AND MAGNETIC STIRRER

To connect the air pump and magnetic stirrer, follow these steps:

- Retrieve the air pump cable from inside the right bay.
- Connect the cable to the air pump as shown below (A). The air pump and magnetic stirrer is located on the bottom of the assembly.
- Lower the pump into the titrator (B), then slide it towards the front of the titrator case until it is firmly latched.
- Secure the pump with the locking screw (C).

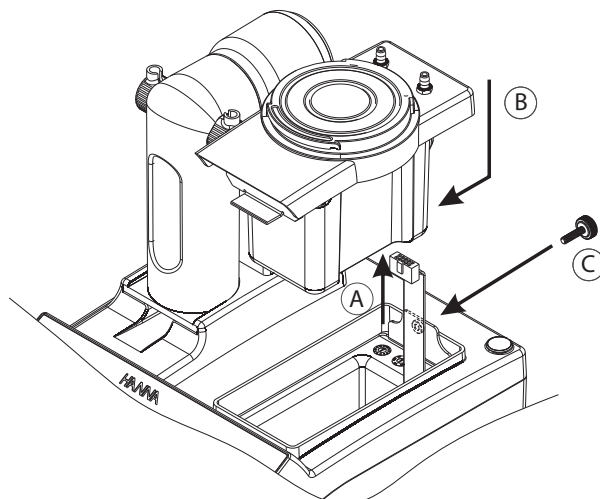

### 1.4.4.3. ATTACHING THE BURETTE

Make sure that the mark from the valve actuating cap and the burette body are aligned as shown below.

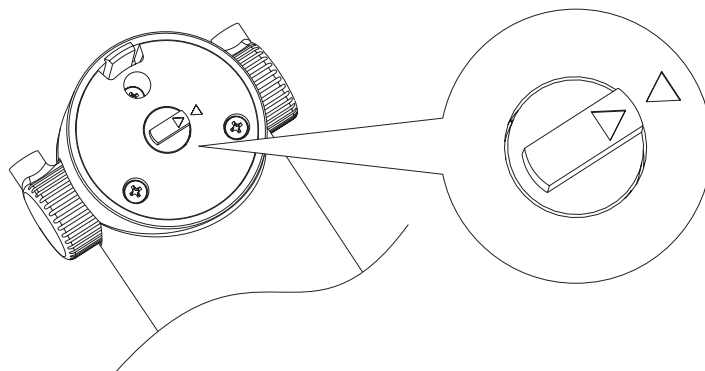

While ensuring the correct coupling between the syringe plunger (A) and the pump piston (B), slide the burette into the support on the burette pump.

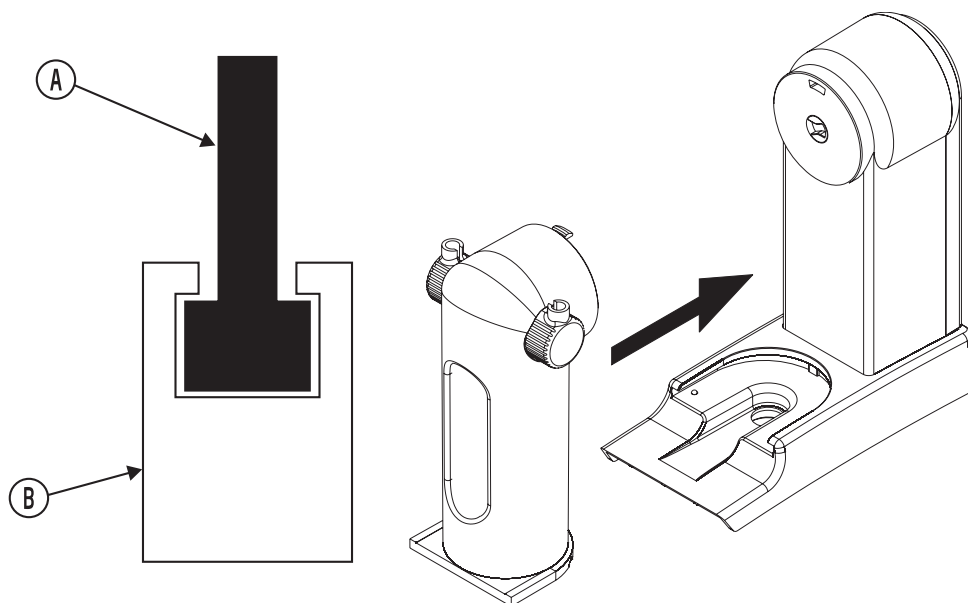

#### 1.4.4.4. ASSEMBLING THE BEAKER

To attach the beaker assembly follow the steps below:

- Align the beaker support (D) with the base plate and attach by rotating clockwise.
- Place beaker ring (C) onto beaker support (D) with the notches on top.
- Insert the glass beaker (B) into the beaker ring (C).
- Add the stir bar to the glass beaker (B).
- Carefully place the beaker top (A) onto the beaker (B). Secure in place by pushing the beaker top through the beaker ring (C) with the 4 notches of the beaker ring aligned with the 4 steel pins of the beaker top.
- Twist the beaker ring (C) counter-clockwise to lock the top in place.

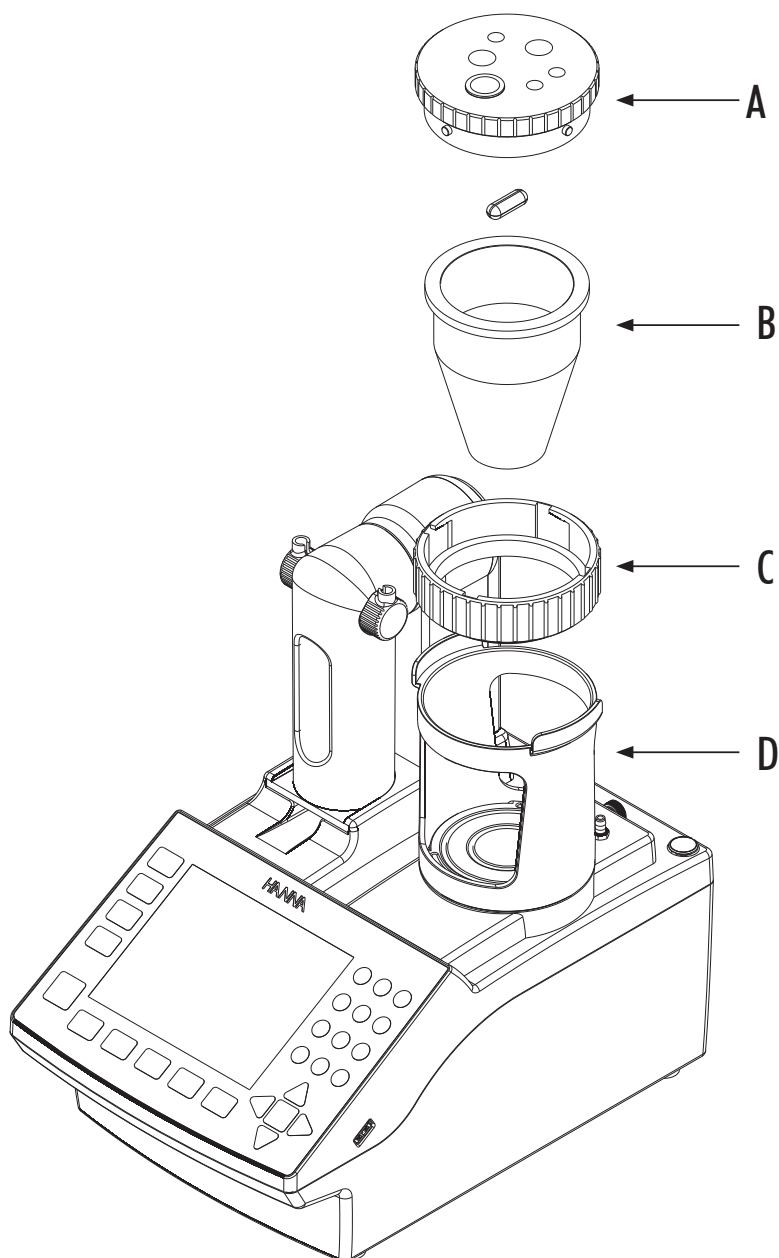

#### 1.4.4.5. BEAKER TOP

**Warning!** Do not overtighten fittings! This may cause permanent damage to o-rings and beaker top!

To assemble the beaker top follow the steps below:

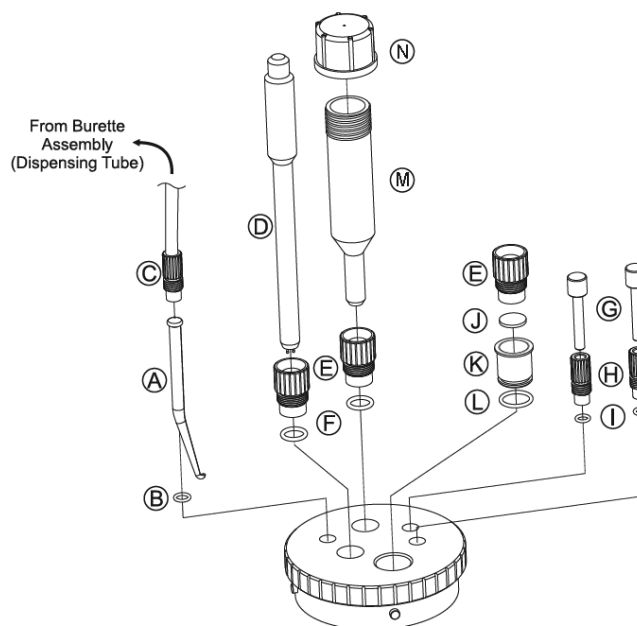

##### 1.4.4.5.1. ANTI-DIFFUSION DISPENSING TIP AND DISPENSING TUBE

To install the anti-diffusion tip and dispensing tube follow the steps below:

- Push dispensing tip (A) through the dispensing tip o-ring (B) until the o-ring is at the lip of the dispensing tip. Insert the tip through the proper port (the HI933 ships with the dispensing tip and o-ring installed).
- Position the tip so that the angled portion is directed toward the center of the assembly.
- Fasten the dispensing tube (C) from the burette assembly to the dispensing tip port using the fitting. Ensure that the tip remains oriented toward the center of the beaker.

##### 1.4.4.5.2. KARL FISCHER ELECTRODE

To install the Karl Fischer electrode in the beaker top follow the steps below:

- Carefully insert the electrode (D) through a 10-mm fitting (E) and 10-mm o-ring (F).
- Insert electrode through proper port in beaker top.
- Align the pins to the center of the beaker, fasten the 10-mm fitting (E) to the beaker top. The electrode should be as far down into the beaker as possible without touching the stir bar.

##### 1.4.4.5.3. SOLVENT HANDLING SYSTEM

To attach solvent bottle tubing or waste bottle tubing, follow the steps below:

- Loosen the 5-mm fitting (H) on the solvent and/or waste port.
- Remove the desired plug or plugs (G).
- Insert the blue PTFE tubing from the solvent and/or waste bottle assemblies through the 5-mm fittings (H) and o-rings (I) until about 1 cm of tubing is visible inside the beaker.
- Tighten the 5-mm fittings (H) until snug. This will cause the o-rings (I) to seal around the tubes.

#### 1.4.4.5.4. SAMPLE PORT PLUG

The **HI933** is delivered with the sample port plug assembled and installed. To replace the rubber septum, follow the steps below:

- Insert a red rubber septum (J) into the septum holder (K).
- Secure the septum with a 10-mm fitting (E).
- Place the sample port plug o-ring (L) on the bottom of the septum holder (K).
- Insert the assembled sample port plug into the dedicated port of the beaker top.

#### 1.4.4.5.5. DESICCANT CARTRIDGE

- Insert the stem of a desiccant cartridge (M) without hose-barbed cap (N) through a 10-mm fitting (E) and 10-mm o-ring (F).
- Insert in the proper port of the beaker top.
- Fasten to the beaker top with the 10-mm fitting.

#### 1.4.4.5.6. ELECTRICAL CONNECTIONS

- Connect the KF electrode to the BNC connector (A).
- Connect the power adapter cable to the power input connector (D).

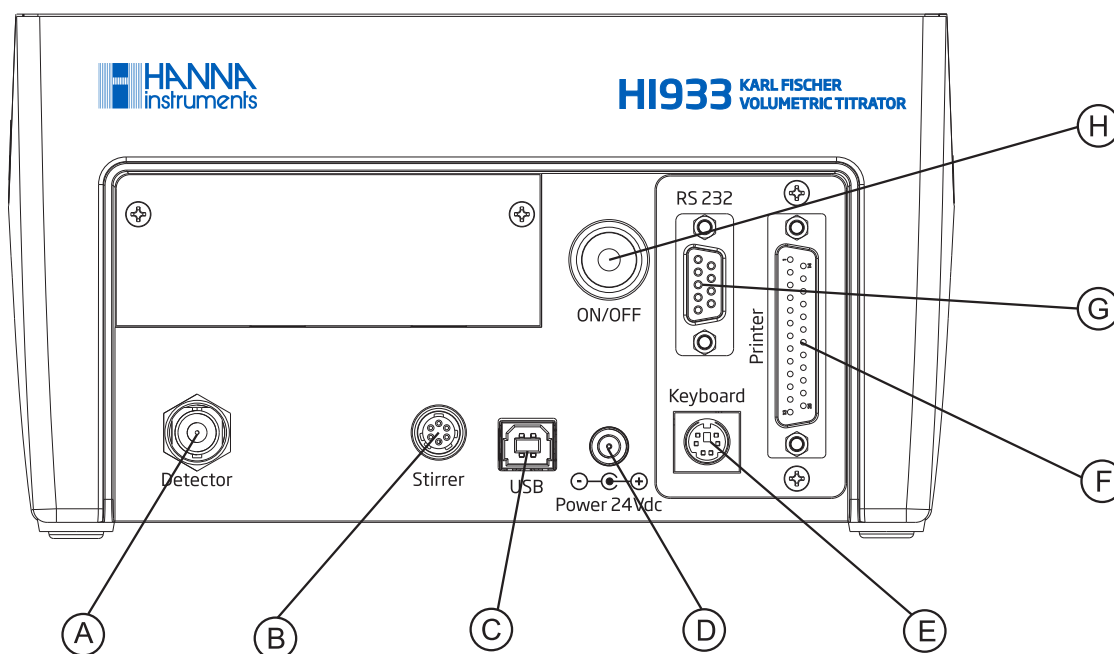

	Function	Type of Connector
A	Detector	BNC socket
B	Stirrer	6-pin Connector
C	USB interface	USB Standard B
D	Power input connector (24VDC)	DC Power Jack connector
E	External PC keyboard	6-pin Mini Din (Standard PS2)
F	Printer	DB-25 Socket
G	RS232 interface (Balance Interface)	DB-9 Socket
H	Power switch	

#### 1.4.4.6. TITRANT, SOLVENT, WASTE BOTTLE ASSEMBLY

The bottle top assemblies are equipped with desiccant cartridges containing indicating silica gel which ensures that the air passing through the solvent handling system has been dried.

*The desiccant has a limited capacity to absorb moisture and is typically exhausted after 2 to 4 weeks. Silica gel, indicating or otherwise, can be regenerated at 150°C.*

The bottle tops are made of PTFE and have been designed to accommodate reagent bottles with GL-45 type threaded tops.

The waste and solvent bottle top assemblies include blue PTFE tubing for the handling of liquid Karl Fischer solvent and a clear flexible silicone based tubing for use with the air pump.

##### 1.4.4.6.1. TITRANT BOTTLE ASSEMBLY (HI900530)

**Caution:** Most Karl Fischer titrants give off harmful vapors. Consult manufacturer's MSDS for safe handling guidelines.

To assemble the titrant bottle, follow the steps below:

- Insert PTFE top (J) into a GL45 screw cap (E).
- Insert a desiccant cartridge (B) without hose-barbed cap (A) through a 10-mm fitting (F) and 10-mm o-ring (G).
- Insert and screw the desiccant cartridge assembly into the corresponding hole in the white PTFE top (J). Fasten with 10-mm fitting (F).
- Ensure that the tube protector (C) is installed on the aspiration tubing (D).
- Insert the burette aspiration tubing (D) in the corresponding 3-mm fitting (H) and attach the 3-mm o-ring (I).
- Insert and screw the aspiration tube fitting into the corresponding hole in the cap.
- Push the aspiration tubing fully into the titrant bottle until only the tube protector (C) is visible outside of the titrant bottle (K).
- Screw GL45 cap (E) with full assembly onto the titrant bottle (K).

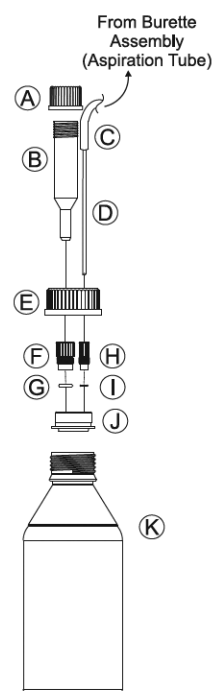

##### 1.4.4.6.2. SOLVENT AND WASTE BOTTLE ASSEMBLY (HI900531)

**Caution:** Most Karl Fischer solvents give off harmful vapors. Consult manufacturer's MSDS for safe handling guidelines.

To assemble the solvent or waste bottle, follow the steps below:

- Insert a PTFE top (J) into a GL45 cap (E).
- Screw on the desiccant cap with screw hose barb (A).
- Insert a desiccant cartridge (B) with hose-barbed cap (A) through a 10-mm fitting (F) and 10-mm o-ring (G).
- Insert and screw the desiccant fitting into the corresponding hole. Fasten the desiccant cartridge assembly to PTFE top (J) with 10-mm fitting (F).
- Insert the solvent / waste tube (D) in the 5-mm fitting (H) and attach the o-ring (I).
- Insert and screw the tube fitting into the corresponding hole in the cap.
- Screw GL45 (E) cap with full assembly onto titrant bottle (K).
- Add the air tube (C) to the desiccant cap (A) and connect it to the corresponding position on the air pump. The "Fill" position connects to the solvent bottle assembly. The "Empty" position connects to the waste bottle assembly.

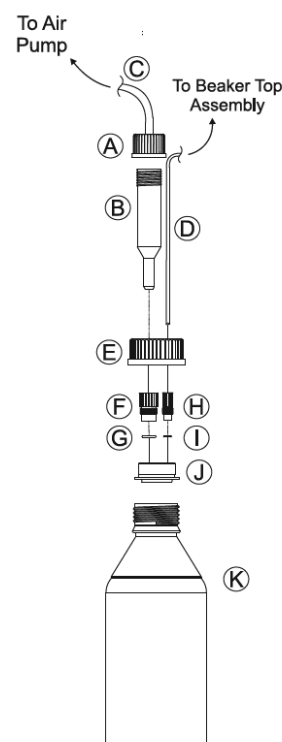

## 2. USER INTERFACE

### 2.1. START UP

Once the instrument is assembled and installed, follow the steps below to start the titrator:

- Connect the titrator to a power outlet with the supplied power adapter.
- Turn on the titrator from the power switch located on the back of the instrument.
- Wait until the titrator finishes the initialization process.
- Press  when prompted or wait a few seconds for titrator to start.

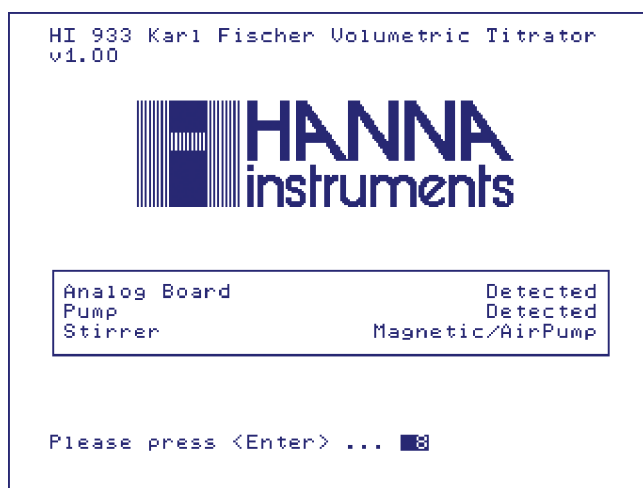

**Note:** All the performed initialization processes must be successfully completed. If one of the initialization processes fails, restart the titrator. If the problem persists contact your nearest Hanna Instruments Service Center.



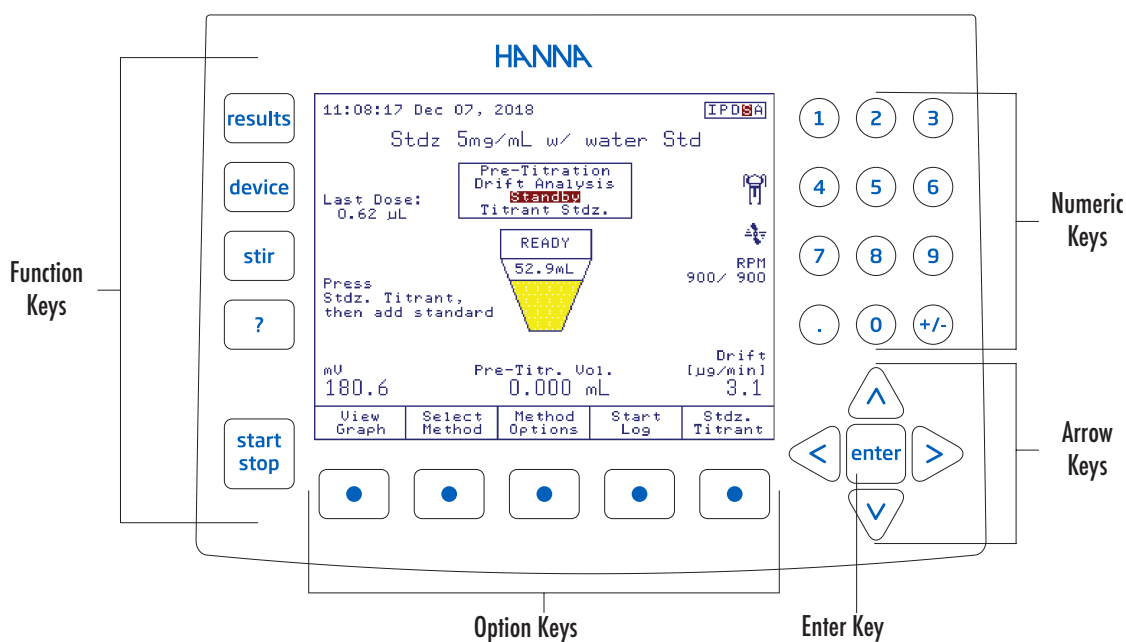

### 2.2. KEYPAD

The titrator's keypad is grouped into five categories, as follows:



### 2.2.1. FUNCTION KEYS

If one of these keys is pressed, the associated function is immediately performed. Some of the keys are active only in specific screens:

-  Starts or Stops a titration process
-  Turns the selected stirrer On and Off
-  Reserved
-  Access the Data Parameters Menu (reports, GLP, meter information, report setup)
-  Displays Contextual Help

### 2.2.2. OPTION KEYS

These keys are assigned to the virtual keys on the display. Their functions are listed in the boxes above the buttons and vary depending on the displayed screen.

An underlined virtual key can also be activated by pressing .

### 2.2.3. ARROW KEYS

These keys have the following functions:

- Move the on-screen cursor.
- Increase and decrease the stirrer speed and other settings.
- Select a character (alphanumeric screen only).
- Navigate through menu options.

### 2.2.4. NUMERIC KEYS

Keys  to  Used for numeric entries.

 Toggles between positive and negative values.

 Used for decimal point.

### 2.2.5. ENTER KEY

This key has the following functions:

- Accepts alphanumeric data entry.
- Executes the default (underlined) virtual option key.

## 2.3. DISPLAY

The titrator has a large color graphical display. The main screen is shown below with short explanations of the screen segments.

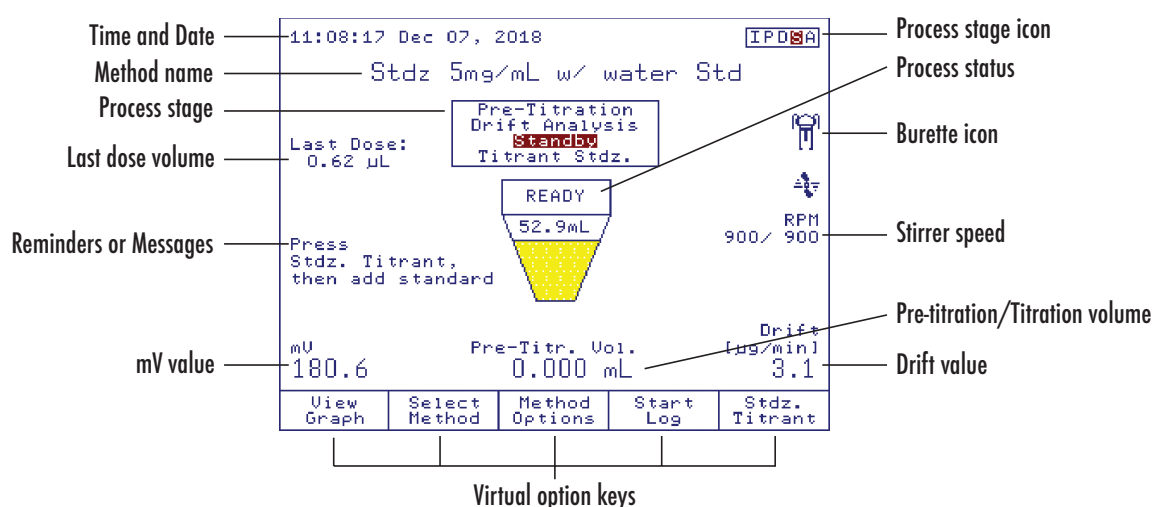

The user interface contains several screens. For each titrator function, several screens may be used.

### 2.3.1. THE IDLE SCREEN

After start up and initialization, the first screen displayed is the Idle screen.

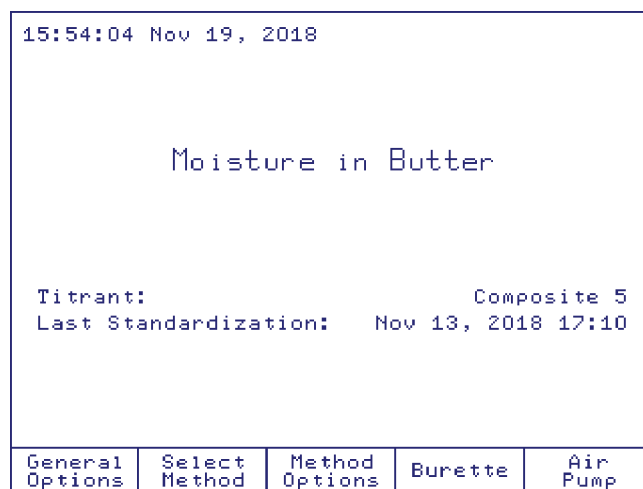

Idle screen fields:

- Method name:** Displays the name of the selected method.
- Time and date:** Displays the current date and time.
- Stirrer information:** Actual / Set stirrer speed is displayed in RPM. When stirrer is off, the stirrer information is not displayed.
- Titration:** Displays the name of the current titrant.
- Last Standardization:** Displays the titrant standardization date and time.
- Reminders:** Indicates when a task needs to be performed and displays error or warning messages.

### 2.3.2. THE PROCESS SCREEN

When the user presses  while in Idle, all titration related processes are started. The titrator displays the **Process** screen.

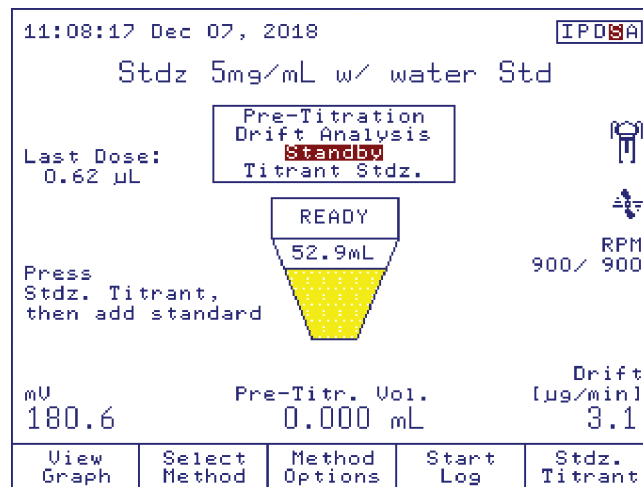

Process screen fields:

- Method name:** Displays the name of the selected method.
- Time and date:** Displays the current date and time.
- Process stage field:** Displays the current process (Pre-titration, Drift Analysis, Standby, Sample Analysis / Titrant Standardization).
- Process status:** Displays the process status with a descriptive drawing.
- mV reading:** Displays the KF electrode potential.
- Dispensed titrant:** Displays the total volume of dispensed titrant.
- Last dose:** Displays the last titrant dose volume.
- Drift value:** Displays the drift value (when available).
- Stirrer information:** Actual / Set stirrer speed is displayed in RPM.
- Burette status:** A descriptive drawing is displayed indicating the burette is active and cannot be removed.
- Reminders:** Indicates when a task needs to be performed and displays error or warning messages.

## 2.4. MENU NAVIGATION

### 2.4.1. SELECTING AN OPTION

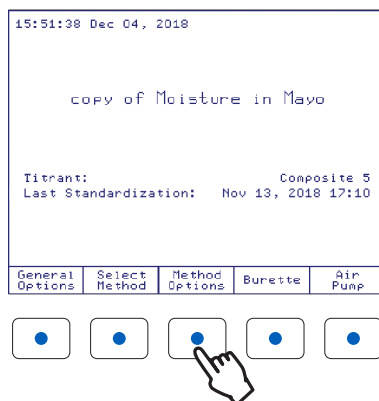

To select an option, press the option key below the virtual key. For example, to access the **Method Options** screen press the option key below it.

## 2.4.2. SELECTING A MENU ITEM

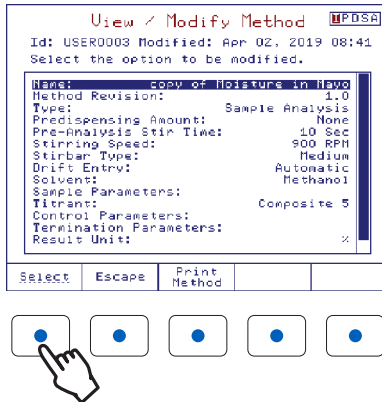

To select an item from the menu screen, use the arrow keys  $\triangle$  and  $\nabla$  to move the cursor.

When the menu is larger than the display, a scroll bar is active on the right side.

To activate the selected menu item, press enter or Select.

## 2.4.3. ENTERING TEXT

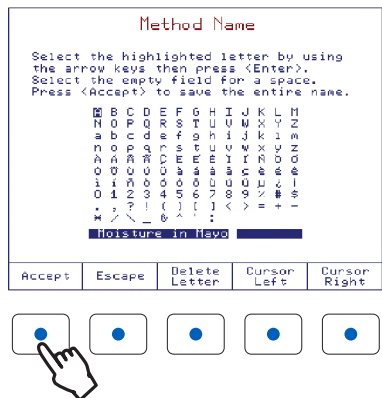

To enter text in an alphanumeric input box, first erase the previous text by using Delete Letter.

To enter a letter, highlight it using the arrow keys then press enter. Use the same procedure to enter the whole name.

For editing, use the Cursor Left and Cursor Right keys.

When editing is complete, press Accept.

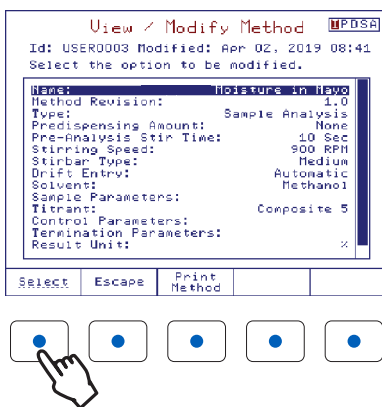

The method name will be updated and displayed in the name field of the **View/Modify Method** screen.

When all the desired parameters have been set, press Escape.

## 2.4.4. SAVING MODIFICATIONS

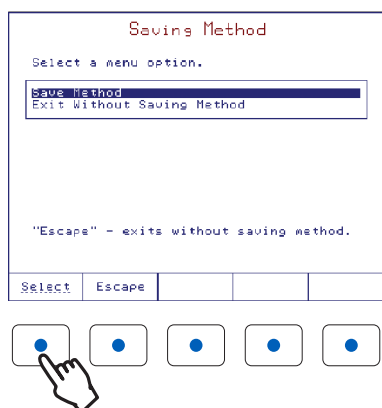

The **Saving Method** screen allows the user to save the modifications. To exit without saving, press Escape or highlight *Exit Without Saving Method* option and then press Select. To save the modifications highlight *Save Method* option and then press Select.

**Note:** To access the contextual help menu, press ? at any time. Help is related to the displayed screen. Press Escape or ? to return to the previous screen.

### 3. GENERAL OPTIONS

The **General Options** screen gives access to options that are not directly related to the titration process. In Idle mode, on the main screen press  to access this screen. In Pre-titration, Standby or during a Titration, press the <<Home>> key on a PS/2 keyboard to access this screen.

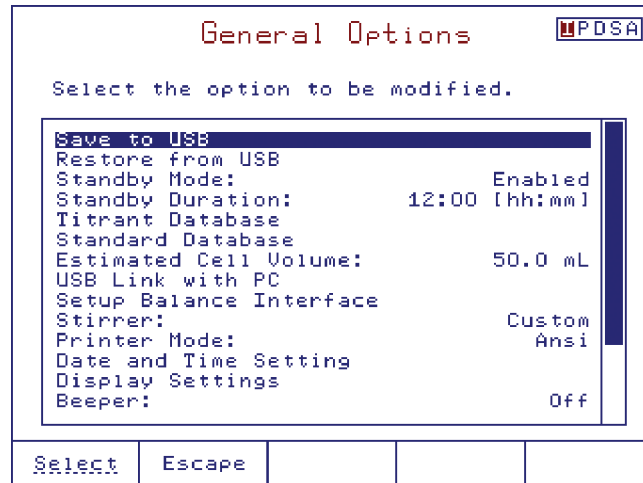

#### 3.1. SAVE FILES TO USB STORAGE DEVICE

**Note:** The USB Storage Device has to be formatted FAT or FAT32.

This option allows the user to save files from the titrator to a USB storage device.

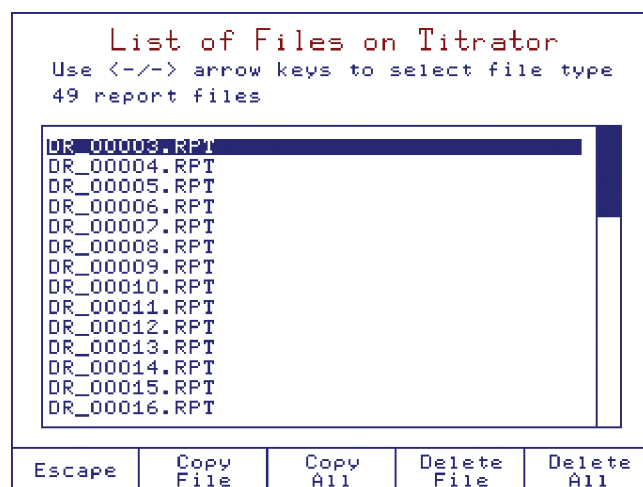

On the titrator, the available file types are:

- Standard Method Files - HIXXXYY.MTD (e.g.: HI8001EN.MTD, HI8101EN.MTD)
- User Method Files - USERXXX.MTD (e.g.: USER0001.MTD)
- Drift/Titration Report Files - DR\_XXXX.RPT, KF\_XXXX.RPT (e.g.: DR\_00001.RPT, KF\_00001.RPT)

Insert the USB storage device into the USB port on the right side of the titrator.

Use the << and >> keys to select the file type. The number of files and the file names will be displayed.

Use the ▲ and ▼ keys to scroll through the list.

The option keys allow the following operations:

Escape	Returns to the <b>General Options</b> screen.
Copy File	Copies the highlighted file from the titrator to the USB storage device.
Copy All	Copies all currently displayed files from the titrator to the USB storage device.
Delete File	Deletes the highlighted file.
Delete All	Deletes all currently displayed files.

**Note:** The saved files will be stored on the USB key in the **HI933** folder, as follows:

- Methods: **USB Drive\HI933\Methods\\*.mtd**
- Reports: **USB Drive\HI933\Reports\\*.rpt**

### 3.2. RESTORE FILES FROM USB STORAGE DEVICE

This screen allows the user to transfer files from the USB storage device to the titrator.

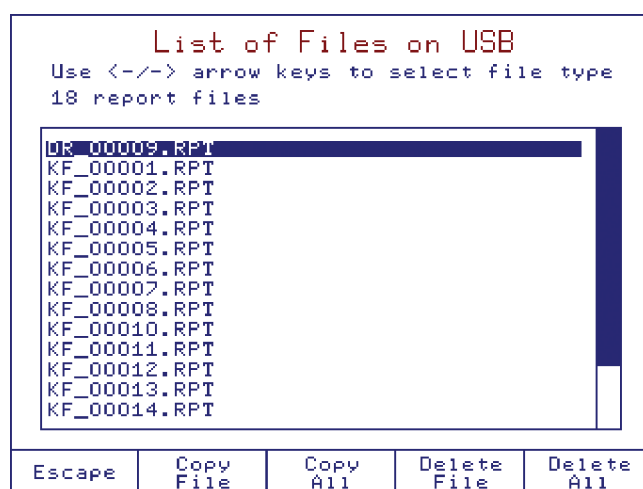

The file types that can be transferred are:

- |                              |   |  |
|------------------------------|---|--|
| Standard Method Files        | - | <b>HIXXXYY.MTD</b> (e.g.: HI8001EN.MTD, HI8101EN.MTD)              |
| User Method Files            | - | <b>USERXXX.MTD</b> (e.g.: USER0001.MTD)                            |
| Drift/Titration Report Files | - | <b>DR_XXXX.RPT, KF_XXXX.RPT</b> (e.g.: DR_00001.RPT, KF_00001.RPT) |

Insert the USB storage device into the USB port on the right side of the titrator.

Use the << and >> keys to select the file type. The number of files and the file names will be displayed.

Use the ▲ and ▼ keys to scroll through the list.

The option keys allow the following operations:

Escape	Returns to the <b>General Options</b> screen.
Copy File	Copies the highlighted file from the USB storage to the titrator.
Copy All	Copies all currently displayed files from the USB storage to the titrator.
Delete File	Deletes the highlighted file.
Delete All	Deletes all currently displayed files.

**Note:** In order to restore files from USB Key, please ensure that the methods and/or reports you wish to transfer to the titrator are in the correct folder:

- Methods: **USB Drive\HI933\Methods\\*.mtd**
- Reports: **USB Drive\HI933\Reports\\*.rpt**

### 3.3. STANDBY MODE

**Option: Disabled or Enabled**

When enabling this option the titrator will return to Standby mode automatically after the titration has been completed.

Standby Mode				
Select the option for standby mode.				
<div style="border: 1px solid black; padding: 2px;">           Disabled  <b>Enabled</b> </div>				
Select	Escape			

### 3.4. STANDBY DURATION

**Option: 10 minutes to 72 hours**

The user can enter the period of time for which the cell is kept dry and ready for subsequent analysis after a titration has finished.

Standby Duration				
Enter time period (at least 10 min.) for which titrator will run in standby mode.				
hours		minutes		
<b>12</b>		00		
Low Limit: 00:10				
High Limit: 72:00				
Press <Next> to move to the next entry.				
Accept	Escape	Delete Digit	Next	

The external stirrer is automatically detected when it is connected.

### 3.5. TITRANT DATABASE

This screen allows the user to store information about titrants, including the name and standardization information.

Titrant Database			
Select the KF titrant to be modified.			
KF Titrant Composite 2 Composite 1			
Titrant Type: One-component Nominal Titrant Conc.: 2.0000 mg/mL Standardized Titrant Conc.: 2.0000 mg/mL Date/Time: Jan 22, 2018 12:18 Titrant Age Reminder: Disabled			
Escape	Edit	New Titrant	Delete

The titrant for the currently-selected method cannot be modified from this screen. For details on the full functionality of the database, see [Method Options](#) section.

### 3.6. STANDARD DATABASE

This screen allows the user to store information about standards, including the name and concentration.

Standard Database			
Select the KF standard to be modified.			
KF Standard Liquid 10 mg/g Liquid 1.0 mg/g Liquid 0.1 mg/g Sodium Tartrate			
Water Content: 10.0000 Concentration Unit: mg/g Type: Liquid by mass Standard Density: 1.000 g/mL			
Escape	Edit	New Standard	Delete

The standard for the currently selected method cannot be modified from this screen. For details on the full functionality of the database, see [Method Options](#) section.

### 3.7. ESTIMATED CELL VOLUME

Option: 0.0 mL to 200.0 mL

Use the numeric keypad to enter the estimated volume of solution in the titration beaker.

Estimated Cell Volume				
Confirm the cell has been filled to the "Min" line or enter approximate cell volume.				
<div style="background-color: black; color: white; display: inline-block; padding: 2px 10px;">50.0 mL</div>				
Low Limit: 0.0 mL High Limit: 200.0 mL				
Accept	Escape	Delete Digit		

### 3.8. USB LINK WITH PC

In order to use this feature, the USB cable needs to be connected from the titrator to the PC. Make sure that **HI900** PC application is running on the PC.

USB Link with PC				
Inactive				
Speed 19200				
	Escape			

"Active/Inactive" shows the status of the USB link with the PC.

"Active" means that the titrator is using the USB communication with the PC and not with another device.

"Ready" shows that the titrator is able to communicate with the PC.

During transfer of any information between the PC and the titrator, "Transmit" and the status is displayed.

**Note:** To allow our users access to the latest version of Hanna Instruments PC compatible software, we made the products available for download at <http://software.hannainst.com>. Select the product code and click **Download Now**. After download is complete, use the *setup.exe* file to install the software.

### 3.9. SETUP BALANCE INTERFACE

This screen allows the user to setup an analytical balance for automatic acquisition of sample mass prior to titration or standardization.

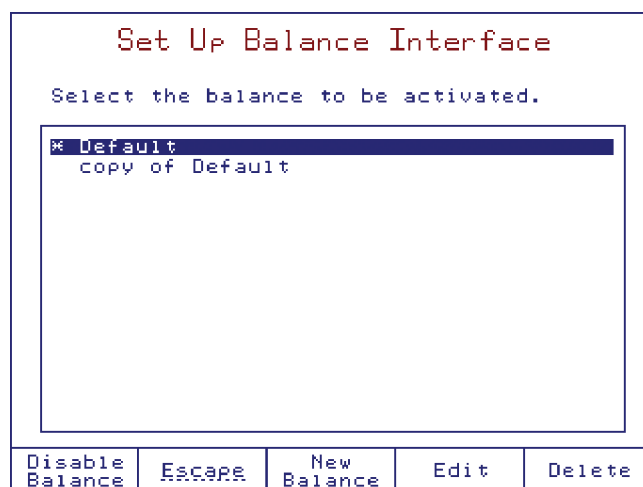

The balance is connected to the titrator via RS 232 interface.

- Enable Balance Enables the selected balance.
- Disable Balance Disables the selected balance (automatic weight acquisition will be not available).
- Escape Returns to the **General Options** screen.
- New Balance Adds a new balance to the list.
- Edit Customizes the serial communication parameters. The **Balance Configuration** screen will open.
- Delete Deletes the highlighted balance.

**Note:** *At least one balance must be in the list.*

Be sure that the balance configuration settings match the settings for your balance (baud rate, data bits, parity, stop bit number, request command syntax). It may be necessary to change settings on your balance. Users should consult their balance instruction manual.

Before leaving this screen be sure the connection with the balance is working properly by pressing the Test Balance key.

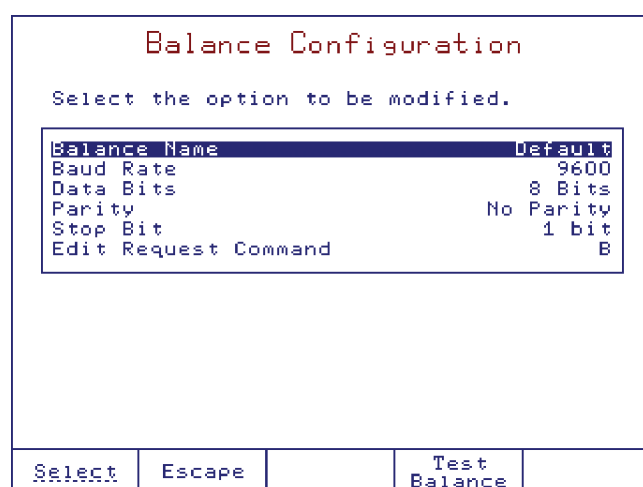

### 3.10. STIRRER

Option: Internal, External, Custom

This screen allows the user to select the internal magnetic stirrer, an external magnetic stirrer or a user-controlled stirrer (custom).

Stirrer							
Select the option.							
<table border="1"><tr><td>Internal</td></tr><tr><td>External</td></tr><tr><td>Custom</td></tr></table>					Internal	External	Custom
Internal							
External							
Custom							
Select	Escape						

### 3.11. PRINTER MODE

Option: Ansi, Ascii, Text

Printer Mode							
Select the option.							
<table border="1"><tr><td>Ansi</td></tr><tr><td>Ascii</td></tr><tr><td>Text</td></tr></table>					Ansi	Ascii	Text
Ansi							
Ascii							
Text							
Select	Escape						

**Ansi mode:** Use this mode when the printer is set as Ansi. In this case all the accented characters/symbols available in titrator will be printed on the printer.

**Ascii mode:** Use this mode when the printer is set as Ascii. In this case only some of the accented characters/symbols available in titrator will be printed on the printer.



**Text mode:** This mode is recommended when the user doesn't need to print accented characters.

### 3.12. DATE AND TIME SETTING

This screen allows the user to set the date and time.

Use the  and  keys or the numeric keys to modify the date and time.

Press  to move the cursor to the next field.

Press  or  to change the time format.

Date and Time Setting				
Enter the date.				
2	10	2018		
day	month	year		
Enter the time.				
20	41	41		
hour	minute	second		
Press <Next> to move to the next entry.				
Accept	Escape	Delete Digit	Next	AM/PM

### 3.13. DISPLAY SETTINGS

This screen allows the user to customize the display settings.

#### Option Keys:

 Increases the backlight saver time interval

 Decreases the backlight saver time interval

The backlight intensity can be adjusted using the  and  keys.

There are 8 levels of backlight intensity, ranging from 0 to 7.

Display Settings			
Use Up/Down keys to adjust Backlight.			
			
Backlight:	3 >>>		
Backlight ON for:	15 minutes		
Escape		Time Increase	Time Decrease

The displayed color palette allows for selection of appropriate backlight intensity.

The backlight saver option protects the display during standby periods, when no keys have been pressed for a set amount of time.

If the backlight is off, any keystroke will re-activate the backlight without performing any action.

The range for backlight saver interval is between 1 and 60 minutes. To disable the backlight saver increase the time to the maximum allowed. The "Off" indication will appear.

### 3.14. BEEPER

**Option: On or Off**

If enabled (on) an audible alert will sound after a titration is completed, when an invalid key is pressed or when a critical error occurs during titration.

Beeper						
Select the option.						
<table border="1"><tr><td>Beeper Off</td></tr><tr><td>Beeper On</td></tr></table>					Beeper Off	Beeper On
Beeper Off						
Beeper On						
Select	Escape					

### 3.15. LANGUAGE

**Option: English, Español, Português, Français**

Set Language								
Select the language.								
<table border="1"><tr><td>English</td></tr><tr><td>Español</td></tr><tr><td>Português</td></tr><tr><td>Français</td></tr></table>					English	Español	Português	Français
English								
Español								
Português								
Français								
Select	Escape							

### 3.16. CALIBRATION CHECK

This screen allows the user to verify the electrode mV input and the electrode polarization current.

Calibration Check				
Connect calibration key to BNC connector. Use accurate multimeter to check the mV/ $\mu$ A accuracy.				
Measured:	225.0 mV			
Imposed Current:	15 $\mu$ A			
Use "Up" and "Down" to modify the current.				
	Escape			

The electrode mV input and the electrode polarization current are measured with the **HI900941** calibration key and a mV/ $\mu$ A multimeter (not included).

Disconnect the KF electrode, then connect the **HI900941** calibration key to the electrode input (BNC connector).

#### To check the mV input:

Set the multimeter to mV mode.

Switch the calibration key to mV mode by pressing the red button.

Connect the calibration key banana plugs to the multimeter mV input.

Use the  $\Delta$  and  $\nabla$  keys to change the imposed current (predefined list).

The millivolt reading displayed on the titrator screen should be within 2% of the reading on the multimeter.

#### To check the $\mu$ A output:

Set the multimeter to  $\mu$ A mode.

Switch the calibration key to  $\mu$ A mode by pressing the red button.

Connect the calibration key banana plugs to the multimeter mA input.

The reading on the multimeter should be in accordance with the prescribed  $\mu$ A value on the titrator screen.

### 3.17. RESET TO DEFAULT SETTINGS

**Note:** This will delete all the user methods and restore all manufacturer settings such as titrator configuration, standard method parameters, etc.

Confirm Reset				
Are you sure you want to reset the titrator to manufacturer settings?				
This will delete all user methods and reports.				
Reset	Escape			

### 3.18. OPTIMIZE MEMORY SPACE

This screen allows the user to run a memory defragmentation utility in order to increase the speed to the storage memory access. Press  and then restart the titrator. Do not disconnect the power supply during this operation.

<b>Optimize Memory Space</b>				
This option is used in order to clean up the memory space.				
Please ensure the power is not disconnected during this operation.				
Accept	Escape			

### 3.19. UPDATE SOFTWARE

This screen allows the user to update the titrator software from a USB storage device containing a software setup kit.

<b>Update Software</b>				
Current version:           HI933 v1.00				
New version:               HI933 v1.01				
Are you sure you want to update the current software with the new version?				
Accept	Escape	Refresh		

To update the software:

- Copy the "**Setup933**" folder to a USB storage device.
- Insert the USB storage device into the titrator.
- Go to **General Options**, then **Update Software**. The titrator will display the current and new software versions.
- Press . When prompted, remove the USB storage device and restart the titrator.

## 4. TITRATION METHODS

All parameters required to complete an analysis are grouped into a method.

The titrator is supplied with a pack of standard methods, these methods have been developed by Hanna Instruments and can be used to create user methods.

Standard and user methods can be upgraded, saved or deleted by connecting the titrator to a PC using the [HI900](#) PC application or a USB flash drive.

### 4.1. SELECTING METHODS

To select a method, press  from the main screen. A list of available methods will be displayed.

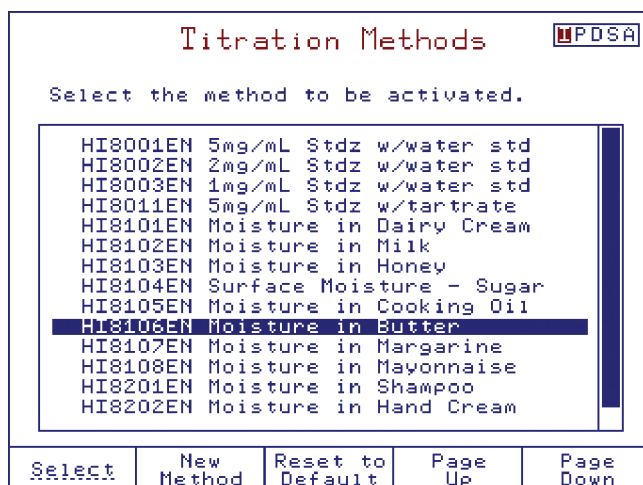

In the **Titration Methods** screen, you can view the list of all available methods (standard and user methods).

To select a method, highlight the method then press , the name of the selected method will be displayed on the main screen.

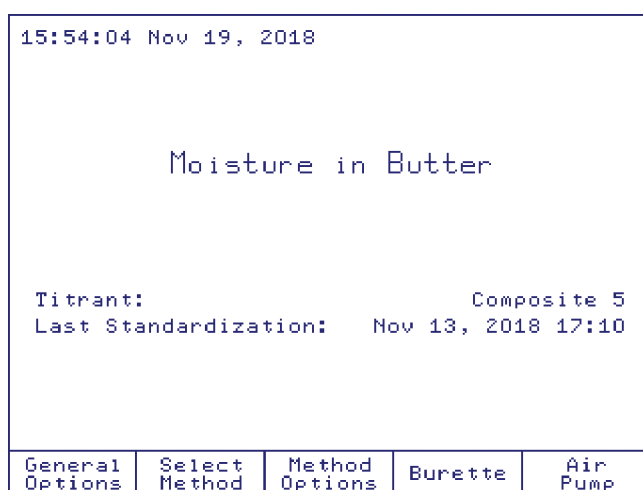

### 4.2. STANDARD METHODS

The standard methods are developed for the most common types of analysis.

Only specific method parameters can be modified by the user (see [Method Options](#) section).

Also, standard methods can be used as a template to create new user methods.

### 4.2.1. UPGRADING STANDARD METHODS

To upgrade the titrator with new standard methods, follow the steps below:

**From USB storage device:**

- Insert the USB storage device into the USB port, located on the right side of the titrator.
- Press **General Options** from the main screen.
- Using **▲** and **▼** keys, highlight *Restore from USB Storage Device* option and choose **Select**.
- Using **<** and **>** keys, navigate through file types to find "standard method files". The list with available standard methods will be displayed.
- Press the **Copy File** or **Copy All** key to upgrade the titrator with the standard methods.
- Press **Escape** to return to **General Options** screen.

**From PC:**

You can upgrade the titrator with standard methods from a PC using the **HI900** PC application (see **General Options** section).

### 4.2.2. DELETING STANDARD METHODS

Unnecessary standard methods can be removed from the titrator by following the procedure below:

**From General Options Screen:**

- Using the **▲** and **▼** keys, highlight *Save to USB* option and press **Select**.
- Using the **<** and **>** keys, navigate through the file types menu to find "standard method files". The available standard methods will be displayed.
- Press the **Delete** or **Delete All** keys to remove unnecessary standard methods.
- Press **Escape** to return to the **General Options** screen.

**From PC:**

Unnecessary standard methods can be removed from the titrator using the **HI900** PC application (see **General Options** section).

### 4.2.3. RESTORING THE STANDARD METHODS TO THE MANUFACTURER SETTINGS

You can restore the standard methods to the default settings by highlighting a standard method and pressing **Reset to Default**.

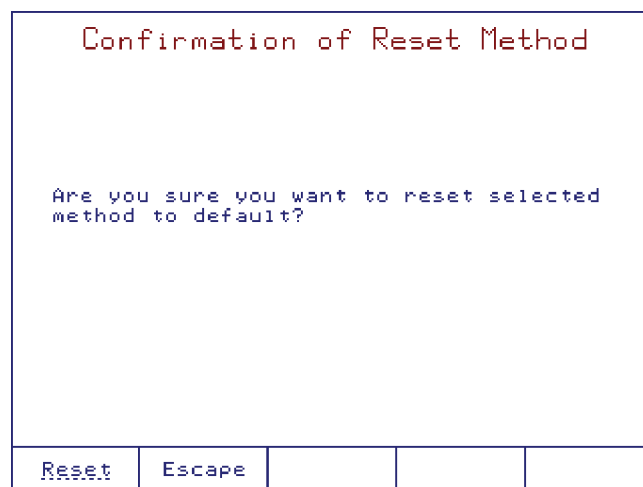

### 4.3. USER METHODS

These methods are defined by the user (usually by modifying a standard method).

The user methods can be developed in accordance with the requirements of the user. All method parameters can be modified by the user.

#### 4.3.1. CREATING USER METHODS

To create a new user method, start from a standard or previously generated user method and follow these steps:

- Press  from the main screen.
- Using the  and  keys, highlight an existing method from the method list.
- Press . A new user method will be generated.
- Press  to activate the recently generated user method.

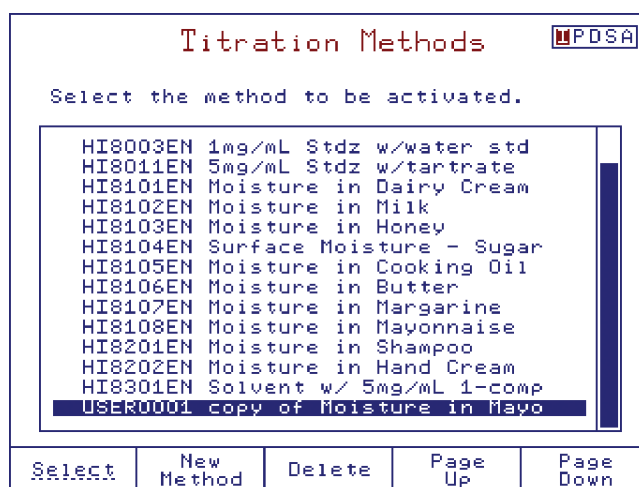

**Note:** Only a limited number of methods can be installed on the titrator. The titrator can hold 100 methods (standard and user). When the limit is reached, a warning message is displayed.

#### 4.3.2. DELETING USER METHODS

To remove a user method, press  from the main screen. Highlight the user method that you want to delete and press . A screen will appear in order to confirm the deletion. Press  again to confirm, or press  to cancel the operation.



#### 4.4. VIEWING / MODIFYING METHOD

To modify the method parameters, press Method Options from the main screen. A list of all the parameters for the selected method will be displayed. Press the ▲ and ▼ keys to highlight the option you want to modify and choose Select.

View / Modify Method		PDSA
Id: USER0003 Modified: Apr 02, 2019 08:41		
Select the option to be modified.		
Name:	copy of Moisture in Mayo	
Method Revision:	1.0	
Type:	Sample Analysis	
Predispensing Amount:	None	
Pre-Analysis Stir Time:	10 Sec	
Stirring Speed:	900 RPM	
Stirbar Type:	Medium	
Drift Entry:	Automatic	
Solvent:	Methanol	
Sample Parameters:		
Titrant:	Composite 5	
Control Parameters:		
Termination Parameters:		
Result Unit:	%	
Select	Escape	Print Method

To exit the **View/Modify Method** screen, press the Escape key, and highlight *Save Method* and press Select to save modifications.

Press Escape to discard the changes.

Saving Method	
Select a menu option.	
Save Method	Exit Without Saving Method
"Escape" - exits without saving method.	
Select	Escape

## 4.5. METHOD OPTIONS

*Note: Only certain method options can be changed for standard methods.*

### 4.5.1. NAME

Option: Up to 24 characters

Method Name				
Select the highlighted letter by using the arrow keys then press <Enter>. Select the empty field for a space. Press <Accept> to save the entire name.				
<pre> B C D E F G H I J K L M N O P Q R S T U V W X Y Z a b c d e f g h i j k l m n o p q r s t u v w x y z À Á Â Ã Ä Å Æ Ç È É Ê Ë Ì Í Î Ï Ñ Ò Ó Ô Õ Ö Ü à á â ã ä å ç è é ê ë ì í î ï ð ó ô õ ö ù ú û ü ý ÿ 0 1 2 3 4 5 6 7 8 9 % # \$ . , ? ! ( ) [ ] &lt; &gt; = + - * / \ _ @ ^ ' : </pre>				
Water in Butter				
Accept	Escape	Delete Letter	Cursor Left	Cursor Right

### 4.5.2. METHOD REVISION

Option: Up to 3 characters

Method Revision				
Select the highlighted letter by using the arrow keys then press <Enter>. Select the empty field for a space. The revision string format is "X.X".				
<pre> B C D E F G H I J K L M N O P Q R S T U V W X Y Z a b c d e f g h i j k l m n o p q r s t u v w x y z À Á Â Ã Ä Å Æ Ç È É Ê Ë Ì Í Î Ï Ñ Ò Ó Ô Õ Ö Ü à á â ã ä å ç è é ê ë ì í î ï ð ó ô õ ö ù ú û ü ý ÿ 0 1 2 3 4 5 6 7 8 9 % # \$ . , ? ! ( ) [ ] &lt; &gt; = + - * / \ _ @ ^ ' : </pre>				
1.0				
Accept	Escape	Delete Letter	Cursor Left	Cursor Right

### 4.5.3. METHOD TYPE

Option: Sample Analysis or Titrant Standardization

Method Type						
Choose the method application type.						
<table border="1"> <tr> <td>Sample Analysis</td> </tr> <tr> <td>Titrant Standardization</td> </tr> </table>					Sample Analysis	Titrant Standardization
Sample Analysis						
Titrant Standardization						
Select	Escape					

### 4.5.4. PREDISPENSING AMOUNT

Option: 0% to 90%

If the approximate water content is known, the titration time can be shortened by adding a large fraction of the titrant at the start.

Predispensing Amount						
Enter the percentage of titrant volume that will be predispensed.						
<table border="1"> <tr> <td>40</td> <td>%</td> </tr> </table>					40	%
40	%					
Low Limit: 0 %						
High Limit: 90 %						
Accept	Escape	Delete Digit				

To disable this feature set the predispensing amount to 0%.

#### 4.5.5. PRE-ANALYSIS STIR TIME

Option: 0 to 1000 seconds

To avoid erroneous results or unreachable end points when analyzing samples with limited solubility, the sample must be completely dissolved in the solvent prior to the start of a titration.

After the sample has been added to the titration beaker, the titrator will stir for the set period of time before any titrant (excluding predispending) is added to the cell.

<b>Pre-Analysis Stir Time</b>				
Enter the initial mixing time prior to the start of the titration.				
█ 10 seconds				
Low Limit: 0 seconds High Limit: 1000 seconds				
Accept	Escape	Delete Digit		

#### 4.5.6. STIRRER SPEED

Option: 200 to 2000 RPM

<b>Stirring Speed</b>				
Enter the speed of the stirrer during the titration.				
█ 500 RPM				
Low Limit: 200 RPM High Limit: 2000 RPM				
Accept	Escape	Delete Digit		

The stirrer will remain on for as long as the method is active. When the stirrer is running, the speed can be adjusted at any time by using the  and  keys.



#### 4.5.9. SOLVENT NAME

Option: Up to 15 characters

Solvent Name

Select the highlighted letter by using the arrow keys then press <Enter>. Select the empty field for a space. Press <Accept> to save the entire name.

█	B	C	D	E	F	G	H	I	J	K	L	M
N	O	P	Q	R	S	T	U	V	W	X	Y	Z
a	b	c	d	e	f	g	h	i	j	k	l	m
n	o	p	q	r	s	t	u	v	w	x	y	z
À	Á	Â	Ã	Ç	È	É	Ê	Ë	Ì	Í	Î	Ï
Ò	Ó	Ô	Õ	à	á	â	ã	ä	å	æ	ç	è
ì	í	î	ï	ó	ô	õ	ö	ù	ú	û	ü	ÿ
0	1	2	3	4	5	6	7	8	9	%	#	\$
.	,	?	!	(	)	[	]	<	>	=	+	-
*	/	\	_	~	^	'	:					

█Methanol

Accept	Escape	Delete Letter	Cursor Left	Cursor Right
--------	--------	---------------	-------------	--------------

#### 4.5.10. SAMPLE PARAMETERS (SAMPLE ANALYSIS ONLY)

This screen allows the user to configure parameters for the sample to be analyzed.

Sample Parameters

Select the option to be modified.

Sample Determ.:	External Dissolution
Sample Name:	Butter
Sample Size:	0.7500 g
External Solvent Size:	40.0000 g
External Solvent Conc.:	0.0100 %
Dissolved Sample Size:	3.0000 g

Select	Escape			
--------	--------	--	--	--

##### 4.5.10.1. SAMPLE DETERMINATION

Option: Normal, External Extraction, External Dissolution

Sample Determination

Select the sample determination mode.

Normal
External Extraction
External Dissolution

Select	Escape			
--------	--------	--	--	--

**Normal:** The analysis is performed through direct titration of the sample. The sample is soluble in the solvent or finely divided with a homogeneous distribution of water.

**External extraction:** The sample is insoluble in the solvent and an external water extraction is necessary.

**External dissolution:** The sample has very high water content, non-homogeneous water distribution, or is slow to dissolve. The sample is dissolved in a separate container and then a small amount of the solvent is titrated.

See [Optimization](#) section for further details.

#### 4.5.10.1.1. NORMAL

Sample Parameters												
Select the option to be modified.												
<table border="1"> <tr> <td>Sample Determ.:</td> <td>Normal</td> </tr> <tr> <td>Sample Name:</td> <td>Mayonnaise</td> </tr> <tr> <td>Sample Type:</td> <td>Mass</td> </tr> <tr> <td>Sample Size:</td> <td>0.7500 g</td> </tr> </table>					Sample Determ.:	Normal	Sample Name:	Mayonnaise	Sample Type:	Mass	Sample Size:	0.7500 g
Sample Determ.:	Normal											
Sample Name:	Mayonnaise											
Sample Type:	Mass											
Sample Size:	0.7500 g											
Select	Escape											

#### Sample Name

Option: Up to 15 characters

Sample Name									
Select the highlighted letter by using the arrow keys then press <Enter>. Select the empty field for a space. Press <Accept> to save the sample name.									
<pre> [ ] B C D E F G H I J K L M N O P Q R S T U V W X Y Z a b c d e f g h i j k l m n o p q r s t u v w x y z A A Å Ä Ç È É Ê Ë Ì Í Î Ï Ñ Ò Ó 0 0 0 0 0 à á â ã ä å ç è é ê ë i í ñ ò ó ô õ ö ù ú û ü ý ÿ 0 1 2 3 4 5 6 7 8 9 * # \$ . , ? ! ( ) [ ] &lt; &gt; = + - * / \ _ ` ^ ' : </pre>									
<table border="1"> <tr> <td></td> <td>Mayonnaise</td> <td></td> <td></td> <td></td> </tr> </table>						Mayonnaise			
	Mayonnaise								
Accept	Escape	Delete Letter	Cursor Left	Cursor Right					

## Sample Type

Option: Mass, Volume, Pieces

Sample Type				
Choose the sample amount type.				
<div style="border: 1px solid black; padding: 2px;">           Mass            Volume            Pieces         </div>				
Select	Escape			

## Sample Size

Option: 0.0010 to 100.0000 g, 0.0010 to 100.0000 mL, 1 to 100 pcs.

Sample Size				
Enter the sample size in current unit.				
<div style="border: 1px solid black; display: inline-block; padding: 2px;">0.7500</div> g				
Low Limit: 0.0010 g High Limit: 100.0000 g				
Accept	Escape	Delete Digit		

Sample Size				
Enter the sample size in current unit.				
<div style="border: 1px solid black; display: inline-block; padding: 2px;">1</div> pcs				
Low Limit: 1 pcs High Limit: 100 pcs				
Accept	Escape	Delete Digit		

Sample Density (by volume only)

Option: 0.200 to 3.000 g/mL

Sample Density				
Enter the value of sample density.				
1.000 g/mL				
Low Limit: 0.200 g/mL High Limit: 3.000 g/mL				
Accept	Escape	Delete Digit		

#### 4.5.10.1.2. EXTERNAL EXTRACTION

Sample Parameters																
Select the option to be modified.																
<table border="1"> <tbody> <tr> <td>Sample Determ.:</td> <td>External Extraction</td> </tr> <tr> <td>Sample Name:</td> <td>Mayonnaise</td> </tr> <tr> <td>Sample Size:</td> <td>0.7500 g</td> </tr> <tr> <td>External Solvent Size:</td> <td>40.0000 g</td> </tr> <tr> <td>External Solvent Conc.:</td> <td>0.0100 %</td> </tr> <tr> <td>Extracted Sample Size:</td> <td>1.0000 g</td> </tr> </tbody> </table>					Sample Determ.:	External Extraction	Sample Name:	Mayonnaise	Sample Size:	0.7500 g	External Solvent Size:	40.0000 g	External Solvent Conc.:	0.0100 %	Extracted Sample Size:	1.0000 g
Sample Determ.:	External Extraction															
Sample Name:	Mayonnaise															
Sample Size:	0.7500 g															
External Solvent Size:	40.0000 g															
External Solvent Conc.:	0.0100 %															
Extracted Sample Size:	1.0000 g															
Select	Escape															

Sample Name

Option: Up to 15 characters

Sample Name																																																																																																																																																																	
Select the highlighted letter by using the arrow keys then press <Enter>. Select the empty field for a space. Press <Accept> to save the sample name.																																																																																																																																																																	
<table border="0"> <tbody> <tr> <td>␣</td><td>B</td><td>C</td><td>D</td><td>E</td><td>F</td><td>G</td><td>H</td><td>I</td><td>J</td><td>K</td><td>L</td><td>M</td> </tr> <tr> <td>N</td><td>O</td><td>P</td><td>Q</td><td>R</td><td>S</td><td>T</td><td>U</td><td>V</td><td>W</td><td>X</td><td>Y</td><td>Z</td> </tr> <tr> <td>a</td><td>b</td><td>c</td><td>d</td><td>e</td><td>f</td><td>g</td><td>h</td><td>i</td><td>j</td><td>k</td><td>l</td><td>m</td> </tr> <tr> <td>n</td><td>o</td><td>p</td><td>q</td><td>r</td><td>s</td><td>t</td><td>u</td><td>v</td><td>w</td><td>x</td><td>y</td><td>z</td> </tr> <tr> <td>À</td><td>Á</td><td>Â</td><td>Ã</td><td>Ä</td><td>Å</td><td>Æ</td><td>Ç</td><td>È</td><td>É</td><td>Ê</td><td>Ë</td><td>Ì</td><td>Í</td><td>Î</td><td>Ï</td><td>Ð</td><td>Ó</td><td>Ô</td><td>Õ</td><td>Ö</td><td>×</td><td>è</td><td>é</td><td>ê</td><td>ë</td> </tr> <tr> <td>ì</td><td>í</td><td>î</td><td>ï</td><td>ò</td><td>ó</td><td>ô</td><td>õ</td><td>ö</td><td>ù</td><td>ú</td><td>û</td><td>ü</td><td>ý</td><td>ÿ</td><td>ÿ</td><td>ÿ</td><td>ÿ</td><td>ÿ</td><td>ÿ</td><td>ÿ</td><td>ÿ</td><td>ÿ</td><td>ÿ</td><td>ÿ</td><td>ÿ</td><td>ÿ</td> </tr> <tr> <td>0</td><td>1</td><td>2</td><td>3</td><td>4</td><td>5</td><td>6</td><td>7</td><td>8</td><td>9</td><td>%</td><td>#</td><td>\$</td><td></td><td></td><td></td><td></td><td></td><td></td><td></td><td></td><td></td><td></td><td></td><td></td><td></td> </tr> <tr> <td>*</td><td>/</td><td>\</td><td>_</td><td>^</td><td>'</td><td>:</td><td></td><td></td><td></td><td></td><td></td><td></td><td></td><td></td><td></td><td></td><td></td><td></td><td></td><td></td><td></td><td></td><td></td><td></td><td></td> </tr> </tbody> </table>					␣	B	C	D	E	F	G	H	I	J	K	L	M	N	O	P	Q	R	S	T	U	V	W	X	Y	Z	a	b	c	d	e	f	g	h	i	j	k	l	m	n	o	p	q	r	s	t	u	v	w	x	y	z	À	Á	Â	Ã	Ä	Å	Æ	Ç	È	É	Ê	Ë	Ì	Í	Î	Ï	Ð	Ó	Ô	Õ	Ö	×	è	é	ê	ë	ì	í	î	ï	ò	ó	ô	õ	ö	ù	ú	û	ü	ý	ÿ	ÿ	ÿ	ÿ	ÿ	ÿ	ÿ	ÿ	ÿ	ÿ	ÿ	ÿ	ÿ	0	1	2	3	4	5	6	7	8	9	%	#	\$														*	/	\	_	^	'	:																			
␣	B	C	D	E	F	G	H	I	J	K	L	M																																																																																																																																																					
N	O	P	Q	R	S	T	U	V	W	X	Y	Z																																																																																																																																																					
a	b	c	d	e	f	g	h	i	j	k	l	m																																																																																																																																																					
n	o	p	q	r	s	t	u	v	w	x	y	z																																																																																																																																																					
À	Á	Â	Ã	Ä	Å	Æ	Ç	È	É	Ê	Ë	Ì	Í	Î	Ï	Ð	Ó	Ô	Õ	Ö	×	è	é	ê	ë																																																																																																																																								
ì	í	î	ï	ò	ó	ô	õ	ö	ù	ú	û	ü	ý	ÿ	ÿ	ÿ	ÿ	ÿ	ÿ	ÿ	ÿ	ÿ	ÿ	ÿ	ÿ	ÿ																																																																																																																																							
0	1	2	3	4	5	6	7	8	9	%	#	\$																																																																																																																																																					
*	/	\	_	^	'	:																																																																																																																																																											
Mayonnaise																																																																																																																																																																	
Accept	Escape	Delete Letter	Cursor Left	Cursor Right																																																																																																																																																													

## Sample Size

Option: 0.0010 to 100.0000 g

Sample Size				
Enter the sample size in current unit.				
0.7500 g				
Low Limit: 0.0010 g				
High Limit: 100.0000 g				
Accept	Escape	Delete Digit		

## External Solvent Size

Option: 0.0010 to 100.0000 g

External Solvent Size				
Enter the size of the solvent used to prepare the supernatant.				
40.0000 g				
Low Limit: 0.0010 g				
High Limit: 100.0000 g				
Accept	Escape	Delete Digit		

## External Solvent Concentration

Option: 0.0100 to 100.0000 %

External Solvent Concentration				
Enter the solvent concentration used to prepare the supernatant.				
0.0100 %				
Low Limit: 0.0100 %				
High Limit: 100.0000 %				
Accept	Escape	Delete Digit		

## Extracted Sample Size

Option: 0.0010 to 100.0000 g

Extracted Sample Size				
Enter the extracted sample size used to prepare the supernatant.				
1.00000 g				
Low Limit: 0.0010 g High Limit: 100.0000 g				
Accept	Escape	Delete Digit		

## 4.5.10.1.3. EXTERNAL DISSOLUTION

Sample Parameters																
Select the option to be modified.																
<table border="1"> <tbody> <tr> <td>Sample Determ.:</td> <td>External Dissolution</td> </tr> <tr> <td>Sample Name:</td> <td>Mayonnaise</td> </tr> <tr> <td>Sample Size:</td> <td>0.7500 g</td> </tr> <tr> <td>External Solvent Size:</td> <td>40.0000 g</td> </tr> <tr> <td>External Solvent Conc.:</td> <td>0.0100 %</td> </tr> <tr> <td>Dissolved Sample Size:</td> <td>1.0000 g</td> </tr> </tbody> </table>					Sample Determ.:	External Dissolution	Sample Name:	Mayonnaise	Sample Size:	0.7500 g	External Solvent Size:	40.0000 g	External Solvent Conc.:	0.0100 %	Dissolved Sample Size:	1.0000 g
Sample Determ.:	External Dissolution															
Sample Name:	Mayonnaise															
Sample Size:	0.7500 g															
External Solvent Size:	40.0000 g															
External Solvent Conc.:	0.0100 %															
Dissolved Sample Size:	1.0000 g															
Select	Escape															

## Sample Name

Option: Up to 15 characters

Sample Name																																																																																																																																															
Select the highlighted letter by using the arrow keys then press <Enter>. Select the empty field for a space. Press <Accept> to save the sample name.																																																																																																																																															
<table border="1"> <tbody> <tr> <td>␣</td> <td>B</td> <td>C</td> <td>D</td> <td>E</td> <td>F</td> <td>G</td> <td>H</td> <td>I</td> <td>J</td> <td>K</td> <td>L</td> <td>M</td> </tr> <tr> <td></td> <td>N</td> <td>O</td> <td>P</td> <td>Q</td> <td>R</td> <td>S</td> <td>T</td> <td>U</td> <td>V</td> <td>W</td> <td>X</td> <td>Y</td> <td>Z</td> </tr> <tr> <td></td> <td>a</td> <td>b</td> <td>c</td> <td>d</td> <td>e</td> <td>f</td> <td>g</td> <td>h</td> <td>i</td> <td>j</td> <td>k</td> <td>l</td> <td>m</td> </tr> <tr> <td></td> <td>n</td> <td>o</td> <td>p</td> <td>q</td> <td>r</td> <td>s</td> <td>t</td> <td>u</td> <td>v</td> <td>w</td> <td>x</td> <td>y</td> <td>z</td> </tr> <tr> <td></td> <td>À</td> <td>Á</td> <td>Â</td> <td>Ã</td> <td>Ä</td> <td>Å</td> <td>Æ</td> <td>Ç</td> <td>È</td> <td>É</td> <td>Ê</td> <td>Ë</td> <td>Ì</td> </tr> <tr> <td></td> <td>Í</td> <td>Î</td> <td>Ï</td> <td>Ñ</td> <td>Ò</td> <td>Ó</td> <td>Ô</td> <td>Õ</td> <td>Ö</td> <td>×</td> <td>è</td> <td>é</td> <td>ê</td> </tr> <tr> <td></td> <td>ì</td> <td>í</td> <td>î</td> <td>ï</td> <td>ò</td> <td>ó</td> <td>ô</td> <td>õ</td> <td>ö</td> <td>÷</td> <td>ü</td> <td>ú</td> <td>û</td> </tr> <tr> <td></td> <td>0</td> <td>1</td> <td>2</td> <td>3</td> <td>4</td> <td>5</td> <td>6</td> <td>7</td> <td>8</td> <td>9</td> <td>%</td> <td>#</td> <td>\$</td> </tr> <tr> <td></td> <td>.</td> <td>,</td> <td>?</td> <td>!</td> <td>(</td> <td>)</td> <td>[</td> <td>]</td> <td>&lt;</td> <td>&gt;</td> <td>=</td> <td>+</td> <td>-</td> </tr> <tr> <td></td> <td>*</td> <td>/</td> <td>\</td> <td>_</td> <td>ˆ</td> <td>^</td> <td>'</td> <td>:</td> <td></td> <td></td> <td></td> <td></td> <td></td> </tr> </tbody> </table>					␣	B	C	D	E	F	G	H	I	J	K	L	M		N	O	P	Q	R	S	T	U	V	W	X	Y	Z		a	b	c	d	e	f	g	h	i	j	k	l	m		n	o	p	q	r	s	t	u	v	w	x	y	z		À	Á	Â	Ã	Ä	Å	Æ	Ç	È	É	Ê	Ë	Ì		Í	Î	Ï	Ñ	Ò	Ó	Ô	Õ	Ö	×	è	é	ê		ì	í	î	ï	ò	ó	ô	õ	ö	÷	ü	ú	û		0	1	2	3	4	5	6	7	8	9	%	#	\$		.	,	?	!	(	)	[	]	<	>	=	+	-		*	/	\	_	ˆ	^	'	:					
␣	B	C	D	E	F	G	H	I	J	K	L	M																																																																																																																																			
	N	O	P	Q	R	S	T	U	V	W	X	Y	Z																																																																																																																																		
	a	b	c	d	e	f	g	h	i	j	k	l	m																																																																																																																																		
	n	o	p	q	r	s	t	u	v	w	x	y	z																																																																																																																																		
	À	Á	Â	Ã	Ä	Å	Æ	Ç	È	É	Ê	Ë	Ì																																																																																																																																		
	Í	Î	Ï	Ñ	Ò	Ó	Ô	Õ	Ö	×	è	é	ê																																																																																																																																		
	ì	í	î	ï	ò	ó	ô	õ	ö	÷	ü	ú	û																																																																																																																																		
	0	1	2	3	4	5	6	7	8	9	%	#	\$																																																																																																																																		
	.	,	?	!	(	)	[	]	<	>	=	+	-																																																																																																																																		
	*	/	\	_	ˆ	^	'	:																																																																																																																																							
Mayonnaise																																																																																																																																															
Accept	Escape	Delete Letter	Cursor Left	Cursor Right																																																																																																																																											

## Sample Size

Option: 0.0010 to 100.0000 g

<b>Sample Size</b>				
Enter the sample size in current unit.				
<div style="border: 1px solid black; display: inline-block; padding: 2px;">0.7500</div> g				
Low Limit: 0.0010 g High Limit: 100.0000 g				
Accept	Escape	Delete Digit		

## External Solvent Size

Option: 0.0010 to 100.0000 g

<b>External Solvent Size</b>				
Enter the size of the solvent used to prepare the supernatant.				
<div style="border: 1px solid black; display: inline-block; padding: 2px;">40.0000</div> g				
Low Limit: 0.0010 g High Limit: 100.0000 g				
Accept	Escape	Delete Digit		

## External Solvent Concentration

Option: 0.0100 to 100.0000 %

<b>External Solvent Concentration</b>				
Enter the solvent concentration used to prepare the supernatant.				
<div style="border: 1px solid black; display: inline-block; padding: 2px;">0.0100</div> %				
Low Limit: 0.0100 % High Limit: 100.0000 %				
Accept	Escape	Delete Digit		

## Dissoluted Sample Size

Option: 0.0010 to 100.0000 g

Dissoluted Sample Size				
Enter the dissoluted sample size used to prepare the supernatant.				
1.00000 g				
Low Limit: 0.0010 g				
High Limit: 100.0000 g				
ACCEPT	Escape	Delete Digit		

## 4.5.11. STANDARD (TITRANT STANDARDIZATION ONLY)

This screen allows the user create a database with standards and customize related parameters.

Using the  $\triangle$  and  $\nabla$  keys, highlight the standard from the existing list and press  to choose it.

Standard Database														
Select the KF standard to be modified.														
<table border="1"> <thead> <tr> <th colspan="2">KF Standard</th> </tr> </thead> <tbody> <tr> <td>Liquid 10 mg/g</td> <td style="background-color: #e0e0e0;"></td> </tr> <tr> <td>Liquid 1.0 mg/g</td> <td></td> </tr> <tr> <td>Liquid 0.1 mg/g</td> <td></td> </tr> <tr> <td>Sodium Tartrate</td> <td></td> </tr> </tbody> </table>					KF Standard		Liquid 10 mg/g		Liquid 1.0 mg/g		Liquid 0.1 mg/g		Sodium Tartrate	
KF Standard														
Liquid 10 mg/g														
Liquid 1.0 mg/g														
Liquid 0.1 mg/g														
Sodium Tartrate														
<table border="1"> <tbody> <tr> <td>Water Content:</td> <td>10.0000</td> </tr> <tr> <td>Concentration Unit:</td> <td>mg/g</td> </tr> <tr> <td>Type:</td> <td>Liquid by mass</td> </tr> <tr> <td>Standard Density:</td> <td>1.000 g/mL</td> </tr> </tbody> </table>					Water Content:	10.0000	Concentration Unit:	mg/g	Type:	Liquid by mass	Standard Density:	1.000 g/mL		
Water Content:	10.0000													
Concentration Unit:	mg/g													
Type:	Liquid by mass													
Standard Density:	1.000 g/mL													
Select	Escape	Edit	New Standard	Delete										

Press  if you want to use the selected standard for the titrant standardization.

Press  to return to the View/Modify Methods screen.

Press  if you want to edit the Karl Fischer standard parameters.

Press  if you want to create and add a new standard to the Karl Fischer standard data base.

Press  if you want to remove a Karl Fischer standard from the pre-defined list.

Titration standardization methods supplied by Hanna are designed to be used with specific standards. The HI933 will automatically select an appropriate standard when such a method is selected. If this standard is not in the database, a new one will be created.

**KF Standard Options**

Select the option to be modified.

Name:	Liquid 10 mg/g
Type:	Liquid by mass
Concentration Unit:	mg/g
Water Content:	10.0000

Select	Escape			
--------	--------	--	--	--

#### 4.5.11.1. STANDARD NAME

Option: up to 15 characters

**Standard Name**

Select the highlighted letter by using the arrow keys then press <Enter>. Select the empty field for a space. Press <Accept> to save the entire name.

█	B	C	D	E	F	G	H	I	J	K	L	M
N	O	P	Q	R	S	T	U	V	W	X	Y	Z
a	b	c	d	e	f	g	h	i	j	k	l	m
n	o	p	q	r	s	t	u	v	w	x	y	z
À	Á	Â	Ã	Ä	Å	Æ	Ç	È	É	Ê	Ë	Ì
Í	Î	Ï	Ñ	Ò	Ó	Ô	Õ	Ö	Ù	Ú	Û	Ü
Ý	ÿ	ı	İ	ı	ı	ı	ı	ı	ı	ı	ı	ı
0	1	2	3	4	5	6	7	8	9	%	#	\$
.	,	!	(	)	[	]	<	>	=	+	-	
*	/	\	_	~	^	'	:					

█ Liquid 10 mg/g █

Accept	Escape	Delete Letter	Cursor Left	Cursor Right
--------	--------	---------------	-------------	--------------

#### 4.5.11.2. STANDARD TYPE

Option: Solid by mass, Liquid by mass, or Liquid by volume

**Standard Type**

Select the Karl Fischer standard type.

Solid by mass
Liquid by mass
Liquid by volume

Select	Escape			
--------	--------	--	--	--

## 4.5.11.3. CONCENTRATION UNIT

Option: %[W/W], ppm, mg/g or mg/mL

Standard Concentration Unit								
Select the standard concentration unit.								
<table border="1"> <tr> <td>%[W/W]</td> </tr> <tr> <td>ppm</td> </tr> <tr> <td><b>mg/g</b></td> </tr> <tr> <td>mg/mL</td> </tr> </table>					%[W/W]	ppm	<b>mg/g</b>	mg/mL
%[W/W]								
ppm								
<b>mg/g</b>								
mg/mL								
Select	Escape							

## 4.5.11.4. WATER CONTENT

Option: 0.0100 to 1000.0000 mg/g

Standard Concentration						
Enter the standard concentration.						
<p style="text-align: center;"> <table border="1"> <tr> <td>10.0000</td> <td>mg/g</td> </tr> </table> </p>					10.0000	mg/g
10.0000	mg/g					
Low Limit: 0.0100 mg/g High Limit: 1000.0000 mg/g						
Accept	Escape	Delete Digit				

#### 4.5.11.5. STANDARD SIZE

Option: 0.0010 to 50.0000 g

Use the numeric keypad to enter the size (g or mL) to be used in the standardization.

When a new standardization is started the titrator will prompt for the exact mass or volume. The standard size can be acquired automatically from a compatible balance when this feature is enabled.

<b>Standard Size</b>				
Enter the value for standard size.				
0.0000 g				
Low Limit: 0.0010 g				
High Limit: 50.0000 g				
Accept	Escape	Delete Digit		

#### 4.5.11.6. STANDARD DENSITY (LIQUID BY VOLUME ONLY)

Option: 0.200 to 3.000 g/mL

<b>Standard Density</b>				
Enter the value of standard density.				
1.000 g/mL				
Low Limit: 0.200 g/mL				
High Limit: 3.000 g/mL				
Accept	Escape	Delete Digit		

#### 4.5.12. TITRANT

The user can access the Karl Fischer titrant database and customize related parameters.

Using the  $\triangle$  and  $\nabla$  keys, highlight the titrant from the existing list and press Select to choose it.

Titrant Database				
Select the KF titrant to be modified.				
<div style="background-color: #e0e0e0; padding: 2px;">Composite 5</div> Composite 2 Composite 1				
Titrant Type: One-comp. (Ketone/Aldehyde) Nominal Titrant Conc.: 5.0000 mg/mL Standardized Titrant Conc.: 5.0000 mg/mL Date/Time: Nov 13, 2018 17:10 Titrant Age Reminder: Disabled				
Select	Escape	Edit	New Titrant	Delete

Press Select if you want to use the selected titrant for the titrant standardization.

Press Escape to return to the **View/Modify Methods** screen.

Press Edit to edit the titrant parameters.

Press New  
Titrant to create a new titrant.

Press Delete to remove the titrant from the database.

KF Titrant Options				
Select the option to be modified.				
<div style="background-color: #e0e0e0; padding: 2px;">Titrant Name: Composite 5</div> Titrant Type: One-comp. (Ketone/Aldehyde) Nominal Titrant Conc. 5.0000 mg/mL Standardized Titrant Conc. 5.0000 mg/mL Titrant Age Reminder: Disabled				
Select	Escape			

Titrant standardization methods supplied by Hanna are designed to work with specific titrant concentrations. The [HI933](#) will automatically select an appropriate titrant when such a method is selected. If there is no usable titrant in the database, a new one will be created.

## 4.5.12.1. TITRANT NAME

Option: up to 15 characters

**Titrant Name**

Select the highlighted letter by using the arrow keys then press <Enter>. Select the empty field for a space. Press <Accept> to save the entire name.

<b>B</b>	C	D	E	F	G	H	I	J	K	L	M	
N	O	P	Q	R	S	T	U	V	W	X	Y	Z
a	b	c	d	e	f	g	h	i	j	k	l	m
n	o	p	q	r	s	t	u	v	w	x	y	z
À	Á	Â	Ã	Ç	È	É	Ê	Ë	Ì	Í	Î	Ï
Ò	Ó	Ô	Õ	à	á	â	ã	ä	å	æ	ç	è
ì	í	î	ï	ò	ó	ô	õ	ö	ü	ú	û	ü
0	1	2	3	4	5	6	7	8	9	%	#	\$
.	,	?	!	(	)	[	]	<	>	=	+	-
*	/	\	_	~	^	'	:	<	>	=	+	-

**Composite 5**

Accept	Escape	Delete Letter	Cursor Left	Cursor Right
--------	--------	---------------	-------------	--------------

## 4.5.12.2. TITRANT TYPE

Options: One-component, One-component (Ketone/Aldehyde), Two-components (Methanol), Two-components (Ethanol) or Others

**Titrant Type**

Select the Karl Fischer titrant type.

<b>One-component</b>
One-comp. (Ketone/Aldehyde)
Two-components, Methanol
Two-components, Ethanol
Others

Select	Escape			
--------	--------	--	--	--

## 4.5.12.3. NOMINAL TITRANT CONCENTRATION

Option: 0.0010 to 20.0000 mg/mL

**Nominal Titrant Conc.**

Enter the nominal titrant concentration.

**5.0000** mg/mL

Low Limit: 0.0010 mg/mL  
High Limit: 20.0000 mg/mL

Accept	Escape	Delete Digit		
--------	--------	--------------	--	--

## 4.5.12.4. STANDARDIZED TITRANT CONCENTRATION

Standardized Titrant Conc.				
Enter the standardized titrant conc.				
5.0000 mg/mL				
Low Limit: 4.0000 mg/mL				
High Limit: 6.0000 mg/mL				
Accept	Escape	Delete Digit		

## 4.5.12.5. TITRANT AGE REMINDER

Option: Off, 0 to 31 days

A programmable reminder will appear when it is time to verify the titrant concentration or to change the titrant.

Titrant Age Reminder				
Enter the time allowed to elapse before the standardization reminder appears.				
days	hours	minutes		
2	00	00		
Press <Next> to move to the next entry.				
Accept	Escape	Delete Digit	Next	

## 4.5.13. CONTROL PARAMETERS

The user can access and edit the parameters related to the titration.

Control Parameters																				
Select the option to be modified.																				
<table border="1"> <tr> <td>Start Mode:</td> <td>Normal</td> </tr> <tr> <td>Imposed Current:</td> <td>20 <math>\mu</math>A</td> </tr> <tr> <td>Dosing Parameters:</td> <td></td> </tr> <tr> <td>Max Dosing Mode:</td> <td>Disabled</td> </tr> <tr> <td>Timed Increment:</td> <td>1 second</td> </tr> <tr> <td>End Point Value:</td> <td>180.0 mV</td> </tr> <tr> <td>Signal Averaging:</td> <td>3 Readings</td> </tr> <tr> <td>Flow Rate:</td> <td>10.0 mL/min</td> </tr> </table>					Start Mode:	Normal	Imposed Current:	20 $\mu$ A	Dosing Parameters:		Max Dosing Mode:	Disabled	Timed Increment:	1 second	End Point Value:	180.0 mV	Signal Averaging:	3 Readings	Flow Rate:	10.0 mL/min
Start Mode:	Normal																			
Imposed Current:	20 $\mu$ A																			
Dosing Parameters:																				
Max Dosing Mode:	Disabled																			
Timed Increment:	1 second																			
End Point Value:	180.0 mV																			
Signal Averaging:	3 Readings																			
Flow Rate:	10.0 mL/min																			
Select	Escape																			

## 4.5.13.1. START MODE

Option: Cautious or Normal

Start Mode														
Select the KF titration start mode.														
<table border="1"> <tr> <td>Cautious</td> <td colspan="4"></td> </tr> <tr> <td>Normal</td> <td colspan="4"></td> </tr> </table>					Cautious					Normal				
Cautious														
Normal														
Select	Escape													

**Cautious:** The titrant dosing begins with the minimum dose in order to prevent over-titration.

**Normal:** The titrant dosing begins with the median value between the minimum and maximum (i.e. minimum dose 5  $\mu\text{L}$ , maximum dose 25  $\mu\text{L}$ , first dose will be 15  $\mu\text{L}$ ).

## 4.5.13.2. IMPOSED CURRENT

Option: 1  $\mu\text{A}$ , 2  $\mu\text{A}$ , 5  $\mu\text{A}$ , 10  $\mu\text{A}$ , 15  $\mu\text{A}$ , 20  $\mu\text{A}$ , 30  $\mu\text{A}$ , or 40  $\mu\text{A}$ Use the  $\triangle$  and  $\nabla$  keys to select the electrode polarization current from the predefined list.

Imposed Current																																												
Choose the imposed current value in $\mu\text{A}$ .																																												
<table border="1"> <tr> <td>1 <math>\mu\text{A}</math></td> <td colspan="4"></td> </tr> <tr> <td>2 <math>\mu\text{A}</math></td> <td colspan="4"></td> </tr> <tr> <td>5 <math>\mu\text{A}</math></td> <td colspan="4"></td> </tr> <tr> <td>10 <math>\mu\text{A}</math></td> <td colspan="4"></td> </tr> <tr> <td>15 <math>\mu\text{A}</math></td> <td colspan="4"></td> </tr> <tr> <td>20 <math>\mu\text{A}</math></td> <td colspan="4"></td> </tr> <tr> <td>30 <math>\mu\text{A}</math></td> <td colspan="4"></td> </tr> <tr> <td>40 <math>\mu\text{A}</math></td> <td colspan="4"></td> </tr> </table>					1 $\mu\text{A}$					2 $\mu\text{A}$					5 $\mu\text{A}$					10 $\mu\text{A}$					15 $\mu\text{A}$					20 $\mu\text{A}$					30 $\mu\text{A}$					40 $\mu\text{A}$				
1 $\mu\text{A}$																																												
2 $\mu\text{A}$																																												
5 $\mu\text{A}$																																												
10 $\mu\text{A}$																																												
15 $\mu\text{A}$																																												
20 $\mu\text{A}$																																												
30 $\mu\text{A}$																																												
40 $\mu\text{A}$																																												
Select	Escape																																											

**Note:** Higher polarization currents will speed the contamination of the electrode and potentially degrade samples.

## 4.5.13.3. DOSING PARAMETERS

Option: 0.125 to 4000  $\mu\text{L}$ 

Dosing Parameters				
Enter the minimum and maximum dose.				
0.5000 $\mu\text{L}$ - min Vo1				
40.000 $\mu\text{L}$ - max Vo1				
Press <Next> to move to the next entry.				
Accept	Escape	Delete Digit	Next	

## 4.5.13.4. MAXIMUM DOSING MODE

Option: Disabled or Enabled

When enabled, the titrator will use a dosing algorithm which ensures a faster titration by changing the dosing mode if the mV is far from the end point.

The algorithm will use maximum dosing if the difference between mV value and end point is higher than 150 mV.

Disable this option if higher accuracy is desired.

Max Dosing Mode				
Select the option for max dosing mode.				
<div style="border: 1px solid black; padding: 2px;">           Disabled  <b>Enabled</b> </div>				
Select	Escape			

#### 4.5.13.5. TIMED INCREMENT

Use the  $\triangle$  and  $\nabla$  keys to enter the period of time between two successive doses.

Timed Increment				
Choose the period for wait time up to the next dose dispensing.				
0.5 seconds				
1 second				
2 seconds				
3 seconds				
4 seconds				
5 seconds				
Select	Escape			

#### 4.5.13.6. END POINT VALUE

**Option: 5.0 to 600.0 mV**

Use the numeric keypad to enter the mV value at which the titration equivalence point (end point) has been reached. This value is also used to determine when the pre-titration is complete.

End Point Value				
Enter the potential value representing the end point of the titration.				
180.0 mV				
Low Limit: 5.0 mV				
High Limit: 600.0 mV				
Accept	Escape	Delete Digit		

## 4.5.13.7. SIGNAL AVERAGING

**Option: 1 to 10 readings**

The titrator will take the last reading and place it into a “moving window” along with the last 2, 3, etc readings (depending on selected option). The average of these readings is displayed and used for calculations. Averaging more readings is helpful when a noisy signal is received from the electrode.

If 1 reading is selected this option is disabled.

Signal Averaging														
Select the number of readings to be averaged.														
<table border="1"> <tbody> <tr><td>1 Reading</td></tr> <tr><td>2 Readings</td></tr> <tr><td><b>3 Readings</b></td></tr> <tr><td>4 Readings</td></tr> <tr><td>5 Readings</td></tr> <tr><td>6 Readings</td></tr> <tr><td>7 Readings</td></tr> <tr><td>8 Readings</td></tr> <tr><td>9 Readings</td></tr> <tr><td>10 Readings</td></tr> </tbody> </table>					1 Reading	2 Readings	<b>3 Readings</b>	4 Readings	5 Readings	6 Readings	7 Readings	8 Readings	9 Readings	10 Readings
1 Reading														
2 Readings														
<b>3 Readings</b>														
4 Readings														
5 Readings														
6 Readings														
7 Readings														
8 Readings														
9 Readings														
10 Readings														
Select	Escape													

## 4.5.13.8. FLOW RATE

**Option: 0.3 to 10.0 mL/min (for 5 mL burette)**

Flow Rate						
Enter the titrant flow rate.						
<table border="1"> <tbody> <tr> <td style="width: 100px;">5.0</td> <td>mL/min</td> </tr> </tbody> </table>					5.0	mL/min
5.0	mL/min					
Low Limit: 0.3 mL/min High Limit: 10.0 mL/min						
Accept	Escape	Delete Digit				

**Note:** The titrator will automatically detect the burette size and display the correct high limit volume.

The flow rate is set for all burette operations.

#### 4.5.14. TERMINATION PARAMETERS

This screen allows the user to set the control parameters related to titration termination.

Termination Parameters												
Select the option to be modified.												
<table border="1"> <tr> <td>Maximum Duration:</td> <td>1200 sec</td> </tr> <tr> <td>Maximum Titrant Volume:</td> <td>10.000 mL</td> </tr> <tr> <td>Termination Criterion:</td> <td>Relative Drift</td> </tr> <tr> <td>Relative Drift:</td> <td>7.0 µg/min</td> </tr> </table>					Maximum Duration:	1200 sec	Maximum Titrant Volume:	10.000 mL	Termination Criterion:	Relative Drift	Relative Drift:	7.0 µg/min
Maximum Duration:	1200 sec											
Maximum Titrant Volume:	10.000 mL											
Termination Criterion:	Relative Drift											
Relative Drift:	7.0 µg/min											
Select	Escape											

##### 4.5.14.1. MAXIMUM DURATION

**Option: 10 to 3600 seconds**

If the titration end point is not reached, the titration will be terminated after the maximum duration. The error message "Value Out of Range" will appear on the display.

Maximum Duration				
Enter the time period after the titration is automatically stopped.				
<p style="text-align: center;">1200 seconds</p>				
Low Limit: 10 seconds High Limit: 3600 seconds				
Accept	Escape	Delete Digit		

#### 4.5.14.2. MAXIMUM TITRANT VOLUME

Option: 0.100 to 50.000 mL

The maximum titrant volume used in the titration must be set according to the analysis. If the titration end point is not reached, the titration will be terminated after the maximum titrant volume has been dispensed. The error message ("Limits Exceeded") will appear on the display.

Maximum Titrant Volume				
Enter the maximum titrant volume to be dispensed.				
10.0000 mL				
Low Limit: 0.100 mL				
High Limit: 50.000 mL				
Accept	Escape	Delete Digit		

#### 4.5.14.3. TERMINATION CRITERION

Option: mV End Point, Absolute Drift or Relative Drift

Termination Criterion							
Select titration termination criterion.							
<table border="1" style="width: 100%;"> <tr> <td>mV End Point</td> </tr> <tr> <td>Absolute Drift</td> </tr> <tr> <td>Relative Drift</td> </tr> </table>					mV End Point	Absolute Drift	Relative Drift
mV End Point							
Absolute Drift							
Relative Drift							
Select	Escape						

**mV End Point** The titration is terminated when the potential remains below a set end point value for a specified period of time.

**Absolute Drift** The titration is terminated when the actual drift is less than the predefined absolute drift value.

**Relative Drift** The titration is terminated when the actual drift is less than the sum between the initial drift and the predefined relative drift.

#### 4.5.14.4. END POINT STABILITY TIME

Option: 1 to 30 seconds

The potential must remain below the set end point value for the specified period of time.

<p><b>End Point Stability Time</b></p> <p>Enter the time period necessary to validate the titration end point.</p> <p style="text-align: center;">4 seconds</p> <p>Low Limit: 1 seconds High Limit: 30 seconds</p>				
Accept	Escape	Delete Digit		

#### 4.5.14.5. ABSOLUTE DRIFT

Option: 0.0 to 40.0  $\mu\text{g}/\text{min}$

<p><b>Absolute Drift</b></p> <p>Enter the drift value to be used by the termination criterion.</p> <p style="text-align: center;">15.0 <math>\mu\text{g}/\text{min}</math></p> <p>Low Limit: 0.0 <math>\mu\text{g}/\text{min}</math> High Limit: 40.0 <math>\mu\text{g}/\text{min}</math></p>				
Accept	Escape	Delete Digit		

#### 4.5.14.6. RELATIVE DRIFT

Option: 0.0 to 40.0  $\mu\text{g}/\text{min}$

<p><b>Relative Drift</b></p> <p>Enter the drift value to be used by the termination criterion.</p> <p style="text-align: center;">15.0 <math>\mu\text{g}/\text{min}</math></p> <p>Low Limit: 0.0 <math>\mu\text{g}/\text{min}</math> High Limit: 40.0 <math>\mu\text{g}/\text{min}</math></p>				
Accept	Escape	Delete Digit		

#### 4.5.15. RESULT UNIT

Option: %, ppm, mg/g,  $\mu\text{g/g}$ , mg,  $\mu\text{g}$ , mg/mL or  $\mu\text{g/mL}$

Result Unit				
Select the unit for your results.				
<div style="border: 1px solid black; padding: 5px;">           %            ppm            mg/g  <math>\mu\text{g/g}</math>            mg  <math>\mu\text{g}</math>            mg/mL  <math>\mu\text{g/mL}</math> </div>				
Select	Escape			

#### 4.5.16. SIGNIFICANT FIGURES

Option: Two (XX), Three (XXX), Four (XXXX) or Five (XXXXX)

This option allows you to set the format for displaying the final titration result.

Significant Figures				
Choose the format for your result.				
<div style="border: 1px solid black; padding: 5px;">           XX            XXX            XXXX            XXXXX         </div>				
Select	Escape			

#### 4.6. PRINTING

To print method parameters, press Method Options from the main screen.

Press Print Method and wait a few seconds until the printer completes the job.

If no printer is connected to the dedicated socket, or if the printer is offline, an error message will appear on the display (see [Connecting a Printer](#) section, for details on connecting a printer to the titrator).

## 5. TITRATION MODE

### 5.1. IDLE

The titrator first enters Idle mode when it is switched on. All of the HI933's software features and settings can be accessed from the Idle mode. This includes all of the user-adjustable method parameters, solvent handling system, file transfers, calibration checks, software upgrades, options for interface with PC and accessories as well as burette options. To access the titration menu (*Process screen*) press .

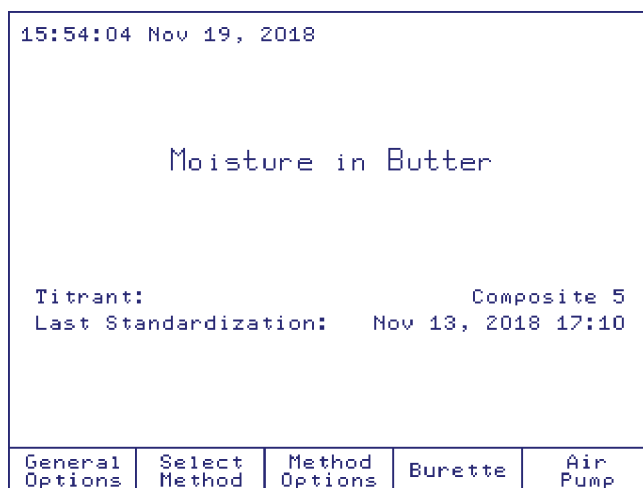

The titration (Sample Analysis or Titrant Standardization) is performed with the selected method. Be sure that the selected method is customized in accordance with the specifics of the application.

Before performing a titration make sure that the following conditions are met:

- All of the attached systems (e.g.: solvent system) are properly assembled.
- The right amount of solvent is present in the beaker (between the min and max marks) for best reproducibility.

The following intermediary stages are performed automatically before starting the titration:

- **Solvent pre-titration**
- **Drift analysis (Automatic Determination Entry only)**

When the drift analysis process is finished, the titrator enters **Standby** mode. At this point, a titration can be initiated.

## 5.2. PRE-TITRATION

In pre-titration, the residual water on the interior surface of the titration vessel, the water contained in the entrapped air and the small amount of water from the solvent is eliminated.

The HI933 reacts residual water by adding titrant until the specified endpoint potential is reached. This setting is associated with the selected method. After the electrode potential has stabilized, the titrator moves into the Drift Rate Determination Stage.

When the pre-titration is started, the stirrer is automatically turned on and the user cannot change the selected method or access the method parameters.

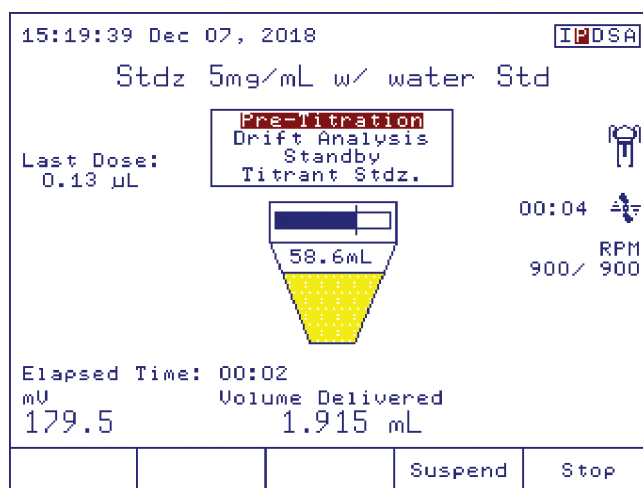

**Note:** If the pre-titration lasts longer than 30 minutes the titrator switches to Idle mode. Errors may have occurred in your titration system (beaker is not properly sealed, wrong or missing titrant, unconnected or bad electrode, etc.). Check the system and start the pre-titration again.

## 5.3. DRIFT ANALYSIS (AUTOMATIC DETERMINATION ENTRY ONLY)

While in this mode the HI933 conducts a one minute analysis which determines the amount of moisture leaking into the cell from the atmosphere. Despite the titration vessel being tightly sealed, water will still seep into the cell. The amount of water that migrates into the cell per unit time is known as the background drift rate, or the drift rate.

The drift rate is determined by keeping track of the number of very small, successive doses of titrant required to maintain the 'dryness' of the solvent over the course of a minute. The rate at which water leaks into the cell is then calculated and reported by the HI933 in units of  $\mu$ g/min.

The HI933 will automatically subtract the drift rate from the titration results. This is important for titration accuracy when analyzing samples with very low water content, where the amount of water that has leaked into the cell is a considerable fraction of the total water titrated during the analysis.

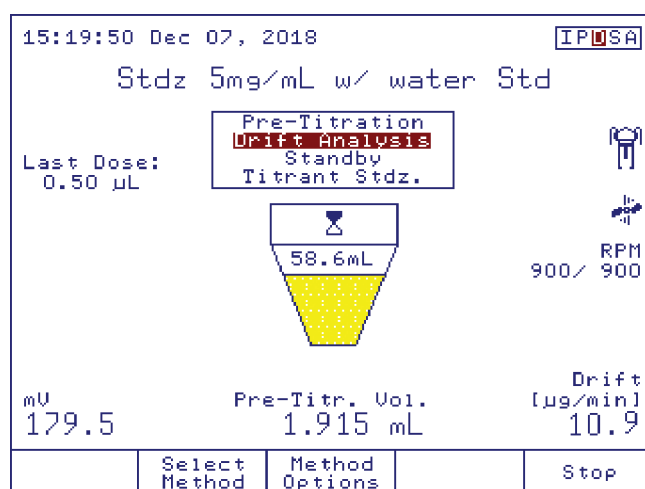

When the drift becomes stable the titrator switches to **Standby** mode.

During the drift analysis, if the titrator cannot maintain cell dryness, the titrator reverts to pre-titration.

**Note:** If the drift entry mode is set as Manual Entry the drift analysis stage is skipped.

#### 5.4. STANDBY

After the drift rate has been determined, the HI933 moves into **Standby** mode. In standby mode the dryness of the titration cell is maintained and the drift rate is continuously monitored and updated.

From **Standby** mode a sample analysis, titrant standardization or drift rate logging session can be started as well as method selection, customization of method parameters, and general options (external keyboard only, by pressing <<Home>>).

After an initial titrator setup and prior to the first titration or standardization, the drift rate should be allowed to settle in **Standby** mode for 45 min. This ensures that the drift rate is stable and reflects the actual rate at which water vapor is entering the cell rather than representing a slow drying of the air between the solvent and the top of the cell. The stabilization can be verified by examining the drift rate vs. time curve which can only be accessed from standby mode.

During standby, if the drift becomes unstable, the titrator will switch back to Drift Analysis mode.

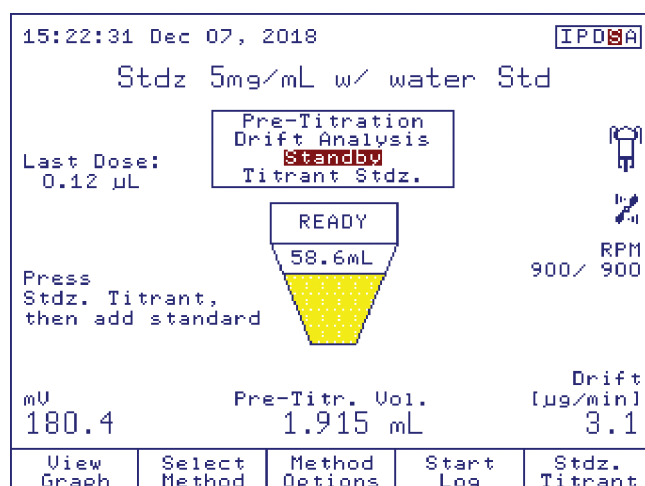



## 5.5. SAMPLE ANALYSIS

While in **Standby** mode, press .

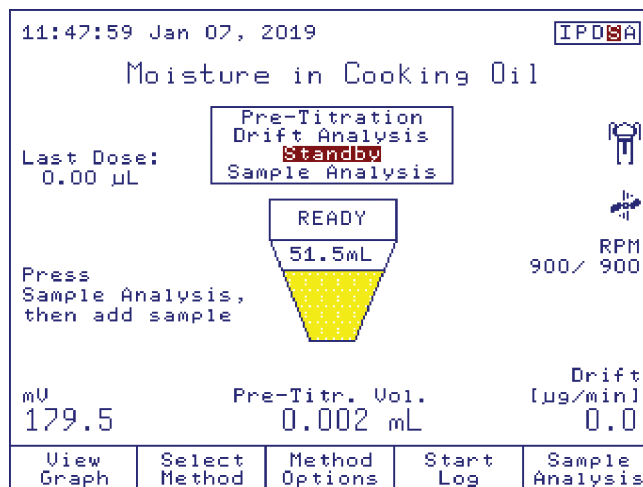
*Note: If the drift value is zero, a warning message appears to inform the user that the solvent may be overtitrated.*



The user can choose to continue the titration by pressing  or to return to Standby mode by pressing  in order to wait until the drift is stabilized at a higher value.

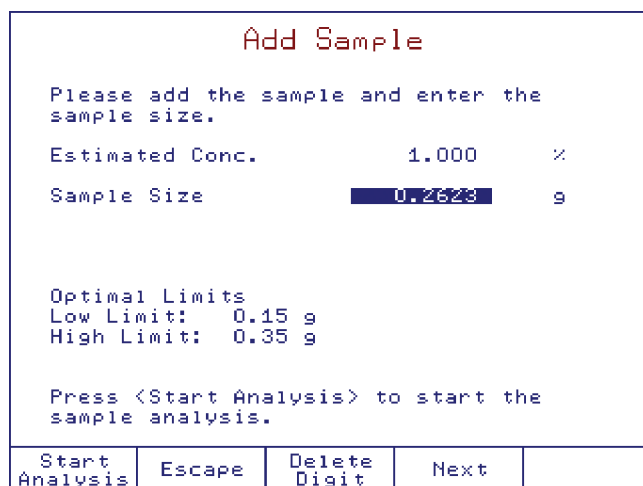

If necessary, update the estimated concentration. This value is used to determine the pre-titration volume. The optimal limits will be updated based on this value.

Follow the steps below to add the sample to the titration vessel and determine the sample size.

### 5.5.1. SAMPLE SIZE

#### 5.5.1.1. MANUAL ENTRY

##### 5.5.1.1.1. SAMPLE SIZE BY MASS

- 1) Measure the mass of the sample in a weigh boat or syringe.
- 2) Remove the sample plug from the top of the beaker to open the sample port, or insert the syringe needle through the septum.
- 3) Rapidly add the sample through the sample port or through the septum. Pay attention not to get any sample on the electrode or beaker wall.
- 4) Replace the sample plug or remove the syringe from the septum.

- 5) Determine the mass of the 'empty' weigh boat or syringe.
- 6) Calculate the mass of the sample added (subtract the mass of the emptied weigh boat or syringe from the mass of the full weigh boat or syringe).
- 7) Enter the calculated mass of the sample.

#### 5.5.1.1.2. SAMPLE SIZE BY VOLUME

- 1) Attach a long needle (approximately 6 cm for best control) to a precision-volume syringe large enough to hold at least one complete sample volume.
- 2) Rinse the syringe and needle with sample several times by drawing in a small portion of sample, fully extending the plunger, shaking to coat the syringe interior and expelling the sample into a waste collection container.
- 3) Draw enough sample into the syringe for at least one titration.
- 4) Dry the outside of the needle with a lint free wipe or tissue.
- 5) Insert the needle through the septum in the sample port. Push the syringe through the septum until the end of the needle is approximately 1 cm from the surface of the solvent.
- 6) Steadily dispense the appropriate volume of sample ensuring that the sample is introduced directly into the solvent and does not splash or spatter onto the wall of the titration vessel, electrode, or dispensing tip.
- 7) Draw a small amount of air from inside the cell into the syringe to ensure that no sample drops remain on the tip of the needle.
- 8) Remove the syringe and needle from the septum taking care to not touch the needle to the solvent or other internal cell components.
- 9) Enter the volume of the sample.

#### 5.5.1.1.3. SAMPLE SIZE BY PIECES

- 1) Remove the sample plug from the beaker top to open the sample port.
- 2) Use a gloved hand, tweezers, or a weigh boat to add the appropriate number of pieces to the titration vessel.
- 3) Replace the sample plug.
- 4) Enter the number of pieces that were added to the titration vessel.

#### 5.5.1.2. AUTOMATIC MASS ACQUISITION FROM ANALYTICAL (SAMPLE SIZE BY MASS ONLY)

The sample size can be automatically acquired from the balance when connected to the titrator using the RS232 interface.

Sample Weighing				
Balance: Default				
Initial Weight: 0.2302 g				
Final Weight: -----				
Put weighing boat on the balance.				
Press <Accept> to update weight.				
Accept	Escape		Balance Setup	

## 5.5.2. PROCEDURE

- 1) Place the syringe or the weigh boat containing the sample on the balance.
- 2) Wait until the reading has stabilized and press .
- 3) Add the sample in the titrator vessel.
- 4) Place the empty syringe or weigh boat on the balance.

Sample Weighing				
Balance: Default				
Initial Weight: 0.2302 g				
Final Weight: 0.0157 g				
Put empty weighing boat on the balance.				
Press <Accept> to update weight.				
Accept	Escape		Balance Setup	

- 5) Wait for the reading to stabilize and press .
- The titrator returns to the previous screen and the sample size is automatically updated.

Add Sample				
Please add the sample and enter the sample size.				
Estimated Conc. 1.000 x				
Sample Size <b>0.2145</b> g				
Optimal Limits				
Low Limit: 0.15 g				
High Limit: 0.35 g				
Press <Start Analysis> to start the sample analysis.				
Start Analysis	Escape	Delete Digit	Next	

Press  to begin the analysis.

**Note:** The user must make sure that the balance and the titrator are properly configured and the balance feature is enabled (see **Setup Balance Interface**).

### 5.5.3. SAMPLE ANALYSIS

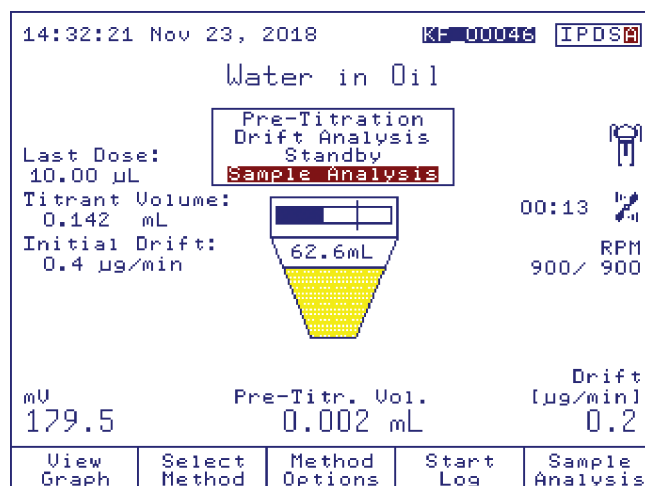

Press  to stop the titration manually and return to the Idle mode.

Press  to stop the titration and return to **Standby** mode.

### 5.5.4. SUSPEND TITRATION

While the titration is in progress, you can temporarily stop it by pressing . The burette will stop dispensing titrant.

To continue the titration, press .

### 5.5.5. VIEWING THE TITRATION CURVE

During a titration, the titration curve can be displayed on the **Titration Graph** screen, by pressing . The titration ID report is also displayed inside the graph window.

### 5.5.6. RESULTS

When the end point is reached the titration is finished and the following screen is displayed.

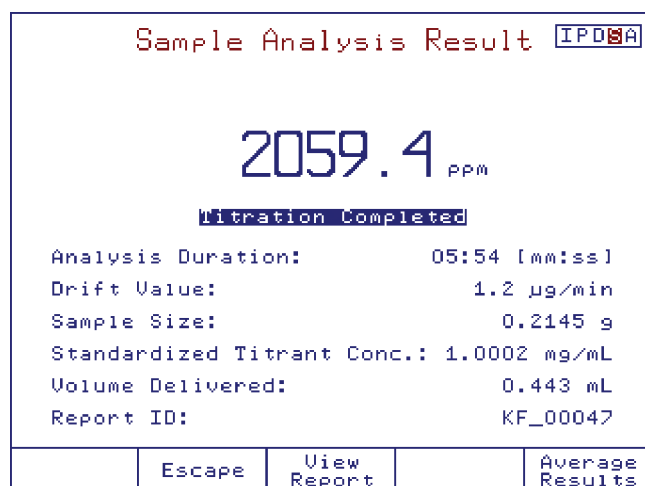

This screen displays information about the titration (duration, drift value used for compensation, sample size, titrant concentration, dispensed titrant volume, titration report ID).

Press  to see the titration report.

Review Result				
KF_00046.RPT				
HI933 - Titration Report				
Method Name:	Water in Oil			
Time & Date:	14:32 Nov 23, 2018			
Titration ID:	KF_00046			
Nr	Volume[ml]	mV	Time	
0	0.0000	562.1	00:00:00	
1	0.0000	562.1	00:00:01	
2	0.0010	562.0	00:00:03	
3	0.0030	559.9	00:00:05	
4	0.0070	554.5	00:00:08	
5	0.0150	549.9	00:00:10	
View Graph	ESCAPE	Print Report	Page Up	Page Down

Press  to see the titration graph.

Press  to print the report.

### 5.5.7. SAMPLE ANALYSIS HISTORY

By pressing , results will be added to the Sample Analysis History in order to obtain an average of titration results.

Use the  and  keys to scroll the results list.

Use  to choose the samples that will be used for averaging.

Sample Analysis History		
Date/Time	Sample Conc.[ppm]	
* Nov 23, 2018 14:32	2149.2	
* Nov 23, 2018 14:50	2159.3	
* Nov 23, 2018 14:05	2132.3	
Standardized Titrant Conc.: 1.0002 mg/mL		
Sample Size: 0.2145 g		
Average Sample Conc.: 2146.9 ppm		
Standard Deviation: 13.6675 ppm		
Unselect.	Escape	Delete

**Note:** When there are no results selected, dashes will appear in the Average Sample Concentration and the Standard Deviation fields.

## 5.6. TITRANT STANDARDIZATION

While in **Standby** mode, press .

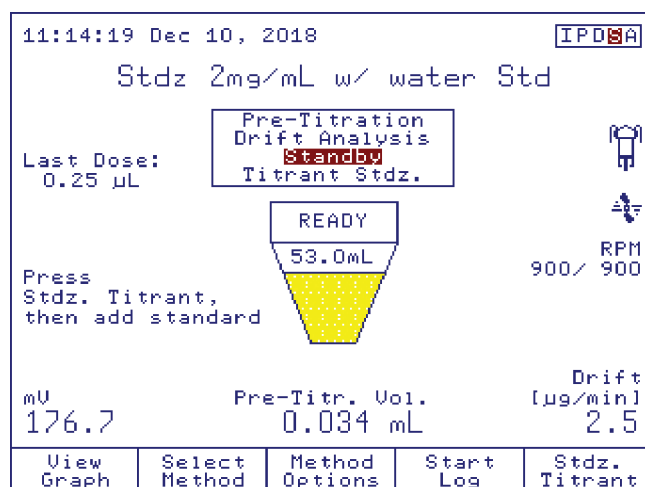

11:14:19 Dec 10, 2018 IPD SA

Stdz 2mg/mL w/ water Std

Pre-Titration Drift Analysis  
Standby  
Titrant Stdz.

Last Dose:  
0.25 uL

Press  
Stdz. Titrant,  
then add standard

READY  
53.0mL

RPM  
900 / 900

mU 176.7 Pre-Titr. Vol. 0.034 mL Drift [ug/min] 2.5

View Graph Select Method Method Options Start Log Stdz. Titrant

**Note:** If the drift value is zero, a warning message appears to inform the user that the solvent may be overtitrated.

### 5.6.1. ADDING THE STANDARD

The user must add the standard into the beaker and enter the standard size. The units of sample size are determined by the method setting.

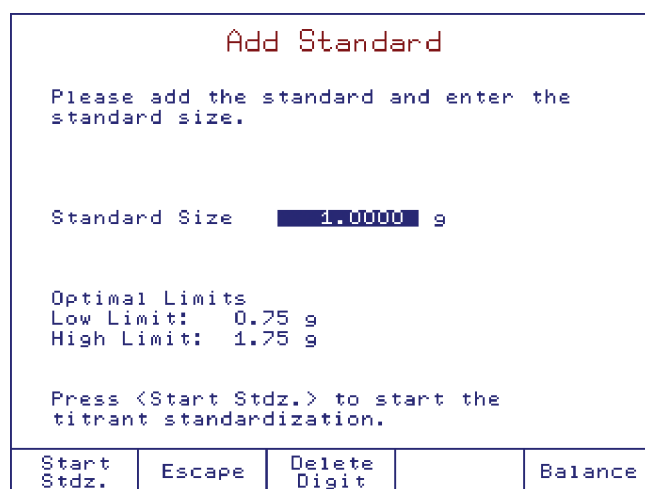

Add Standard

Please add the standard and enter the standard size.

Standard Size 1.0000 g

Optimal Limits  
Low Limit: 0.75 g  
High Limit: 1.75 g



Press <Start Stdz.> to start the titrant standardization.

Start Stdz. Escape Delete Digit Balance

Follow the same procedure as for adding samples (see [Sample Analysis](#)).

## 5.6.2. START STANDARDIZATION

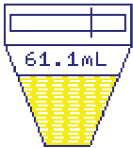
Press  to begin standardization.

11:52:02 Dec 10, 2018		KF-00028		IPDS	
Stdz 2mg/mL w/ water Std					
Last Dose: 0.00 µL		Pre-Titration Drift Analysis Standby <b>Titrant Stdz.</b>			
Titrant Volume: 0.011 mL					
Initial Drift: 2.2 µg/min				RPM 900/ 900	
Elapsed Time: 00:10		mU 698.4		Drift [µg/min]	
		<b>In Progress</b>		----- mg/mL	
View Graph				Suspend	
				Stop	

**Note:** During titrant standardization the user has the same options as a sample analysis (see [Sample Analysis](#)).

When the titrant standardization is finished the user has two options to update the titrant concentration:

By pressing  the titrant is updated with the current result.

By pressing  the user can average the titrant concentration using more results.

Standardization Result					IPDS
<b>2.2290</b> mg/mL					
<b>Titration Completed</b>					
Analysis Duration:		04:36 [mm:ss]			
Drift Value:		1.7 µg/min			
Standard Size:		2.9210 g			
Standard Concentration:		0.9970 mg/g			
Volume Delivered:		1.310 mL			
Report ID:		KF_00084			
Escape		View Report		Update Titrant	
				Average Results	

### 5.6.3. AVERAGING TITRANT STANDARDIZATION RESULTS

By pressing  results can be added to the sample analysis history in order to obtain an average of titrant concentration.

Titrant Standardization History			
Date/Time	Titer[mg/mL]		
* Dec 10, 2018 12:40	2.2001		
* Dec 10, 2018 12:46	2.2290		
Standard Water Content: 0.9970 mg/g			
Standard Size: 2.9210 g			
Average Titer: 2.2145 mg/mL			
Standard Deviation: 0.0204 mg/mL			
Unselect	Escape	Update Titrant	Delete

Use the  and  keys to scroll the concentration results list.

Use  to choose the titrant concentration results that will be used for averaging.

Press  to update the concentration with the current average.

**Note:** When there are no results selected, dashes will appear in the average titrant concentration and the standard deviation fields.  is not available.

## 6. AUXILIARY FUNCTIONS

### 6.1. AIR PUMP

The air pump is used to add or remove the solvent in the titration beaker without exposure to atmospheric moisture.

To enter **Air Pump** screen, press  from the Idle screen.

#### 6.1.1. FILLING THE BEAKER

To add solvent to the titration beaker:

- 1) Press  from the **Air Pump** screen, the air pump will start and solvent will be added to the beaker. If the solvent is not flowing or is flowing very slowly, verify that the bottle top assemblies are properly assembled and tightly sealed and that the liquid handling tubing reaches the bottom of the solvent bottle.

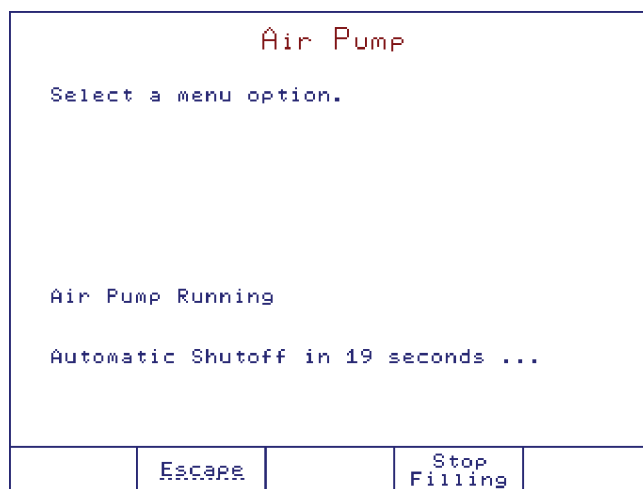

- 2) When the level of solvent inside the titration cell reaches the "Min" indicator line, press  to turn off the air pump. If  is not pressed, the air pump will automatically shut off after 20 seconds.
- 3) The **HI933** will prompt the user to verify that the titration cell has been filled to the "Min" line (approx. 50 mL). Press  to return to the Idle screen.

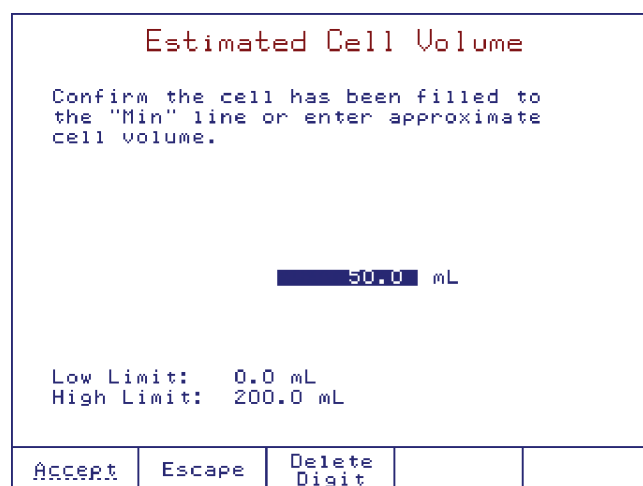

### 6.1.2. EMPTYING THE BEAKER

To remove the waste from the titration beaker:

- 1) Loosen the waste tube fitting slightly and slide the waste tube down until it reaches the bottom of the beaker.
- 2) From the **Air Pump** screen, press **Start Emptying** and allow the air pump to run until all of the waste has been removed.
- 3) Press **Stop Emptying** to turn off the air pump. If **Stop Emptying** is not pressed, the air pump will automatically shut off after 60 seconds.
- 4) Return the waste tube back into its original position and re-tighten the fitting.

### 6.2. BURETTE

To access the **Burette** screen, press **Burette** from the Idle screen.

Highlight the desired option and then press **Select**.

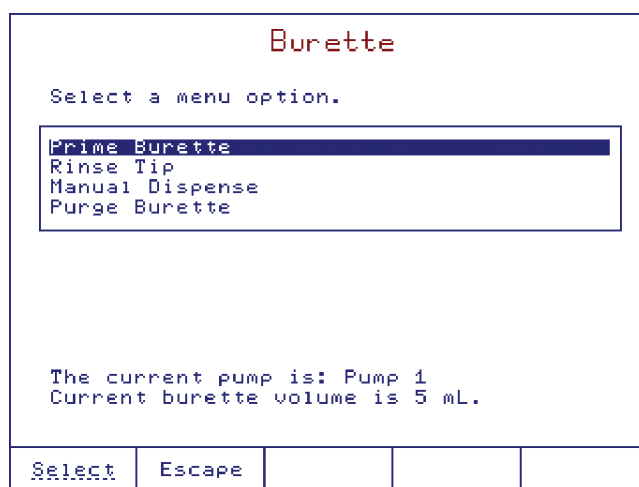

**Note:** Do not perform burette functions with solvent below the “Min” sign. Doing so could spray titrant on the beaker top or other components.

#### 6.2.1. PRIMING THE BURETTE

After solvent has been added to the titration cell, the burette can be primed with titrant. The priming process consists of several cycles of filling and emptying the burette with titrant. It ensures that any air, water or water vapor in the burette or tubing is removed.

Two rinse cycles of burette are shown in the figure below. The dispensing tube is connected on the right side and the aspiration tube on the left side.

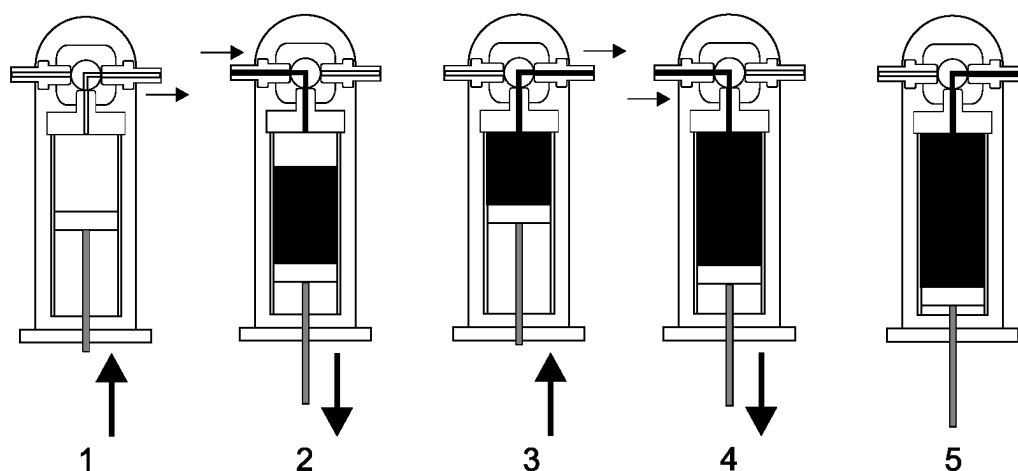

**Note:** Before starting this operation, the aspiration tube must be inserted into the titrant bottle.

To prime the burette, select *Prime Burette* from the **Burette** screen. Enter the number of rinses and press . The number of burette rinses can be set between 1 and 5 (we recommend at least three rinses to assure that the air bubbles are completely removed).

Total Burette Rinses				
Enter the total number of burette rinses.				
<div style="border: 1px solid black; display: inline-block; padding: 2px 10px;">3</div>				
A minimum of three rinses is recommended.				
Accept	Escape	Delete Digit		

### 6.2.2. RINSING TIP

A 0.25 mL dose of titrant will be dispensed from the burette when this operation is selected. This operation will eliminate any contamination from the anti-diffusion dispensing tip.

### 6.2.3. MANUAL DISPENSE

**Option: 0.000125 to 4.750 mL (5 mL Burette)**

*Manual Dispense* allows a defined titrant volume to be dosed. Select the *Manual Dispense* option and press . The **Manual Volume Dispense** screen will become active and the display will prompt you to enter the desired volume to be dispensed.

Manual Volume Dispense				
Enter the volume to be dispensed.				
<div style="border: 1px solid black; display: inline-block; padding: 2px 10px;">1.000 mL</div>				
Current burette volume is 5 mL.				
Accept	Escape	Delete Digit		

### 6.2.4. PURGING BURETTE

This option allows the burette to be emptied before cleaning and/or storing.

**Note:** Before starting this operation, remove the aspiration tube from the titrant bottle.

The figures below show the steps in a purge burette operation.

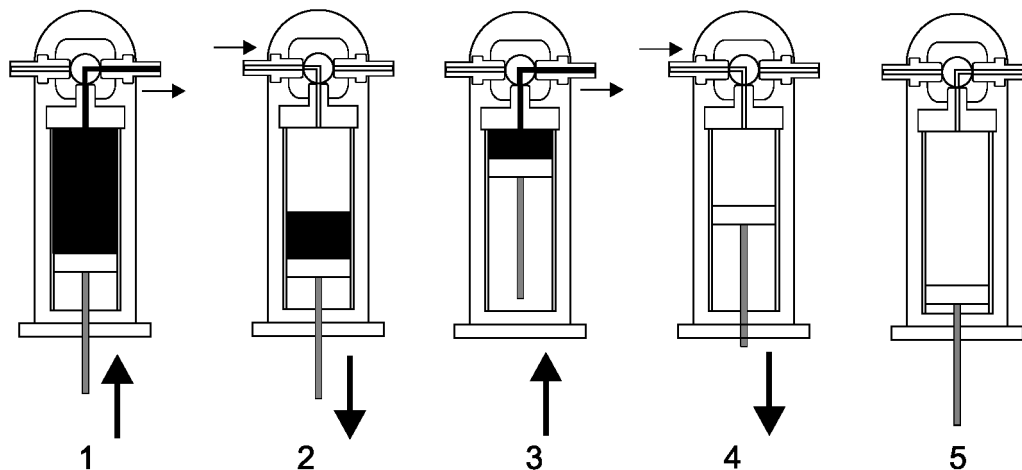

### 6.3. STIRRER

**Note:** When custom stirrer is selected (see [General Options](#) section), the commands related to the stirrer are not available.

In Idle mode the stirrer can be turned on and off by pressing .

During the titration process, the stirring speed can be manually adjusted by using the  and  keys.

**Note:** The stirrer can not be turned off during the titration process.

### 6.4. RESULTS

To access the **Data Parameters** screen, press .

From the **Data Parameters** screen you can access the following options:

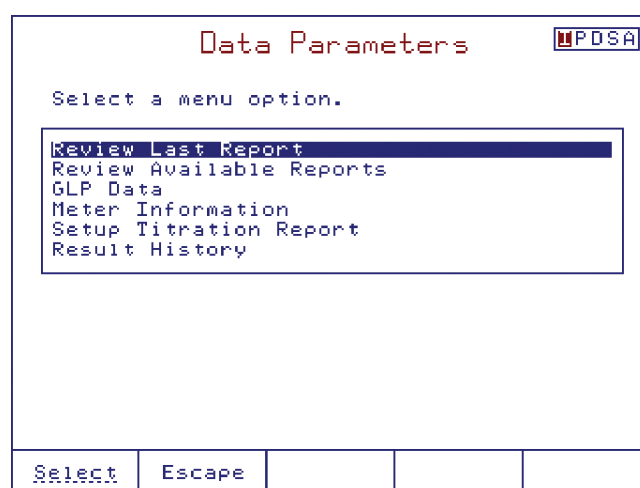

### 6.4.1. REVIEWING LAST REPORT

The last titration report can be reviewed.

Review Result				
KF_00046.RPT				
HI933 - Titration Report				
Method Name:	Water in Oil			
Time & Date:	14:32 Nov 23, 2018			
Titration ID:	KF_00046			
Nr	Volume[m1]	mU	Time	
0	0.0000	562.1	00:00:00	
1	0.0000	562.1	00:00:01	
2	0.0010	562.0	00:00:03	
3	0.0030	559.9	00:00:05	
4	0.0070	554.5	00:00:08	
5	0.0150	549.9	00:00:10	
View Graph	Escape	Print Report	Page Up	Page Down

The information seen in the report is based on the selections made in the **Setup Titration Report** screen.

The following option keys are available:

View Graph	Review the titration graph.
Print Report	Print the titration report.
Escape	Return to the previous screen.
Page Up	Page Down
Keys can be used to scroll through the pages.	

### 6.4.2. REVIEWING AVAILABLE REPORTS

Up to 100 reports can be saved on the titrator. To view one of the saved reports highlight a report and then press

View Report

Available Reports				
Highlight a report & press <View Report> to see the detailed data.				
Water in Oil	ID:KF_00047			
Titration Report	14:50 Nov 23, 2018			
Water in Oil	ID:KF_00046			
Titration Report	14:32 Nov 23, 2018			
Water in Oil	ID:KF_00045			
Titration Report	14:22 Nov 23, 2018			
Water in Oil	ID:KF_00044			
Titration Report	11:13 Nov 23, 2018			
Water in Oil	ID:KF_00043			
Titration Report	11:02 Nov 23, 2018			
Drift Report	ID:DR_00042			
Hydranal Comp. 5 Stdz .	07:04 Nov 23, 2018			
Titration Report	ID:KF_00041			
Titration Report	16:29 Nov 21, 2018			
View Graph	Escape	View Report	Print Report	Delete Report

The report contains only the information selected in the **Setup Titration Report** screens during report generation.

The following option keys are available:

View Graph	Review the selected graph.
View Report	Review the selected report.
Print Report	Print the selected report.
Delete Report	Delete the selected report.
Escape	Return to the previous screen.

### 6.4.3. GLP DATA

Option: Up to 20 characters

GLP Data																
Select a menu option.																
<table border="1"> <tr> <td>Company Name:</td> <td></td> </tr> <tr> <td>Operator Name:</td> <td></td> </tr> <tr> <td>Electrode Name:</td> <td></td> </tr> <tr> <td>Field 1:</td> <td></td> </tr> <tr> <td>Field 2:</td> <td></td> </tr> <tr> <td>Field 3:</td> <td></td> </tr> </table>					Company Name:		Operator Name:		Electrode Name:		Field 1:		Field 2:		Field 3:	
Company Name:																
Operator Name:																
Electrode Name:																
Field 1:																
Field 2:																
Field 3:																
Select	Escape															

**Company Name:** Allows the company name to be recorded in each report.

**Operator Name:** Allows the operator name to be recorded in each report.

**Electrode Name:** Allows the electrode name to be recorded in each report.

**Fields 1, 2, 3:** Allows any additional information to be recorded in each report.

The fields must be selected from the **Setup Titration Report** screen (see [Setup Titration Report](#)) in order to be displayed in the titration report.

### 6.4.4. METER INFORMATION

Displays titrator configuration data.

Meter Information				
HI 933 Karl Fischer Volumetric Titrator				
SERIAL NUMBER				
Titrator Serial Number:	101290016102			
Analog Board Serial Number:	201290016102			
Pump Serial Number:	401280013101			
Stirrer Serial Number:	601260103101			
SOFTWARE VERSION				
Titrator Software Version:	v1.0			
Base Board Software Version:	v1.0			
Pump Software Version:	v1.0			
Stirrer Software Version:	v1.0			
RESOURCES VERSION				
String Resources Version:	v1.0			
Menu Resources Version:	v1.0			
Error Resources Version:	v1.0			
Help Resources Version:	v1.0			
Analog Calibration Date:	Oct 18, 2018			
	Escape	Print		

**Titrator Serial Number:** The serial number of the titrator base board.

**Analog Board Serial Number:** The serial number of the titrator analog board.

**Stirrer Serial Number:** The serial number of the stirrer.

**Stirrer Software Version:** The current software version of the stirrer.

**Titrator Software Version:** The current software version installed on the titrator.

**Base Board Software Version:** The current software version present on the base board of the titrator.

**Analog Calibration Date:** Manufacturer calibration date of analog board.

**Resources Version:** The current of the text resources.

**Note:** If more than 1 year elapsed from the calibration date of the analog board, the message **Analog Calibration Due** will appear on the main screen and analog board recalibration must be performed.

### 6.4.5. SETTING UP TITRATION REPORT

Customize a unique report to record the titration results. An asterisk means that it will be included in the titration report.

Set Up Titration Report

Select fields to be saved in the report.

- \* Result and Units
- \* Titration Method
- \* Standard/Sample Size
- \* End Point Volume
- \* Titration Duration
- \* Date and Time
- \* Titration Ended By
- \* All Data Points
- \* Method Parameters

- Company Name
- Operator Name
- Electrode Name
- Field 1
- Field 2

Unselect	Escape	Save Report	Page Up	Page Down
----------	--------	-------------	---------	-----------

- Select Adds the highlighted information to the report.
- Unselect Removes the highlighted information from the report.
- Escape Returns to the **Data Parameter Screen**. Report is not updated.
- Save Report Update the report with the select items. Report previously saved will not be updated.
- Page Up Page Down Scroll through the options.

### 6.4.6. RESULT HISTORY

This option allows the user to access the sample analysis history and average the titration results.

Use the ▲ and ▼ keys to scroll the results list.

Use Select to choose the samples that will be used for averaging.

Sample Analysis History

Date/Time	Sample Conc.[ppm]
* Nov 23, 2018 14:32	2149.2
* Nov 23, 2018 14:50	2159.3
* Nov 23, 2018 14:05	2132.3

Standardized Titrant Conc.: 1.0002 mg/mL  
Sample Size: 0.2145 g

Average Sample Conc.: 2146.9 ppm  
Standard Deviation: 13.6675 ppm

Unselect	Escape			Delete
----------	--------	--	--	--------

**Note:** When there are no results selected, dashes will appear in the Average Sample Concentration and the Standard Deviation fields.

## 7. MAINTENANCE AND PERIPHERALS

### 7.1. BURETTE MAINTENANCE

The 5 mL burette included with the titrator exceeds the ISO 8655 standard for the accurate delivery of liquids by a motor-driven piston burette.

#### 7.1.1. BURETTE ASSEMBLY

The burette assembly consists of a rigid housing which holds the glass syringe, a 3-way valve and titrant tubing. The burette assembly is delivered with a 5 mL syringe and with all of the accessories mounted (see [Setup](#) section).

**Note:** The dispensing tube has two fitted ends. One end is equipped with a burette fitting and the other is equipped with a beaker fitting.

##### 7.1.1.1. CHANGING THE BURETTE

Remove the burette from the pump assembly by sliding it forward and then slide the new burette into place (see the picture below).

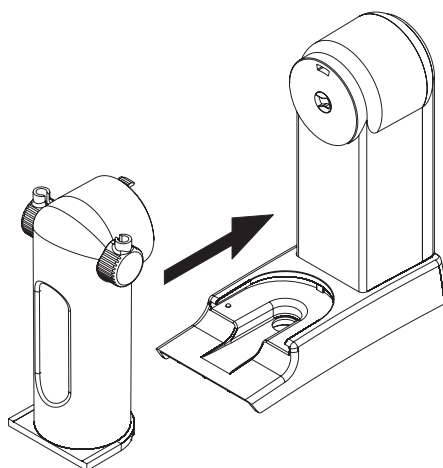

##### 7.1.1.2. DISASSEMBLING THE DISPENSING TUBE AND ASPIRATION TUBE

Both the aspiration and the dispensing tubes have a fitting and a tube protector. The aspiration tube will be mounted on the left side and the dispensing tube will be mounted on the right side of the burette.

To remove the dispensing tube and the aspiration tube follow these steps:

- Remove the blue tube protector (A) by sliding it off the clear titrant tubing
- Remove the tube lock (B) from the burette holder
- Turn the fitting (C) counter-clock wise to remove it from the burette holder
- Slide the clear titrant tubing through the fitting.

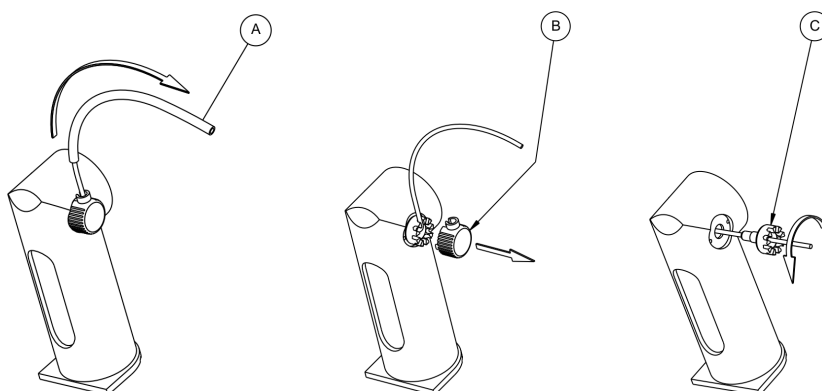

### 7.1.1.3. ASSEMBLING THE DISPENSING TUBE AND ASPIRATION TUBE

To attach the dispensing tube and the aspiration tube follow these steps:

- Insert the flat-shaped end of the titrant tubing into the valve outlet (A) and screw the fitting clock-wise to tighten. The highest of the 9 cuts should be vertical in the final position
- Bend the tube up into the vertical position to enter the highest cut of the fitting (C)
- Replace the tube lock fitting (D)
- Replace the blue tube protector (E) by sliding it over the clear titrant tubing, the protector will sit in the tube lock fitting
- Repeat these steps for the aspiration tube.

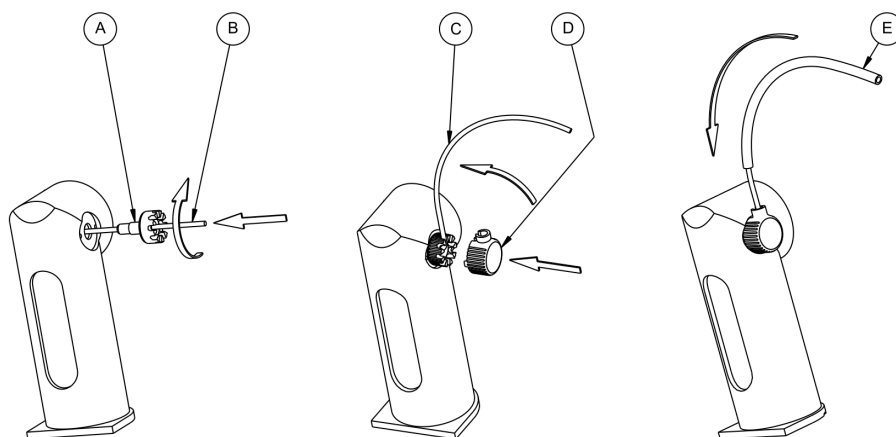

### 7.1.1.4. CLEANING THE BURETTE

To clean the burette, follow these steps:

- If the burette is filled with titrant, remove the aspiration tube from the titrant bottle and purge burette (see [Auxiliary Functions](#) section)
- Insert the aspiration tube into the Karl Fischer solvent
- Prime burette to fill the burette with solvent (use 2 rinses) (see [Auxiliary Functions](#) section)
- During second refilling of the burette remove the aspiration tube from the solvent or cleaning solution and allow the air to replace the liquid in the burette.

If this simple cleaning procedure is not adequate, continue with these steps:

- Slide the burette out from the pump assembly
- Remove the dispensing and aspiration tubes. Clean them separately or use new ones
- Use [HI900942](#) Burette Removal Tool to remove the protective cap from the bottom of the burette assembly
- Use your fingers to unscrew the syringe from the burette assembly
- Extract the piston from the syringe
- Clean both the piston and the syringe with appropriate cleaning solution
- Remove the excess liquid.

**Note:** *Rinse the tubes, syringe and piston with dry solvent (ethanol, isopropanol, or methanol) before reassembling to remove any excess water.*

**Warning!** *Avoid contacting the titrant with bare hands. Avoid spilling titrant. Clean the external side of the syringe and piston to remove aggressive chemicals. Do not touch the white PTFE part of the piston or internal walls of the burette with bare hands or greasy materials.*

Consult Manufacturer's MSDS for safe handling instructions.

- Reinsert the piston into the syringe
- Use your fingers to screw the syringe into the burette assembly
- Reinsert the protective cap to the bottom of the burette assembly. Carefully position the cap into the burette
- Slide the burette into the burette stand. Position the piston shaft to couple the pump correctly
- Priming the burette three times with new titrant is recommended.

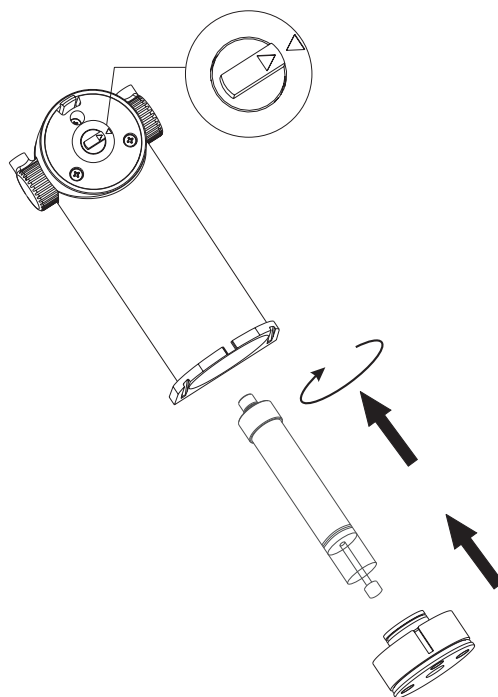

### 7.1.2. BURETTE PREPARATION (TITRANT FILLING)

Before starting a titration, the burette must be properly filled with titrant in order to obtain accurate and repeatable results. To fill the burette, follow the next steps and recommendations:

- If necessary, clean the burette and make sure it is empty
- From the main screen press
- Highlight *Prime Burette* option and press
- Enter the number of times the burette needs to be rinsed (a minimum of three rinses is recommended).
- Press
- Insert the aspiration tube into the titrant bottle only when the piston is going down and has reached about  $\frac{1}{4}$  from the top.
- To avoid the presence of air bubbles inside the burette, ensure to have a continuous liquid flow inside the burette. A little air just above the liquid level at the first filling is normal. The next filling will evacuate all of the air; no air will be left in the valve.
- Sometimes during this process, slight finger tapping on the tubes is helpful to remove any residual air bubbles from the tubes.

## 7.2. PROBE MAINTENANCE

Proper probe maintenance is crucial for reliable measurements and extending the life of the probe. The frequency of maintenance will depend largely on the type of samples that are analyzed. Maintenance may be required if any of the following are observed:

- Slow or no electrode response
- Noisy mV readings
- Debris on or between electrode pins
- Coating on electrode pins

If these signs are observed, the electrode pins may be dirty. Rinse the electrode with a solvent that is appropriate for the type of sample used – methanol is usually sufficient.

Allow the probe to dry completely before reinstalling.

If a more thorough cleaning is required, soak the electrode for several hours in **HI7061** General Purpose pH Electrode Cleaning Solution, then rinse with water followed by methanol. Allow to dry before reinstalling.

After allowing the probe to dry, inspect the glass for any cracks, especially near the electrode pins. Replace the electrode if any cracks are found.

**Warning!** Take care to protect the electrode pins from damage! Avoid using brushes/abrasives to clean the pins. Pins can easily bend, which will cause permanent errors in mV readings!

## 7.3. PERIPHERALS

### 7.3.1. CONNECTING TO A PRINTER

A variety of parallel printers can be connected to the parallel port of the titrator using a DB25 cable.

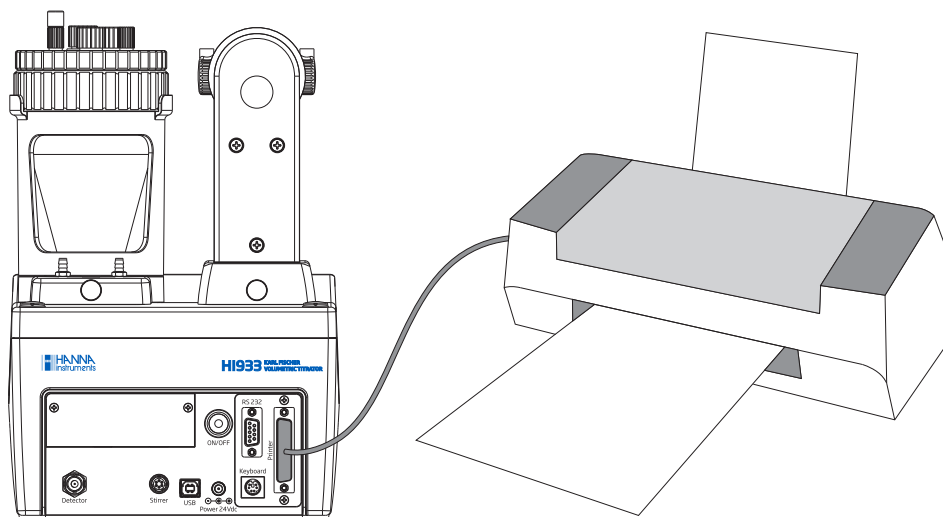

**Warning!** The titrator and the external printer must be both turned OFF before they are connected.

### 7.3.2. CONNECTING TO A COMPUTER

The titrator can be connected to a computer using a USB cable. **HI900** PC application needs to be installed on the PC.

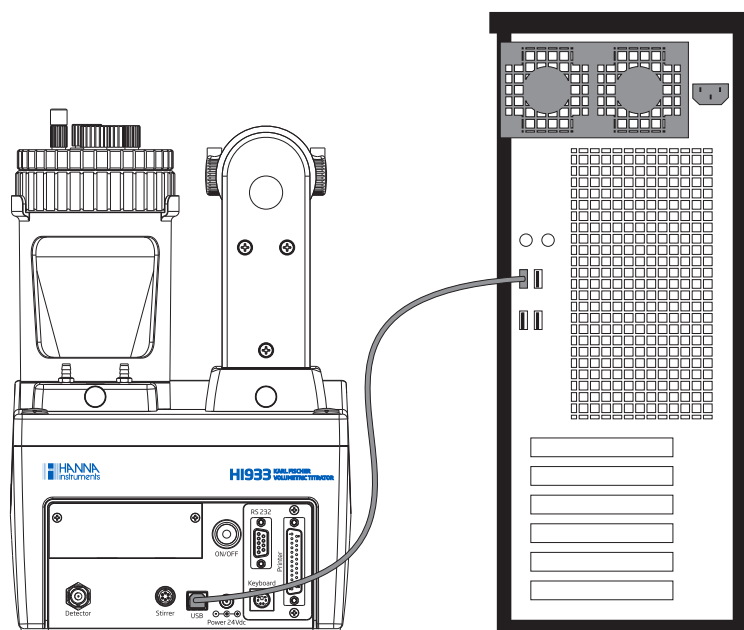

Connect the cable to the USB port on the rear panel of the titrator.

Connect the cable to the USB port on the PC.

Open the **USB Link with PC** screen on the titrator (see **General Options** section).

Launch the **HI900** PC application and then select the appropriate USB Port on the PC.

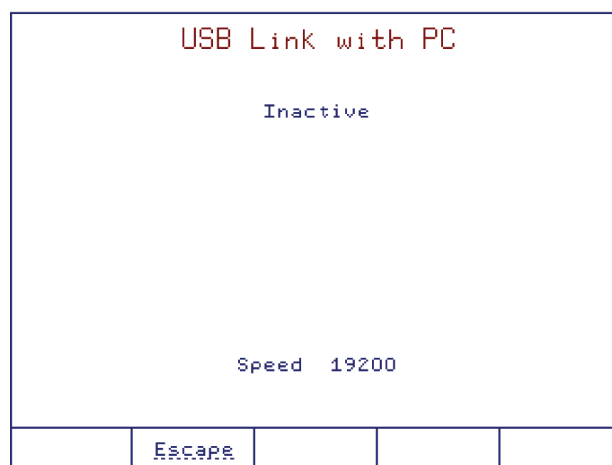

The **HI900** PC application allows the transfer of methods and reports between the titrator and PC.

**Warning!** Connection/disconnection of **POWER CORD**, **PUMP ASSEMBLY**, **PRINTER** or **BALANCE** must only be done when titrator and external devices are turned off.

### 7.3.3. CONNECTING AN EXTERNAL PC KEYBOARD

This connection allows you to use an external PS/2 PC Keyboard in addition to the titrator's keypad.

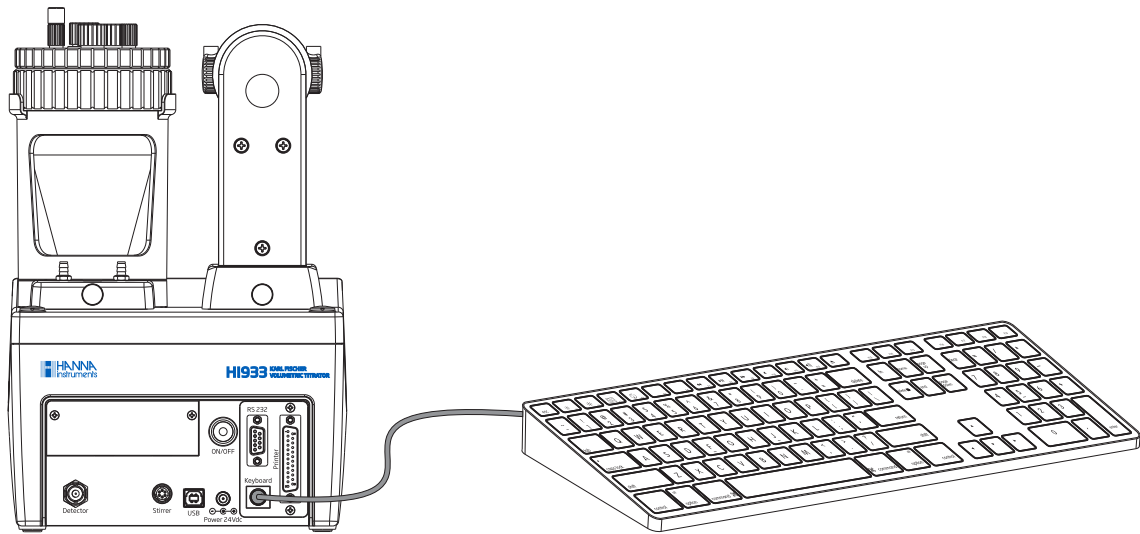

The correspondence between the titrator's keypad and the United States 101-type external keyboard can be found below:

External PC Keyboard (United States 101)	Titrator Keypad
Function Key F-1	
Function Key F-2	
Function Key F-3	
Function Key F-4	
Function Key F-5	Option Key 1 (from left to right)
Function Key F-6	Option Key 2 (from left to right)
Function Key F-7	Option Key 3 (from left to right)
Function Key F-8	Option Key 4 (from left to right)
Function Key F-9	Option Key 5 (from left to right)
Function Key F-10	
Arrow Key: Up	
Arrow Key: Down	
Arrow Key: Left	
Arrow Key: Right	
Page Up	
Page Down	
Numeric Keys: 0 to 9	
Enter	
Alphanumeric Keys	Allow alphanumeric entries

## 8. METHOD OPTIMIZATION

### 8.1. TITRATION SETTINGS

The default settings included with standard methods that have been developed by Hanna Instruments in order to provide accurate results for the majority of samples without requiring additional analyst input or method fine-tuning. However, in order to suit a wider variety of sample types and matrices, all of the **HI933** titration parameters are customizable. This section provides the descriptions of critical titration parameters necessary for an analyst to modify a standard method or develop a titration method from scratch.

**HI933** methods can be modified and customized based on sample requirements, sample matrix and the reagent formulation. The user changeable settings are separated into two categories: Control Parameters, which set critical functions that determine the course of a titration and set the way in which titrations are terminated, and Method Options, which control lesser features not directly affecting measurements and primarily allow advanced users to shorten titration times.

### 8.2. CONTROL PARAMETERS

#### 8.2.1. END POINT POTENTIAL AND POLARIZATION CURRENT

The **HI933** uses a polarized electrode system known as bivoltametric indication. The titrator monitors the voltage required to maintain a constant polarization current ( $I_{pol}$ ) between the dual platinum-pin Karl Fischer electrode during the course of a titration.

During a titration, no excess iodine is present. In order to maintain the set polarization current, the **HI933** must apply a relatively large voltage across the pins of the electrode.

At the end point of a titration, the amount of iodine added is equal to the amount of water from the sample. When an excess of titrant has been added, iodine is present in the solution. The excess iodine is easily reduced, and the resulting iodide is easily oxidized in electrode reactions at the cathode and anode respectively. The ease of these reactions makes maintaining the constant polarization current possible at a much lower electrode potential.

In theory, a large shift in the electrode potential indicates the end point. In practice, a titration end point is reached when the electrode potential drops below a predefined value and the chosen termination criteria is met.

The choice of end point potential should be based, foremost, on the polarization current and, to a lesser extent, on the composition of the Karl Fischer solvent and the sample matrix. If the polarization current is changed, the end point potential must also be changed. In addition, there are pitfalls to be avoided when choosing an end point potential. Selecting end points which are both 'too high' or 'too low' will result in long titration times and poor reproducibility. End points which are 'too high' are those which result in end points that either precede or coincide with equivalence point such that the concentration of excess iodine is not reliably detected. End point potentials are considered 'too low' when they correspond to a large excess of iodine in the titration cell.

Additionally, the duration of a titration is proportional to the polarization current. Thus, titration time can be reduced by increasing the polarization current. While the default ( $I_{pol}$ ) value of 20  $\mu\text{A}$  results in a faster titration than smaller 1, 2, 5, 10, and 15  $\mu\text{A}$  options, a further increase to 30 or 40  $\mu\text{A}$  does not significantly shorten a titration. However, the choice of higher polarization currents will speed contamination of the electrode and potentially degrade samples using special solvent systems.

### 8.2.1.1. DOSING PARAMETERS

The **HI933** predicts the approaching end point and reduces the volumes of titrant added until the end point is reached. This is a software controlled process known as dynamic dosing. Dynamic dosing prevents the addition of titrant beyond the end point and provides enhanced data density in the vicinity of the end point, resulting in accurate end point determination and faster titrations. The minimum and maximum dose volume must be set appropriately by the user for dynamic dosing to be effective.

#### 8.2.1.1.1. MINIMUM DOSE

Decreasing the minimum dose increases precision but lengthens titration time. The only exception is when stability time has been selected as the termination criteria and there is a high drift rate. Under these circumstances, the minimum dose must be large enough to maintain the end point potential by reacting all of the water due to the drift rate over the course of the chosen time period. Increasing the minimum dose shortens titration time but reduces precision and increases the chance of over-titration.

#### 8.2.1.1.2. MAXIMUM DOSE

The maximum dose volume should be adapted according to the formulation and concentration of the titrant. The maximum dose volume should be set as high as possible without exceeding the reaction rate of the reagent system. The table below provides suggested maximum doses for popular reagent systems based on their relative reaction rates. The most effective way to optimize the maximum dose volume is to consider the titration duration and to examine the shape of the titration curve. In the case where the maximum dose volume is too high, the iodine will be added faster than the titration reaction rate. This excess iodine will result in a steep drop in electrode potential which will be interpreted by the **HI933** as an approaching end point. This will, in turn, result in the dynamic dosing algorithm reducing the dose size until the excess iodine has had time to react. The reduced dose size effectively interrupts the titration and adds considerable time to the titration duration. This way the titration will be repeatedly interrupted and the overall titration time takes longer, even though the value of the maximum dose volume is set to large. The graph below shows an example of a titration with a maximum dose that has been set to large.

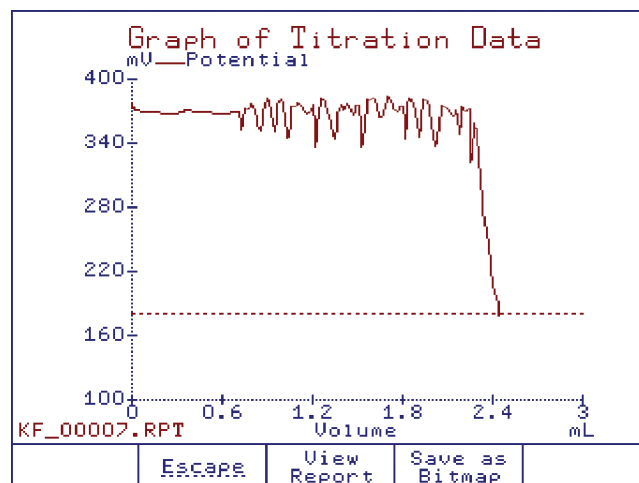

Because reaction rates are faster with two-component reagents than those observed with one-component reagents, the maximum dose volume can be set slightly higher when using two-component systems. When the maximum dose is too low, titration time will be extended.

Karl Fischer Reagent System	Maximum Dose Volume
One-Component Systems	20 to 30 $\mu\text{L}$
One-Component Systems for aldehydes and ketones	20 to 25 $\mu\text{L}$
One-Component Systems formulated with pyridine	15 to 20 $\mu\text{L}$
Two-Component Systems	40 to 60 $\mu\text{L}$
Two-Component Systems formulated with pyridine	25 to 30 $\mu\text{L}$

#### 8.2.1.2. MAXIMUM DOSING MODE

If this option is enabled, when the mV value is greater than 150 mV from the set end point, the algorithm will always dose the maximum value, thus reducing the titration time.

If the titration is noisy, there is a risk of over-titrating the cell.

#### 8.2.1.3. TIMED INCREMENT

This setting controls the amount of time between successive titrant doses.

Setting the time increment appropriately is important to ensure that the titrant has adequate time to mix with the sample such that the electrode measures a homogeneous solution before the titrator makes the decision on the size of the next dose of titrant.

The value of the time increment is dependent on the reagent system being used. While the default value of 1 second is compatible with any reagent system, titrations using two-component reagent systems can be expedited by decreasing the time between successive doses.

#### 8.2.1.4. START MODE

The **HI933** can be set to either normal or cautious start mode. The cautious start feature is designed to prevent the accidental over-titration of a sample with very low water content. In cautious start mode, **HI933** starts a titration using the minimum dose size specified by the user rather than starting with half of the maximum dose size as with normal start mode.

#### 8.2.1.5. SIGNAL AVERAGING

The chosen value for the signal averaging setting determines how many readings the electronics will average to produce a single data point on the titration curve. While higher values of 3, 4, up to 10 readings reduce electrode response time, they also result in a 'smoother' titration curve which may result in a faster titration (single unstable readings may cause the dose volume to be reduced).

#### 8.2.1.6. FLOW RATE

The flow rate setting specifies the volume of titrant delivered per minute. The default flow rate should be used for the majority of titrations. In cases where the titrant is more viscous, the flow rate can be reduced.

### 8.2.2. TERMINATION PARAMETERS

The **HI933** provides a choice of three criteria by which a titration can be considered to have successfully reached an end point.

### 8.2.2.1. STABILITY TIME

When this termination criteria is selected, a titration is considered to have reached an end point when the electrode potential stays below the specified end point potential for a period of time called the stability time. Typical end point stability times range between 5 and 15 seconds.

In order for this criteria to successfully terminate a titration the stability time and the minimum dose size must be set such that, at the end of a titration, the minimum dose size is large enough to react all of the water leaking into the cell due to drift during the set stability time. If the minimum dose volume is too small to compensate for the water introduced by the drift, the titration will never be terminated.

### 8.2.2.2. DRIFT STOP TERMINATION CRITERIA

Drift-based termination criteria, or Drift stop, terminates titrations based on the concept that at the end of a titration, when all of the water due to the sample has been reacted, the titrator should only be titrating the water seeping into the cell due to the background drift rate (see [Drift Analysis](#) section for a detailed explanation of background drift).

Ideally, drift stop termination criteria would end a titration when a drift rate, identical to that which preceded the start of a titration, is observed at the end of a titration. However, from a practical standpoint, the achievement of an identical drift rate results in very long titration times.

In order to shorten titration times while still taking advantage of the positive aspects of drift-based termination, the [HI933](#) incorporates two drift stop termination criteria, relative drift stop and absolute drift stop.

#### 8.2.2.2.1. RELATIVE DRIFT STOP

The relative drift stop termination parameter should be the first choice termination criteria. It is the most universally applicable, easiest to use and results in fast, repeatable titrations.

This parameter has the advantage over other termination criteria in that the relative drift rate termination value can be set independently from the titrant concentration and the initial drift rate.

Under this criteria a titration reaches an end point successfully when the [HI933](#) titrates all of the water introduced with the sample and maintains a drift rate which is equal to the sum of the initial drift (drift rate when the titration was initiated) and the set 'relative drift stop' value (i.e. a slightly higher drift than the initial drift rate).

The choice of relative drift stop value influences the titration duration and reproducibility. Choosing low relative drift stop values (5 to 10  $\mu\text{g}/\text{min}$ ) will result in titrations with high reproducibility and long durations. Setting high relative drift stop values (20 to 30  $\mu\text{g}/\text{min}$ ) will result in fast titrations with potentially reduced reproducibility. Reduced reproducibility at higher drift stop values is of particular concern when using reagents that have slower reaction rates (one-component or aldehyde and ketone reagents).

It is important to set an appropriate relative drift stop value when working with insoluble or sparingly soluble samples. During these types of titrations, the final traces of water are released very slowly. If the sample contains a small amount of water (the final traces are a large fraction of the total water), the relative drift stop value should be set very low. If the final traces can be ignored because the sample water content is large, then the titrations can be terminated at a higher drift rate termination value.

#### 8.2.2.2.2. ABSOLUTE DRIFT STOP

Under this criteria, a titration reaches an end point successfully when the drift falls below a predefined threshold called the absolute drift stop value.

The absolute drift stop value does not take the initial drift rate into account but does have the advantage of being able to be set without consideration of the titrant concentration. In addition, for a titration to reach end point, the absolute drift stop threshold must be set higher than the initial drift rate value.

The primary disadvantage associated with the absolute drift rate termination criteria is that the actual background drift rate must be considered before setting the absolute drift rate threshold. When setting the absolute drift threshold, a balance must be struck between the titration speed and accuracy. Choosing a threshold slightly higher than the initial drift rate will result in high reproducibility and relatively slow titrations. Setting the threshold higher ( $> 30 \mu\text{g}/\text{min}$ ) will result in very fast titrations and reduced titration reproducibility.

### 8.2.3. METHOD OPTIONS

#### 8.2.3.1. PRE-DISPENSING AMOUNT

It is possible to shorten titration times by adding a large fraction of the titrant at the start of the analysis if the approximate water content of the sample is known.

When activated, the pre-dispensing amount can be set to deliver between 1% and 90% of the titrant required to reach the titration end point. A high pre-dispensing amount (around 90%) increases the chances of erroneous results. Pre-dispensing amounts above 50% should only be used if the reaction is very rapid.

#### 8.2.3.2. PRE-ANALYSIS STIR TIME

When analyzing solid samples with limited solubility or samples that release bound water slowly, the sample must be stirred in the chosen solvent prior to the start of a titration, to avoid erroneously low titration results or unreachable end points. The pre-analysis stir time option ensures that after the sample is added the titration mixture is stirred for a period of time before any titrant is added to the cell. The pre-analysis stir time can be set between 0 and 1000 seconds.

#### 8.2.3.3. STIRRING SPEED

The **HI933**'s stirring speed can be set between 200 and 2000 RPM with 100 RPM resolution. The stirring system is equipped with an optical feedback mechanism to ensure that the stirring motor is rotating at the speed set by the user. The optimum stirring speed is obtained when a small vortex is visible. If the stirring speed is too low, the titrant will not react with the sample before reaching the electrode resulting in over-titration and poor titration reproducibility. If the stirring speed is too high, bubbles will form in the solution. Bubbles can destabilize or falsify the measured electrode potential.

The default stirring speed for commercially available standard Karl Fischer reagents, used within the operable volume range of the standard Hanna Instruments cell and with the supplied magnetic stirring bar, is 900 RPM. Samples which result in a titration solution with higher or lower viscosity may require stir speed adjustment.

#### 8.2.3.4. BACKGROUND DRIFT RATE ENTRY

This option provides a choice between the **HI933**'s automatic drift rate determination and assigning a fixed value to be used by the titrator as the drift rate.

The primary benefit of bypassing the automatic drift rate feature is saving time. This is appropriate when titrating samples with high water content where the drift rate is too low to affect titration results or in diagnostic situations where there is no advantage in waiting for the **HI933** to conduct a drift rate analysis.

## 8.3. THE SAMPLE

### 8.3.1. PROPER SAMPLING PROCEDURE

Proper sampling is essential for accurately determining the water content of bulk materials, particularly with non-homogeneous samples. Many standard methods detail instructions to ensure proper sampling. As a general rule, the following guidelines should be followed:

- The sample must be representative. The water content of the sample taken is the same as the average water content of the bulk material.

- Avoid exposing samples to the contaminating effects of atmospheric moisture. Take samples as quickly as possible and protect the sample during transport and/or storage.
- Take samples from the interior of bulk materials. Surfaces of hygroscopic materials may contain higher levels of moisture relative to the rest of the material. Surfaces of materials which release water may contain less water relative to the rest of the material.
- Taking large samples of bulk materials will result in a more representative sample.

### 8.3.2. DETERMINING THE OPTIMAL SAMPLE SIZE

The proper choice of sample size is critical to achieving accurate and repeatable titration results. As a general rule, the sample size should be selected such that about 30-70% of the burette volume is consumed during a titration. This provides enough titrant to ensure good accuracy while conserving reagents and minimizing the generation of waste. The table below illustrates the relationship between titration reproducibility, the volume of titrant consumed during a titration, the amount of water contained in a sample, the size of a sample and the water content of a sample.

Relative Standard Deviation	Titrant Volume Required		Amount of Water in Sample	Size of Sample	Water Content of Sample
	0.002 mL	0.005 mL	10 µg		10%
>5.0%					
3.0%	0.02 mL	0.05 mL	100 µg	0.01 g	1%
1.0%				0.1 g	
0.65%	0.2 mL	0.5 mL	1 mg	1 g	1000 ppm
				10 g	
<0.40%	2.0 mL	5.0 mL	10 mg	100 g	100 ppm
	20 mL	50 mL	100 mg		10 ppm
	5 mg/mL	2 mg/mL			

The ideal sample size can be estimated using the table by drawing a line from the expected water content to the amount of water in the sample corresponding to the desired titration reproducibility (relative standard deviation). The ideal sample size is indicated by where the drawn line intersects the 'size of sample' scale.

Consider the line on the table as an example. The line was drawn for a user with a sample having approximately 1% water who required the best possible reproducibility. The intersection of the red line with the size of sample column indicates that in order to introduce the optimal 10 mg of water into the titration cell, the user must add 1g of sample. The amount of sample required to introduce 10 mg of water into the titration cell can also be calculated directly using the equation below.

$$\text{Sample mass (g)} = \frac{1}{\%H_2O \text{ in sample}}$$

### 8.3.3. SOLID SAMPLES

Sample water must be available to react with the titrant. This typically means that the sample must be adequately dissolved in the solvent. This is achieved by choosing an appropriate solvent system, proper preparation of the sample and optimization of the reaction conditions. After ensuring that the sample is soluble in the choice of solvent or solvent mixture, dissolution of a solid sample can be aided by grinding the sample into a fine powder, increasing the pre-analysis stir time or heating the solvent during a titration with an optional jacketed titration cell and water circulator.

Solid samples are added to the titration cell by removing the sample plug. The quantity of solid sample added can be entered into the **HI933** as a mass or by number of pieces if, for example, pills are to be analyzed. The most accurate way to determine the mass of the sample added to the cell can be achieved by an analytical technique called back-weighing. Back-weighing consists of the following steps:

- Measure the mass of a sample in a weigh boat.
- Initiate the titration sequence on the **HI933** using the 'start analysis' option key from standby mode. This will bring up the "add sample" screen.
- Slide the sample plug up, out of the vessel top to open the sample port.
- Rapidly add the sample through the sample port ensuring that ALL of the sample is transferred to the solvent. Avoid any contact between the sample and the cell walls or top.
- Replace the sample plug into the vessel top.
- Determine the mass of the "empty" weigh boat.
- Calculate the mass of the sample added (subtract the mass of the emptied weigh boat from the mass of the full weigh boat).
- Enter the calculated mass of the sample into the **HI933**.
- Start titration using the option key 'start analysis' from the add sample screen.

Care should be taken to add a solid sample as fast as possible in order to minimize the amount of time that the sample port is open. It is also important to be sure that all of the sample reaches the solvent and does not make contact with, or stick to, the inner sides of the vessel cap. Losing even a small fraction of the sample mass will result in a high sample water content.

In some cases solid samples may require one of the additional preparatory steps listed in the sections that follow. Specific sample preparation instructions are included with each standard method.

#### 8.3.4. LIQUID SAMPLES

As with solids, the water contained in liquid samples must be available to react with the titrant. It is important to select a solvent system or mixture with which the sample is miscible.

Liquids are typically added through the septum in the sample port via a syringe and needle using the following steps:

- Attach a long needle (approximately 6 cm long, 21-gauge) to a syringe large enough to hold at least one complete sample volume.
- Rinse the syringe and needle with sample several times by drawing in a small portion of sample, fully extending the plunger, shaking to coat the syringe interior and expelling the sample into a waste collection container.
- Draw enough sample into the syringe for at least one titration.
- Dry the outside of the needle with a lint free wipe or tissue.
- Determine the mass of the syringe and sample.
- Initiate a titration from standby mode by pressing the "start analysis" option key.
- Insert the needle through the septum in the sample port. Push the syringe through the septum until the end of the needle is approximately 1 cm from the surface of the solvent.
- Steadily dispense the contents of the syringe ensuring that the sample is introduced directly into the solvent and does not splash or spatter onto the wall of the titration vessel electrode or dispensing tip.
- Draw a small amount of air from inside the cell into the syringe to ensure that no sample drops remain on the tip of the needle.
- Remove the syringe and needle from the septum taking care to not touch the needle to the solvent or other internal cell components.

- Determine the mass of the syringe and needle.
- Calculate the mass of the sample added to the titration cell (subtract the mass of the syringe after the sample has been added from the mass of the syringe before sample addition).
- Enter the calculated mass of the sample into the **HI933**.
- Start titration using the option key  from the add sample screen.

As indicated above, when adding a liquid sample with a needle and syringe, it is important that the sample is introduced directly into the solvent. Sample that is deposited on the sides of the vessel or other internal components of the cell may not be titrated with the rest of the sample. It is equally important that no drops remain on the tip of the needle. "Hanging drops" will end up on the bottom of the septum. This will result in false low results for the determination.

Liquid samples with high viscosity, like honey, can be added via a syringe without needle through the sample port following the steps outlined above.

In some cases, liquid samples may require one of the additional preparatory steps listed in the sections that follow. Specific sample preparation instructions are included with each standard method.

### 8.3.5. SAMPLE PREPARATION TECHNIQUES

While many samples can be introduced directly into the titration vessel (see **Sample Addition** section), others require preparatory steps. It is critical that samples are not contaminated with additional water or lose water during the preparation phase.

The steps required for the most common sample preparation techniques are outlined below. For detailed application-specific instructions, consult the instructions included with applicable standard methods.

The **HI933** provides options for the automatic calculation of samples prepared normally, using external extraction and external dissolution.

#### 8.3.5.1. INTERNAL EXTRACTIONS

Internal extractions are carried out using the "normal" sample type option within the "sample parameters menu". This type of sample preparation is suitable for solid samples which release their water relatively quickly (during the pre-analysis stir time) and exhibit limited or no solubility in Karl Fischer solvents. Internal extraction should be used preferentially over external extraction techniques because the extracted water is titrated immediately, which favors complete extraction by Le Chatlier's principle.

An outline of the general procedure follows:

- Add methanol or an appropriate solvent to the titration cell and pre-titrate to dryness.
- Adjust the pre-analysis stir time to be sufficiently long to complete the extraction. Appropriate set times will be sample and solvent specific. Consult an applicable standard method or experiment by increasing the pre-analysis stir time and titrating samples until the resulting water content no longer increases.
- Reduce the samples to as fine of a powder as possible to ensure that sample water is extracted quickly.
- Add the sample to the titration vessel using the back weighing method.

#### 8.3.5.2. DILUTIONS

It is very difficult to accurately add very small amounts of sample to the titration vessel. In order to produce accurate and reproducible results, samples having water content greater than 50% should therefore be diluted with a dry solvent before being introduced into the titration vessel. Dilutions are carried out using the 'external dissolution' sample type option.

Anhydrous methanol is the solvent of choice for sample dilutions. If the sample contains fats or oils, then a mixture of methanol and chloroform can be used to promote solubility of the sample.

The following outlines a generic dilution procedure:

- Determine the mass of a dry flask equipped with a septum stopper.
- Transfer approximately 1 g of sample to the flask and measure the mass of the flask and the sample together.
- Add 30 grams of dilution solvent to the flask. Re-seal and mix the flask contents.
- Determine the moisture content of the dry solvent used as the diluent in a separate titration.
- Add the diluted sample as per the instructions for adding liquid samples in this section.

#### 8.3.5.3. EXTERNAL DISSOLUTION

External dissolutions are recommended for titrations which require a large amount of soluble solid sample due to inhomogeneous water distribution or very low water content. External dissolution reduces the error typically associated with the titration of low water content solids by collecting the water released by a large amount of solid sample by dissolving it in a relatively small amount of solvent. A small portion of the solvent can then be injected into the titration vessel.

Sample preparation and choice of solvent or solvent mixture is sample specific. Consult an applicable standard method for procedural details.

The **HI933** will conduct the necessary calculations automatically when “external dissolution” is selected from the sample type menu.

#### 8.3.5.4. EXTERNAL EXTRACTION

External extraction is recommended for insoluble solid samples which release water slowly.

The **HI933** will conduct the necessary calculations automatically when “external extraction” is selected from the sample type menu.

An outline of a general procedure follows:

- Determine the mass of an extraction bottle or flask equipped with a septum.
- Add the extraction solvent to the bottle and determine the mass of the bottle and the solvent. In order to maximize the effectiveness of the extraction, the water content of the solvent should be as low as possible. When choosing an extraction solvent, one must carefully consider the limit of water saturation for a possible solvent.
- Determine the water content of the solvent.
- Determine the mass of the solvent remaining in the extraction bottle.
- Add a finely crushed sample to the solvent in the extraction bottle. The amount of sample added should be large enough so that the amount of water in the sample is much greater than that in the solvent before the extraction.
- Facilitate extraction by shaking the solution or placing the solution on a stirring plate or in a sonicator.
- Allow the insoluble portion of the sample to settle to the bottom of the extraction bottle.
- Titrate an appropriately sized sample of the supernatant (solvent above the settled solid sample).

#### 8.3.5.5. HOMOGENIZATION

Homogenization is recommended for non-aqueous or mixed phase liquid samples as well as solids with inhomogeneous distributions of water. Water can be evenly distributed throughout a collected sample by the use of high speed, high shear mixers called homogenizers.

In mixed phase (oil and water) non-aqueous samples, water tends to migrate to the surface of the sample solution, adhere to the inner walls of or sink to the bottom of the sample bottle. This is particularly problematic when sampling is done at high temperatures and the specimen is subsequently allowed to cool to room temperature prior to analysis. Solid samples typically exhibit inhomogeneous water distributions and must therefore be thoroughly reduced to powder or homogenized. The procedure for homogenization depends upon the characteristics of the specific sample.

Homogenization is particularly suited for semi-solid samples and suspensions and is the only method that can disrupt plant and tissue cells in order to release water present inside the cells. Homogenization is typically carried out externally in a dry flask with the addition of a suitable solvent, preferably methanol.

#### 8.3.5.6. HEATING

Sample heating is used for the analysis of solid or liquid samples that cannot be extracted or that interfere with the Karl Fischer reaction. These include plastics, minerals, petrochemical products which contain additives, and starting materials for pharmaceutical products.

Samples are heated in a special oven while a dry stream of carrier gas passes through the sample chamber or, for liquid samples, the sample itself. The carrier gas is introduced into the titration vessel.

The heating temperature is sample specific and can be found in applicable standard methods. The temperatures are chosen to be as high as possible without decomposing the sample, which can result in contamination of the titration vessel.

### 8.4. KARL FISCHER REAGENT SYSTEM

A wide variety of Karl Fischer reagents exist on the market today, each designed and formulated for specific sample matrices and titration conditions. Karl Fischer reagent systems consist of a solvent and a titrant. The solvent is the liquid to which the sample is added in the reaction vessel. The titrant is the iodine-containing liquid pumped into the cell during the titration.

#### 8.4.1. REAGENT SYSTEM CLASSIFICATION

Reagent systems are classified as either one-component or two-component depending on whether the sulfur dioxide and base are included in the titrant or with the solvent. In one-component systems, also known as composites, the titrant contains all of the reactants needed to conduct the titration (iodine, sulfur dioxide and a base) dissolved in an alcohol or ether. In a two-component reagent system, the solvent already contains the sulfur dioxide and the base while the titrant is typically a solution consisting of iodine and methanol.

##### 8.4.1.1. ONE-COMPONENT REAGENT SYSTEMS

One-component reagents are less stable than two-component systems, typically having only a two-year shelf life, but they provide several significant advantages. The major advantage is that the titrant is providing the sulfur dioxide and the base. The constant supply of reaction components from the titrant allows a high level of flexibility with respect to the chemical composition of the solvent and provides a nearly limitless solvent capacity for water. One-component solvent systems can be easily customized, creating mixtures specially adapted to specific sample characteristics without having to worry about providing appropriate levels of sulfur dioxide and buffer components. Common solvent mixtures include ethanol, chloroform, xylene, toluene, and long chain alcohols such as hexanol and decanol.

##### 8.4.1.2. TWO-COMPONENT REAGENT SYSTEMS

Two-component reagents have advantages of their own. They are more stable and have a longer shelf life than one-component systems. The sulfur dioxide is pre-mixed in excess with an alcohol-based solvent, therefore the necessary reactive sulfite esters are present in vast excess prior to the start of a titration. This results in higher titration speeds and greater accuracy for low levels of water. In addition, having the base present in excess in the solvent prior to sample addition results in a higher solvent buffer capacity.

##### 8.4.1.3. REAGENTS FOR ALDEHYDES AND KETONES

The addition of a sample containing aldehydes or ketones to a methanol-based Karl Fischer solvent results in side reactions that adversely affect titration results. When alcohols react with the carbonyl groups of aldehydes and ketones

they form acetals and ketals via a reaction that releases water. The generation of water during a titration will falsely inflate water content results and could lead to vanishing end points.

While ketones are less reactive than aldehydes, the reactivity of both species is inversely proportional to carbonyl chain lengths. The formation of acetals and ketals is also dependent on the type of alcohol included in the solvent. As the chain length of an alcohol's alkyl or substituted alkyl group increases, the alcohol's reactivity toward ketones and aldehydes decreases (i.e. methanol is the most reactive). Acetal or ketal formation can be prevented by the use of methanol-free reagents specially produced for this purpose. Reagents for aldehyde and ketone analysis replace methanol with higher alcohols, ethers, halogenated alkanes or similar combinations.

#### 8.4.2. CHOOSING AND MODIFYING A SOLVENT

The solvent plays an important role in the KF titration. It must react with sulfur dioxide to form the reactive methyl sulfite species, dissolve the sample and/or extract water, and it should help prevent side reactions from occurring. The most common solvent is methanol. Co-solvents can be added to increase sample solubility in one-component solvents, as long as the mixture contains at least 20 - 30% methanol. In a two-component reagent system, 50% solvent for two-component system and 50% co-solvent can be used. This ensures that there is enough sulfur dioxide and base for the Karl Fischer reaction to take place.

In general, a solvent should be chosen in accordance with the sample composition.

Fats, oils and long-chain hydrocarbons have limited solubility in methanol. Co-solvents of long-chain alcohols (n-decanol) or chloroform should be used.

Carbohydrates and proteins have poor solubility in methanol, formamide can be used as a co-solvent. Analyzing acids or bases may take the pH outside the optimal range and additional buffering may be required. A commercial Karl Fischer 'Buffer' reagent can be added or extra imidazole for acid samples and salicylic acid to the solvent for basic samples. For analysis of ketones or aldehydes, the methanol can be replaced with special "K" reagents that contain mixtures including 2-chloroethanol, chloroform, ethanol or 1-methoxy-2-propanol.

#### 8.4.3. WATER STANDARDS

Water standards are used to standardize the titrant and to verify the titrator's performance and analyst technique. Water standards are an integral part of ISO 9000, GMP, GLP and FDA guidelines for water determination.

The most commonly utilized water standard for volumetric Karl Fischer titration is sodium tartrate dihydrate. Available as a highly-purified, non-hygroscopic powder, sodium tartrate dihydrate has a stable water content of  $15.66 \pm 0.05\%$ . The compound is, however, sparingly soluble in methanol requiring at least 3 minutes of stirring for complete dissolution. If high precision or NIST traceability is required, water standards sealed in glass ampules are also commercially available. Although they are more expensive, sealed standards come pre-analyzed and certified by the manufacturer and are available in a wide range of concentrations.

The experienced analyst can also use very small volumes of deionized water as a standard. Due to the very water-sensitive nature of a Karl Fischer titration, only a few milligrams of water are required for a typical standardization or system verification. A great deal of skill is therefore required in determining the mass of the water introduced into the titration vessel in order to achieve highly accurate results.

#### 8.4.4. STANDARDIZING THE TITRANT

Standardizing the Titrant, or determining the titer, is a routine and necessary part of accurate Karl Fischer analyses. The titrant should be standardized daily for greatest accuracy. Standardization serves to standardize the combination of parameters selected as part of a particular method and serves as a system check. It is recommended that the titrant be

re-standardized if the method to be used for an analysis is very different from that which was used to standardize the titrant initially. The titrant can be standardized using hydrated salt, liquid water standards or tiny amounts of pure water. A general procedure for titrant standardization is detailed below.

- Setup titrator according to the instruction manual. Ensure the titrator is set up with the same reagents, solvents, working conditions, temperature and titrator settings to be used for subsequent sample analyses.
- Select the appropriate standardization method included with the [HI933](#).

If using a Sodium Tartrate Dihydrate Standard:

- Back-weigh between 30 and 200 mg of standard. Be sure that the salt is a high quality standard, which has been stored properly and exists as a fine, free flowing powder.
- Repeat the standardization at least three times and update the titrant concentration using the averaged result value via the statistics screen if the variability between the standardizations is small.

If using a Prepared Liquid Water Standard (Ampule):

- Break open an ampule of standard. Rinse a syringe with a small portion of standard.
- Draw up the remainder of the standard into the syringe, weight and titrate about one third of the standard in the syringe.
- Conduct two more standardizations with the standard remaining in the syringe.
- Review the set of results on the “average results” statistics screen. The titrant concentration should be updated with the averaged results as long as there is not excessive variability between standardization results.

If using pure water standards:

- Draw approximately 10  $\mu\text{L}$  of pure water into a glass micro-liter syringe.
- Introduce the water standard by back-weighing using an analytical balance with 0.01 mg resolution. Because of the extremely small sample size, it is important to strictly follow the procedure for the addition of liquid samples outlined in the section “Liquid samples” above.
- Review the set of results on the “average results” statistics screen. The titrant concentration should be updated with the averaged results as long as there is not excessive variability between standardization results.

## 9. ACCESSORIES

### 9.1. TITRANTS

#### 9.1.4.3.1. ONE-COMPONENT TITRANTS

- Honeywell® HYDRANAL™ - Composite 1 (Catalog Number 34827)  
 HYDRANAL™ - Composite 2 (Catalog Number 34806)  
 HYDRANAL™ - Composite 5 (Catalog Number 34805)  
 HYDRANAL™ - Composite 5 K (Catalog Number 34816)
- GFS Chemicals® Watermark® - Single Solution, 2 mg/mL (Catalog Number 1601)  
 Watermark® - Non-Hazardous Single Solution, 2 mg/mL (Catalog Number 1894)  
 Watermark® - Single Solution, 5 mg/mL (Catalog Number 1600)  
 Watermark® - Non-Hazardous Single Solution, 5 mg/mL (Catalog Number 1893)  
 Watermark® - Methanol Based, 5 mg/mL (Catalog Number 1616)
- J.T. Baker® Hydra-Point™ - Composite 2 (Catalog Number 8891)  
 Hydra-Point™ - Composite 5 (Catalog Number 8890)  
 Hydra-Point™ - Composite 5K (Catalog Number 8892)

#### 9.1.4.3.2. TWO-COMPONENT TITRANTS

- Honeywell® HYDRANAL™ - Titrant 2 (Catalog Number 34811)  
 HYDRANAL™ - Titrant 2 E (Catalog Number 34723)  
 HYDRANAL™ - Titrant 5 (Catalog Number 34801)  
 HYDRANAL™ - Titrant 5 E (Catalog Number 34732)
- GFS Chemicals® Watermark® - Non-hygroscopic Titrant, 0.5 mg/mL (Catalog Number 1970)  
 Watermark® - Non-hygroscopic Titrant, 1 mg/mL (Catalog Number 1602)  
 Watermark® - Non-hygroscopic Titrant, 2 mg/mL (Catalog Number 1603)  
 Watermark® - Non-hygroscopic Titrant, 5 mg/mL (Catalog Number 1604)
- J.T. Baker® Hydra-Point™ - Composite 2 (Catalog Number 8845)  
 Hydra-Point™ - Composite 5 (Catalog Number 8844)

### 9.2. SOLVENTS

#### 9.2.4.3.1. ONE-COMPONENT SOLVENTS

- Honeywell® HYDRANAL™ - Methanol Dry (Catalog Number 34741)  
 HYDRANAL™ - Methanol Rapid (Catalog Number 37817)  
 HYDRANAL™ - CompoSolver E (Catalog Number 34734)  
 HYDRANAL™ - Solver (Crude) Oil (Catalog Number 34697)  
 HYDRANAL™ - LipoSolver CM (Catalog Number 37855)  
 HYDRANAL™ - LipoSolver MH (Catalog Number 37856)  
 HYDRANAL™ - Medium K (Catalog Number 34698)  
 HYDRANAL™ - KetoSolver (Catalog Number 34738)  
 HYDRANAL™ - Working Medium K (Catalog Number 34817)  
 HYDRANAL™ - Karl Fischer Reagent (Catalog Number 36115)

- GFS Chemicals® Watermark® - General Purpose Solvent (Catalog Number 1610)  
 Watermark® - Methanol Solvent (Catalog Number 1609)  
 Watermark® - Ketone/Aldehyde Solvent (Catalog Number 5322)  
 Watermark® - Oils Solvent (Catalog Number 2978)  
 Watermark® - Methyl Alcohol - KF Grade (Catalog Number 3569)
- J T Baker® Hydra-Point™ - Methanol Dry (Catalog Number 8898)w

#### 9.2.4.3.2. TWO-COMPONENT SOLVENTS

- Honeywell HYDRANAL™ - Solvent (Catalog Number 34800)  
 HYDRANAL™ - Solvent E (Catalog Number 34730)  
 HYDRANAL™ - Solvent CM (Catalog Number 34812)  
 HYDRANAL™ - Solvent Oil (Catalog Number 34749)
- GFS Chemicals® Watermark® - General Purpose Solvent (Catalog Number 1610)  
 Watermark® - Methanol Free Solvent (Catalog Number 1609)  
 Watermark® - Buffer (Catalog Number 1615)  
 Watermark® - KF Solvent for Oil (Catalog Number 2991)
- J.T. Baker® Hydra-Point™ - Solvent G (Catalog Number 8855)

#### 9.3. STANDARDS

- Honeywell® HYDRANAL™ - Standard Sodium Tartrate Dihydrate (Catalog Number 34696)  
 HYDRANAL™ - Water Standard 10.0 (Catalog Number 34849)  
 HYDRANAL™ - Water Standard 1.0 (Catalog Number 34828)  
 HYDRANAL™ - Water Standard 0.1 (Catalog Number 34847)
- GFS Chemicals® Watermark® - Sodium Tartrate (Catalog Number 805)  
 Watermark® - 10 mg/g (Catalog Number 2303)  
 Watermark® - 5.00 mg/g (Catalog Number 2304)  
 Watermark® - 1.00 mg/g (Catalog Number 2302)  
 Watermark® - 0.50 mg/g (Catalog Number 3493)  
 Watermark® - 0.100 mg/g (Catalog Number 2301)  
 Watermark® - 0.050 mg/g (Catalog Number 2311)

## 9.4. TITRATOR COMPONENTS

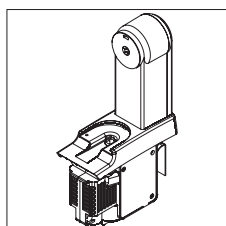

Pump Assembly  
HI930100

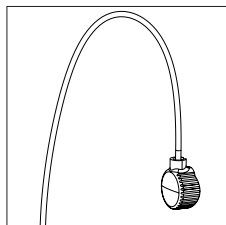

Aspiration Tubing  
HI900570S

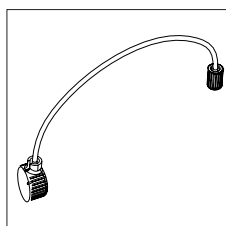

Dispensing Tubing  
and Fitting  
HI900580S

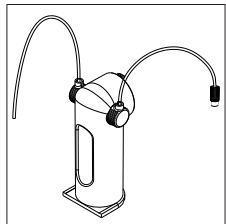

5 mL Burette Assembly  
HI930505

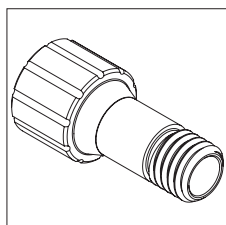

Tool for Burette Cap  
Removal  
HI900942

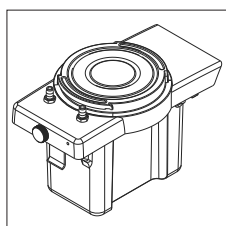

Air Pump and magnetic  
stirrer for HI933/HI934  
HI930180

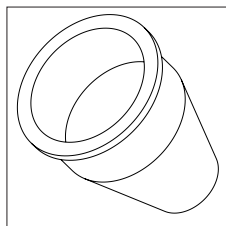

Beaker for HI903/HI933  
HI900522

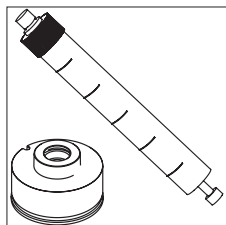

5 mL Syringe  
HI900205

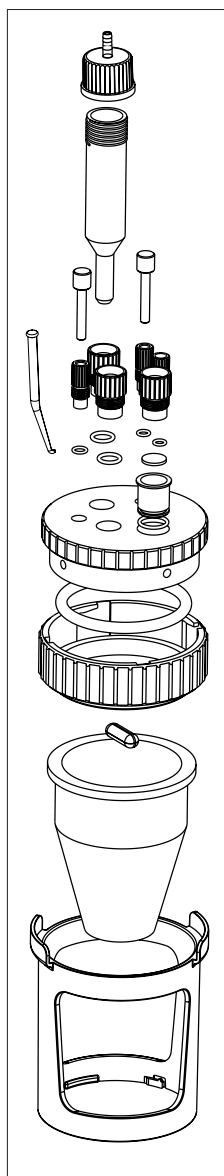

Beaker Assembly  
HI930520

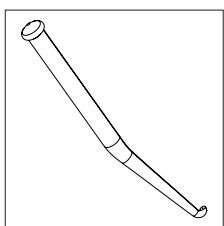

Dispensing Tip (2 pcs.)  
HI900523

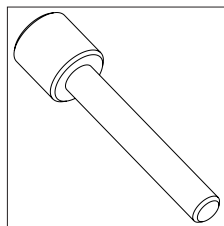

Solvent Port Plugs (2 pcs.)  
HI900528

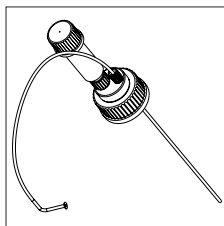

Titration Bottle Top Assembly  
HI900530

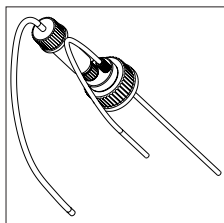

Solvent/Waste Bottle Top  
Assembly  
HI900531

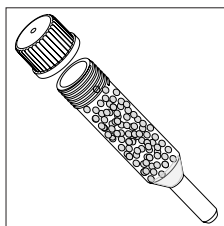

Desiccant Cartridge for  
Titration Beaker or Titrant  
Bottle  
HI900532

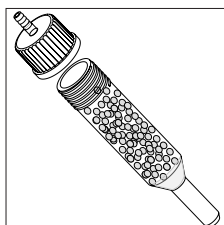

Desiccant Cartridge for  
Solvent or Waste Bottle  
HI900533

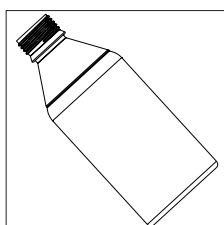

Waste Bottle  
HI900534

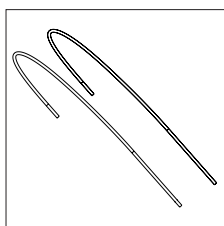

Tubing for Solvent/Waste  
Handling (2 pcs.)  
HI900535

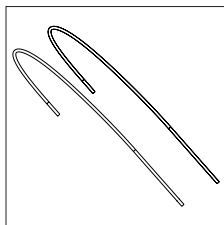

Tubing for Air Pump (2 pcs.)  
HI900536

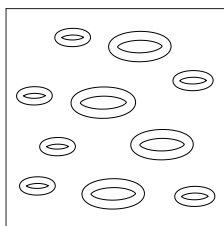

O-Ring Set  
HI900540

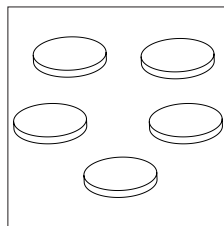

Septum (5 pcs.)  
HI900527

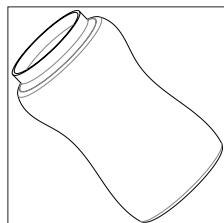

Desiccant, 250 g  
HI900550

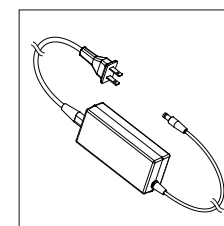

Power Adapter (USA Plug)  
HI900946

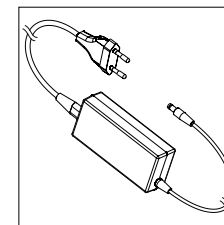

Power Adapter (European Plug)  
HI900947

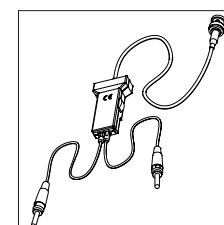

Calibration Key  
HI900941

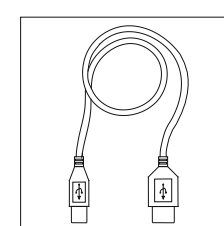

USB Cable  
HI920013

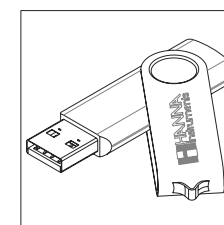

USB Flash Drive  
HI930900U

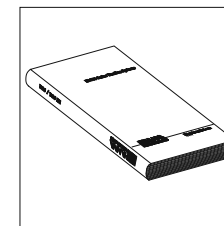

Instruction Manual Binder  
HI930803

## PART 3:

## APPLICATIONS



## HI8001EN 5.0 mg/mL TITRANT STANDARDIZATION WITH WATER STANDARD

### One-Component Titrant

#### DESCRIPTION

Method for the standardization (titer determination) of 5.0 mg/mL one-component Karl Fischer titrant using a Liquid Water Standard. The results are expressed in **mg/mL**.

#### ELECTRODE

- HI76320 Dual Platinum Pin Electrode

#### REAGENTS

- 5 mg/mL one-component Karl Fischer volumetric titrant
- 10 mg/g Liquid water standard
- Dry methanol

#### ACCESSORIES

- 3 mL syringe (clean and dry)
- 22-gauge, 6" non-coring septum penetration needle (clean and dry)
- Solvent bottle, GL45 thread

#### DEVICE PREPARATION

- Connect the solvent bottle top assembly to the bottle of methanol according to the manual.
- Assemble the titration vessel according to the instruction manual.
- Install a 5 mL burette filled with 5 mg/mL one-component Karl Fischer volumetric titrant to be standardized and verify that no air bubbles are present in the burette or tubing. If necessary, prime until all air has been removed completely.
- Press **Select Method** from the main screen. Use the arrow keys to highlight *HI8001EN 5mg/mL Stdz w/water std* and press **Select**.
- Dispense enough methanol from the solvent bottle to fill the vessel to the "min" line (about 50 mL).
- Press **start stop** to pre-titrate the solvent and the titration vessel moisture. Allow the background drift rate to stabilize before proceeding to the next step.

#### ANALYSIS

- Fill the syringe and needle with the water standard.
- Weigh the syringe, needle and water standard.
- Press **Start Analysis**. You will be prompted to enter the sample size.
- Dispense 1.00 g (about 1 mL) of standard into the titration vessel through the septum using the needle.
- Pay attention not to get any sample on the electrode or beaker wall. If necessary, swirl the titration vessel gently by hand to remove any standard from the electrode or beaker wall.
- Clear the needle of residual standard by intaking a small volume of air from the titration vessel. If a "hanging drop" of standard is seen on the end of the needle, dip the end of the needle briefly in the solvent.
- Remove the needle from the titration vessel and weigh the syringe again in order to determine the exact amount of standard added (by difference of the two measurements.)
- Use the numeric keypad to enter the exact weight and press **enter** to start the analysis.
- At the end of the titration, the **Standardization Result** screen is displayed. The results are expressed in **mg/mL**.

**METHOD PARAMETERS**

Name: 5mg/mL Stdz w/water std  
 Method Revision: 1.1  
 Type: Titrant Standardization  
 Predispensing Amount: 25 %  
 Pre-Analysis Stir Time: 5 Sec  
 Stirring Speed: 900 RPM  
 Stirbar Type: Medium  
 Drift Entry: Automatic  
 Solvent: Methanol  
 Standard: Liquid 10 mg/g  
 Type: Liquid by mass  
 Concentration Unit: mg/g  
 Water Content: 10.0000 mg/g  
 Standard Size: 1.0000 g  
 Titrant: Composite 5  
 Titrant Type: one-component  
 Nominal Titrant Conc.: 5.0000 mg/mL  
 Std. Titrant Conc.: 5.0000 mg/mL  
 Date/Time: Apr 02, 2019 11:45  
 Titrant Age Reminder: 2d:00h:00m  
**Control Parameters:**  
 Start Mode: Normal  
 Standby Mode: Enabled  
 Standby Duration: 12:00 [hh:mm]  
 Imposed Current: 20 µA  
 Minimum Dose: 0.500 µL  
 Maximum Dose: 20.000 µL  
 Max Dosing Mode: Disabled  
 Timed Increment: 1 second  
 End Point Value: 180.0 mV  
 Signal Averaging: 3 Readings  
 Flow Rate: 10.0 mL/min  
**Termination Parameters:**  
 Maximum Duration: 1200 sec  
 Maximum Titrant Volume: 10.000 mL  
 Term. Criterion: Relative Drift  
 Relative Drift: 7.0 µg/min  
 Significant Figures: XXXXX

**CALCULATIONS**

Titrant units: mg/mL  
 Titrant volume consumed: V (mL)  
 Final Results Units: mg/mL  
 Standard Concentration: 10.0000 mg/g  
 Standard mass: 1.0000 g [w/w]

$$\text{mg/mL} = \frac{10.0000 \times 1.0000}{V}$$

**RESULTS**

**Titration Report**  
 Method Name: 5mg/mL Stdz w/water std  
 Time & Date: Apr 03, 2019 12:00  
 Standard Size: 1.0000 g  
 Standard Conc.: 10.0000 mg/g  
 Drift Value: 5.4 µg/min  
 End Point Volume: 2.0341 mL  
 Result: 4.9276 mg/mL  
 Titration Duration: 4:19 [mm:ss]  
 Estimated Cell Volume: 55.88 mL  
 Titration went to Completion  
 Operator Name:  
 Analyst Signature: \_\_\_\_\_

## HI8002EN 2.0 mg/mL TITRANT STANDARDIZATION WITH WATER STANDARD

### One-Component Titrant

#### DESCRIPTION

Method for the standardization (titer determination) of 2.0 mg/mL one-component Karl Fischer titrant using a Liquid Water Standard. The results are expressed in **mg/mL**.

#### ELECTRODE

- HI76320 Dual Platinum Pin Electrode



#### REAGENTS

- 2 mg/mL one-component Karl Fischer volumetric titrant
- 1 mg/g Liquid water standard
- Dry methanol



#### ACCESSORIES

- 3 mL syringe (clean and dry)
- 22-gauge, 6" non-coring septum penetration needle (clean and dry)
- Solvent bottle, GL45 thread

#### DEVICE PREPARATION

- Connect the solvent bottle top assembly to the bottle of methanol according to the manual.
- Assemble the titration vessel according to the instruction manual.
- Install a 5 mL burette filled with 2 mg/mL one-component Karl Fischer volumetric titrant to be standardized and verify that no air bubbles are present in the burette or tubing. If necessary, prime until all air has been removed completely.
- Press  from the main screen. Use the arrow keys to highlight *HI8002EN 2mg/mL Stdz w/water std* and press .
- Dispense enough methanol from the solvent bottle to fill the vessel to the "min" line (about 50 mL).
- Press  to pre-titrate the solvent and the titration vessel moisture. Allow the background drift rate to stabilize before proceeding to the next step.

#### ANALYSIS

- Fill the syringe and needle with the water standard.
- Weigh the syringe, needle and water standard.
- Press . You will be prompted to enter the sample size.
- Dispense 2.00 g (about 2 mL) of standard into the titration vessel through the septum using the needle.
- Pay attention not to get any sample on the electrode or beaker wall. If necessary, swirl the titration vessel gently by hand to remove any standard on the electrode or beaker wall.
- Clear the needle of residual standard by intaking a small volume of air from the titration vessel. If a "hanging drop" of standard is seen on the end of the needle, dip the end of the needle briefly in the solvent.
- Remove the needle from the titration vessel and weigh the syringe again in order to determine the exact amount of standard added (by difference of the two measurements.)
- Use the numeric keypad to enter the exact weight and press  to start the analysis.
- At the end of the titration, the **Standardization Result** screen is displayed. The results are expressed in **mg/mL**.

**METHOD PARAMETERS**

Name: 2mg/mL Stdz w/water std  
 Method Revision: 1.1  
 Type: Titrant Standardization  
 Predispensing Amount: 25 %  
 Pre-Analysis Stir Time: 5 Sec  
 Stirring Speed: 900 RPM  
 Stirbar Type: Medium  
 Drift Entry: Automatic  
 Solvent: Methanol  
 Standard: Liquid 1.0 mg/g  
   Type: Liquid by mass  
   Concentration Unit: mg/g  
   Water Content: 1.0000 mg/g  
 Standard Size: 2.0000 g  
 Titrant: Composite 2  
   Titrant Type: one-component  
   Nominal Titrant Conc.: 2.0000 mg/mL  
   Std. Titrant Conc.: 2.0000 mg/mL  
   Date/Time: Apr 02, 2019 11:45  
   Titrant Age Reminder: 2d:00h:00m  
**Control Parameters:**  
   Start Mode: Normal  
   Standby Mode: Enabled  
   Standby Duration: 12:00 [hh:mm]  
   Imposed Current: 20 µA  
   Minimum Dose: 1.000 µL  
   Maximum Dose: 20.000 µL  
   Max Dosing Mode: Disabled  
   Timed Increment: 1 second  
   End Point Value: 180.0 mV  
   Signal Averaging: 3 Readings  
   Flow Rate: 10.0 mL/min  
**Termination Parameters:**  
   Maximum Duration: 1200 sec  
   Maximum Titrant Volume: 10.000 mL  
   Term. Criterion: Relative Drift  
   Relative Drift: 7.0 µg/min  
 Significant Figures: XXXXX

**CALCULATIONS**

Titrant units: mg/mL  
 Titrant volume consumed: V (mL)  
 Final Results Units: mg/mL  
 Standard Concentration: 1.0000 mg/g  
 Standard mass: 2.0000 g

$$\text{mg/mL} = \frac{1.0000 \times 2.0000}{V}$$

**RESULTS**

Method Name: 2mg/mL Stdz w/water std  
 Time & Date: Apr 03, 2019 12:00  
 Standard Size: 2.0000 g  
 Standard Conc.: 1.0000 mg/g  
 Drift Value: 5.0 µg/min  
 End Point Volume: 1.0496 mL  
 Result: 1.9103 mg/mL  
 Titration Duration: 5:10 [mm:ss]  
 Estimated Cell Volume: 60.11 mL  
 Titration went to Completion  
 Operator Name:  
 Analyst Signature: \_\_\_\_\_

## HI8003EN 1.0 mg/mL TITRANT STANDARDIZATION WITH WATER STANDARD

### One-Component Titrant

#### DESCRIPTION

Method for the standardization (titer determination) of 1.0 mg/mL one-component Karl Fischer titrant using a Liquid Water Standard. The results are expressed in **mg/mL**.

#### ELECTRODE

- HI76320 Dual Platinum Pin Electrode



#### REAGENTS

- 1 mg/mL one-component Karl Fischer volumetric titrant
- 1 mg/g Liquid Water Standard
- Dry methanol



#### ACCESSORIES

- 3 mL syringe (clean and dry)
- 22-gauge, 6" non-coring septum penetration needle (clean and dry)
- Solvent bottle, GL45 thread

#### DEVICE PREPARATION

- Connect the solvent bottle top assembly to the bottle of methanol according to the manual.
- Assemble the titration vessel according to the instruction manual.
- Install a 5 mL burette filled with 1 mg/mL Karl Fischer volumetric titrant to be standardized and verify that no air bubbles are present in the burette or tubing. If necessary, prime until all air has been removed completely.
- Press  from the main screen. Use the arrow keys to highlight *HI8003EN 1mg/mL Stdz w/water std* and press .
- Dispense enough methanol from the solvent bottle to fill the vessel to the "min" line (about 50 mL).
- Press  to pre-titrate the solvent and the titration vessel moisture. Allow the background drift rate to stabilize before proceeding to the next step.

#### ANALYSIS

- Fill the syringe and needle with the water standard.
- Weigh the syringe, needle and water standard.
- Press . You will be prompted to enter the sample size.
- Dispense 2.00 g (about 2 mL) of standard into the titration vessel through the septum using the needle.
- Pay attention not to get any sample on the electrode or beaker wall. If necessary, swirl the titration vessel gently by hand to remove any standard on the electrode or beaker wall.
- Clear the needle of residual standard by intaking a small volume of air from the titration vessel. If a "hanging drop" of standard is seen on the end of the needle, dip the end of the needle briefly in the solvent.
- Remove the needle from the titration vessel and weigh the syringe again in order to determine the exact amount of standard added (by difference of the two measurements.)
- Use the numeric keypad to enter the exact weight and press  to start the analysis.
- At the end of the titration, the **Standardization Result** screen is displayed. The results are expressed in **mg/mL**.

**METHOD PARAMETERS**

Name: 1mg/mL Stdz w/water std  
 Method Revision: 1.1  
 Type: Titrant Standardization  
 Predispensing Amount: 25 %  
 Pre-Analysis Stir Time: 5 Sec  
 Stirring Speed: 900 RPM  
 Stirbar Type: Medium  
 Drift Entry: Automatic  
 Solvent: Methanol  
 Standard: Liquid 1.0 mg/g  
   Type: Liquid by mass  
   Concentration Unit: mg/g  
   Water Content: 1.0000 mg/g  
 Standard Size: 2.0000 g  
 Titrant: Composite 1  
   Titrant Type: one-component  
   Nominal Titrant Conc.: 1.0000 mg/mL  
   Std. Titrant Conc.: 1.0000 mg/mL  
   Date/Time: Apr 02, 2019 11:45  
 Titrant Age Reminder: 2d:00h:00m  
 Control Parameters:  
   Start Mode: Normal  
   Standby Mode: Enabled  
   Standby Duration: 12:00 [hh:mm]  
   Imposed Current: 20 µA  
   Minimum Dose: 2.000 µL  
   Maximum Dose: 40.000 µL  
   Max Dosing Mode: Disabled  
   Timed Increment: 1 second  
   End Point Value: 180.0 mV  
   Signal Averaging: 3 Readings  
   Flow Rate: 10.0 mL/min  
 Termination Parameters:  
   Maximum Duration: 1200 sec  
   Maximum Titrant Volume: 10.000 mL  
   Term. Criterion: Relative Drift  
   Relative Drift: 7.0 µg/min  
 Significant Figures: XXXXX

**CALCULATIONS**

Titrant units: mg/mL  
 Titrant volume consumed: V (mL)  
 Final Results Units: mg/mL  
 Standard Concentration: 1.0000 mg/g  
 Standard mass: 2.0000 g

$$\text{mg/mL} = \frac{1.0000 \times 2.0000}{V}$$

**RESULTS**

Method Name: 1mg/mL Stdz w/water std  
 Time & Date: Apr 03, 2019 12:00  
 Standard Size: 2.0000 g  
 Standard Conc.: 1.0000 mg/g  
 Drift Value: 5.0 µg/min  
 End Point Volume: 1.8528 mL  
 Result: 1.0824 mg/mL  
 Titration Duration: 5:30 [mm:ss]  
 Estimated Cell Volume: 64.20 mL  
 Titration went to Completion  
 Operator Name:  
 Analyst Signature: \_\_\_\_\_

## HI8011EN 5.0 mg/mL TITRANT STANDARDIZATION WITH DISODIUM TARTRATE

### One-Component Titrant

#### DESCRIPTION

Method for the standardization (titer determination) of 5.0 mg/mL one-component Karl Fischer titrant using Disodium Tartrate Dihydrate water standard. The results are expressed in **mg/mL**.

#### ELECTRODE

- HI76320 Dual Platinum Pin Electrode

#### REAGENTS

- 5 mg/mL one-component Karl Fischer volumetric titrant
- Disodium Tartrate Dihydrate, 15.66% H<sub>2</sub>O (w/w)
- Dry methanol
- Dry formamide

#### ACCESSORIES

- Weigh boat (clean and dry)
- Solvent bottle, GL45 thread

#### SOLVENT PREPARATION

- Prepare at least 200 mL of solvent. Add dry methanol and dry formamide 2:1 to the solvent bottle.

#### DEVICE PREPARATION

- Connect the solvent bottle top assembly to the bottle of solvent according to the manual.
- Assemble the titration vessel according to the instruction manual.
- Install a 5 mL burette filled with 5 mg/mL one-component Karl Fischer Titrant to be standardized and verify that no air bubbles are present in the burette or tubing. If necessary, prime until all air has been removed completely.
- Press **Select Method** from the main screen. Use the arrow keys to highlight *HI8011EN 5mg/mL Stdz w/ tartrate* and press **Select**.
- Dispense enough solvent from the solvent bottle to fill the vessel to the "min" line (about 50 mL).
- Press **start stop** to pre-titrate the solvent and the titration vessel moisture. Allow the background drift rate to stabilize before proceeding to the next step.

#### ANALYSIS

- Add 0.050 g to 0.100 g of tartrate standard to a weigh boat.
- Weigh the weigh boat and tartrate standard.
- Press **Start Analysis**. You will be prompted to enter the sample size.
- Quickly remove the sample port plug from the beaker assembly, pour the tartrate into the titration vessel, and replace the sample port plug.
- Pay attention not to get any sample on the electrode or beaker wall. If necessary, swirl the titration vessel gently by hand to remove any standard on the electrode or beaker wall.
- Weigh the weigh boat again in order to determine the exact amount of standard added (by difference of the two measurements.)
- Use the numeric keypad to enter the exact weight and press **enter** to start the analysis.
- At the end of the titration the **Standardization Result** screen is displayed. The results are expressed in **mg/mL**.

## METHOD PARAMETERS

Name: 5mg/mL Stdz w/tartrate  
 Method Revision: 1.1  
 Type: Titrant Standardization  
 Predisensing Amount: 15 %  
 Pre-Analysis Stir Time: 30 Sec  
 Stirring Speed: 900 RPM  
 Stirbar Type: Medium  
 Drift Entry: Automatic  
 Solvent: MeOH Form. 2:1  
 Standard: Sodium Tartrate  
 Type: Solid by mass  
 Concentration Unit: %  
 Water Content: 15.66 %  
 Standard Size: 0.1000 g  
 Titrant: Composite 5  
 Titrant Type: one-component  
 Nominal Titrant Conc.: 5.0000 mg/mL  
 Std. Titrant Conc.: 5.0000 mg/mL  
 Date/Time: Apr 02, 2019 11:45  
 Titrant Age Reminder: 2d:00h:00m  
 Control Parameters:  
 Start Mode: Normal  
 Standby Mode: Enabled  
 Standby Duration: 12:00 [hh:mm]  
 Imposed Current: 20 µA  
 Minimum Dose: 2.000 µL  
 Maximum Dose: 40.000 µL  
 Max Dosing Mode: Disabled  
 Timed Increment: 1 second  
 End Point Value: 180.0 mV  
 Signal Averaging: 3 Readings  
 Flow Rate: 10.0 mL/min  
 Termination Parameters:  
 Maximum Duration: 1200 sec  
 Maximum Titrant Volume: 10.000 mL  
 Term. Criterion: Relative Drift  
 Relative Drift: 7.0 µg/min  
 Significant Figures: XXXXX

## CALCULATIONS

Titrant units: mg/mL  
 Titrant volume consumed: V (mL)  
 Final Results Units: mg/mL  
 Standard Concentration: 15.66 %  
 Standard mass: 0.1000 g[W/W]

$$\text{mg/mL} = \frac{0.1000 \times 0.1566 \times 1000}{V}$$

## RESULTS

Method Name: 5mg/mL Stdz w/tartrate  
 Time & Date: Apr 03, 2019 12:00  
 Standard Size: 0.1000 g  
 Standard Conc.: 15.66 %  
 Drift Value: 4.0 µg/min  
 End Point Volume: 3.1333 mL  
 Result: 5.0329 mg/mL  
 Titration Duration: 8:48 [mm:ss]  
 Estimated Cell Volume: 69.26 mL  
 Titration went to Completion  
 Operator Name:  
 Analyst Signature: \_\_\_\_\_

## HI8101EN MOISTURE DETERMINATION IN DAIRY CREAM

### DESCRIPTION

Method for the determination of moisture in dairy cream. The results are expressed in **% mass** and should be between 70 and 80 %.

### ELECTRODE

- HI76320 Dual Platinum Pin Electrode

### REAGENTS

- 5 mg/mL one-component Karl Fischer volumetric titrant
- Dry methanol
- Dry chloroform
- Dry formamide



### ACCESSORIES

- 1 mL syringe (clean and dry)
- 22-gauge, 6" non-coring septum penetration needle (clean and dry)
- Solvent bottle, GL45 thread

### SOLVENT PREPARATION



- Prepare at least 200 mL of solvent. Add 2 parts dry chloroform, 2 parts dry methanol and 1 part dry formamide to the solvent bottle.

### DEVICE PREPARATION

- Connect the solvent bottle top assembly to the bottle of solvent according to the manual.
- Assemble the titration vessel according to the instruction manual.
- Install a 5 mL burette filled with 5 mg/mL one-component Karl Fischer volumetric titrant and verify that no air bubbles are present in the burette or tubing. If necessary, prime until all air has been removed completely.
- Press  from the main screen. Use the arrow keys to highlight *HI8101EN Moisture in Dairy Cream* and press .

- For the determination of the exact concentration of the titrant, follow HI8001EN 5mg/mL Stdz w/water std or HI8011EN 5mg/mL Stdz w/tartrate.
- Dispense enough solvent from the solvent bottle to fill the vessel to the "min" line (about 50 mL).
- Press  to pre-titrate the solvent and the titration vessel moisture. Allow the background drift rate to stabilize before proceeding to the next step.

### ANALYSIS

- Fill the syringe and needle with the sample.
- Weigh the syringe, needle and dairy cream.
- Press . You will be prompted to enter the sample size.
- Dispense 0.020 g to 0.025 g of dairy cream into the titration vessel through the septum using the needle.
- Pay attention not to get any sample on the electrode or beaker wall. If necessary, swirl the titration vessel gently by hand to remove any sample on the electrode or beaker wall.
- Clear the needle of residual sample by intaking a small volume of air from the titration vessel. If a "hanging drop" of sample is seen on the end of the needle, dip the end of the needle briefly in the solvent.
- Remove the needle from the titration vessel and weigh the syringe again in order to determine the added sample mass (by difference of the two measurements.)
- Use the numeric keypad to enter the exact weight and press  to start the analysis.
- At the end of the titration the **Result** screen is displayed. The results are expressed in **% mass**.

**METHOD PARAMETERS**

Name: Moisture in Dairy Cream  
 Method Revision: 1.1  
 Type: Sample Analysis  
 Predispensing Amount: 30 %  
 Pre-Analysis Stir Time: 30 Sec  
 Stirring Speed: 900 RPM  
 Stirbar Type: Medium  
 Drift Entry: Automatic  
 Solvent: Cream Solvent  
 Sample Parameters:  
   Sample Determ.: Normal  
   Sample Name: Dairy Cream  
   Sample Type: Mass  
   Sample Size: 0.0250 g  
 Titrant: Composite 5  
   Titrant Type: one-component  
   Nominal Titrant Conc.: 5.0000 mg/mL  
   Std. Titrant Conc.: 5.0000 mg/mL  
   Date/Time: Apr 02, 2019 11:45  
   Titrant Age Reminder: 2d:00h:00m  
 Control Parameters:  
   Start Mode: Normal  
   Standby Mode: Enabled  
   Standby Duration: 12:00 [hh:mm]  
   Imposed Current: 20 µA  
   Minimum Dose: 0.500 µL  
   Maximum Dose: 30.000 µL  
   Max Dosing Mode: Disabled  
   Timed Increment: 1 second  
   End Point Value: 180.0 mV  
   Signal Averaging: 3 Readings  
   Flow Rate: 10.0 mL/min  
 Termination Parameters:  
   Maximum Duration: 900 sec  
   Maximum Titrant Volume: 10.000 mL  
   Term. Criterion: Relative Drift  
   Relative Drift: 15.0 µg/min  
 Result Unit: %  
 Significant Figures: XXXXX

**CALCULATIONS**

Titrant units: mg/mL  
 Titrant volume consumed: V (mL)  
 Final results units: % Mass  
 Titrant concentration: 5.0000 mg/mL  
 Sample mass: 0.0250 g

$$\% \text{ Mass} = \frac{V \times 5.0000}{0.025 \times 10}$$

**RESULTS**

Method Name: Moisture in Dairy Cream  
 Time & Date: Apr 03, 2019 12:00  
 Sample Size: 0.0241 g  
 Std. Titrant Conc.: 5.0000 mg/mL  
 Drift Value: 4.7 µg/min  
 End Point Volume: 3.4567 mL  
 Result: 71.5481 %  
 Titration Duration: 8:36 [mm:ss]  
 Estimated Cell Volume: 65.72 mL  
 Titration went to Completion  
 Operator Name:  
 Analyst Signature: \_\_\_\_\_

## HI8102EN MOISTURE DETERMINATION IN MILK

## DESCRIPTION

Method for the determination of moisture in milk. The results are expressed in **% mass** and should be between 80 and 95 %.

## ELECTRODE

- HI76320 Dual Platinum Pin Electrode



## REAGENTS

- 5 mg/mL one-component Karl Fischer volumetric titrant
- Dry methanol



## ACCESSORIES

- 1 mL syringe (clean and dry)
- 22-gauge, 6" non-coring septum penetration needle (clean and dry)
- Solvent bottle, GL45 thread

## DEVICE PREPARATION

- Connect the solvent bottle top assembly to the bottle of methanol according to the manual.
- Assemble the titration vessel according to the instruction manual.
- Install a 5 mL burette filled with 5 mg/mL one-component Karl Fischer volumetric titrant and verify that no air bubbles are present in the burette or tubing. If necessary, prime until all air has been removed completely.
- Press  from the main screen. Use the arrow keys to highlight *HI8102EN Moisture in Milk* and press .
- For the determination of the exact concentration of the titrant, follow *HI8001EN 5mg/mL Stdz w/ water std* or *HI8011EN 5mg/mL Stdz w/tartrate*.
- Dispense enough methanol from the solvent bottle to fill the vessel to the "min" line (about 50 mL).
- Press  to pre-titrate the solvent and the titration vessel moisture. Allow the background drift rate to stabilize before proceeding to the next step.

## ANALYSIS

- Fill the syringe and needle with the sample.
- Weigh the syringe, needle and milk.
- Press . You will be prompted to enter the sample size.
- Dispense 0.015 g to 0.020 g of milk into the titration vessel through the septum using the needle.
- Pay attention not to get any sample on the electrode or beaker wall. If necessary, swirl the titration vessel gently by hand to remove any sample on the electrode or beaker wall.
- Clear the needle of residual sample by intaking a small volume of air from the titration vessel. If a "hanging drop" of sample is seen on the end of the needle, dip the end of the needle briefly in the solvent.
- Remove the needle from the titration vessel and weigh the syringe again in order to determine the added sample mass (by difference of the two measurements.)
- Use the numeric keypad to enter the exact weight and press  to start the analysis.
- At the end of the titration the **Result** screen is displayed. The results are expressed in **% mass** of water.

## METHOD PARAMETERS

Name: Moisture in Milk  
 Method Revision: 1.1  
 Type: Sample Analysis  
 Predispensing Amount: 30 %  
 Pre-Analysis Stir Time: 15 Sec  
 Stirring Speed: 900 RPM  
 Stirbar Type: Medium  
 Drift Entry: Automatic  
 Solvent: Methanol

Sample Parameters:  
 Sample Determ.: Normal  
 Sample Name: Milk  
 Sample Type: Mass  
 Sample Size: 0.0200 g

Titration:  
 Titration Type: Composite 5  
 Titration Type: one-component  
 Nominal Titration Conc.: 5.0000 mg/mL  
 Std. Titration Conc.: 5.0000 mg/mL  
 Date/Time: Apr 02, 2019 11:45  
 Titration Age Reminder: 2d:00h:00m

Control Parameters:  
 Start Mode: Normal  
 Standby Mode: Enabled  
 Standby Duration: 12:00 [hh:mm]  
 Imposed Current: 20  $\mu$ A  
 Minimum Dose: 0.500  $\mu$ L  
 Maximum Dose: 40.000  $\mu$ L  
 Max Dosing Mode: Disabled  
 Timed Increment: 1 second  
 End Point Value: 180.0 mV  
 Signal Averaging: 3 Readings  
 Flow Rate: 10.0 mL/min

Termination Parameters:  
 Maximum Duration: 900 sec  
 Maximum Titration Volume: 10.000 mL  
 Term. Criterion: Relative Drift  
 Relative Drift: 15.0  $\mu$ g/min  
 Result Unit: %  
 Significant Figures: XXXXX

## CALCULATIONS

Titration units: mg/mL  
 Titration volume consumed: V (mL)  
 Final results units: % Mass  
 Titration concentration: 5.0000 mg/mL  
 Sample mass: 0.0200 g

$$\% \text{ Mass} = \frac{V \times 5.0000}{0.0200 \times 10}$$

## RESULTS

Method Name: Moisture in Milk  
 Time & Date: Apr 03, 2019 12:00  
 Sample Size: 0.0188 g  
 Std. Titration Conc.: 5.0000 mg/mL  
 Drift Value: 4.5  $\mu$ g/min  
 End Point Volume: 3.2614 mL  
 Result: 86.5886 %  
 Titration Duration: 6:18 [mm:ss]  
 Estimated Cell Volume: 60.03 mL  
 Titration went to Completion  
 Operator Name:  
 Analyst Signature: \_\_\_\_\_

## HI8103EN MOISTURE DETERMINATION IN HONEY

## DESCRIPTION

Method for the determination of moisture in honey. The results are expressed in **% mass** and should be between 15 and 20 %.

## ELECTRODE

- HI76320 Dual Platinum Pin Electrode



## REAGENTS

- 5 mg/mL one-component Karl Fischer volumetric titrant
- Dry methanol



## ACCESSORIES

- 1 mL syringe (clean and dry)
- Solvent bottle, GL45 thread

## DEVICE PREPARATION

- Connect the solvent bottle top assembly to the bottle of methanol according to the manual.
- Assemble the titration vessel according to the instruction manual.
- Install a 5 mL burette filled with 5 mg/mL one-component Karl Fischer volumetric titrant and verify that no air bubbles are present in the burette or tubing. If necessary, prime until all air has been removed completely.
- Press  from the main screen. Use the arrow keys to highlight *HI8103EN Moisture in Honey* and press .
- For the determination of the exact concentration of the titrant, follow *HI8001EN 5mg/mL Stdz w/ water std* or *HI8011EN 5mg/mL Stdz w/tartrate*.
- Dispense enough methanol from the solvent bottle to fill the vessel to the “min” line (about 50 mL).
- Press  to pre-titrate the solvent and the titration vessel moisture. Allow the background drift rate to stabilize before proceeding to the next step.

## ANALYSIS

- Fill the syringe with the sample.
- Weigh the syringe, needle and honey.
- Press . You will be prompted to enter the sample size.
- Remove the sample port plug and dispense 0.050 g to 0.100 g of honey (about 2-3 small drops) into the titration vessel through the sample port. Replace the sample port plug as quickly as possible to prevent humidity from entering the titration beaker.
- Pay attention not to get any sample on the electrode or beaker wall. If necessary, swirl the titration vessel gently by hand to remove any sample on the electrode or beaker wall.
- Weigh the syringe again in order to determine the added sample mass (by difference of the two measurements.)
- Use the numeric keypad to enter the exact weight and press  to start the analysis.
- At the end of the titration the **Result** screen is displayed. The results are expressed in **% mass** of water.

**METHOD PARAMETERS**

Name: Moisture in Honey  
 Method Revision: 1.1  
 Type: Sample Analysis  
 Predisensing Amount: None  
 Pre-Analysis Stir Time: 60 Sec  
 Stirring Speed: 900 RPM  
 Stirbar Type: Medium  
 Drift Entry: Automatic  
 Solvent: Methanol  
 Sample Parameters:  
   Sample Determ.: Normal  
   Sample Name: Honey  
   Sample Type: Mass  
   Sample Size: 0.1000 g  
 Titrant: Composite 5  
   Titrant Type: one-component  
   Nominal Titrant Conc.: 5.0000 mg/mL  
   Std. Titrant Conc.: 5.0000 mg/mL  
   Date/Time: Apr 02, 2019 11:45  
   Titrant Age Reminder: 2d:00h:00m  
 Control Parameters:  
   Start Mode: Normal  
   Standby Mode: Enabled  
   Standby Duration: 12:00 [hh:mm]  
   Imposed Current: 20 µA  
   Minimum Dose: 0.500 µL  
   Maximum Dose: 20.000 µL  
   Max Dosing Mode: Disabled  
   Timed Increment: 1 second  
   End Point Value: 180.0 mV  
   Signal Averaging: 3 Readings  
   Flow Rate: 10.0 mL/min  
 Termination Parameters:  
   Maximum Duration: 900 sec  
   Maximum Titrant Volume: 10.000 mL  
   Term. Criterion: Relative Drift  
   Relative Drift: 10.0 µg/min  
 Result Unit: %  
 Significant Figures: XXXXX

**CALCULATIONS**

Titrant units: mg/mL  
 Titrant volume consumed: V (mL)  
 Final results units: % Mass  
 Titrant concentration: 5.0000 mg/mL  
 Sample mass: 0.1000 g

$$\% \text{ Mass} = \frac{V \times 5.0000}{0.1000 \times 10}$$

**RESULTS**

Method Name: Moisture in Honey  
 Time & Date: Apr 03, 2019 12:00  
 Sample Size: 0.0916 g  
 Std. Titrant Conc.: 5.0000 mg/mL  
 Drift Value: 3.8 µg/min  
 End Point Volume: 3.4523 mL  
 Result: 17.2345 %  
 Titration Duration: 7:06 [mm:ss]  
 Estimated Cell Volume: 57.16 mL  
 Titration went to Completion  
 Operator Name:  
 Analyst Signature: \_\_\_\_\_

## HI8104EN SURFACE MOISTURE DETERMINATION ON WHITE SUGAR

### DESCRIPTION

Method for the determination of the surface moisture content of white sugar. The results are expressed in ppm and should be between 250 and 350 ppm.

### ELECTRODE

- HI76320 Dual Platinum Pin Electrode

### REAGENTS

- 1 mg/mL one-component Karl Fischer volumetric titrant
- Dry methanol
- Dry chloroform



### ACCESSORIES

- Weigh boat (clean and dry)
- Solvent bottle, GL45 thread



### SOLVENT PREPARATION

- Prepare at least 200 mL of solvent. Add 2 parts dry chloroform and 1 part dry methanol to the solvent bottle.

### DEVICE PREPARATION

- Connect the solvent bottle top assembly to the bottle of solvent according to the manual.
- Assemble the titration vessel according to the instruction manual.
- Install a 5 mL burette filled with 1 mg/mL one-component Karl Fischer volumetric titrant and verify that no air bubbles are present in the burette or tubing. If necessary, prime until all air has been removed completely.
- Press  from the main screen. Use the arrow keys to highlight *HI8104EN Surface Moisture - Sugar* and press .
- For the determination of the exact concentration of the titrant follow *HI8003EN 1mg/mL Stdz w/water std.*
- Dispense enough solvent from the solvent bottle to fill the vessel to the "min" line (about 50 mL).
- Press  to pre-titrate the solvent and the titration vessel moisture. Allow the background drift rate to stabilize before proceeding to the next step.

### ANALYSIS

- Fill the weigh boat with 7.5 to 10.0 g of sample.
- Weigh the weigh boat and sample.
- Press . You will be prompted to enter the sample size.
- Remove the sample port and use the weigh boat to transfer the solid sample into the titration vessel. Replace the sample port plug as quickly as possible to prevent humidity from entering the titration beaker.
- Pay attention not to get any sample on the electrode or beaker wall. If necessary, swirl the titration vessel gently by hand to remove any sample on the electrode or beaker wall.
- Weigh the weigh boat again in order to determine the added sample mass (by difference of the two measurements.)
- Use the numeric keypad to enter the exact weight and press  to start the analysis.
- At the end of the titration the **Result** screen is displayed. The results are expressed in ppm of water.
- Replace the solvent after 2 to 3 titrations.

**METHOD PARAMETERS**

Name: Surface Moisture - Sugar  
 Method Revision: 1.1  
 Type: Sample Analysis  
 Predisensing Amount: None  
 Pre-Analysis Stir Time: 120 Sec  
 Stirring Speed: 900 RPM  
 Stirbar Type: Medium  
 Drift Entry: Automatic  
 Solvent: CHCl<sub>3</sub> MeOH 2:1  
 Sample Parameters:  
 Sample Determ.: Normal  
 Sample Name: Sugar  
 Sample Type: Mass  
 Sample Size: 7.5000 g  
 Titrant: Composite 1  
 Titrant Type: one-component  
 Nominal Titrant Conc.: 1.0000 mg/mL  
 Std. Titrant Conc.: 1.0000 mg/mL  
 Date/Time: Apr 02, 2019 11:45  
 Titrant Age Reminder: 2d:00h:00m  
 Control Parameters:  
 Start Mode: Normal  
 Standby Mode: Enabled  
 Standby Duration: 12:00 [hh:mm]  
 Imposed Current: 20 µA  
 Minimum Dose: 1.000 µL  
 Maximum Dose: 30.000 µL  
 Max Dosing Mode: Disabled  
 Timed Increment: 1 second  
 End Point Value: 180.0 mV  
 Signal Averaging: 3 Readings  
 Flow Rate: 10.0 mL/min  
 Termination Parameters:  
 Maximum Duration: 900 sec  
 Maximum Titrant Volume: 10.000 mL  
 Term. Criterion: Relative Drift  
 Relative Drift: 20.0 µg/min  
 Result Unit: ppm  
 Significant Figures: XXXXX

**CALCULATIONS**

Calculations:  
 Titrant units: mg/mL  
 Titrant volume consumed: V (mL)  
 Final results units: ppm  
 Titrant concentration: 1.0000 mg/mL  
 Sample mass: 7.5000 g

$$\text{ppm} = \frac{V \times 1.0000 \times 1000}{7.500}$$

**RESULTS**

Method Name: Surface Moisture-Sugar  
 Time & Date: Apr 03, 2019 12:00  
 Sample Size: 7.5231 g  
 Std. Titrant Conc.: 1.0000 mg/mL  
 Drift Value: 5.7 µg/min  
 End Point Volume: 2.4292 mL  
 Result: 319 ppm  
 Titration Duration: 4:42 [mm:ss]  
 Estimated Cell Volume: 62.4 mL  
 Titration went to Completion  
 Operator Name:  
 Analyst Signature: \_\_\_\_\_

## HI8105EN MOISTURE DETERMINATION IN COOKING OIL

### DESCRIPTION

Method for the determination of moisture in cooking oil. The results are expressed in ppm and should be between 200 and 800 ppm.

### ELECTRODE

- HI76320 Dual Platinum Pin Electrode

### REAGENTS

- 1 mg/mL one-component Karl Fischer volumetric titrant
- Dry methanol
- Dry chloroform



### ACCESSORIES

- 25 mL syringe (clean and dry)
- 18-gauge, 6" non-coring septum penetration needle (clean and dry)
- Solvent bottle, GL45 thread

### SOLVENT PREPARATION



- Prepare at least 200 mL of solvent. Add equal parts of dry chloroform and dry methanol to the solvent bottle.

### DEVICE PREPARATION

- Connect the solvent bottle top assembly to the bottle of solvent according to the manual.
- Assemble the titration vessel according to the instruction manual.
- Install a 5 mL burette filled with 1 mg/mL one-component Karl Fischer volumetric titrant and verify that no air bubbles are present in the burette or tubing. If necessary, prime until all air has been removed completely.
- Press  from the main screen. Use the arrow keys to highlight *HI8105EN Moisture in Cooking Oil* and press .
- For the determination of the exact concentration of the titrant follow *HI8003EN 1mg/mL Stdz w/water std.*
- Dispense enough solvent from the solvent bottle to fill the vessel to the "min" line (about 50 mL).

- Press  to pre-titrate the solvent and the titration vessel moisture. Allow the background drift rate to stabilize before proceeding to the next step.

### ANALYSIS

- Fill the syringe and needle with sample.
- Weigh the syringe, needle and oil.
- Press . You will be prompted to enter the sample size.
- Dispense 3.0 g to 5.0 g of cooking oil into the titration vessel through the septum using the needle.
- Pay attention not to get any sample on the electrode or beaker wall. If necessary, swirl the titration vessel gently by hand to remove any sample on the electrode or beaker wall.
- Clear the needle of residual sample by intaking a small volume of air from the titration vessel. If a "hanging drop" of sample is seen on the end of the needle, dip the end of the needle briefly in the solvent.
- Remove the needle from the titration vessel and weigh the syringe again in order to determine the added sample mass (by difference of the two measurements.)
- Use the numeric keypad to enter the exact weight and press  to start the analysis.
- At the end of the titration the **Result** screen is displayed. The results are expressed in ppm of water.
- Replace the solvent after 3 to 4 titrations, or if phase-separation occurs.

**METHOD PARAMETERS**

Name: Moisture in Cooking Oil  
 Method Revision: 1.1  
 Type: Sample Analysis  
 Predisensing Amount: None  
 Pre-Analysis Stir Time: 15 Sec  
 Stirring Speed: 900 RPM  
 Stirbar Type: Medium  
 Drift Entry: Automatic  
 Solvent: CHCl<sub>3</sub> MeOH 1:1  
 Sample Parameters:  
   Sample Determ.: Normal  
   Sample Name: Oil  
   Sample Type: Mass  
   Sample Size: 4.0000 g  
 Titrant: Composite 1  
   Titrant Type: one-component  
   Nominal Titrant Conc.: 1.0000 mg/mL  
   Std. Titrant Conc.: 1.0000 mg/mL  
   Date/Time: Apr 02, 2019 11:45  
   Titrant Age Reminder: 2d:00h:00m  
 Control Parameters:  
   Start Mode: Cautious  
   Standby Mode: Enabled  
   Standby Duration: 12:00 [hh:mm]  
   Imposed Current: 20 µA  
   Minimum Dose: 1.000 µL  
   Maximum Dose: 30.000 µL  
   Max Dosing Mode: Disabled  
   Timed Increment: 1 second  
   End Point Value: 180.0 mV  
   Signal Averaging: 3 Readings  
   Flow Rate: 10.0 mL/min  
 Termination Parameters:  
   Maximum Duration: 900 sec  
   Maximum Titrant Volume: 10.000 mL  
   Term. Criterion: Relative Drift  
   Relative Drift: 10.0 µg/min  
 Result Unit: ppm  
 Significant Figures: XXXXX

**CALCULATIONS**

Calculations:  
 Titrant units: mg/mL  
 Titrant volume consumed: V (mL)  
 Final results units: ppm  
 Titrant concentration: 1.0000 mg/mL  
 Sample mass: 4.0000 g

$$\text{ppm} = \frac{V \times 1.0000 \times 1000}{4.0000}$$

**RESULTS**

Method Name: Moisture in Cooking Oil  
 Time & Date: Apr 03, 2019 12:00  
 Sample Size: 4.0296 g  
 Std. Titrant Conc.: 1.0000 mg/mL  
 Drift Value: 3.4 µg/min  
 End Point Volume: 2.6808 mL  
 Result: 664 ppm  
 Titration Duration: 6:30 [mm:ss]  
 Estimated Cell Volume: 58.11 mL  
 Titration went to Completion  
 Operator Name:  
 Analyst Signature: \_\_\_\_\_

## HI8106EN MOISTURE DETERMINATION IN BUTTER

### By External Dissolution

#### DESCRIPTION

Method for the determination of moisture in butter by external dissolution. The results are expressed in % mass and should be between 15 and 20 %.

#### ELECTRODE

- HI76320 Dual Platinum Pin Electrode





#### REAGENTS



- 5 mg/mL one-component Karl Fischer volumetric titrant
- Dry methanol
- Dry chloroform

#### ACCESSORIES

- 1 mL syringe (clean and dry)
- 22-gauge, 6" non-coring septum penetration needle (clean and dry)
- Solvent bottle, GL45 thread
- 100 mL dissolution bottle with septum
- Magnetic stirrer and stirbar

#### EXTERNAL DISSOLUTION PROCEDURE



- To an external dissolution bottle with septum, add a magnetic stir bar. Weigh the bottle and record this value.
- Add 15 g of dry methanol and 25 g of dry chloroform to the bottle and stir for 15 to 20 minutes.
- Follow *HI8301EN Solvent w/ 5 mg/mL 1-comp.* to determine the moisture content of the solvent mixture.
- Enter the solvent moisture concentration by pressing  then Sample Parameters, External Solvent Concentration. Use the numeric keypad to enter the exact concentration. Press  or .
- Weigh the dissolution bottle to determine the weight of the remaining solvent (by subtracting the empty bottle mass). Enter the exact mass in Sample Parameters, External Solvent Size. Use the numeric keypad to enter the exact mass. Press  or .
- Add 2.0 to 4.0 g of butter to the bottle. Weigh the bottle to determine the exact dissolved sample weight. Enter the exact mass in Sample Parameters,

Dissolved Sample Size. Use the numeric keypad to enter the exact mass. Press  or .

- Replace the cap and mix for 20 to 30 minutes, to dissolve the sample. The resulting solution will be used to determine the water content.

**Note:** *Titrate the solution immediately.*

#### DEVICE PREPARATION

- Connect the solvent bottle top assembly to the bottle of methanol according to the manual.
- Assemble the titration vessel according to the instruction manual.
- Press  from the main screen. Use the arrow keys to highlight HI8106EN Moisture in Butter and press .
- Install a 5 mL burette filled with 5 mg/mL one-component Karl Fischer volumetric titrant and verify that no air bubbles are present in the burette or tubing. If necessary, prime until all air has been removed completely.
- To determine the exact concentration of the titrant follow *HI8001EN 5mg/mL Stdz w/water std* or *HI8011EN 5mg/mL Stdz w/tartrate*.
- Dispense enough methanol from the solvent bottle to fill the vessel to the "min" line (about 50 mL).
- Press  to pre-titrate the titration solvent and the titration vessel moisture. Allow the background drift rate to stabilize before proceeding to the next step.
- Stop stirring the dissolution bottle and allow any particulate matter to settle.

#### ANALYSIS

- Fill the syringe and needle with supernatant through the septum on the dissolution bottle.
- Weigh the syringe, needle and supernatant.
- Press  You will be prompted to enter the sample size.
- Dispense 0.500 g to 1.000 g of sample solution into the titration vessel through the septum using the needle.

- Pay attention not to get any sample on the electrode or beaker wall. If necessary, swirl the titration vessel gently by hand to remove any sample on the electrode or beaker wall.
- Clear the needle of residual sample by intaking a small volume of air from the titration vessel. If a “hanging drop” of sample is seen on the end of the needle, dip the end of the needle briefly in the solvent.
- Remove the needle from the titration vessel and weigh the syringe again in order to determine

the added sample mass (by difference of the two measurements.)

- Use the numeric keypad to enter the exact weight and press  to start the analysis.
- At the end of the titration the Result screen is displayed. The results are expressed in % mass of water.
- Replace the solvent after 10 to 12 titrations.

## METHOD PARAMETERS

Name: Moisture in Butter  
 Method Revision: 1.1  
 Type: Sample Analysis  
 Predispensing Amount: None  
 Pre-Analysis Stir Time: 10 Sec  
 Stirring Speed: 900 RPM  
 Stirbar Type: Medium  
 Drift Entry: Automatic  
 Solvent: Methanol  
 Sample Parameters:  
 Sample Determ.: External Dissolution  
 Sample Name: Butter  
 Sample Size: 0.7500 g  
 External Solvent Size: 40.0000 g  
 External Solvent Conc.: 0.0100 %  
 Extracted Sample Size: 3.0000 g  
 Titrant: Composite 5  
 Titrant Type: one-component  
 Nominal Titrant Conc.: 5.0000 mg/mL  
 Std. Titrant Conc.: 5.0000 mg/mL  
 Date/Time: Apr 02, 2019 11:45  
 Titrant Age Reminder: 2d:00h:00m  
 Control Parameters:  
 Start Mode: Normal  
 Standby Mode: Enabled  
 Standby Duration: 12:00 [hh:mm]  
 Imposed Current: 20 µA  
 Minimum Dose: 0.500 µL  
 Maximum Dose: 40.000 µL  
 Max Dosing Mode: Disabled  
 Timed Increment: 1 second  
 End Point Value: 180.0 mV  
 Signal Averaging: 3 Readings  
 Flow Rate: 10.0 mL/min  
 Termination Parameters:  
 Maximum Duration: 720 sec  
 Maximum Titrant Volume: 10.000 mL  
 Term. Criterion: Relative Drift  
 Relative Drift: 15.0 µg/min  
 Result Unit: %  
 Significant Figures: XXXXX

## CALCULATIONS

Titrant units: mg/mL  
 Titrant volume consumed: V (mL)  
 Final results units: % Mass  
 Titrant concentration: 5.0000 mg/mL  
 External Solvent Size: 40.0000 g  
 External Solvent Conc.: 0.0100 %  
 Extracted Sample Size: 3.0000 g  
 Sample mass: 0.7500 g

$$\% \text{Mass} = \frac{40.000}{3.000} \times \frac{\left( \frac{5.0000 \times V}{0.7500 \times 10} \right) - 0.0100}{100 - \left( \frac{5.0000 \times V}{0.7500 \times 10} \right)} \times 100$$

## RESULTS

Method Name: Moisture in Butter  
 Time & Date: Apr 03, 2019 12:00  
 Sample Size: 0.7841 g  
 Std. Titrant Conc.: 5.0000 mg/mL  
 Drift Value: 4.6 µg/min  
 End Point Volume: 2.4497 mL  
 External Solvent Size: 38.4979 g  
 External Solvent Conc.: 0.0167 %  
 Extracted Sample Size: 3.1222 g  
 Result: 19.3903 %  
 Titration Duration: 6:54 [mm:ss]  
 Estimated Cell Volume: 61.0 mL  
 Titration went to Completion  
 Operator Name:  
 Analyst Signature: \_\_\_\_\_

## HI8107EN MOISTURE DETERMINATION IN MARGARINE

### By External Dissolution

#### DESCRIPTION

Method for the determination of moisture in margarine by external dissolution. The results are expressed in % mass and should be between 15 and 30 %.

#### ELECTRODE

- HI76320 Dual Platinum Pin Electrode





#### REAGENTS



- 5 mg/mL one-component Karl Fischer volumetric titrant
- Dry methanol
- Dry chloroform

#### ACCESSORIES

- 1 mL syringe (clean and dry)
- 22-gauge, 6" non-coring septum penetration needle (clean and dry)
- Solvent bottle, GL45 thread
- 100 mL dissolution bottle with septum
- Magnetic stirrer and stirbar

#### EXTERNAL DISSOLUTION PROCEDURE



- To an external dissolution bottle with septum, add a magnetic stir bar. Weigh the bottle and record this value.
- Add 20 g of dry methanol and 20 g of dry chloroform to the bottle and stir for 15 to 20 minutes.
- Follow *HI8301EN Solvent w/ 5 mg/mL 1-comp.* to determine the moisture content of the solvent mixture.
- Enter the solvent moisture concentration by pressing  then Sample Parameters, External Solvent Concentration. Use the numeric keypad to enter the exact concentration. Press  or .
- Weigh the dissolution bottle to determine the weight of the remaining solvent (by subtracting the empty bottle mass). Enter the exact mass in Sample Parameters, External Solvent Size. Use the numeric keypad to enter the exact mass. Press  or .
- Add 2.0 to 4.0 g of margarine to the bottle. Weigh the bottle to determine the exact dissolved sample

weight. Enter the exact mass in Sample Parameters, Dissolved Sample Size. Use the numeric keypad to enter the exact mass. Press  or .

- Replace the cap and mix for 20 to 30 minutes to dissolve the sample. The resulting solution will be used to determine the water content.

**Note:** *Titrate the solution immediately.*

#### DEVICE PREPARATION

- Connect the solvent bottle top assembly to the bottle of methanol according to the manual.
- Assemble the titration vessel according to the instruction manual.
- Press  from the main screen. Use the arrow keys to highlight *HI8107EN Moisture in Margarine* and press .
- Install a 5 mL burette filled with 5 mg/mL one-component Karl Fischer volumetric titrant and verify that no air bubbles are present in the burette or tubing. If necessary, prime until all air has been removed completely.
- For the determination of the exact concentration of the titrant, follow HI8001EN 5mg/mL Stdz w/water std or HI8011EN 5mg/mL Stdz w/tartrate.
- Dispense enough methanol from the solvent bottle to fill the vessel to the "min" line (about 50 mL).
- Press  to pre-titrate the titration solvent and the titration vessel moisture. Allow the background drift rate to stabilize before proceeding to the next step.
- Stop stirring the extraction bottle and allow any particulate matter to settle.

#### ANALYSIS

- Fill the syringe and needle with the supernatant through the septum on the dissolution bottle.
- Weigh the syringe, needle and supernatant.
- Press . You will be prompted to enter the sample size.
- Dispense 0.500 g to 1.000 g of supernatant into the titration vessel through the septum using the needle.

- Pay attention not to get any sample on the electrode or beaker wall. If necessary, swirl the titration vessel gently by hand to remove any sample on the electrode or beaker wall.
- Clear the needle of residual sample by intaking a small volume of air from the titration vessel. If a “hanging drop” of sample is seen on the end of the needle, dip the end of the needle briefly in the solvent.
- Remove the needle from the titration vessel and weigh the syringe again in order to determine the added sample mass (by difference of the two measurements.)
- Use the numeric keypad to enter the exact weight and press **enter** to start the analysis.
- At the end of the titration the Result screen is displayed. The results are expressed in **% mass** of water.
- Replace the solvent after 12 to 16 titrations.

## METHOD PARAMETERS

Name: Moisture in Margarine  
 Method Revision: 1.1  
 Type: Sample Analysis  
 Predisensing Amount: None  
 Pre-Analysis Stir Time: 10 Sec  
 Stirring Speed: 900 RPM  
 Stirbar Type: Medium  
 Drift Entry: Automatic  
 Solvent: Methanol

Sample Parameters:  
 Sample Determ.: External Extraction  
 Sample Name: Margarine  
 Sample Size: 0.7500 g  
 External Solvent Size: 40.0000 g  
 External Solvent Conc.: 0.0100 %  
 Extracted Sample Size: 3.0000 g

Titrant:  
 Composite 5  
 Titrant Type: one-component  
 Nominal Titrant Conc.: 5.0000 mg/mL  
 Std. Titrant Conc.: 5.0000 mg/mL  
 Date/Time: Apr 02, 2019 11:45  
 Titrant Age Reminder: 2d:00h:00m

Control Parameters:  
 Start Mode: Normal  
 Standby Mode: Enabled  
 Standby Duration: 12:00 [hh:mm]  
 Imposed Current: 20  $\mu$ A  
 Minimum Dose: 1.00  $\mu$ L  
 Maximum Dose: 50.000  $\mu$ L  
 Max Dosing Mode: Disabled  
 Timed Increment: 1 second  
 End Point Value: 180.0 mV  
 Signal Averaging: 3 Readings  
 Flow Rate: 10.0 mL/min

Termination Parameters:  
 Maximum Duration: 720 sec  
 Maximum Titrant Volume: 10.000 mL  
 Term. Criterion: Relative Drift  
 Relative Drift: 15.0  $\mu$ g/min  
 Result Unit: %  
 Significant Figures: XXXXX

## CALCULATIONS

Titrant units: mg/mL  
 Titrant volume consumed: V (mL)  
 Final results units: % Mass  
 Titrant concentration: 5.0000 mg/mL  
 External Solvent Size: 40.0000 g  
 External Solvent Conc.: 0.0100 %  
 Extracted Sample Size: 3.0000 g  
 Sample mass: 0.7500 g

$$\% \text{Mass} = \frac{40.000}{1.000} \times \frac{\left( \frac{5.0000 \times V}{0.7500 \times 10} \right) - 0.0100}{100 - \left( \frac{5.0000 \times V}{0.7500 \times 10} \right)} \times 100$$

## RESULTS

Method Name: Moisture in Margarine  
 Time & Date: Apr 03, 2019 12:00  
 Sample Size: 0.7402 g  
 Std. Titrant Conc.: 5.0000 mg/mL  
 Drift Value: 4.1  $\mu$ g/min  
 End Point Volume: 3.1402 mL  
 External Solvent Size: 39.9262 g  
 External Solvent Conc.: 0.0141 %  
 Extracted Sample Size: 3.1118 g  
 Result: 27.6339 %  
 Titration Duration: 5:30 [mm:ss]  
 Estimated Cell Volume: 64.4 mL  
 Titration went to Completion  
 Operator Name:  
 Analyst Signature: \_\_\_\_\_

## HI8108EN MOISTURE DETERMINATION IN MAYONNAISE

### DESCRIPTION

Method for the determination of moisture in Mayonnaise by external extraction. The results are expressed in % mass and should be between 40 and 60 %.

### ELECTRODE

- HI76320 Dual Platinum Pin Electrode





### REAGENTS



- 5 mg/mL one-component Karl Fischer volumetric titrant
- Dry methanol

### ACCESSORIES

- 1 mL syringe (clean and dry)
- 22-gauge, 6" non-coring septum penetration needle (clean and dry)
- Solvent bottle, GL45 thread
- 100 mL extraction bottle with septum
- Magnetic stirrer and stirbar

### EXTERNAL EXTRACTION PROCEDURE



- To an external dissolution bottle with septum, add a magnetic stir bar. Weigh the bottle and record this value.
- Add 40 g of dry methanol to the bottle and stir for 5 minutes.
- Follow *HI8301EN Solvent w/ 5 mg/mL 1-comp.* to determine the moisture content of the solvent mixture.
- Enter the solvent moisture concentration by pressing  then Sample Parameters, External Solvent Concentration. Use the numeric keypad to enter the exact concentration. Press  or .
- Weigh the dissolution bottle to determine the weight of the remaining solvent (by subtracting the empty bottle mass). Enter the exact mass in Sample Parameters, External Solvent Size. Use the numeric keypad to enter the exact mass. Press  or .
- Add 0.8 to 1.2 g of mayonnaise to the bottle. Weigh the bottle to determine the exact dissolved sample weight. Enter the exact mass in Sample Parameters,

Dissolved Sample Size. Use the numeric keypad to enter the exact mass. Press  or .

- Replace the cap and mix for 20 to 30 minutes to dissolve the sample. The resulting solution will be used to determine the water content.

**Note:** *Titrate the solution immediately.*

### DEVICE PREPARATION

- Connect the solvent bottle top assembly to the bottle of methanol according to the manual.
- Assemble the titration vessel according to the instruction manual.
- Press  from the main screen. Use the arrow keys to highlight *HI8108EN Moisture in Mayonnaise* and press .
- Install a 5 mL burette filled with 5 mg/mL one-component Karl Fischer volumetric titrant and verify that no air bubbles are present in the burette or tubing. If necessary, prime until all air has been removed completely.
- For the determination of the exact concentration of the titrant, follow *HI8001EN 5mg/mL Stdz w/ water std* or *HI8011EN 5mg/mL Stdz w/tartrate*.
- Dispense enough methanol from the solvent bottle to fill the vessel to the "min" line (about 50 mL).
- Press  to pre-titrate the titration solvent and the titration vessel moisture. Allow the background drift rate to stabilize before proceeding to the next step.
- Stop stirring the sample in the extraction bottle and allow any particulate matter to settle.

### ANALYSIS

- Fill the syringe and needle with the supernatant through the septum on the dissolution bottle.
- Weigh the syringe, needle and supernatant.
- Press . You will be prompted to enter the sample size.
- Dispense 0.500 g to 1.000 g of supernatant into the titration vessel through the septum using the needle.
- Pay attention not to get any sample on the electrode or beaker wall. If necessary, swirl the titration

vessel gently by hand to remove any sample on the electrode or beaker wall.

- Clear the needle of residual sample by intaking a small volume of air from the titration vessel. If a “hanging drop” of sample is seen on the end of the needle, dip the end of the needle briefly in the solvent.
- Remove the needle from the titration vessel and weigh the syringe again in order to determine

the added sample mass (by difference of the two measurements.)

- Use the numeric keypad to enter the exact weight and press  to start the analysis.
- At the end of the titration the Result screen is displayed. The results are expressed in % mass of water.
- Replace the solvent after 12 to 16 titrations.

## METHOD PARAMETERS

```
Name:           Moisture in Mayonnaise
Method Revision: 1.1
Type:           Sample Analysis
Predisensing Amount: None
Pre-Analysis Stir Time: 10 Sec
Stirring Speed: 900 RPM
Stirbar Type:   Medium
Drift Entry:    Automatic
Solvent:        Methanol
Sample Parameters:
  Sample Determ.: External Extraction
  Sample Name:    Mayonnaise
  Sample Size:    0.7500 g
  External Solvent Size: 40.0000 g
  External Solvent Conc.: 0.0100 %
  Extracted Sample Size: 1.0000 g
Titrant:        Composite 5
Titrant Type:   one-component
Nominal Titrant Conc.: 5.0000 mg/mL
Std. Titrant Conc.: 5.0000 mg/mL
Date/Time:     Apr 02, 2019 11:45
Titrant Age Reminder: 2d:00h:00m
Control Parameters:
  Start Mode:    Normal
  Standby Mode:  Enabled
  Standby Duration: 12:00 [hh:mm]
  Imposed Current: 20 µA
  Minimum Dose:  0.500 µL
  Maximum Dose:  20.000 µL
  Max Dosing Mode Disabled
  Timed Increment: 1 second
  End Point Value: 180.0 mV
  Signal Averaging: 3 Readings
  Flow Rate:     10.0 mL/min
Termination Parameters:
  Maximum Duration: 720 sec
  Maximum Titrant Volume: 10.000 mL
  Term. Criterion:  Relative Drift
  Relative Drift:   10.0 µg/min
Result Unit:       %
Significant Figures XXXXX
```

## CALCULATIONS

```
Titrant units:           mg/mL
Titrant volume consumed: V (mL)
Final results units:     % Mass
Titrant concentration:  5.0000 mg/mL
External Solvent Size:   40.0000 g
External Solvent Conc.:  0.0100 %
Extracted Sample Size:   1.0000 g
Sample mass:             0.7500 g
```

$$\% \text{Mass} = \frac{40.000}{3.000} \times \frac{\left( \frac{5.0000 \times V}{0.7500 \times 10} \right) - 0.0100}{100 - \left( \frac{5.0000 \times V}{0.7500 \times 10} \right)} \times 100$$

## RESULTS

```
Method Name:  Moisture in Mayonnaise
Time & Date:   Apr 03, 2019 12:00
Sample Size:   0.7500 g
Std. Titrant Conc.: 5.0000 mg/mL
Drift Value:   4.6 µg/min
End Point Volume: 2.2010 mL
External Solvent Size: 40.0000 g
External Solvent Conc.: 0.0100 %
Extracted Sample Size: 1.0000 g
Result:        58.9770 %
Titration Duration: 7:18 [mm:ss]
Estimated Cell Volume: 60.0 mL
Titration went to Completion
Operator Name:
Analyst Signature: _____
```

## HI8201EN MOISTURE DETERMINATION IN SHAMPOO

## DESCRIPTION

Method for the determination of water in shampoo. The results are expressed in % mass and should be between 70 and 90 %.

## ELECTRODE

- HI76320 Dual Platinum Pin Electrode



## REAGENTS

- 5 mg/mL one-component Karl Fischer volumetric titrant
- Dry methanol



## ACCESSORIES

- 1 mL syringe (clean and dry)
- 18-gauge, 6" non-coring septum penetration needle (clean and dry)
- Solvent bottle, GL45 thread

## DEVICE PREPARATION

- Connect the solvent bottle top assembly to the bottle of methanol according to the manual.
- Assemble the titration vessel according to the instruction manual.
- Install a 5 mL burette filled with 5 mg/mL one-component Karl Fischer volumetric titrant and verify that no air bubbles are present in the burette or tubing. If necessary, prime until all air has been removed completely.
- Press  from the main screen. Use the arrow keys to highlight *HI8201EN Moisture in Shampoo* and press .
- For the determination of the exact concentration of the titrant, follow *HI8001EN 5mg/mL Stdz w/ water std* or *HI8011EN 5mg/mL Stdz w/tartrate*.
- Dispense enough methanol from the solvent bottle to fill the vessel to the "min" line (about 50 mL).
- Press  to pre-titrate the solvent and the titration vessel moisture. Allow the background drift rate to stabilize before proceeding to the next step.

## ANALYSIS

- Fill the syringe and needle with sample.
- Weigh the syringe, needle and shampoo.
- Press . You will be prompted to enter the sample size.
- Dispense 0.015 g to 0.020 g of shampoo into the titration vessel through the septum using the needle.
- Pay attention not to get any sample on the electrode or beaker wall. If necessary, swirl the titration vessel gently by hand to remove any sample on the electrode or beaker wall.
- Clear the needle of residual sample by intaking a small volume of air from the titration vessel. If a "hanging drop" of sample is seen on the end of the needle, dip the end of the needle briefly in the solvent.
- Remove the needle from the titration vessel and weigh the syringe again in order to determine the added sample mass (by difference of the two measurements.)
- Use the numeric keypad to enter the exact weight and press  to start the analysis.
- At the end of the titration the **Result** screen is displayed. The results are expressed in % mass of water.

**METHOD PARAMETERS**

Name: Moisture in Shampoo  
 Method Revision: 1.1  
 Type: Sample Analysis  
 Predispensing Amount: 40 %  
 Pre-Analysis Stir Time: 15 Sec  
 Stirring Speed: 900 RPM  
 Stirbar Type: Medium  
 Drift Entry: Automatic  
 Solvent: Methanol  
 Sample Parameters:  
   Sample Determ.: Normal  
   Sample Name: Shampoo  
   Sample Type: Mass  
   Sample Size: 0.0200 g  
 Titrant: Composite 5  
   Titrant Type: one-component  
   Nominal Titrant Conc.: 5.0000 mg/mL  
   Std. Titrant Conc.: 5.0000 mg/mL  
   Date/Time: Apr 02, 2019 11:45  
   Titrant Age Reminder: 2d:00h:00m  
 Control Parameters:  
   Start Mode: Normal  
   Standby Mode: Enabled  
   Standby Duration: 12:00 [hh:mm]  
   Imposed Current: 20 µA  
   Minimum Dose: 0.500 µL  
   Maximum Dose: 20.000 µL  
   Max Dosing Mode: Disabled  
   Timed Increment: 1 second  
   End Point Value: 180.0 mV  
   Signal Averaging: 3 Readings  
   Flow Rate: 10.0 mL/min  
 Termination Parameters:  
   Maximum Duration: 600 sec  
   Maximum Titrant Volume: 10.000 mL  
   Term. Criterion: Relative Drift  
   Relative Drift: 10.0 µg/min  
 Result Unit: %  
 Significant Figures: XXXXX

**CALCULATIONS**

Titrant units: mg/mL  
 Titrant volume consumed: V (mL)  
 Final results units: % Mass  
 Titrant concentration: 5.0000 mg/mL  
 Sample mass: 0.0200 g

$$\% \text{ Mass} = \frac{V \times 5.0000}{0.020 \times 10}$$

**RESULTS**

Method Name: Moisture in Shampoo  
 Time & Date: Apr 03, 2019 12:00  
 Sample Size: 0.0200 g  
 Std. Titrant Conc.: 5.0000 mg/mL  
 Drift Value: 5.4 µg/min  
 End Point Volume: 3.2010 mL  
 Result: 79.8207 %  
 Titration Duration: 7:19 [mm:ss]  
 Estimated Cell Volume: 106.37 mL  
 Titration went to Completion  
 Operator Name:  
 Analyst Signature: \_\_\_\_\_

## HI8202EN MOISTURE DETERMINATION IN HAND CREAM

### DESCRIPTION

Method for the determination of moisture in hand cream. The results are expressed in % mass and should be between 50 and 75 %.

### ELECTRODE

- HI76320 Dual Platinum Pin Electrode

### REAGENTS

- 5 mg/mL one-component Karl Fischer volumetric titrant
- Dry methanol
- Dry chloroform



### ACCESSORIES

- 1 mL syringe (clean and dry)
- 18-gauge, 6" non-coring septum penetration needle (clean and dry)
- Solvent bottle, GL45 thread

### SOLVENT PREPARATION



- Prepare at least 200 mL of solvent by adding 2 part dry chloroform and 1 part dry methanol to the solvent bottle.

### DEVICE PREPARATION

- Connect the solvent bottle top assembly to the bottle of solvent according to the manual.
- Assemble the titration vessel according to the instruction manual.
- Install a 5 mL burette filled with 5 mg/mL one-component Karl Fischer volumetric titrant and verify that no air bubbles are present in the burette or tubing. If necessary, prime until all air has been removed completely.
- Press  from the main screen. Use the arrow keys to highlight HI8202EN Moisture in Hand Cream and press .
- For the determination of the exact concentration of the titrant, follow *HI8001EN 5mg/mL Stdz w/ water std* or *HI8011EN 5mg/mL Stdz w/tartrate*.
- Dispense enough solvent from the solvent bottle to fill the vessel to the "min" line (about 50 mL).

- Press  to pre-titrate the solvent and the titration vessel moisture. Allow the background drift rate to stabilize before proceeding to the next step.

### ANALYSIS

- Fill the syringe and needle with sample.
- Weigh the syringe, needle and hand cream.
- Press . You will be prompted to enter the sample size.
- Dispense 0.020 g to 0.025 g of hand cream into the titration vessel through the septum using the needle.
- Pay attention not to get any sample on the electrode or beaker wall. If necessary, swirl the titration vessel gently by hand to remove any sample on the electrode or beaker wall.
- Clear the needle of residual sample by intaking a small volume of air from the titration vessel. If a "hanging drop" of sample is seen on the end of the needle, dip the end of the needle briefly in the solvent.
- Remove the needle from the titration vessel and weigh the syringe again in order to determine the added sample mass (by difference of the two measurements.)
- Use the numeric keypad to enter the exact weight and press  to start the analysis.
- At the end of the titration the **Result** screen is displayed. The results are expressed in % mass of water.

**METHOD PARAMETERS**

Name: Moisture in Hand Cream  
 Method Revision: 1.1  
 Type: Sample Analysis  
 Predispensing Amount: 40 %  
 Pre-Analysis Stir Time: 15 Sec  
 Stirring Speed: 900 RPM  
 Stirbar Type: Medium  
 Drift Entry: Automatic  
 Solvent: CHCl3 MeOH 2:1  
 Sample Parameters:  
 Sample Determ.: Normal  
 Sample Name: Hand Cream  
 Sample Type: Mass  
 Sample Size: 0.0200 g  
 Titrant: Composite 5  
 Titrant Type: one-component  
 Nominal Titrant Conc.: 5.0000 mg/mL  
 Std. Titrant Conc.: 5.0000 mg/mL  
 Date/Time: Apr 02, 2019 11:45  
 Titrant Age Reminder: 2d:00h:00m  
 Control Parameters:  
 Start Mode: Normal  
 Standby Mode: Enabled  
 Standby Duration: 12:00 [hh:mm]  
 Imposed Current: 20 µA  
 Minimum Dose: 0.500 µL  
 Maximum Dose: 20.000 µL  
 Max Dosing Mode: Disabled  
 Timed Increment: 1 second  
 End Point Value: 180.0 mV  
 Signal Averaging: 3 Readings  
 Flow Rate: 10.0 mL/min  
 Termination Parameters:  
 Maximum Duration: 900 sec  
 Maximum Titrant Volume: 10.000 mL  
 Term. Criterion: Relative Drift  
 Relative Drift: 10.0 µg/min  
 Result Unit: %  
 Significant Figures: XXXXX

**CALCULATIONS**

Titrant units: mg/mL  
 Titrant volume consumed: V (mL)  
 Final results units: % Mass  
 Titrant concentration: 5.0000 mg/mL  
 Sample mass: 0.0200 g

$$\% \text{ Mass} = \frac{V \times 5.0000}{0.020 \times 10}$$

**RESULTS**

Method Name: Moisture Hand Cream  
 Time & Date: Apr 03, 2019 12:00  
 Sample Size: 0.0244 g  
 Std. Titrant Conc.: 5.0000 mg/mL  
 Drift Value: 5.4 µg/min  
 End Point Volume: 3.2915 mL  
 Result: 67.3125 %  
 Titration Duration: 6:48 [mm:ss]  
 Estimated Cell Volume: 53.47 mL  
 Titration went to Completion  
 Operator Name:  
 Analyst Signature: \_\_\_\_\_

## HI8301EN MOISTURE DETERMINATION IN SOLVENT WITH 5 mg/mL TITRANT (ONE-COMP)

### For External Dissolution or Extraction

#### DESCRIPTION

Method for the determination of moisture in extraction/dissolution solvent using 5 mg/mL one-component Karl Fischer volumetric titrant. The results are expressed in **% mass** and should be less than 0.1%.

#### ELECTRODE

- HI76320 Dual Platinum Pin Electrode



#### REAGENTS

- 5 mg/mL one-component Karl Fischer volumetric titrant
- Dry methanol



#### ACCESSORIES

- 1 mL syringe (clean and dry)
- 18-gauge, 6" non-coring septum penetration needle (clean and dry)
- Solvent bottle, GL45 thread

#### TITRATION PROCEDURE

- Connect the solvent bottle top assembly to the bottle of methanol according to the manual.
- Assemble the titration vessel according to the instruction manual.
- Install a 5 mL burette filled with 5 mg/mL one-component Karl Fischer volumetric titrant and verify that no air bubbles are present in the burette or tubing. If necessary, prime until all air has been removed completely.
- Press  from the main screen. Use the arrow keys to highlight *HI8301EN Solvent w/ 5mg/mL 1-comp* and press .
- For the determination of the exact concentration of the titrant, follow *HI8001EN 5mg/mL Stdz w/ water std* or *HI8011EN 5mg/mL Stdz w/tartrate*.
- Dispense enough methanol from the solvent bottle to fill the vessel to the "min" line (about 50 mL).
- Press  to pre-titrate the methanol and the titration vessel moisture. Allow the background drift rate to stabilize before proceeding to the next step.

#### ANALYSIS

- Stop stirring the solvent in the extraction/dissolution bottle.
- Fill the syringe and needle with the extraction/dissolution solvent.
- Weigh the syringe, needle and solvent.
- Press  You will be prompted to enter the sample size.
- Dispense 0.750 g to 1.000 g of solvent into the titration vessel through the septum using the needle.
- Pay attention not to get any solvent on the electrode or beaker wall. If necessary, swirl the titration vessel gently by hand to remove any sample on the electrode or beaker wall.
- Clear the needle of residual solvent by intaking a small volume of air from the titration vessel. If a "hanging drop" of solvent is seen on the end of the needle, dip the end of the needle briefly in the titration solvent.
- Remove the needle from the titration vessel and weigh the syringe again in order to determine the added sample mass (by difference of the two measurements.)
- Use the numeric keypad to enter the exact weight and press  to start the analysis.
- At the end of the titration the **Result** screen is displayed. The results are expressed in **% mass** of water. Record this value as the "External Solvent Concentration".

**METHOD PARAMETERS**

Name: Solvent w/ 5mg/mL 1-comp.  
 Method Revision: 1.1  
 Type: Sample Analysis  
 Predispensing Amount: None  
 Pre-Analysis Stir Time: 0 Sec  
 Stirring Speed: 900 RPM  
 Stirbar Type: Medium  
 Drift Entry: Automatic  
 Solvent: Methanol

Sample Parameters:  
 Sample Determ.: Normal  
 Sample Name: Solvent  
 Sample Type: Mass  
 Sample Size: 1.0000 g

Titration:  
 Titration Type: Composite 5  
 Titration Type: one-component  
 Nominal Titration Conc.: 5.0000 mg/mL  
 Std. Titration Conc.: 5.0000 mg/mL  
 Date/Time: Apr 02, 2019 11:45  
 Titration Age Reminder: 2d:00h:00m

Control Parameters:  
 Start Mode: Cautious  
 Standby Mode: Enabled  
 Standby Duration: 12:00 [hh:mm]  
 Imposed Current: 20 µA  
 Minimum Dose: 0.250 µL  
 Maximum Dose: 5.000 µL  
 Max Dosing Mode: Disabled  
 Timed Increment: 1 second  
 End Point Value: 180.0 mV  
 Signal Averaging: 3 Readings  
 Flow Rate: 10.0 mL/min

Termination Parameters:  
 Maximum Duration: 600 sec  
 Maximum Titration Volume: 5.000 mL  
 Term. Criterion: Relative Drift  
 Relative Drift: 10.0 µg/min  
 Result Unit: %  
 Significant Figures: XXXXX

**CALCULATIONS**

Titration units: mg/mL  
 Titration volume consumed: V (mL)  
 Final results units: % Mass  
 Titration concentration: 5.0000 mg/mL  
 Sample mass: 1.0000 g

$$\text{Mass} = \frac{V \times 5.0000}{1.0000 \times 10}$$

**RESULTS**

Method Name: Solvent w/ 5mg/mL 1-comp.  
 Time & Date: Apr 03, 2019 12:00  
 Sample Size: 0.9580 g  
 Std. Titration Conc.: 5.0000 mg/mL  
 Drift Value: 4.0 µg/min  
 End Point Volume: 0.1157 mL  
 Result: 0.0595 %  
 Titration Duration: 2:06 [mm:ss]  
 Estimated Cell Volume: 57.5 mL  
 Titration went to Completion  
 Operator Name:  
 Analyst Signature: \_\_\_\_\_



## PART 4:

## TITRATION THEORY



## 1. TITRATION THEORY

### 1.1. INTRODUCTION TO TITRATIONS

A titration is a quantitative, volumetric procedure used in analytical chemistry to determine the concentration of an analyte (the species being measured) in solution. The concentration of the analyte is determined by slowly adding a titrant (reagent) to the solution. As the titrant is added, a chemical reaction occurs between the titrant and the analyte. Titration reactions are relatively fast, simple reactions that can be expressed using a chemical equation. The titration reaction continues as the titrant is added until all of the analyte is consumed and the analyte reacts completely and quantitatively with the titrant.

The point at which all of the analyte has been reacted is called the equivalence point, also known as the theoretical or stoichiometric end point. This point is accompanied by an abrupt physical change in the solution, which sharply defines the end point of the reaction. The physical change associated with the titration end point can be produced by the titrant or an indicator, and can be detected either visually or by some other physical measurement.

Titration cannot be used to determine the quantity of all analytes. The chemical reaction between the titrant and analyte must fulfill four requirements:

- The reaction must be fast and occur within approximately one second after the titrant has been added
- The reaction must go to completion
- The reaction must have well-known stoichiometry (reaction ratios)
- A convenient end point or inflection point

Titration is highly precise and can provide many advantages over alternative methods. Titrations are quickly performed and require relatively simple apparatus and instrumentation.

### 1.2. USES OF TITRATIONS

Titration can be used in many applications, including:

- Acid content of plant effluents, food (e.g. cheese and wine), plating and etching baths, petroleum products, drugs
- Base content of fertilizer (containing ammonia), bleach, minerals
- Hardness in water
- Metal content of alloys, minerals, ores, clays, waters, plating baths, paints, paper, plant materials, biological fluids, petroleum products
- Moisture content in foodstuff, petrochemicals, pharmaceutical products, and plastics
- Redox reagent concentrations such as available chlorine in potable water, peroxide, traces of oxidants and reductants in food, reductants in high temperature or high pressure boiler water, vitamin analysis

### 1.3. ADVANTAGES AND DISADVANTAGES OF TITRATIONS

Some advantages of titration as an analytical technique are:

- More precise results than many instrumental methods, such as measurement by electrode, the accuracy of the measurement is up to 0.1%
- Simple methods, reasonable capital costs, and easy training
- Suitability to measure major components of a mixture or product
- Automation can reduce time and labor spent on each analysis

Some disadvantages of titration are:

- The time it takes to prepare standards and titrants
- Good technique is required to achieve precise results (training and practice required)
- Not suitable for determining trace or minor components of a mixture or product
- Limited dynamic range, it may require additional sample preparations (dilution) and repeat analyses

## 2. TYPES OF TITRATIONS

### 2.1. TITRATIONS ACCORDING TO THE MEASUREMENT METHOD

#### 2.1.1. AMPEROMETRIC TITRATIONS

An amperometric titration is performed by placing two electrodes (often a metal ion selective electrode and a reference electrode) into the sample solution and keeping the potential of the metal electrode at a selected voltage. The current that flows, due to the oxidation or reduction of a reactant or product, is plotted vs. volume of titrant to provide the titration curve and locate the equivalence point. Changes in the current are due to changes in the concentration of a particular species (being oxidized or reduced at the electrode).

Generally the reaction between the analyte and titrant forms a new species. Depending on the titration, the reactants are electroactive and the products are not, or vice-versa. Amperometric titration curves look like two straight lines intersecting at the equivalence point, this is due to the change in the electroactivity of the solution.

Many metal ions can be amperometrically titrated using a precipitation, complexation or redox reaction. Some metal ions and species that can be determined in this manner include silver, barium, halides, potassium, magnesium, palladium, molybdate, sulfate, tungstate, zinc, bismuth, cadmium, fluoride, indium, thallium, iodine, and gold.

Figure 1 shows four amperometric titrations and their end points. In graph **A** the analyte is electroactive and gives current but the reacted species does not. In **B** the reactant is not active but the titrant is. In **C** both the analyte and titrant are active and both give current flow. Graph **D** shows the same situation as **B**; however, the current has an opposite sign (the titrant is reduced).

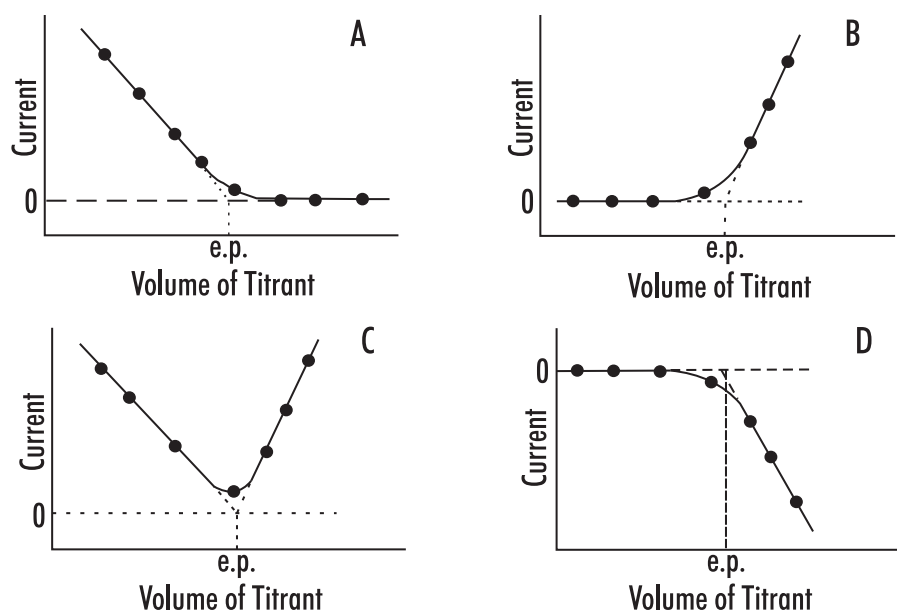

Figure 1

#### 2.1.2. POTENTIOMETRIC TITRATIONS

Potentiometric titrations are done by measuring the voltage across the solution using an electrode system. An electrode system consists of an indicator electrode and a reference electrode. As titrant is added, the variations in the potential of the indicator electrode, with respect to the reference electrode, are monitored to show the progress of the titration.

Potentiometry is the measurement of a potential under conditions of zero current flow. The measured potential can then be used to determine the analytical quantity of interest, generally a component concentration of the analyte solution.

The potential that develops in the electrochemical cell is the result of the free energy change that would occur if the chemical phenomena were to proceed until the equilibrium condition has been satisfied.

There are many types of titrations where potentiometry can be used, e.g. pH electrodes for acid-base titrations, platinum ORP electrodes in redox titrations, ion selective electrodes, such as chloride or fluoride for a specific ion titration, and silver electrodes for argentometric (silver-based) titrations.

### 2.1.3. SPECTROPHOTOMETRIC TITRATIONS

The name comes from the method used to detect the end point of the titration, not its chemistry. Highly colored indicators that change color during the course of the titration are available for many titrations. More accurate data on the titration curve can be obtained if the light absorption is monitored instrumentally using a light source, a simple monochromator and a photodetector, rather than visually determining the color or light absorption change. Light absorption by either an indicator or by one of the reactants or products can be used to monitor the titration.

Figure 2, shows two titration curves. In graph **A** the absorption of a metal-indicator complex is being monitored. The absorption is constant while the metal is complexed by the EDTA titrant. The metal indicator complex was stripped, causing a sharp break in the titration curve. The point where all the metal is complexed and stripped from the indicator is the equivalence point. This point is marked by "e.p." on the graph.

In the second titration curve, graph **B**, the metal complex is being measured while being titrated with EDTA. The new complex being formed is not colored and does not absorb light. The extrapolated intersection of the two lines determines the equivalence point.

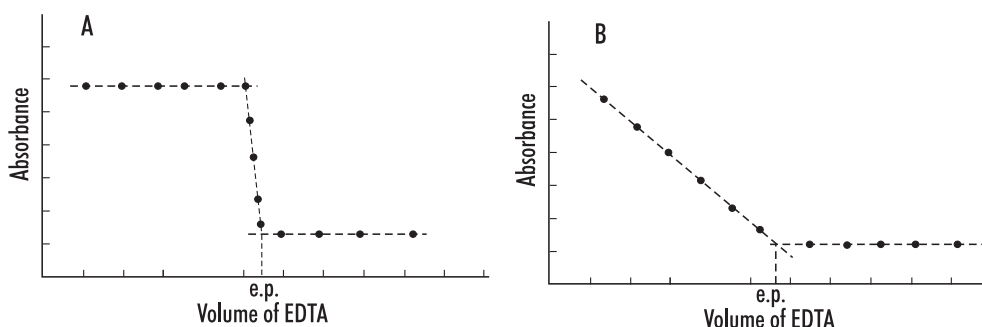

Figure 2

## 2.2. TITRATIONS ACCORDING TO THE REACTION TYPE

### 2.2.1. KARL FISCHER TITRATIONS

This method is based on a well-defined chemical reaction between water and the Karl Fischer reagent. The chemistry provides excellent specificity for water determination. The method can be used to determine free and bound water in a sample matrix. The Karl Fischer method is widely considered to produce the most rapid, accurate and reproducible results and has the largest detectable concentration range spanning 1 ppm to 100%.

The determination of water content is one of the most commonly practiced methods in laboratories around the world. Knowledge of water content is critical to understanding chemical and physical properties of materials and ascertaining product quality. Water content determination is conducted on many sample types including pharmaceuticals and cosmetics, foods and natural products, organic and inorganic compounds, chemicals, solvents and gases, petroleum and plastic products as well as paints and adhesives. The KF method is verifiable and can be fully documented. As a result, Karl Fischer titration is the standard method for analysis of water in a multitude of samples as specified by numerous organizations including the Association of Official Analytical Chemists, the United States and European Pharmacopoeia, ASTM, American Petroleum Institute, British Standards and DIN.

### 2.2.1.1. HISTORY OF KARL FISCHER TITRATIONS

Water determination by Karl Fischer titration is based on the reaction described by Bunsen in 1853 in which sulfur dioxide is oxidized by iodine in the presence of water.

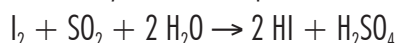

In Karl Fischer's 1935 article, "a new procedure for the titration of water", he presented a modified form of the Bunsen reaction adapted for use in determining the water content of non-aqueous solutions. His titrations were conducted in methanol in the presence of excess sulfur dioxide and pyridine in order to neutralize the acidic reaction products and drive the reaction to completion.



Two key developments have since lead to the currently accepted description of the Karl Fischer reaction. First, pyridine acts as a pH buffer and does not play a direct role in the reaction. This has allowed reagent formulators to replace pyridine with bases which are both less toxic and result in pH ranges that facilitate faster and more accurate titrations. Second, the species that reacts with water is not sulfur dioxide but the monomethyl sulfite ion resulting from the reaction between sulfur dioxide and methanol. Subsequently, researchers showed that higher alcohols can be used in place of methanol. The Karl Fischer reaction can therefore be described by the following generalized reaction sequence in which the  $H_2O$ ,  $I_2$ ,  $SO_2$  and RN species react in a 1:1:1:3 stoichiometry.

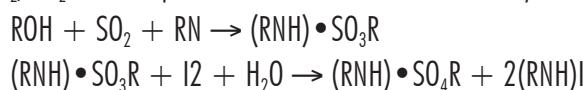

The maximum rate of the Karl Fischer reaction is reached between the pH range of 5.5 to 8 where all of the sulfur dioxide is available as methyl sulfite. If the pH drops below 5, the rate of reaction decreases and titration end point become increasingly difficult to reach. If the pH exceeds 8, side reactions begin to occur between iodine and hydroxide or methylate ions, changing the titration stoichiometry.

While solvents not containing alcohols can be used for Karl Fischer analysis, they also have an effect on reaction stoichiometry. When alcohols are not present, the reaction resembles the Bunsen reaction stoichiometry where the consumption ratio of water to iodine is 2:1. In solvents containing higher alcohols, uneven ratios can be observed due to the relative abilities of higher alcohols to form the sulfite ester that reacts with water. Issues resulting from solvent-induced variation in stoichiometry are not typically encountered during routine analysis for two reasons. First, titrant standardization and sample analysis are carried out in the same titration medium and under the same conditions, effectively compensating for any variation in reaction behavior. Second, most Karl Fischer reagent systems are formulated to support standard KF reaction stoichiometry.

### 2.2.1.2. VISUAL INDICATION OF KARL FISCHER TITRATIONS

Visual methods, originally used by Karl Fischer, are limited in application, require a high degree of skill and have been made obsolete by electrometric indication. For successful visual indication, titration samples must be colorless. Additionally, the solution coloration varies between polar and non-polar titration media.

After the titration equivalence point, all of the water in the titration solution has been reacted. The next drop of titrant, added to the solution after the equivalence point, contains iodine that will remain in the titration solution. Thereafter, the concentration of iodine in the titration solution increases and the solution develops a yellow, and eventually brown, color. It is difficult, even for an experienced analyst, to generate reproducible end point coloration between successive titrations.

### 2.2.1.3. ELECTROMETRIC INDICATION OF KARL FISCHER TITRATIONS

Biamperometric and bivolametric indication are the two types of electrometric detection methods commonly used for indication of Karl Fischer titrations. Both methods use either a double platinum pin or a double platinum ring electrode to detect excess iodine in a titration solution. After the titration equivalence point, all of the water in the titration solution has been reacted. The next dose of titrant added to the solution contains iodine, which reacts at the electrode according to the reactions below.



The excess iodine is easily reduced at the cathode, and the resulting iodide is oxidized at the anode.

Both electrometric methods of indication rely on electrons (current) being carried through a titration solution by the oxidation-reduction reactions described above. Biamperometric indication involves monitoring the flow of current through the titration solution while a constant voltage is applied across the platinum elements of the electrode. When water is present in the titration solution and there is no excess iodine, only minimal current flows between the electrode elements. After the equivalence point, when iodine is present, the current flow increases to a few  $\mu\text{A}$ .

Bivolametric indication involves measuring the voltage required to maintain a constant current flow between electrode elements. A small direct or alternating current called a polarization current ( $I_{\text{pol}}$ ) is applied between the electrode pins or rings, and the resulting voltage is measured in order to monitor the titration progress.

L-shaped titration curves are generated for both methods by plotting either the electrode current or voltage against the volume of titrant added during the titration.

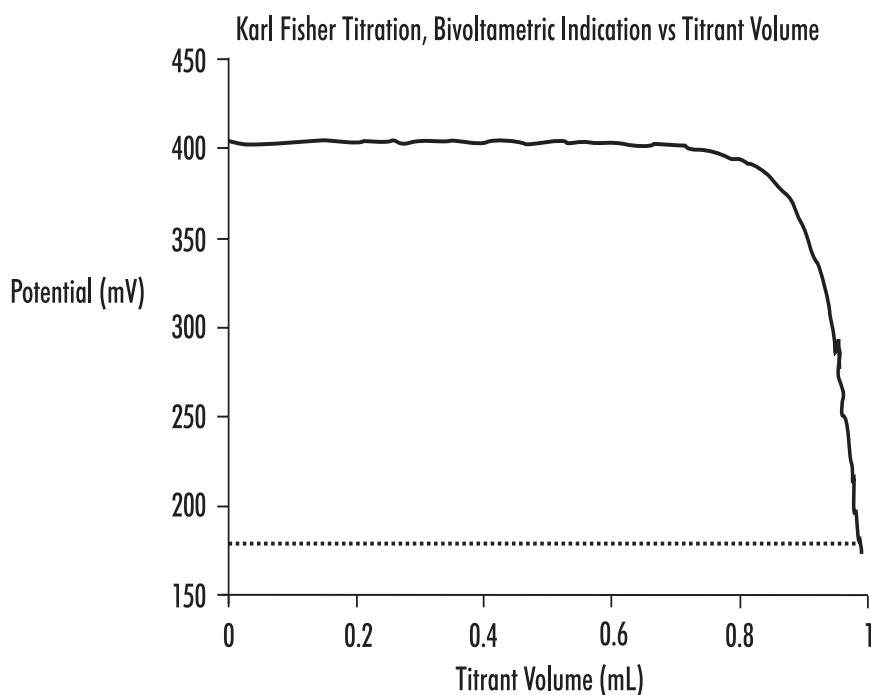

Figure 3

Electrometric methods result in over-titration or titration past the equivalence point, where excess iodine is present in the titration solution. Titration past the equivalence point is acceptable for two reasons. First, due to the sensitivity of the electrometric methods, titrations are always carried out exactly the same, slight excess of iodine resulting in highly reproducible titrations. Second, the accuracy of electrometrically indicated titrations are not affected by the over-titration because the slight excess of iodine has been accounted for during the standardization of the titrant.

### 2.2.2. ACID-BASE TITRATIONS

Acid-base titrations are the most common type of titrations. Acid-base titrations are based upon a reaction between an acid and a base, a stoichiometric neutralization, or the exchange of protons. Virtually all acid-base titrations are carried out using a strong acid or a strong base as the titrant. The end point of a titration carried out with a weak acid or a weak base, would be difficult to detect due to a small change in pH at the equivalence point.

Chemical indicators are often used to determine the end point. The indicator will change color to signify that the end of the titration has been reached. When choosing the proper indicator you should select one that has a  $pK_a$  as close to the end point of the titration as possible. The color-change region of the indicator is usually  $\pm 1$  pH unit around the  $pK_a$ . The theoretical titration curve is useful for illustrating how the solution will change during the real titration, and allowing the proper selection of an end point or an indicator.

Figure 4 shows a traditional titration curve. The curve is obtained by plotting the pH value against the volume of NaOH added.

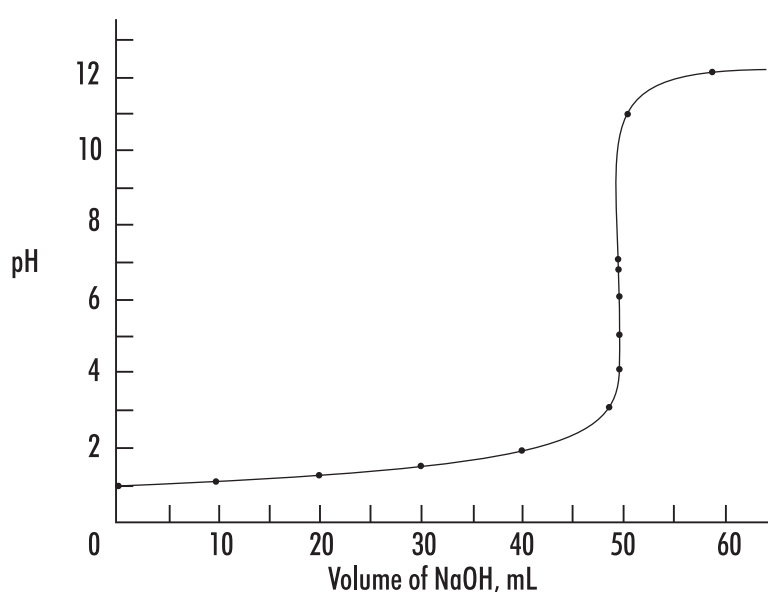

Figure 4

### 2.2.3. ARGENTOMETRIC TITRATIONS

Argentometric titrations use silver (nitrate) as the titrant and are generally precipitation titrations, as many silver salts are insoluble. These titrations are commonly used to titrate and determine the concentration of bromide, chloride, cyanide, iodide, and sulfide.

Argentometric titrations can be done with Mohr's indicator. After all of the chloride has reacted, a red silver chromate precipitate is formed or the titration can be easily followed with a silver ISE (or chloride ISE for chloride titrations) and a reference electrode.

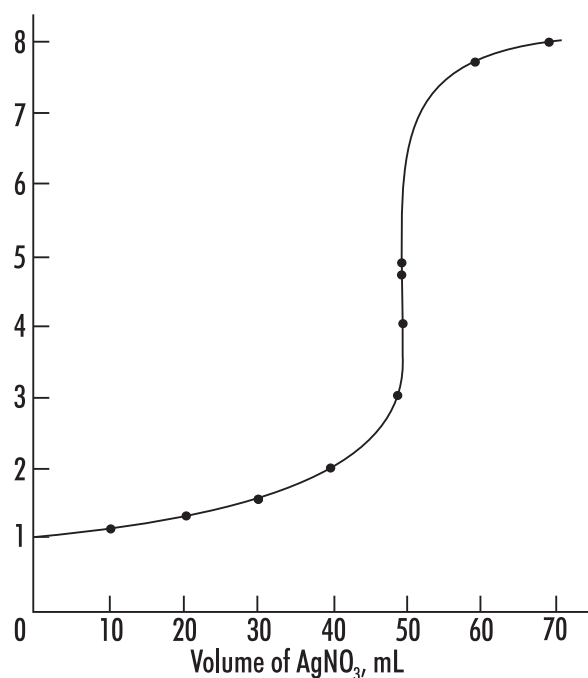

Figure 5

Figure 5 shows the titration of 50 mL of 0.1N NaCl with 0.1N AgNO<sub>3</sub>. The potentiometric signal is from a chloride ISE, and is plotted as pCl ( $-\log [Cl^-]$ ).

### 2.2.4. COMPLEXOMETRIC TITRATIONS

A complex is a species where a central metal ion is covalently bonded to one or more electron donating groups called ligands. In a complexometric titration, metal ions are titrated using a titrant that binds strongly to it. Often these titrants contain EDTA or CDTA, polydentate ligands that form very stable coordination compounds with metal ions. The complexation reaction must be fast in order to be useful for direct titration. Some metal ions react too slowly with EDTA for a direct titration.

An indicator electrode that responds to the metal ion can be used to monitor the titration progress. The titration curve will appear similar to a usual potentiometric titration. Complexation indicators change color at the end point as all metal ions are "consumed", or complexed by the titrant.

The titration curve will appear similar to a potentiometric titration, when using an indicator electrode that responds to the metal ion (see Figure 6).

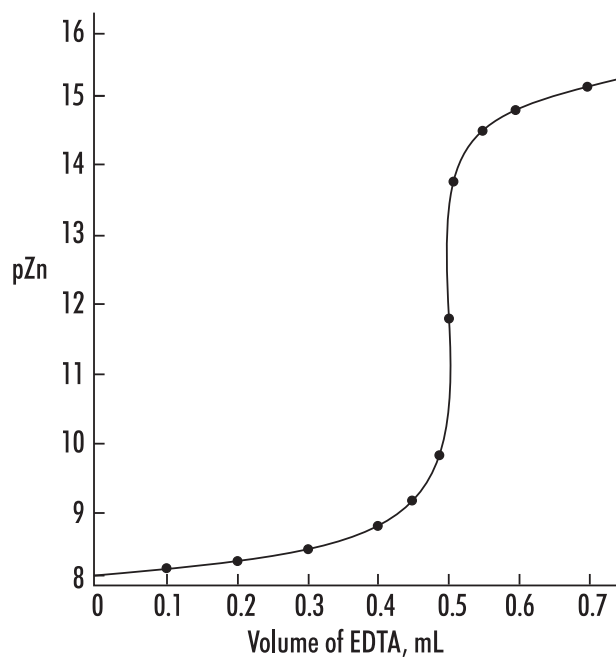

Figure 6

### 2.2.5. ION SELECTIVE TITRATIONS

The most popular ion selective titration is an acid-base titration. The hydrogen ion concentration is specifically measured and monitored during the titration process to locate the equivalence point. Using an ion selective electrode (ISE) as the indicator electrode, the potentiometric signal (in mV) is used to directly follow a specific ion's concentration (or activity). Examples of ISE titrations include titrating fluoride with an aluminum titrant using a fluoride ISE, chloride with silver nitrate using a chloride ISE, sodium with a sodium ISE, etc. The equivalence point can be determined by plotting the mV value vs. the amount of titrant added.

### 2.2.6. NON-AQUEOUS SOLVENT ACID-BASE TITRATIONS

Non-aqueous solvents must be used to titrate very weak acids and bases due to the inherent leveling effect water has on all acids and bases dissolved in it. A wide variety of weak acids and bases can be titrated using non-aqueous solvents. Mixtures of acids or bases can often be individually analyzed in a single sequential titration.

#### 2.2.6.1. TITRATION OF ACIDS

Weak acids with  $pK_a$ 's up to about 11 can be titrated in non-aqueous solvents. These include carboxylic acids, enols, phenols, imides, sulfonic acids, and inorganic acids. Water or lower alcohols are suitable for titrating medium to strong acids ( $pK_a$  less than 5). Titrating a weaker acid with a strong base titrant requires a solvent less acidic than water or ethanol/methanol. Solvents such as acetone, acetonitrile, *t*-butyl alcohol, dimethylformamide, isopropanol and pyridine have been found to work well for acid-base titrations of strong, medium and weak acids/bases. Titrants include alcoholic potassium hydroxide and various sodium or potassium alkoxides in a 10:1 mixture of benzene/methanol. The best titrants are quaternary ammonium hydroxides (such as tetrabutylammonium hydroxide) due to good solubility of tetraalkylammonium salts of the titrated acids and the clean potentiometric titration curve obtained (see Figure 7)

### 2.2.6.2. TITRATION OF BASES

Weak bases with  $pK_b$ 's up to about 11, which do not ionize with water, can be titrated in non-aqueous solvents. These bases include aliphatic and aromatic amines, basic nitrogen heterocycles, alkali metal and amine salts of acids, and many other organic basic compounds. Titrating a weak base with a strong acid titrant requires a basic solvent that is as weak as possible. Water and alcohols allow the titration of medium strength bases such as aliphatic amines ( $pK_b = 4$  to 5), but not the titration of weaker bases such as pyridine ( $pK_b = 8.8$ ). Glacial acetic acid works well for weak bases and has been used extensively. Less basic solvents such as acetone, acetonitrile, and nitromethane extend the range of titratable compounds.

The end point for non-aqueous titrations are usually determined potentiometrically using a pH glass electrode, a modified calomel or double junction reference electrode with a low-flow rate reference junction. Good potentiometric titration curves are obtained in most solvents, except those with very low dielectric constants such as benzene, chloroform and others, when high electrical resistance of the solvent causes unstable potentials.

### 2.2.7. PRECIPITATION TITRATIONS

Precipitation titrations allow for faster analysis compared to the old gravimetric analysis, where a precipitate is formed, filtered, dried and weighed to analyze a compound. Typically silver halides, silver thiocyanate and a few mercury, lead, and zinc salts are titrated using this method. The chemical reactions must form an insoluble salt and precipitate out quickly in order to be analyzed by this method. When the reaction is not quick, a back titration can be used. A measured excess of the precipitating reagent (titrant) is added to force the reaction to occur, and then unreacted titrant is titrated with a standard solution of another reagent.

### 2.2.8. REDOX TITRATIONS

There are a number of oxidation-reduction reactions that can be used to determine unknown concentration by titration. If the reaction goes to completion, is fast and has an analytical signal available to follow it, a titration can be performed. The term "fast" means that each addition of titrant is reacted completely and the sensing electrode is able to detect the change in solution in less than one second (see Figure 8).

Redox titrations are potentiometric titrations where the mV signal from a combination ORP (redox) electrode (usually with a platinum indicator electrode) is used to follow the reaction of oxidant/reductant. The electrode potential is determined by the Nernst equation and is controlled by the oxidant/reductant ratio.

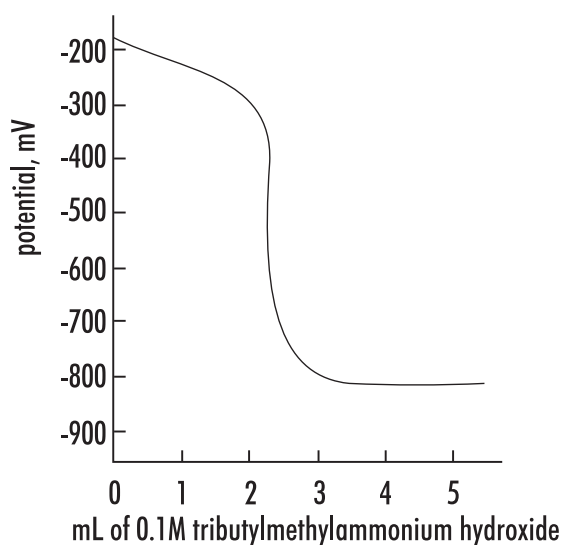

Figure 7

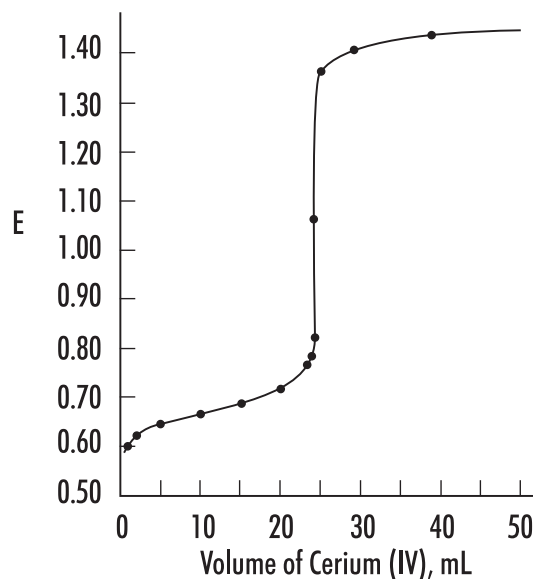

Figure 8

Visual indicators such as Ferroin are also available. The oxidized and reduced form of the indicator will have different colors and can be used to determine the end point.

Various reductants can be determined by titrants with oxidants such as potassium permanganate, potassium chromate or iodine. Commonly used reductants that are used as titrants include sodium thiosulfate and ferrous ammonium sulfate. As with Acid-Base titrations the potential changes dramatically at the equivalence point.

## 2.3. TITRATIONS ACCORDING TO THE TITRATION SEQUENCE

### 2.3.1. BACK TITRATIONS

Back titrations are generally used when a reaction is too slow to be directly accomplished during a “direct” titration, where the reaction goes to completion within a few seconds. In a back titration, a large excess of a reagent is added to the sample solution, helping a slow reaction to go to completion. The unreacted, excess reagent is then titrated. The difference in the total volume of the first reagent added and amount determined from the second titration is the quantity of reagent required to complete the first reaction.

### 2.3.2. MULTIPLE END POINT TITRATIONS

Under certain conditions, some titrations can exhibit more than one equivalence point and be titratable to the individual end points to determine the concentration of each individual component. Examples of these types of titrations include acid-base, where different strength acid or bases are in a mixture; redox, where each species has a different reduction potential; complexometric, where different species are separately titratable; and acid-base, using polyprotic acids (the  $pK_a$  of the different protons varies enough to separate them).

Figure 9 shows three different types of multiple end point titrations. Graph **A** shows the titration of a polyprotic acid. The different acid strengths of the first and second proton can be determined. Graph **B** illustrates a mixture of two different metal redox species, where the different redox potentials allow the species to be separated. Graph **C** is the titration of a solution containing strong, weak, and very weak acids.

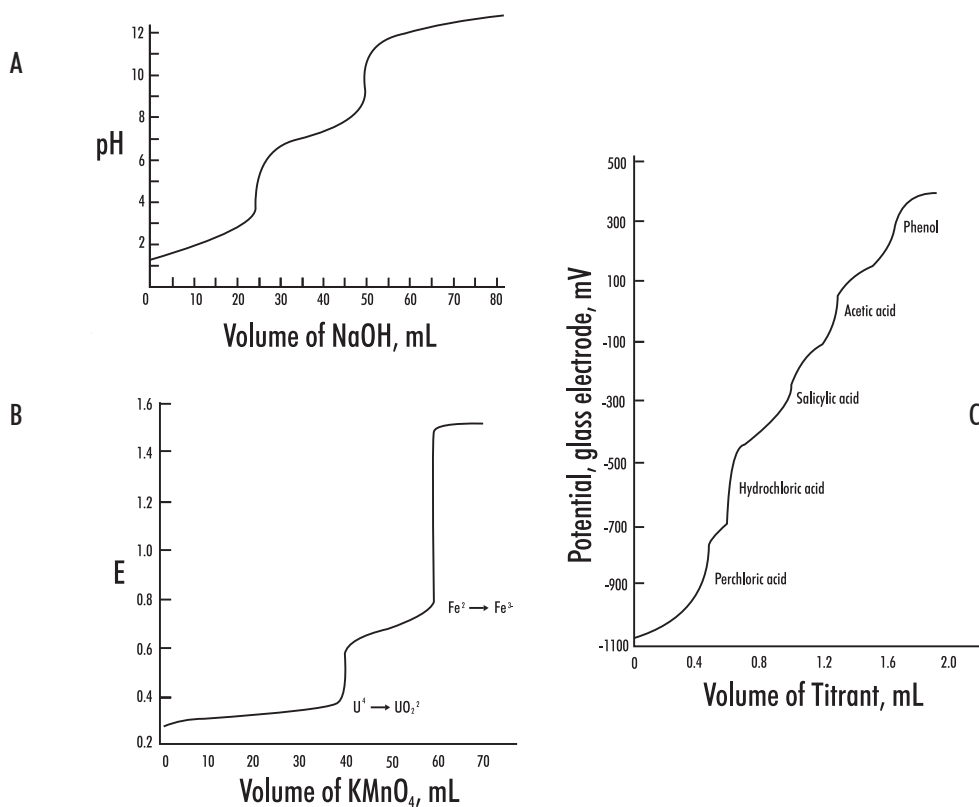

Figure 9

### 3. TITRATION PROCEDURE

#### 3.1. MANUAL TITRATION

Apparatus required for manual titration include:

- Volumetric burette, for precisely controlled delivery of titrant to the reaction vessel
- An Erlenmeyer, or similar flask, that facilitates constant mixing or swirling required to ensure solution homogeneity
- Volumetric pipettes for the precise addition of samples and indicator solutions
- Titrant solutions of known concentration
- A visual or instrumental indicator for detecting the completion of the reaction

A typical manual titration consists of the following steps:

- 1) A volumetric pipette is typically used to add a known volume of sample to the flask.
- 2) An indicator solution or instrument probe is added to the flask.
- 3) A burette is used to measure the addition of titrant to the flask and dispense titrant in a controlled manner.
- 4) Titrant is added via the burette until the method indication signals the reaction end point.
- 5) The concentration of analyte is calculated based on the concentration and volume of titrant required to reach the end point.

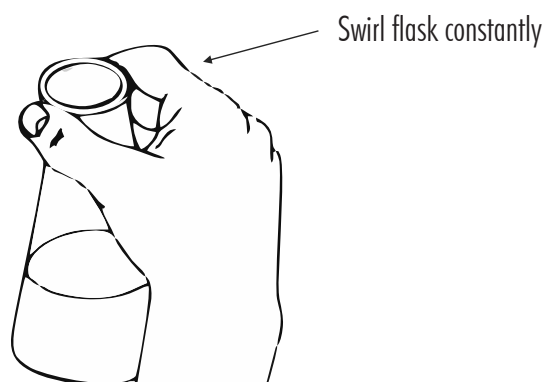
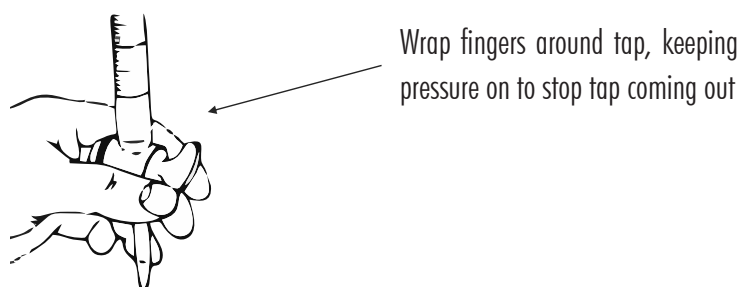

#### 3.2. AUTOMATIC TITRATION

Automatic titrators are high-precision analytical instruments that deliver the titrant, monitor the physical change associated with the titration reaction, automatically stops at the end point and calculates the concentration of the analyte. Automatic titrators are best for repetitive titrations and high-accuracy analyses.

An automatic titrator must have an accurate liquid dispensing system. In high accuracy systems like the **HI900**-series titrators, the liquid dispensing system consists of a stepper-motor driven piston syringe burette capable of accurately and precisely dispensing very small volumes of titrant, a valve system to switch between titrant intake and outlet, and a dispensing tip. These three main subsystem components must be as accurate as possible, with very low gear backlash in the burette pump, minimal piston seal flexing, precision ground inner diameter of the glass syringe, a low dead volume valve, minimal evaporation/permeation, and chemically resistant tubing.

Apparatus required for automatic titration include:

- An automatic titrator, equipped with a burette
- A beaker
- An electronic stirring system, either a propeller stirrer or a magnetic stir bar and stir plate
- Volumetric pipettes for the precise addition of samples
- Standard titrant solutions of known concentration
- An electrode system that can be used to determine the end point of the titration

A typical automatic titration consists of the following steps:

- 1) Set up the automatic titrator according to the manufacturer's instructions.
- 2) A volumetric pipette is typically used to add a known volume of sample to the beaker.
- 3) Submerge the propeller stirrer or add the stir bar to the beaker and turn on.
- 4) Start the titration, the titrator will automatically stop at the end point and determine the concentration of the analyte.

## 4. TITRATION RESULTS

### 4.1. ACCURACY

The factors most critical to achieving accurate results with the **HI900** titration systems are the concentration of the sample, size of the sample and having an optimized set of method parameters.

### 4.2. REPEATABILITY

Repeatability, or the agreement between replicate determinations, is expressed quantitatively as the relative standard deviation (RSD).

### 4.3. SOURCES OF ERROR

One of the advantages of volumetric analysis is excellent accuracy and precision. The sources of error can be grouped into sampling, titrant and standards, chemical reactions, end point determination and calculations.

#### 4.3.1. SAMPLING ERRORS

- Selection of a non-homogeneous or non-representative sample
- Sample changed or was contaminated during collection, storage or transfers
- Poor technique when transferring sample to beaker or flask
- Errors in the balance (calibrate and check balance regularly)

#### 4.3.2. PREPARATION ERRORS

Incorrect preparation due to:

- Poor technique in weighing the salt or when transferring to volumetric glassware
- Low-purity of salts or water used to make titrant and standard
- Dirty or wet glassware
- Improper storage of titrant or standard which allows water gain, evaporation or deterioration
- Failure to standardize frequently to adjust for change in titrant
- Failure to flush titrator tubing with a volume of titrant before standardizing
- Volume errors from pipettes and volumetric flasks (grade A glassware is required)
- Balance errors when weighing out salts (calibrate and check balance regularly)

#### 4.3.3. DISPENSING ERRORS

Incorrect dispensing due to:

- Dead valve volume and leaking valve
- Inaccuracy in motor drive and gear lash/backlash
- Poor burette/piston seal
- Non-uniform diameter of burette glass cylinder
- Chemical incompatibility with tubing or bubble generation
- Density/temperature changes in titrant
- Inadequate volume to cover electrode

#### 4.3.4. CHEMICAL REACTION ERRORS

- Inappropriate solvent or sample, resulting in side reactions
- Poor mixing of the titrant and solvent or sample in the titration vessel
- Reaction between titrant and sample is not rapid
- Reaction does not go to completion
- Reaction has side reactions

#### 4.3.5. END POINT DETERMINATION ERRORS

Most manual titrations use a visual indicator to indicate when the end point is reached and the titration should be stopped. Automatic titrators use instrumental methods to determine the end of a titration and the equivalence point. There are two predominant methods used to determine the equivalence point, first derivative and second derivative.

The inflection point of the titration curve (mV vs. Volume) is normally assumed to be the equivalence point. The first derivative is often used to determine the inflection point. The maximum value of the first derivative ( $\Delta mV$  vs.  $\Delta V$ ) corresponds to the theoretical equivalence point. During a titration it is rare to have a data point exactly at the first derivative maximum, the maximum value is determined by interpolating the first derivative data points.

The second derivative ( $\Delta mV^2$  vs.  $\Delta V^2$ ) can also be used to determine the equivalence point, and can offer advantages over the first derivative method. Second derivatives have increased sensitivity to smaller inflection points and easier numerical evaluation of the actual equivalence point. The value where the second derivative is equal to zero is the equivalence point. The second derivative requires fewer points located near the equivalence point, where data is often not obtained or not as reliable.

Errors in determining the end point can result from:

- Incorrect signals from the sensor
- Sensor drift
- Sensor or instrument has slow response (it is recommended to keep the sensors in good condition)
- Inappropriate setting on the titrator

## 5. CALCULATIONS

### 5.1. EQUATIONS USED IN VOLUMETRIC KARL FISCHER TITRATIONS

#### 5.1.1. CALCULATION OF WATER CONTENT AS % MASS FROM SAMPLES MEASURED BY MASS

$$C_{\text{sample}} = \frac{V_{\text{titrant}} \times \text{Titer}}{m_{\text{sample}} \times (1000 \text{ mg/g})} \times 100$$

$C_{\text{sample}}$  Concentration of Sample (% w/w)

$V_{\text{titrant}}$  Volume of Titrant (mL)

Titer Titrant Titer (mg/mL)

$m_{\text{sample}}$  Mass of sample (g)

#### 5.1.2. CALCULATION OF WATER CONTENT AS % MASS FROM SAMPLES MEASURED BY VOLUME

$$C_{\text{sample}} = \frac{V_{\text{titrant}} \times \text{Titer}}{V_{\text{sample}} \times d_{\text{sample}} \times (1000 \text{ mg/g})} \times 100$$

$C_{\text{sample}}$  Concentration of Sample (% w/w)

$V_{\text{titrant}}$  Volume of Titrant (mL)

Titer Titrant Titer (mg/mL)

$V_{\text{sample}}$  Volume of Sample (mL)

$d_{\text{sample}}$  Density of Sample (g/mL)

#### 5.1.3. CALCULATION OF WATER CONTENT AS % VOLUME FROM SAMPLES MEASURED BY VOLUME

$$C_{\text{sample}} = \frac{V_{\text{titrant}} \times \text{Titer}}{V_{\text{sample}} \times d_{\text{water}} \times (1000 \text{ mg/g})} \times 100$$

$C_{\text{sample}}$  Concentration of Sample (% w/w)

$V_{\text{titrant}}$  Volume of Titrant (mL)

Titer Titrant Titer (mg/mL)

$V_{\text{sample}}$  Volume of Sample (mL)

$d_{\text{water}}$  Density of Water at Analysis Temperature (g/mL)

#### 5.1.4. CALCULATION OF WATER CONTENT AS % MASS SUBTRACTING BACKGROUND DRIFT RATE

$$C_{\text{sample}} = \frac{(V_{\text{titrant}} \times \text{Titer}) - [\text{Drift} \times t \times (1 \text{ mg}/1000 \text{ } \mu\text{g})]}{m_{\text{sample}} \times (1000 \text{ mg/g})} \times 100$$

$C_{\text{sample}}$  Concentration of Sample (% w/w)

$V_{\text{titrant}}$  Volume of Titrant (mL)

Titer Titrant Titer (mg/mL)

Drift Background Drift Rate ( $\mu\text{g}/\text{min}$ )

t Titration Duration (min)

$m_{\text{sample}}$  Mass of Sample (g)

### 5.1.5. CALCULATION OF WATER CONTENT IN EXTERNAL DISSOLUTION SAMPLES

$$C_{\text{sample}} = \left[ \frac{m_{\text{solvent}} \times (C_{\text{solution}} - C_{\text{solvent}})}{m_{\text{sample}}} + C_{\text{solution}} \right] \times 100$$

$C_{\text{sample}}$	Concentration of Sample (% w/w)
$m_{\text{solvent}}$	Mass of Solvent (g)
$C_{\text{solution}}$	Water Content of Dissolved Sample (w/w)
$C_{\text{solvent}}$	Water Content of Solvent (w/w)
$m_{\text{sample}}$	Mass of Sample (g)

### 5.1.6. CALCULATION OF WATER CONTENT IN EXTERNAL EXTRACTION SAMPLES

$$C_{\text{sample}} = \frac{m_{\text{titrant}} \times (C_{\text{supernatant}} - C_{\text{solvent}})}{m_{\text{solvent}} \times (1 - C_{\text{supernatant}})} \times 100$$

$C_{\text{sample}}$	Concentration of Sample (% w/w)
$m_{\text{solvent}}$	Mass of Solvent (g)
$C_{\text{supernatant}}$	Water Content of Dissolved Sample (w/w)
$C_{\text{solvent}}$	Water Content of Solvent (w/w)
$m_{\text{sample}}$	Mass of Sample (g)

### 5.1.7. CALCULATION OF WATER CONTENT IN GASEOUS SAMPLES

The water content of gases is normally reported in units of  $\mu\text{g/L}$  or  $\text{mg/L}$ .

$$C_{\text{sample}} = \frac{V_{\text{titrant}} \times \text{Titer}}{\text{Flow Rate} \times \text{Flow Duration}}$$

$C_{\text{sample}}$	Concentration of Sample (mg/mL)
$V_{\text{titrant}}$	Volume of Titrant (mL)
Titer	Titrant Titer (mg/mL)
Flow Rate	Sample Flow Rate (L/min)
Flow Duration	Sample Extraction Time (min)

To calculate the water content in %w/w the mass of the gas introduced into the titration vessel must be known. This can be determined by calculations using ideal gas laws or by measuring the mass of the sample container before and after a titration.

### 5.1.8. CALCULATION OF TITER (WATER EQUIVALENT OF THE TITRANT) USING SODIUM TARTRATE DIHYDRATE CONTAINING 15.66% WATER BY MASS

$$C_{\text{titrant}} = \frac{m_{\text{sample}} \times C_{\text{tartrate}}}{V_{\text{titrant}}}$$

$C_{\text{titrant}}$	Titrant Titer (mg/mL)
$m_{\text{sample}}$	Mass of Sample (g)
$C_{\text{tartrate}}$	Water Content of Tartrate (156.6 mg/g)
$V_{\text{titrant}}$	Volume of Titrant (mL)

### 5.1.9. CALCULATION OF TITER (WATER EQUIVALENT OF THE TITRANT) USING WATER STANDARDS

$$C_{\text{titrant}} = \frac{m_{\text{sample}} \times C_{\text{standard}}}{V_{\text{titrant}}}$$

$C_{\text{titrant}}$	Titration Titer (mg/mL)
$m_{\text{sample}}$	Mass of Sample (g)
$C_{\text{standard}}$	Water Content of Standard (mg/g)
$V_{\text{titrant}}$	Volume of Titrant (mL)

### 5.2. EQUATIONS USED IN TITRATIONS

The main variables used in calculating a result from a titration are the sample volume, the concentration of the titrant, and the volume of titrant required to reach the equivalence point. At the equivalence point, an equal number of equivalents of the analyte and titrant has been added.

#### 5.2.1. SAMPLE CALCULATION BY MASS

$$C_{\text{sample}} = \frac{V_{\text{titrant}} \times C_{\text{titrant}} \times \text{Ratio} \times \text{FW}_{\text{analyte}}}{m_{\text{sample}}} \times 100$$

$C_{\text{sample}}$	Sample Concentration (g/100g)
$V_{\text{titrant}}$	Volume of titrant
$C_{\text{titrant}}$	Titration Concentration (eq/L)
Ratio	Equivalence ratio of analyte/ titrant (mol analyte/ eq titrant)
$\text{FW}_{\text{analyte}}$	Formula Weight of the Analyte (g/mol)
$m_{\text{sample}}$	Mass of sample (g)

#### 5.2.2. SAMPLE CALCULATION BY VOLUME

$$C_{\text{sample}} = \frac{V_{\text{titrant}} \times C_{\text{titrant}} \times \text{Ratio} \times \text{FW}_{\text{analyte}}}{V_{\text{sample}}} \times 100$$

$C_{\text{sample}}$	Sample Concentration (g/100g)
$V_{\text{titrant}}$	Volume of titrant
$C_{\text{titrant}}$	Titration Concentration (eq/L)
Ratio	Equivalence ratio of analyte/ titrant (mol analyte/ eq titrant)
$\text{FW}_{\text{analyte}}$	Formula Weight of the Analyte (g/mol)
$V_{\text{sample}}$	Volume of Sample (mL)

### 5.2.3. STANDARDIZE TITRANT BY MASS

Titrant standardization is the second most important calculation in titrations. A primary standard is titrated in order to determine the concentration of the titrant. This is essentially a typical titration calculated in “reverse”, where the concentration of the solution is known and the titrant is unknown.

$$C_{\text{titrant}} = \frac{m_{\text{standard}} \times \text{Ratio}}{\text{FW}_{\text{standard}} \times V_{\text{titrant}}}$$

$C_{\text{titrant}}$	Titrant Concentration (N)
$m_{\text{standard}}$	Mass of Standard (g)
Ratio	Equivalence ratio of titrant/standard (eq titrant/ mol standard)
$\text{FW}_{\text{standard}}$	Formula Weight of the Standard (g/mol)
$V_{\text{titrant}}$	Volume of Titrant (L)

### 5.2.4. STANDARDIZE TITRANT BY VOLUME

$$C_{\text{titrant}} = \frac{V_{\text{standard}} \times (1 \text{ L}/1000 \text{ mL}) \times C_{\text{standard}}}{V_{\text{titrant}}}$$

$C_{\text{titrant}}$	Titrant Concentration (N)
$V_{\text{standard}}$	Volume of Standard (mL)
$C_{\text{standard}}$	Concentration of Standard (eq/L)
$V_{\text{titrant}}$	Volume of Titrant (L)

### 5.2.5. BLANK TITRATION

In a blank titration a pre-titration is performed, often times on the solvent to be used for the sample titration, and the titrant volume required to reach the end point is noted. This blank value nullifies error due to titrant required to react with the components of the titration solution matrix. The basic titration equation can be used for a blank titration, with the single modification that the volume of titrant used in the blank titration should be subtracted from the regular titration titrant volume.

$$C_{\text{sample}} = \frac{C_{\text{titrant}} \times (V_{\text{sample}} - V_{\text{blank}}) \times \text{Ratio} \times \text{FW}_{\text{analyte}}}{m_{\text{sample}}} \times 100$$

$C_{\text{sample}}$	Sample Concentration (g/100 g)
$C_{\text{titrant}}$	Titrant Concentration (eq/L)
$V_{\text{sample}}$	Volume of Titrant required for the sample (L)
$V_{\text{blank}}$	Volume of Titrant required for the blank (L)
Ratio	Equivalence ratio of analyte/ titrant (mol analyte/ eq titrant)
$\text{FW}_{\text{analyte}}$	Formula Weight of the Analyte (g/mol)
$m_{\text{sample}}$	Mass of sample (g)

### 5.2.6. MULTIPLE END POINT TITRATION

Some titrations have two or more end points, each corresponding to the equivalence point for a specific reaction. Multiple end point titrations are similar to a blank titration in that the volume of titrant required to reach the first end point is subtracted from the titrant volume used to reach the next sequential end point.

$$C_{\text{sample1}} = \frac{V_{\text{titrant1}} \times C_{\text{titrant}} \times \text{Ratio} \times \text{FW}_{\text{analyte1}}}{m_{\text{sample}}} \times 100$$

$$C_{\text{sample2}} = \frac{(V_{\text{titrant2}} - V_{\text{titrant1}}) \times C_{\text{titrant}} \times \text{Ratio} \times \text{FW}_{\text{analyte2}}}{m_{\text{sample}}} \times 100$$

$$C_{\text{sample3}} = \frac{(V_{\text{titrant3}} - V_{\text{titrant2}}) \times C_{\text{titrant}} \times \text{Ratio} \times \text{FW}_{\text{analyte3}}}{m_{\text{sample}}} \times 100$$

$C_{\text{sample1}}$	Sample 1 Concentration (g/100g)
$C_{\text{sample2}}$	Sample 2 Concentration (g/100g)
$C_{\text{sample3}}$	Sample 3 Concentration (g/100g)
$V_{\text{titrant1}}$	Volume of titrant required to reach the first end point (L)
$V_{\text{titrant2}}$	Volume of titrant required to reach the second end point (L)
$V_{\text{titrant3}}$	Volume of titrant required to reach the third end point (L)
$C_{\text{titrant}}$	Concentration of titrant (N)
Ratio	Equivalence ratio of analyte/titrant (mol analyte/eq titrant)
$\text{FW}_{\text{analyte1}}$	Formula Weight of the Analyte 1 (g/mol)
$\text{FW}_{\text{analyte2}}$	Formula Weight of the Analyte 2 (g/mol)
$\text{FW}_{\text{analyte3}}$	Formula Weight of the Analyte 3 (g/mol)
$m_{\text{sample}}$	Mass of Sample (g)

### 5.2.7. BACK TITRATION

The equation used in back titration calculations is also similar to the equation for a blank titration. Instead of subtracting the initial amount of titrant needed to react with the blank, the amount of second titrant needed to react with the excess titrant added in the first titration is subtracted from the amount of the first titrant added. The difference between the two amounts is the amount of titrant necessary to reach the first equivalence point.

$$C_{\text{sample}} = \frac{(C_{\text{titrant1}} \times V_{\text{titrant1}} - C_{\text{titrant2}} \times V_{\text{titrant2}}) \times \text{Ratio} \times \text{FW}_{\text{analyte}}}{V_{\text{sample}}} \times 100$$

$C_{\text{sample}}$	Sample Concentration (g/100mL)
$C_{\text{titrant1}}$	Concentration of titrant 1 (N)
$V_{\text{titrant1}}$	Volume of titrant 1 (L)
$C_{\text{titrant2}}$	Concentration of titrant 2 (N)
$V_{\text{titrant2}}$	Volume of titrant 2 (L)
Ratio	Equivalence ratio of analyte/titrant (mol analyte/ eq titrant)
$\text{FW}_{\text{analyte}}$	Formula Weight of the analyte (g/mol)
$V_{\text{sample}}$	Volume of sample (mL)

## 6. GLOSSARY

### Acid

A chemical species that can donate one or more protons (hydrogen ions).

### Acid-Base Titration

Stoichiometric neutralization titrations, based upon the reaction that occurs between an acid and base.

### Activity

A physical property corresponding to the concentration of all ions in a solution. Electrodes respond to activity.

### Amperometric Titration

Titrations where the current flow between two electrodes (often a metal electrode and a reference electrode) are used to monitor the titration progress.

### Analyte

The chemical species being measured in a titration.

### Argentometric Titration

Titrations that use silver (nitrate) as the titrant. These titrations are typically precipitation titrations.

### Automatic Titrator

An instrument designed to automatically carry out a titration. It will add the appropriate amount of titrant, determine the end-point and calculate the results.

### Back Titration

A type of titration where an excess amount of titrant is added to a sample forcing a sluggish reaction to go to completion. The excess reagent is then "back" titrated with a second titrant.

### Base

A chemical species that can accept one or more protons (hydrogen ions).

### Biamperometric Indication

Uses a double platinum pin electrode to measure the current flow through a titration solution.

### Bivoltametric Indication

Uses a double platinum pin electrode to measure the voltage required to maintain a constant current flow through a titration solution while constant voltage is applied across the platinum elements of the electrode.

### Burette

A graduated cylindrical piece of laboratory glassware that is used to dispense precise amounts of solution.

### Complex Ion

A species where a central metal ion is covalently bonded to one or more electron donating groups called ligands.

### Complexometric Titrations

Metal ions are titrated using a titrant that binds strongly to it. The titrants often contain Ethylenediaminetetraacetic Acid (EDTA) or Cyclohexylenedinitrilotetraacetic Acid (CDTA).

### End point

The point where a titration is stopped because a physical change in the solution has indicated a completed titration. Titration end points typically coincide with the equivalence point. A fixed value end point (pH or mV) can be used as well. The titration will stop at the desired point regardless of whether the titration is complete.

**Equivalence point**

The point where the quantity of titrant is stoichiometrically equal to the quantity of analyte.

**Formal**

The theoretical number of equivalents per liter of the solution. It is used in solutions where the exact concentration of a species may be affected by the other ions present, therefore the stated concentration may not be exactly correct.

**Gravimetric Analysis**

A quantitative determination of an analyte based on the mass of the solid.

**Indicator Electrode**

An electrode that responds to the species of interest. The electrode potential is proportional to the concentration or activity of that ion in the solution being measured.

**Indicators**

Chemical indicators are typically organic dyes that change form under different physical conditions, causing a color change that can be seen by an analyst. Typically used in manual titrations. Chemical indicators have been replaced with electrometric indicators, which are used with automatic titrators.

**Inflection Point**

The point on a titration curve where the second derivative curve changes signs.

**Ion Selective Electrode (ISE)**

An electrode that responds to a specific ion, the electrode potential is proportional to the concentration or activity of that ion in the solution being measured.

**Karl Fischer Titration**

A titration that uses a chemical reaction that is specific for determining water.

**Manual Titration**

A titration that is carried out by hand, the analyst must add the appropriate amount of titrant, determine the end point and calculate the results.

**Molar**

The concentration of a solute in a solution.

**Mole (mol)**

A quantity of a chemical species. The molecular weight of a substance in grams is equal to the mass of one mole of the substance. One mole is equal to  $6.022 \times 10^{23}$  atoms or molecules.

**Monochromator**

A device that allows only a narrow range of wavelengths to pass through it by separating the light into different wavelengths.

**Multiple End Point Titration**

A titration that reacts multiple species in solution, sequentially using the same titrant. The concentration of each analyte can be determined from their respective end points.

**Nernst Equation**

The fundamental equation relating cell voltage to the concentration of a solution.

**Neutralization**

A chemical reaction where an acid and a base react to form a neutral salt and water.

**Non-aqueous**

A solution that does not contain water.

**Non-aqueous Titration**

A titration that is performed in non-aqueous solutions. Typically used to titrate very weak acid and bases to eliminate the leveling effect water has on all acids and bases dissolved in it.

**Normal**

The concentration of a solution which accounts for any stoichiometric difference between the various species in a solution.

**Oxidation/ Reduction Potential (ORP)**

A voltage generated in a solution which is a result of the ratio of the oxidized to reduce species. Typically measured potentiometrically with an ORP sensor.

**Oxidant**

The species that is accepting electrons in a redox reaction.

**Pipette**

Scientific apparatus that is used to deliver precise volumes of liquids.

**Polyprotic Acid**

Acids that are capable of donating more than one proton per acid molecule.

**Potentiometric Titration**

A titration in which the end point is determined by monitoring the voltage of the solution using an electrode.

**Precipitation Titration**

A titration in which the analyte reacts with the titrant to form an insoluble compound. The end point is typically detected with an ISE sensitive to either the analyte or titrant.

**Reagent**

The chemical added in a titration that causes the given reaction to occur.

**Reduction-Oxidation Reaction (redox)**

A chemical reaction in which the atoms involved in the reaction have their oxidation numbers changed. Reduction is the gain of electrons, which decreases the oxidation number. Oxidation is the loss of electrons, which increases the oxidation number.

**Reductants**

The electron donor in a redox reaction.

**Reference Electrode**

An electrode that supplies a constant electrode potential. It is used in combination with an "indicator" electrode, allowing for the "indicator" electrode potential to be measured.

**Relative Standard Deviation (RSD)**

A measure of the amount of relative variation in a set of data. It is calculated by dividing the standard deviation by the mean:

$$\text{RSD} = (\text{Standard Deviation of } X) * 100 / (\text{Mean of } X)$$

**Repeatability**

The variation in sample measurements taken by a single person or instrument under the same conditions.

**Spectrophotometric Titration**

A titration in which the end point is marked by a change in the color and/or color intensity.

**Stoichiometry**

The quantitative relationship of the reactants and products in a chemical reaction.

**Titrant**

The chemical added in a titration that causes the given reaction to occur.

**Titration**

A quantitative, volumetric procedure used in analytical chemistry to determine the concentration of an analyte in solution. The concentration of the analyte is determined by slowly adding a titrant to the solution. As the titrant is added, a chemical reaction between the titrant and the analyte occurs.

**Titration Curve**

A graph containing the physical data obtained for a titration. The data plotted is often an independent variable (volume of titrant) vs. a dependent variable (pH of the solution). From the titration curve, the equivalence point or end point can be determined.

## Certification

All Hanna Instruments conform to the **CE European Directives**.



RoHS  
compliant

**Disposal of Electrical & Electronic Equipment.** The product should not be treated as household waste. Instead hand it over to the appropriate collection point for the recycling of electrical and electronic equipment which will conserve natural resources.

Ensuring proper product and battery disposal prevents potential negative consequences for the environment and human health. For more information, contact your city, your local household waste disposal service, the place of purchase or go to [www.hannainst.com](http://www.hannainst.com).



## Recommendations for Users

Before using this product, make sure it is entirely suitable for your specific application and for the environment in which it is used. Any variation introduced by the user to the supplied equipment may degrade the meters' performance. For yours and the meter's safety do not use or store the meter in hazardous environments.

## Warranty

The **HI933** is warranted for two years against defects in workmanship and materials when used for its intended purpose and maintained according to instructions. Damage due to accidents, misuse, tampering or lack of prescribed maintenance is not covered.

If service is required, contact your local Hanna Instruments Office. If under warranty, report the model number, date of purchase, serial number and the nature of the problem. If the repair is not covered by the warranty, you will be notified of the charges incurred. If the instrument is to be returned to Hanna Instruments, first obtain a Returned Goods Authorization (RGA) number from the Technical Service department and then send it with shipping costs prepaid. When shipping any instrument, make sure it is properly packed for complete protection.

Hanna Instruments reserves the right to modify the design, construction or appearance of its products without advance notice.

## World Headquarters

Hanna Instruments Inc.  
Highland Industrial Park  
584 Park East Drive  
Woonsocket, RI 02895 USA  
[www.hannainst.com](http://www.hannainst.com)