



CMA™
Cemented Modular Augmentable
Baseplate

U2 Knee

More can be addressed...

The **U2 Cemented Modular Augmentable Baseplate** is an optimal solution for tibial bone defect in primary total knee replacement. Indications such as **Unilateral Moderate Tibial Bone Deficiencies** can now be well addressed following simple instruments.

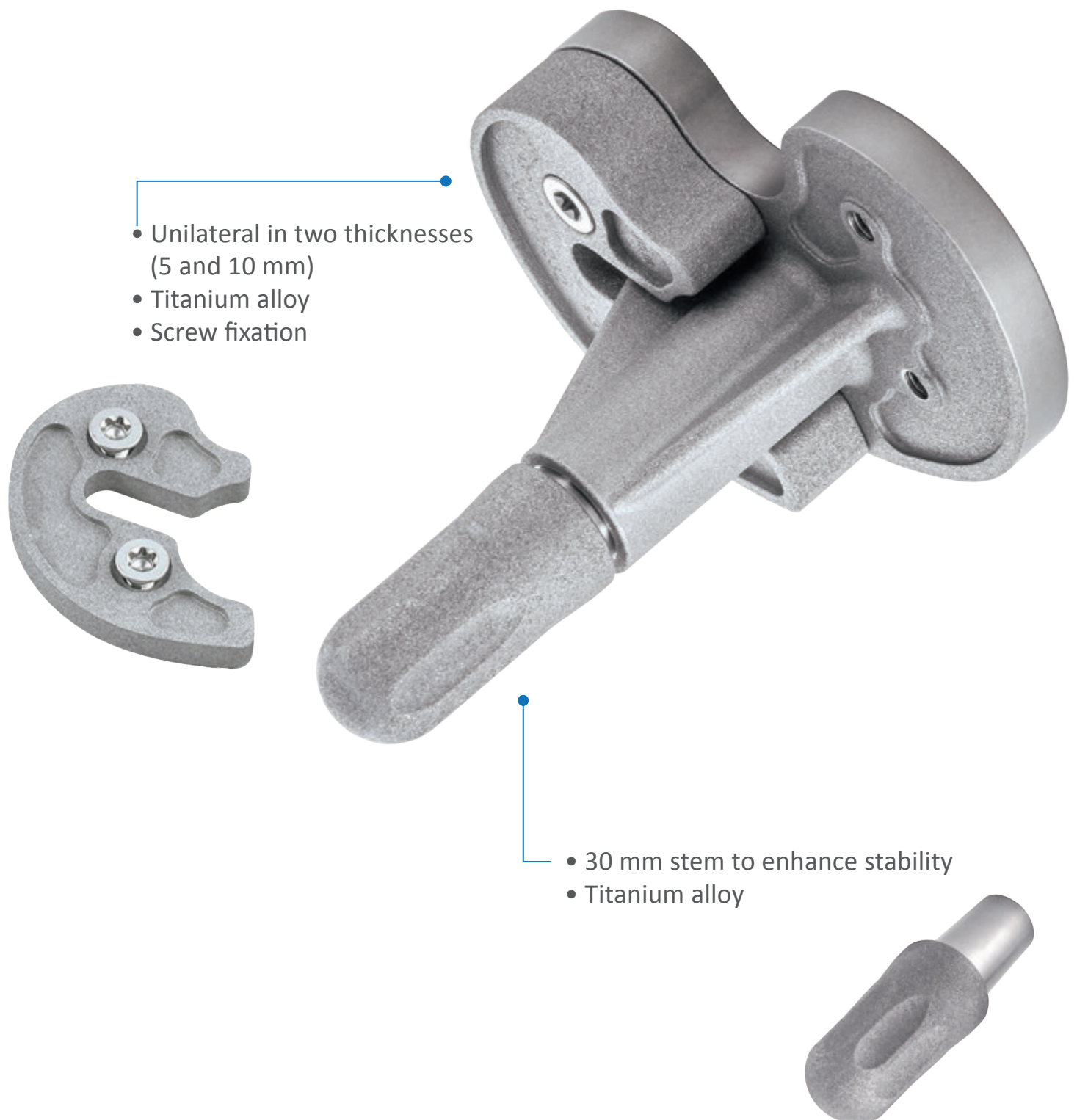

Each Step We Care

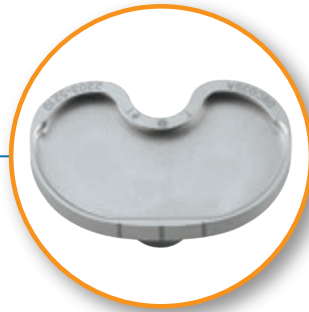

Without through hole design avoids potential backside wear

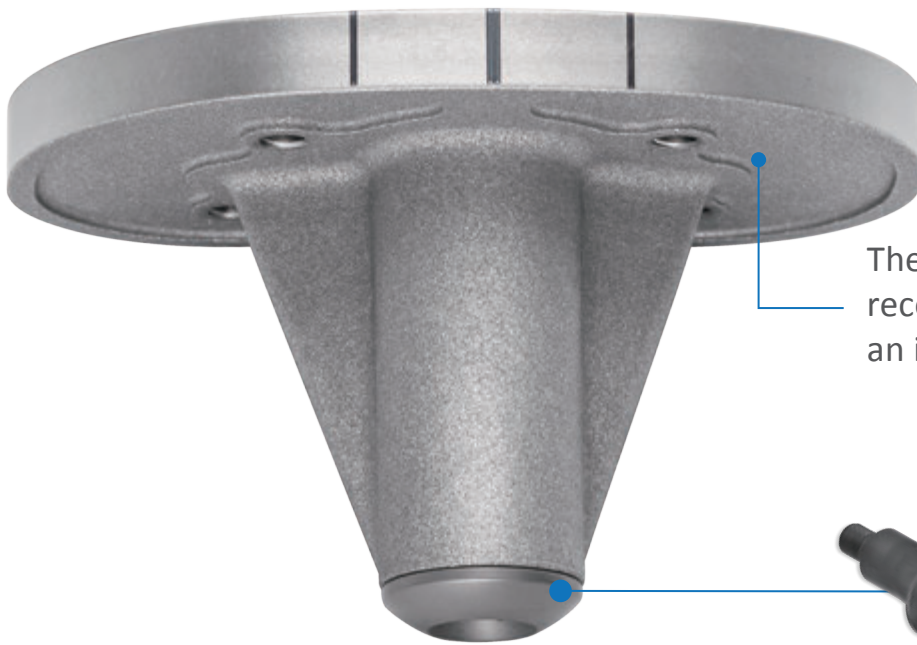

The roughen texture of the recessed undersurfaces ensure an ideal cement fixation



Distal end sealed with pre-assembled plug

Tibial Baseplate, CMA

Number	AP	ML
★2203-3200	#0	39.5 60
2203-3210	#1	42 63
2203-3220	#2	44.5 66
2203-3230	#3	47 69
2203-3240	#4	49.5 72
2203-3250	#5	52.5 76
2203-3260	#6	55.5 80
★2203-3270	#7	58.5 84

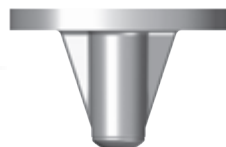
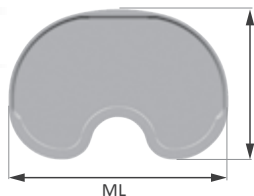

★ *Special Order Items*

Accessories

Tibial Augment



Number	Description	Number	Description
★2803-5201	#0 5 mm	★2803-5202	#0 10 mm
2803-5211	#1 5 mm	2803-5212	#1 10 mm
2803-5221	#2 5 mm	2803-5222	#2 10 mm
2803-5231	#3 5 mm	2803-5232	#3 10 mm
2803-5241	#4 5 mm	2803-5242	#4 10 mm
2803-5251	#5 5 mm	2803-5252	#5 10 mm
2803-5261	#6 5 mm	2803-5262	#6 10 mm
★2803-5271	#7 5 mm	★2803-5272	#7 10 mm

Straight Stem

Number	Description
2703-5003	Ø14 x 30 mm



Surgical Procedure

Using the Tibial Augment / Straight Stem with U2 CMA Baseplate

Prepare the initial trial reduction as indicated in "Initial Tibial Baseplate Trial Insertion" --U2 Knee Surgical Protocol, Step C.2. Then continue with the following steps:

A. Tibial Augment Resection

Align the **Tibial Baseplate Trial** with resected tibia surface and secure the baseplate trial to the proximal tibia with **2 Head Pins** according to the rotational orientation. Use the **CMA 3.2 mm Drill** to drill carefully through the center tunnel below the **Tibial Baseplate Trial**. Stop drilling when reaching to the marked depth according to desired size of tibial baseplate. A center groove on the proximal tibia plane is formed as a vertical resection reference.

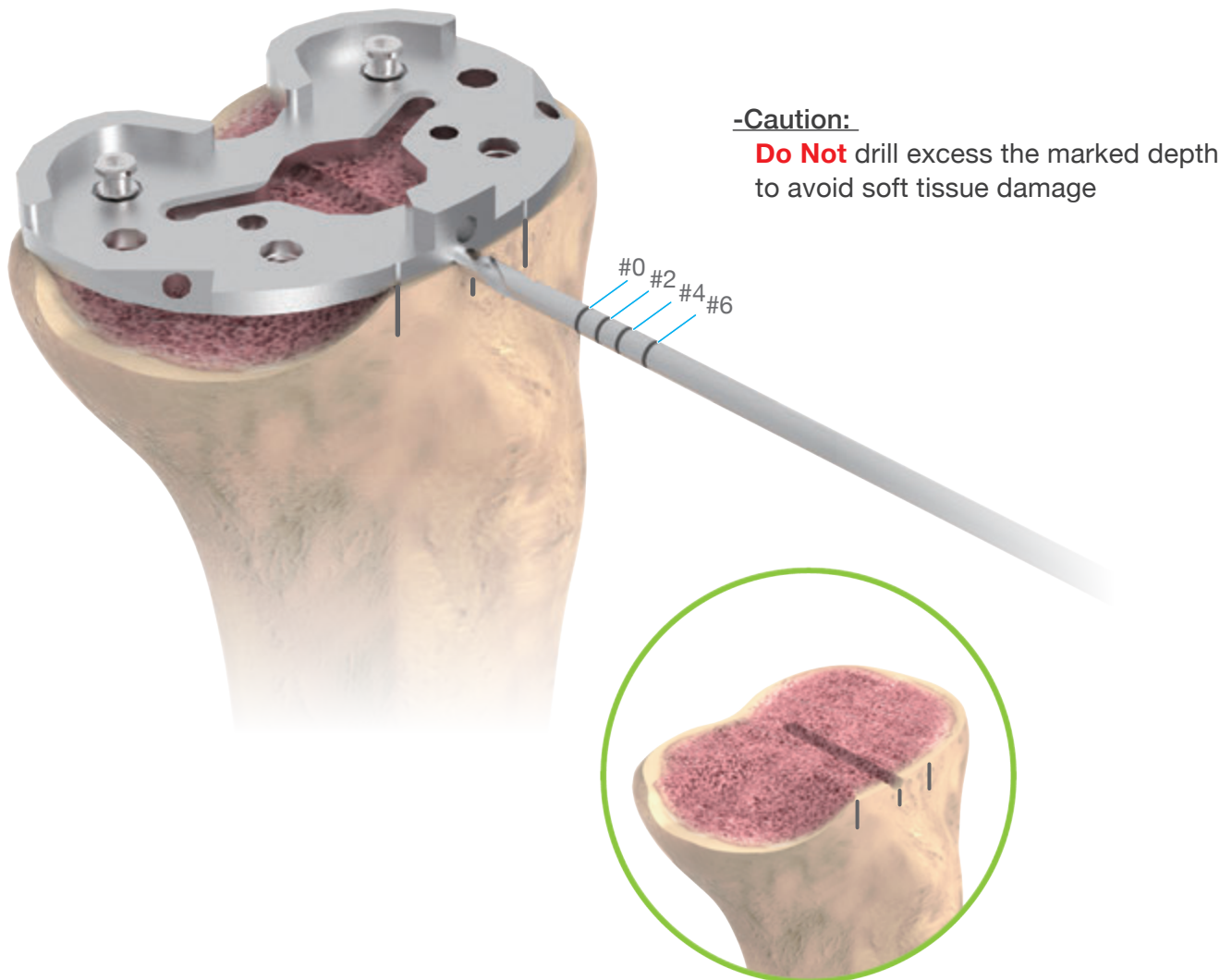

Assemble the appropriate **Tibial Augment Resection Guide** (left or right) and the **Tibial Augment Resection Guide Adaptor** onto the **Tibial Baseplate Trial**.

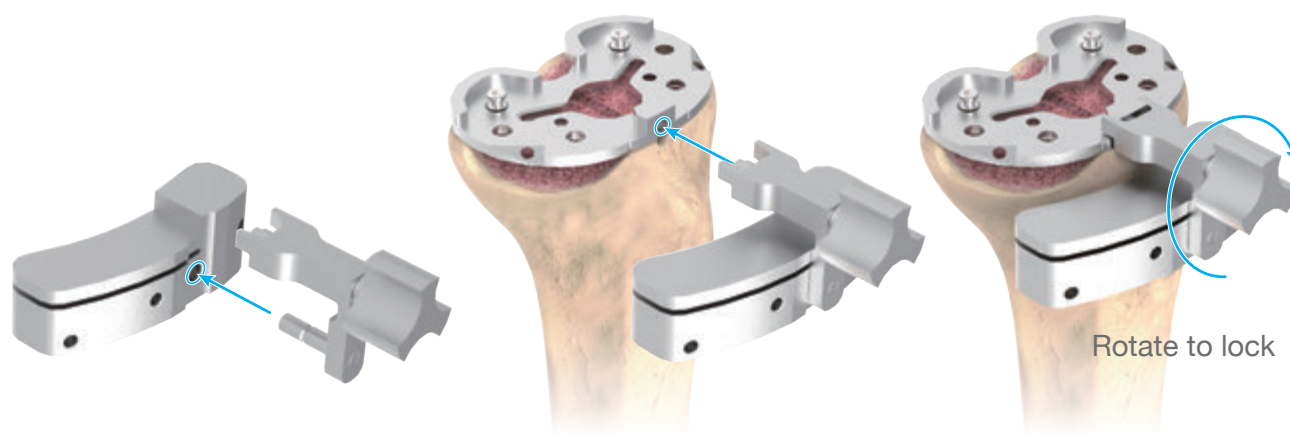

Apply threaded pins to secure the **Tibial Augment Resection Guide** to the tibia. Then, remove the **Tibial Augment Resection Guide Adaptor** and the **Tibial Baseplate Trial**.

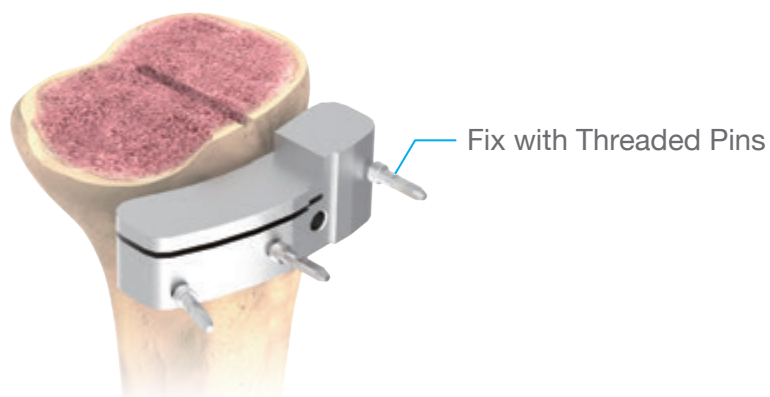

Perform the horizontal resection by referencing the upper plane for 5 mm augment or the slot for 10 mm augment. Finish the vertical resection referring to the center groove on the top of proximal tibial plane.

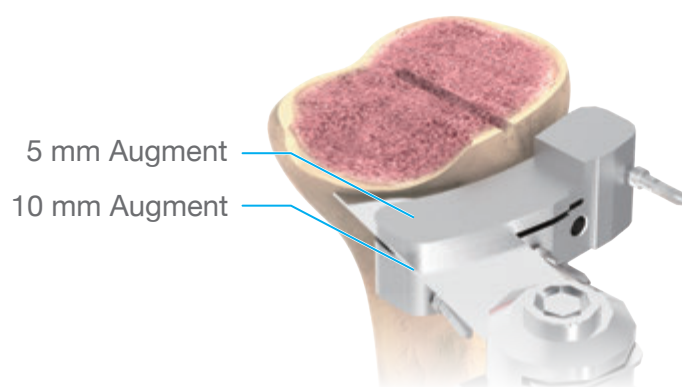

Each Step We Care

B. Tibial Fin Slot Preparation

Assemble the desired **Tibial Augment Trial** to the backside of the **CMA Tibial Baseplate Trial** and fix the trial combination onto the resected tibial surface with two head pins. Then, attach the **CMA Tibial Drill Guide**, to the baseplate trial.

To ensure the stability of tibial component, an 30 mm distal stem is recommended. Advance the **Straight Stem Drill** through the **Tibial Drill Guide** until the depth reaches the laser mark of the "0-4" or "5-7" line according to the selected size of the **CMA Tibial Baseplate Trial**. The drill and drill guide are then removed.

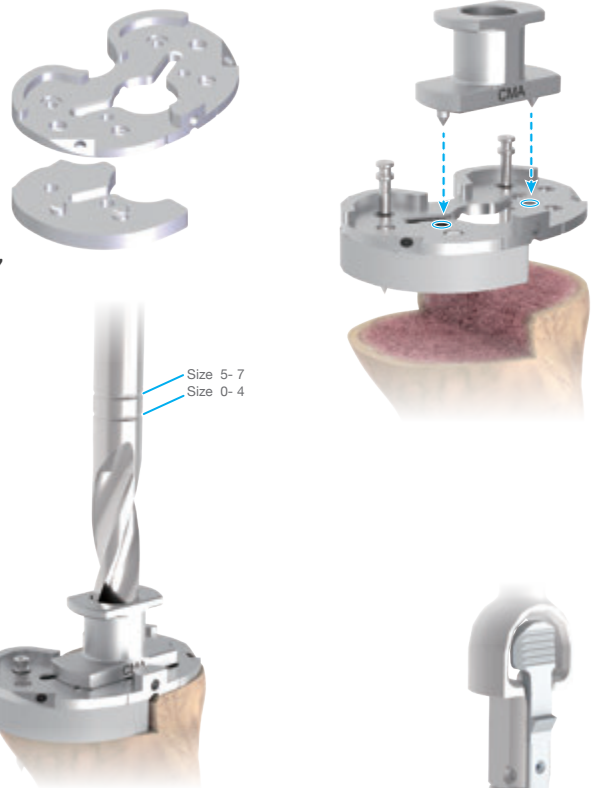

Continue with tibial punching to finish the fin slot preparation.
(Referring to U2 Knee Surgical Protocol, Step C.3.)



C. Implant Assembling

After final trial reduction, assemble the **Screw Driver Adaptor** to the **Driver Handle**, then fasten the determined augment onto the baseplate.

If the straight stem is required, unscrew the plug at the bottom of the baseplate via **Screw Driver**.



Insert the trunnion of the stem into the implant taper. Solidly tap the stem onto the baseplate with the **Stem Impactor** to make sure the stem is firmly set.



Trials



Number	Description
★ 2203-4000-RB #0	Baseplate Trial, CMA
2203-4010-RB #1	Baseplate Trial, CMA
2203-4020-RB #2	Baseplate Trial, CMA
2203-4030-RB #3	Baseplate Trial, CMA
2203-4040-RB #4	Baseplate Trial, CMA
2203-4050-RB #5	Baseplate Trial, CMA
2203-4060-RB #6	Baseplate Trial, CMA
★ 2203-4070-RB #7	Baseplate Trial, CMA



Number	Description	Number	Description
★ 2803-6101	Left #0 5mm Augment Trial	★ 2803-6201	Right #0 5mm Augment Trial
2803-6111	Left #1 5mm Augment Trial	2803-6211	Right #1 5mm Augment Trial
2803-6121	Left #2 5mm Augment Trial	2803-6221	Right #2 5mm Augment Trial
2803-6131	Left #3 5mm Augment Trial	2803-6231	Right #3 5mm Augment Trial
2803-6141	Left #4 5mm Augment Trial	2803-6241	Right #4 5mm Augment Trial
2803-6151	Left #5 5mm Augment Trial	2803-6251	Right #5 5mm Augment Trial
2803-6161	Left #6 5mm Augment Trial	2803-6261	Right #6 5mm Augment Trial
★ 2803-6171	Left #7 5mm Augment Trial	★ 2803-6271	Right #7 5mm Augment Trial
★ 2803-6102	Left #0 10mm Augment Trial	★ 2803-6202	Right #0 10mm Augment Trial
2803-6112	Left #1 10mm Augment Trial	2803-6212	Right #1 10mm Augment Trial
2803-6122	Left #2 10mm Augment Trial	2803-6222	Right #2 10mm Augment Trial
2803-6132	Left #3 10mm Augment Trial	2803-6232	Right #3 10mm Augment Trial
2803-6142	Left #4 10mm Augment Trial	2803-6242	Right #4 10mm Augment Trial
2803-6152	Left #5 10mm Augment Trial	2803-6252	Right #5 10mm Augment Trial
2803-6162	Left #6 10mm Augment Trial	2803-6262	Right #6 10mm Augment Trial
★ 2803-6172	Left #7 10mm Augment Trial	★ 2803-6272	Right #7 10mm Augment Trial

Instruments



Number	Description
9401-5307	Screw Driver

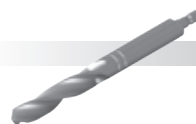

Number	Description
9403-3214-RA	Straight Stem Drill, Ø 14mm



Number	Description
9403-1302-RA	Driver Handle



Number	Description
9403-5111	Tibial Augment Resection Guide Adaptor



Number	Description
9403-2105-RB	Tibial Drill Guide, CMA



Number	Description
9403-5331-RA	Screw Deiver Adaptor, T20



Number	Description
9403-2119-RE	Tibial Augment Resection Guide, Left
9403-2219-RE	Tibial Augment Resection Guide, Right



Number	Description
9403-5340	Stem Impactor



Number	Description
9403-3002	CMA Twist Drill 3.2mm

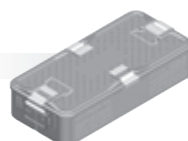

Number	Description
9303-8052	U2 Knee CMA Case

Safety Statement of “UNITED” U2 Total Knee System CMA Type

Important

This Essential Product Information sheet does not include all of the information necessary for selection and use of a device. Please see full labeling for all necessary information

INDICATIONS

This device is indicated in knee arthroplasty for reduction or relief of pain and/or improved knee function in skeletally mature patients with severe knee pain and disability due to rheumatoid arthritis, osteoarthritis, primary and secondary traumatic arthritis, polyarthritis, collagen disorders, avascular necrosis of the femoral condyle or pseudogout, posttraumatic loss of joint configuration, particularly when there is patellofemoral erosion, dysfunction or prior patellectomy, moderate valgus, varus, or flexion contraction. This device may also be indicated in the salvage or previously failed surgical attempts or for knee in which satisfactory stability in flexion cannot be obtained at the time of surgery. This device system is designed for cemented use only.

CONTRAINDICATIONS

The U2 Tibial Baseplate, CMA type is contraindicated in patients who with:

- any active or suspected latent of infection in the affected joint.
- skeletal immaturity.
- either mental or neuromuscular disorders which would create an unacceptable risk of prosthesis instability or complications in postoperative care
- rheumatoid arthritis and an ulcer of the skin or a history of recurrent breakdown of the skin.

ADVERSE EFFECTS

Potential adverse effects include infection, loosening of the components, breakage or bending of the components, or change in position of the components. Dislocation can occur due to inappropriate patient activity, trauma or other biomechanical considerations. Loosening may result from inadequate initial fixation, latent infection, premature loading of the prosthesis, component malalignment, osteolysis or trauma. Breakage or bending may result due to inadequate support of the component by the underlying bone or poor component fixation. Wear of polyethylene components has occurred and literature reports have associated its occurrence with bone resorption, loosening and infection. Other potential adverse effects of total knee surgery include genitourinary disorders; gastrointestinal disorders; neurovascular damage, thromboembolic disease, myocardial infarction and other less common adverse effects. Adverse effects may necessitate reoperation, revision, arthrodesis of the involved joint, and/or amputation of the limb. Due to the many biological, mechanical and physicochemical factors which affect these devices, the components cannot be expected to indefinitely withstand the activity level and loads of normal healthy bone.

WARNINGS AND PRECAUTIONS

Familiarity with and attention to appropriate surgical technique for total knee arthroplasty and the U2 Tibial Baseplate, CMA type is essential for success of the total knee procedure. Only surgeons who have reviewed the literature regarding total knee surgery and have been training in the technique should utilize the device. Patients should be instructed the limitations of the prosthesis, including, but not limited to, the impact of excessive loading through patient weight or activity, and be taught to govern their activities accordingly. If the patient is involved in an occupation or activity which includes substantial walking, running, lifting, or muscle strain, the resultant forces can cause failure of the fixation, the device, or both. The prosthesis will not restore function to the level expected with normal healthy bone, and the patient should not have unrealistic functional expectations.

Accordingly, strict adherence to the indications, contraindications, precaution and warnings for this product is essential to potentially maximize service life. Appropriate selection, placement and fixation of the total knee components are critical factors that affect implant service life. As in the case of all prosthetic implants, the durability of these components is affected by numerous biologic biomechanic and other extrinsic factors, which limit their service life.

The surgeon must not allow damage to polished bearing surfaces because this may accelerate wear of the components. Discard all damaged or mishandled implants. Keep bearing areas clean and free of debris prior to assembly. Components of the U2 Tibial Baseplate, CMA type should not be used with those of another manufacturer's total knee component since articular and dimensional compatibility cannot be assured. Femoral component and tibial insert should belong to the one single system; therefore, femoral component of U2 Total Knee System – PSA Type cannot be coupled with tibial insert of U2 Total Knee System, vice versa. Intentional removal of the plastic tibial insert after its assembly into the tibial tray results in the destruction of the plastic insert. Care should be taken not to nick or notch the surface of the tibial tray during insert removal. Return all packages with flaws in the sterile barrier to the supplier. This device is for single use only. Do not reuse and Do not resterilize. Reuse of this product will cause the risk of cross infection and unpredictable health threat.

For more information about UOC products, visit our web site at www.uoc.com.tw



Each Step We Care



www.uoc.com.tw

Contact Us

■ Taiwan

United Orthopedic Corporation

12F, No. 80, Sec. 1, Chenggong Rd, Yonghe Dist.,
New Taipei City 23452, Taiwan

Tel: +886 2 2929 4567 Fax: +886 2 2922 4567

■ Europe

UOC (Suisse) SA

Avenue Général Guisan 60A, 1009 Pully, Switzerland.
Tel: +41 (0) 21 634 70 70 Fax: +41 (0) 21 634 70 76

UOC (France)

21, Rue de la Ravinelle, 54000 Nancy, France.

Tel: +33 (0) 3 83 23 39 72 Fax: +33 (0) 3 83 23 39 10

■ China

United Medical Instrument Co. Ltd.

Room 402, Building 7, No.697, Ling ShiRoad,
Shanghai, China, 200072

Tel: +86 21 3661 8055 Fax: +86 21 6628 3031

■ EU Representative

mdi Europa GmbH

Langenhagener Strasse 71,
30855 Langenhagen, Germany

Tel: +49 511 3908 9530 Fax: +49 511 3908 9539

■ Japan

United Biomech Japan Inc.

Ginyo Bldg 4th floor, 2-9-40 Kitasaiwai, Nishi-Ku
Yokohama City, Kanagawa, 220-0004, Japan

Tel: +81 45 620 0741 Fax: +81 45 620 0742

■ USA

UOC USA Inc.

20 Fairbanks, Suite 173, Irvine, CA 92618

Tel: +1 949-328-3366 Fax: +1 949-328-3367



United Orthopedic Corporation (France) SAS

7 Allée des Peupliers, 54180 Houdemont, FRANCE
TEL. : +33 3 83 23 39 72 FAX : +33 3 83 23 39 10
Courriel : contact@uoc-france.fr

U2 Knee Size Pairing for PS Femoral and Tibial Components

Dear tender committee members,

The U2 Knee system of United Orthopedic Corporation is a comprehensive and organized total knee system are designed to restore knee function throughout a full range motion. It provides full interchangeability and multiple fixed-bearing insert options.

Hereby we declare that any of our U2 PS femoral components with reference numbers 2103-3110 to 2103-3270 can be paired with any of our U2 PS tibial inserts with reference numbers 2303-3001 to 2303-3075 (type UHMWPE), 2303-3601 to 2303-3675 (type XPE), and 2303-3801 to 2303-3875 (type E-XPE).

U2™ Knee System

Table with columns: PS Insert, CMA Baseplate, and PS Femoral Component (#1 to #7). Rows show size pairing from #0 to #7.

Sincerely,

Fabrice PROTOIS
Commercial-Director
United Orthopedic Corporation (France) SAS

Le 29/09/2020

Each Step We Care



7 Allée des Peupliers - 54180 HOUEMONT
Tél : 03 83 23 39 72 - Fax : 03 83 23 39 10
Siren : 821 381 985 - NAF 4646Z



United[®]
Orthopedic Corporation



U2 PSA[™]
Revision Knee

System

Femoral Component

- Cobalt-Chromium alloy
- 6 sizes (left/right)
- Cemented design
- Compatible with tibial inserts of all sizes
- Locking screw for securing the extension stem

Tibial Insert

- Constrained & Low constrained (LC) bearing insert
- UHMWPE (only constrained) & XPE
- 6 sizes and 8 thicknesses
- Built-in reinforcement bushing for extra structural support
- Screw fixation to increase the insert stability

Tibial Baseplate

- Titanium alloy (Ti-6Al-4V)
- 6 sizes
- Fully capture design to minimize micro-movement

Tibial Augment

- Titanium alloy (Ti-6Al-4V)
- 6 sizes and 3 thicknesses (5,10 and 15 mm)
- Screw-fixation

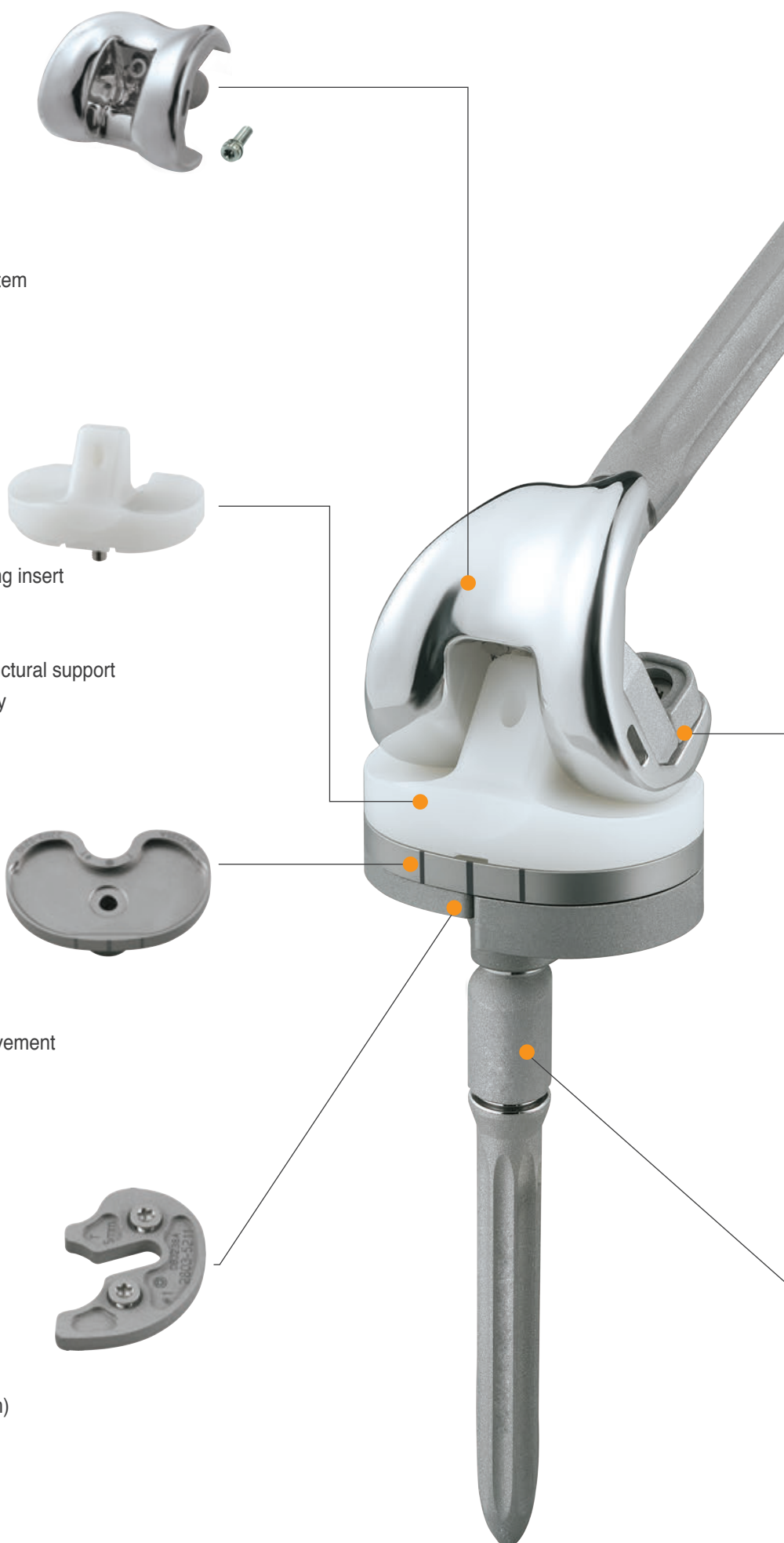

Extension Cementless Stem (Straight and Curved)

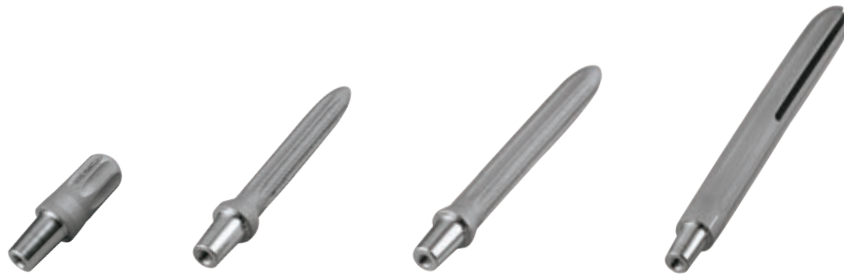

- Titanium alloy (Ti-6Al-4V)
- 5 lengths of straight stem
 - Short stem – 30 mm in length with 14 mm diameter
 - Long stem – 75, 100, 150 and 200 mm in length and comes in 6 diameters
- Curved stem – 150 and 200 mm in length and comes in 6 diameters
- Grooves/open-slot are applied to maintain flexibility

Femoral Augment (Posterior and Distal)

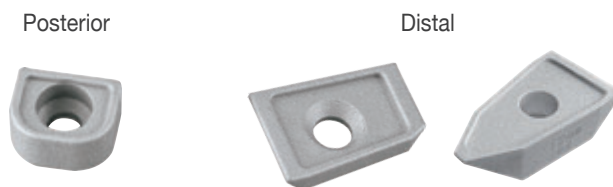

- Cobalt-Chromium alloy
- Posterior augment – 6 sizes and 2 thicknesses (4, 8 mm)
- Distal augment – 6 sizes and 4 thicknesses (4, 8, 12 and 16 mm)
- Screw fixation

Offset Adaptor



- Titanium alloy (Ti-6Al-4V)
- 2, 4, and 6 mm offset
- Fits both femoral and tibial components
- Full-range orientation for both femoral and tibial alignment

More Constraints Provide More Stability for Revision

- Maximum Range of Motion (ROM) from 129 degrees to 134 degrees

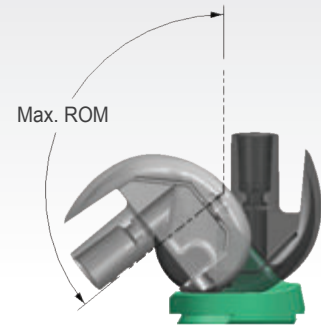

- Post and Cam early engaged for stability
- Higher jumping distance for better security

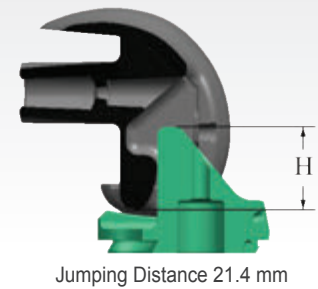
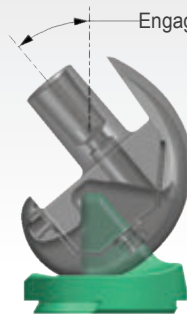

- Confined I/E rotation to $\pm 3.7^\circ$ to enhance joint stability
- Optional low constrained type allows $\pm 12.5^\circ$ I/E rotation
- Restricted varus/valgus lift-off angles to $\pm 1.4^\circ$ to increase stability

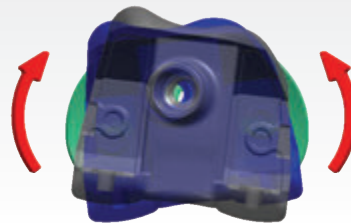

I/E Rotation

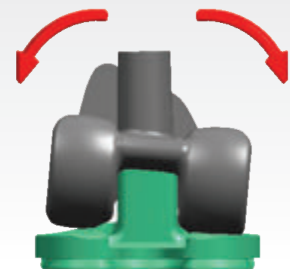

Varus/ Valgus

- Curve-on-Curve design provides better constraint and increases contact surface area to reduce wear

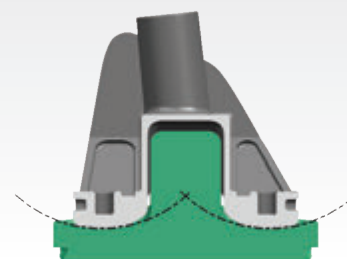

Curve-on-Curve (R 30 mm)

Features of the U2 PSA Revision Knee System

Femoral Locking Screw secures extension taper with a built-in C ring to prevent the screw from backing out.

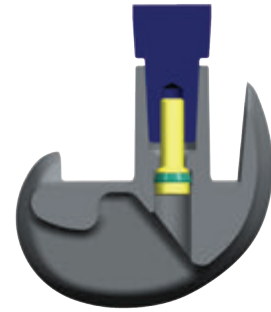

Built-in reinforcement bushing and locking screw within the tibial insert extends into the baseplate to provide additional structural support and to resist shearing force from the femur. (Patent No. US9044327)

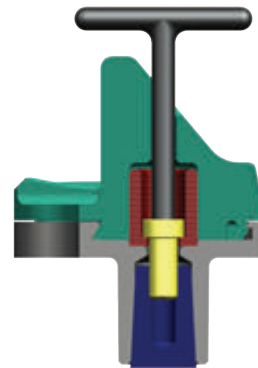

Compatible with U2 Knee Primary System

■ U2 Primary-CR

■ U2 Primary-PS

■ PSA Revision



U2 Primary-CR



U2 Primary-PS



PSA Revision



PSA Revision

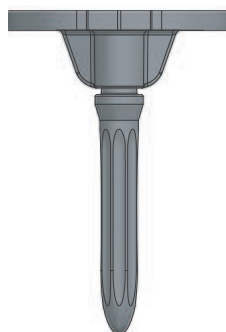

U2 PSA Component

Special Order Items

Femoral Component

Tibial Baseplate



	Left	Right
#1	2103-5110	2103-5210
#2	2103-5120	2103-5220
#3	2103-5130	2103-5230
#4	2103-5140	2103-5240
#5	2103-5150	2103-5250
#6	2103-5160	2103-5260



#1	2203-5210
#2	2203-5220
#3	2203-5230
#4	2203-5240
#5	2203-5250
#6	2203-5260

Tibial Insert



	UHMWPE							
	9 mm	11 mm	13 mm	15 mm	18 mm	21 mm	25 mm	30 mm
#1	2303-5011	2303-5012	2303-5013	2303-5014	2303-5015	2303-5016	2303-5017	2303-5018
#2	2303-5021	2303-5022	2303-5023	2303-5024	2303-5025	2303-5026	2303-5027	2303-5028
#3	2303-5031	2303-5032	2303-5033	2303-5034	2303-5035	2303-5036	2303-5037	2303-5038
#4	2303-5041	2303-5042	2303-5043	2303-5044	2303-5045	2303-5046	2303-5047	2303-5048
#5	2303-5051	2303-5052	2303-5053	2303-5054	2303-5055	2303-5056	2303-5057	2303-5058
#6	2303-5061	2303-5062	2303-5063	2303-5064	2303-5065	2303-5066	2303-5067	2303-5068

	XPE							
	9 mm	11 mm	13 mm	15 mm	18 mm	21 mm	25 mm	30 mm
#1	2303-5611	2303-5612	2303-5613	2303-5614	2303-5615	2303-5616	2303-5617	2303-5618
#2	2303-5621	2303-5622	2303-5623	2303-5624	2303-5625	2303-5626	2303-5627	2303-5628
#3	2303-5631	2303-5632	2303-5633	2303-5634	2303-5635	2303-5636	2303-5637	2303-5638
#4	2303-5641	2303-5642	2303-5643	2303-5644	2303-5645	2303-5646	2303-5647	2303-5648
#5	2303-5651	2303-5652	2303-5653	2303-5654	2303-5655	2303-5656	2303-5657	2303-5658
#6	2303-5661	2303-5662	2303-5663	2303-5664	2303-5665	2303-5666	2303-5667	2303-5668

Tibial Insert, Low Constrained



	XPE, LC type							
	9 mm	11 mm	13 mm	15 mm	18 mm	21 mm	25 mm	30 mm
#1	2303-5211	2303-5212	2303-5213	2303-5214	2303-5215	2303-5216	2303-5217	2303-5218
#2	2303-5221	2303-5222	2303-5223	2303-5224	2303-5225	2303-5226	2303-5227	2303-5228
#3	2303-5231	2303-5232	2303-5233	2303-5234	2303-5235	2303-5236	2303-5237	2303-5238
#4	2303-5241	2303-5242	2303-5243	2303-5244	2303-5245	2303-5246	2303-5247	2303-5248
#5	2303-5251	2303-5252	2303-5253	2303-5254	2303-5255	2303-5256	2303-5257	2303-5258
#6	2303-5261	2303-5262	2303-5263	2303-5264	2303-5265	2303-5266	2303-5267	2303-5268

Special Order Items

Femoral Augment Set



	Distal				Distal		Posterior	
	4 mm LM/RL	4 mm LL/RM	8 mm LM/RL	8 mm LL/RM	12 mm	16 mm	4 mm	8 mm
#1	2603-5111	2603-5211	2603-5112	2603-5212	2603-5313	2603-5314	2603-5011	2603-5012
#2	2603-5121	2603-5221	2603-5122	2603-5222	2603-5323	2603-5324	2603-5021	2603-5022
#3	2603-5131	2603-5231	2603-5132	2603-5232	2603-5333	2603-5334	2603-5031	2603-5032
#4	2603-5141	2603-5241	2603-5142	2603-5242	2603-5343	2603-5344	2603-5041	2603-5042
#5	2603-5151	2603-5251	2603-5152	2603-5252	2603-5353	2603-5354	2603-5051	2603-5052
#6	2603-5161	2603-5261	2603-5162	2603-5262	2603-5363	2603-5364	2603-5061	2603-5062

Tibial Augment



					Ti Plasma Spray	
	5 mm	10 mm	15 mm LM/RL	15 mm LL/RM	15 mm LM/RL	15 mm LL/RM
#1	2803-5211	2803-5212	2803-5113	2803-5213	2803-5313	2803-5413
#2	2803-5221	2803-5222	2803-5123	2803-5223	2803-5323	2803-5423
#3	2803-5231	2803-5232	2803-5133	2803-5233	2803-5333	2803-5433
#4	2803-5241	2803-5242	2803-5143	2803-5243	2803-5343	2803-5443
#5	2803-5251	2803-5252	2803-5153	2803-5253	2803-5353	2803-5453
#6	2803-5261	2803-5262	2803-5163	2803-5263	2803-5363	2803-5463

Extension Stem



	Straight Stem					Curved Stem	
	30 mm	75 mm	100 mm	150 mm	200 mm	150 mm	200 mm
Ø10	N/A	2703-5011	2703-5021	2703-5051	2703-5061	2703-5031	2703-5041
Ø12	N/A	2703-5012	2703-5022	2703-5052	2703-5062	2703-5032	2703-5042
Ø14	2703-5003	2703-5013	2703-5023	2703-5053	2703-5063	2703-5033	2703-5043
Ø16	N/A	2703-5014	2703-5024	2703-5054	2703-5064	2703-5034	2703-5044
Ø18	N/A	2703-5015	2703-5025	2703-5055	2703-5065	2703-5035	2703-5045
Ø20	N/A	2703-5016	2703-5026	2703-5056	2703-5066	2703-5036	2703-5046

Offset Stem Adaptor



2 mm	2903-1010
4 mm	2903-1020
6 mm	2903-1030

Femoral Screw



M5 x 14 mm	2903-1014
------------	-----------



Each Step **We Care**

Contact Us

■ Taiwan

United Orthopedic Corporation

12F, No.80, Sec.1, Chenggong Rd., Yonghe Dist.,
New Taipei City 23452, Taiwan
Tel: +886 2 2929 4567 Fax: +886 2 2922 4567

■ China

United Medical Instrument Co., Ltd.

Room 402, Building 7, No.697, Ling Shi Road,
ShangHai 200072, China
Tel: +86 21 3661 8055 Fax: +86 21 6628 3031

■ Japan

United Biomech Japan Inc.

Ginyo Bldg 4th floor, 2-9-40 Kitasaiwai, Nishi-Ku
Yokohama City, Kanagawa, 220-0004, Japan
Tel: +81 45 620 0741 Fax: +81 45 620 0742

■ USA

UOC USA Inc.

20, Fairbanks, Suite 173, Irvine 92618, CA
Tel: +1 949 328 3366 Fax: +1 949 328 3367

■ EU Representative

mdi Europa GmbH

Langenhagener Strasse 71, Langenhagen 30855, Germany
Tel: +49 511 3908 9530 Fax: +49 511 3908 9539

■ Europe

UOC (Suisse) SA

Avenue Général Guisan 60A, Pully 1009, Switzerland
Tel: +41 21 634 70 70 Fax: +41 21 634 70 76

UOC (France)

21, Rue de la Ravinelle, Nancy 54000, France
Tel: +33 3 83 23 39 72 Fax: +33 3 83 23 39 10



www.uoc.com.tw

Order Information

Special Order Items

Items requires Modular Disposable Trials

U2 Femoral Component

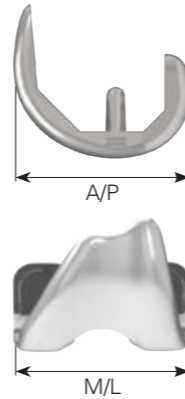

	CR		CR (Porous)	
	Left	Right	Left	Right
#1	2103-1310	2103-1410	2103-1110	2103-1210
#1.5	2103-1315	2103-1415	2103-1115	2103-1215
#2	2103-1320	2103-1420	2103-1120	2103-1220
#2.5	2103-1325	2103-1425	2103-1125	2103-1225
#3	2103-1330	2103-1430	2103-1130	2103-1230
#3.5	2103-1335	2103-1435	2103-1135	2103-1235
#4	2103-1340	2103-1440	2103-1140	2103-1240
#4.5	2103-1345	2103-1445	2103-1145	2103-1245
#5	2103-1350	2103-1450	2103-1150	2103-1250
#5.5	2103-1355	2103-1455	2103-1155	2103-1255
#6	2103-1360	2103-1460	2103-1160	2103-1260
#6.5	2103-1365	2103-1465	2103-1165	2103-1265
#7	2103-1370	2103-1470	2103-1170	2103-1270

	PS	
	Left	Right
#1	2103-3110	2103-3210
#1.5	2103-3115	2103-3215
#2	2103-3120	2103-3220
#2.5	2103-3125	2103-3225
#3	2103-3130	2103-3230
#3.5	2103-3135	2103-3235
#4	2103-3140	2103-3240
#4.5	2103-3145	2103-3245
#5	2103-3150	2103-3250
#5.5	2103-3155	2103-3255
#6	2103-3160	2103-3260
#6.5	2103-3165	2103-3265
#7	2103-3170	2103-3270

	A/P	M/L
	#1	52
#1.5	54	58
#2	56	60
#2.5	58	62
#3	60	64
#3.5	62	66
#4	64	68
#4.5	66	70
#5	68	72
#5.5	70	74
#6	72	76
#6.5	74	78
#7	76	80

Unit:mm

U2 Tibial Baseplate



	Cemented
#1	2203-3010
#2	2203-3020
#3	2203-3030
#4	2203-3040
#5	2203-3050
#6	2203-3060



	CMA
#0	2203-3200
#1	2203-3210
#2	2203-3220
#3	2203-3230
#4	2203-3240
#5	2203-3250
#6	2203-3260
#7	2203-3270

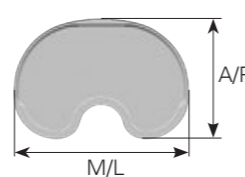

	A/P	M/L
#0	39.5	60
#1	42	63
#2	44.5	66
#3	47	69
#4	49.5	72
#5	52.5	76
#6	55.5	80
#7	58.5	84

Unit:mm

Order Information

Special Order Items

Tibial Insert (CR)



UHMWPE	CR	#0	#1	#2	#3	#4	#5	#6	#7
	9 mm	2303-1201	2303-1211	2303-1221	2303-1231	2303-1241	2303-1251	2303-1261	2303-1271
10 mm	2303-1206	2303-1216	2303-1226	2303-1236	2303-1246	2303-1256	2303-1266	2303-1276	
11 mm	2303-1202	2303-1212	2303-1222	2303-1232	2303-1242	2303-1252	2303-1262	2303-1272	
12 mm	2303-1207	2303-1217	2303-1227	2303-1237	2303-1247	2303-1257	2303-1267	2303-1277	
13 mm	2303-1203	2303-1213	2303-1223	2303-1233	2303-1243	2303-1253	2303-1263	2303-1273	
14 mm	2303-1208	2303-1218	2303-1228	2303-1238	2303-1248	2303-1258	2303-1268	2303-1278	
15 mm	2303-1204	2303-1214	2303-1224	2303-1234	2303-1244	2303-1254	2303-1264	2303-1274	
16 mm	2303-1209	2303-1219	2303-1229	2303-1239	2303-1249	2303-1259	2303-1269	2303-1279	
17 mm	2303-1200	2303-1210	2303-1220	2303-1230	2303-1240	2303-1250	2303-1260	2303-1270	
18 mm	2303-1205	2303-1215	2303-1225	2303-1235	2303-1245	2303-1255	2303-1265	2303-1275	

XPE	XCR	#0	#1	#2	#3	#4	#5	#6	#7
	9 mm	2303-1601	2303-1611	2303-1621	2303-1631	2303-1641	2303-1651	2303-1661	2303-1671
10 mm	2303-1606	2303-1616	2303-1626	2303-1636	2303-1646	2303-1656	2303-1666	2303-1676	
11 mm	2303-1602	2303-1612	2303-1622	2303-1632	2303-1642	2303-1652	2303-1662	2303-1672	
12 mm	2303-1607	2303-1617	2303-1627	2303-1637	2303-1647	2303-1657	2303-1667	2303-1677	
13 mm	2303-1603	2303-1613	2303-1623	2303-1633	2303-1643	2303-1653	2303-1663	2303-1673	
14 mm	2303-1608	2303-1618	2303-1628	2303-1638	2303-1648	2303-1658	2303-1668	2303-1678	
15 mm	2303-1604	2303-1614	2303-1624	2303-1634	2303-1644	2303-1654	2303-1664	2303-1674	
16 mm	2303-1609	2303-1619	2303-1629	2303-1639	2303-1649	2303-1659	2303-1669	2303-1679	
17 mm	2303-1600	2303-1610	2303-1620	2303-1630	2303-1640	2303-1650	2303-1660	2303-1670	
18 mm	2303-1605	2303-1615	2303-1625	2303-1635	2303-1645	2303-1655	2303-1665	2303-1675	



E-XPE	E-XCR	#0	#1	#2	#3	#4	#5	#6	#7
	9 mm	2303-1801	2303-1811	2303-1821	2303-1831	2303-1841	2303-1851	2303-1861	2303-1871
10 mm	2303-1806	2303-1816	2303-1826	2303-1836	2303-1846	2303-1856	2303-1866	2303-1876	
11 mm	2303-1802	2303-1812	2303-1822	2303-1832	2303-1842	2303-1852	2303-1862	2303-1872	
12 mm	2303-1807	2303-1817	2303-1827	2303-1837	2303-1847	2303-1857	2303-1867	2303-1877	
13 mm	2303-1803	2303-1813	2303-1823	2303-1833	2303-1843	2303-1853	2303-1863	2303-1873	
14 mm	2303-1808	2303-1818	2303-1828	2303-1838	2303-1848	2303-1858	2303-1868	2303-1878	
15 mm	2303-1804	2303-1814	2303-1824	2303-1834	2303-1844	2303-1854	2303-1864	2303-1874	
16 mm	2303-1809	2303-1819	2303-1829	2303-1839	2303-1849	2303-1859	2303-1869	2303-1879	
17 mm	2303-1800	2303-1810	2303-1820	2303-1830	2303-1840	2303-1850	2303-1860	2303-1870	
18 mm	2303-1805	2303-1815	2303-1825	2303-1835	2303-1845	2303-1855	2303-1865	2303-1875	

Order Information

Tibial Insert (UC)



XUC		#0	#1	#2	#3	#4	#5	#6	#7
XPE	9 mm	2303-1401	2303-1411	2303-1421	2303-1431	2303-1441	2303-1451	2303-1461	2303-1471
	10 mm	2303-1406	2303-1416	2303-1426	2303-1436	2303-1446	2303-1456	2303-1466	2303-1476
	11 mm	2303-1402	2303-1412	2303-1422	2303-1432	2303-1442	2303-1452	2303-1462	2303-1472
	12 mm	2303-1407	2303-1417	2303-1427	2303-1437	2303-1447	2303-1457	2303-1467	2303-1477
	13 mm	2303-1403	2303-1413	2303-1423	2303-1433	2303-1443	2303-1453	2303-1463	2303-1473
	14 mm	2303-1408	2303-1418	2303-1428	2303-1438	2303-1448	2303-1458	2303-1468	2303-1478
	15 mm	2303-1404	2303-1414	2303-1424	2303-1434	2303-1444	2303-1454	2303-1464	2303-1474
	16 mm	2303-1409	2303-1419	2303-1429	2303-1439	2303-1449	2303-1459	2303-1469	2303-1479
	17 mm	2303-1400	2303-1410	2303-1420	2303-1430	2303-1440	2303-1450	2303-1460	2303-1470
	18 mm	2303-1405	2303-1415	2303-1425	2303-1435	2303-1445	2303-1455	2303-1465	2303-1475

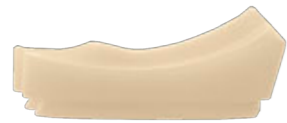

E-XUC		#0	#1	#2	#3	#4	#5	#6	#7
E-XPE	9 mm	2303-1701	2303-1711	2303-1721	2303-1731	2303-1741	2303-1751	2303-1761	2303-1771
	10 mm	2303-1706	2303-1716	2303-1726	2303-1736	2303-1746	2303-1756	2303-1766	2303-1776
	11 mm	2303-1702	2303-1712	2303-1722	2303-1732	2303-1742	2303-1752	2303-1762	2303-1772
	12 mm	2303-1707	2303-1717	2303-1727	2303-1737	2303-1747	2303-1757	2303-1767	2303-1777
	13 mm	2303-1703	2303-1713	2303-1723	2303-1733	2303-1743	2303-1753	2303-1763	2303-1773
	14 mm	2303-1708	2303-1718	2303-1728	2303-1738	2303-1748	2303-1758	2303-1768	2303-1778
	15 mm	2303-1704	2303-1714	2303-1724	2303-1734	2303-1744	2303-1754	2303-1764	2303-1774
	16 mm	2303-1709	2303-1719	2303-1729	2303-1739	2303-1749	2303-1759	2303-1769	2303-1779
	17 mm	2303-1700	2303-1710	2303-1720	2303-1730	2303-1740	2303-1750	2303-1760	2303-1770
18 mm	2303-1705	2303-1715	2303-1725	2303-1735	2303-1745	2303-1755	2303-1765	2303-1775	

Order Information

Tibial Insert (PS)



PS		#0	#1	#2	#3	#4	#5	#6	#7
UHMWPE	9 mm	2303-3001	2303-3011	2303-3021	2303-3031	2303-3041	2303-3051	2303-3061	2303-3071
	10 mm	2303-3006	2303-3016	2303-3026	2303-3036	2303-3046	2303-3056	2303-3066	2303-3076
	11 mm	2303-3002	2303-3012	2303-3022	2303-3032	2303-3042	2303-3052	2303-3062	2303-3072
	12 mm	2303-3007	2303-3017	2303-3027	2303-3037	2303-3047	2303-3057	2303-3067	2303-3077
	13 mm	2303-3003	2303-3013	2303-3023	2303-3033	2303-3043	2303-3053	2303-3063	2303-3073
	14 mm	2303-3008	2303-3018	2303-3028	2303-3038	2303-3048	2303-3058	2303-3068	2303-3078
	15 mm	2303-3004	2303-3014	2303-3024	2303-3034	2303-3044	2303-3054	2303-3064	2303-3074
	16 mm	N/A	2303-3019	2303-3029	2303-3039	2303-3049	2303-3059	2303-3069	2303-3079
	17 mm	N/A	2303-3010	2303-3020	2303-3030	2303-3040	2303-3050	2303-3060	2303-3070
	18 mm	N/A	2303-3015	2303-3025	2303-3035	2303-3045	2303-3055	2303-3065	2303-3075

XPS		#0	#1	#2	#3	#4	#5	#6	#7
XPE	9 mm	2303-3601	2303-3611	2303-3621	2303-3631	2303-3641	2303-3651	2303-3661	2303-3671
	10 mm	2303-3606	2303-3616	2303-3626	2303-3636	2303-3646	2303-3656	2303-3666	2303-3676
	11 mm	2303-3602	2303-3612	2303-3622	2303-3632	2303-3642	2303-3652	2303-3662	2303-3672
	12 mm	2303-3607	2303-3617	2303-3627	2303-3637	2303-3647	2303-3657	2303-3667	2303-3677
	13 mm	2303-3603	2303-3613	2303-3623	2303-3633	2303-3643	2303-3653	2303-3663	2303-3673
	14 mm	2303-3608	2303-3618	2303-3628	2303-3638	2303-3648	2303-3658	2303-3668	2303-3678
	15 mm	2303-3604	2303-3614	2303-3624	2303-3634	2303-3644	2303-3654	2303-3664	2303-3674
	16 mm	N/A	2303-3619	2303-3629	2303-3639	2303-3649	2303-3659	2303-3669	2303-3679
	17 mm	N/A	2303-3610	2303-3620	2303-3630	2303-3640	2303-3650	2303-3660	2303-3670
	18 mm	N/A	2303-3615	2303-3625	2303-3635	2303-3645	2303-3655	2303-3665	2303-3675



E-XPS		#0	#1	#2	#3	#4	#5	#6	#7
E-XPE	9 mm	2303-3801	2303-3811	2303-3821	2303-3831	2303-3841	2303-3851	2303-3861	2303-3871
	10 mm	2303-3806	2303-3816	2303-3826	2303-3836	2303-3846	2303-3856	2303-3866	2303-3876
	11 mm	2303-3802	2303-3812	2303-3822	2303-3832	2303-3842	2303-3852	2303-3862	2303-3872
	12 mm	2303-3807	2303-3817	2303-3827	2303-3837	2303-3847	2303-3857	2303-3867	2303-3877
	13 mm	2303-3803	2303-3813	2303-3823	2303-3833	2303-3843	2303-3853	2303-3863	2303-3873
	14 mm	2303-3808	2303-3818	2303-3828	2303-3838	2303-3848	2303-3858	2303-3868	2303-3878
	15 mm	2303-3804	2303-3814	2303-3824	2303-3834	2303-3844	2303-3854	2303-3864	2303-3874
	16 mm	N/A	2303-3819	2303-3829	2303-3839	2303-3849	2303-3859	2303-3869	2303-3879
	17 mm	N/A	2303-3810	2303-3820	2303-3830	2303-3840	2303-3850	2303-3860	2303-3870
	18 mm	N/A	2303-3815	2303-3825	2303-3835	2303-3845	2303-3855	2303-3865	2303-3875

Order Information

All Poly Tibial Component



APT-CR		#1	#2	#3	#4	#5	#6	#7
UHMWPE	9 mm	2203-1011	2203-1021	2203-1031	2203-1041	2203-1051	2203-1061	2203-1071
	11 mm	2203-1012	2203-1022	2203-1032	2203-1042	2203-1052	2203-1062	2203-1072
	13 mm	2203-1013	2203-1023	2203-1033	2203-1043	2203-1053	2203-1063	2203-1073
	15 mm	2203-1014	2203-1024	2203-1034	2203-1044	2203-1054	2203-1064	2203-1074
	18 mm	2203-1015	2203-1025	2203-1035	2203-1045	2203-1055	2203-1065	2203-1075



APT-PS		#1	#2	#3	#4	#5	#6	#7
UHMWPE	9 mm	2203-1211	2203-1221	2203-1231	2203-1241	2203-1251	2203-1261	2203-1271
	11 mm	2203-1212	2203-1222	2203-1232	2203-1242	2203-1252	2203-1262	2203-1272
	13 mm	2203-1213	2203-1223	2203-1233	2203-1243	2203-1253	2203-1263	2203-1273
	15 mm	2203-1214	2203-1224	2203-1234	2203-1244	2203-1254	2203-1264	2203-1274
	18 mm	2203-1215	2203-1225	2203-1235	2203-1245	2203-1255	2203-1265	2203-1275



APT-UC		#1	#2	#3	#4	#5	#6	#7
UHMWPE	9 mm	2203-1411	2203-1421	2203-1431	2203-1441	2203-1451	2203-1461	2203-1471
	11 mm	2203-1412	2203-1422	2203-1432	2203-1442	2203-1452	2203-1462	2203-1472
	13 mm	2203-1413	2203-1423	2203-1433	2203-1443	2203-1453	2203-1463	2203-1473
	15 mm	2203-1414	2203-1424	2203-1434	2203-1444	2203-1454	2203-1464	2203-1474
	18 mm	2203-1415	2203-1425	2203-1435	2203-1445	2203-1455	2203-1465	2203-1475

Order Information

Patella Component

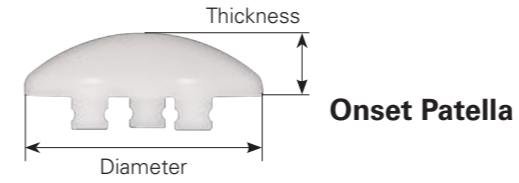

	XS	S	M	L	XL	XXL	EL
UHMWPE	2403-1010	2403-1020	2403-1030	2403-1040	2403-1050	2403-1060	2403-1070
XPE	2403-3210	2403-3220	2403-3230	2403-3240	2403-3250	2403-3260	2403-3270
E-XPE	2403-5210	2403-5220	2403-5230	2403-5240	2403-5250	2403-5260	2403-5270

Thickness	7	8	8.5	9	9.5	10	10.5
Diameter	26	29	32	35	38	41	44

Unit : mm

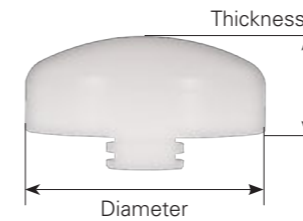

Inset Patella

	S	M	L	XL
UHMWPE	2401-1010	2401-1020	2401-1030	2401-1040
XPE	2403-3010	2403-3020	2403-3030	2403-3040
E-XPE	2403-5010	2403-5020	2403-5030	2403-5040

Thickness	8	10	10	10
Diameter	22	25	28	32

Unit : mm

Extensions (CMA)



Augment



Straight Stem

Ø14 x 30 mm

2703-5003

	#0	#1	#2	#3	#4	#5	#6	#7
5 mm	2803-5201	2803-5211	2803-5221	2803-5231	2803-5241	2803-5251	2803-5261	2803-5271
10 mm	2803-5202	2803-5212	2803-5222	2803-5232	2803-5242	2803-5252	2803-5262	2803-5272

Reference

[1] Data held on file. United Orthopedic Corporation

Instrument Tray Guide with Modular Disposable Trials (MDT)

1.5 Trays with Modular Disposable Trials

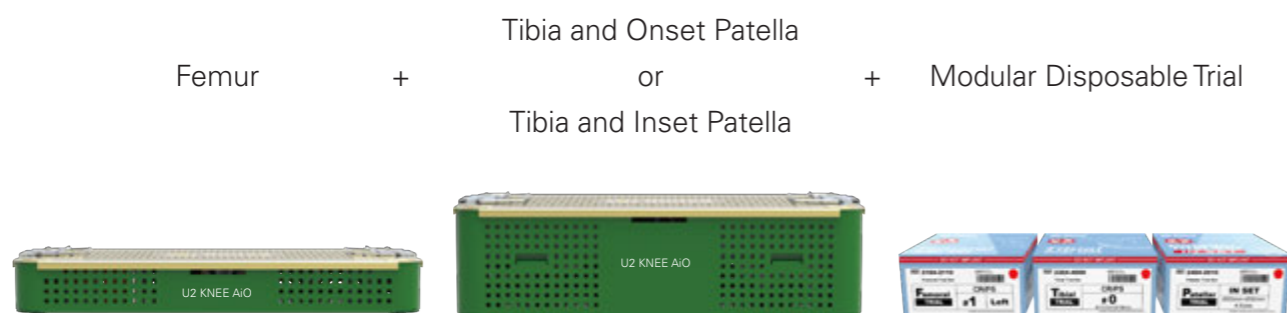

<p>PS/CR Femoral Component (Lt/Rt)</p> <p>13 Sizes</p>	<p>Tibial Insert</p> <p>8 Sizes 10 Thicknesses</p>	<p>Tibial Baseplate</p> <p>8 Sizes</p>	<p>Onset Patella</p> <p>7 Sizes</p> <p>Inset Patella</p> <p>4 Sizes</p>
--	--	--	---

Optional: CMA Baseplate Augments/Extension Stem

<p>CMA Case</p>	<p>Augment</p> <p>8 Sizes 5/10 mm</p>	<p>Extension Stem</p> <p>30 mm</p>
-----------------	---	------------------------------------

Instrument Tray Guide with Reusable Trials

4 Trays with Reusable Trials

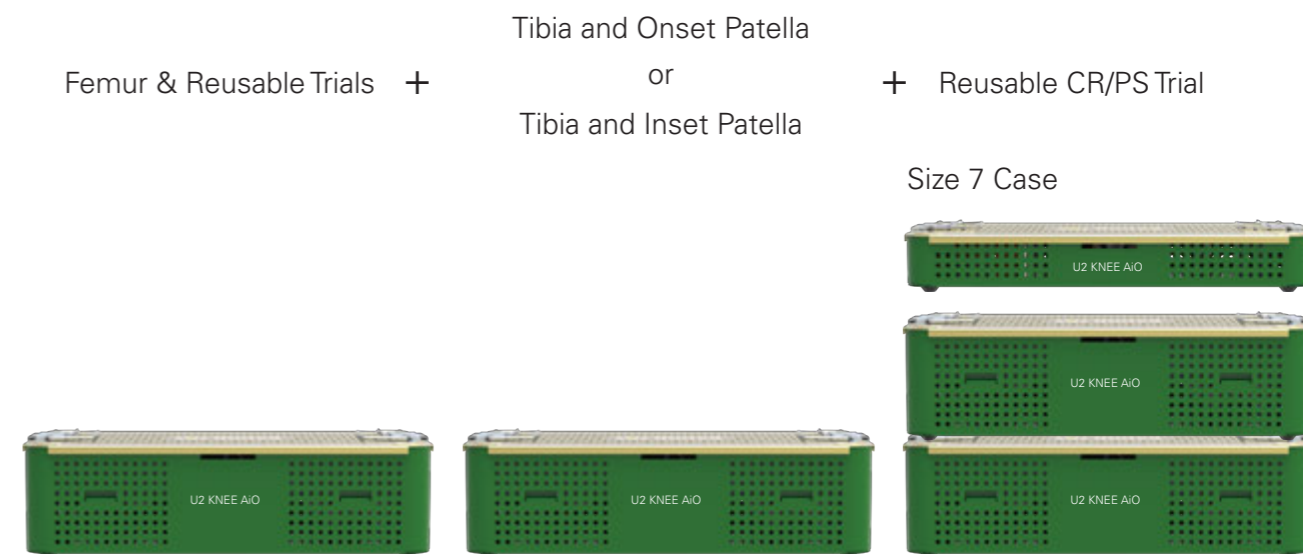

<p>PS/CR Femoral Component (Lt/Rt)</p> <p>13 Sizes</p>	<p>Tibial Insert</p> <p>8 Sizes 10 Thicknesses</p>	<p>Tibial Baseplate</p> <p>8 Sizes</p>	<p>Onset Patella</p> <p>7 Sizes</p> <p>Inset Patella</p> <p>4 Sizes</p>
--	--	--	---



Each Step
We Care

Please note that this Surgical Technique Guide has been authored in the English language. Any translations into other languages have not been reviewed or approved by United Orthopedic Corporation and their accuracy cannot be confirmed. Any translated guide should be reviewed carefully prior to use and questions regarding a Surgical Technique Guide should be directed to United Orthopedic Corporation at unitedorthopedic.com/contact

The CE mark is valid only if it is also printed on the product label.

