

Industrial Controls

Soft starters and solid-state switching devices SIRIUS 3RW55 and 3RW55 Failsafe Soft Starters



Equipment Manual

Siemens Industry Online Support	1
Safety information	2
Description	3
Mounting and dismantling	4
Connecting	5
Parameter assignment	6
Commissioning	7
Functions	8
Messages and diagnostics	9
Maintenance and service	10
Technical specifications	11
Dimension drawings	12
Circuit diagrams	13
Example circuits	A

Legal information

Warning notice system

This manual contains notices you have to observe in order to ensure your personal safety, as well as to prevent damage to property. The notices referring to your personal safety are highlighted in the manual by a safety alert symbol, notices referring only to property damage have no safety alert symbol. These notices shown below are graded according to the degree of danger.

 DANGER
indicates that death or severe personal injury will result if proper precautions are not taken.
 WARNING
indicates that death or severe personal injury may result if proper precautions are not taken.
 CAUTION
indicates that minor personal injury can result if proper precautions are not taken.
NOTICE
indicates that property damage can result if proper precautions are not taken.

If more than one degree of danger is present, the warning notice representing the highest degree of danger will be used. A notice warning of injury to persons with a safety alert symbol may also include a warning relating to property damage.

Qualified Personnel

The product/system described in this documentation may be operated only by **personnel qualified** for the specific task in accordance with the relevant documentation, in particular its warning notices and safety instructions. Qualified personnel are those who, based on their training and experience, are capable of identifying risks and avoiding potential hazards when working with these products/systems.

Proper use of Siemens products

Note the following:

 WARNING
Siemens products may only be used for the applications described in the catalog and in the relevant technical documentation. If products and components from other manufacturers are used, these must be recommended or approved by Siemens. Proper transport, storage, installation, assembly, commissioning, operation and maintenance are required to ensure that the products operate safely and without any problems. The permissible ambient conditions must be complied with. The information in the relevant documentation must be observed.

Trademarks

All names identified by ® are registered trademarks of Siemens Aktiengesellschaft. The remaining trademarks in this publication may be trademarks whose use by third parties for their own purposes could violate the rights of the owner.

Disclaimer of Liability

We have reviewed the contents of this publication to ensure consistency with the hardware and software described. Since variance cannot be precluded entirely, we cannot guarantee full consistency. However, the information in this publication is reviewed regularly and any necessary corrections are included in subsequent editions.

Table of contents

1	Siemens Industry Online Support.....	9
1.1	Support Request	11
1.2	Additional documentation	11
1.3	ID link.....	12
1.4	Change documentation	13
2	Safety information.....	15
2.1	ESD Guidelines.....	15
2.2	Five safety rules for working in or on electrical systems.....	16
2.3	Reactive power compensation.....	17
2.4	Electromagnetic compatibility (EMC) according to IEC 60947-4-1	17
2.5	Cybersecurity information.....	18
2.6	ATEX/IECEX/UKEX	18
2.6.1	Use in Class I and Class II Hazardous Locations.....	18
2.6.2	ATEX/IECEX/UKEX-certified motor overload protection	18
2.7	Failsafe	22
2.8	Protection against unauthorized actuation.....	24
2.9	Firmware update.....	24
2.10	Recycling and disposal	24
3	Description.....	25
3.1	Hardware configuration	26
3.2	Operating principle	27
3.3	3RW5 HMI High Feature	30
3.4	Options for accessing the 3RW55 and 3RW55 Failsafe soft starters.....	32
3.5	Operating modes and master control function.....	34
3.5.1	Operating modes.....	34
3.5.2	Sets the operating mode	37
3.6	Device versions	42
3.7	Areas of application and load types	45
3.8	Selection of the soft starter using the Simulation Tool for Soft Starters.....	46
3.9	Structure of the article number	46
3.10	Accessories	51
3.10.1	Accessories for 3RW55 and 3RW55 Failsafe soft starters.....	51
3.10.2	3RW5 communication module	53

3.10.3	SIRIUS Soft Starter ES (TIA Portal)	53
4	Mounting and dismantling	57
4.1	Mounting 3RW55 and 3RW55 Failsafe soft starters	57
4.2	Mounting the fan cover.....	57
4.3	Mount the 3RW55 and 3RW55 Failsafe soft starters on a level surface.....	58
4.4	Installing, mounting and removing the 3RW5 HMI High Feature	62
4.4.1	Removing the 3RW5 HMI High Feature	62
4.4.2	Installing the 3RW5 HMI High Feature in the 3RW55 or 3RW55 Failsafe soft starter	63
4.4.3	Installing the High Feature 3RW5 HMI on a flat surface	64
4.4.4	Installing the 3RW5 HMI High Feature in the control cabinet door	66
4.4.5	Replacing the hinged cover of the 3RW55 or 3RW55 Failsafe soft starter	70
5	Connecting	73
5.1	Overview of all connections of the 3RW55 soft starter	73
5.2	Overview of all connections of the 3RW55 Failsafe soft starter	75
5.3	Connecting 3RW55 and 3RW55 Failsafe soft starters.....	76
5.4	Connecting the 3RW55 and 3RW55 Failsafe soft starters to the main circuit connection (line side/motor side)	77
5.5	Mounting terminal covers on main circuit connections	78
5.6	Replacement of the box terminal blocks with size 2	80
5.7	Connecting the control terminals (screw terminals)	82
5.8	Disconnecting the control current form the screw-type terminals.....	83
5.9	Connecting the control terminals (spring-type terminals).....	84
5.10	Disconnecting the control current from the spring-loaded terminals	85
5.11	Replacing the control terminals	86
5.12	Installing the cover for the control cable duct	88
5.13	Removing the cover of the control cable duct	89
6	Parameter assignment.....	91
6.1	Parameterizing 3RW55 and 3RW55 Failsafe soft starters	91
6.2	Parameter sets	93
6.3	Application wizard	94
6.4	Suggested settings of the application wizard	95
6.5	Motor parameters	97
6.6	Design and operator controls of the High Feature 3RW5 HMI	100
6.7	Menu of the 3RW5 HMI High Feature	101
6.8	Configuring the Function selection key F1-F9 of the 3RW5 HMI High Feature	119
6.9	Configuring the start key of the 3RW5 HMI High Feature.....	121
6.10	Parameterizing the 3RW5 HMI High Feature	123

6.11	Parameterizing the 3RW55 or 3RW55 Failsafe soft starter in series / identically	125
6.11.1	Parameterizing the 3RW55 or 3RW55 Failsafe soft starter with micro SD card in series / identically	125
6.11.2	Parameterizing the 3RW55 or 3RW55 Failsafe soft starter in series / identically with SIRIUS Soft Starter ES (TIA Portal).....	126
7	Commissioning	127
7.1	Commissioning 3RW55 and 3RW55 Failsafe soft starters.....	127
7.2	Sealing 3RW55 and 3RW55 Failsafe soft starters (optional)	128
7.3	First commissioning of the High Feature 3RW5 HMI.....	129
8	Functions	131
8.1	Start-up	133
8.1.1	Starting modes	133
8.1.2	Automatic parameterization	134
8.1.3	Soft starting with voltage ramp	136
8.1.4	Soft starting with torque control	139
8.1.5	Soft starting with voltage ramp and current limiting	142
8.1.6	Soft starting with torque control and current limiting	144
8.1.7	Direct-on-line starting	145
8.1.8	Motor heating.....	145
8.1.9	Breakaway pulse for startup functions	146
8.2	Run-down.....	148
8.2.1	Stopping modes.....	148
8.2.2	Coasting down.....	150
8.2.3	Voltage ramp	151
8.2.4	Torque control	152
8.2.5	Pump stop	154
8.2.6	DC braking.....	156
8.2.6.1	DC braking with external braking contactors.....	156
8.2.6.2	Dynamic DC braking without contactor	159
8.2.6.3	Reversing DC braking with a reversing contactor assembly	162
8.2.6.4	Sensorless motor standstill detection.....	164
8.2.6.5	External motor standstill detection	165
8.2.7	Alternative stopping.....	165
8.3	Motor protection.....	168
8.3.1	Electronic motor overload protection.....	168
8.3.2	Temperature sensor	171
8.4	Intrinsic device protection	173
8.5	Creep speed.....	174
8.6	Reset	175
8.7	Quick-stop	176
8.8	Condition Monitoring.....	176
8.8.1	Condition Monitoring for plant monitoring	176
8.8.2	Current monitoring	177
8.8.3	Active power monitoring.....	179
8.8.4	Switching frequency monitoring	180

8.8.5	Starting time monitoring.....	183
8.8.6	Pump cleaning function	184
8.9	Asymmetry	188
8.10	Ground fault	189
8.11	Emergency mode.....	191
8.11.1	Emergency start.....	191
8.11.2	Emergency run	193
8.12	Inputs	196
8.12.1	Overview of the input functions	196
8.12.2	Process data and process images	198
8.13	Outputs	200
8.13.1	Digital outputs	200
8.13.2	Analog output	204
8.13.3	Cyclic send data	207
8.14	ATEX/IECEX/UKEX	208
8.14.1	ATEX/IECEX/UKEX-certified motor overload protection	208
8.14.2	Ex operation	209
8.15	Failsafe	214
8.15.1	Operating principle	214
8.15.2	Resetting safety-related shutoff	215
8.16	Functions under "Additional parameters"	216
8.17	Setting the date and time.....	220
8.18	Trace	222
8.19	Test mode.....	223
8.19.1	Test with small load	224
8.19.2	Simulation	226
8.20	Monitoring	229
8.20.1	Monitoring the measured values of the 3RW55 soft starter with the 3RW5 HMI High Feature.....	229
8.20.2	Graphical display of measured values on the 3RW5 HMI High Feature	231
8.20.3	Monitoring the process image of the 3RW55 soft starter with the 3RW5 HMI High Feature...	233
8.21	Control via 3RW5 HMI High Feature.....	234
8.22	Overview	236
8.23	Local access protection and user account administration	239
8.23.1	General advice on using PINs	239
8.23.2	Local access protection (PIN)	239
8.23.2.1	Define PIN.....	240
8.23.2.2	Change PIN.....	241
8.23.2.3	Delete PIN.....	241
8.23.3	Setting up user account management	242
8.23.4	User login and logout.....	244
8.24	Micro SD card	245
8.25	Reloading a language for the High Feature 3RW5 HMI	247

9	Messages and diagnostics	249
9.1	Diagnostics options.....	249
9.2	LED display and displays on the HMI High Feature.....	249
9.2.1	Overview of the device LEDs on the 3RW55 and 3RW55 Failsafe soft starters	249
9.2.2	Status and error displays	250
9.2.3	Overview of LEDs on High Feature 3RW5 HMI.....	251
9.2.4	Displays on the HMI High Feature.....	252
9.3	Warnings and remedial measures of the 3RW55 and 3RW55 Failsafe soft starters.....	253
9.4	Errors and remedial actions of the 3RW55 and 3RW55 Failsafe soft starters.....	255
9.5	Faults and remedial actions of the 3RW5 HMI High Feature	259
9.6	Performing diagnostics on the 3RW55 and 3RW55 Failsafe soft starters using the 3RW5 HMI High Feature.....	260
9.7	Execute HMI diagnostics with the 3RW5 HMI High Feature.....	266
9.8	Performing diagnostics of the 3RW5 communication module with the 3RW5 HMI High Feature.....	266
9.9	Self-test (user-test)	267
9.10	Logbooks.....	268
9.11	Save service data to micro SD card	269
10	Maintenance and service	271
10.1	Maintenance and repairs.....	271
10.2	Replacing the fan	271
10.3	Firmware update.....	277
10.4	Performing firmware update with micro SD card (3RW5 HMI High Feature)	279
10.5	Restoring factory setting	280
10.5.1	Restoring the factory settings via High Feature 3RW5 HMI	281
10.5.2	Restoring the factory settings with the Master RESET button via 3RW5 HMI High Feature... ..	282
10.6	"Device change" function	283
10.6.1	Device change with micro SD card on the 3RW5 HMI High Feature.....	284
10.6.2	Device change with SIRIUS Soft Starter ES (TIA Portal).....	285
11	Technical specifications	287
11.1	Technical specifications in the Siemens SiePortal	287
12	Dimension drawings	289
12.1	CAX data in the Siemens SiePortal	289
12.2	Drilling pattern for 3RW5 HMI High Feature	289
13	Circuit diagrams.....	291
13.1	CAX data in the Siemens SiePortal	291
A	Example circuits.....	293
A.1	Main circuit connection.....	293

A.1.1	Feeder assembly, type of coordination 1 fuseless.....	293
A.1.2	Feeder assembly, type of coordination 1 with fuses.....	295
A.1.3	Feeder assembly, type of coordination 2.....	296
A.1.4	Inside-delta circuit.....	297
A.2	Control circuit connection.....	301
A.2.1	Control by PLC.....	301
A.2.2	Control by switch.....	302
A.2.3	Actuation of a line contactor.....	304
A.2.4	Connecting the temperature sensor.....	305
A.2.5	Connecting the evaluation unit to the analog output.....	306
A.3	Special applications.....	307
A.3.1	3RW55 and 3RW55 Failsafe soft starters in Ex operation.....	307
A.3.1.1	Type of motor connection "Standard" (inline) in Ex operation.....	307
A.3.1.2	Type of motor connection "inside delta" in Ex operation.....	309
A.3.2	3RW55 soft starter in standard (inline) circuit and stopping function DC braking with one braking contactor.....	313
A.3.3	3RW55 soft starter in standard (inline) circuit and stopping function DC braking with 2 braking contactors.....	315
A.3.4	3RW55 soft starter in standard (inline) circuit with soft starting, soft stopping and the additional function "Creep speed".....	317
A.3.5	Control via fieldbus with switchover to manual local operation.....	319
A.3.6	Pump cleaning function.....	320
A.3.6.1	Pump cleaning function with creep speed.....	320
A.3.6.2	Pump cleaning function with reversing contactor.....	322
A.3.7	Reversing duty.....	324
A.3.8	3RW55 soft starter for serial starting with 3 parameter sets.....	325
A.3.9	Soft starter for pole-changing motor with separate windings and 2 parameter sets.....	330
A.3.10	3RW55 soft starter with direct-on-line starting (DOL) as emergency start.....	332
A.3.11	Starting a Dahlander motor.....	333
A.3.12	External bypass.....	336
A.3.13	EMERGENCY STOP shutdown to SIL 1 or PL c with a 3SK1 safety relay without the 3RW55 Failsafe soft starter.....	337
A.3.14	EMERGENCY STOP shutdown up to SIL 3 or PL e with a 3SK1 safety relay without the 3RW55 Failsafe soft starter.....	341
A.4	3RW55 Failsafe soft starter.....	345
A.4.1	EMERGENCY STOP shutdown to SIL 1 STO with a 3RW55 Failsafe soft starter.....	347
A.4.2	EMERGENCY STOP shutdown to SIL 2 STO with a 3RW55 Failsafe soft starter.....	349
A.4.3	EMERGENCY STOP shutdown to SIL 3 STO with a 3RW55 Failsafe soft starter without coupling of the digital input DI to the failsafe digital input F-DI.....	353
A.4.4	EMERGENCY STOP shutdown to SIL 3 STO with a 3RW55 Failsafe soft starter with coupling of the digital input DI to the failsafe digital input F-DI.....	357
A.4.5	EMERGENCY STOP shutdown to SIL 3 STO with a 3RW55 Failsafe soft starter in conjunction with bus communication and a safety control.....	361
	Glossary.....	365
	Index.....	367

Siemens Industry Online Support

Information and service

At Siemens Industry Online Support you can obtain up-to-date information from our global support database:

- Product support
- Application examples
- Forum
- mySupport

Link: Siemens Industry Online Support (<https://support.industry.siemens.com/cs/ww/en>)

Product support

You can find information and comprehensive know-how covering all aspects of your product here:

- **FAQs**
Answers to frequently asked questions
- **Manuals/operating instructions**
Read online or download, available as PDF or individually configurable.
- **Certificates**
Clearly sorted according to approving authority, type and country.
- **Characteristics**
For support in planning and configuring your system.
- **Product announcements**
The latest information and news concerning our products.
- **Downloads**
Here you will find updates, service packs, HSPs and much more for your product.
- **Application examples**
Function blocks, background and system descriptions, performance statements, demonstration systems, and application examples, clearly explained and represented.
- **Technical data**
Technical product data for support in planning and implementing your project

Link: Product support (<https://support.industry.siemens.com/cs/ww/en/ps>)

mySupport

The following functions are available in your personal work area "mySupport":

- **Support Request**
Search for request number, product or subject
- **My filters**
With filters, you limit the content of the online support to different focal points.
- **My favorites**
With favorites you bookmark articles and products that you need frequently.
- **My notifications**
Your personal mailbox for exchanging information and managing your contacts. You can compile your own individual newsletter in the "Notifications" section.
- **My products**
With product lists you can virtually map your control cabinet, your system or your entire automation project.
- **My documentation**
Configure your individual documentation from different manuals.
- **CAX data**
Easy access to CAX data, e.g. 3D models, 2D dimension drawings, EPLAN macros, device circuit diagrams
- **My IBase registrations**
Register your Siemens products, systems and software.

Siemens Industry Online Support app

The Siemens Industry Online Support app provides you access to all the device-specific information available on the Siemens Industry Online Support portal for a particular article number, such as operating instructions, manuals, data sheets, FAQs etc.

The Siemens Industry Online Support app is available for Android and iOS:



Android



iOS

1.1 Support Request

After you have registered, you can use the Support Request form in the online support to send your question directly to Technical Support:

Support Request:	Internet (https://www.siemens.com/support-request)
------------------	--

1.2 Additional documentation

Manuals / online help

At this point, you will find further manuals and online help that may be of interest to you for your automation system. They are available to download from the Internet free of charge. You can create your own individual system documentation in mySupport.

- 3RW5 topic page (<https://support.industry.siemens.com/cs/ww/en/view/109747404>)
- Equipment Manual for the 3RW50 soft starter (<https://support.industry.siemens.com/cs/ww/en/view/109753750>)
- Equipment Manual for the 3RW52 soft starter (<https://support.industry.siemens.com/cs/ww/en/view/109753751>)
- Equipment Manual for the 3RW55 and 3RW55 Failsafe Soft Starters (<https://support.industry.siemens.com/cs/ww/en/view/109753752>)
- Equipment Manuals for the 3RW5 soft starter (<https://support.industry.siemens.com/cs/ww/en/ps/16212/man>)
- Equipment Manual for the 3RW5 PROFINET communication modules (<https://support.industry.siemens.com/cs/ww/en/view/109753754>)
- Equipment Manual for the 3RW5 PROFIBUS communication module (<https://support.industry.siemens.com/cs/ww/en/view/109753753>)
- Equipment Manual for the 3RW5 Modbus communication modules (<https://support.industry.siemens.com/cs/ww/en/view/109753755>)
- Equipment Manual for the 3RW5 EtherNet/IP communication module (<https://support.industry.siemens.com/cs/ww/en/view/109758201>)
- Online help for SIRIUS Soft Starter ES (TIA Portal)
- Online help for STEP 7
- The EMC Directive 2014/30/EU in practice (<http://www.siemens.com/emc-guideline>)
- Industrial Control Panels and Electronic Equipment of Industrial Machinery for North America (<http://www.siemens.com/UL508A>)
- Control Panels compliant with IEC Standards and European Directives (<http://www.siemens.com/iec60204>)

Interesting links

- Manuals in Siemens Industry Online Support (<https://support.industry.siemens.com/cs/ww/en/ps/man>)
- FAQs for soft starters 3RW5 (<https://support.industry.siemens.com/cs/ww/en/ps/16212/faq>)
- Downloads for soft starters 3RW5 (<https://support.industry.siemens.com/cs/ww/en/ps/16212/dl>)
- Catalog IC 10 (<https://support.industry.siemens.com/cs/ww/en/view/109747945>)
- Product support for STEP 7 (TIA Portal) (<https://support.industry.siemens.com/cs/ww/en/ps/14672>)

1.3 ID link

ID link for the digital nameplate

The ID link is a globally unique identifier according to IEC 61406-1, which you can find as a QR code on your product. The ID link takes you to the digital nameplate of your product. Using the ID link saves paper and energy.

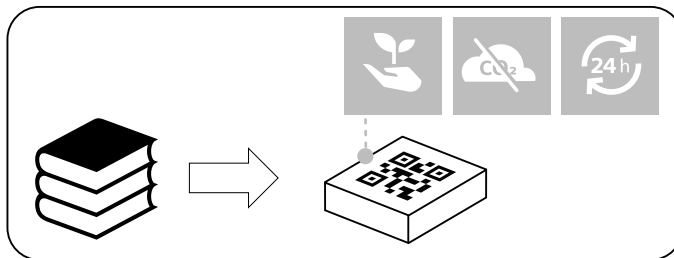

Scan the QR code on the product or on the packaging label with a smartphone camera, barcode scanner, or reader app. Call the ID-Link. In the digital nameplate, you will find product data, manuals, declarations of conformity, certificates, and other helpful information about your product.

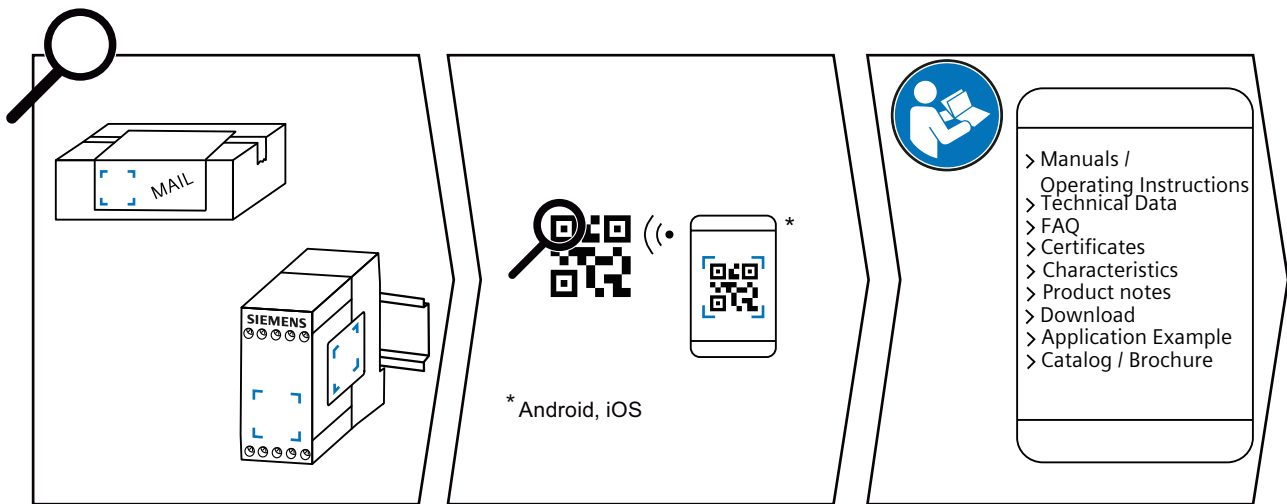

1.4 Change documentation

Release number	Changes
03/2025	<ul style="list-style-type: none"> • ID link added • Parameter "DC braking torque" added for the function "Reversing DC braking with a reversing contactor assembly" • Typical circuit diagram "EMERGENCY STOP shutdown to SIL 2 STO with a 3RW55 Failsafe soft starter" added

Safety information

2.1 ESD Guidelines

ESD

All electronic devices are equipped with large-scale integrated ICs or components. Due to their design, these electronic elements are highly sensitive to overvoltage, and thus to any electrostatic discharge.

The acronym ESD has become the established designation for such electrostatic sensitive components/devices. This is also the international abbreviation for such devices.

ESD devices are identified by the following symbol:



NOTICE

Electrostatic discharge

ESD devices can be destroyed by voltages well below the threshold of human perception. These static voltages develop when you touch a component or electrical connection of a device without having drained the static charges present on your body. The damage caused to a device by overvoltage is usually not immediately evident and is only noticed after an extended period of operation.

Electrostatic charging

Anyone who is not connected to the electrical potential of their surroundings can be electrostatically charged.

The diagram below shows the maximum electrostatic voltage which may build up on a person coming into contact with the materials specified in the diagram. These values correspond to IEC 801-2 specifications.

2.2 Five safety rules for working in or on electrical systems

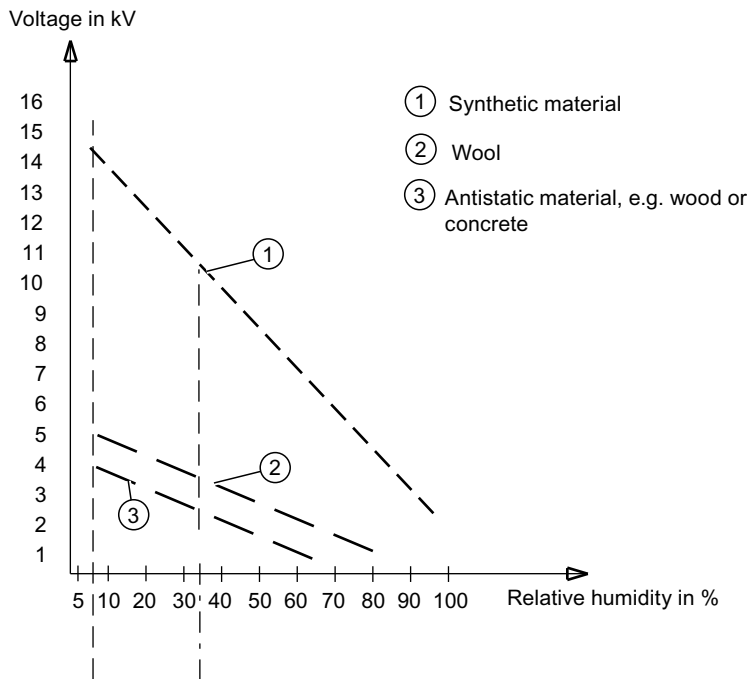

Basic protective measures against electrostatic discharge

- Make sure the grounding is good:
When handling electrostatic sensitive devices, ensure that your body, the workplace and packaging are grounded. In this way, you can avoid becoming electrostatically charged.
- Avoid direct contact:
As a general rule, only touch electrostatic sensitive devices when this is unavoidable (e.g. during maintenance work). Handle the devices without touching any chip pins or PCB traces. In this way, the discharged energy cannot reach or damage sensitive devices. Discharge your body before taking any necessary measurements on a device. Do so by touching grounded metallic parts. Use only grounded measuring instruments.

2.2 Five safety rules for working in or on electrical systems

A set of rules, which are summarized in DIN VDE 0105 as the "five safety rules", are defined for working in or on electrical systems as a preventative measure against electrical accidents:

1. Isolate
2. Secure against reclosing
3. Verify absence of operating voltage
4. Ground and short-circuit
5. Provide protection against adjacent live parts

These five safety rules must be applied in the above order prior to starting work on an electrical system. After completing the work, proceed in the reverse order.

It is assumed that every electrically skilled person is familiar with these rules.

Explanations

1. The isolating distances between live and de-energized parts of the system must vary according to the operating voltage that is applied.
"Isolate" refers to the all-pole disconnection of live parts.
All-pole disconnection can be achieved, for example, by:
 - Switching off the miniature circuit breaker
 - Switching the electronic circuit protection device to the OFF position
 - Switching off the motor circuit breaker
 - Unscrewing fusible links
 - Removing LV HRC fuses
2. The feeder must be locked against inadvertent reconnection to ensure that it remains isolated for the duration of the work. This can be achieved, for instance, by locking the motor and system circuit breakers in the OFF position or by unscrewing the fuses and using lockable elements to prevent them from being reinserted.
3. The de-energized state of the equipment should be verified using suitable test equipment, e.g. a 2-pole voltmeter. 1-pole test pins are not suitable for this purpose. The absence of power must be established for all poles, phase to phase, and phase to N/PE.
4. Grounding and short-circuiting are only mandatory if the system has a rated voltage greater than 1 kV. In this case, the system should always be grounded first and then connected to the live parts to be short-circuited.
5. These parts should be covered, or barriers erected around them, to avoid accidental contact during the work with adjacent parts that are still live.

2.3 Reactive power compensation

Capacitors for improving the power factor (reactive power compensation)

Do not connect any capacitors to the output terminals of the 3RW5 soft starter. If capacitors are connected to the output terminals, the 3RW5 soft starter will be damaged.

Do not operate active filters, e.g. for reactive power compensation, parallel to the 3RW5 soft starter.

If you use capacitors to correct the power factor (actively or passively), you must connect them on the line side of the 3RW5 soft starter. Make sure that the capacitors do not actively control the power factor during the starting and coasting down phases. If you use a contactor disconnecter or main contactor together with the 3RW5 soft starter, the capacitors must be disconnected from the 3RW5 soft starter when the contactor is open.

You will find further information in the Internet (<https://support.industry.siemens.com/cs/ww/en/view/67131557>).

2.4 Electromagnetic compatibility (EMC) according to IEC 60947-4-1

This product is designed for Environment A. It may produce radio interference in domestic environments, in which case the user may be required to take adequate mitigation measures.

2.5 Cybersecurity information

Siemens provides products and solutions with industrial cybersecurity functions that support the secure operation of plants, systems, machines and networks.

In order to protect plants, systems, machines and networks against cyber threats, it is necessary to implement – and continuously maintain – a holistic, state-of-the-art industrial cybersecurity concept. Siemens' products and solutions constitute one element of such a concept.

Customers are responsible for preventing unauthorized access to their plants, systems, machines and networks. Such systems, machines and components should only be connected to an enterprise network or the internet if and to the extent such a connection is necessary and only when appropriate security measures (e.g. firewalls and/or network segmentation) are in place.

For additional information on industrial cybersecurity measures that may be implemented, please visit <https://www.siemens.com/cybersecurity-industry>.

Siemens' products and solutions undergo continuous development to make them more secure. Siemens strongly recommends that product updates are applied as soon as they are available and that the latest product versions are used. Use of product versions that are no longer supported, and failure to apply the latest updates may increase customer's exposure to cyber threats.

To stay informed about product updates, subscribe to the Siemens Industrial Cybersecurity RSS Feed under <https://new.siemens.com/cert>.

2.6 ATEX/IECEX/UKEX

2.6.1 Use in Class I and Class II Hazardous Locations

The components of the 3RW55 and 3RW55 Failsafe soft starters are not suitable for installation in Class I and Class II Hazardous Locations .

Use the device only in a control cabinet with at least degree of protection IP 4x.

If you have any questions, ask your ATEX/IECEX/UKEX expert.

2.6.2 ATEX/IECEX/UKEX-certified motor overload protection

Environmental conditions

Comply with the ambient conditions for which the 3RW55 and 3RW55 Failsafe soft starters are approved.

Note that the 3RW55 and 3RW55 Failsafe soft starters are approved for operation in a temperature range of -25 °C to +60 °C. Consider the derating of the rated operational current

at ambient temperatures higher than 40 °C. You will find further information on derating in the Technical specifications (Page 287) in section "Power electronics" or in Catalog IC 10 (<https://support.industry.siemens.com/cs/ww/en/view/109747945>).

Note

Temperature sensor

For ATEX/IECEX/UKEX-certified motor protection, use of the PTC type A sensor only is approved.

Note

Simulation Tool for Soft Starters

Note that the Simulation Tool for Soft Starters (Page 46) already takes into account the derating for certain ambient temperatures, when you select a suitable 3RW5 soft starter.

Parameterization of the 3RW55 and 3RW55 Failsafe soft starters

You are supported with parameterizing 3RW55 and 3RW55 Failsafe soft starters for ATEX/IECEX/UKEX applications by the menu in the 3RW5 HMI High Feature. Activate the function "Ex application" (Page 209) to deactivate impermissible settings of the ATEX/IECEX/UKEX relevant parameters. Set all relevant parameters in the same menu.

Setting the rated motor operational current

Set the 3RW55 or 3RW55 Failsafe soft starters to the rated operational current of the motor as stated on the type plate or design test certificate of the motor.

Trip class (electronic overload protection)

Make sure that the motor and the cables are dimensioned for the selected trip class.

The rated data of the 3RW55 and 3RW55 Failsafe soft starters refers to normal starting (CLASS 10E). For heavy starting (> CLASS 10E) you may have to overdimension the 3RW55 or 3RW55 Failsafe soft starter.

Parameterizing the motor protection functions (RESET setting)

Note that the "Auto RESET" setting is not permissible when operating motors in Class I and Class II Hazardous Locations.

If you have activated the function "Ex application" (Page 209), the parameter "Response to overload" is permanently set to "Turn off without restart".

Short-circuit protection

The 3RW55 and 3RW55 Failsafe soft starters do not include short-circuit protection. Make sure that short-circuit protection is provided.

Line protection

Avoid impermissibly high cable surface temperatures by correctly dimensioning conductor cross sections. Select a sufficiently large conductor cross section.

Emergency start and emergency run not permissible

If the motor is operated in Class I and Class II Hazardous Locations, the functions "emergency start" (Page 191) and "emergency run" (Page 193) are not permissible.

Cyclic test of the motor protection functions

Note that performing the self-test (user-test) without 3RW5 HMI High Feature results in loss of the certified motor overload protection according to ATEX/IECEX/UKEX and there will be no explosion protection.

Only perform the self-test (user-test) (Page 267) locally with the 3RW5 HMI High Feature to ensure that the correct 3RW55 or 3RW55 Failsafe soft starter is tested. Only in this way can the certified motor overload protection according to ATEX/IECEX/UKEX be ensured.

On 3RW55 or 3RW55 Failsafe soft starters in ATEX/IECEX/UKEX applications, perform the self-test (user-test) (Page 267) during commissioning and periodically at intervals of no more than 36 months.

Certification of the 3RW55 and 3RW55 Failsafe soft starters

Note

Firmware versions and product versions of the 3RW55 soft starter with ATEX/IECEX/UKEX certification

For 3RW55 soft starters, certified motor overload protection according to ATEX/IECEX/UKEX is only provided from firmware version V2.0 and product version E02 (does not apply to 3RW55 Failsafe soft starters).

Note that it is not possible to downgrade to a previous firmware version because, in that case, certified motor overload protection according to ATEX/IECEX/UKEX cannot be guaranteed.

The motor overload protection of the 3RW55 and 3RW55 Failsafe soft starters is ATEX/IECEX/UKEX-certified to SIL 1.

The 3RW55 and 3RW55 Failsafe soft starters are approved under Equipment Groups I and II, Category (2) or (M2) in zones "G" and "D". Zones "G" and "D" are areas in which explosive gas, vapor, mist or air mixtures and combustible dust are present:

IECEX BVS 19.0014 X [Ex]

BVS 18 ATEX F003 X

ITS22UKEX0569X

II (2)G [Ex eb Gb] [Ex db Gb] [Ex pxb Gb]¹⁾

II (2)D [Ex tb Db] [Ex pxb Db]

I (M2) [Ex db Mb]

¹⁾ For the pxb applications, pressure and flow rate monitoring are additionally required for the pressurized enclosure systems.

Type of motor connection "Standard" (inline)

Note that operation of a 3RW55 soft starter in the motor connection type "Standard" without implementing one of the two following remedial measures for the following line voltages results in loss of certified motor overload protection according to ATEX/IECEX/UKEX (does not apply to 3RW55 Failsafe soft starters):

- Soft starter 200 - 480 V: for line voltage > 440 V (+10%)
- Soft starter 200 - 600 V: for line voltage > 500 V (+10%)
- Soft starter 200 - 690 V: for line voltage > 560 V (+10%)

Depending on the circuit design, choose one of the following possibilities for ensuring certified motor overload protection according to ATEX/IECEX/UKEX:

- Use an additional line contactor in the main circuit.
Connect the line contactor at outputs 95, 96 and 98 (output 3).
You will find more information in chapter Type of motor connection "Standard" (inline) in Ex operation (Page 307).
- For a motor feeder configuration with a circuit breaker, use an additional undervoltage trip unit.
Connect the undervoltage trip unit at outputs 95, 96 and 98 (output 3).
You will find more information in chapter Connecting (Page 73).

The motor connection type "Automatic detection" is not approved for ATEX/IECEX/UKEX applications.

Type of motor connection "Inside delta"

Note that operation of a 3RW55 or 3RW55 Failsafe soft starter with motor connection type "Inside-delta" without implementing one of the two following remedial measures results in loss of certified motor overload protection according to ATEX/IECEX/UKEX:

Depending on the circuit design, choose one of the following possibilities for ensuring certified motor overload protection according to ATEX/IECEX/UKEX:

- Use an additional line contactor in the main circuit (in the supply cable or in the delta connection).
Connect the line contactor at outputs 95, 96 and 98 (output 3).
You will find more information in chapter Type of motor connection "inside delta" in Ex operation (Page 309).
- For a motor feeder configuration with a circuit breaker, use an additional undervoltage trip unit.
Connect the undervoltage trip unit at outputs 95, 96 and 98 (output 3).
You will find more information in chapter Connecting (Page 73).

The motor connection type "Automatic detection" is not approved for ATEX/IECEX/UKEX applications.

Complying with standards

Increased danger in Class I and Class II Hazardous Locations means it is necessary to comply with the following standards carefully:

- **IEC / EN 60079-14 / VDE 0165-1:** For electrical apparatus for Class I and Class II Hazardous Locations.
- **IEC / EN 60079-17:** Inspection and maintenance of electrical installations in hazardous areas.
- **EN 50495:** Safety devices required for the safe functioning of equipment with respect to explosion risks.

ATEX/IECEX/UKEX-specific safety-related data

You will find ATEX/IECEX/UKEX-specific safety data on the 3RW55 and 3RW55 Failsafe soft starters in the Technical specifications (Page 287).

Maintenance and repairs

The 3RW55 and 3RW55 Failsafe soft starters are maintenance-free. The repair of soft starters with approval according to IEC 61508 / EN ISO 13849 is only permissible in the manufacturer's plant.

Any repair to the 3RW55 and 3RW55 Failsafe soft starters that is not performed in the manufacturer's plant will result in loss of ATEX/IECEX/UKEX approval.

Restoration of the factory setting of the 3RW55 soft starter

Restoration of the factory setting of the 3RW55 or 3RW55 Failsafe soft starter in active Ex operation is only permissible via the master RESET button on the 3RW5 HMI High Feature. This resets the parameters of the 3RW55 and 3RW55 Failsafe soft starters to the factory settings.

After restoration of the factory settings, you have to parameterize the 3RW55 and 3RW55 Failsafe soft starters again for use in Class I and Class II Hazardous Locations.

You will find further information on parameterization of the 3RW55 and 3RW55 Failsafe soft starters for use in Class I and Class II Hazardous Locations in chapter Ex operation (Page 209).

2.7 Failsafe



WARNING

**Loss of the safety function due to incorrectly set rated operational current I_e .
Can cause death or serious injury.**

Using a motor with too low rated operational current I_e can disable error detection mechanisms. Safety-related shutoff by the safety function "Safe Torque Off" (STO) can no longer be guaranteed.

Make sure that the rated operational current I_e of the motor is in the range of the settable rated operational current I_e of the 3RW55 Failsafe soft starter used.

⚠ WARNING

**Loss of the safety function due to restricted diagnostics.
Can cause death or serious injury.**

For diagnostics, the 3RW55 Failsafe soft starter must always be directly connected to the main supply voltage (operational voltage).

For diagnostics, always connect the 3RW55 Failsafe soft starter directly to the main supply voltage (operational voltage). Additional contact elements (e.g. a redundant contactor) must only be connected in series behind the 3RW55 Failsafe soft starter.

⚠ WARNING

**Loss of the safety function due to a failed thyristor.
Can cause death or serious injury.**

The 3RW55 Failsafe soft starter is no longer ready for operation if it contains a failed thyristor. Replace the 3RW55 Failsafe soft starter if a thyristor fails.

⚠ WARNING

**Loss of the safety function due to a short-circuit.
Can cause death or serious injury.**

- **Short-circuit protection for coordination type 1**
The 3RW55 Failsafe soft starter is defective after a short-circuit.
Replace the defective 3RW55 Failsafe soft starter.
- **Short-circuit protection for coordination type 2**
The 3RW55 Failsafe soft starter is still fully functional after a short-circuit.
Run the self-test (user-test) (Page 267) to check the safety function before continuing to use the 3RW55 Failsafe soft starter.

Note**Function test**

In continuous operation, the key safety values apply in the case of a function test interval for SIL 1 \leq 1 year and for SIL 3 \leq 1 month. The function check is part of the self-test (user-test) (Page 267).

Note**Safe state**

The basis of the safety function is the definition of the safe state. On the 3RW55 Failsafe soft starter, the safe state is an open load circuit.

Note**Safety function**

With the 3RW55 Failsafe soft starter, applications can be implemented with the safety function "Safe Torque Off" (STO) acc. to EN 61800-5-2 and stop category 0 acc. to EN 60204-1.

2.10 Recycling and disposal

Maintenance and repairs

The repair of soft starters with approval according to IEC 61508 / EN ISO 13849 is only permissible in the manufacturer's plant.

Any repair to the 3RW55 Failsafe soft starters that is not performed in the manufacturer's plant will result in loss of Failsafe approval.

2.8 Protection against unauthorized actuation

Protect freely accessible operator controls on your machine / system against unauthorized actuation if this could result in a risk or danger. Take suitable action in this regard, for example, a lockable key-operated switch.

2.9 Firmware update

To be able to use 3RW55 and 3RW55 Failsafe soft starters without any problem and with their full range of functions, ensure that all components have the latest firmware (Page 277):

- 3RW55 and 3RW55 Failsafe soft starters
- 3RW5 HMI High Feature
- 3RW5 communication module (accessory)

You will find current downloads and a history of the versions with new features on the 3RW5 topic page (<https://support.industry.siemens.com/cs/ww/en/view/109747404>).

2.10 Recycling and disposal

For environmentally-friendly recycling and disposal of your old device, contact a company certified for the disposal of used electrical and electronic equipment, and dispose of the device as specified in the regulations for your particular country.

Description

Target group

The manual is intended for everyone involved in the following tasks:

- Planning and configuring systems
- Installation
- Commissioning
- Service and maintenance

Requirements for use of 3RW5 soft starters

Basic knowledge of the following areas:

- General electrical engineering
- Drive technology
- Automation technology
- Handling the automation system and the software used

3.1 Hardware configuration

3RW55 soft starter

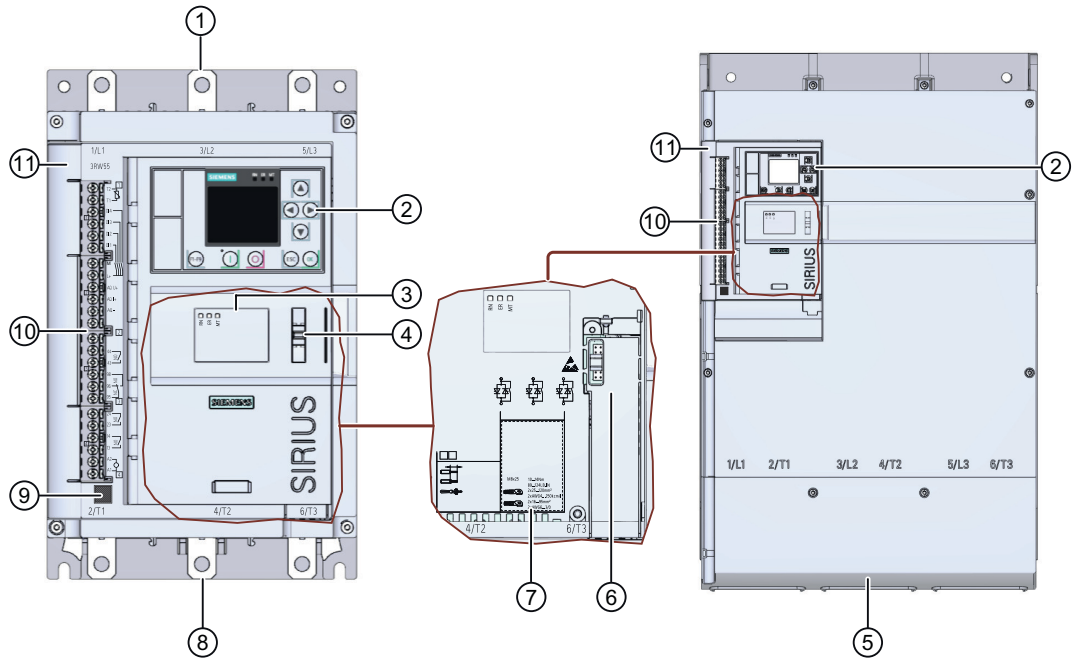

- ① Main circuit connection (line power supply)
- ② 3RW5 HMI High Feature
- ③ Diagnostics LEDs
- ④ Eye for lead seal
- ⑤ Main circuit connection (line power supply and motor) size 5
- ⑥ Slot for 3RW5 communications module (accessory)
- ⑦ Connectable conductor cross-sections
You will also find the conductor cross-sections that can be connected in the Technical specifications (Page 287).
- ⑧ Main circuit connection (motor)
- ⑨ ID link (from 01/2023)
- ⑩ Control terminals (inputs/outputs)
- ⑪ Control cable duct with cover

3RW55 Failsafe soft starter

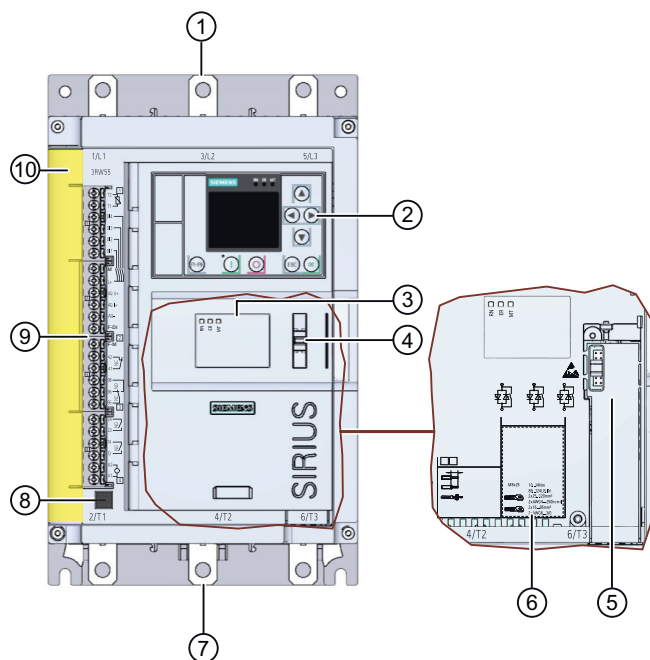

- ① Main circuit connection (line power supply)
- ② 3RW5 HMI High Feature
- ③ Diagnostics LEDs
- ④ Eye for lead seal
- ⑤ Slot for 3RW5 communications module (accessory)
- ⑥ Connectable conductor cross-sections
You will also find the conductor cross-sections that can be connected in the Technical specifications (Page 287).
- ⑦ Main circuit connection (motor)
- ⑧ ID link (from 01/2023)
- ⑨ Control terminals (inputs/outputs)
- ⑩ Control cable duct with cover

3.2 Operating principle

Soft starters are used to start three-phase induction motors with reduced torque and reduced starting current.

The 3RW55 and 3RW55 Failsafe soft starters start the motor as soon as the switch-on command is issued (t_1). During the ramp-up time (t_1 to t_3), the current is conducted via power semiconductors (switching elements), which start the motor smoothly.

The 3RW55 and 3RW55 Failsafe soft starters feature internal start-up recognition. If the 3RW55 or 3RW55 Failsafe soft starter detects a motor start-up before the ramp-up time elapses, the motor voltage is immediately increased to 100% of the line voltage (t_2). The

internal bypass contacts close and the power semiconductors are bypassed. The 3RW55 or 3RW55 Failsafe soft starter is in bypass mode.

Canceling the switch-on command (t_4) activates the stopping mode and the motor is shut down. The power semiconductors also ensure that the motor coasts down smoothly to a stop. As long as the stopping time is active (t_4 to t_5), power is still supplied to the motor. It may take longer for the motor to actually coast down to a standstill (t_6).

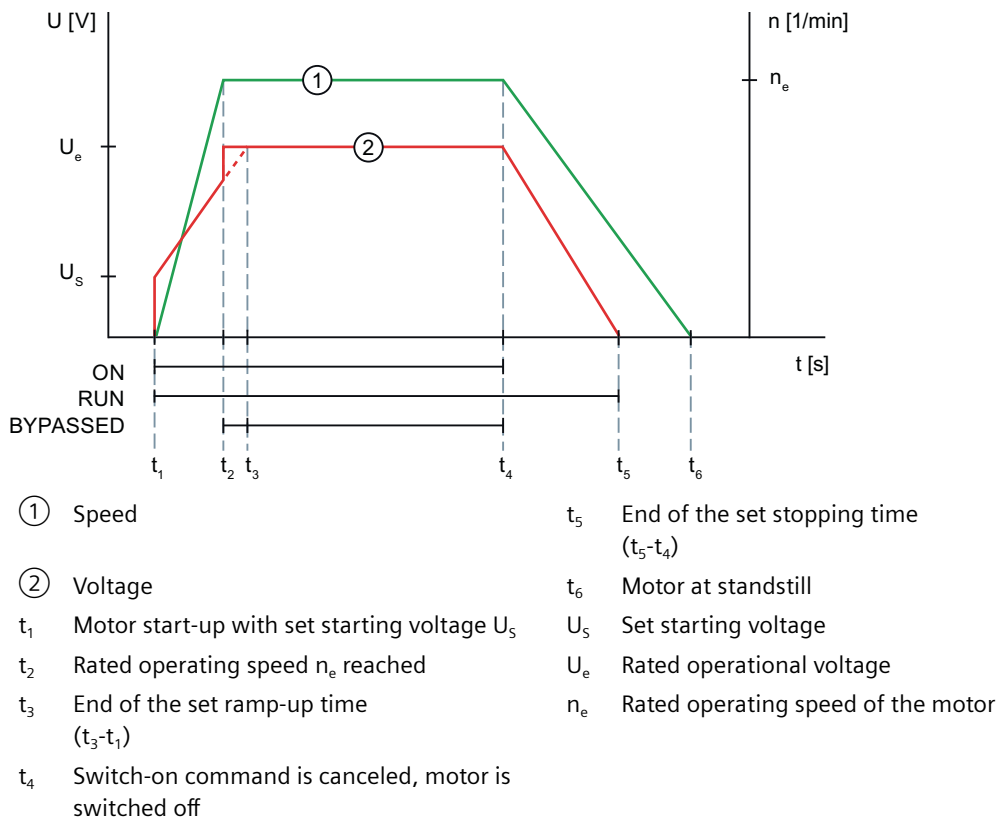

Functions of the 3RW55 and 3RW55 Failsafe soft starters

Note the information in chapter Firmware update (Page 24).

- Parameterizable **soft starting** for a smooth drive start-up
- Parameterizable **soft stopping** for a smooth drive stop
- Parameterizable **current limiting** for avoiding current peaks
- **Integrated electronic motor overload protection** with adjustable trip class (OFF, CLASS 10A, 10E, 20E, 30E)
- Integrated **intrinsic device protection** protects the 3RW55 and 3RW55 Failsafe soft starters from overload
- Extended complete motor protection by means of **thermistor motor protection** for connection of a temperature sensor
- Extended operating and diagnostic functions provided by the **High Feature 3RW5 HMI**
- **Analog output** for displaying a set measured value using an external evaluation unit

- **Automatic parameterization** simplifies system commissioning
- ATEX/IECEX/UKEX certification (for 3RW55 soft starters from firmware version V2.0 and product version E02, for 3RW55 Failsafe soft starters from firmware version V1.0 and product version E01)
- "Ex application" function supported in parameterization of the 3RW55 and 3RW55 Failsafe soft starters for operation of the motor in Class I and Class II Hazardous Locations (for 3RW55 soft starters from firmware version V2.0 and product version E02, for 3RW55 Failsafe soft starters from firmware version V1.0 and product version E01)
- **Current limit monitoring** with 4 separate limit values
- **Monitoring of switching frequency** in order to comply with application-dependent waiting/cooling times
- **Condition monitoring** for system monitoring
- Parameterizable **digital inputs and outputs**
- 3RW55 and 3RW55 Failsafe soft starters with **trace functionality** (evaluation via SIRIUS Soft Starter ES (TIA Portal))
- Connection options of the motor in **standard (inline) circuit** or in **inside-delta circuit**
- The **emergency start function** allows the plant to continue to run in the event of a fault in the plant
- **Phase asymmetry monitoring** protects the motor from asymmetrical current consumption
- **Pump cleaning function** for removing blockages and dirt from water pipes, filters, and pump blades
- **Pump stopping mode** for reduced mechanical loads and optimum control of pump stopping
- **Breakaway pulse** for overcoming high stiction, e.g. in mills
- **Access protection** by PIN and user accounts
- Micro SD card for **saving data**
- Optional **3RW5 communication module** for integration into bus systems
- **PROFenergy**: Energy-saving functions due to **stand-by mode** and **energy saving while idle** (for 3RW55 soft starters from firmware version V2.1 and 3RW55 Failsafe soft starters from firmware version V1.0 combined with a 3RW5 PROFINET communication module (accessory))
- **Application wizard** supports the commissioning of various applications
- **Parameter set change** for applications with different load conditions
- **Cascade connection** for connecting the output of a 3RW55 or 3RW55 Failsafe soft starter to the input of further soft starters
- **Serial starting** can switch on and off as many as 3 different motors one after the other
- **Web server** (for 3RW55 soft starters from firmware version V2.1.1 and 3RW55 Failsafe soft starters with firmware version higher than V1.0.0 combined with a 3RW5 PROFINET High Feature communication module from firmware version V2.0 (accessory))
- **OPC UA server** (for 3RW55 soft starters from firmware version V2.1.1 and 3RW55 Failsafe soft starters with firmware version higher than V1.0.0 combined with a 3RW5 PROFINET High Feature communication module from firmware version V2.0 (accessory))

Further functions of the 3RW55 soft starters

- The **emergency run function** permits continued operation if a power semiconductor fails (from firmware version V2.1)
- **Motor heating** for minimizing condensation inside the motor for drives outdoors
- **Creep speed function** in applications with a low counter-torque, e.g. positioning of machine tools
- **DC braking**

Further functions of the 3RW55 Failsafe soft starters

- Implementation of applications with the **safety function "Safe Torque Off" (STO)** and stop category 0 up to integrity level SIL 3 combined with the following inputs and outputs:
 - Failsafe digital input F-DI (not parameterizable)
 - Failsafe signaling output F-RQ (not parameterizable)

Additional information

You will find an overview of all of the functions of the 3RW5 soft starter in the Catalog IC 10 (<https://support.industry.siemens.com/cs/ww/en/view/109747945>).

You will find further details of the functions in chapter Functions (Page 131).

3.3 3RW5 HMI High Feature

You can use the 3RW5 HMI High Feature to parameterize, monitor and control the 3RW55 and 3RW55 Failsafe soft starters. You can remove the 3RW5 HMI High Feature from the 3RW55 or 3RW55 Failsafe soft starter and mount it in the control cabinet door or on a wall using accessories. It can be connected to the SIRIUS Soft Starter ES software (TIA Portal) via the local interface. The 3RW5 HMI High Feature has a TFT color display, LEDs for the status display, and function and control keys.

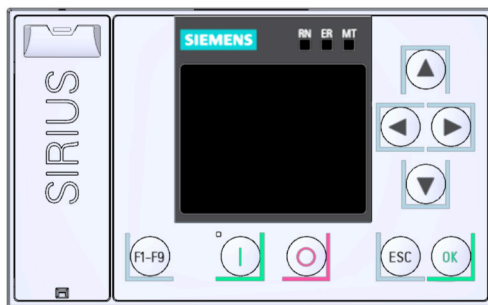

Functions

- Configurable function selection key F1-F9
- Configurable start key

- Language selection
- Starting and stopping the motor via control keys
- Local interface
- Display of error diagnoses as plain-text messages
- Display of up to 5 measured values at the same time
- Setting communication parameters of 3RW5 communication modules:
 - PROFINET standard (device name, IP parameters and other communication parameters)
 - PROFINET High Feature (device name, IP parameters and other communication parameters)
 - PROFIBUS (station address and other communication parameters)
 - Modbus TCP (IP parameters and other communication parameters)
 - Modbus RTU (station address and other communication parameters)
 - EtherNet/IP (IP parameters and other communication parameters)
- Backup of parameterization data on a micro SD card
- The display of the device LEDs of the 3RW5 HMI High Feature shows the messages of the following devices:
 - 3RW55 or 3RW55 Failsafe soft starter
 - 3RW5 HMI High Feature
 - Communication module (if there is one)
- Firmware updates can be performed using the 3RW5 HMI High Feature and a micro SD card for the following devices:
 - 3RW55 or 3RW55 Failsafe soft starter
 - 3RW5 HMI High Feature
 - Communication module (if there is one)

Note the information in chapter Firmware update (Page 24).

3.4 Options for accessing the 3RW55 and 3RW55 Failsafe soft starters

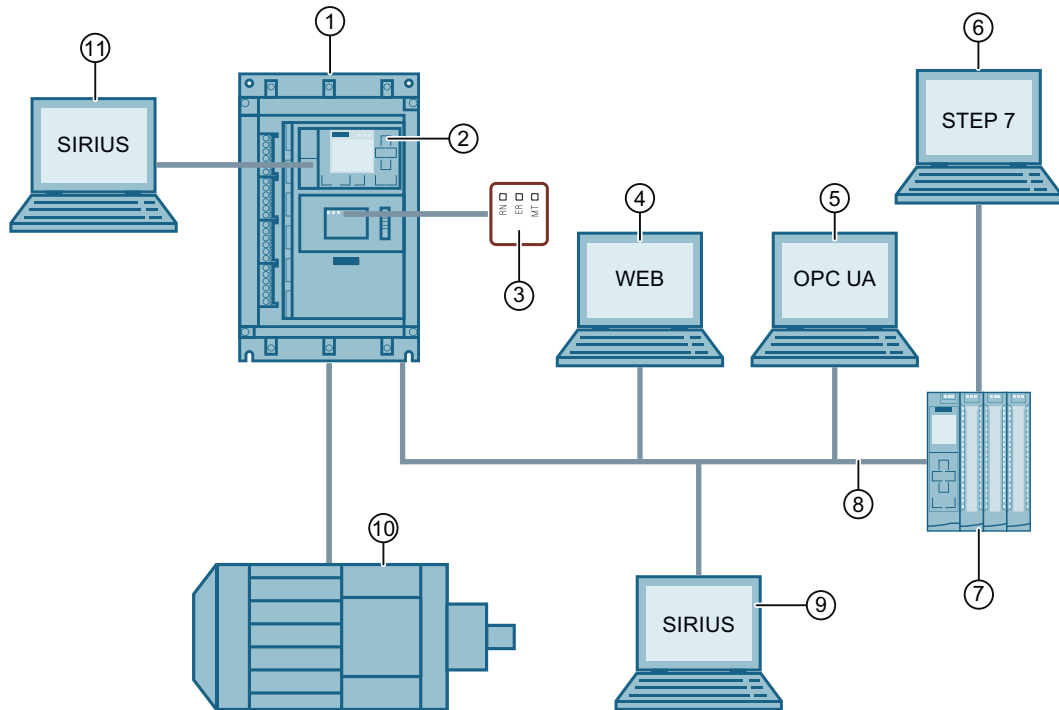

- ① SIRIUS 3RW55 or 3RW55 Failsafe soft starter (illustration similar)
- ② 3RW5 HMI High Feature
- ③ LED display on 3RW55 or 3RW55 Failsafe soft starter
- ④ PC with web client via an optional 3RW5 PROFINET High Feature communication module from firmware version V2.0
- ⑤ PC with OPC UA client via an optional 3RW5 PROFINET High Feature communication module from firmware version V2.0
- ⑥ PC or programming device with configuration software of the controller, e.g. STEP 7
- ⑦ Programmable logic controller, e.g. SIMATIC S7-1500
- ⑧ Fieldbus (via optional 3RW5 communication module)
- ⑨ PC with SIRIUS Soft Starter ES (TIA Portal) Premium / Professional via an optional 3RW5 PROFINET or PROFIBUS communication module
- ⑩ Motor
- ⑪ PC with SIRIUS Soft Starter ES (TIA Portal) via local interface on 3RW5 HMI High Feature

Options for data transfer

	Monitoring	Diagnosis	Control	Parameter setting
3RW5 HMI High Feature	✓	✓	✓	✓
SIRIUS Soft Starter ES (TIA Portal) ¹⁾	✓	✓	✓	✓
Fieldbus via 3RW5 communication module	✓ (via user program)	✓	✓	✓

3.4 Options for accessing the 3RW55 and 3RW55 Failsafe soft starters

	Monitoring	Diagnosis	Control	Parameter setting
3RW55 and 3RW55 Failsafe soft starters	LEDs	LEDs	Via digital inputs	-
Web server ²⁾	✓	✓	✓ ³⁾	-
OPC UA server ²⁾	✓	✓	-	-

1) Via the local interface on the 3RW5 HMI High Feature or via a 3RW5 PROFINET or PROFIBUS communication module

2) Only via an optional 3RW5 PROFINET High Feature communication module from firmware version V2.0

3) Login necessary with "Operating personnel" or "Service personnel" user role

3.5 Operating modes and master control function

3.5.1 Operating modes

Control source and location of control

The operating modes assign access rights to the various control sources (access sources). The control source that possesses the rights for controlling and writing access has control. As only one control source can ever have control at one time, different priorities are assigned to the modes. Read access is also possible without control.

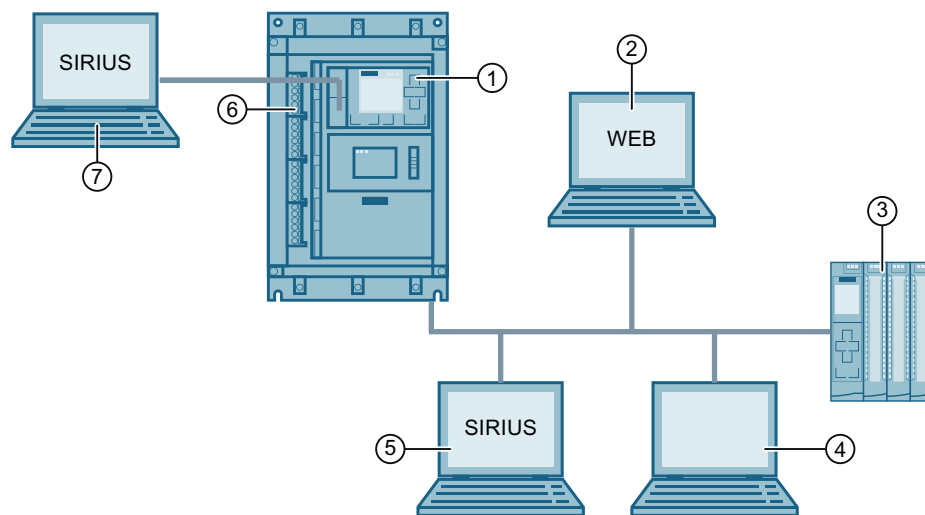

- ① Control source: 3RW5 HMI High Feature, operating mode: Manual operation local - HMI controlled
- ② Control source: Web server, operating mode: Manual operation bus - web server controlled (in combination with 3RW5 PROFINET High Feature communication module from firmware version V2.0)
- ③ Control source: PLC, operating mode: Automatic
- ④ Control source: Modbus client or Modbus master, operating mode: Automatic
- ⑤ Control source: SIRIUS Soft Starter ES (TIA Portal) Premium / Professional, operating mode: Manual operation bus - PC controlled
- ⑥ Control source: Digital inputs, operating mode: Manual operation local - Input controlled or Automatic operation - Input controlled
- ⑦ Control source: SIRIUS Soft Starter ES (TIA Portal), operating mode: Manual operation local - PC controlled

"Automatic" mode

For the "Automatic" mode you require a 3RW5 communication module and a higher-level control (e.g. PLC). The control source is connected to the 3RW55 or 3RW55 Failsafe soft starter via the 3RW5 communication module.

In "Automatic" mode, control is with a higher-level control:

- PROFINET, PROFIBUS, EtherNet/IP: Programmable logic controller (PLC)
- Modbus TCP: Modbus Client (e.g. PLC)
- Modbus RTU: Modbus Master (e.g. PLC)

Note

"Automatic operation - Input controlled" mode

The "Automatic operation - Input controlled" mode is available for the 3RW55 soft starter from firmware version V2.1 and the 3RW55 Failsafe soft starter with firmware version higher than V1.0.0 if the digital inputs have master control by activating the "Manual operation local - Input controlled" bit in the process image output (PIQ). The PLC can regain master control at any time.

Operating mode "Manual - bus"

For operating mode "Manual - bus", you require a 3RW5 PROFINET or PROFIBUS communication module and a PC with SIRIUS Soft Starter ES (TIA Portal) Premium / Professional or a web client. The control source is connected to the 3RW55 or 3RW55 Failsafe soft starter via the 3RW5 communication module.

In operating mode "Manual - bus", a control source on the fieldbus has master control:

- SIRIUS Soft Starter ES (TIA Portal) Premium / Professional
- Web server
(in combination with 3RW5 PROFINET High Feature communication module from firmware version V2.0)

Operating mode "Manual - local"

In operating mode "Manual - local", master control is with a control source directly on the 3RW55 or 3RW55 Failsafe soft starter:

- Digital inputs
- 3RW5 HMI High Feature
- SIRIUS Soft Starter ES (TIA Portal) via local interface on the 3RW5 HMI High Feature

Priorities of the operating modes

Mode		Control source	Priority
Automatic	-	Higher-level control (e.g. PLC)	Lowest
	Input controlled ¹⁾	Digital inputs ²⁾	↓
Manual operation bus (depending on the 3RW5 communication module)	-	Connection abort ³⁾	↓
	PC controlled	SIRIUS Soft Starter ES (TIA Portal) Premium / Professional	↓
	Web server controlled ⁴⁾	Web server	

3.5 Operating modes and master control function

Mode		Control source	Priority
Manual operation local	-	Connection abort ³⁾ (depending on the parameterization)	↓ ⁵⁾
	Input controlled	Digital inputs ⁶⁾	↓ ⁵⁾
	3RW5 HMI controlled	3RW5 HMI High Feature	↓
	PC controlled	SIRIUS Soft Starter ES (TIA Portal)	Highest

- 1) Supported by 3RW55 soft starter from firmware version V2.1 and 3RW55 Failsafe soft starter with firmware version higher than V1.0.0
- 2) Not possible for 3RW55 soft starters with firmware version earlier than V2.1 and 3RW55 Failsafe soft starters with firmware version V1.0.0. For 3RW55 soft starters from firmware version V2.1 and 3RW55 Failsafe soft starters with firmware version higher than V1.0.0 if the digital inputs have master control by activating the "Manual operation local - Input controlled" bit in the process image output (PIQ). The PLC can regain master control at any time.
- 3) Explanation in text below
- 4) In combination with 3RW5 PROFINET High Feature communication module from firmware version V2.0
- 5) Lowest priority without 3RW5 communication module, explanation in the following text
- 6) Possible for 3RW55 and 3RW55 Failsafe soft starters. For 3RW55 soft starters from firmware version V2.1 and 3RW55 Failsafe soft starters with firmware version higher than V1.0.0 only if the input action "Operating mode manual - local" has been parameterized and activated.

Connection abort

On failure of the bus connection or a CPU stop, the 3RW55 and 3RW55 Failsafe soft starters behave as set in the parameter "Response to CPU/Master Stop" irrespective of the mode.

If other connections between the control source and 3RW55 or 3RW55 Failsafe soft starter are aborted, master control automatically switches back to the lowest priority of the current operating mode.

- "Automatic" mode: The 3RW55 and 3RW55 Failsafe soft starters behave as set in the parameter "Response to CPU/Master Stop".
- Operating mode "Manual - bus": Control switches to "Manual - bus - Connection abort".
- Operating mode "Manual - local": Control switches either to "Manual - local - Connection abort" or to "Manual operation local - Input controlled". For certain parameter assignments, "Manual - local - Connection abort" is not possible. In the following cases, control switches to "Manual operation local - Input controlled":
 - Input action "Operating mode manual - local" is parameterized and activated.

Example: The 3RW5 HMI High Feature has control. Input 2 is assigned the input action "Operating mode manual - local" and the input action is activated. On a connection abort terminating the connection to the 3RW5 HMI High Feature, control switches to "Manual - local - input controlled".

Additional information

You will find more information on the 3RW5 communication modules in the manual for the 3RW5 communication module in question.

You will find further information about operation on failure of the bus connection to the control in the manual for the 3RW5 communication module in question.

3.5.2 Sets the operating mode

Basic behavior when the operating mode is changed

A higher-priority mode can fetch control from a lower-priority mode at any time; the reverse is not possible. Control can only be given back to the mode with the lowest priority. Control sources with higher priority must fetch control from the mode with the lowest priority.

Requirements

- A mode with lower priority can only take control back while the motor is switched off.
- For the "Automatic" mode and operating mode "Manual - bus", you require a 3RW5 communication module.

"Automatic" mode

Note that the 3RW55 and 3RW55 Failsafe soft starters switch to "Automatic" mode after the 3RW5 communication module has been installed in the 3RW55 or 3RW55 Failsafe soft starter.

Receiving control

"Automatic" mode receives control from the operating mode "Manual - bus" or "Manual - local" as follows:

- Command in SIRIUS Soft Starter ES (TIA Portal) Premium / Professional (fieldbus)
Brief overview: Window "Task Card" > Tab "Online Tools" > "SIRIUS Control Panel > Master Control > Release Control"
- Command in the web server
Web page "Control Panel" > "Master Control > Release Control"
- If the input action "Operating mode manual - local" is parameterized: By deactivating the input action "Operating mode manual - local".
- If the input action "Operating mode manual - local" is not parameterized: By deactivating the "Manual operation local - Input controlled" bit in the process image output (PIQ) or in the data table "Process image output (PIQ)" (depending on the 3RW5 communication module), "Automatic" mode receives master control from the digital inputs.
- Action "LOCAL/REMOTE" on the 3RW5 HMI High Feature
- Command in SIRIUS Soft Starter ES (TIA Portal) (local interface on the 3RW5 HMI High Feature)
Brief overview: Window "Task Card" > Tab "Online Tools" > "SIRIUS Control Panel > Master Control > Release Control"

Withdrawal of control by other control sources

In "Automatic" mode, master control can be withdrawn by any control source.

Operating mode "Manual bus - PC controlled"

Fetching control

SIRIUS Soft Starter ES (TIA Portal) Premium / Professional actively fetches master control from the "Automatic" mode or "Automatic operation - Input controlled" mode in response to a command to this effect.

Brief overview: Window "Task Card" > Tab "Online Tools" > "SIRIUS Control Panel > Master Control > Get Control"

Note

Fetching master control from "Automatic operation - Input controlled" mode

The "Automatic operation - Input controlled" mode is possible for the following 3RW5 soft starters:

- 3RW55 soft starter from firmware version V2.1
 - 3RW55 Failsafe soft starter with firmware version higher than V1.0.0
-

Giving back control

SIRIUS Soft Starter ES (TIA Portal) Premium / Professional actively passes master control to "Automatic" mode in response to a command to this effect.

Brief overview: Window "Task Card" > Tab "Online Tools" > "SIRIUS Control Panel > Master Control > Release Control"

Withdrawal of control by other control sources

Master control is withdrawn from the operating mode "Manual operation bus - PC controlled" by the operating mode "Manual - local" as follows:

- If the input action "Operating mode manual - local" is not parameterized: By activating the "Manual operation local - Input controlled" bit in the process image output (PIQ) or in the data table "Process image output (PIQ)" (depending on the 3RW5 communication module).
- If the input action "Operating mode manual - local" is parameterized: By activating the input action "Operating mode manual - local".
- Action "LOCAL/REMOTE" on the 3RW5 HMI High Feature
- Command in SIRIUS Soft Starter ES (TIA Portal) (local interface on the 3RW5 HMI High Feature)

Brief overview: Window "Task Card" > Tab "Online Tools" > "SIRIUS Control Panel > Master Control > Get Control"

Operating mode "Manual operation bus - web server controlled"

Fetching control

The web server actively fetches master control from the "Automatic" mode or "Automatic operation - Input controlled" mode in response to a command to this effect.

Web page "Control Panel" > "Master Control > Get Control"

Giving back control

The web server actively passes master control to "Automatic" mode in response to a command to this effect.

Web page "Control Panel" > "Master Control > Release Control"

Withdrawal of control by other control sources

Master control is withdrawn from the operating mode "Manual operation bus - web server controlled" by the operating mode "Manual - local" as follows:

- If the input action "Operating mode manual - local" is not parameterized: By activating the "Manual operation local - Input controlled" bit in the process image output (PIQ) or in the data table "Process image output (PIQ)" (depending on the 3RW5 communication module).
- If the input action "Operating mode manual - local" is parameterized: By activating the input action "Operating mode manual - local".
- "LOCAL / REMOTE" action on the 3RW5 HMI
- Command in SIRIUS Soft Starter ES (TIA Portal) (local interface on the 3RW5 HMI High Feature)
Brief overview: Window "Task Card" > Tab "Online Tools" > "SIRIUS Control Panel > Master Control > Get Control"

"Manual operation local - Input controlled" and "Automatic operation - Input controlled" mode**Fetching control**

The digital inputs receive control from "Automatic" mode or operating mode "Manual - bus" as follows:

- If the input action "Operating mode manual - local" is not parameterized: By activating the "Manual operation local - Input controlled" bit in the process image output (PIQ) or in the data table "Process image output (PIQ)" (depending on the 3RW5 communication module).
- If the input action "Operating mode manual - local" is parameterized: By activating the input action "Operating mode manual - local".

If control is with the 3RW5 HMI High Feature or with the local interface on the 3RW5 HMI High Feature (higher priority), you must actively give back control beforehand. The digital inputs can then fetch control.

Giving back control

"Automatic" mode receives control as follows:

- If the input action "Operating mode manual - local" is not parameterized: By deactivating the "Manual operation local - Input controlled" bit in the process image output (PIQ) or in the data table "Process image output (PIQ)" (depending on the 3RW5 communication module)
- If the input action "Operating mode manual - local" is parameterized: By deactivating the input action "Operating mode manual - local".

Withdrawal of control by other control sources

Control is withdrawn from the digital inputs as follows:

- Command in SIRIUS Soft Starter ES (TIA Portal) Premium / Professional (fieldbus)
Brief overview: Window "Task Card" > Tab "Online Tools" > "SIRIUS Control Panel > Master Control > Get Control"

Note

Fetching master control from "Automatic operation - Input controlled" mode

The "Automatic operation - Input controlled" mode is possible for the following 3RW5 soft starters:

- 3RW55 soft starter from firmware version V2.1
- 3RW55 Failsafe soft starter with firmware version higher than V1.0.0

-
- Command in the web server
Web page "Control Panel" > "Master Control > Get Control"

Note

Fetching master control from "Automatic operation - Input controlled" mode

The "Automatic operation - Input controlled" mode is possible for the following 3RW5 soft starters:

- 3RW55 soft starter from firmware version V2.1
- 3RW55 Failsafe soft starter with firmware version higher than V1.0.0

-
- Action "LOCAL/REMOTE" on the 3RW5 HMI High Feature
 - Command in SIRIUS Soft Starter ES (TIA Portal) (local interface on the 3RW5 HMI High Feature)
Brief overview: Window "Task Card" > Tab "Online Tools" > "SIRIUS Control Panel > Master Control > Get Control"

Operating mode "Manual operation local - HMI controlled"

Fetching control

The 3RW5 HMI High Feature actively fetches control with the action "LOCAL/REMOTE" from the lower priority control source.

If control is with the local interface on the 3RW5 HMI High Feature (higher priority), you must actively give back control beforehand in SIRIUS Soft Starter ES (TIA Portal). You can then fetch control with the action "LOCAL/REMOTE".

Giving back control

The 3RW5 HMI High Feature actively gives back control with the action "LOCAL/REMOTE" either to "Automatic" mode or to the digital inputs. If no 3RW5 communication module is installed in the 3RW55 or 3RW55 Failsafe soft starter, control is given back to the digital inputs.

Withdrawal of control by other control sources

Control is fetched from the 3RW5 HMI High Feature in response to a command to this effect in SIRIUS Soft Starter ES (TIA Portal) at the local interface on the 3RW5 HMI High Feature.

Brief overview: Window "Task Card" > Tab "Online Tools" > "SIRIUS Control Panel > Master Control > Get Control"

Operating mode "Manual operation local - PC controlled"**Fetching control**

In response to a command to this effect, SIRIUS Soft Starter ES (TIA Portal) actively fetches control from any control source.

Brief overview: Window "Task Card" > Tab "Online Tools" > "SIRIUS Control Panel > Master Control > Get Control"

Giving back control

In response to a command to this effect, SIRIUS Soft Starter ES (TIA Portal) actively gives back control either to "Automatic" mode or to the digital inputs. If no 3RW5 communication module is installed in the 3RW55 or 3RW55 Failsafe soft starter, master control is given back to the digital inputs.

Brief overview: Window "Task Card" > Tab "Online Tools" > "SIRIUS Control Panel > Master Control > Release Control"

Withdrawal of control by other control sources

Control cannot be withdrawn from SIRIUS Soft Starter ES (TIA Portal) by any control source.

Additional information

You will find more information on the process images and data tables in the manual for the respective 3RW5 communication module.

Further information on the operation of SIRIUS Soft Starter ES (TIA Portal) can be found in the online help of SIRIUS Soft Starter ES (TIA Portal).

3.6 Device versions

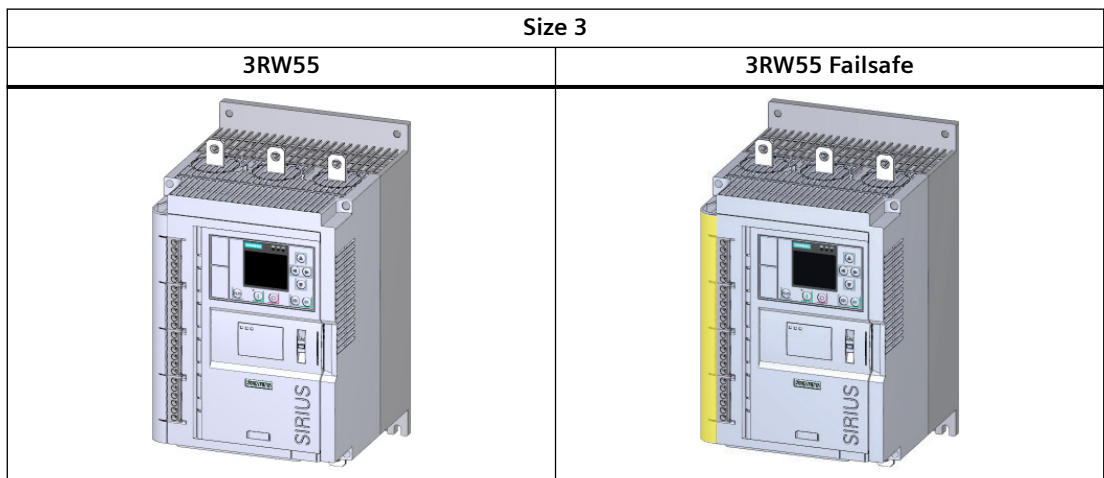
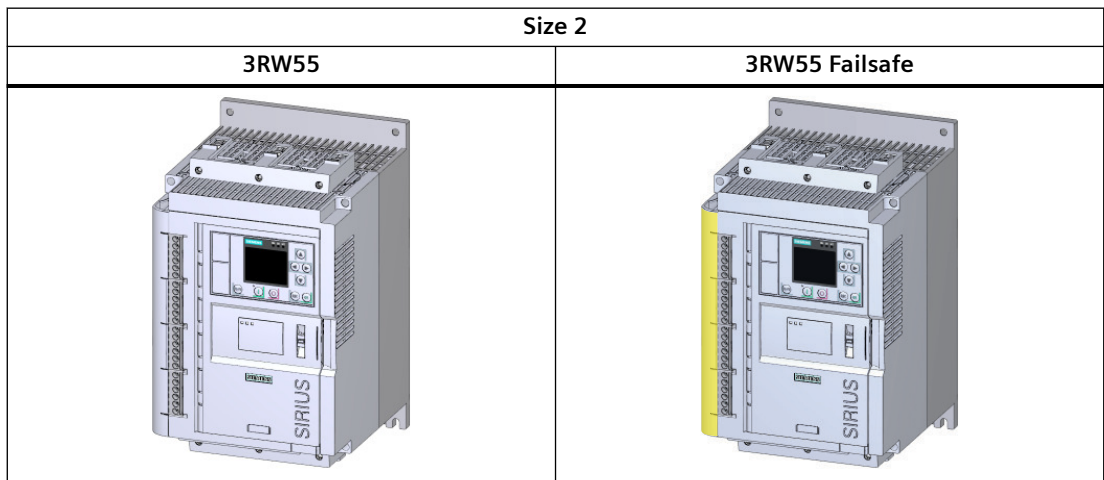
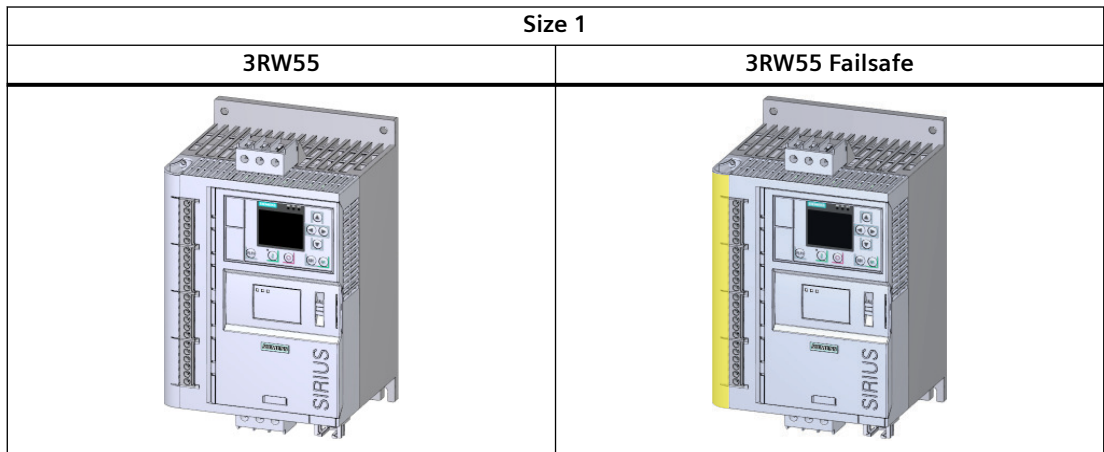

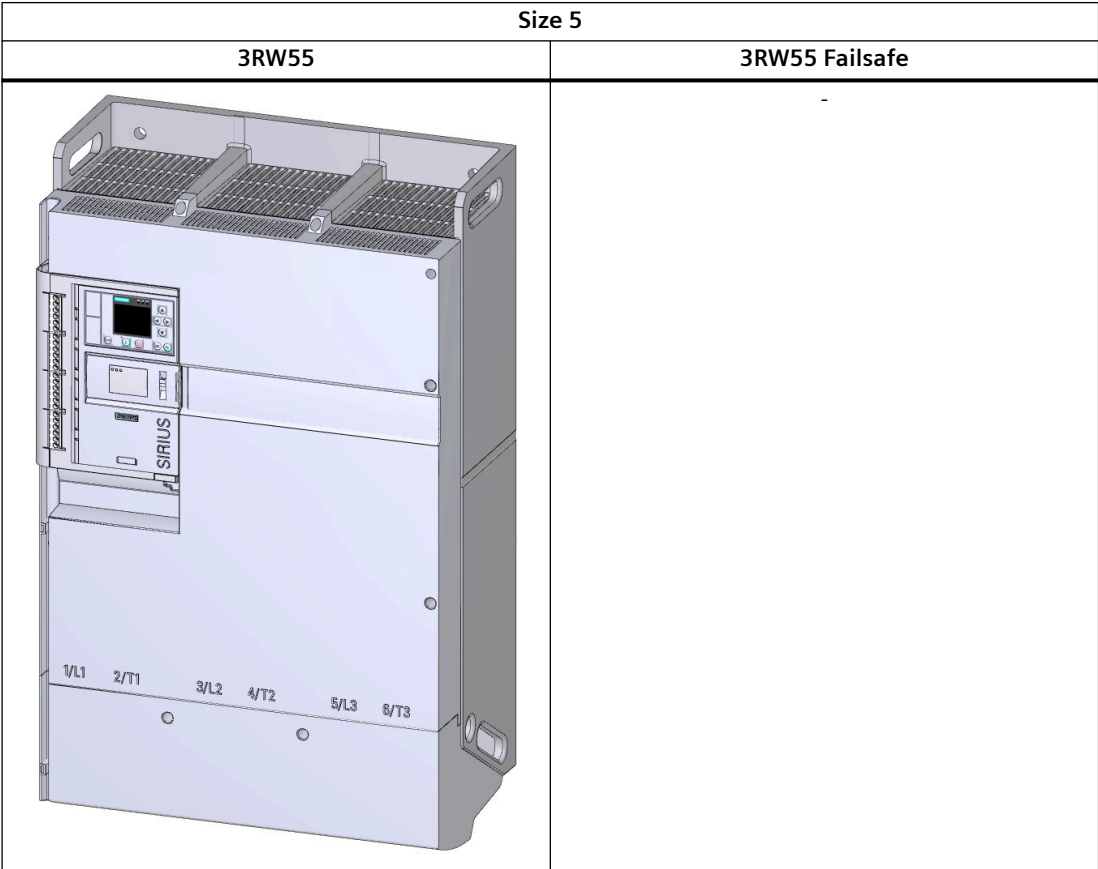
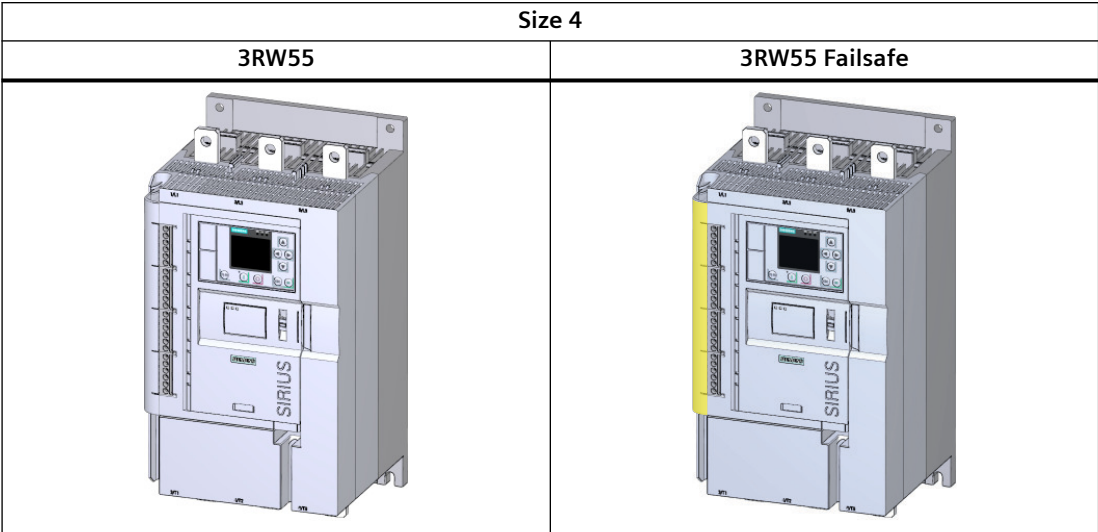

Rated operational current ranges

The stated values apply to a rated operational voltage of $U_e = 400$ V in a standard (inline) circuit.

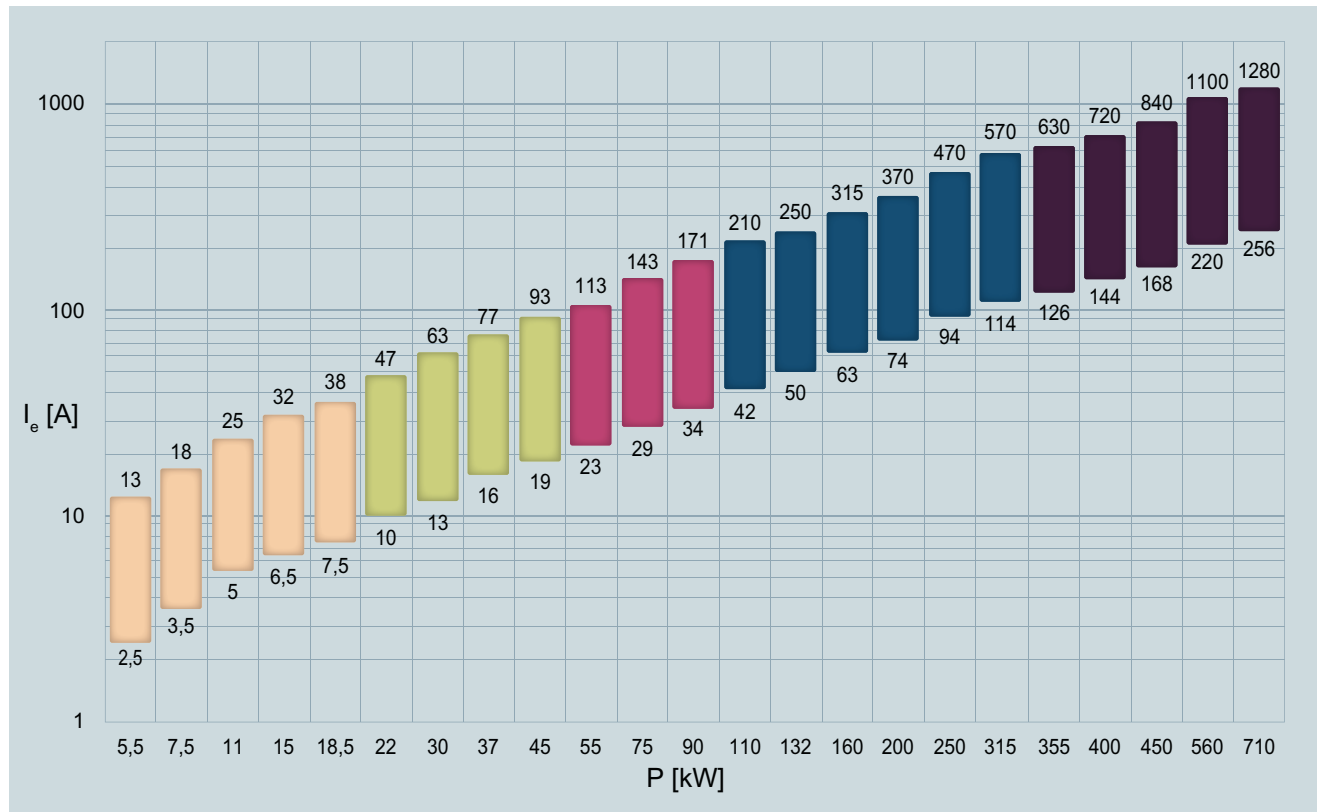

- Size 1
- Size 2
- Size 3
- Size 4
- Size 5

I_e Rated operational current
 P Rated power

3.7 Areas of application and load types

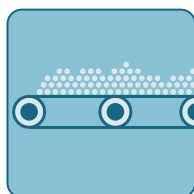

Conveyor belts

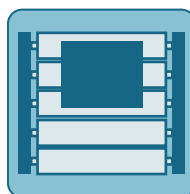

Roller conveyors



Compressors

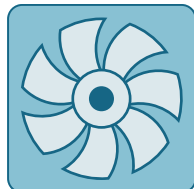

Small/large fans

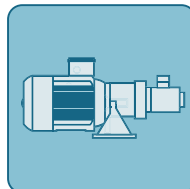

Pumps

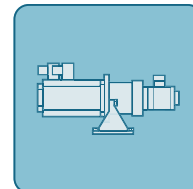

Hydraulic pumps



Agitators



Centrifuges

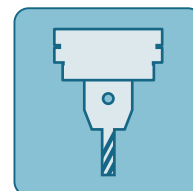

Milling machines



Mills

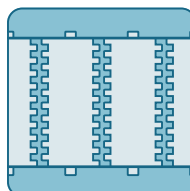

Crushers

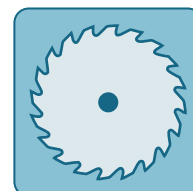

Circular saws/band saws

Starting of a motor causes a rapid change in the load current. The resulting torque impulses place severe stresses on the mechanical parts of a machine or plant. Moreover, voltage dips can occur in the power supply system which can have a negative influence on other devices:

- Flicker in lights
- Influence on computer systems
- Contactors and relays dropping out

The 3RW55 and 3RW55 Failsafe soft starters control the voltage continuously. The torque and the current are thus also increased continuously. The power supply system is safeguarded against peak loads and the drive train is protected against damage:

- Smooth starting/stopping, e.g. for conveyor belts
- No pressure surges, e.g. for pumps
- Increased service life of the pipe system, e.g. for compressors

- Reduced starting current, e.g. for agitators
- Reduced stress on gearbox and V belt, e.g. for saws

3.8 Selection of the soft starter using the Simulation Tool for Soft Starters

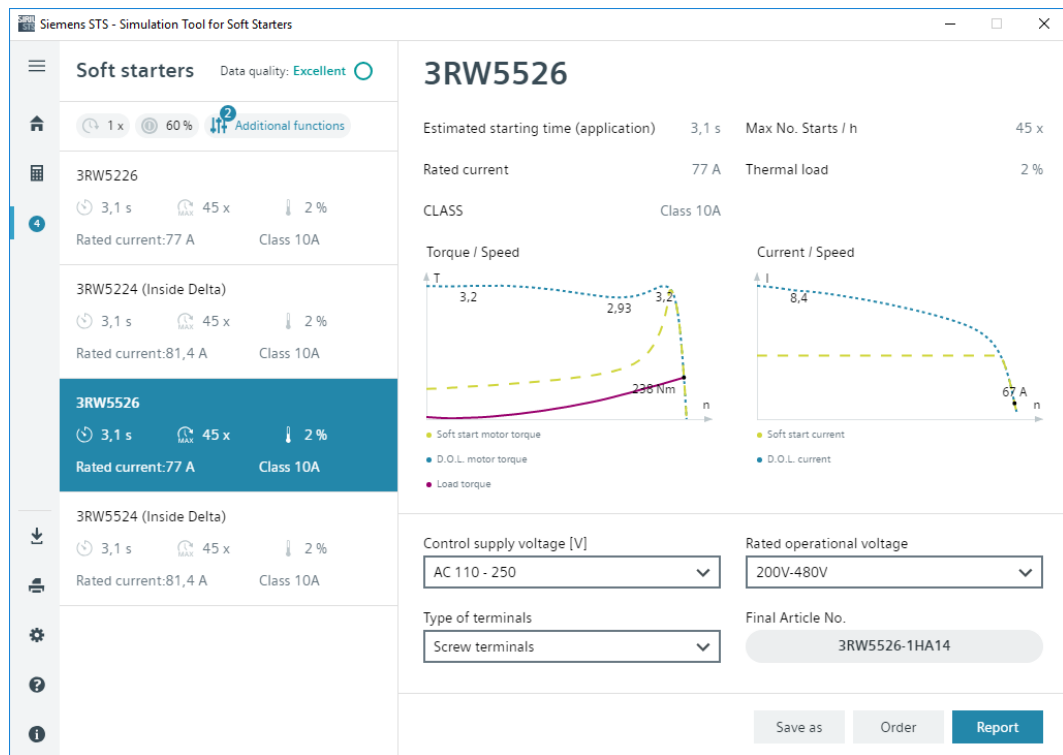

The soft starter can be configured with the STS (Simulation Tool for Soft Starters) software. The STS suggests suitable soft starters for the respective application based on the entered motor and load data and application requirements, as well as providing information on the parameterization.

You can download the Simulation Tool for Soft Starters (STS) for free on the 3RW5 topic page (<https://support.industry.siemens.com/cs/ww/en/view/109747404>).

3.9 Structure of the article number

Information on the rated operational current (derating)

Note that the 3RW55 and 3RW55 Failsafe soft starters are approved for operation in a temperature range of -25 °C to +60 °C. Consider the derating of the rated operational current at ambient temperatures higher than 40 °C. You will find further information on derating in the Technical specifications (Page 287) in section "Power electronics" or in Catalog IC 10 (<https://support.industry.siemens.com/cs/ww/en/view/109747945>).

3RW55 soft starter

Digit of the article number	1st-4th	5th	6th	7th	8th	9th	10th	11th	12th
SIRIUS 3RW soft starter	3RW5	5				H	A		x ^{***1)}
Size of the 3RW55 soft starter			x ^{*1)}						
Rated operational current I _e of the 3RW55 soft starter				x ^{**1)}					
Connection system	<ul style="list-style-type: none"> Applies to sizes 1 / 2 Main circuit: Screw terminals Control circuit: Screw terminals 				1				
	<ul style="list-style-type: none"> Applies to sizes 3 / 4 / 5 Main circuit: Bus connection Control circuit: Spring-loaded terminals 				2				
	<ul style="list-style-type: none"> Applies to sizes 1 / 2 Main circuit: Screw terminals Control circuit: Spring-loaded terminals 				3				
	<ul style="list-style-type: none"> Applies to sizes 3 / 4 / 5 Main circuit: Bus connection Control circuit: Screw terminals 				6				
Rated control supply voltage U _s ²⁾					24 V AC/DC		0		
					110 - 250 V AC		1		
Rated operational voltage U _e					200 - 480 V AC		4		
					200 - 600 V AC		5		
					200 - 690 V AC		6		

1) Explanation in the following table.

2) When rating the control supply voltage, pay attention to the maximum starting current when closing the bypass contacts; details can be found in the technical data.

The following table shows the size and rated operational current I_e for U_e = 400 V and TU = 40 °C in a standard (inline) circuit:

Size	Rated operational current I _e of the 3RW55 soft starter	Rated operating power P _e of the 3RW55 soft starter	x [*]	x ^{**}	x ^{***}
Size 1	I _e = 13 A	P _e = 5.5 kW	1	3	4 / 5
	I _e = 18 A	P _e = 7.5 kW	1	4	
	I _e = 25 A	P _e = 11 kW	1	5	
	I _e = 32 A	P _e = 15 kW	1	6	
	I _e = 38 A	P _e = 18.5 kW	1	7	

Description

3.9 Structure of the article number

Size 2	$I_e = 25 \text{ A}$	$P_e = 11 \text{ kW}$	2	1	6
	$I_e = 47 \text{ A}$	$P_e = 22 \text{ kW}$	2	4	4 / 6
	$I_e = 63 \text{ A}$	$P_e = 30 \text{ kW}$	2	5	
	$I_e = 77 \text{ A}$	$P_e = 37 \text{ kW}$	2	6	
	$I_e = 93 \text{ A}$	$P_e = 45 \text{ kW}$	2	7	
Size 3	$I_e = 113 \text{ A}$	$P_e = 55 \text{ kW}$	3	4	
	$I_e = 143 \text{ A}$	$P_e = 75 \text{ kW}$	3	5	
	$I_e = 171 \text{ A}$	$P_e = 90 \text{ kW}$	3	6	
Size 4	$I_e = 210 \text{ A}$	$P_e = 110 \text{ kW}$	4	3	
	$I_e = 250 \text{ A}$	$P_e = 132 \text{ kW}$	4	4	
	$I_e = 315 \text{ A}$	$P_e = 160 \text{ kW}$	4	5	
	$I_e = 370 \text{ A}$	$P_e = 200 \text{ kW}$	4	6	
	$I_e = 470 \text{ A}$	$P_e = 250 \text{ kW}$	4	7	
	$I_e = 570 \text{ A}$	$P_e = 315 \text{ kW}$	4	8	
Size 5	$I_e = 630 \text{ A}$	$P_e = 355 \text{ kW}$	5	2	
	$I_e = 720 \text{ A}$	$P_e = 400 \text{ kW}$	5	3	
	$I_e = 840 \text{ A}$	$P_e = 450 \text{ kW}$	5	4	
	$I_e = 1\,100 \text{ A}$	$P_e = 560 \text{ kW}$	5	6	
	$I_e = 1\,280 \text{ A}$	$P_e = 710 \text{ kW}$	5	8	

3RW55 Failsafe soft starter

Digit of the article number	1st-4th	5th	6th	7th	8th	9th	10th	11th	12th
SIRIUS 3RW soft starter	3RW5	5				H	F		
Size of the 3RW55 Failsafe soft starter			x ^{*1)}						
Rated operational current I _e of the 3RW55 Failsafe soft starter				x ^{**1)}					
Connection system	<ul style="list-style-type: none"> Applies to sizes 1/2 Main circuit: Screw terminals Control circuit: Screw terminals 				1				
	<ul style="list-style-type: none"> Applies to sizes 3/4 Main circuit: Bus connection Control circuit: Spring-loaded terminals 				2				
	<ul style="list-style-type: none"> Applies to sizes 1/2 Main circuit: Screw terminals Control circuit: Spring-loaded terminals 				3				
	<ul style="list-style-type: none"> Applies to sizes 3/4 Main circuit: Bus connection Control circuit: Screw terminals 				6				
Rated control supply voltage U _s ²⁾					24 V AC/DC		0		
					110 - 250 V AC		1		
Rated operational voltage U _e					200 - 480 V AC				4

1) Explanation in the following table.

2) When rating the control supply voltage, pay attention to the maximum starting current when closing the bypass contacts; details can be found in the technical data.

The following table shows the size and rated operational current I_e for U_e = 400 V and TU = 40 °C in a standard (inline) circuit:

Size	Rated operational current I _e of the 3RW55 Failsafe soft starter	Rated operating power P _e of the 3RW55 Failsafe soft starter	x [*]	x ^{**}
Size 1	I _e = 13 A	P _e = 5.5 kW	1	3
	I _e = 18 A	P _e = 7.5 kW	1	4
	I _e = 25 A	P _e = 11 kW	1	5
	I _e = 32 A	P _e = 15 kW	1	6
	I _e = 38 A	P _e = 18.5 kW	1	7
Size 2	I _e = 47 A	P _e = 22 kW	2	4
	I _e = 63 A	P _e = 30 kW	2	5
	I _e = 77 A	P _e = 37 kW	2	6
	I _e = 93 A	P _e = 45 kW	2	7
Size 3	I _e = 113 A	P _e = 55 kW	3	4
	I _e = 143 A	P _e = 75 kW	3	5
	I _e = 171 A	P _e = 90 kW	3	6

Description

3.9 Structure of the article number

Size 4	$I_e = 210 \text{ A}$	$P_e = 110 \text{ kW}$	4	3
	$I_e = 250 \text{ A}$	$P_e = 132 \text{ kW}$	4	4
	$I_e = 315 \text{ A}$	$P_e = 160 \text{ kW}$	4	5
	$I_e = 370 \text{ A}$	$P_e = 200 \text{ kW}$	4	6
	$I_e = 470 \text{ A}$	$P_e = 250 \text{ kW}$	4	7
	$I_e = 570 \text{ A}$	$P_e = 315 \text{ kW}$	4	8

3.10 Accessories

3.10.1 Accessories for 3RW55 and 3RW55 Failsafe soft starters

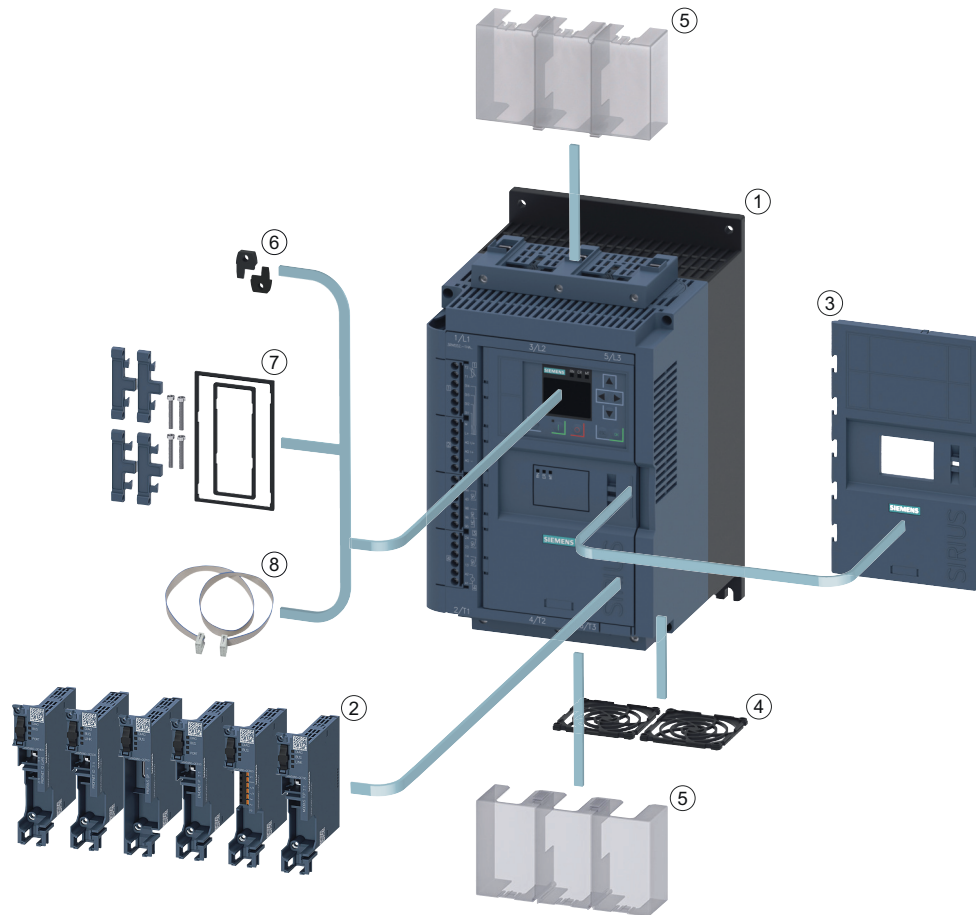

① 3RW55 or 3RW55 Failsafe soft starter (illustration similar)

- ② 3RW5 communication modules:
 - PROFIBUS (3RW5980-0CP00)
(from firmware version V1.0.1)
 - PROFINET standard (3RW5980-0CS00)
(from firmware version V1.0.1)
 - PROFINET High Feature (3RW5950-0CH00)
(from firmware version V1.0 for 3RW55 soft starters from firmware version V2.0)
(from firmware version V1.1 for 3RW55 Failsafe soft starters)
 - Modbus TCP (3RW5980-0CT00)
(from firmware version V1.0 for 3RW55 soft starters)
(from firmware version V1.1 for 3RW55 Failsafe soft starters)
 - Modbus RTU (3RW5980-0CR00)
(from firmware version V1.0 for 3RW55 soft starters from firmware version V2.0)
(from firmware version V1.0 for 3RW55 Failsafe soft starters)
 - EtherNet/IP (3RW5980-0CE00)
(from firmware version V1.0 for 3RW55 soft starters from firmware version V2.0)
(from firmware version V1.0 for 3RW55 Failsafe soft starters)
- ③ Hinged cover (3RW5950-0GL20)
- ④ Fan cover:
 - Sizes 1, 2 and 3 (3RW5983-0FC00)
 - Size 4 (3RW5984-0FC00)
 - Size 5 (3RW5985-0FC00)
- ⑤ Terminal cover, top and bottom:
 - Sizes 2 and 3 (3RW5983-0TC20)
 - Size 4 (3RW5984-0TC20)
- ⑥ Push-in lugs for wall mounting (3ZY1311-0AA00)
- ⑦ IP65 door mounting kit (3RW5980-0HD00)
- ⑧ HMI connecting cable:
 - 0.1 m (3UF7931-0AA00-0)
 - 0.5 m (3UF7932-0BA00-0)
 - 1 m (3UF7937-0BA00-0)
 - 2.5 m (3UF7933-0BA00-0)
 - 5 m (3RW5980-0HC60)

Note the information in chapter Firmware update (Page 24).

3.10.2 3RW5 communication module

The following 3RW5 communication modules are available for integration of the 3RW55 and 3RW55 Failsafe soft starters in fieldbus systems:

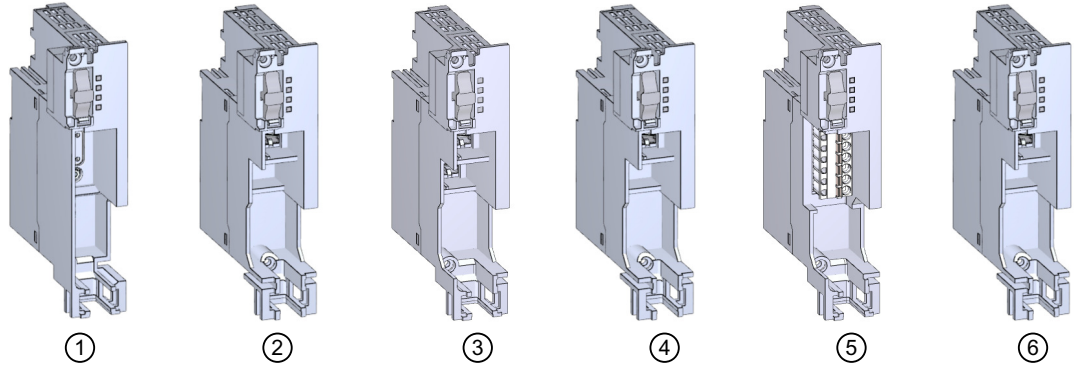

- ① 3RW5 PROFIBUS communication module
(from firmware version V1.0.1)
- ② 3RW5 PROFINET standard communication module
(from firmware version V1.0.1)
- ③ 3RW5 PROFINET High Feature communication module
(from firmware version V1.0 for 3RW55 soft starters from firmware version V2.0)
(from firmware version V1.1 for 3RW55 Failsafe soft starters)
- ④ 3RW5 Modbus TCP communication module
(from firmware version V1.0 for 3RW55 soft starters)
(from firmware version V1.1 for 3RW55 Failsafe soft starters)
- ⑤ 3RW5 Modbus RTU communication module
(from firmware version V1.0 for 3RW55 soft starters from firmware version V2.0)
(from firmware version V1.0 for 3RW55 Failsafe soft starters)
- ⑥ 3RW5 EtherNet/IP communication module
(from firmware version V1.0 for 3RW55 soft starters from firmware version V2.0)
(from firmware version V1.0 for 3RW55 Failsafe soft starters)

Note the information in chapter Firmware update (Page 24).

Integration into the automation software

The 3RW55 and 3RW55 Failsafe soft starters can be integrated in an automation software, e.g. STEP 7 (TIA Portal) via GSD or GSDML/HSP.

You will find further information on operation of the 3RW5 communication module in the manual (Page 11) for the respective 3RW5 communication module.

3.10.3 SIRIUS Soft Starter ES (TIA Portal)

SIRIUS Soft Starter ES (TIA Portal) as of V15 Update 2 is the central software for configuring, commissioning, operation, and diagnostics of 3RW5 soft starters. Depending on the firmware, 3RW55 soft starters are supported as of V15 Update 2, 3RW55 Failsafe soft starters as of V15.1 Update 2.

3.10 Accessories

You connect your PC or programming device to the 3RW55 or 3RW55 Failsafe soft starter via the local interface on the 3RW5 HMI High Feature. With the Premium or Professional license, you can also connect your PC or your programming device from a central point to the 3RW55 or 3RW55 Failsafe soft starter via a 3RW5 PROFINET or PROFIBUS communication module (accessory).

By displaying all operating data, service data and diagnostic data, SIRIUS Soft Starter ES (TIA Portal) provides reliable information, which helps you to avoid faults, or quickly locate and eliminate faults if they occur.

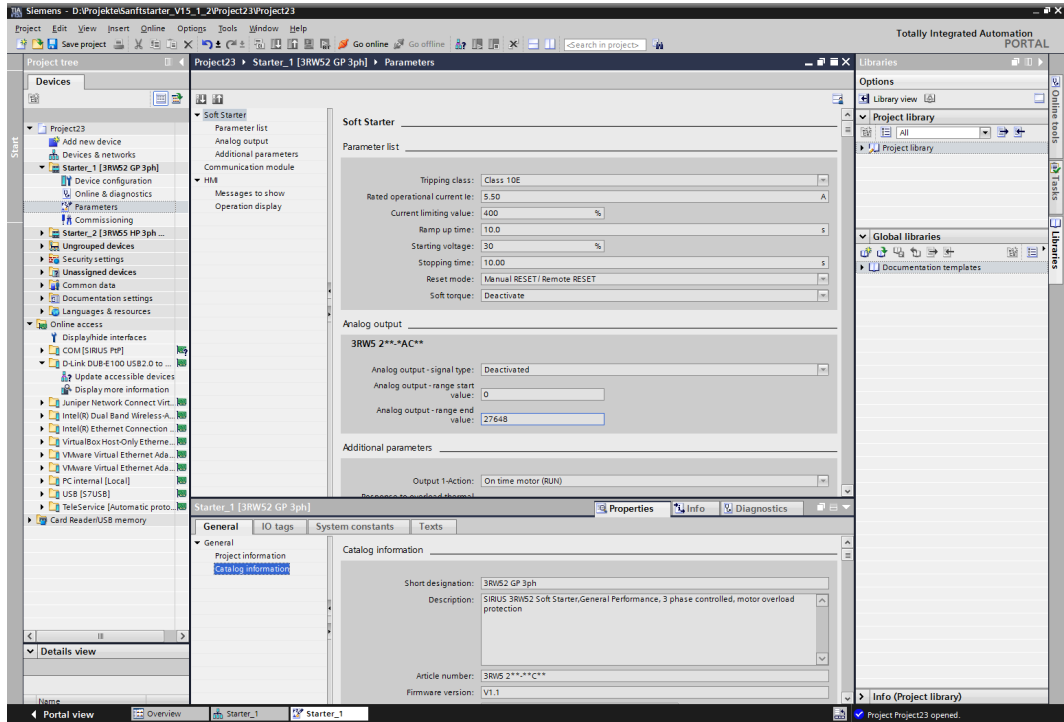

Illustration similar

Download

You can download SIRIUS Soft Starter ES (TIA Portal) via the following link (<https://support.industry.siemens.com/cs/ww/en/ps/24231/dl>).

Available versions for V15 and V15.1

Supported functions (V15.1)	SIRIUS Soft Starter ES (TIA Portal)		
	Basic	Standard	Premium
Access via local interface on the 3RW5 HMI High Feature	X	X	X
Parameter setting	X	X	X
Operator control	X	X	X
Diagnosis	X	X	X
Expert list	-	X	X

Supported functions (V15.1)	SIRIUS Soft Starter ES (TIA Portal)		
	Basic	Standard	Premium
Parameter comparison	-	X	X
Service data (maximum pointer, statistic data)	-	X	X
Trace	-	X	X
Access via PROFIBUS or PROFINET	-	-	X
Teleservice via MPI	-	-	X
Routing	-	-	X
Bulk engineering (group function)	-	-	X

Versions available as of V16

Supported functions	SIRIUS Soft Starter ES (TIA Portal)	
	Basic	Professional ¹⁾
Access via local interface on the 3RW5 HMI High Feature	X	X
Parameter setting	X	X
Operator control	X	X
Diagnosis	X	X
Expert list	-	X
Parameter comparison	-	X
Service data (maximum pointer, statistic data)	-	X
Trace	-	X
Access via PROFIBUS or PROFINET	-	X
Teleservice via MPI	-	X
Routing	-	X
Bulk engineering (group function)	-	X

¹⁾ The "Professional" variant corresponds to the "Premium" version of V15.1

Additional information

You will find further information on SIRIUS Soft Starter ES (TIA Portal) and necessary versions and updates in Catalog IC 10 (<https://support.industry.siemens.com/cs/ww/en/view/109747945>) and on the 3RW5 topic page (<https://support.industry.siemens.com/cs/ww/en/view/109747404>).

Description

3.10 Accessories

Mounting and dismantling

4.1 Mounting 3RW55 and 3RW55 Failsafe soft starters

Procedure

1. Optionally mount the fan cover (Page 57).
2. Mount the 3RW55 or 3RW55 Failsafe soft starter on a level surface (Page 58). Ensure that the permissible temperature range and the necessary clearances are complied with.
Technical specifications (Page 287)
3. You also have the option of mounting the 3RW5 communication module (accessory). You will find further information in the manual for the 3RW5 communication module in question.

Result

You have mounted the 3RW55 or 3RW55 Failsafe soft starter and can now connect it.

You can remove the 3RW5 HMI High Feature and install it in a control cabinet door, for example. You can proceed as follows:

- Removing the 3RW5 HMI High Feature (Page 62)
- Installing the 3RW5 HMI High Feature in the control cabinet door (Page 66)
- Installing the High Feature 3RW5 HMI on a flat surface (Page 64)

4.2 Mounting the fan cover

Requirements

- Screwdriver T20
- Fan cover (accessory) suitable for the size

Size	Article number of the 3RW55 or 3RW55 Failsafe soft starter	Article number of the fan cover	Number of required fan covers
Size 1	3RW551.-.....	3RW5983-OFC00	1
Size 2	3RW552.-.....		2
Size 3	3RW553.-.....		2
Size 4	3RW554.-.....	3RW5984-OFC00	1
Size 5	3RW555.-.....	3RW5985-OFC00	3

Procedure

NOTICE

Material damage due to mechanical load.

Avoid a mechanical load on the fan hub when mounting the fan cover.

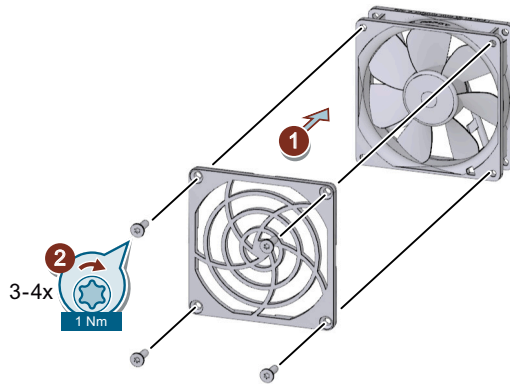

- Place the fan cover on the fan ① and fasten the fan cover ②.
 - Size 1: You require 1 fan cover and 4 of the screws packed with the product.
 - Sizes 2 and 3: You require 2 fan covers. Due to the design, 3 screws packed with the product are sufficient in each case.
 - Size 4: You require 1 fan cover and 4 of the screws packed with the product.
 - Size 5: You require 3 fan covers and, for each of these, 4 of the screws packed with the product.

Result

The fan cover provides enhanced touch protection and prevents the fan from being blocked by foreign objects.

4.3 Mount the 3RW55 and 3RW55 Failsafe soft starters on a level surface

Requirements

- Comply with the mounting positions and ambient conditions stated on the data sheet.
- Comply with the minimum clearances indicated in the following diagram.
- Level surface, e.g. sufficiently strong mounting plate
- 4 properly executed drill holes with thread or plug on the level surface.

4.3 Mount the 3RW55 and 3RW55 Failsafe soft starters on a level surface

- 4 screws of suitable size and with regular thread for insertion into the selected mounting plate or wall.
Use an additional 4 washers if the head of the screw is smaller than the specified diameter.
- Screwdriver (depending on the drive of the screws)
- If necessary, use shims and snap rings.
- For size 5, mounting with a crane (optional): Crane load attachment with 4 hooks

Size	Article No.	Screws	Tightening torque
Size 1	3RW551.-.....	M6	5 Nm
Size 2	3RW552.-.....		
Size 3	3RW553.-.....		
Size 4	3RW554.-.....	M8	8 Nm
Size 5	3RW555.-.....	M12	35 Nm

The following diagram shows the minimum clearances for the 3RW55 and 3RW55 Failsafe soft starters:

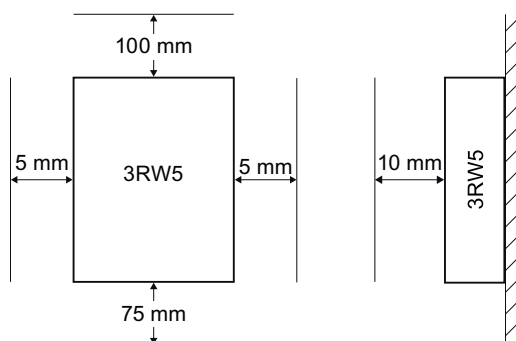

Procedure for sizes 1 to 4

<p>⚠ CAUTION</p> <p>Heavy device</p> <p>Device can cause injury if it falls.</p> <p>Always ask a second person to help you transport, install and remove a heavy device. Use suitable lifting equipment and wear personnel protective equipment.</p>
--

4.3 Mount the 3RW55 and 3RW55 Failsafe soft starters on a level surface

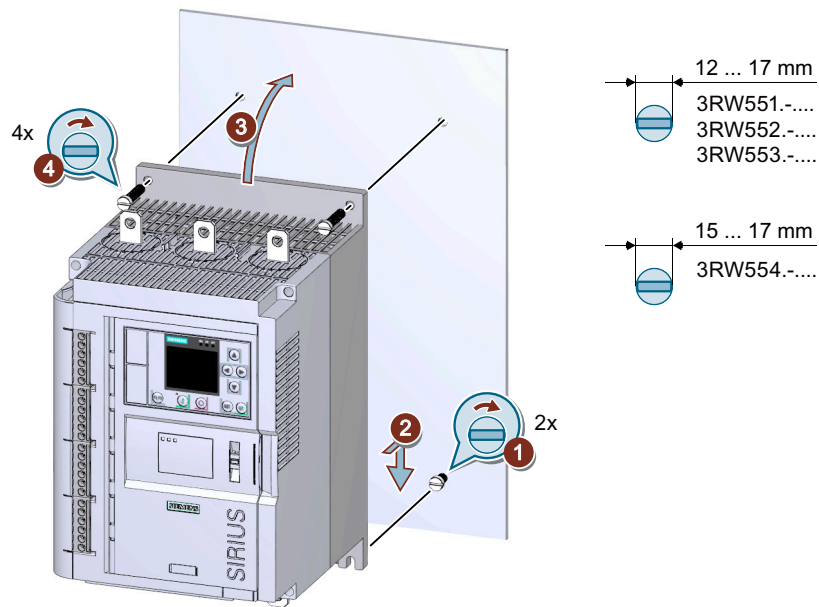

Illustration similar

- Screw the lower 2 screws into the mounting plate ①. Ensure that both screws protrude by at least 1.5 cm (at least 2 cm for size 4) and then place the 3RW55 or 3RW55 Failsafe soft starter onto the 2 lower screws ② from above.
- Tilt the 3RW55 or 3RW55 Failsafe soft starter up so that it is resting level against the mounting plate ③ and tighten all 4 screws with the specified torque ④.

Procedure for size 5

⚠ CAUTION
Heavy device
Device can cause injury if it falls.
Always ask a second person to help you transport, install and remove a heavy device. Use suitable lifting equipment and wear personnel protective equipment.

4.3 Mount the 3RW55 and 3RW55 Failsafe soft starters on a level surface

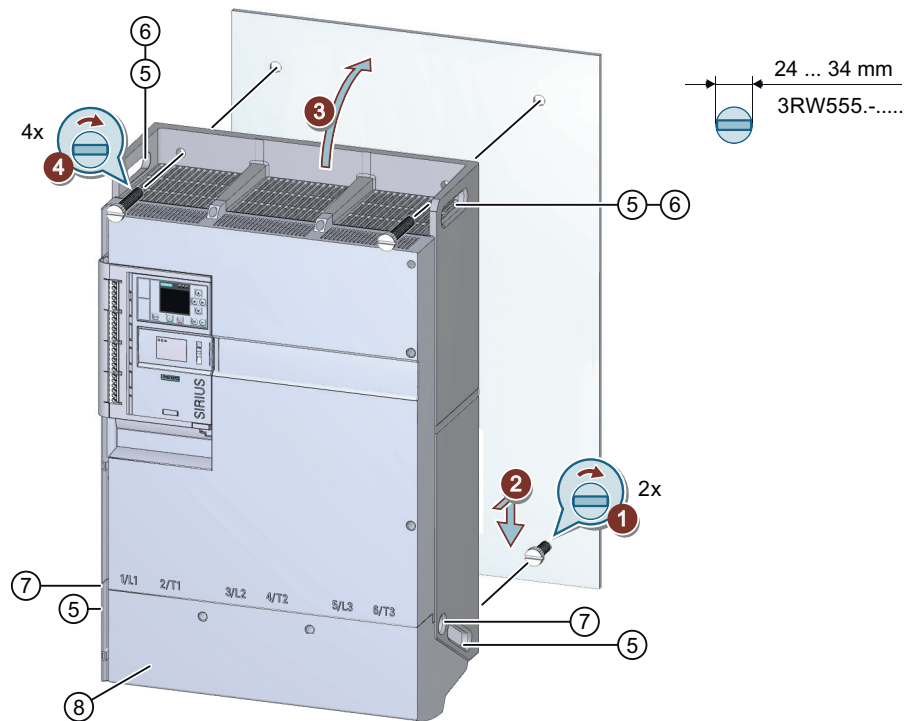

Illustration similar

Installation without a crane

- Remove the terminal cover (8) that is plugged in on the top and mount it after the 3RW55 soft starter has been mounted completely (Page 78).
- Screw the lower 2 screws into the mounting plate (1).
- Ensure that both screws protrude at least 4 cm and then place the 3RW55 soft starter onto the 2 lower screws (2) from above using the handles (5) provided (2 people).
- Tilt the 3RW55 soft starter up so that it is resting level against the mounting plate (3) and tighten all 4 screws with the specified torque (4).

Installation with a crane

- Remove the terminal cover (8) that is plugged in on the top and mount it after the 3RW55 soft starter has been mounted completely (Page 78).
- Screw the lower 2 screws into the mounting plate (1). Make sure that both screws are protruding at least 4 cm.
- Use a crane load attachment with 4 hooks to lift the 3RW55 soft starter out of the packaging. Attach the hooks of the crane load attachment to the cutouts (6) and (7). Lift the 3RW55 soft starter horizontally out of the packaging and set the 3RW55 soft starter down on a horizontal surface.
- Use a crane load attachment with 2 hooks to mount the 3RW55 soft starter. Attach the hooks of the crane load attachment to the cutouts (6).

4.4 Installing, mounting and removing the 3RW5 HMI High Feature

- Place the 3RW55 soft starter onto the 2 lower screws ② from above with the crane.
- Tilt the 3RW55 soft starter up so that it is resting level against the mounting plate ③ and tighten all 4 screws with the specified torque ④.

Result

You have mounted the 3RW55 or 3RW55 Failsafe soft starter on a level surface and can now connect (Page 76) it.

4.4 Installing, mounting and removing the 3RW5 HMI High Feature

4.4.1 Removing the 3RW5 HMI High Feature

Requirements

- Flat-bladed screwdriver

Procedure

NOTICE
Damage to sealing surfaces
Make sure that the sealing surfaces are not damaged by the screwdriver.

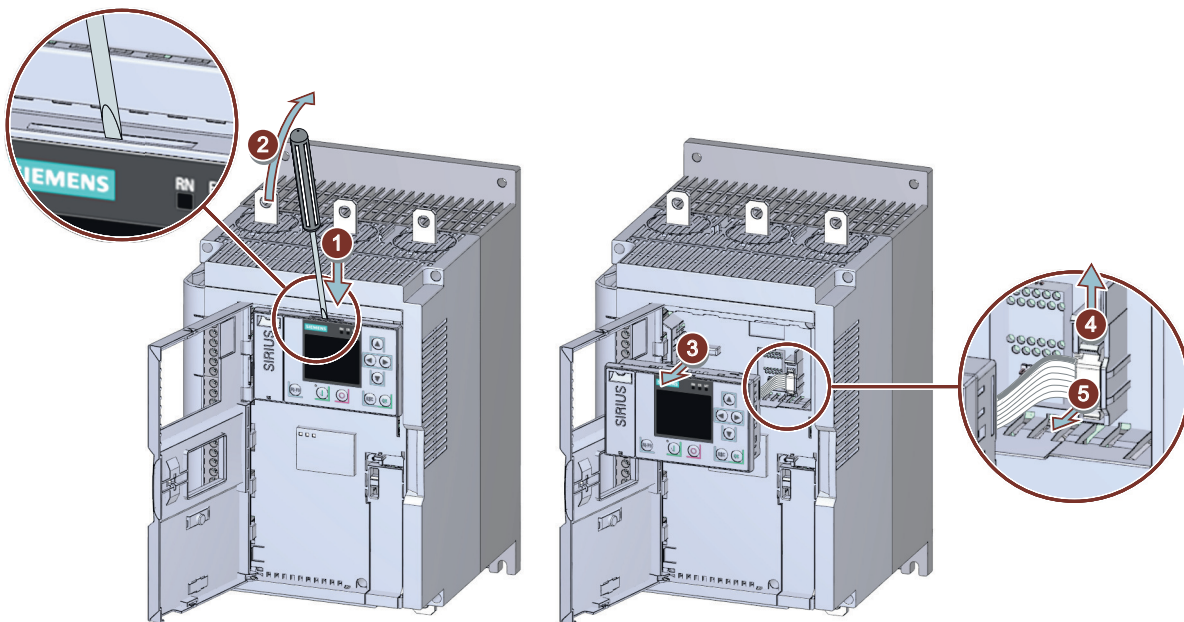

Illustration similar

- Release the 3RW5 HMI High Feature using a flat-bladed screwdriver in the groove provided ① / ②.
- Pull the 3RW5 HMI High Feature far enough out of the 3RW55 or 3RW55 Failsafe soft starter ③ to gain access to the HMI connecting cable.
- Unfasten the retaining elements of the HMI connecting cable ④ and pull the HMI connecting cable out of the 3RW55 or 3RW55 Failsafe soft starter ⑤.

Result

You have removed the 3RW5 HMI High Feature. You can install the 3RW5 HMI High Feature on a level surface (Page 64) or in a cabinet door (Page 66) or you can install a new 3RW5 HMI High Feature (Page 63).

4.4.2 Installing the 3RW5 HMI High Feature in the 3RW55 or 3RW55 Failsafe soft starter

Requirements

- 3RW5 HMI High Feature
- HMI connecting cable, 0.1 m (accessories)

Procedure



NOTICE

Damage caused by electrostatic charge

Note the information in chapter ESD Guidelines (Page 15).

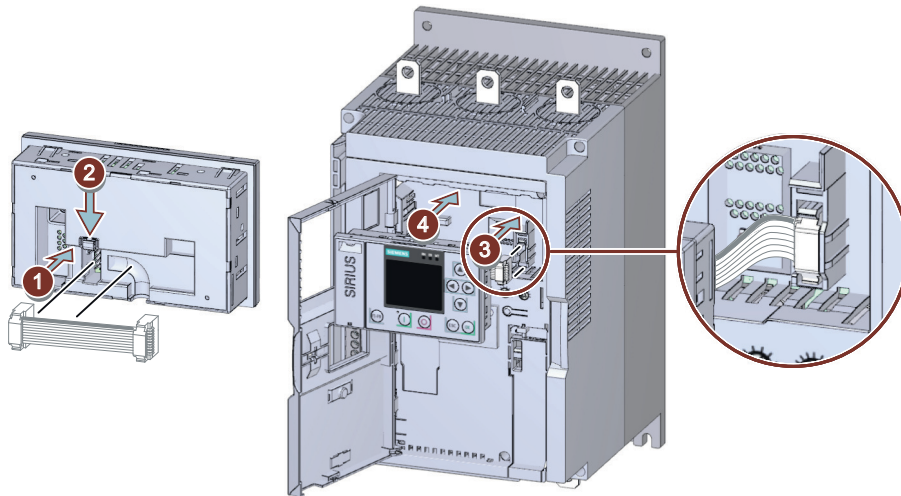

Illustration similar

- Observe the coding of the plug and socket ① / ③.
- Lock the connector in the socket ②.
- Observe the cable routing:
 - ① Cable routing to the right
 - ③ Cable routing to the left

Result

You have installed the 3RW5 HMI High Feature in the 3RW55 or 3RW55 Failsafe soft starter and can commission (Page 129) it.

4.4.3 Installing the High Feature 3RW5 HMI on a flat surface

Requirements

- Note the mounting positions, minimum clearances and ambient conditions stated on the data sheet.
- Removed 3RW5 HMI High Feature (Page 62)
- Level surface, e.g. sufficiently strong mounting plate

- 2 properly executed drill holes with thread or plugs on the level surface. Refer to the drilling pattern (Page 289).
- 2 head screws M4 x 12 DIN ISO 7045 to fit the drill-holes
- Screwdriver (depending on the drive of the screws)
- 2 push-in lugs (accessories) for wall mounting
- HMI connecting cable (accessory) of suitable length connected to the 3RW55 or 3RW55 Failsafe soft starter

Procedure

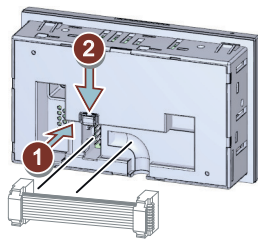

- Observe the coding of the plug and socket ①.
- Lock the connector in the socket ②.
- The HMI connecting cable in the cable duct of the 3RW5 HMI High Feature may only be routed downward.
Make sure that you install the cable in accordance with EMC requirements. For example, install data cables separately from the motor cable. Connect both sides of shielded cables over a large surface area.

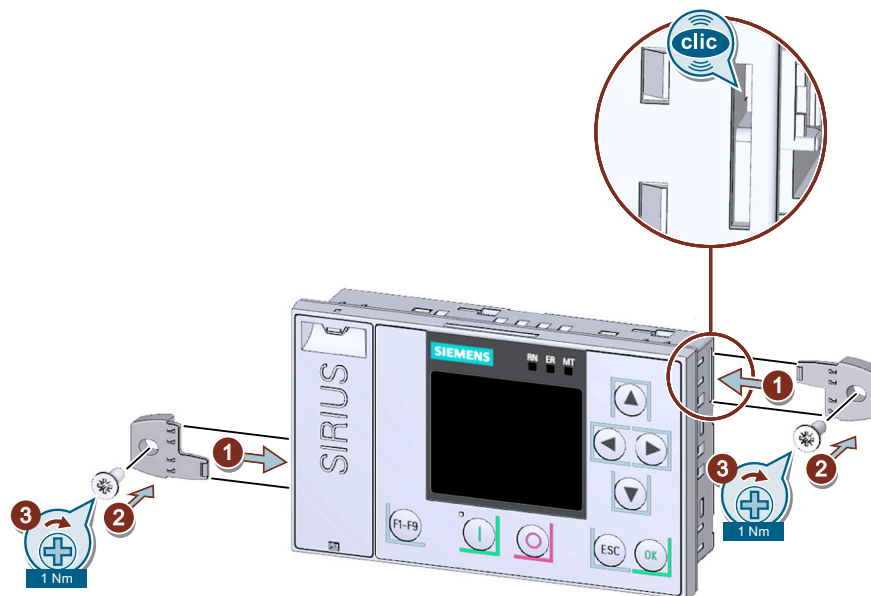

- Insert the push-in lugs into each side of the enclosure until you hear them engage ① and fix the 3RW5 HMI High Feature on the wall ② / ③.

Result

You have installed the 3RW5 HMI High Feature on a level surface and can commission (Page 129) it.

4.4.4 Installing the 3RW5 HMI High Feature in the control cabinet door

Requirements

- Note the mounting positions, minimum clearances and ambient conditions stated on the data sheet.
- Removed 3RW5 HMI High Feature (Page 62)
- HMI connecting cable (accessory) of suitable length connected to the 3RW55 or 3RW55 Failsafe soft starter
- Cutout of suitable size in the control cabinet door
- Depth of the 3RW5 HMI High Feature:
 - Total depth: 32 mm
 - Recessed depth: 26 mm
- Permissible wall thickness of the control cabinet door:
 - Without IP65 door mounting kit: 1.5 to 3.0 mm
 - With IP65 door mounting kit: 1.0 to 7.0 mm

For using door mounting kit IP65:

- IP65 door mounting kit (accessory)
The fixing brackets with marking "002" are intended for a 3RW5 HMI High Feature.
- Screwdriver PZ2

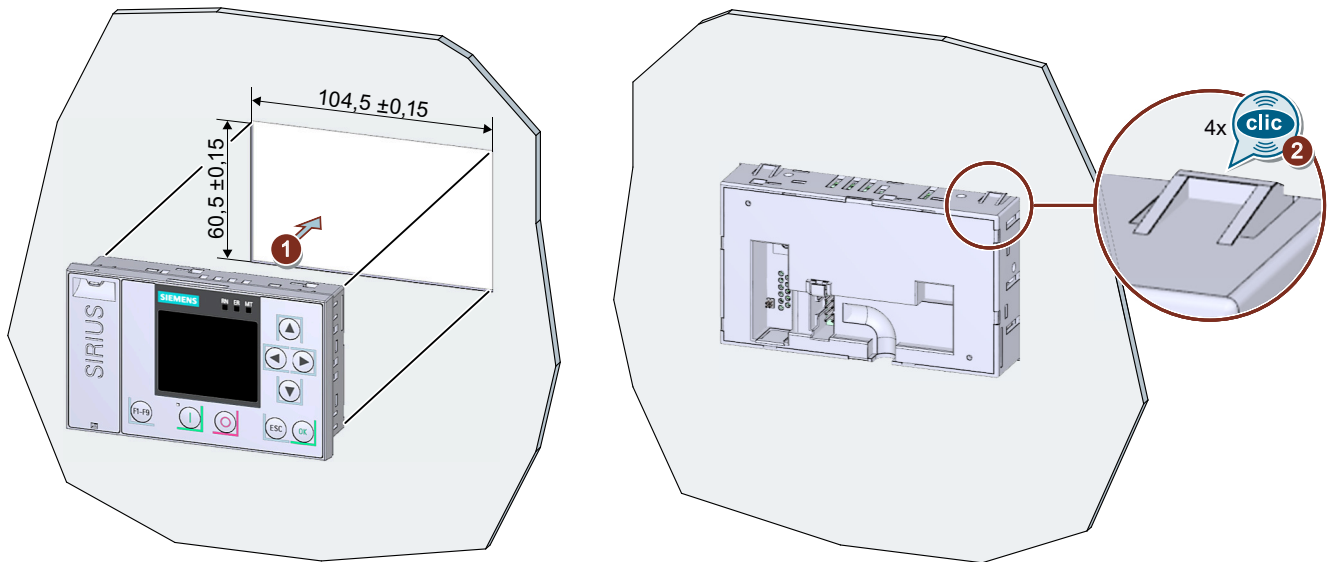
Procedure without IP65 door mounting kit

Place the 3RW5 HMI High Feature in the cutout of the control cabinet door ①. Ensure that the 3RW5 HMI High Feature engages audibly in the 4 fixtures ②.

Procedure with IP65 door mounting kit

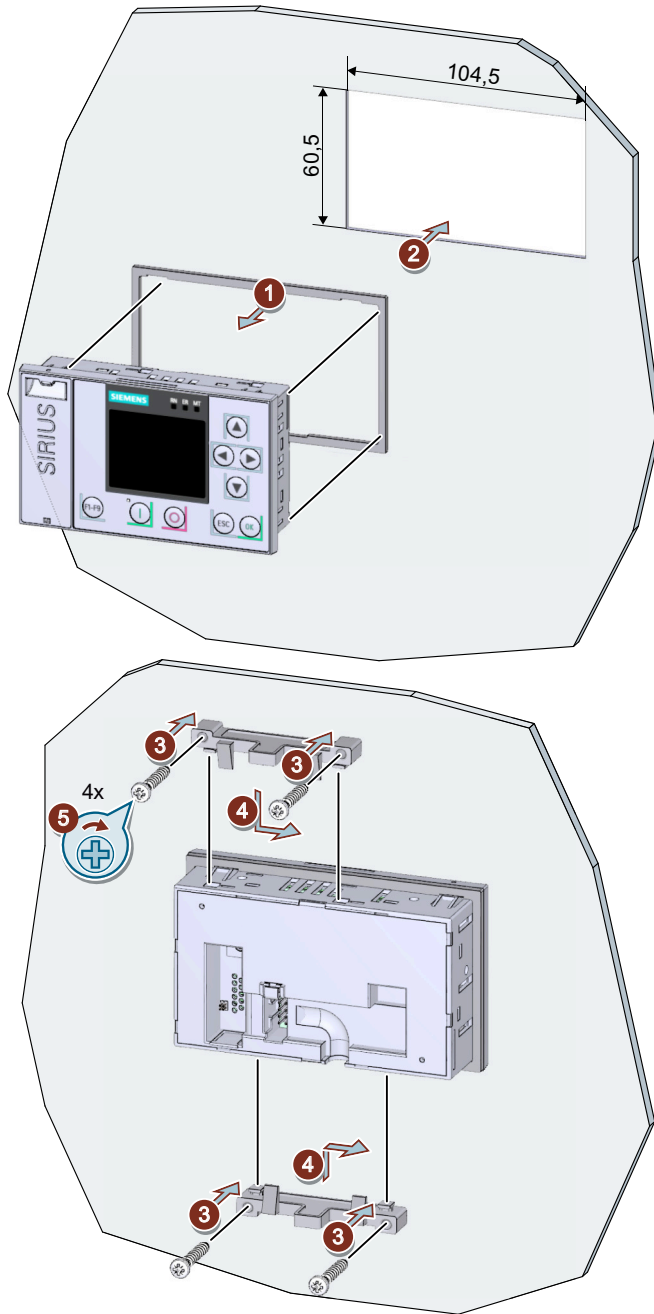

- Remove the protective film from the adhesive tape on the seal and secure the seal on the rear side of the 3RW5 HMI High Feature ①. Ensure that the seal does not overlap.
- Place the 3RW5 HMI High Feature in the cutout of the control cabinet door ②.

4.4 Installing, mounting and removing the 3RW5 HMI High Feature

- Continue to screw the screws into the fixing brackets ③ until they protrude approx. 8 mm at the front. Fasten the fixing brackets onto the 3RW5 HMI High Feature ④.
- Tighten the 3RW5 HMI High Feature with a tightening torque of 0.3 ... 0.35 Nm ⑤. Ensure that all of the screw heads are in contact with the fixing bracket.

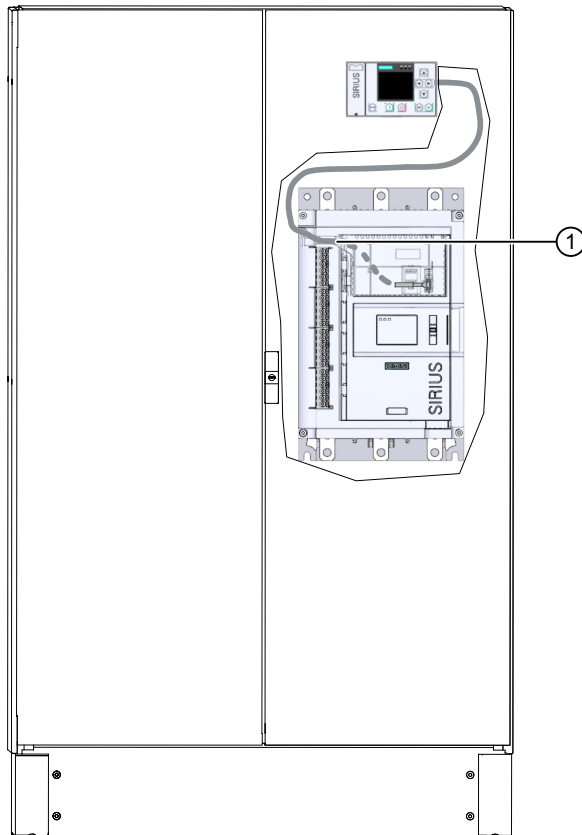
Procedure for installing the HMI connecting cable

- Use the opening to the cable duct ① to install the cable in the 3RW55 or 3RW55 Failsafe soft starter.
- It is possible to route the cable up or down in the cable duct. Make sure that you install the cable in accordance with EMC requirements. For example, install data cables separately from the motor cable. Connect both sides of shielded cables over a large surface area.

Procedure for connecting with the HMI connecting cable

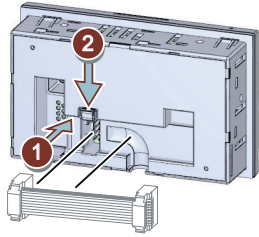

- Observe the coding of the plug and socket ①.
- Lock the connector in the socket ②.
- The HMI connecting cable in the cable duct of the 3RW5 HMI High Feature may only be routed downward.
Make sure that you install the cable in accordance with EMC requirements. For example, route data cables separately from the motor cable. Connect both sides of shielded cables over a large surface area.

Result

You have installed the 3RW5 HMI High Feature in the cabinet door and can commission (Page 129) it.

4.4.5 Replacing the hinged cover of the 3RW55 or 3RW55 Failsafe soft starter

Requirements

- Suitable hinged cover with or without cutout (accessory)

Procedure

NOTICE
Damage to the HMI display Ensure that the display of the 3RW5 HMI High Feature does not sustain damage when replacing the hinged cover.

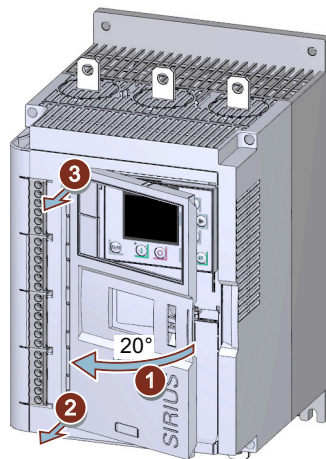
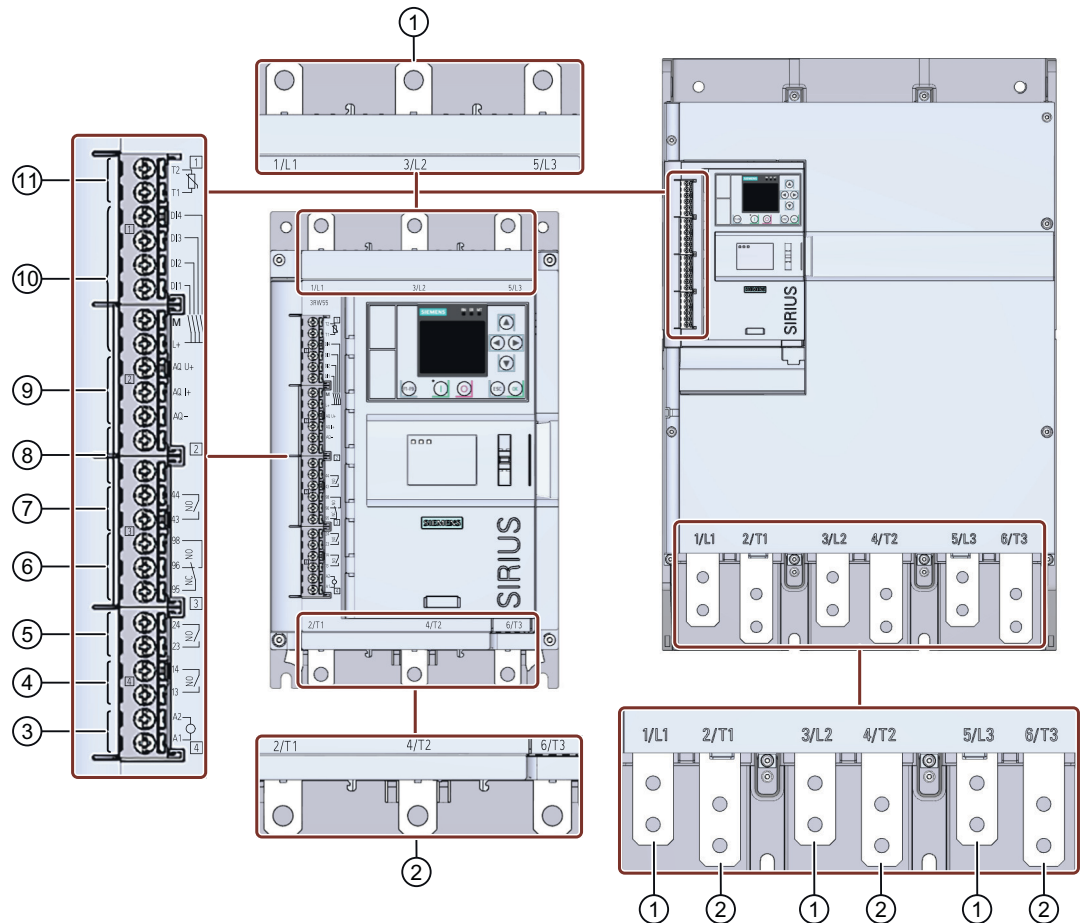

Illustration similar

- Open the hinged cover ① at an angle of approx. 20°.
- Loosen the hinges vertical to the soft starter surface ② / ③ starting from the bottom.
- Take the cover off the 3RW55 or 3RW55 Failsafe soft starter.
- Follow the steps in reverse order to install the replacement hinged cover.

Connecting

5.1 Overview of all connections of the 3RW55 soft starter



- ① Main circuit connection, line side 1/L1, 3/L2, 5/L3
- ② Main circuit connection, load (motor) side 2/T1, 4/T2, 6/T3
- ③ A1 / A2: Supply voltage (control supply voltage) for control terminals (24 V AC/DC or 110 - 250 V AC)
- ④ Output 13, 14 (output 1): For signaling operating states and faults (parameterizable (Page 200))
- ⑤ Output 23, 24 (output 2): For signaling operating states and faults (parameterizable (Page 200))
- ⑥ Output 95, 96 and 98 (output 3): For signaling faults
- ⑦ Output 43, 44 (output 4): For signaling operating states and faults (parameterizable (Page 200))
- ⑧ Not assigned
- ⑨ Analog output AQ-, AQ I+ and AQ U+: For outputting different measured values
 - AQ- / AQ U+: For signal type voltage, signal range 0 ... 10 V
 - AQ- / AQ I+: For signal type current, signal range 4 - 20 mA

5.1 Overview of all connections of the 3RW55 soft starter

- ⑩ Control inputs DI1, DI2, DI3, DI4, L+ and M
 - ⑪ Thermistor motor protection T1 and T2: Connection of an optional temperature sensor
-

Note

Parameterizing the analog output

You can parameterize the output of the analog output with the 3RW5 HMI High Feature (Page 204).

5.2 Overview of all connections of the 3RW55 Failsafe soft starter

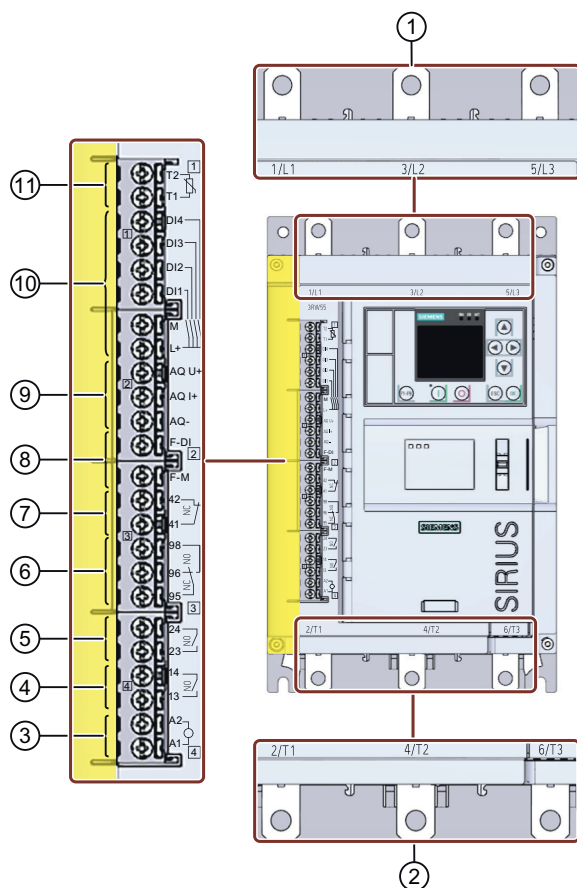

- ① Main circuit connection, line side 1/L1, 3/L2, 5/L3
- ② Main circuit connection, load (motor) side 2/T1, 4/T2, 6/T3
- ③ A1 / A2: Supply voltage (control supply voltage) for control terminals (24 V AC/DC or 110 - 250 V AC)
- ④ Output 13, 14 (output 1): For signaling operating states and faults (parameterizable (Page 200))
- ⑤ Output 23, 24 (output 2): For signaling operating states and faults (parameterizable (Page 200))
- ⑥ Output 95, 96 and 98 (output 3): For signaling faults
- ⑦ Output 41, 42 (output 4, F-RQ): Failsafe signaling output (not parameterizable)
- ⑧ F-DI: Failsafe digital input (not parameterizable)
F-M: Failsafe input ground (not parameterizable)
- ⑨ Analog output AQ-, AQ I+ and AQ U+: For outputting different measured values
 - AQ- / AQ U+: For signal type voltage, signal range 0 ... 10 V
 - AQ- / AQ I+: For signal type current, signal range 4 - 20 mA
- ⑩ Control inputs DI1, DI2, DI3, DI4, L+ and M
- ⑪ Thermistor motor protection T1 and T2: Connection of an optional temperature sensor

Note

Parameterizing the analog output

You can parameterize the output of the analog output with the 3RW5 HMI High Feature (Page 204).

5.3 Connecting 3RW55 and 3RW55 Failsafe soft starters

Requirements

- Observe the conductor cross-sections and tightening torques in the data sheet or on the front of the 3RW55 or 3RW55 Failsafe soft starter beneath the hinged cover.
- Note the required tools indicated on the front of the 3RW55 or 3RW55 Failsafe soft starter beneath the hinged cover.
- Size 5: Terminal cover
- Optional accessories:
 - Terminal cover for 3RW55 or 3RW55 Failsafe soft starter in sizes 2, 3, and 4

Procedure



 DANGER
Hazardous voltage. Will cause death or serious injury.
Turn off and lock out all power supplying this device before working on this device.

1. Connect the main circuit connections (line side/motor side) of the 3RW55 or 3RW55 Failsafe soft starter (Page 77).
2. On size 5, mount the terminal covers (optional on sizes 2, 3 and 4) (Page 78).
3. Connect the control terminals of the 3RW55 or 3RW55 Failsafe soft starter.
 - Connecting the control terminals (screw terminals) (Page 82)
 - Connecting the control terminals (spring-type terminals) (Page 84)
4. Mount the supplied cover for the control cable duct (Page 88).

Result

The 3RW55 or 3RW55 Failsafe soft starter is connected and ready to operate.

5.4 Connecting the 3RW55 and 3RW55 Failsafe soft starters to the main circuit connection (line side/motor side)

Requirements

- Observe the conductor cross-sections and tightening torques in the data sheet or on the front of the 3RW55 or 3RW55 Failsafe soft starter beneath the hinged cover.
- Note the required tools indicated on the front of the 3RW55 or 3RW55 Failsafe soft starter beneath the hinged cover.
- If you use a bar connection, you require wrenches of widths A/F 13 and 17.

Size	Article No.	Tightening torque	Screw size
Size 1	3RW551.-....	2 ... 2.5 Nm	-
Size 2	3RW552.-....	4.5 ... 6 Nm	M6x25 (bar connection)
Size 3	3RW553.-....	10 ... 14 Nm	M8x25
Size 4	3RW554.-....	14 ... 24 Nm	M10x35
Size 5	3RW555.-....	20 ... 35 Nm	M12x40



! DANGER

Hazardous voltage.
Can cause death or serious injury.

Turn off and lock out all power supplying this device before working on this device.

Procedure for screw connection - sizes 1 and 2

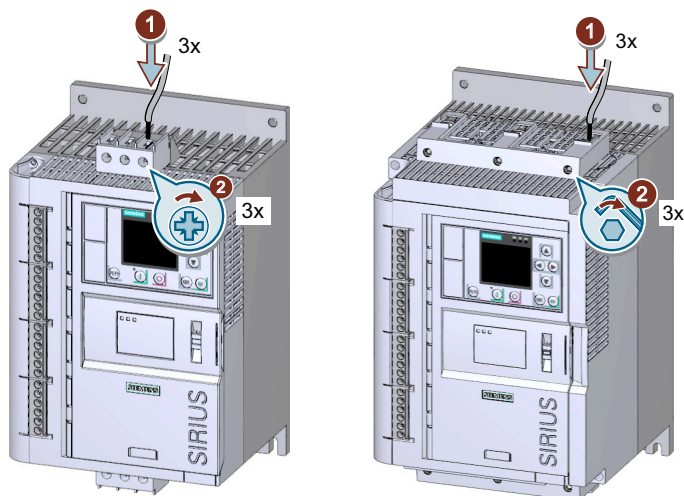

Illustration similar

- Connect connection 1/L1, 3/L2, 5/L3 to the supply system ① and tighten the screws ②.
- Repeat steps ① / ② for connection 2/T1, 4/T2, 6/T3 with the motor.

5.5 Mounting terminal covers on main circuit connections

Alternatively, you can also connect the 3RW55 and 3RW55 Failsafe soft starters with size 2 with bar connection without the box terminal block.

Procedure for bar connection - sizes 2, 3, 4 and 5

Pay attention to the diagram on the packaging of the connection set.

- Connect the terminals 1/L1, 3/L2, 5/L3 to the power supply.
- Connect the terminals 2/T1, 4/T2, 6/T3 to the motor.

Note

Cable routing for size 5

Note that the main connection cables and main connection bars have to be supported. The support must be no more than 300 mm from the edge of the enclosure.

Example circuits

- Feeder assembly, type of coordination 1 fuseless (Page 293)
- Feeder assembly, type of coordination 1 with fuses (Page 295)
- Feeder assembly, type of coordination 2 (Page 296)
- Inside-delta circuit (Page 297)

5.5 Mounting terminal covers on main circuit connections

Requirements

- Sizes 2 - 4: Terminal cover (accessory) for the 3RW55 or 3RW55 Failsafe soft starter
- Size 5:
 - Terminal cover for 3RW55 soft starter
 - Screwdriver TX25

Note

Touch protection by terminal cover

Touch protection according to EN 50274 finger-safe only for vertical contact from the front.

Procedure for sizes 2 - 4

! DANGER

**Hazardous voltage.
Will cause death or serious injury.**

Turn off and lock out all power supplying this device before working on this device.

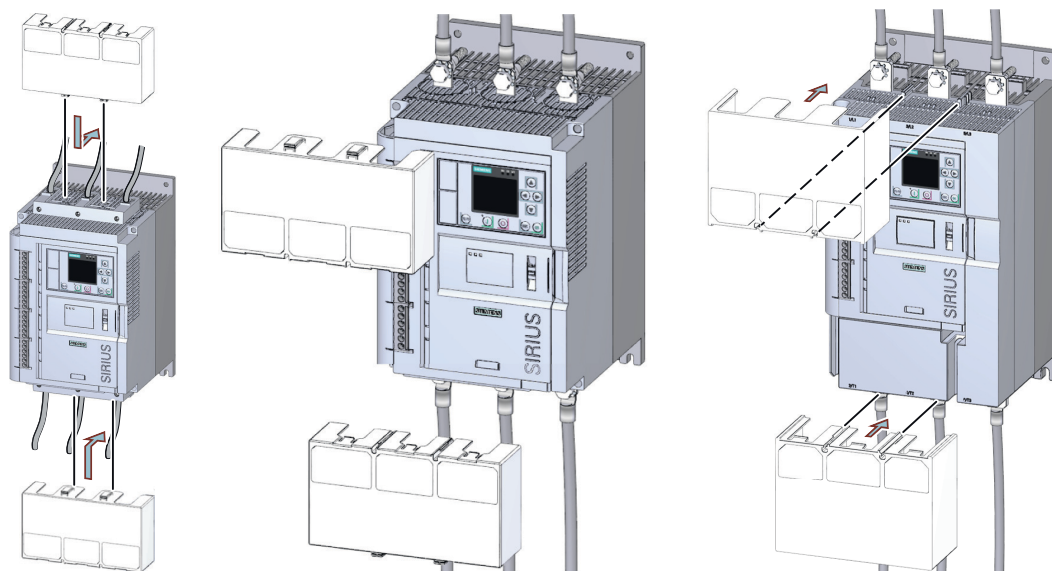

Illustration similar

- Make sure that you mount the terminal cover the right way round, as shown in the diagram.
- If you have to remove the terminal cover, proceed in the reverse order.

Procedure for size 5

! DANGER

**Hazardous voltage.
Will cause death or serious injury.**

Turn off and lock out all power supplying this device before working on this device.

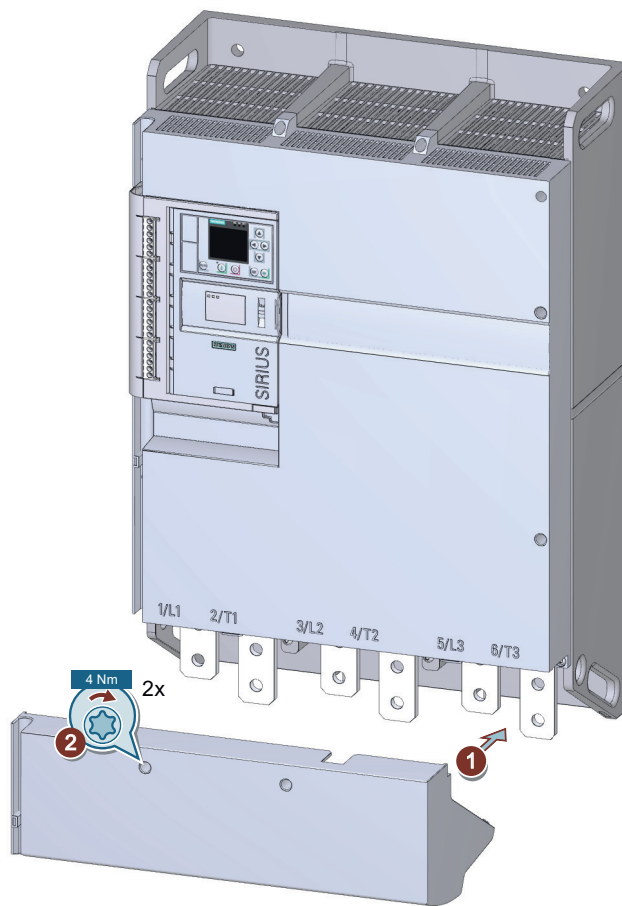

- Plug the terminal cover into the top of the enclosure of the soft starter ① and tighten the screws with a torque of 4 Nm.
- If you have to remove the terminal cover, proceed in the reverse order.

5.6 Replacement of the box terminal blocks with size 2

Requirements

- Note the required tools indicated on the front of the 3RW55 or 3RW55 Failsafe soft starter beneath the hinged cover.
- Main circuit connection (line side/motor side) is disconnected from the 3RW55 or 3RW55 Failsafe soft starter.

Procedure for removal

**! DANGER**

Hazardous voltage.
Will cause death or serious injury.

Turn off and lock out all power supplying this device before working on this device.

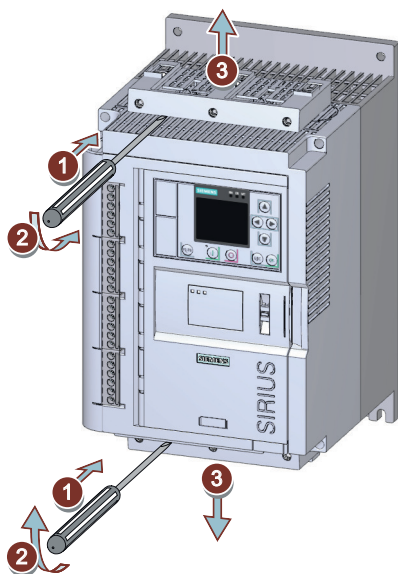

Illustration similar

- Pry the box terminal block off the main circuit connections ① / ②.
- Pull the box terminal block off the main circuit connections ③.

Assembly procedure

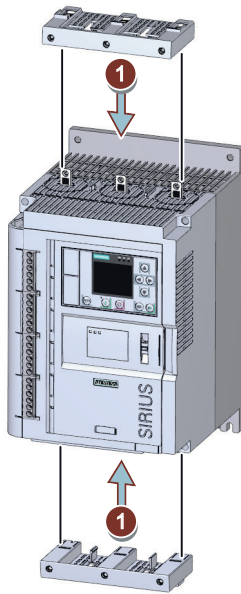

Illustration similar

- Plug the new box terminal block into the main circuit connections ①.

5.7 Connecting the control terminals (screw terminals)

Requirements

- Observe the conductor cross-sections and tightening torques in the data sheet or on the front of the 3RW55 or 3RW55 Failsafe soft starter beneath the hinged cover.
- Note the required tools indicated on the front of the 3RW55 or 3RW55 Failsafe soft starter beneath the hinged cover.

Procedure



! DANGER
Hazardous voltage.
Will cause death or serious injury.
Turn off and lock out all power supplying this device before working on this device.

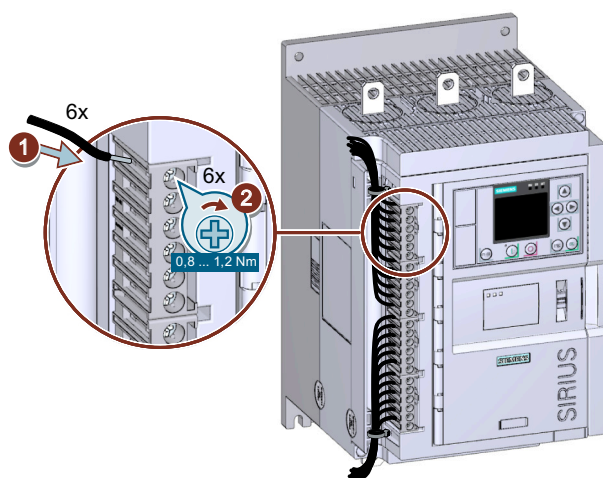

Illustration similar

Example circuits

You will find further information on connecting the control terminals in chapters Control circuit connection (Page 301) and Special applications (Page 307).

5.8 Disconnecting the control current from the screw-type terminals

Requirements

- Note the required tools indicated on the front of the 3RW55 or 3RW55 Failsafe soft starter beneath the hinged cover.

Procedure



! DANGER

**Hazardous voltage.
Will cause death or serious injury.**

Turn off and lock out all power supplying this device before working on this device.

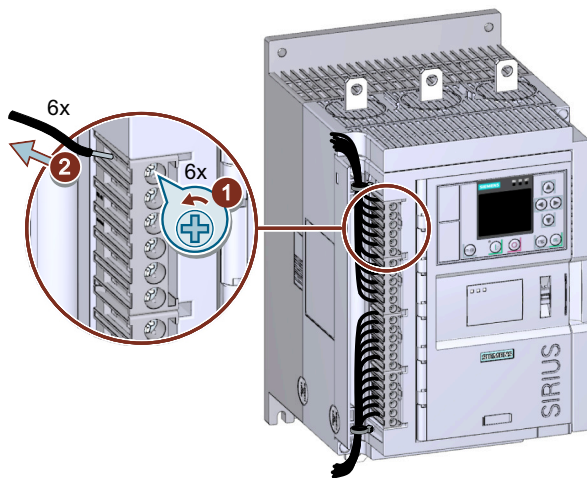

Illustration similar

5.9 Connecting the control terminals (spring-type terminals)

Requirements

- Observe the conductor cross-sections and tightening torques in the data sheet or on the front of the 3RW55 or 3RW55 Failsafe soft starter beneath the hinged cover.
- Note the required tools indicated on the front of the 3RW55 or 3RW55 Failsafe soft starter beneath the hinged cover.

Procedure



! DANGER

**Hazardous voltage.
Will cause death or serious injury.**

Turn off and lock out all power supplying this device before working on this device.

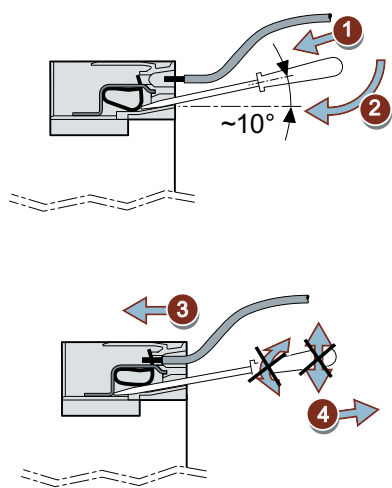
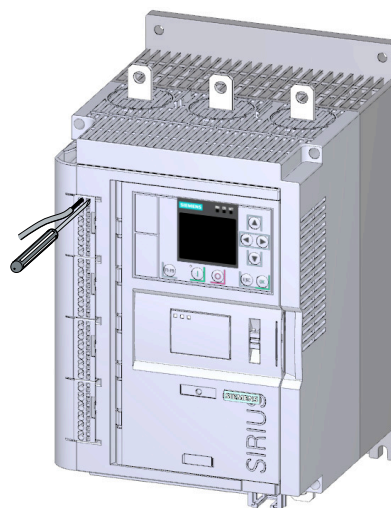

Illustration similar



Example circuits

You will find further information on connecting the control terminals in chapters Control circuit connection (Page 301) and Special applications (Page 307).

5.10 Disconnecting the control current from the spring-loaded terminals

Requirements

- Note the required tools indicated on the front of the 3RW55 or 3RW55 Failsafe soft starter beneath the hinged cover.

Procedure



! DANGER

**Hazardous voltage.
Will cause death or serious injury.**

Turn off and lock out all power supplying this device before working on this device.

5.11 Replacing the control terminals

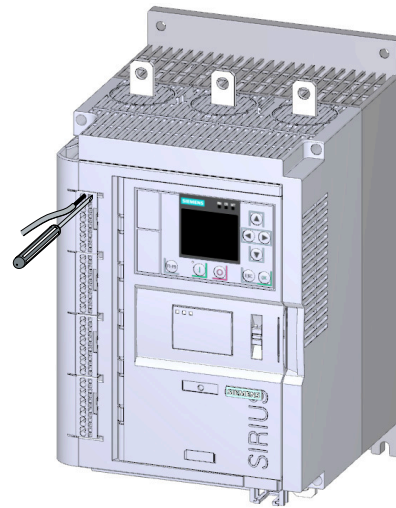
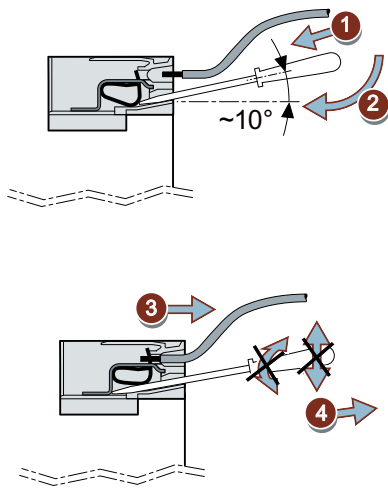

Illustration similar

5.11 Replacing the control terminals

Requirements

- Remove the cover over the control cable duct (Page 89).
- Control terminal as spare part

Type of connection	Article No.
Screw terminals	3RW5980-1TR00
Spring-loaded terminals	3RW5980-2TR00

Procedure for removal



! DANGER
Hazardous voltage.
Will cause death or serious injury.
Turn off and lock out all power supplying this device before working on this device.

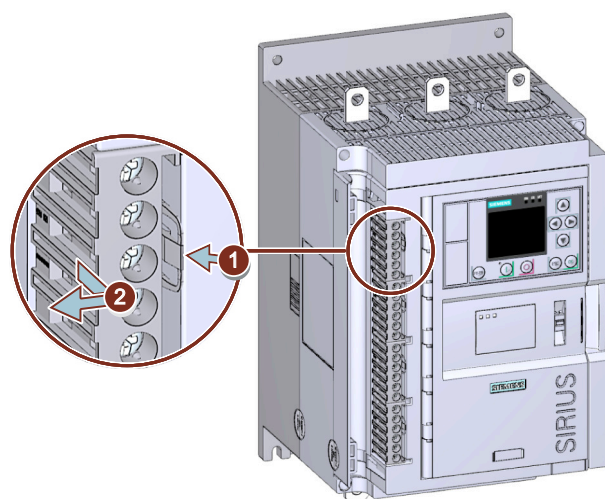

Illustration similar

- Press against the lock ① and pull the control terminal out ②.

Assembly procedure

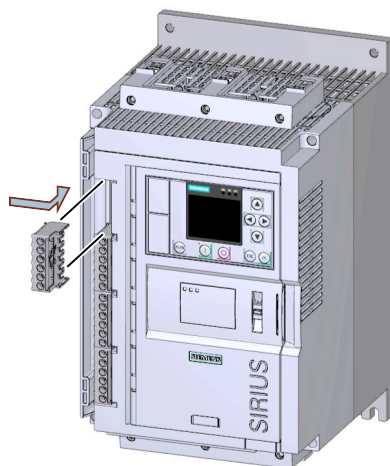

Illustration similar

- Place the control terminal onto the intended connection until the terminal engages.

5.12 Installing the cover for the control cable duct

Requirements

- 1–2 cable ties
- Cover of the control cable duct as a spare part

Soft starter	Article No.
3RW55	3RW5950-0GD20
3RW55 Failsafe	3RW5950-0GD30

Procedure

NOTICE
Damage to the cables
Make sure that the cables are not trapped prior to locking.

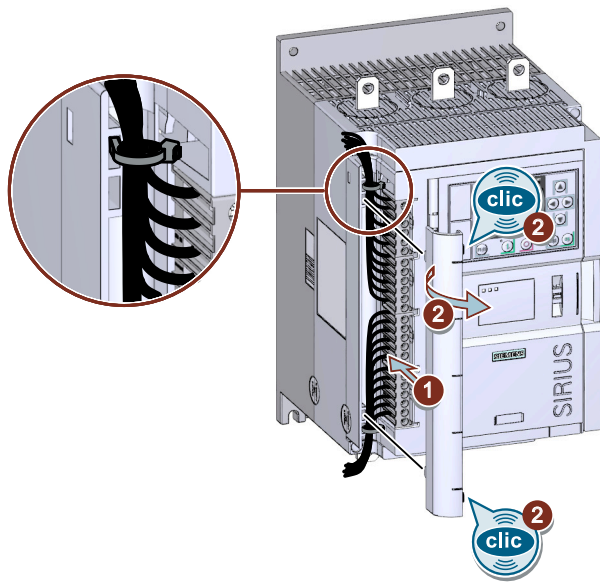

Illustration similar

- Lay the control cables in the control cable ducts and fix the control cables in place with cable ties.
- Press the cover for the control cable duct into the openings ① provided until it audibly engages ②.

5.13 Removing the cover of the control cable duct

Procedure

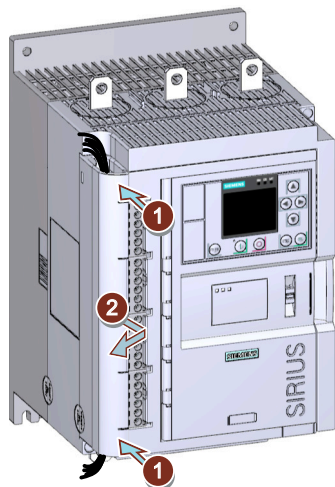

Illustration similar

- Press the cover of the control cable duct at top and bottom ① from the front and remove the cover for the control cable duct of the 3RW55 or 3RW55 Failsafe soft starter ②.

Parameter assignment

6.1 Parameterizing 3RW55 and 3RW55 Failsafe soft starters

Operating principle

In the following example of a procedure, the 3RW55 or 3RW55 Failsafe soft starter is parameterized in parameter set 1 with a 3RW5 HMI High Feature. The 3RW55 and 3RW55 Failsafe soft starters have 3 parameters sets (Page 93), e.g. to start applications with different load conditions (e.g. conveyor belt full and conveyor belt empty). To set parameter sets 2 and 3, proceed as described below. In the factory settings, parameter set 1 is active.

Note

Application wizard

To enable simple commissioning the 3RW5 HMI High Feature supports various applications with an application wizard. In the menu, navigate to "Parameters > Soft Starter > Parameter set 1 / 2 / 3 > Application wizard". You will find more information in chapter Application wizard (Page 94).

Parameterization options

- 3RW5 HMI High Feature
You will find an overview of the menu in chapter Menu of the 3RW5 HMI High Feature (Page 101).
3RW5 HMI High Feature is connected and ready for operation. Access protection to 3RW5 HMI High Feature is not active or has been reset.
- SIRIUS Soft Starter ES (TIA Portal) via the local interface on the 3RW5 HMI High Feature
Brief overview: Window "Project Navigation" with current project under created Soft Starter > "Parameters" > Window "Work area" > "Soft Starter"
- With a fieldbus via a 3RW5 communication module:
 - With SIRIUS Soft Starter ES (TIA Portal) Premium / Professional (only via a 3RW5 PROFINET or PROFIBUS communication module)
Brief overview: See SIRIUS Soft Starter ES (TIA Portal) via the local interface on the 3RW5 HMI High Feature
 - Configuration software of the control system (e.g. STEP 7 with corresponding HSP)
 - User program

You can find additional information on the parameters that can be set via the fieldbus in the manual of the respective 3RW5 communication module.

Ex operation

Refer to chapters ATEX/IECEX/UKEX (Page 18) and ATEX/IECEX/UKEX (Page 208).

Failsafe

Refer to chapters Failsafe (Page 22) and Failsafe (Page 214).

Requirements

- The 3RW55 or 3RW55 Failsafe soft starter is mounted and connected.
- Supply voltage (control supply voltage) is present.

Procedure for parameterization on the 3RW5 HMI High Feature

Set the desired parameters depending on the selected application. You will find an overview of the menu of the 3RW5 HMI in chapter Menu of the 3RW5 HMI High Feature (Page 101).

1. Set the motor parameters (Page 97).
Menu: "Parameters > Soft Starter > Parameter set 1 / 2 / 3 > Motor parameters"
2. Set the start parameters (Page 133).
Menu: "Parameters > Soft Starter > Parameter set 1 / 2 / 3 > Start settings"
Alternatively, use automatic parameterization (Page 134).
Menu: "Parameters > Soft Starter > Parameter set 1 / 2 / 3 > Automatic parameterization"
3. Set the stopping mode parameters (Page 148).
Menu: "Parameters > Soft Starter > Parameter set 1 / 2 / 3 > Stopping mode settings"
4. Set the motor protection (Page 168).
Menu: "Parameters > Soft Starter > Parameter set 1 / 2 / 3 > Motor protection"
5. Set creep speed (Page 174).
Menu: "Parameters > Soft Starter > Parameter set 1 / 2 / 3 > Creep speed"
The function is not available for the 3RW55 Failsafe soft starter.
6. Set the condition monitoring parameters (Page 176).
Menu: "Parameters > Soft Starter > Parameter set 1 / 2 / 3 > Condition Monitoring"
7. Set the asymmetry monitoring parameters (Page 188).
Menu: "Parameters > Soft Starter > Asymmetry"
8. Set ground fault monitoring (Page 189).
Menu: "Parameters > Soft Starter > Ground fault"
9. Set the emergency start (Page 191).
Menu: "Parameters > Soft Starter > Emergency start"
10. Set emergency run (Page 193).
Menu: "Parameters > Soft Starter > Emergency run"
The "Emergency run" function is not available for the 3RW55 Failsafe soft starter.
11. Set the inputs (Page 196).
Menu: "Parameters > Soft Starter > Inputs"
12. Set the outputs (Page 200).
Menu: "Parameters > Soft Starter > Outputs"
13. Set the additional parameters (Page 216).
Menu: "Parameters > Soft Starter > Additional parameters"

14. Set the date and time (Page 220).

Menu: "Parameter > Soft starter > Date and time"

15. Define the characteristics to be monitored.

– Monitoring the measured values of the 3RW55 soft starter with the 3RW5 HMI High Feature (Page 229)

Menu: "Monitoring > Measured values"

– Monitoring the process image of the 3RW55 soft starter with the 3RW5 HMI High Feature (Page 233)

Menu: "Monitoring > Process image"

Note

Last changed parameters

For each parameter set, you can view and directly modify the last 10 changed parameters.

Menu: "Parameters > Soft Starter > Parameter set 1 / 2 / 3 > Last changed parameter"

Result

The 3RW55 or 3RW55 Failsafe soft starter has been parameterized and is ready for operation. You can now optionally parameterize the 3RW5 HMI High Feature (Page 123).

If you are using a 3RW5 communication module, set its parameters. You will find further information on operation of the 3RW5 communication module in the manual of the relevant 3RW5 communication module.

6.2 Parameter sets

Operating principle

The 3RW55 and 3RW55 Failsafe soft starters provide 3 individually adjustable parameter sets, of which only one parameter set is active at a time. Different parameters can be set for each parameter set. The switchover from one parameter set to another parameter set is only possible when the motor is switched off. In the factory settings, parameter set 1 is active.

Application

- Starting Dahlander motors (variable-speed drive).
- Starting an application with different load conditions (e.g. empty or full conveyor belt).
- Separate starting of up to 3 drives with different run-up behavior (e.g. compressor and pump).

Ex operation

In Ex operation (Page 209), only parameter set 1 is active even if another parameter set is selected. Parameter sets 2 and 3 are not available in this case.

Switchover options

- 3RW5 HMI High Feature
Menu: "Control > Select parameter set > Parameter set 1 / 2 / 3"
Access protection to the 3RW5 HMI High Feature is not active or has been reset.
Refer to chapter Control via 3RW5 HMI High Feature (Page 234).
- With SIRIUS Soft Starter ES (TIA Portal) via the local interface on the 3RW5 HMI High Feature
Brief overview: Window "Task Card" > Tab "Online Tools" > "SIRIUS Control Panel"
- Input action (Page 196)
- With a fieldbus via a 3RW5 communication module:
 - With SIRIUS Soft Starter ES (TIA Portal) Premium / Professional (only via a 3RW5 PROFINET or PROFIBUS communication module)
Brief overview: See SIRIUS Soft Starter ES (TIA Portal) via the local interface on the 3RW5 HMI High Feature
 - Configuration software of the control system (e.g. STEP 7 with corresponding HSP)
 - User program

You can find additional information on the parameters that can be set via the fieldbus in the manual of the respective 3RW5 communication module.

6.3 Application wizard

Operating principle

The application wizard enables easy commissioning by suggesting a suitable selection of parameters for specific applications. A user-defined application can additionally be created. The application wizard can be used for any parameter set.

Setting via 3RW5 HMI High Feature

Menu: "Parameters > Soft Starter > Parameter set 1 / 2 / 3 > Application wizard"

Access protection to the 3RW5 HMI High Feature is not active or has been reset.

Procedure

1. The menu of the 3RW5 HMI High Feature provides you with a list of suggested settings (Page 95) that is reduced to just the relevant parameters.
All parameters that are not displayed remain unchanged.
2. Check the parameters and modify them if necessary.

User-defined application

To create a user-defined application, perform the following steps:

1. Choose menu item "User defined" and modify the parameters as you require them. Confirm your input with the OK key.
2. Choose menu item "Reset default parameter". Confirm your input with the OK key.
3. To save the application parameters, exit the menu with the ESC key and confirm the user information "Save application parameter?" with the OK key.
The application parameter has been saved. You can reset to the default parameters of the user-defined application with the menu item "Set default parameter" or with the factory setting of the 3RW55 or 3RW55 Failsafe soft starter.

Result

The parameterization has been performed for the selected application. You can make changes to parameters at any time in the "Parameters" menu.

6.4 Suggested settings of the application wizard

Parameter	Small ventilator (fan)	Big ventilator (fan)	Pump
Rated operational current I_e	Rated operational current I_e of the 3RW55 or 3RW55 Failsafe soft starter used		
Starting mode	Voltage ramp + Current limiting	Torque control + Current limiting	Voltage ramp + Current limiting
Current limiting value	400%	400%	400%
Starting voltage	40%	Not relevant	40%
Ramp up time	4 s	10 s	10 s
Starting torque	Not relevant	30%	Not relevant
Limiting torque	Not relevant	150%	Not relevant
Stopping mode	Coasting down	Coasting down	Pump stopping mode
Stopping time	Not relevant	Not relevant	10 s
Stopping torque	Not relevant	Not relevant	10%
Trip class	CLASS 10E	CLASS 30E	CLASS 10E

Parameter	Hydraulic pump	Compressors	Conveyor belts
Rated operational current I_e	Rated operational current I_e of the 3RW55 or 3RW55 Failsafe soft starter used		
Starting mode	Voltage ramp + Current limiting	Torque control + Current limiting	Torque control
Current limiting value	400%	400%	Not relevant
Starting voltage	40%	Not relevant	Not relevant
Ramp up time	10 s	4 s	10 s
Starting torque	Not relevant	50%	70%
Limiting torque	Not relevant	150%	150%

6.4 Suggested settings of the application wizard

Parameter	Hydraulic pump	Compressors	Conveyor belts
Stopping mode	Coasting down	Coasting down	Torque control
Stopping time	Not relevant	Not relevant	10 s
Stopping torque	Not relevant	Not relevant	10%
Trip class	CLASS 10E	CLASS 10E	CLASS 10E

Parameter	Roller conveyor	Agitator	Centrifuge
Rated operational current I_e	Rated operational current I_e of the 3RW55 or 3RW55 Failsafe soft starter used		
Starting mode	Torque control	Voltage ramp + Current limiting	Voltage ramp + Current limiting
Current limiting value	Not relevant	400%	400%
Starting voltage	Not relevant	40%	40%
Ramp up time	10 s	4 s	4 s
Starting torque	60%	Not relevant	Not relevant
Limiting torque	150%	Not relevant	Not relevant
Stopping mode	Torque control	Coasting down	Coasting down
Stopping time	10 s	Not relevant	Not relevant
Stopping torque	10%	Not relevant	Not relevant
Trip class	CLASS 10E	CLASS 20E	CLASS 20E

Parameter	Milling machine	Mills	Crushers
Rated operational current I_e	Rated operational current I_e of the 3RW55 or 3RW55 Failsafe soft starter used		
Starting mode	Voltage ramp + Current limiting	Voltage ramp + Current limiting	Voltage ramp + Current limiting
Current limiting value	400%	400%	400%
Starting voltage	40%	50%	50%
Ramp up time	4 s	10 s	10 s
Starting torque	Not relevant	Not relevant	Not relevant
Limiting torque	Not relevant	Not relevant	Not relevant
Stopping mode	Coasting down	Coasting down	Coasting down
Stopping time	Not relevant	Not relevant	Not relevant
Stopping torque	Not relevant	Not relevant	Not relevant
Trip class	CLASS 20E	CLASS 30E	CLASS 30E
Breakaway time	Not relevant	0.3 s	0.3 s
Breakaway voltage	Not relevant	80%	80%

Parameter	Circular saws/band saws	User defined
Rated operational current I_e	Rated operational current I_e of the 3RW55 or 3RW55 Failsafe soft starter used	
Starting mode	Torque control + Current limiting	Torque control + Current limiting
Current limiting value	400%	400%
Starting voltage	Not relevant	40%
Ramp up time	10 s	10 s

Parameter	Circular saws/band saws	User defined
Starting torque	30%	50%
Limiting torque	150%	150%
Stopping mode	Coasting down	Coasting down
Stopping time	Not relevant	10 s
Stopping torque	Not relevant	10%
Trip class	CLASS 30E	CLASS 10E
Breakaway time	Not relevant	0 s (deactivated)
Breakaway voltage	Not relevant	0% (deactivated)

6.5 Motor parameters

Operating principle

On the 3RW55 and 3RW55 Failsafe soft starters, you can set the motor parameters "Rated operational current I_e ", "Service factor", "Rated torque", "Rated operating speed" and "Motor connection type". Setting of the rated operational current I_e is the minimum requirement for operation. The motor parameters are located on the rating plate of the three-phase induction motor being used. You will find a description of all other parameters in chapter Functions (Page 131).

Setting options

- 3RW5 HMI High Feature
Menu: "Parameters > Soft Starter > Parameter set 1 / 2 / 3 > Motor parameters"
Access protection to the 3RW5 HMI High Feature is not active or has been reset.
- With SIRIUS Soft Starter ES (TIA Portal) via the local interface on the 3RW5 HMI High Feature
Brief overview: Window "Project Navigation" with current project under created Soft Starter > "Parameters" > Window "Work area" > "Soft Starter > Parameter set 1 / 2 / 3 > Motor parameters"
- With a fieldbus via a 3RW5 communication module:
 - With SIRIUS Soft Starter ES (TIA Portal) Premium / Professional (only via a 3RW5 PROFINET or PROFIBUS communication module)
Brief overview: See SIRIUS Soft Starter ES (TIA Portal) via the local interface on the 3RW5 HMI High Feature
 - Configuration software of the control system (e.g. STEP 7 with corresponding HSP)
 - User program

You can find additional information on the parameters that can be set via the fieldbus in the manual of the respective 3RW5 communication module.

Rated operational current I_e

The rated operational current I_e is the current that can be continuously conducted by the feeder (switchgear and motor). Normally this is the rated current I_e of the motor. The setting range depends on the rating class of the 3RW55 or 3RW55 Failsafe soft starter.

Note

Electronic motor overload protection

The electronic motor overload protection (Page 168) can be switched off. In this case, motor overload protection must be ensured by means of a temperature sensor (Page 171) in the motor (thermistor motor protection with temperature sensor).

Service factor

Three-phase motors have a service factor that is stated relative to the rated power of the motor. The service factor determines the maximum permissible overload factor of the motor in the ramped-up status. A service factor of, for example, 1.15 means that you can operate the motor up to 1.15 times the rated power without damaging it permanently.

To be able to use these higher motor power ratings, you must set the parameter "Service factor" on the 3RW55 or 3RW55 Failsafe soft starter so that the motor overload protection is triggered after an appropriate delay. If a service factor has been specified by the manufacturer, set this service factor. If no service factor is specified, set service factor 1.0 (factory setting).

Note the different trip characteristics for a service factor ≤ 1.05 and > 1.05 in the Internet (<https://support.industry.siemens.com/cs/ww/en/ps/25099/char>).

Setting range	Factory setting	Increment
1.0 ... 1.15	1.0	0.01

Rated torque

If the motor's rated torque is not indicated on the rating plate, you can calculate it using the following formula:

$$\text{Rated torque (Nm)} = \text{Power (kW)} \times (9\,550 / \text{rated operating speed (rpm)})$$

For the setting "0 Nm" (factory setting), the 3RW55 and 3RW55 Failsafe soft starters calculate the required value automatically.

Setting range	Factory setting	Increment
0 ... 10 000 Nm	0 Nm	1 Nm

Rated operating speed

The rated operating speed is required for calculating the current rated torque.

Setting range	Factory setting	Increment
500 ... 3 600 rpm	1 500 rpm	1 rpm

Motor connection type

In the 3RW5 HMI High Feature, the menu item is "Type of connection".

Motor connection type	Description
Automatic detection	The 3RW55 or 3RW55 Failsafe soft starter detects the motor connection type (standard (inline) circuit or inside-delta circuit) automatically if the main supply voltage (operational voltage) is applied and the motor is connected to the 3RW55 or 3RW55 Failsafe soft starter. Thus no parameterization of the motor connection type is necessary.
Standard	The connections of the 3RW55 or 3RW55 Failsafe soft starter are wired into the motor feeder between the motor starter protector and the motor.
Inside-delta	The inside-delta circuit makes it possible to increase the operable motor power of the individual 3RW55 or 3RW55 Failsafe soft starters by a factor of root 3. Operation in inside-delta circuit is only possible for operating voltages up to 600 V.

Example: A 3RW55 soft starter 720 A can be used in standard (inline) circuit for 400 kW motors, in inside-delta circuit for 710 kW motors.

6.6 Design and operator controls of the High Feature 3RW5 HMI

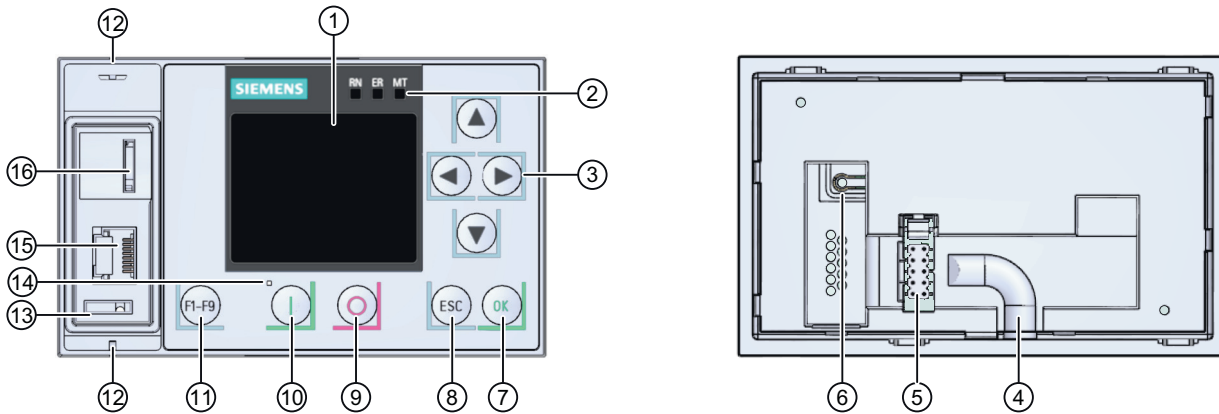









- ① Display
- ② Device LEDs (Page 249)
- ③ Navigation keys
- ④ Cable duct
- ⑤ Plug-in connection for HMI connecting cable
- ⑥ Master RESET key
- ⑦ OK key
- ⑧ ESC key
- ⑨ Motor stop key
- ⑩ Motor start key
- ⑪ Function selection key
- ⑫ Eyes for lead seals
- ⑬ Hole for mounting the interface cover
- ⑭ Status LED (Page 251)
- ⑮ Local interface (point-to-point connection between PC and 3RW5 HMI High Feature)
- ⑯ Slot for micro SD card (Page 245)

Navigating and setting

The keys are used for navigation, for selecting and setting menu items and for executing predefined actions.

Key	Actions
▶	<ul style="list-style-type: none"> • Move one position to the right in the input field • Displaying and switching over graphs. You will find more information in chapter Graphical display of measured values on the 3RW5 HMI High Feature (Page 231).
◀	<ul style="list-style-type: none"> • Move one position to the left in the input field • Switching over graphs. You will find more information in chapter Graphical display of measured values on the 3RW5 HMI High Feature (Page 231).

Key	Actions
	<ul style="list-style-type: none"> • Jump to next menu item • Set number or letter
	<ul style="list-style-type: none"> • Jump to previous menu item • Set number or letter
	<ul style="list-style-type: none"> • To confirm • To open the menu • Jump to selected menu item
	<ul style="list-style-type: none"> • To exit the menu
	<ul style="list-style-type: none"> • Motor stops as parameterized if the 3RW5 HMI High Feature has control
	<ul style="list-style-type: none"> • Motor starts as parameterized if the 3RW5 HMI High Feature has control. After an error has been acknowledged when using the 3RW5 HMI High Feature, you must repeat the ON command by pressing the "Motor Start" key.
	<ul style="list-style-type: none"> • F1: Local/Remote: Changes master control • F2: Reset • F3 ... F9: Freely parameterizable
	Master RESET key for restoring the factory setting (Page 282).

Master control function of the 3RW5 HMI High Feature

The 3RW5 HMI High Feature supports you by fetching master control if this is required for execution of a function. If the 3RW5 HMI High Feature does not have master control (Remote), the following information appears on the display of the 3RW5 HMI High Feature when a function is entered:

"HMI does not have the control for the starter" - "Do you want the HMI to fetch the control?"

If you confirm the information with the OK key, the 3RW5 HMI High Feature fetches master control (Local). To execute the function, you must then enter it again.





Refer to chapter Operating modes and master control function (Page 34).



6.7 Menu of the 3RW5 HMI High Feature

This chapter explains the full menu of the 3RW5 HMI High Feature. Depending on the following points, contents may or may not be available:

- 3RW55 or 3RW55 Failsafe soft starter
- Up-to-date status of the firmware (Page 24)
This chapter refers to the necessary firmware version of the 3RW5 HMI High Feature. If a newer firmware version of the 3RW55 or 3RW55 Failsafe soft starter is required, refer to the description of the respective function.
- 3RW5 communication module

Overview of the main menu options on the 3RW5 HMI High Feature

Monitoring	Diagnosis	Control	Parameters
			

Overview	Security	Micro SD card ¹⁾
		

¹⁾ Only visible if a micro SD card is plugged.

Additional information

Menu item "Additional information" shows the following QR code. The link behind the QR code is the 3RW5 topic page (<https://support.industry.siemens.com/cs/ww/en/view/109747404>).



Menu of the 3RW5 HMI High Feature

Monitoring [1/1]	
↓	
Measured values	
<ul style="list-style-type: none"> - Phase currents (%) <ul style="list-style-type: none"> └ I L1 └ I L2 └ I L3 └ Average └ Show bar chart¹⁾ - Phase currents (rms) <ul style="list-style-type: none"> └ I L1 └ I L2 └ I L3 └ Average └ I L1/L2/L3 max └ Show bar chart¹⁾ - Asymmetry - Motor voltage <ul style="list-style-type: none"> └ U L1-L2 └ U L2-L3 └ U L3-L1 - Power <ul style="list-style-type: none"> └ Active power └ Power factor L1...3 - Line frequency - Output frequency - Motor temperature rise - Remaining time for motor overload protection - Remaining motor cooling time - Remaining switching element cooling time - Switching element heating - Remaining switching frequency monit. time 	
Process image	
<ul style="list-style-type: none"> - Process image input (PII) <ul style="list-style-type: none"> └ Ready (automatic) └ Motor On └ Group error └ [...]²) - Process image output (PIQ) <ul style="list-style-type: none"> └ Motor CW └ Motor CCW └ Reset └ [...]²) 	
Additional information	

¹⁾ 3RW5 HMI High Feature from firmware version V3.0

²⁾ Further menu items. Refer to chapters Monitoring the process image of the 3RW55 soft starter with the 3RW5 HMI High Feature (Page 233) and Process data and process images (Page 198).

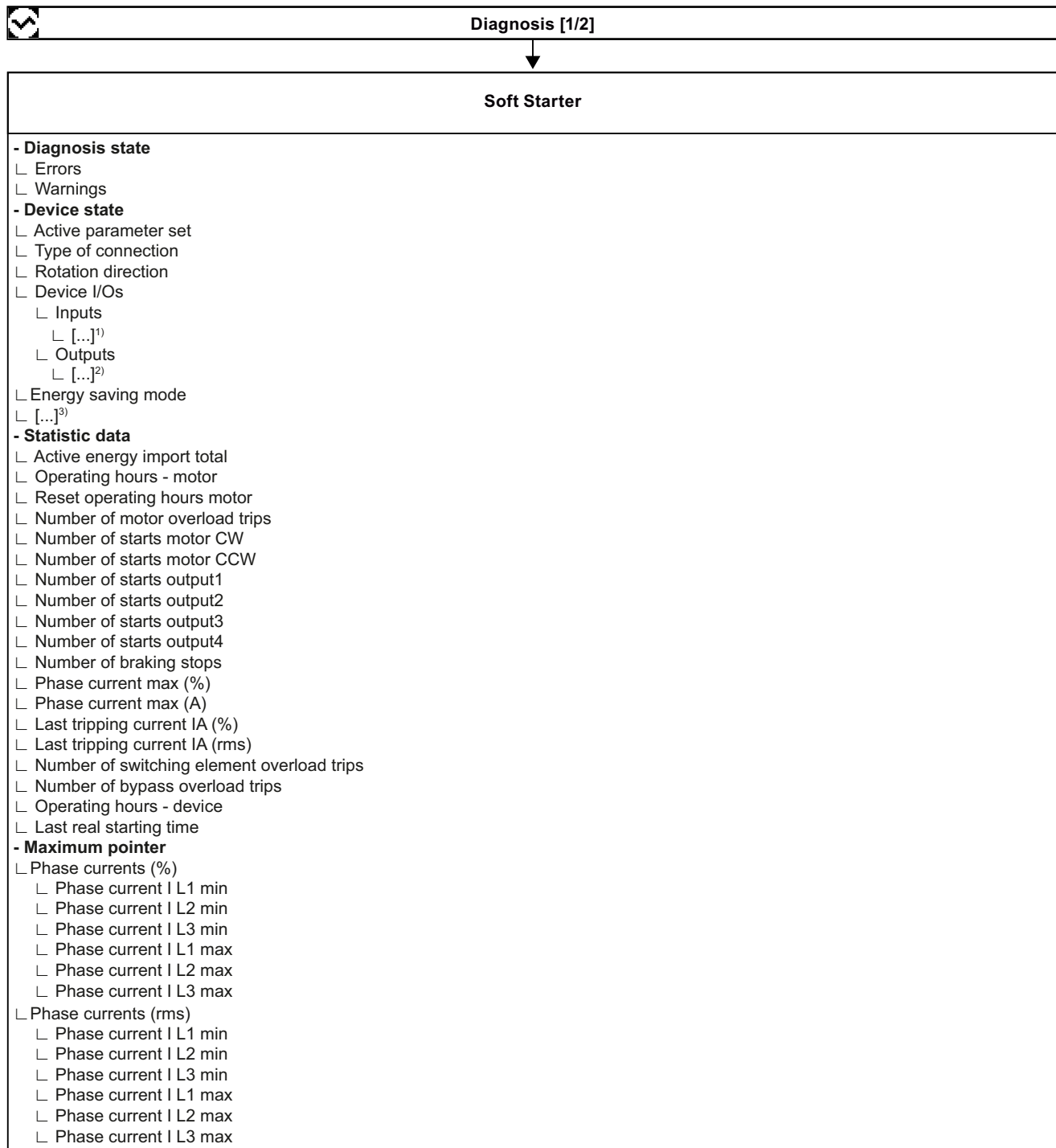

1) Display of active inputs

2) Display of active outputs

3) Further menu items. Refer to chapter Performing diagnostics on the 3RW55 and 3RW55 Failsafe soft starters using the 3RW5 HMI High Feature (Page 260).

Diagnosis [2/2]	
↓	
Soft Starter	
<ul style="list-style-type: none"> └ Line-to-line voltages (rms) <ul style="list-style-type: none"> └ U L1-L2 min └ U L2-L3 min └ U L3-L1 min └ U L1-L2 max └ U L2-L3 max └ U L3-L1 max └ Maximum trigger current (%) └ Maximum trigger current (A) └ Number of motor overload trips └ Number of starts with ext. bypass¹⁾ └ Minimum line frequency └ Maximum line frequency └ Maximum switching element heating └ Reset maximum pointer - Self-test - Logbooks <ul style="list-style-type: none"> └ Application └ Device └ Security └ Service └ Delete <ul style="list-style-type: none"> └ Application 	
Communication module	
<ul style="list-style-type: none"> - Diagnosis state <ul style="list-style-type: none"> └ Errors └ Prewarnings └ Device state²⁾ 	
HMI	
<ul style="list-style-type: none"> - Diagnosis state <ul style="list-style-type: none"> └ Errors └ Warnings └ Device state - Self-test <ul style="list-style-type: none"> └ Test LEDs └ Test buttons └ Test display 	
Additional information	

¹⁾ 3RW5 HMI High Feature from firmware version V2.0

²⁾ For 3RW5 PROFINET High Feature communication module only

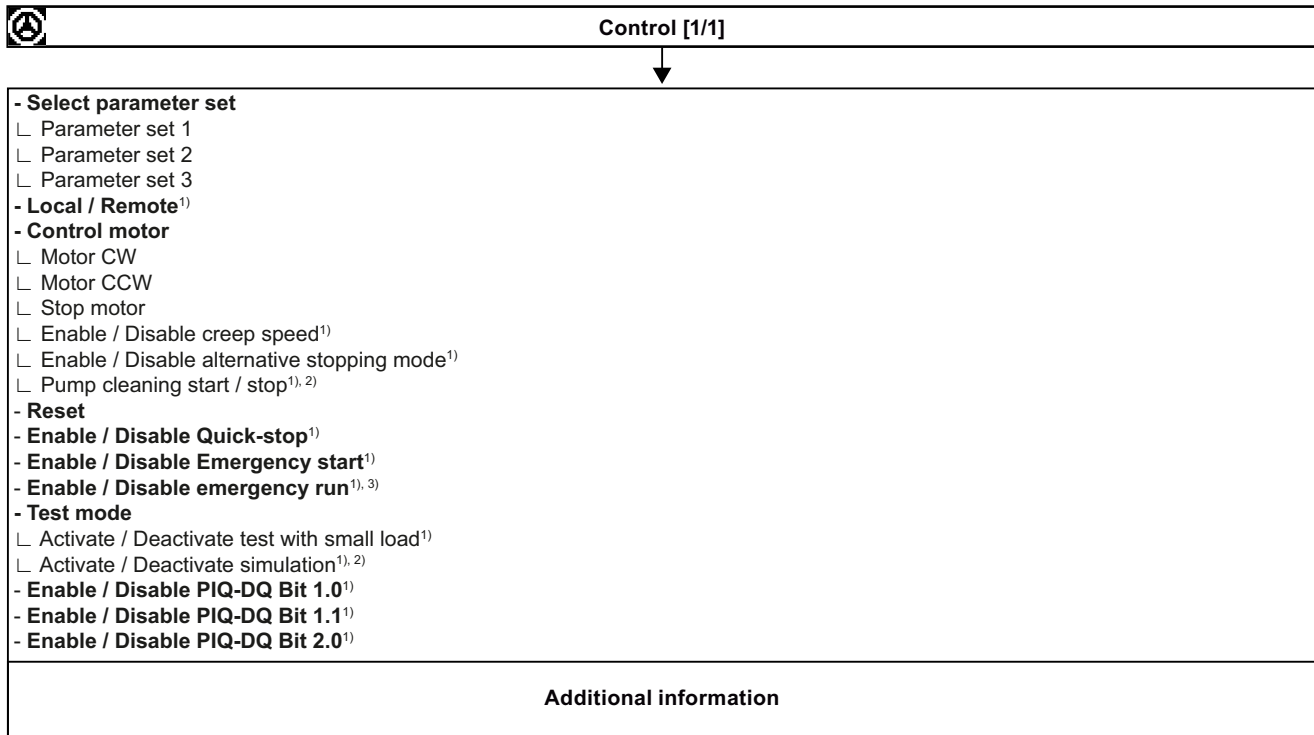

1) Display depends on the current setting

2) 3RW5 HMI High Feature from firmware version V2.0

3) 3RW5 HMI High Feature from firmware version V3.0

Parameters [1/12]		
Soft Starter	Setting Factory	Setting Customer
└ Parameter set 1	x	
└ Last changed parameter		
└ [...]¹)		
└ Automatic parameterization		
└ Rated operational current I _e	x ²⁾	
└ Application		
└ Small ventilator	x	
└ No application active		
└ Hydraulic pump		
└ Big ventilator		
└ Milling machine		
└ Conveyor belt		
└ Crusher		
└ Centrifuge		
└ Agitator		
└ Roller conveyor		
└ Pump		
└ Mill		
└ Saw		
└ Compressor		
└ User defined		
└ Advanced parameters		
└ Automatic parameterization		
└ OFF	x	
└ ON - with preset starting time		
└ ON - with preset starting time and current limit		
└ Preset starting time	10 s	
└ Current limiting value	400 %	
└ Application wizard		
└ Small ventilator		
└ Rated operational current I _e	x ²⁾	
└ Starting mode	x ³⁾	
└ Current limiting value	400 %	
└ Starting voltage	40 %	
└ Ramp up time	4 s	
└ Stopping mode	x ⁴⁾	
└ Trip class	CLASS 10E	
└ Big ventilator [...]⁵)		
└ Pump [...]⁵)		
└ Hydraulic pump [...]⁵)		
└ Compressor [...]⁵)		
└ Conveyor belt [...]⁵)		
└ Roller conveyor [...]⁵)		
└ Agitator [...]⁵)		
└ Centrifuge [...]⁵)		
└ Milling machine [...]⁵)		

1) Further menu items

2) Rated operational current I_e of the 3RW55 or 3RW55 Failsafe soft starter used

3) Voltage ramp + Current limiting

4) Coasting down

5) Contains the lower level with settable parameters. Refer to chapter Suggested settings of the application wizard (Page 95).

Parameters [2/12]

Soft Starter	Setting Factory	Setting Customer
└ Mill [...]¹)		
└ Crusher [...]¹)		
└ Saw [...]¹)		
└ User defined [...]¹)		
└ Motor parameters		
└ Rated operational current I _e	x²)	
└ Service factor	1.0	
└ Rated torque	0 Nm	
└ Rated operating speed	1 500 1/min	
└ Type of connection		
└ Automatic detection	x	
└ Standard		
└ Inside-delta		
└ Start settings		
└ Starting mode		
└ Voltage ramp + Current limiting	x	
└ Voltage ramp		
└ Torque control + Current limiting		
└ Torque control		
└ Motor heating		
└ Direct		
└ Starting voltage³)	30 %	
└ Current limiting value³)	400 %	
└ Ramp up time³)	10 s	
└ Maximum starting time³)	0 s	
└ Breakaway time³)	0 s	
└ Breakaway voltage³)	40 %	
└ Starting torque³)		
└ Limiting torque³)		
└ Motor heating power³)		

1) Contains the lower level with settable parameters. Refer to chapter Suggested settings of the application wizard (Page 95).

2) Rated operational current I_e of the 3RW55 or 3RW55 Failsafe soft starter used

3) Display depending on the set Starting mode.

 Parameters [3/12]

Soft Starter	Setting Factory	Setting Customer
└ Stopping mode settings		
└ Stopping mode		
└└ Coasting down		
└└ Voltage ramp	x	
└└ Torque control		
└└ Pump stopping mode		
└└ Reversing DC braking		
└└ Dynamic DC braking		
└└ DC braking		
└ Stopping time ¹⁾	10 s	
└ Stopping torque ¹⁾		
└ Dynamic braking torque ¹⁾		
└ DC braking torque ¹⁾		
└ DC braking delay ¹⁾		
└ Sensorless motor standstill detection ¹⁾		
└ Alternative stopping		
└└ Alternative stopping mode		
└└└ Coasting down	x	
└└└ Voltage ramp		
└└└ Torque control		
└└└ Pump stopping mode		
└└└ Reversing DC braking		
└└└ Dynamic DC braking		
└└└ DC braking		
└└ Alternative stopping time ²⁾		
└└ Alternative stopping torque ²⁾		
└└ Alternative dynamic braking torque ²⁾		
└└ Alternative DC braking torque ²⁾		
└└ Alternative DC braking delay ²⁾		
└ Motor protection		
└└ Electronic motor overload protection		
└└└ Trip class	CLASS 10E	
└└└└ [...]³		
└└ Warning limits		
└└└ Remaining time for tripping	0 s	
└└└ Heating	0 %	
└└ Response to overload thermal motor model		
└└└ Turn off without restart	x	
└└└ Turn off with restart		
└ Recovery time	300 s	
└ Non-volatile tripping status		
└└ Yes	x	
└└ No		

1) Display depending on the set Stopping mode.
 2) Display depending on the set Alternative stopping mode.
 3) Display of the Trip classes.

Parameters [4/12]		
Soft Starter	Setting Factory	Setting Customer
└ Temperature sensor		
└ Sensor type		
└ Deactivated	x	
└ Thermoclick		
└ PTC type A		
└ Response to overload temperature sensor		
└ Turn off without restart	x	
└ Turn off with restart		
└ Warn		
└ Creep speed		
└ Creep speed factor right	7	
└ Creep speed torque right	50 %	
└ Creep speed factor left	7	
└ Creep speed torque left	50 %	
└ Condition Monitoring		
└ Current monitoring		
└ Upper limit		
└ Upper limit - error	0 %	
└ Upper limit - maintenance demanded	0 %	
└ Response to error		
└ Do not turn off	x	
└ Turn off		
└ Lower limit		
└ Lower limit - error	0 %	
└ Lower limit - maintenance demanded	0 %	
└ Response to error		
└ Do not turn off	x	
└ Turn off		
└ Active power monitoring		
└ Reference value	0 W	
└ Upper limit		
└ Upper limit - error	0 %	
└ Upper limit - maintenance demanded	0 %	
└ Response to error		
└ Do not turn off	x	
└ Turn off		
└ Lower limit		
└ Lower limit - error	0 %	
└ Lower limit - maintenance demanded	0 %	
└ Response to error		
└ Do not turn off	x	
└ Turn off		

Parameters [5/12]		
Soft Starter	Setting Factory	Setting Customer
└ Switching frequency monitoring		
└ Mode		
└ Deactivated	x	
└ OFF - ON		
└ ON - ON		
└ Monitoring time 1	0 s	
└ Monitoring time 2	0 s	
└ Maximum number of starts	2	
└ Response to ON-command during active monit. time		
└ Warning with lock-out	x	
└ Warning without lock-out		
└ Turn off without restart		
└ Turn off with restart		
└ Starting time monitoring		
└ Preset starting time	10 s	
└ Upper limit - maintenance demanded	0 %	
└ Lower limit - maintenance demanded	0 %	
└ Pump cleaning		
└ Mode		
└ Deactivated	x	
└ Manual		
└ Time	20 s	
└ Cycles	3	
└ Start/stop parameters		
└ Operating parameters	x	
└ Parameter set 3		
└ Parameter set 2		
└ Parameter set 1		
- Parameter set 2 [...] ¹⁾		
- Parameter set 3 [...] ¹⁾		
- Asymmetry		
└ Limit - warning	0 %	
└ Limit - error	30 %	
- Ground fault		
└ Limit - warning	0 %	
└ Limit - error	20 %	
- Emergency mode		
└ Emergency start		
└ Manually enable/disable		
└ Disable	x	
└ Emergency running ²⁾		
└ Disable	x	
└ Manually enable/disable		
└ Enable		

¹⁾ Further menu items such as Parameter set 1.

²⁾ 3RW5 HMI High Feature from firmware version V3.0

Parameters [6/12]		
Soft Starter	Setting Factory	Setting Customer
- Inputs		
└ Input 1-Action		
└ Motor CW with PS1	x	
└ Motor CCW with PS3		
└ Motor CCW with PS2		
└ Motor CCW with PS1		
└ Operating mode manual - local		
└ No action		
└ Emergency start		
└ Use alternative stopping mode		
└ Reset		
└ Creep speed		
└ Quick-stop		
└ Pump cleaning - mode		
└ Motor standstill		
└ Motor CW with PS3		
└ Motor CW with PS2		
└ Input 2-Action		
└ No action	x	
└ [...]¹)		
└ Input 3-Action		
└ No action	x	
└ [...]¹)		
└ Input 4-Action		
└ Reset	x	
└ [...]¹)		
- Outputs		
└ Digital output 1		
└ Action		
└ On time motor (RUN)	x	
└ Group warning		
└ Group error		
└ Generator operation		
└ Device on		
└ Device error		
└ DC brake contactor		
└ Control source PIQ-DQ-2.0 output 3		
└ Control source PIQ-DQ-1.1 output 2		
└ Control source PIQ-DQ-1.0 output 1		
└ Control source input 4		
└ Control source input 3		
└ Control source input 2		
└ Control source input 1		

¹) Further menu items such as Input 1-Action.

 Parameters [7/12]

Soft Starter	Setting Factory	Setting Customer
└ Control command motor ON		
└ CM - maintenance demanded		
└ CM - error		
└ Bus error		
└ Alternative stopping mode active		
└ Start-up		
└ Run-down		
└ Reversing switching element - right		
└ Reversing switching element - left		
└ Ready to start for motor ON		
└ Pump cleaning active		
└ No action		
└ Operation / Run-down		
└ External bypass ¹⁾		
└ Operation / bypass		
└ ON delay	0 s	
└ OFF delay	0 s	
└ Digital output 2		
└ Action		
└ No action	x	
└ [...]²)		
└ ON delay	0 s	
└ OFF delay	0 s	
└ Digital output 4		
└ Action		
└ Group error	x	
└ [...]²)		
└ ON delay	0 s	
└ OFF delay	0 s	
└ Analog output		
└ Output signal type		
└ Deactivated	x	
└ 4-20 mA		
└ 0-10 V		

1) 3RW5 HMI High Feature from firmware version V2.0

2) Further menu items such as Digital output 1.

Parameters [8/12]		
Soft Starter	Setting Factory	Setting Customer
└ Measured value		
└ Deactivated		
└ Active power		
└ Active energy import total		
└ Switching element heating		
└ Power factor L1...3		
└ Phase current I L3 (rms)		
└ Phase current I L3 (%)		
└ Phase current I L2 (rms)		
└ Phase current I L2 (%)		
└ Phase current I L1 (rms)		
└ Phase current I L1 (%)		
└ Phase current average (rms)		
└ Phase current average (%)		
└ Motor temperature rise		
└ Line voltage U L3-L1 (rms)		
└ Line voltage U L2-L3 (rms)		
└ Line voltage U L1-L2 (rms)		
└ Range start value	0	
└ Range end value	27648	
└ Cyclic send data		
└ Measured value 1		
└ Phase current I L1 (rms)	x	
└ [...]¹)		
└ Measured value 2		
└ Phase current I L2 (rms)	x	
└ [...]¹)		
└ Measured value 3		
└ Phase current I L3 (rms)	x	
└ [...]¹)		
- Ex operation²)		
└ Ex application		
└ Ex-relevant parameters		
- Additional parameters		
└ Operation with CPU / Master		
└ Response to CPU/Master Stop		
└ Switch substitute value	x	
└ Keep last value		

1) Further menu items. Refer to chapter Cyclic send data (Page 207).

2) 3RW5 HMI High Feature from firmware version V2.0



Parameters [9/12]

Soft Starter	Setting Factory	Setting Customer
└ Substitute value		
└ Motor CW	0	
└ Motor CCW	0	
└ Reset	0	
└ Emergency start	0	
└ Creep speed	0	
└ Output 1	0	
└ Output 2	0	
└ Parameter set		
└ Parameter set 1	x	
└ Parameter set 3		
└ Parameter set 2		
└ Disable Quick-stop	0	
└ Output 3	0	
└ Use alternative stopping mode	0	
└ Motor standstill	0	
└ Parameters of CPU/master disabled		
└ Deactivate	x	
└ Activate only for startup parameter		
└ Activate		
└ Response to overload switching element		
└ Turn off without restart	x	
└ Turn off with restart		
└ Response to preset unequal actual configuration of HMI		
└ Ignore	x	
└ Warn		
└ Turn off		
└ Bypass operating mode		
└ Internal bypass	x	
└ No bypass		
└ External bypass without current measurement		
└ Permissible main power rotation		
└ Any	x	
└ Counter-clockw.		
└ Clockwise		
└ Response to faulty main power		
└ Group error only at ON command	x	
└ Warn		
└ Typical ambient temperature	60 °C	
- Date and time		
└ Edit time		
└ Time format	12 h	
└ Time offset	+00:00	
└ Display time		
└ Disable ¹⁾	x	
└ Enable ¹⁾		
└ Edit date		
└ Format of date	MMDDYY	

¹⁾ Display depends on the current setting

Parameters [10/12]		
Communication module	Setting Factory	Setting Customer
- PROFIBUS¹⁾		
└ Station address	126	
└ Baud rate		
- PROFINET²⁾		
└ MAC address		
└ Device name		
└ IP address		
└ Subnet mask		
└ Router address		
- PROFINET HF³⁾		
└ MAC address		
└ Device name		
└ IP address		
└ Subnet mask		
└ Router address		
- Modbus RTU⁴⁾		
└ Server address	126	
└ Baud rate		
└ Port configuration		
└ Access monitoring time	5 s	
└ Silent interval time		
- Detected baud rate⁴⁾		
- Detected port configuration⁴⁾		
- Modbus TCP⁵⁾		
└ MAC address		
└ IP address	192.168.42.99	
└ Subnet mask	255.255.255.15	
└ Router address	0.0.0.0	
└ Access monitoring time	5 s	
- EtherNet/IP⁶⁾		
└ MAC address		
└ IP address setting		
└ IP address		
└ Subnet mask		
└ Router address		
- Group diagnostics^{1), 2), 3)}		
└ Group error ^{1), 2), 3)}		
└ Group warning ^{2), 3)}		
- NTP time synchronization³⁾		
└ Server IP address		
└ Update interval		
- Web server³⁾		
└ [...] ⁷⁾		
- OPC UA server³⁾		
└ [...] ⁷⁾		

- 1) For 3RW5 PROFIBUS communication module
- 2) For 3RW5 PROFINET Standard communication module
- 3) For 3RW5 PROFINET High Feature communication module
- 4) For 3RW5 Modbus RTU communication module
- 5) For 3RW5 Modbus TCP communication module
- 6) For 3RW5 EtherNet/IP communication module
- 7) Further menu items. You will find further information in the equipment manual for the 3RW5 PROFINET communication modules.

Parameters [11/12]		
HMI	Setting Factory	Setting Customer
- Local interface activated ¹⁾	x	
- Local interface deactivated ¹⁾		
- Timer lighting dark	5 min	
- Do control after log off		
└ Continue with motor control		
└ Stop motor and give back control	x	
- Messages to show		
└ Errors		
└ Enable	x	
└ Disable		
└ Warnings		
└ Enable	x	
└ Disable		
- Operation display		
└ Measured value 1		
└ Phase current average (%) ²⁾	x	
└ Measured value 2		
└ Phase current average (rms) ²⁾	x	
└ Measured value 3		
└ Line voltage U L1-L2 (rms) ²⁾	x	
└ Measured value 4		
└ Active power ²⁾	x	
└ Measured value 5		
└ Power factor L1...3 ²⁾	x	
- Edit function favorites		
└ F1 ³⁾		Local / Remote
└ F2 ³⁾		Reset
└ F3 ⁴⁾		
└ F4 ⁴⁾		
└ F5 ⁴⁾		
└ F6 ⁴⁾		
└ F7 ⁴⁾		
└ F8 ⁴⁾		
└ F9 ⁴⁾		
- Configure start key		
└ Control command 1		
└ Motor CW ⁵⁾	x	
└ Control command 2		
└ No start type selected ⁵⁾	x	
└ Control command 3		
└ No start type selected ⁵⁾	x	
└ Control command 4		
└ No start type selected ⁵⁾	x	
- Languages ⁶⁾	English	

¹⁾ Display depends on the current setting

²⁾ Further menu items. Refer to chapter Monitoring the measured values of the 3RW55 soft starter with the 3RW5 HMI High Feature (Page 229).

³⁾ Menu items are permanently set. Refer to chapter Configuring the Function selection key F1-F9 of the 3RW5 HMI High Feature (Page 119).

⁴⁾ Contains the lower level with menu items. Refer to chapter Configuring the Function selection key F1-F9 of the 3RW5 HMI High Feature (Page 119).

⁵⁾ Further menu items. Refer to chapter Configuring the start key of the 3RW5 HMI High Feature (Page 121).

⁶⁾ Contains the lower level with settable languages.

Parameters [12/12]		
Factory settings	Setting Factory	Setting Customer
- Soft Starter		
- Communication module		
- HMI		
- All devices		
Additional information		

Overview [1/1]
Soft Starter
<ul style="list-style-type: none"> - Module <ul style="list-style-type: none"> L Article number L Hardware L Firmware - Module information <ul style="list-style-type: none"> L Tag function L Tag location L Installation date L Additional information - Manufacturer information <ul style="list-style-type: none"> L Manufacturer L Serial number
Communication module
<ul style="list-style-type: none"> - Module <ul style="list-style-type: none"> L Article number L Hardware L Firmware - Manufacturer information <ul style="list-style-type: none"> L Manufacturer L Serial number
HMI
<ul style="list-style-type: none"> - Module <ul style="list-style-type: none"> L Article number L Hardware L Firmware - Manufacturer information <ul style="list-style-type: none"> L Manufacturer L Serial number
Additional information

6.8 Configuring the Function selection key F1-F9 of the 3RW5 HMI High Feature

Security [1/1]
<ul style="list-style-type: none"> - Local access protection <ul style="list-style-type: none"> L Define PIN¹⁾ L Change PIN¹⁾ L Delete PIN¹⁾ L Auto log off time L Log on L Log off - User login - User log off
Additional information

Micro SD card [1/1]
<ul style="list-style-type: none"> - Load parameter settings to soft starter - Save parameter settings to micro SD card - Device change <ul style="list-style-type: none"> - Save trace data to micro SD card²⁾ - Save logbooks to micro SD card - Save service data to micro SD card³⁾ - FW update <ul style="list-style-type: none"> L Soft Starter L HMI L Communication module - Download language²⁾ - Memory space <ul style="list-style-type: none"> L Complete memory L Free memory L Used memory
Additional information

¹⁾ Display depends on the current setting

²⁾ 3RW5 HMI High Feature from firmware version V3.0

³⁾ 3RW5 HMI High Feature from firmware version V2.0

6.8 Configuring the Function selection key F1-F9 of the 3RW5 HMI High Feature

Operating principle

Pressing a Function selection key F1-F9 on the 3RW5 HMI High Feature causes the function stored there to be executed. The function favorites F1 and F2 are permanently assigned the functions "Local/Remote" and "Reset". The function favorites F3 to F9 can be parameterized by assigning further functions to them.

Setting options

- 3RW5 HMI High Feature
Menu: "Parameters > HMI > Edit function favorites"
Access protection to the 3RW5 HMI High Feature is not active or has been reset.
- With SIRIUS Soft Starter ES (TIA Portal) via the local interface on the 3RW5 HMI High Feature
Brief overview: Window "Project Navigation" with current project under created Soft Starter > "Parameters" > Window "Work area" > "HMI > Edit function favorites"
- With a fieldbus via a 3RW5 communication module:
 - With SIRIUS Soft Starter ES (TIA Portal) Premium / Professional (only via a 3RW5 PROFINET or PROFIBUS communication module)
Brief overview: See SIRIUS Soft Starter ES (TIA Portal) via the local interface on the 3RW5 HMI High Feature
 - Configuration software of the control system (e.g. STEP 7 with corresponding HSP)
 - User program

You can find additional information on the parameters that can be set via the fieldbus in the manual of the respective 3RW5 communication module.

Procedure for configuration on the 3RW5 HMI High Feature

1. Press the Function selection key F1-F9 on the 3RW5 HMI High Feature and choose menu item "Edit function favorites". Confirm by pressing the OK key.
Alternatively via menu: "Parameters > HMI > Edit function favorites"
2. Select the Function favorites F3 to F9 and confirm with the OK key.
The Function selection menu appears on the display.
3. Select the desired function and confirm with the OK key.

Parameters

Parameters		Description
F1 - Local/Remote ¹⁾		Changes master control
F2 - Reset		Acknowledges faults
Edit function favorites	F3 ... F9	Menu for Function selection F1 ... F9: <ul style="list-style-type: none"> • No function • Motor CCW - creep speed²⁾ • Motor CCW • Motor CW - creep speed²⁾ • Motor CW • Start pump cleaning • Select parameter set³⁾ • Alternative stopping mode • Quick-stop • Save logbooks to micro SD card • Save parameter settings to micro SD card • Creep speed²⁾ • Emergency start³⁾ • Emergency run^{2), 3), 4)} • Local/Remote (permanent setting F1) • Reset (permanent setting F2)

¹⁾ Display depends on the current setting

²⁾ Not available with the 3RW55 Failsafe soft starter

³⁾ Not available for Ex operation

⁴⁾ 3RW5 HMI High Feature from firmware version V3.0

Result

You have reassigned the function favorites F3 ... F9.

6.9 Configuring the start key of the 3RW5 HMI High Feature

Operating principle

You can assign up to 4 different start functions to the start key of the 3RW5 HMI High Feature. In the factory setting, the start function "Motor CW" is assigned to the start key. If the start key is configured and then pressed, this opens the parameterized start functions in a pop-up window. They can then be selected by means of the navigation keys and activated with the "OK" key.

6.9 Configuring the start key of the 3RW5 HMI High Feature

Setting options

- 3RW5 HMI High Feature
Menu: You are in menu "Parameters > HMI > Configure start key".
Access protection to the 3RW5 HMI High Feature is not active or has been reset.
- With SIRIUS Soft Starter ES (TIA Portal) via the local interface on the 3RW5 HMI High Feature
Brief overview: Window "Project Navigation" with current project under created Soft Starter > "Parameters" > Window "Work area" > "HMI > Configure start key"
- With a fieldbus via a 3RW5 communication module:
 - With SIRIUS Soft Starter ES (TIA Portal) Premium / Professional (only via a 3RW5 PROFINET or PROFIBUS communication module)
Brief overview: See SIRIUS Soft Starter ES (TIA Portal) via the local interface on the 3RW5 HMI High Feature
 - Configuration software of the control system (e.g. STEP 7 with corresponding HSP)
 - User program

You can find additional information on the parameters that can be set via the fieldbus in the manual of the respective 3RW5 communication module.

Master control function of the 3RW5 HMI High Feature

Note the information in chapter Design and operator controls of the High Feature 3RW5 HMI (Page 100).

Procedure for configuration on the 3RW5 HMI High Feature

1. In the "Configure start key" menu, select the required start function and confirm with the OK key.
You can assign as many as 4 start functions to the start key.
2. Press the start key.
You receive a list of all the assigned start functions.
3. Select the required start function and confirm with the OK key.
The selected start function is executed.

Parameters

Parameters	Description
Motor CW (factory setting)	Motor turns clockwise
Motor CW - creep speed ^{1), 2)}	Motor turns clockwise with active creep speed
Motor CCW ¹⁾	Motor turns counter-clockwise
Motor CCW - creep speed ^{1), 2)}	Motor turns counter-clockwise with active creep speed

¹⁾ This control command is only available in conjunction with the activated function "Creep speed" or "Reversing operation".

²⁾ Function is not available for the 3RW55 Failsafe soft starter.

Result

As many as 4 start functions have been assigned to the start key. These functions can be selected and executed after actuating the start key.

6.10 Parameterizing the 3RW5 HMI High Feature

Setting options

- 3RW5 HMI High Feature
Menu: "Parameters > HMI"
Access protection to the 3RW5 HMI High Feature is not active or has been reset.
- With SIRIUS Soft Starter ES (TIA Portal) via the local interface on the 3RW5 HMI High Feature
Brief overview: Window "Project Navigation" with current project under created Soft Starter > "Parameters" > Window "Work area" > "HMI"
- With a fieldbus via a 3RW5 communication module:
 - With SIRIUS Soft Starter ES (TIA Portal) Premium / Professional (only via a 3RW5 PROFINET or PROFIBUS communication module)
Brief overview: See SIRIUS Soft Starter ES (TIA Portal) via the local interface on the 3RW5 HMI High Feature
 - Configuration software of the control system (e.g. STEP 7 with corresponding HSP)
 - User program

You can find additional information on the parameters that can be set via the fieldbus in the manual of the respective 3RW5 communication module.

Parameter

Parameters	Description
Local interface activated (via 3RW5 HMI High Feature only)	The parameter is only visible if the local interface is enabled (factory setting). Disables the local interface of the 3RW5 HMI High Feature. Before you can connect a PC with SIRIUS Soft Starter ES (TIA Portal) and the 3RW55 or 3RW55 Failsafe soft starter via the local interface, the local interface must be enabled. You can prevent unauthorized access via SIRIUS Soft Starter ES (TIA Portal) by disabling the local interface.
Local interface deactivated (via 3RW5 HMI High Feature only)	The parameter is only visible if the local interface is disabled. Enables the local interface of the 3RW5 HMI High Feature.
Timer lighting dark	If no keys on the 3RW5 HMI High Feature are pressed, the display will shut down after a specified time period has elapsed. The setting "0 min" deactivates shutdown of the display. <ul style="list-style-type: none"> • Factory setting: 5 min • Setting range: 0 ... 60 min • In steps of: 1 min

6.10 Parameterizing the 3RW5 HMI High Feature

Parameters	Description
Do control after log off	<p>This parameter describes the response after logging off while the motor is running.</p> <ul style="list-style-type: none"> • Continue with motor control Control is retained by the 3RW5 HMI High Feature. • Stop motor and give back control (factory setting) The motor stops and the master control is no longer with the 3RW5 HMI High Feature. Refer to chapter Operating modes and master control function (Page 34).
Messages to show	<p>If errors and/or warnings are enabled, they will appear as pop-up windows in the display of the 3RW5 HMI High Feature as soon as they occur.</p> <ul style="list-style-type: none"> • Error <ul style="list-style-type: none"> – Enable (factory setting) – Disable • Warnings <ul style="list-style-type: none"> – Enable (factory setting) – Disable
Operation display	<p>You can select up to 5 different measured values from a list of measured values. These measured values are then shown in the operation display of the 3RW5 HMI High Feature. You will find further information on measured values in chapter Monitoring the measured values of the 3RW55 soft starter with the 3RW5 HMI High Feature (Page 229).</p> <ul style="list-style-type: none"> • Phase current average (%) (factory setting) • Phase current average (rms) (factory setting) • Line voltage U L1-L2 (rms) (factory setting) • Active power (factory setting) • Power factor L1...3 (factory setting)
Edit function favorites	<p>Setting the function selection menu F1-F9. You will find more information in chapter Configuring the Function selection key F1-F9 of the 3RW5 HMI High Feature (Page 119).</p>
Configure start key	<p>Setting the start key You will find more information in chapter Configuring the start key of the 3RW5 HMI High Feature (Page 121).</p>
Language	<p>The required language is set in the "Language" menu.</p> <ul style="list-style-type: none"> • English (factory setting) • German • French • Spanish • Italian • Portuguese • Chinese • Additional language¹⁾ (Page 247)

¹⁾ Only visible if an additional language has been added.

6.11 Parameterizing the 3RW55 or 3RW55 Failsafe soft starter in series / identically

6.11.1 Parameterizing the 3RW55 or 3RW55 Failsafe soft starter with micro SD card in series / identically

If you want to parameterize multiple 3RW55 or 3RW55 Failsafe soft starters identically, you can parameterize them serially with a micro SD card.

Requirements

- Micro SD card (Page 245)

Procedure

1. Parameterize the 3RW55 or 3RW55 Failsafe (Page 91) soft starter and the 3RW5 HMI High Feature (Page 123).
2. Plug the micro SD card into the 3RW5 HMI High Feature.
3. Load the parameters onto the micro SD card.
Menu: "Micro SD card > Save parameter settings to micro SD card"
Example of a folder name created on the micro SD card: "1P3RW5 xxx-xxxxx"
Note the information in chapter Micro SD card (Page 245).
4. Remove the micro SD card from the 3RW5 HMI High Feature.
5. Insert the micro SD card into the 3RW5 HMI High Feature on the 3RW55 or 3RW55 Failsafe soft starter that you want to parameterize identically to the original 3RW55 or 3RW55 Failsafe soft starter.
6. Load the parameters onto the new 3RW55 or 3RW55 Failsafe soft starter.
Menu: "Micro SD card > Load parameter settings to soft starter"
Note the information in chapter Micro SD card (Page 245).
7. Complete the parameter settings. Parameters that are not transferred include I&M data (Page 236) and communication parameters, for example. If you want to include the communication parameters in the transfer, please note the information on the "Device change" function (Page 283).
8. If you wish, repeat the procedure for further 3RW55 or 3RW55 Failsafe soft starters.

Result

You have parameterized multiple 3RW55 or 3RW55 Failsafe soft starters identically.

6.11.2 Parameterizing the 3RW55 or 3RW55 Failsafe soft starter in series / identically with SIRIUS Soft Starter ES (TIA Portal)

If you want to parameterize multiple 3RW55 or 3RW55 Failsafe soft starters identically, you can parameterize them in series with SIRIUS Soft Starter ES (TIA Portal).

Requirements

- SIRIUS Soft Starter ES (TIA Portal)

Procedure

1. Parameterize the 3RW55 or 3RW55 Failsafe soft starter and the 3RW5 HMI High Feature in SIRIUS Soft Starter ES (TIA Portal).
 - Brief overview: Window "Project Navigation" with current project under created Soft Starter > "Parameters" > Window "Work area" > "Soft Starter"
 - Brief overview: Window "Project Navigation" with current project under created Soft Starter > "Parameters" > Window "Work area" > "HMI"
2. Save the project.
3. Disconnect the link to the 3RW55 or 3RW55 Failsafe soft starter.
4. Connect the 3RW55 or 3RW55 Failsafe soft starter for which you want to set new parameters to the SIRIUS Soft Starter ES (TIA Portal).
5. Transfer the data to the 3RW55 or 3RW55 Failsafe soft starter.
Button: "Download to device" on the toolbar.
In the "Project Navigation" window, the 3RW55 or 3RW55 Failsafe soft starter must be selected in the current project so that the button can be operated. The 3RW55 or 3RW55 Failsafe soft starter must not be connected online to SIRIUS Soft Starter ES (TIA Portal).
6. If you wish, repeat the procedure for further 3RW55 or 3RW55 Failsafe soft starters.

Result

You have parameterized multiple 3RW55 or 3RW55 Failsafe soft starters identically.

Commissioning

7.1 Commissioning 3RW55 and 3RW55 Failsafe soft starters

Procedure

1. Mount the 3RW55 or 3RW55 Failsafe (Page 57) soft starter.
2. Connect the 3RW55 or 3RW55 Failsafe soft starter (Page 76).
3. Set the required language, the current date and time and the rated operational current. First commissioning of the High Feature 3RW5 HMI (Page 129)
4. Parameterize the 3RW55 or 3RW55 Failsafe soft starter for your application (Page 91). For support, use the application wizard (Page 94) and automatic parameterization (Page 134).
5. Conduct a test of the application in test mode (Page 223).
6. Optionally, you can run diagnostics (Page 260) including Self-test (user-test) (Page 267) to test correct functioning of the 3RW55 or 3RW55 Failsafe soft starter.
7. Set the access protection (optional).
 - Local access protection (PIN) (Page 239)
 - User login and logout (Page 244)
 - Sealing 3RW55 and 3RW55 Failsafe soft starters (optional) (Page 128)

Note

Last changed parameters

For each parameter set, you can view and directly modify the last 10 changed parameters.

Menu: "Parameters > Soft Starter > Parameter set 1 / 2 / 3 > Last changed parameter"

Result

The 3RW55 or 3RW55 Failsafe soft starter is ready for operation and protected from external access.

You will find additional information on operating modes and the respective control priority in chapter Operating modes and master control function (Page 34).

7.2 Sealing 3RW55 and 3RW55 Failsafe soft starters (optional)

Requirements

- Seal, sealing wire and a suitable sealing tool

Procedure

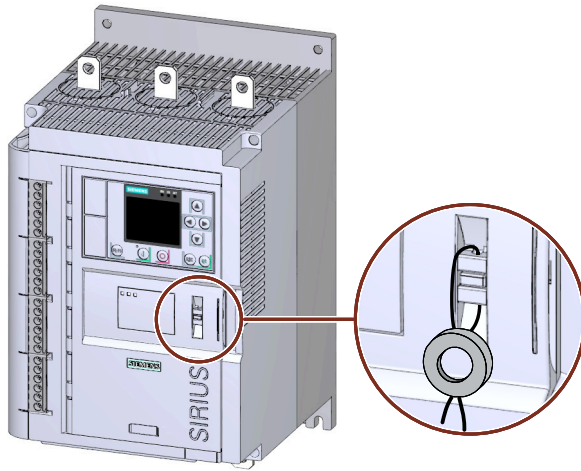

Illustration similar

1. Push the wire through the openings provided.
2. Seal the wire to secure the hinged cover against unauthorized opening.

Result

By sealing the hinged cover, the interface cover of the 3RW5 HMI High Feature is protected against unauthorized access. In addition, the 3RW5 HMI High Feature and the 3RW5 communication module (where present) are protected against unauthorized removal. It is still possible to operate the 3RW5 HMI High Feature.

Tip

If you install the 3RW5 HMI High Feature outside of the 3RW55 or 3RW55 Failsafe soft starter, use an anti-tamper seal on the interface cover to protect the local interface and the slot of the micro SD card from unauthorized access. Proceed in the same sequence as for sealing the spring flap.

You will find more information in chapter Design and operator controls of the High Feature 3RW5 HMI (Page 100).

7.3 First commissioning of the High Feature 3RW5 HMI

Requirements

- Power supply (control supply voltage) is connected for the first time or the factory settings have been restored on the 3RW5 HMI High Feature.
- Design and operator controls of the High Feature 3RW5 HMI (Page 100)

Procedure

1. Select the desired language and confirm with the OK key.
2. Set the date and time and confirm the menu after setting the parameters with the right-hand navigation key.
You can use the left-hand navigation key to switch back to language selection.
3. Save the settings by confirming one of the three following menu entries with the OK key or exit the menu without saving the settings ("Don't save startup parameters and exit").
 - "Save startup parameters and start application wizard"
The 3RW5 HMI High Feature switches to the application wizard (Page 94) menu.
 - "Save startup parameters and start automatic parameterization"
The 3RW5 HMI High Feature switches to the automatic parameterization (Page 134) menu.
 - "Save startup parameters and exit"
The 3RW5 HMI High Feature switches to the operation display.

Result

The 3RW5 HMI High Feature is ready to use. You will find an overview of the functions in chapter 3RW5 HMI High Feature (Page 30). Note the menu structure in chapter Menu of the 3RW5 HMI High Feature (Page 101).

Functions

Overview of the described functions

Function	Soft Starter	
	3RW55	3RW55 Failsafe
Parameter sets (Page 93)	x	x
Application wizard (Page 94)	x	x
Motor parameters (Page 97)	x	x
Startup (Page 133)	x	x
Automatic parameterization (Page 134)	x	x
Soft starting with voltage ramp (Page 136)	x	x
Soft starting with torque control (Page 139)	x	x
Soft starting with voltage ramp and current limiting (Page 142)	x	x
Soft starting with torque control and current limiting (Page 144)	x	x
Direct start (Page 145)	x	x
Motor heating (Page 145)	x	-
Breakaway pulse (Page 146)	x	x
Run-down (Page 148)	x	x
Coasting down (Page 150)	x	x
Voltage ramp (Page 151)	x	x
Torque control (Page 152)	x	x
Pump stopping mode (Page 154)	x	x
DC braking (Page 156)	x	-
DC braking with external braking contactors (Page 156)	x	-
Dynamic DC braking without contactor (Page 159)	x	-
Reversing DC braking with a reversing contactor assembly (Page 162)	x (from firmware version V2.0)	-
Sensorless motor standstill detection (Page 164)	x (from firmware version V2.0)	-
External motor standstill detection (Page 165)	x	-
Alternative stopping (Page 165)	x	x
Motor protection (Page 168)	x	x
Complete motor protection (Page 168)	x	x
Electronic motor overload protection (Page 168)	x	x
Temperature sensor (Page 171)	x	x
Intrinsic device protection (Page 173)	x	x
Creep speed (Page 174)	x	-

Function	Soft Starter	
	3RW55	3RW55 Failsafe
Reset (Page 175)	x	x
Quick-stop (Page 176)	x	x
Condition monitoring (Page 176)	x	x
Current monitoring (Page 177)	x	x
Active power monitoring (Page 179)	x	x
Switching frequency monitoring (Page 180)	x	x
Starting time monitoring (Page 183)	x	x
Pump cleaning function (Page 184)	x	x
Asymmetry (Page 188)	x	x
Ground fault (Page 189)	x	x
Emergency mode (Page 191)	x	x
Emergency start (Page 191)	x	x
Emergency run (Page 193)	x (from firmware version V2.1)	-
Inputs (Page 196)	x	x
Input actions (Page 196)	x	x
Process data and process images (Page 198)	x	x
Outputs (Page 200)	x	x
Digital outputs (Page 200)	x	x
Analog output (Page 204)	x	x
Cyclic send data (Page 207)	x	x
ATEX/IECEX/UKEX (Page 208)	x (from product version E02 and firmware version V2.0)	x
Failsafe (Page 214)	-	x
Functions under "Additional parameters" (Page 216)	x	x
Date and time (Page 220)	x	x
Trace (Page 222)	x	x
Test mode (Page 223)	x	x
Test with small load (Page 224)	x	x
Simulation (Page 226)	x (from firmware version V2.1)	-
Monitoring (Page 229)	x	x
Control (Page 234)	x	x
Overview (Page 236)	x	x
Local access protection and user account administration (Page 239)	x	x
Micro SD card (Page 245)	x	x
Self-test (user-test) (Page 267)	x	x
Logbooks (Page 268)	x	x
Service data (Page 269)	x	x
Firmware update (Page 277)	x	x

Function	Soft Starter	
	3RW55	3RW55 Failsafe
Factory setting (Page 280)	x	x
Device change (Page 283)	x	x

8.1 Start-up

8.1.1 Starting modes

Operating principle

The starting mode of the 3RW55 and 3RW55 Failsafe soft starters determines how the motor is ramped up after the start command. You can set various starting modes.

Setting options

- 3RW5 HMI High Feature
Menu: "Parameters > Soft Starter > Parameter set 1 / 2 / 3 > Start settings > Starting mode"
Access protection to the 3RW5 HMI High Feature is not active or has been reset.
- With SIRIUS Soft Starter ES (TIA Portal) via the local interface on the 3RW5 HMI High Feature
Brief overview: Window "Project Navigation" with current project under created Soft Starter > "Parameters" > Window "Work area" > "Soft Starter > Parameter set 1 / 2 / 3 > Start settings"
- With a fieldbus via a 3RW5 communication module:
 - With SIRIUS Soft Starter ES (TIA Portal) Premium / Professional (only via a 3RW5 PROFINET or PROFIBUS communication module)
Brief overview: See SIRIUS Soft Starter ES (TIA Portal) via the local interface on the 3RW5 HMI High Feature
 - Configuration software of the control system (e.g. STEP 7 with corresponding HSP)
 - User program

You can find additional information on the parameters that can be set via the fieldbus in the manual of the respective 3RW5 communication module.

Starting modes of the 3RW55 and 3RW55 Failsafe soft starters

- Soft starting with voltage ramp (Page 136)
- Soft starting with torque control (Page 139)
- Soft starting with voltage ramp and current limiting (Page 142)
(Factory setting)
- Soft starting with torque control and current limiting (Page 144)

- Direct-on-line starting (Page 145)
- Motor heating (Page 145)
This starting mode is not available for the 3RW55 Failsafe soft starter.

Breakaway pulse

In connection with the 4 soft starting modes, you can set an advance breakaway pulse (Page 146).

Tip

The Automatic parameterization (Page 134) supports you during commissioning and optimizes the starting parameters of the 3RW55 and 3RW55 Failsafe soft starters each time the motor is started.

8.1.2 Automatic parameterization

Operating principle

When automatic parameterization is activated, the 3RW55 or 3RW55 Failsafe soft starter optimizes the starting parameters each time the motor is started. The recommended parameters of the selected application are automatically accepted as the start value for automatic parameterization.

For the PRESET starting time the ramp-up time is adopted as the start value and, for the current limiting, the preset value of the application. The parameters are selected in such a way that the motor starts immediately with minimum current and does not falter during start-up. Automatic parameterization can be set for each of the parameter sets.

Adjustment of the parameters with automatic parameterization

As long as the "Automatic parameterization" function is active, the 3RW55 or 3RW55 Failsafe soft starter monitors and analyzes the starting times and the starting currents at every start up.

The 3RW55 or 3RW55 Failsafe soft starter always sets the selected starting mode to "Soft starting with voltage ramp and current limiting (Page 142)". If another starting mode is required, deactivate the automatic parameterization and modify the corresponding parameters.

The following parameters are also changed by the automatic parameterization and therefore learned:

- Starting voltage
- Ramp up time
- Current limiting value

All further parameters are unaffected by the activated automatic parameterization and can still be parameterized. In this way, parameters, such as Starting mode or breakaway pulse, can be set independently of the Automatic parameterization.

Interaction with use of a 3RW5 communication module

To prevent the learned parameters from being overwritten by the starting parameters of the higher-level control on each system restart, activate the parameter "Parameters of CPU/master disabled" (Page 216).

You can find further information on the parameter "Parameters of CPU/master disabled" in the manual for the respective 3RW5 communication module.

Setting via 3RW5 HMI High Feature

- Menu: "Parameters > Soft Starter > Parameter set 1 / 2 / 3 > Automatic parameterization"
- Access protection to the 3RW5 HMI High Feature is not active or has been reset.

Procedure

To activate the Automatic parameterization, you must define the parameters "Rated operational current I_e " and "Application":

1. Set the rated operational current I_e of the motor connected to the 3RW55 or 3RW55 Failsafe soft starter.
If you have not yet set the rated operational current I_e of the motor, the 3RW55 or 3RW55 Failsafe soft starter uses the stored value of the factory setting. After the automatic parameterization has been activated, an input prompt pops up for the rated operational current I_e of the motor.
2. Choose the desired application with the menu item "Application".
3. If necessary, set the parameters "Mode", "Preset starting time" and "Current limiting value-maximum".
4. Exit the menu for Automatic parameterization with the ESC key. Confirm the query "Save parameter?" with the OK key.

Parameters

Parameters	Description
Rated operational current I_e	Depending on the rated operational current I_e of the motor connected to the 3RW55 or 3RW55 Failsafe soft starter.
Application	Selection of all supported applications. When selecting the application, the recommended start values for the parameters "Preset starting time" and "Current limiting value - maximum" are used, depending on the application. You can find these values in the "Advanced parameters" menu. Change these values as required. The recommended application parameters for the first start of the automatic parameterization are rough values for guidance. Change these values as required.
Advanced parameters	

8.1 Start-up

Mode	Select the mode depending on the selected application, depending on whether current limiting is recommended or not. You can change the mode manually at any time.
	Off (factory setting) The function is deactivated.
	On - with preset starting time The motor should have reached the rated operating speed after a specified starting time.
	On - with preset starting time and current limiting The motor should reach the rated operating speed after a specified starting time if the current value is limited.
Preset starting time (Identical to the parameter of the Starting time monitoring (Page 183))	<p>The time after which the motor should have reached its rated operating speed.</p> <p>With the setting "0 s", there is no automatic parameterization.</p> <p>For the PRESET starting time the ramp-up time is adopted as the start value. Change the preset values as required.</p> <ul style="list-style-type: none"> • Factory setting: 4 s • Setting range: 0 ... 360 s • In steps of: 0.1 s
Current limiting value - maximum	<p>This parameter only takes effect in connection with the parameter "Mode" (On - with preset starting time and current limiting).</p> <p>Depending on the selected application, the corresponding preset values are used for this parameter. Change the preset values as required.</p> <ul style="list-style-type: none"> • Factory setting: 400% • Setting range: 125 ... 800% • In steps of: 1%

Result

Once the parameters have been stored, you can view the automatically determined values in the parameter settings of the respective parameter set. If you deactivate automatic parameterization, the stored values are no longer modified. The parameters learned in the 3RW55 or 3RW55 Failsafe soft starter are only overwritten if the device is parameterized again.

Deactivating automatic parameterization

To deactivate automatic parameterization, set the parameter "Mode" to "OFF".

8.1.3 Soft starting with voltage ramp

Operating principle

A voltage ramp is used to implement soft starting. The 3RW55 or 3RW55 Failsafe soft starter increases the motor voltage from a parameterizable starting voltage to the line voltage within a definable ramp-up time.

Application

- E.g. pumps or small fans

Setting via 3RW5 HMI High Feature

- Menu: "Parameters > Soft Starter > Parameter set 1 / 2 / 3 > Start settings > Starting mode > Voltage ramp"
- Menu (Parameters): "Parameters > Soft Starter > Parameter set 1 / 2 / 3 > Start settings"
- Access protection to the 3RW5 HMI High Feature is not active or has been reset.

Voltage characteristic

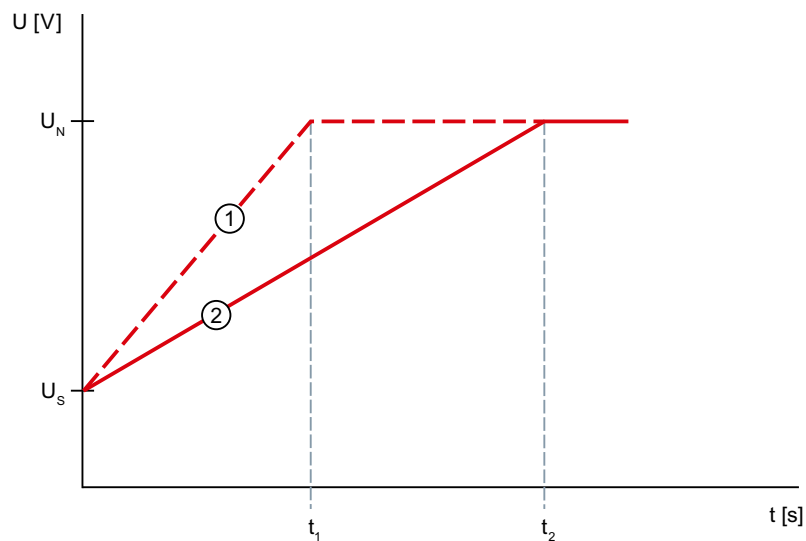

- ① Voltage ramp with short ramp-up time t_1
- ② Voltage ramp with long ramp-up time t_2
- U_N Line voltage
- U_s Parameterizable starting voltage
- t_1 Short ramp-up time
- t_2 Long ramp-up time

Torque curve

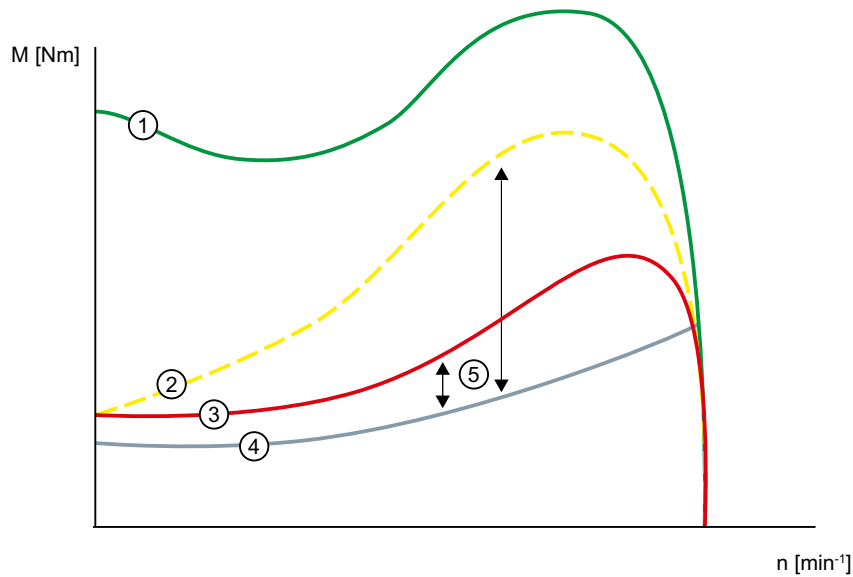

- ① Torque with direct-on-line starting without 3RW55 or 3RW55 Failsafe soft starter
- ② Torque with short ramp-up time
- ③ Torque with long ramp-up time
- ④ Torque of the load
- ⑤ Acceleration torque = Difference between activation torque and torque of load

Current characteristic

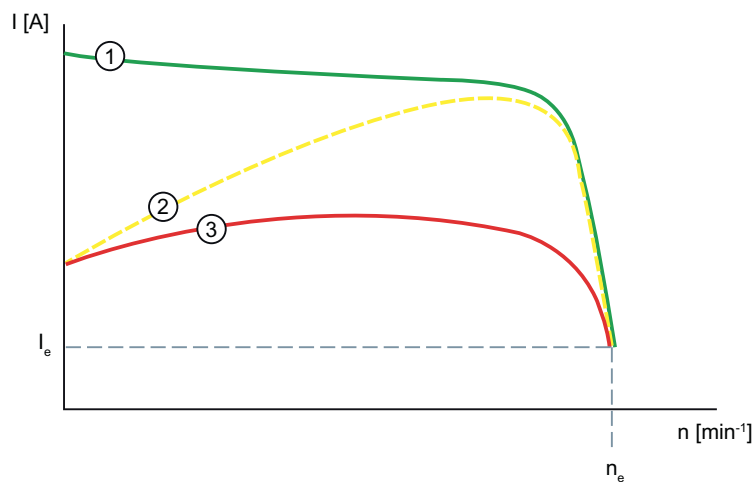

- ① Current characteristic with direct-on-line starting without 3RW55 or 3RW55 Failsafe soft starter
- ② Current characteristic with short ramp-up time
- ③ Current characteristic with long ramp-up time
- I_e Rated operational current during rated operation
- n_e Rated operating speed of the motor

Parameters

Parameters	Description
Starting voltage	<p>The starting voltage determines the starting torque of the motor. A lower starting voltage results in a lower switch-on torque and a lower starting current. Select a starting voltage that is high enough to ensure that the motor starts up immediately and smoothly when the start command is issued to the 3RW55 or 3RW55 Failsafe soft starter.</p> <ul style="list-style-type: none"> • Factory setting: 30% • Setting range: 20 ... 100% • In steps of: 5%
Ramp up time	<p>The ramp-up time determines the time taken to increase the motor voltage from the parameterized starting voltage to the line voltage. This has an influence on the motor's acceleration torque which drives the load during start-up. A longer ramp-up time results in a shorter acceleration torque across the motor ramp-up time. The motor runs up longer and more softly. Set the ramp-up time so that the motor can reach its rated operating speed by the time the end of the ramp-up is reached. The actual motor starting time is load-dependent and can differ from the parameterized ramp-up time.</p> <p>If you choose a time that is too short, the ramp-up time ends before the motor has accelerated to speed. A very high starting current that can reach the value of the direct starting current at this speed then occurs. In this case, the 3RW55 and 3RW55 Failsafe soft starters can switch themselves off via the internal overload protection function and signal a fault.</p> <p>With the setting "0 s", the motor is switched on with a ramp-up time of approx. 100 ms.</p> <ul style="list-style-type: none"> • Factory setting: 10 s • Setting range: 0 ... 360 s • In steps of: 0.1 s
Maximum starting time	<p>This time determines the period after which the drive must have completed its start-up. If the drive is not yet operating under rated conditions after the specified interval has expired, the generalized phase control of the thyristors is interrupted and the line voltage is raised to 100%. The setting "0 s" deactivates the maximum starting time.</p> <p>Maximum starting time \geq ramp-up time.</p> <ul style="list-style-type: none"> • Factory setting: 0 s • Setting range: 0 ... 1 000 s • In steps of: 0.1 s
Breakaway time	See Breakaway pulse for startup functions (Page 146)
Breakaway voltage	

8.1.4 Soft starting with torque control

Operating principle

Torque control means that the torque generated in the motor is linearly increased from a parameterizable starting torque up to a parameterizable end torque within an adjustable starting time.

The advantage over a voltage ramp is the improved mechanical run-up behavior of the machine. The 3RW55 and 3RW55 Failsafe soft starters control the torque generated at

the motor continuously and linearly according to the set parameters until the motor has completed its run-up.

For optimum torque control during the starting procedure, enter the motor data of the motor connected to the 3RW55 or 3RW55 Failsafe soft starter in the selected parameter set.

Application

- E.g. conveyor belts

Setting via 3RW5 HMI High Feature

- Menu: "Parameters > Soft Starter > Parameter set 1 / 2 / 3 > Start settings > Starting mode > Torque control"
- Menu (Parameters): "Parameters > Soft Starter > Parameter set 1 / 2 / 3 > Start settings"
- Access protection to the 3RW5 HMI High Feature is not active or has been reset.

Torque curve

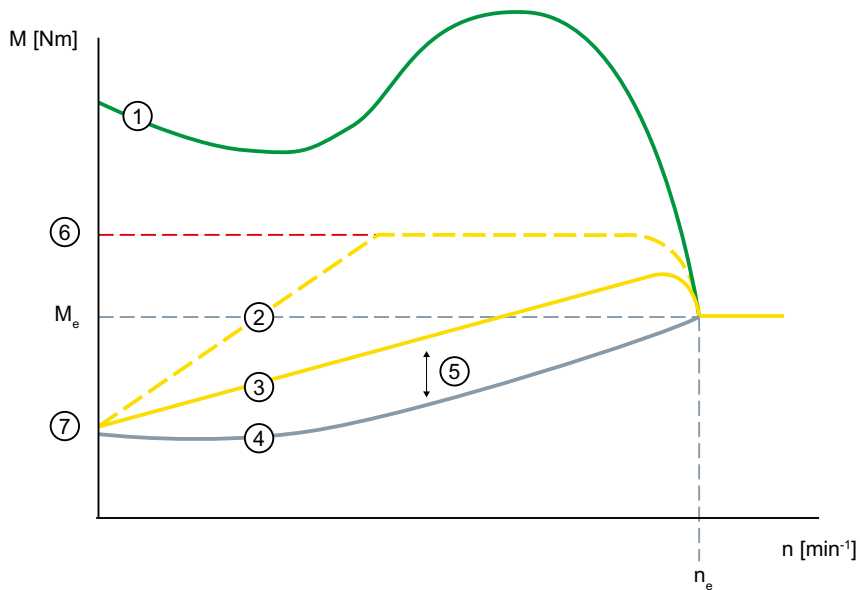

- ① Torque with direct-on-line starting without 3RW55 or 3RW55 Failsafe soft starter
- ② Torque with short ramp-up time
- ③ Torque with long ramp-up time
- ④ Torque of the load
- ⑤ Acceleration torque = Difference between activation torque and torque of load
- ⑥ Parameterizable limiting torque
- ⑦ Parameterizable starting torque
- M_e Rated torque
- n_e Rated operating speed of the motor

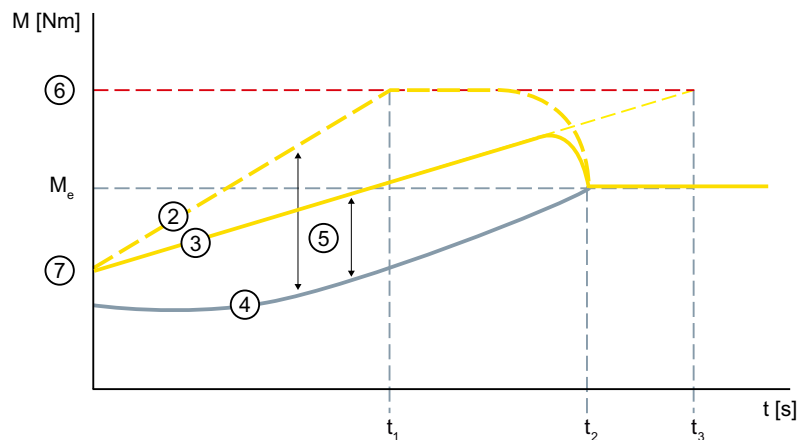

- ② Torque with short ramp-up time
- ③ Torque with long ramp-up time
- ④ Torque of the load
- ⑤ Acceleration torque = Difference between activation torque and torque of load
- ⑥ Parameterizable limiting torque
- ⑦ Parameterizable starting torque
- t_1 Parameterizable ramp-up time
- t_2 Motor has started up and is in rated operation. The start-up is detected and the bypass contacts close
- t_3 Parameterizable ramp-up time
- M_e Rated torque

Parameters

Parameters	Description
Starting torque	<p>The magnitude of the starting torque determines the switch-on torque of the motor. A lower starting torque results in a lower switch-on torque and a lower starting current.</p> <p>Select a starting torque that is high enough to ensure that the motor starts immediately and smoothly when the start command is issued to the 3RW55 or 3RW55 Failsafe soft starter. The rated torque of the motor is used as the reference value.</p> <ul style="list-style-type: none"> • Factory setting: 10% • Setting range: 10 ... 100% • In steps of: 5%
Limiting torque	<p>The limiting torque value specifies the maximum torque to be generated in the motor during start-up. This value also functions as an adjustable torque limit.</p> <p>The parameter value should be set to approx. 150% to start the motor. It should be high enough to ensure that the motor does not falter during start-up. This ensures that enough acceleration torque is generated throughout the motor run-up phase. The rated torque of the motor is used as the reference value.</p> <p>Limiting torque \geq starting torque</p> <ul style="list-style-type: none"> • Factory setting: 150% • Setting range: 20 ... 200 % • In steps of: 5%

8.1 Start-up

Ramp up time	<p>The ramp-up time determines the time in which the starting torque is increased to the limiting torque. This has an influence on the motor's acceleration torque which drives the load during start-up. A longer ramp-up time results in a shorter acceleration torque across the motor ramp-up time. The motor runs up longer and more softly.</p> <p>The actual motor starting time is load-dependent and can differ from the parameterized ramp-up time. If the starting time ends before the motor has completely ramped up, the torque is limited to the set limiting torque until the 3RW55 or 3RW55 Failsafe soft starter detects that the motor has ramped up and closes the internal bypass contacts.</p> <p>With the setting "0 s", the motor is switched on with a ramp-up time of approx. 100 ms.</p> <ul style="list-style-type: none"> • Factory setting: 10 s • Setting range: 0 ... 360 s • In steps of: 0.1 s
Maximum starting time	<p>This time determines the period after which the drive must have completed its start-up. If the drive is not yet operating under rated conditions after the specified interval has expired, the generalized phase control of the thyristors is interrupted and the line voltage is raised to 100%. The setting "0 s" deactivates the maximum starting time.</p> <p>Maximum starting time \geq ramp-up time.</p> <ul style="list-style-type: none"> • Factory setting: 0 s • Setting range: 0 ... 1 000 s • In steps of: 0.1 s
Breakaway time	See Breakaway pulse for startup functions (Page 146)
Breakaway voltage	

8.1.5 Soft starting with voltage ramp and current limiting

Operating principle

Select the starting mode "Voltage ramp + Current limiting" if, at the same time as protecting the system during startup, you want to ensure that a specific current value is not exceeded during motor starting. The motor is always started up with the voltage ramp. If the current exceeds the parameterized current limit, the voltage ramp is aborted and the current limitation function starts. The current limitation function remains active until the 3RW55 or 3RW55 Failsafe soft starter detects that the motor has ramped up and the motor is in a normal operating state.

Application

- Avoiding current surges
- Reducing energy costs

Setting via 3RW5 HMI High Feature

- Menu: "Parameters > Soft Starter > Parameter set 1 / 2 / 3 > Start settings > Starting mode > Voltage ramp + Current limiting"
- Menu (Parameters): "Parameters > Soft Starter > Parameter set 1 / 2 / 3 > Start settings"
- Access protection to the 3RW5 HMI High Feature is not active or has been reset.

Current characteristic

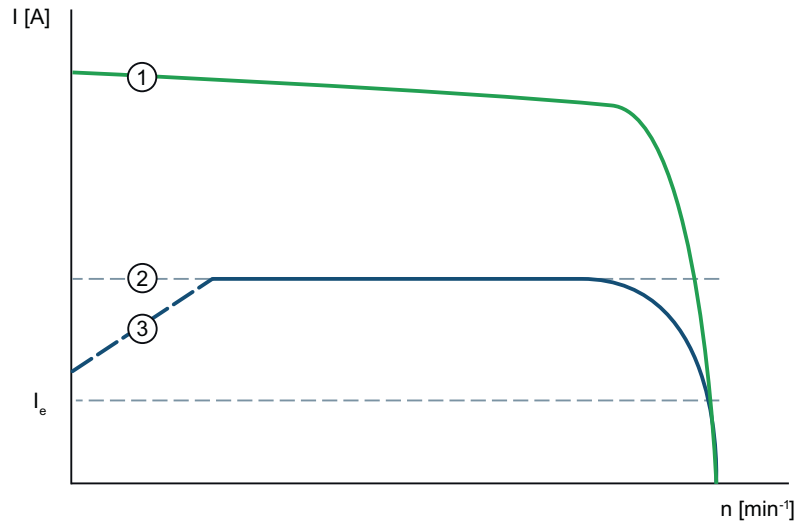

- ① Current characteristic with direct-on-line starting without 3RW55 or 3RW55 Failsafe soft starter
- ② Adjustable current limiting value
- ③ Voltage ramp
- I_e Rated operational current during rated operation

Parameters

In addition to the parameter below, the parameters of the starting mode "voltage ramp" (Page 136) also apply.

Parameters	Description
Current limiting value	<p>Set the current limiting value, as a factor of the rated motor current, to the maximum current required during startup. If the set current limiting value has been reached, the motor voltage is reduced or controlled by the 3RW55 or 3RW55 Failsafe soft starter to prevent the current from exceeding the set current limiting value.</p> <p>Select a minimum current limiting value that is high enough to ensure that the torque generated in the motor is sufficient to accelerate the motor to nominal speed. 3 to 4 times the value of the motor's rated operational current I_e can be assumed as typical here.</p> <p>(Identical to the parameters in chapters Automatic parameterization (Page 134) and Soft starting with torque control and current limiting (Page 144))</p> <ul style="list-style-type: none"> • Factory setting: 400% • Setting range: 125 ... 800% • In steps of: 1%

8.1.6 Soft starting with torque control and current limiting

Operating principle

Select the starting mode "Torque control + Current limiting" if, at the same time as protecting the system during startup of the motor or the connected load, you want to ensure that a specific current value is not exceeded. The motor is always started up with the torque control. If the current exceeds the parameterized current limit, the torque ramp is aborted and the current limitation function starts. The current limitation function remains active until the 3RW55 or 3RW55 Failsafe soft starter detects that the motor has ramped up and the motor is in a normal operating state.

Application

- Avoiding current surges
- Reducing energy costs
- During heavy starting

Setting via 3RW5 HMI High Feature

- Menu: "Parameters > Soft Starter > Parameter set 1 / 2 / 3 > Start settings > Starting mode > Torque control + Current limiting"
- Menu (Parameters): "Parameters > Soft Starter > Parameter set 1 / 2 / 3 > Start settings"
- Access protection to the 3RW5 HMI High Feature is not active or has been reset.

Current characteristic

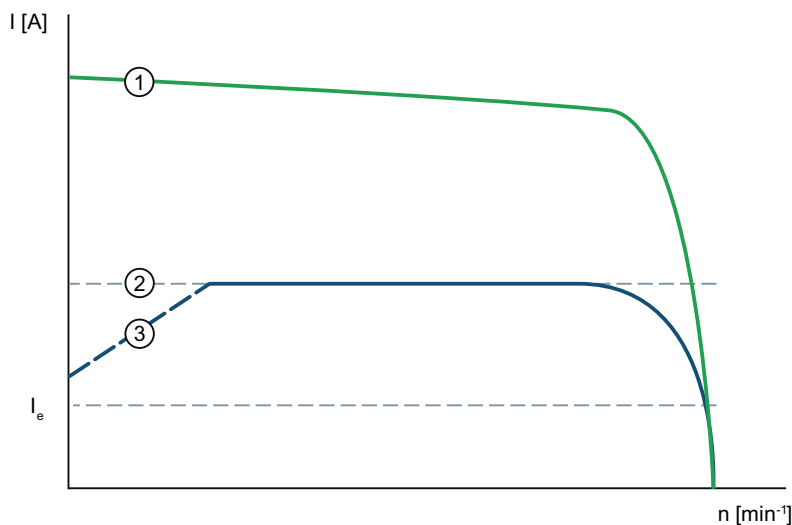

- ① Current characteristic with direct-on-line starting without 3RW55 or 3RW55 Failsafe soft starter
- ② Adjustable current limiting value
- ③ Torque control
- I_e Rated operational current during rated operation

Parameters

In addition to the parameter below, the parameters of the starting mode "torque control" (Page 139) also apply.

Parameters	Description
Current limiting value	<p>Set the current limiting value, as a factor of the rated motor current, to the maximum current required during startup. If the set current limiting value has been reached, the motor voltage is reduced or controlled by the 3RW55 or 3RW55 Failsafe soft starter to prevent the current from exceeding the set current limiting value.</p> <p>Select a minimum current limiting value that is high enough to ensure that the torque generated in the motor is sufficient to accelerate the motor to nominal speed. 3 to 4 times the value of the motor's rated operational current I_e can be assumed as typical here.</p> <p>(Identical to the parameters in chapters Soft starting with voltage ramp and current limiting (Page 142) and Automatic parameterization (Page 134))</p> <ul style="list-style-type: none"> • Factory setting: 400% • Setting range: 125 ... 800% • In steps of: 1%

8.1.7 Direct-on-line starting

Operating principle

The motor is switched on immediately without closed-loop control in the direction of rotation (right/CW = line phase direction). Starting takes place without being influenced by Current limiting by the 3RW55 or 3RW55 Failsafe soft starter, for example. Current limiting is only activated when 7.5 times the rated current of the soft starter is exceeded to avoid an overload.

If the starting mode "Direct" is set, a fast voltage ramp of approx. 100 ms will be effected on a start command. This limits the inrush current of the motor. After the 3RW55 or 3RW55 Failsafe soft starter has detected that the motor has ramped up, the bypasses are activated. This type of starting is equivalent to the starting behavior with a contactor.

Setting via 3RW5 HMI High Feature

- Menu: "Parameters > Soft Starter > Parameter set 1 / 2 / 3 > Start settings > Starting mode > Direct"
- Access protection to the 3RW5 HMI High Feature is not active or has been reset.

8.1.8 Motor heating

Operating principle

The starting mode "motor heating" heats up the motor. No startup takes place. The motor heating remains switched on for as long as the control command "Motor CW" or "Motor CCW" is present.

Assign your own parameter set for the motor heating to enable you to switch quickly and easily between the motor heating and the actual start-up.

Application

- Used for drives outdoors to minimize condensation inside the motor.

Validity

This starting mode is not available for the 3RW55 Failsafe soft starter.

Setting via 3RW5 HMI High Feature

- Menu: "Parameters > Soft Starter > Parameter set 1 / 2 / 3 > Start settings > Starting mode > Motor heating"
- Menu (Parameters): "Parameters > Soft Starter > Parameter set 1 / 2 / 3 > Start settings"
- Access protection to the 3RW5 HMI High Feature is not active or has been reset.

Parameters

NOTICE
Damage to property through motor heating in continuous operation
The starting mode "motor heating" is not a continuous operating mode. The motor must be equipped with a temperature sensor to ensure motor protection. The motor model with integrated electronic motor overload protection is not suitable for this kind of operation.

Parameters	Description
Motor heating power	Set the parameter so that the motor is not damaged. 100% motor heating power corresponds to a comparable motor current of about 30% of the rated motor current. <ul style="list-style-type: none"> • Factory setting: 20% • Setting range: 1 ... 100% • In steps of: 1%

8.1.9 Breakaway pulse for startup functions

Operating principle

It may be necessary to create a breakaway pulse at the beginning of the machine's starting process. Using the breakaway pulse, the high limiting friction of the load can be overcome and the machine can be set into motion. The breakaway pulse is used in conjunction with the starting modes "Voltage ramp", "Torque control", or "Current limiting" and overlays this during the set breakaway time.

Application

- Mills
- Crushers
- Drives with journal bearings

Setting via 3RW5 HMI High Feature

- Menu: "Parameters > Soft Starter > Parameter set 1 / 2 / 3 > Start settings"
- Access protection to the 3RW5 HMI High Feature is not active or has been reset.

Voltage characteristic

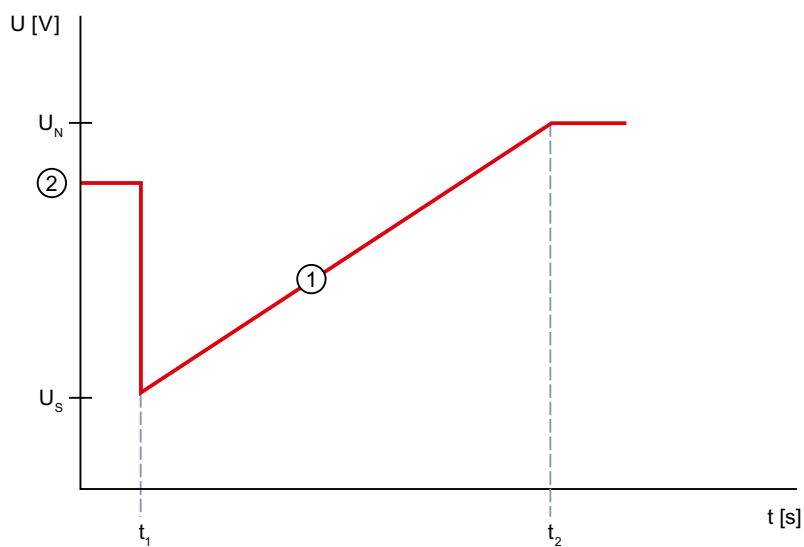

- ① Voltage ramp
- ② Parameterizable breakaway voltage
- t_1 Breakaway time
- $t_1 \dots t_2$ Ramp up time
- U_N Line voltage
- U_s Parameterizable starting voltage

Parameters

Parameters	Description
Breakaway time	<p>The breakaway time determines the period during which the breakaway voltage is to be present. Once the breakaway time has expired, the 3RW55 or 3RW55 Failsafe soft starter begins start-up with the selected starting mode, e.g. voltage ramp or torque control.</p> <p>Select a breakaway time that is at least long enough to ensure that, after the set time has elapsed, the motor does not stop again but continues to accelerate in the selected starting mode immediately. The setting "0 s" deactivates the function of the breakaway pulse.</p> <ul style="list-style-type: none"> • Factory setting: 0 s • Setting range: 0 ... 2 s • In steps of: 0.01 s
Breakaway voltage	<p>The breakaway voltage is used to set the breakaway torque to be generated. The breakaway torque can be up to 100% of the switch-on torque generated during direct-on-line starting.</p> <p>Select a breakaway voltage that is high enough to ensure that the motor starts rotating as soon as the start command is issued to the 3RW55 or 3RW55 Failsafe soft starter.</p> <ul style="list-style-type: none"> • Factory setting: 40% • Setting range: 40 ... 100% • In steps of: 5%

8.2 Run-down

8.2.1 Stopping modes

Operating principle

Just like starting, stopping can also be adapted to the application:

Setting options

- 3RW5 HMI High Feature
Menu: "Parameters > Soft Starter > Parameter set 1 / 2 / 3 > Stopping mode settings > Stopping mode"
Access protection to the 3RW5 HMI High Feature is not active or has been reset.
- With SIRIUS Soft Starter ES (TIA Portal) via the local interface on the 3RW5 HMI High Feature
Brief overview: Window "Project Navigation" with current project under created Soft Starter > "Parameters" > Window "Work area" > "Soft Starter > Parameter set 1 / 2 / 3 > Stopping mode settings"
- With a fieldbus via a 3RW5 communication module:
 - With SIRIUS Soft Starter ES (TIA Portal) Premium / Professional (only via a 3RW5 PROFINET or PROFIBUS communication module)
Brief overview: See SIRIUS Soft Starter ES (TIA Portal) via the local interface on the 3RW5 HMI High Feature
 - Configuration software of the control system (e.g. STEP 7 with corresponding HSP)
 - User program

You can find additional information on the parameters that can be set via the fieldbus in the manual of the respective 3RW5 communication module.

Stopping modes of the 3RW55 and 3RW55 Failsafe soft starters

- Coasting down (Page 150)
(Factory setting)
- Voltage ramp (Page 151)
- Torque control (Page 152)
- Pump stop (Page 154)
- DC braking with external braking contactors (Page 156)
This stopping mode is not available for the 3RW55 Failsafe soft starter.
- Dynamic DC braking without contactor (Page 159)
This stopping mode is not available for the 3RW55 Failsafe soft starter.
- Reversing DC braking with a reversing contactor assembly (Page 162)
This stopping mode is not available for the 3RW55 Failsafe soft starter.
- Alternative stopping (Page 165)

Speed curve

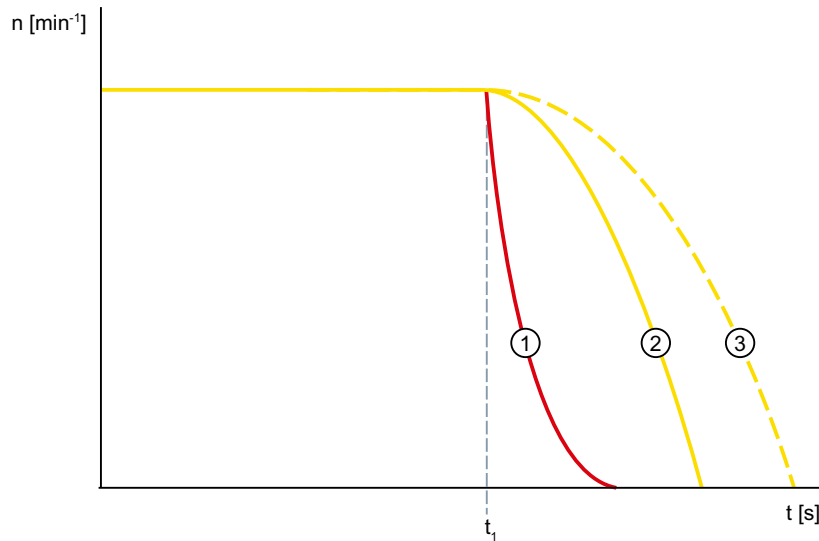

- ① n_{DC} braking
- ② $n_{Coasting\ down}$
- ③ $n_{Torque\ controlled\ stopping}$
- t_1 Stop command on the 3RW55 or 3RW55 Failsafe soft starter

8.2.2 Coasting down

Operating principle

Coasting down means the power supplied to the motor via the 3RW55 or 3RW55 Failsafe soft starter is interrupted when the ON command is removed from the 3RW55 or 3RW55 Failsafe soft starter. The motor will coast down freely without closed-loop control, driven only by the mass inertia (centrifugal mass) of the rotor and load. This is also referred to as natural stopping. A larger centrifugal mass means a longer stop time without load.

Coasting down is used for loads that make no special demand on the startup characteristic.

Application

- E.g. fan

Setting via 3RW5 HMI High Feature

- Menu: "Parameters > Soft Starter > Parameter set 1 / 2 / 3 > Stopping mode settings > Stopping mode > Coasting down"
- Access protection to the 3RW5 HMI High Feature is not active or has been reset.

8.2.3 Voltage ramp

Operating principle

With the stopping mode "Voltage ramp", the motor voltage is decreased along a linear, negative voltage ramp until the motor has stopped.

Application

- Drives that stop abruptly when switched off, causing the transported goods to be damaged, such as bottling plants.

Setting via 3RW5 HMI High Feature

- Menu: "Parameters > Soft Starter > Parameter set 1 / 2 / 3 > Stopping mode settings > Stopping mode > Voltage ramp"
- Menu (Parameters): "Parameters > Soft Starter > Parameter set 1 / 2 / 3 > Stopping mode settings"
- Access protection to the 3RW5 HMI High Feature is not active or has been reset.

Voltage characteristic

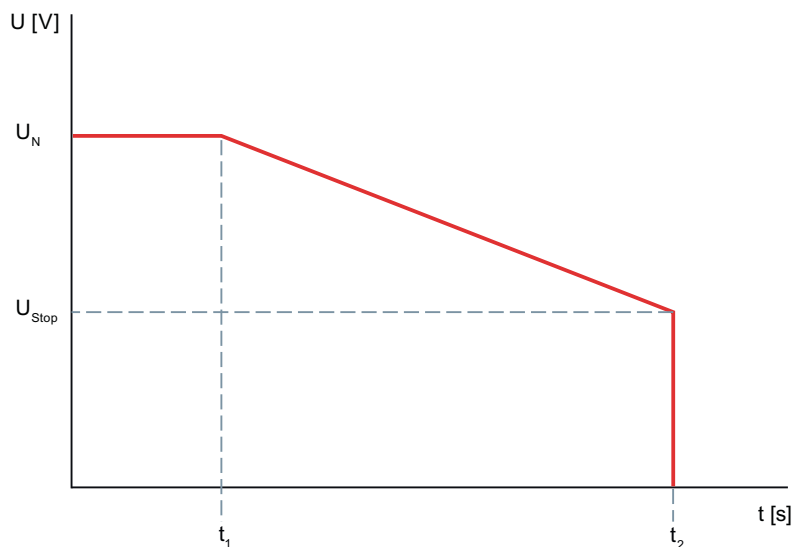

- $t_1 \dots t_2$ Stopping time
- U_N Line voltage
- U_{Stop} Stop voltage (50% of the line voltage)

Parameters

Parameters	Description
Stopping time	<p>The stopping time defines the time within which the motor voltage is reduced from line voltage to 0 V.</p> <p>It may take longer for the motor to actually coast down to a standstill.</p> <p>The setting "0 s" causes the motor to be shut down immediately without a down ramp.</p> <ul style="list-style-type: none"> • Factory setting: 10 s • Setting range: 0 ... 360 s • In steps of: 0.1 s

8.2.4 Torque control

Operating principle

Torque-controlled stopping extends the stopping of the load. The motor is powered down on a linear, negative torque ramp. This function is activated if there is a need to prevent the load from being stopped abruptly.

Application

- e.g. for conveyor belts, to prevent the conveyed materials from toppling.
- Applications with a low mass inertia or a high counter-torque.

Setting via 3RW5 HMI High Feature

- Menu: "Parameters > Soft Starter > Parameter set 1 / 2 / 3 > Stopping mode settings > Stopping mode > Torque control"
- Menu (Parameters): "Parameters > Soft Starter > Parameter set 1 / 2 / 3 > Stopping mode settings"
- Access protection to the 3RW5 HMI High Feature is not active or has been reset.

Torque curve

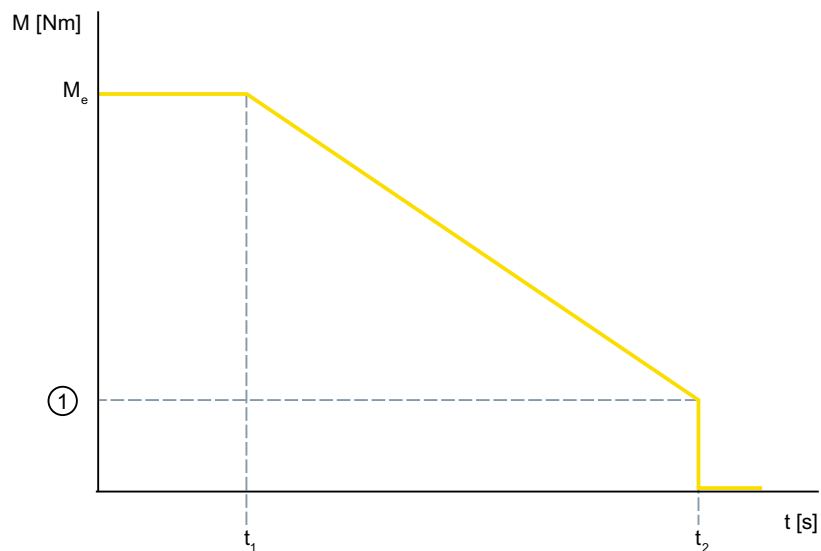

- ① Stopping torque
- $t_1 \dots t_2$ Stopping time
- M_e Rated torque

Parameters

Note

Motor data

For optimum torque control during the stopping procedure, enter the motor data of the motor connected to the 3RW55 or 3RW55 Failsafe soft starter in the selected parameter set using the "Motor parameters" menu item.

Menu: "Parameters > Soft Starter > Parameter set 1 / 2 / 3 > Motor parameters"

Parameters	Description
Stopping time	<p>The stopping time defines the time within which the motor voltage is reduced from line voltage to 0 V.</p> <p>It may take longer for the motor to actually coast down to a standstill.</p> <p>The setting "0 s" causes the motor to be shut down immediately without a down ramp.</p> <ul style="list-style-type: none"> • Factory setting: 10 s • Setting range: 0 ... 360 s • In steps of: 0.1 s
Stopping torque	<p>The motor torque is "controlled" until the stopping torque is reached and then switched off. The rated torque of the motor is used as the reference value.</p> <ul style="list-style-type: none"> • Factory setting: 10% • Setting range: 10 ... 100% • In steps of: 5%

8.2.5 Pump stop

Operating principle

With a torque-controlled pump stopping mode, stopping of the pump is prolonged. This stopping mode is set if there is a need to prevent the pump from being stopped abruptly.

Due to the very low moment of inertia that always applies in pumps, the pump operating mechanism (motor) can come to a standstill suddenly when shutting down, due to the counter-pressure of fluid in the piping system. This can result in pressure fluctuations in the pipe system which in turn cause loud noises (water hammer) and mechanical problems, e.g. to return valves. For this reason, the flow rate of the pump is reduced gradually during pump stopping mode. In the case of smaller pumps this effect can often be ignored.

Application

- Drives for which the abrupt stopping of the pump is to be prevented.

Setting via 3RW5 HMI High Feature

- Menu: "Parameters > Soft Starter > Parameter set 1 / 2 / 3 > Stopping mode settings > Stopping mode > Pump stopping mode"
- Menu (Parameters): "Parameters > Soft Starter > Parameter set 1 / 2 / 3 > Stopping mode settings"

Speed curve

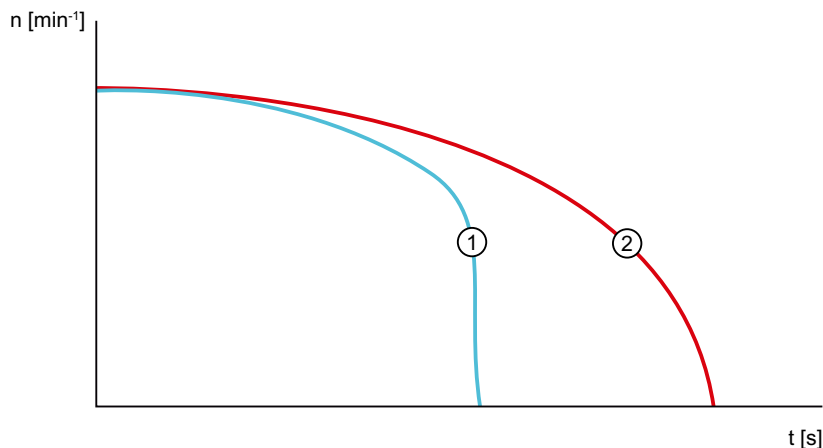

- ① Stopping mode "Voltage ramp"
- ② Stopping mode "Pump stopping mode"

Parameters

Note

Motor data

For optimum torque control during the stopping procedure, enter the motor data of the motor connected to the 3RW55 or 3RW55 Failsafe soft starter in the selected parameter set using the "Motor parameters" menu item.

Menu: "Parameters > Soft Starter > Parameter set 1 / 2 / 3 > Motor parameters"

Parameters	Description
Stopping time	<p>The stopping time defines the time within which the motor voltage is reduced from line voltage to 0 V.</p> <p>It may take longer for the motor to actually coast down to a standstill.</p> <p>The setting "0 s" causes the motor to be shut down immediately without a down ramp.</p> <ul style="list-style-type: none"> • Factory setting: 10 s • Setting range: 0 ... 360 s • In steps of: 0.1 s
Stopping torque	<p>The motor torque is "controlled" until the stopping torque is reached and then switched off. The rated torque of the motor is used as the reference value.</p> <ul style="list-style-type: none"> • Factory setting: 10% • Setting range: 10 ... 100% • In steps of: 5%

8.2.6 DC braking

8.2.6.1 DC braking with external braking contactors

Operating principle

In the case of DC braking, coasting down or the natural stopping of the load is shortened by electrical braking using a brake contactor. The 3RW55 soft starter impresses a (pulsating) direct current in phases L1 and L2 on the motor stator. This current generates a permanent magnetic field in the stator. Since the rotor is still rotating due to its mass inertia, currents are induced in the short-circuited rotor winding that generate a DC braking torque. If the braking process is not completed on expiry of the stopping time, the motor coasts down.

To guarantee a premature cancellation of the braking process, the "External motor standstill detection (Page 165)" or "Sensorless motor standstill detection (Page 164)" function can be used to detect motor standstill before the stopping time has elapsed. As motor protection, the use of the thermistor motor protection with temperature sensor (Page 171) is recommended.

If you use a 3RW55 soft starter with article number "3RW551-.....", "3RW5521-....." or "3RW5524-....." with a rated operational voltage U_e up to 400 V, you can only implement the stopping mode "DC braking" with an external braking contactor. Use 2 external braking contactors for 3RW55 soft starters from article number "3RW5525-....." or for a rated operational voltage U_e larger than 400 V.

Note the technical data of the braking contactors. You will find further information on braking contactors in Catalog IC 10 (<https://support.industry.siemens.com/cs/ww/en/view/109747945>).

Size	Article number of the 3RW55 soft starter	Number of required external braking contactors up to 400 V	Number of required external braking contactors higher than 400 V
Size 1	3RW551-.....	1 or 2	2
Size 2	3RW5521-.....		
	3RW5524-.....	2	
	3RW5525-.....		
	3RW5526-.....		
	3RW5527-.....		
Size 3	3RW553-.....		
Size 4	3RW554-.....		
Size 5	3RW555-.....		

Application

- Stopping in applications with large mass inertia (centrifugal masses): $J_{load} \leq 5 \times J_{motor}$
- Lathes (e.g. on a tool change)
- Circular saws
- Punches
- Conveyor belts

Additional information

You will find further information on the operating principle in chapters 3RW55 soft starter in standard (inline) circuit and stopping function DC braking with one braking contactor (Page 313) and 3RW55 soft starter in standard (inline) circuit and stopping function DC braking with 2 braking contactors (Page 315).

Validity

This stopping mode is not available for the 3RW55 Failsafe soft starter.

Requirements

- In this braking variant, one output action of the 3RW55 soft starter must be changed over to "DC brake contactor", through which an external braking contactor is controlled.
- 3RW55 soft starter in standard (inline) circuit
- Ex operation not active

Setting via 3RW5 HMI High Feature

- Menu: "Parameters > Soft Starter > Parameter set 1 / 2 / 3 > Stopping mode settings > Stopping mode > DC braking"
- Menu (Parameters): "Parameters > Soft Starter > Parameter set 1 / 2 / 3 > Stopping mode settings"
- Access protection to the 3RW5 HMI High Feature is not active or has been reset.

Torque characteristic without braking delay

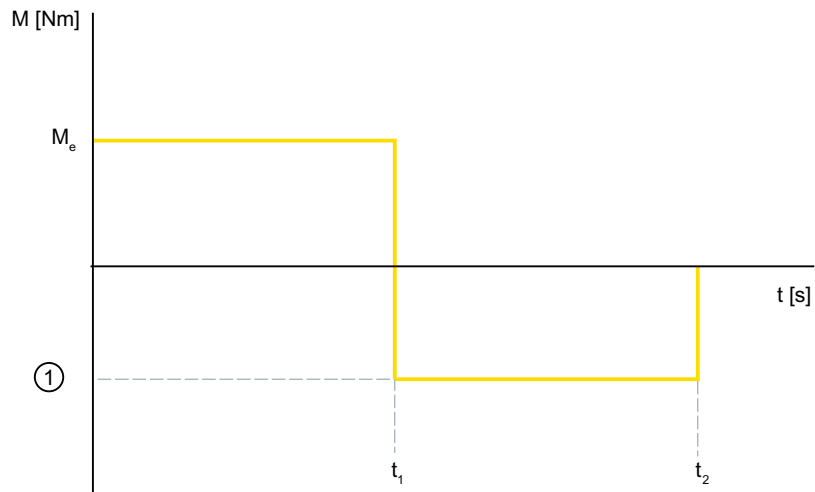

- ① DC braking torque
- t_1 Stop command on the 3RW55 soft starter
- $t_1 \dots t_2$ Stopping time
- M_e Rated torque

Torque characteristic with braking delay

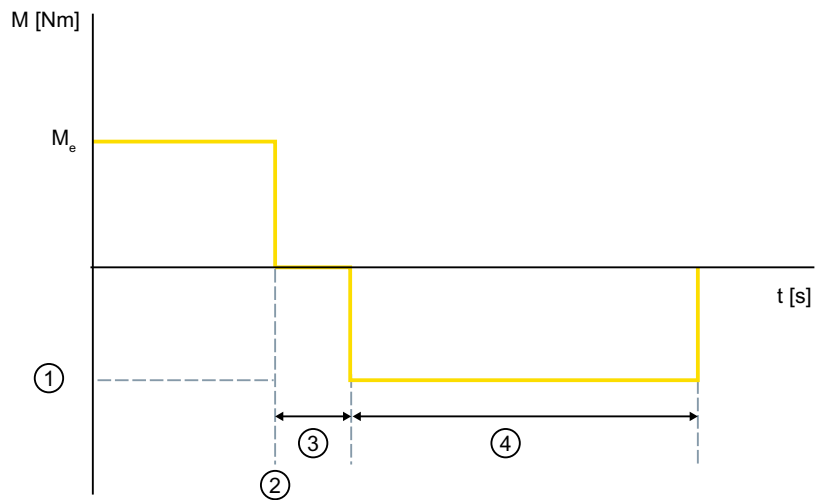

- ① DC braking torque
- ② Stop command on the 3RW55 soft starter
- ③ DC braking delay (coasting down)
- ④ Stopping time
- M_e Rated torque

Parameters

NOTICE
Damage to property due to DC braking
DC braking causes a higher current load and motor-specific noises and vibrations.
This can lead to premature failure of motor bearings. It may be necessary to overdimension the 3RW55 soft starter.

Parameters	Description
Stopping time	<p>On expiry of the stopping time, the DC braking procedure is automatically terminated. The setting "0 s" causes the motor to shut down immediately without DC braking.</p> <ul style="list-style-type: none"> • Factory setting: 10 s • Setting range: 0 ... 360 s • In steps of: 0.1 s
DC braking torque	<p>The motor's braking force can be set with the magnitude of the DC braking torque.</p> <ul style="list-style-type: none"> • Factory setting: 50% • Setting range: 20 ... 100% • In steps of: 5%
DC braking delay	<p>The DC brake delay starts when the motor OFF command ("Motor CW" and "Motor CCW" = 0) is detected. The motor coasts freely while the DC brake deceleration time elapses. After the DC braking delay has elapsed, DC braking is started.</p> <p>The motor brakes by free coasting, which means less energy is required for the following DC braking. This reduces the risk that the 3RW55 soft starter may overheat during DC braking.</p> <p>This parameter is used for "Stopping mode" and ignored for "Alternative stopping mode".</p> <ul style="list-style-type: none"> • Factory setting: 0 s • Setting range: 0 ... 360 s • In steps of: 0.1 s

8.2.6.2 Dynamic DC braking without contactor

Operating principle

Braking is performed in 2 phases. In the first phase the motor is braked by controlled DC braking pulses. In the second phase, the motor is brought to a standstill with a constant DC braking. Use DC braking if a uniformly long braking time is required.

To guarantee a premature cancellation of the braking process, the "External motor standstill detection (Page 165)" or "Sensorless motor standstill detection (Page 164)" function can be used to detect motor standstill before the stopping time has elapsed. As motor protection, the use of the thermistor motor protection with temperature sensor (Page 171) is recommended.

Application

- Stopping in applications with small mass inertia (centrifugal masses): $J_{load} \leq J_{motor}$
- If an electrical braking process without braking contactor is required.

Validity

This stopping mode is not available for the 3RW55 Failsafe soft starter.

Requirements

- 3RW55 soft starter in standard (inline) circuit
- Ex operation not active

Setting via 3RW5 HMI High Feature

- Menu: "Parameters > Soft Starter > Parameter set 1 / 2 / 3 > Stopping mode settings > Stopping mode > Dynamic DC braking"
- Menu (Parameters): "Parameters > Soft Starter > Parameter set 1 / 2 / 3 > Stopping mode settings"
- Access protection to the 3RW5 HMI High Feature is not active or has been reset.

Torque characteristic without braking delay

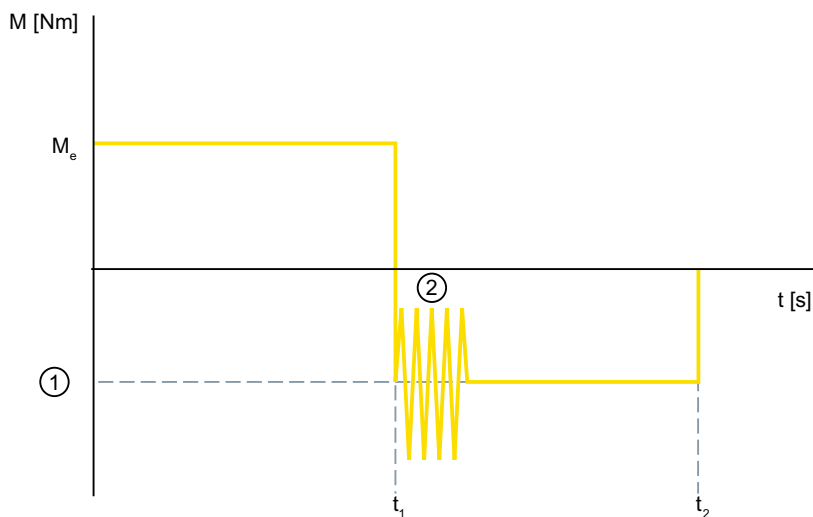

- ① DC braking torque
- ② Dynamic braking torque
- t_1 Stop command on the 3RW55 soft starter
- $t_1 \dots t_2$ Stopping time
- M_e Rated torque

Torque characteristic with braking delay

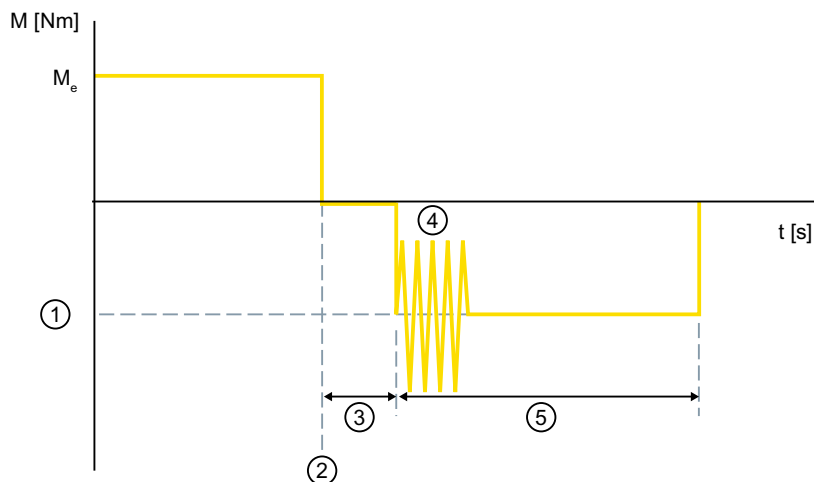

- ① DC braking torque
- ② Stop command on the 3RW55 soft starter
- ③ DC braking delay (coasting down)
- ④ Dynamic braking torque
- ⑤ Stopping time
- M_e Rated torque

Parameters

NOTICE
<p>Property damage due to DC braking pulses</p> <p>DC braking pulses cause a higher current load and motor-specific noises and vibrations. This can lead to premature failure of motor bearings. It may be necessary to overdimension the 3RW55 soft starter.</p>

Parameters	Description
Stopping time	<p>The stopping time specifies the period during which the DC braking torque is to be generated on the motor. The chosen braking time should be long enough to bring the load to a standstill. To achieve an adequate braking effect down to standstill, the centrifugal mass of the load should not exceed that of the motor. The length of the stopping time should be chosen such that the motor comes to a standstill.</p> <p>The actual stopping time may vary with this braking process.</p> <ul style="list-style-type: none"> • Factory setting: 10 s • Setting range: 0 ... 360 s • In steps of: 0.1 s
DC braking torque	<p>With the DC braking torque, the braking force of the motor in the second phase of braking can be set. The dynamic braking torque must be increased if the motor is to accelerate again during DC braking.</p> <ul style="list-style-type: none"> • Factory setting: 50% • Setting range: 20 ... 100% • In steps of: 5%
Dynamic braking torque	<p>The dynamic braking torque determines the braking effect in the first phase of braking to reduce the speed of the motor. After that, braking by DC braking is continued automatically.</p> <ul style="list-style-type: none"> • Factory setting: 50% • Setting range: 20 ... 100% • In steps of: 5%
DC braking delay	<p>The DC brake delay starts when the motor OFF command ("Motor CW" and "Motor CCW" = 0) is detected. The motor coasts freely while the DC brake deceleration time elapses. The dynamic DC braking is not started until the DC braking delay has elapsed.</p> <p>The motor brakes by free coasting, which means less energy is required for subsequent dynamic DC braking. This reduces the risk that the 3RW55 soft starter may overheat during dynamic DC braking.</p> <p>This parameter is used for "Stopping mode" and ignored for "Alternative stopping mode".</p> <ul style="list-style-type: none"> • Factory setting: 0 s • Setting range: 0 ... 360 s • In steps of: 0.1 s

8.2.6.3 Reversing DC braking with a reversing contactor assembly

Operating principle

In the stopping mode "Reversing DC braking", the motor is strongly braked with an external reversing contactor assembly. To avoid the motor turning in the opposite direction after braking, braking is divided into 2 braking phases. In the first braking phase, the 3RW55 soft starter brakes with reversing operation (external reversing contactor assembly), up to approx. 80% (factory setting) of the energy has been reduced. This energy is determined by the 3RW55 soft starter and corresponds to the starting energy. In the second braking phase, the 3RW55 soft starter brakes by DC braking (without the DC braking contactor) and reduces the remaining 20% of the energy. DC braking is brought to an end by stationary state detection. Stationary state detection requires use of the function "External motor standstill detection (Page 165)" or "Sensorless motor standstill detection (Page 164)".

The stopping mode "Reversing DC braking" with a reversing contactor assembly and the "reversing operation" function use the same line contactors. You can find more information on the method of operation in chapter Reversing duty (Page 324).

Application

- Applications that have to be braked quickly

Validity

This stopping mode is not available for the 3RW55 Failsafe soft starter.

Requirements

- 3RW55 soft starter from firmware version V2.0
- External reversing contactor assembly comprising 2 mechanically interlocked contactors
- 2 digital outputs
- 3RW55 soft starter in standard (inline) circuit
- Ex operation not active

Setting via 3RW5 HMI High Feature

- Menu: "Parameters > Soft Starter > Parameter set 1 / 2 / 3 > Stopping mode settings > Stopping mode > Reversing DC braking"
- Menu (Parameters): "Parameters > Soft Starter > Parameter set 1 / 2 / 3 > Stopping mode settings"
- Access protection to the 3RW5 HMI High Feature is not active or has been reset.

Parameters

Parameters	Description
Stopping time	<p>The length of the stopping time determines the duration of braking. The setting "0 s" causes termination without DC braking.</p> <ul style="list-style-type: none"> • Factory setting: 10 s • Setting range: 0 ... 360 s • In steps of: 0.1 s
DC braking torque	<p>With the DC braking torque, the brake force of the motor in the second phase of braking can be set. The dynamic braking torque must be increased if the motor is to accelerate again during DC braking.</p> <ul style="list-style-type: none"> • Factory setting: 50% • Setting range: 20 ... 100% • In steps of: 5%
Dynamic braking torque	<p>The dynamic braking torque determines the magnitude of the braking effect in the first braking phase to reduce the speed of the motor via reversing operation. In this way, the duration of the reversing operation in the first braking phase can be changed to avoid rotation in the opposite direction after braking. If you want to prolong the first braking phase, increase the dynamic braking torque, e.g. to 70%. If the motor rotates in the opposite direction after braking, reduce the dynamic braking torque, e.g. to 30%. The factory setting 50% corresponds to a reduction of approx. 80% of the energy in the first braking phase.</p> <ul style="list-style-type: none"> • Factory setting: 50% • Setting range: 20 ... 100% • In steps of: 5%

8.2.6.4 Sensorless motor standstill detection

Operating principle

The 3RW55 soft starter features integrated sensorless motor standstill detection. With this function, all stopping modes with braking can be brought to an end in good time as soon as the motor is at a standstill. The function can also be used independently of the stopping mode.

Application

- Timely detection of motor standstill for terminating braking

Validity

This function is not available for the 3RW55 Failsafe soft starter.

Requirements

- 3RW55 soft starter from firmware version V2.0
- Start-up completed
If standstill detection is required before start-up has been completed or in inching mode, use a standstill monitoring function with an encoder.

Setting via 3RW5 HMI High Feature

- Menu: "Parameters > Soft Starter > Parameter set 1 / 2 / 3 > Stopping mode settings"
- Access protection to the 3RW5 HMI High Feature is not active or has been reset.

Parameters

Parameters	Meaning
Sensorless motor standstill detection	<ul style="list-style-type: none"> • Activated (factory setting) • Deactivated

8.2.6.5 External motor standstill detection

Operating principle

The 3RW55 soft starter detects standstill of the motor shaft by external motor standstill detection. With this function, all stopping modes with braking can be brought to an end in good time as soon as the motor is at a standstill. The function can also be used independently of the stopping mode.

Application

- Timely detection of motor standstill for terminating braking

Validity

This function is not available for the 3RW55 Failsafe soft starter.

Requirements

- External motor standstill detection
- Parameterize the input connected to the external motor standstill detection with the input action "Motor standstill" (Page 196).

8.2.7 Alternative stopping

Operating principle

With the aid of a control command, you can switch from the parameterized stopping mode to a parameterizable Alternative stopping mode. Every stopping mode can be combined with every alternative stopping mode. The switchover to alternative stopping must take place before the start of the planned stopping. You cannot switch to alternative stopping while stopping.

Setting via 3RW5 HMI High Feature

- Menu: "Parameters > Soft Starter > Parameter set 1 / 2 / 3 > Stopping mode settings > Alternative stopping > Alternative stopping mode"
- Menu (Parameters): "Parameters > Soft Starter > Parameter set 1 / 2 / 3 > Stopping mode settings > Alternative stopping"
- Access protection to the 3RW5 HMI High Feature is not active or has been reset.

Parameters

Parameters	Description
Alternative stopping mode	<ul style="list-style-type: none"> • Coasting down (Page 150) (factory setting). • Voltage ramp (Page 151) • Torque control (Page 152) • Pump stopping mode (Page 154) • DC braking¹⁾ (Page 156) • Dynamic DC braking¹⁾ (Page 159) • Reversing DC braking¹⁾ (Page 162)
Alternative stopping time	<p>Depending on the alternative stopping mode set, observe the description of the parameter "Stopping time" in the relevant chapter:</p> <ul style="list-style-type: none"> • Voltage ramp (Page 151) • Torque control (Page 152) • Pump stopping mode (Page 154) • DC braking (Page 156) • Dynamic DC braking (Page 159) • Reversing DC braking (Page 162) <ul style="list-style-type: none"> • Factory setting: 10 s • Setting range: 0 ... 360 s • In steps of: 0.1 s
Alternative stopping torque	<p>Depending on the alternative stopping mode set, observe the description of the parameter "Stopping torque" in the relevant chapter:</p> <ul style="list-style-type: none"> • Torque control (Page 152) • Pump stopping mode (Page 154) <p>The motor torque is "controlled" until the alternative stopping torque is reached and then switched off. The rated torque of the motor is used as the reference value.</p> <ul style="list-style-type: none"> • Factory setting: 10% • Setting range: 10 ... 100% • In steps of: 5%

Parameters	Description
Alternative dynamic braking torque	<p>Depending on the alternative stopping mode set, observe the description of the parameter "Dynamic braking torque" in the relevant chapter:</p> <ul style="list-style-type: none"> • Dynamic DC braking (Page 159) • Reversing DC braking (Page 162) <ul style="list-style-type: none"> • Factory setting: 50% • Setting range: 20 ... 100% • In steps of: 5%
Alternative DC braking torque	<p>Irrespective of the set alternative stopping mode, not the description of the parameter "DC braking torque" in the relevant chapter:</p> <ul style="list-style-type: none"> • DC braking (Page 156) • Dynamic DC braking (Page 159) <ul style="list-style-type: none"> • Factory setting: 50% • Setting range: 20 ... 100% • In steps of: 5%
Alternative DC braking delay	<p>Depending on the alternative stopping mode set, observe the description of the parameter "DC braking delay" in the relevant chapter:</p> <ul style="list-style-type: none"> • DC braking (Page 156) • Dynamic DC braking (Page 159) <ul style="list-style-type: none"> • Factory setting: 0 s • Setting range: 0 ... 360 s • In steps of: 0.1 s

¹⁾ This stopping mode is not available for the 3RW55 Failsafe soft starter.

Switchover options

- 3RW5 HMI High Feature
Menu: "Control > Control motor > Enable / Disable alternative stopping mode"
Access protection to the 3RW5 HMI High Feature is not active or has been reset.
Refer to chapter Control via 3RW5 HMI High Feature (Page 234).
- With SIRIUS Soft Starter ES (TIA Portal) via the local interface on the 3RW5 HMI High Feature
Brief overview: Window "Task Card" > Tab "Online Tools" > "SIRIUS Control Panel"

- Input action (Page 196)
- With a fieldbus via a 3RW5 communication module:
 - With SIRIUS Soft Starter ES (TIA Portal) Premium / Professional (only via a 3RW5 PROFINET or PROFIBUS communication module)
Brief overview: See SIRIUS Soft Starter ES (TIA Portal) via the local interface on the 3RW5 HMI High Feature
 - Configuration software of the control system (e.g. STEP 7 with corresponding HSP)
 - User program

You can find additional information on the parameters that can be set via the fieldbus in the manual of the respective 3RW5 communication module.

8.3 Motor protection

The 3RW55 and 3RW55 Failsafe soft starters have 2 functions for protecting the motor:

- Electronic motor overload protection
- Thermistor motor protection with temperature sensor

Use a combination of both of these functions to implement full motor protection.

NOTICE

Deactivated motor protection can cause material damage.

If the motor is not monitored by a temperature sensor and the trip class is set to "CLASS OFF", no motor protection is provided.

Reset after cooling time

If the 3RW55 or 3RW55 Failsafe soft starter is switched off via a motor protection or intrinsic device protection tripping operation, the action cannot be acknowledged using the "Reset" function until the displayed cooling time has expired.

The behavior of the soft starter after an acknowledgment depends on the "Response to overload ..." parameter set for the particular function.

8.3.1 Electronic motor overload protection

Operating principle

The electronic motor overload protection calculates the approximate temperature of the motor from the measured motor currents and the device parameters "Rated operational current I_e " and "Trip class". This indicates whether the motor is overloaded or is functioning in the normal operating range. To do this, set the motor parameters (Page 97) of your motor.

The current motor temperature rise can be displayed via the measured value "Motor temperature rise" (Page 229)

Setting options

- 3RW5 HMI High Feature
Menu: "Parameters > Soft Starter > Parameter set 1 / 2 / 3 > Motor protection > Electronic motor overload protection"
Access protection to the 3RW5 HMI High Feature is not active or has been reset.
- With SIRIUS Soft Starter ES (TIA Portal) via the local interface on the 3RW5 HMI High Feature
Brief overview: Window "Project Navigation" with current project under created Soft Starter > "Parameters" > Window "Work area" > "Soft Starter > Parameter set 1 / 2 / 3 > Motor protection"
- With a fieldbus via a 3RW5 communication module:
 - With SIRIUS Soft Starter ES (TIA Portal) Premium / Professional (only via a 3RW5 PROFINET or PROFIBUS communication module)
Brief overview: See SIRIUS Soft Starter ES (TIA Portal) via the local interface on the 3RW5 HMI High Feature
 - Configuration software of the control system (e.g. STEP 7 with corresponding HSP)
 - User program

You can find additional information on the parameters that can be set via the fieldbus in the manual of the respective 3RW5 communication module.

Parameters

 WARNING
<p>Automatic restart following error acknowledgment/restart. Can cause death or serious injury.</p> <p>The 3RW55 and 3RW55 Failsafe soft starters immediately continue to operate with the values specified by the control following error acknowledgment / restart. Outputs are activated when the ON condition is met.</p> <p>Take appropriate measures to prevent unintentional restarting and to ensure a defined start of the system.</p>

Parameters		Description
Trip class		Deactivates the electronic motor overload protection. You will find further information below the table. <ul style="list-style-type: none"> • CLASS OFF
		The tripping times correspond to the trip class. You will find further information below the table. <ul style="list-style-type: none"> • CLASS 10A • CLASS 10E (factory setting) • CLASS 20E • CLASS 30E
Warning limits	Remaining time for tripping	The 3RW55 and 3RW55 Failsafe soft starters can generate a warning before imminent motor overload shutdown. The parameter "Remaining time for tripping" defines the time between the warning and imminent motor overload shutdown. The instant of the imminent motor overload shutdown is calculated on the assumption that the current operating conditions will continue. The setting "0 s" deactivates the function. <ul style="list-style-type: none"> • Factory setting: 0 s • Setting range: 0 ... 500 s • In steps of: 1 s The time until motor overload protection is tripped can be displayed via the measured value "Remaining time for motor overload protection" (Page 229).
	Temperature rise	You use this parameter to preset a motor temperature rise value in percent as a warning limit. The setting "0%" deactivates the function. <ul style="list-style-type: none"> • Factory setting: 0% • Setting range: 0 ... 99% • In steps of: 1%
Response to overload thermal motor model		Use this device parameter to specify how the 3RW55 and 3RW55 Failsafe soft starters are to respond to a motor overload: <ul style="list-style-type: none"> • Turn off without restart (factory setting) On the occurrence of the motor overload, an error is generated and the motor is tripped. When the parameterized recovery time (cooling time) has elapsed, the error and the trip can be acknowledged with the "Reset" function. • Turn off with restart On the occurrence of the motor overload, an error is generated and the motor is tripped. When the parameterized recovery time (cooling time) has elapsed, the error and the motor trip are automatically canceled.

Parameters	Description
Recovery time	<p>Minimum cooling down time for the motor after a motor overload trip. Reset signals present during the recovery time have no effect.</p> <ul style="list-style-type: none"> • Factory setting: 300 s • Setting range: 60 ... 1 800 s • In steps of: 30 s <p>The remaining recovery time following a motor overload shutdown can be displayed via the measured value "Remaining motor cooling time" (Page 229).</p>
Non-volatile tripping status	<p>If non-volatile tripping status is activated, the current tripping status of the electronic motor overload protection is stored in the 3RW55 or 3RW55 Failsafe soft starter. The current recovery time is only counted down after a motor overload shutdown if a supply voltage (control supply voltage) is applied to the 3RW55 or 3RW55 Failsafe soft starter. If the supply voltage (control supply voltage) is switched off in this period, counting down the recovery time is interrupted until the supply voltage (control supply voltage) is applied again.</p> <ul style="list-style-type: none"> • Yes (factory setting) • No

Trip class

The trip class (CLASS) specifies the maximum time within which a protective device must trip from a cold state at $7.2 \times$ the rated operational current I_e (motor protection to IEC 60947). The trip class defines the starting time at a particular current before the trip occurs.

You can set different tripping characteristics according to the startup class.

The higher the class, the longer the permitted starting time. You can find the graphic for the respective tripping characteristic at the following link (<https://support.industry.siemens.com/cs/ww/en/ps/25099/char>).

8.3.2 Temperature sensor

Operating principle

You can connect the temperature sensor of the motor to the 3RW55 and 3RW55 Failsafe soft starters and evaluate it. If a specific motor-dependent temperature is exceeded, the 3RW55 or 3RW55 Failsafe soft starter recognizes this and reacts accordingly. You can set the reaction.

2 different types of measuring sensor can be connected to the 3RW55 or 3RW55 Failsafe soft starter:

- PTC thermistors type A
This sensor type is a temperature-dependent resistor.
- Thermoclick
This sensor type is a temperature-dependent switch.

Note

ATEX/IECEX/UKEX-certified motor protection

For ATEX/IECEX/UKEX-certified motor protection, use of the PTC type A sensor only is approved.

The sensor cables of PTC thermistors type A can be monitored for wire break and short-circuit.

You will find more information on the connection of the temperature sensor in chapter Connecting the temperature sensor (Page 305).

Setting options

- 3RW5 HMI High Feature
Menu: "Parameters > Soft Starter > Parameter set 1 / 2 / 3 > Motor protection > Temperature sensor"
Access protection to the 3RW5 HMI High Feature is not active or has been reset.
- With SIRIUS Soft Starter ES (TIA Portal) via the local interface on the 3RW5 HMI High Feature
Brief overview: Window "Project Navigation" with current project under created Soft Starter > "Parameters" > Window "Work area" > "Soft Starter > Parameter set 1 / 2 / 3 > Motor protection"
- With a fieldbus via a 3RW5 communication module:
 - With SIRIUS Soft Starter ES (TIA Portal) Premium / Professional (only via a 3RW5 PROFINET or PROFIBUS communication module)
Brief overview: See SIRIUS Soft Starter ES (TIA Portal) via the local interface on the 3RW5 HMI High Feature
 - Configuration software of the control system (e.g. STEP 7 with corresponding HSP)
 - User program

You can find additional information on the parameters that can be set via the fieldbus in the manual of the respective 3RW5 communication module.

Parameters

 WARNING
<p>Automatic restart following fault acknowledgment/restart. Can cause death or serious injury.</p> <p>The 3RW55 and 3RW55 Failsafe soft starters immediately continue to operate with the values specified by the control following error acknowledgment / restart. Outputs are activated when the ON condition is met.</p> <p>Take appropriate measures to prevent unintentional restarting and to ensure a defined start of the system.</p>

Parameters		Description
Temperature sensor ¹⁾	Sensor type	<ul style="list-style-type: none"> • Deactivated (factory setting) The motor protection function is deactivated. • Thermoclick This sensor type is a temperature-dependent switch. • PTC type A This sensor type is a temperature-dependent resistor.
	Response to overload temperature sensor	<p>If the temperature sensor detects an overload on the motor, this is signaled to the 3RW55 or 3RW55 Failsafe soft starter. You can set the response to this:</p> <ul style="list-style-type: none"> • Turn off without restart (factory setting) On an overtemperature, an error is generated and the motor is shut down. After the motor has cooled down, the error and the trip can be acknowledged with the "Reset" function. • Turn off with restart On an overtemperature, an error is generated and the motor is shut down. After the motor has cooled down, the error and the motor trip are automatically canceled. • Warn On an overtemperature, only a warning is output. After the motor has cooled down, the warning is canceled automatically.

¹⁾ Generally valid parameter that can only be set in Parameter set 1.

8.4 Intrinsic device protection

Operating principle

The 3RW55 and 3RW55 Failsafe soft starters have integrated intrinsic device protection (power semiconductors and bypasses) that prevents inadmissible thermal overloading of the switching elements.

In order to protect the bypasses and power semiconductors, the startup and maximum operational currents of the motor are limited and the temperature monitored if current measurement is available. The intrinsic device protection does not protect from short-circuit stress.

The current switching element heating can be displayed via the measured value "Switching element heating" (Page 229)

Acknowledgment after cooling time has elapsed.

If the 3RW55 or 3RW55 Failsafe soft starter is switched off via a motor protection or intrinsic device protection tripping operation, the action cannot be acknowledged using the "Reset" (Page 175) function until the cooling time of the switching element has expired. The remaining cooling time can be displayed via the measured value "Remaining switching element cooling time" (Page 229).

The behavior of the soft starter after an acknowledgment depends on the "Response to overload ..." parameter set for the particular function. You can set the behavior of the "intrinsic device protection" function via the menu "Additional parameters", see Chapter "Functions under "Additional parameters" (Page 216)".

8.5 Creep speed

Operating principle

The "Creep speed" function enables the motor to be controlled at low speed in both directions during operation. The result of this function, however, is that only a reduced torque can be generated in the motor. Due to possible temperature rise of the motor, this function is not suitable for continuous operation. As motor protection, the use of the thermistor motor protection with temperature sensor (Page 171) is recommended. Furthermore, the creep speed causes mechanical vibrations, which can reduce the lifetime of the bearings. In addition to the set parameters, motor-specific characteristics and the connected load influence the speed resulting from the "Creep speed" function and creep speed generated in the motor. The "creep speed" function is active for as long as the "Creep speed" control command is set.

You will find more information in chapter 3RW55 soft starter in standard (inline) circuit with soft starting, soft stopping and the additional function "Creep speed" (Page 317).

Application

- In applications with a low counter-torque, e.g. positioning of machine tools.

Validity

This function is not available for the 3RW55 Failsafe soft starter.

Setting options

- 3RW5 HMI High Feature
Menu: "Parameters > Soft Starter > Parameter set 1 / 2 / 3 > Creep speed"
Access protection to the 3RW5 HMI High Feature is not active or has been reset.
- With SIRIUS Soft Starter ES (TIA Portal) via the local interface on the 3RW5 HMI High Feature
Brief overview: Window "Project Navigation" with current project under created Soft Starter > "Parameters" > Window "Work area" > "Soft Starter > Parameter set 1 / 2 / 3 > Creep speed"
- With a fieldbus via a 3RW5 communication module:
 - With SIRIUS Soft Starter ES (TIA Portal) Premium / Professional (only via a 3RW5 PROFINET or PROFIBUS communication module)
Brief overview: See SIRIUS Soft Starter ES (TIA Portal) via the local interface on the 3RW5 HMI High Feature
 - Configuration software of the control system (e.g. STEP 7 with corresponding HSP)
 - User program

You can find additional information on the parameters that can be set via the fieldbus in the manual of the respective 3RW5 communication module.

Parameters

Parameters	Description
Creep speed factor right	<p>The speed is reduced by the creep speed factor, in other words the rotational speed in creep speed mode is the quotient derived from rated operating speed and creep speed factor.</p> <p>The "creep speed" function operates ideally at a creep speed factor of 7 ... 9.</p> <ul style="list-style-type: none"> • Factory setting: 7 • Setting range: 3 ... 21 • In steps of: 1
Creep speed factor left	
Creep speed torque right	<p>The torque generated in the motor is influenced with the creep speed torque. The maximum torque that can be generated depends on the selected creep speed. 100% creep speed torque corresponds to approximately 30% of the rated motor torque.</p> <ul style="list-style-type: none"> • Factory setting: 50% • Setting range: 20 ... 100% • In steps of: 5%
Creep speed torque left	

Switchover options

- 3RW5 HMI High Feature
Menu: "Control > Control motor > Enable / Disable creep speed"
Access protection to the 3RW5 HMI High Feature is not active or has been reset.
Refer to chapter Control via 3RW5 HMI High Feature (Page 234).
- With SIRIUS Soft Starter ES (TIA Portal) via the local interface on the 3RW5 HMI High Feature
Brief overview: Window "Task Card" > Tab "Online Tools" > "SIRIUS Control Panel"
- Input action (Page 196)
- With a fieldbus via a 3RW5 communication module:
 - With SIRIUS Soft Starter ES (TIA Portal) Premium / Professional (only via a 3RW5 PROFINET or PROFIBUS communication module)
Brief overview: See SIRIUS Soft Starter ES (TIA Portal) via the local interface on the 3RW5 HMI High Feature
 - Configuration software of the control system (e.g. STEP 7 with corresponding HSP)
 - User program

You can find additional information on the parameters that can be set via the fieldbus in the manual of the respective 3RW5 communication module.

8.6 Reset

Operating principle

You can acknowledge current errors with the "Reset" function once they have been remedied.

Execution options

- 3RW5 HMI High Feature
 - Menu: "Control > Reset"
 - Configured function selection key F1-F9 (Page 119)
- With SIRIUS Soft Starter ES (TIA Portal) via the local interface on the 3RW5 HMI High Feature
Brief overview: Window "Task Card" > Tab "Online Tools" > "SIRIUS Control Panel"
- With a fieldbus via a 3RW5 communication module (only via a 3RW5 PROFINET or PROFIBUS communication module):
 - With SIRIUS Soft Starter ES (TIA Portal) Premium / Professional
Brief overview: See SIRIUS Soft Starter ES (TIA Portal) via the local interface on the 3RW5 HMI High Feature
 - Configuration software of the control system (e.g. STEP 7 with corresponding HSP)
 - With the "Reset" command in data record 93

8.7 Quick-stop

Operating principle

You can assign the "Quick-stop" input action to the digital inputs (Page 196). With a Quick-stop the motor is shut off in normal operation with the currently set stopping function. Quick-stop is executed regardless of where master control lies and a group error is not signaled.

You can use the "Disable Quick-stop" (Page 234) command to deactivate execution of the "Quick-stop" input action.

8.8 Condition Monitoring

8.8.1 Condition Monitoring for plant monitoring

Operating principle

Condition monitoring monitors your plant and is able to detect incipient wear at an early stage. This enables you to avoid unplanned plant downtimes and loss of production. To do this, you can specify the response to limit violations of the following functions:

- Current monitoring (Page 177)
- Active power monitoring (Page 179)
- Switching frequency monitoring (Page 180)
- Starting time monitoring (Page 183)
- Pump cleaning function (Page 184)

Setting options

- 3RW5 HMI High Feature
Menu: "Parameters > Soft Starter > Parameter set 1 / 2 / 3 > Condition Monitoring"
Access protection to the 3RW5 HMI High Feature is not active or has been reset.
- With SIRIUS Soft Starter ES (TIA Portal) via the local interface on the 3RW5 HMI High Feature
Brief overview: Window "Project Navigation" with current project under created Soft Starter > "Parameters" > Window "Work area" > "Soft Starter > Parameter set 1 / 2 / 3 > Condition Monitoring"
- With a fieldbus via a 3RW5 communication module:
 - With SIRIUS Soft Starter ES (TIA Portal) Premium / Professional (only via a 3RW5 PROFINET or PROFIBUS communication module)
Brief overview: See SIRIUS Soft Starter ES (TIA Portal) via the local interface on the 3RW5 HMI High Feature
 - Configuration software of the control system (e.g. STEP 7 with corresponding HSP)
 - User program

You can find additional information on the parameters that can be set via the fieldbus in the manual of the respective 3RW5 communication module.

8.8.2 Current monitoring

Operating principle

The current flow is influenced by the loading status of the motor.

- If the motor current is increased, this indicates bearing damage, for example.
- If a very low motor current is flowing, this can indicate a broken conveyor belt or a motor in no-load operation.
- If a very high motor current is flowing, this can indicate a blocked system and an overloaded motor.

The current monitoring is deactivated automatically during starting and stopping. The rated operational current I_e acts as a reference value for the current limit monitoring function.

Setting via 3RW5 HMI High Feature

- Menu: "Parameters > Soft Starter > Parameter set 1 / 2 / 3 > Condition Monitoring > Current monitoring"
- Access protection to the 3RW5 HMI High Feature is not active or has been reset.

Parameters

Parameters	Description
Upper limit	
Upper limit - error	<p>If the current exceeds this limit, an error is generated and the 3RW55 and 3RW55 Failsafe soft starters behave as set in the parameter "Response to error". The setting "0%" deactivates the monitoring of the limit value.</p> <ul style="list-style-type: none"> • Factory setting: 0% • Setting range: 50 ... 400 % • In steps of: 1%
Upper limit - maintenance demanded	<p>If the current exceeds this limit, a warning is generated. The setting "0%" deactivates the monitoring of the limit value.</p> <ul style="list-style-type: none"> • Factory setting: 0% • Setting range: 50 ... 400 % • In steps of: 1%
Response to error ¹⁾	<p>Do not turn off (factory setting) On exceeding the "Upper limit - error" the motor is not turned off.</p>
	<p>Turn off On exceeding the "Upper limit - error" the motor is turned off.</p>
Lower limit	
Lower limit - error	<p>If the current fails to reach this lower limit, an error is generated and the 3RW55 and 3RW55 Failsafe soft starters behave as set in the parameter "Response to error". The setting "0%" deactivates the monitoring of the limit value.</p> <ul style="list-style-type: none"> • Factory setting: 0% • Setting range: 19 ... 100% • In steps of: 1%
Lower limit - maintenance demanded	<p>If the current fails to reach this lower limit, a warning is generated. The setting "0%" deactivates the monitoring of the limit value.</p> <ul style="list-style-type: none"> • Factory setting: 0% • Setting range: 19 ... 100% • In steps of: 1%
Response to error ¹⁾	<p>Do not turn off (factory setting) If the "Lower limit - error" is undershot, the motor is not turned off.</p>
	<p>Turn off If the "Lower limit - error" is undershot, the motor is turned off.</p>

¹⁾ Generally valid parameter that can only be set in Parameter set 1.

8.8.3 Active power monitoring

Operating principle

The active power is influenced by the loading status of the motor. Depending on the limit that is exceeded, a warning or an error is signaled. The active power monitoring is deactivated during starting and stopping. The current active power heating can be displayed via the measured value "Active power" (Page 229)

Application

- Load monitoring for over-dimensioned motors
- Detection of pumps running empty and avoidance of damage to pump gears
- Avoidance of load peaks
- Derivation of production quality data from energy data

Setting via 3RW5 HMI High Feature

- Menu: "Parameters > Soft Starter > Parameter set 1 / 2 / 3 > Condition Monitoring > Active power monitoring"
- Access protection to the 3RW5 HMI High Feature is not active or has been reset.

Parameters

Parameters	Description
Reference value	<p>Set the rated motor power for the reference value. The rated motor power can be obtained from the motor data. The following limits for active power monitoring refer to this reference value (rated motor power). The setting "0 W" deactivates the active power monitoring.</p> <ul style="list-style-type: none"> • Factory setting: 0 W • Setting range: 0 W ... 2 000 kW • In steps of: 1 W
Upper limit	
Upper limit - error	<p>If the active power exceeds this limit, an error is generated and the 3RW55 and 3RW55 Failsafe soft starters behave as set in the parameter "Response to error". The setting "0%" deactivates the monitoring of the limit value.</p> <ul style="list-style-type: none"> • Factory setting: 0% • Setting range: 0 ... 400% • In steps of: 1%
Upper limit - maintenance demanded	<p>If the active power exceeds this limit, a warning is generated. The setting "0%" deactivates the monitoring of the limit value.</p> <ul style="list-style-type: none"> • Factory setting: 0% • Setting range: 0 ... 400% • In steps of: 1%

8.8 Condition Monitoring

Parameters	Description
Response to error ¹⁾	Do not turn off (factory setting) On exceeding the "Upper limit - error" the motor is not turned off.
	Turn off On exceeding the "Upper limit - error" the motor is turned off.
Lower limit	
Lower limit - error	If the active power fails to reach this lower limit, an error is generated and the 3RW55 and 3RW55 Failsafe soft starters behave as set in the parameter "Response to error". The setting "0%" deactivates the monitoring of the limit value. <ul style="list-style-type: none"> • Factory setting: 0% • Setting range: 0 ... 100% • In steps of: 1%
Lower limit - maintenance demanded	If the active power fails to reach this lower limit, a warning is generated. The setting "0%" deactivates the monitoring of the limit value. <ul style="list-style-type: none"> • Factory setting: 0% • Setting range: 0 ... 100% • In steps of: 1%
Response to error ¹⁾	Do not turn off (factory setting) If the "Lower limit - error" is undershot, the motor is not turned off.
	Turn off If the "Lower limit - error" is undershot, the motor is turned off.

¹⁾ Generally valid parameter that can only be set in Parameter set 1.

8.8.4 Switching frequency monitoring

Operating principle

If motors are started frequently, this can cause the motor to overheat. The 3RW55 and 3RW55 Failsafe soft starters monitor the switching frequency in order to adhere to the waiting and cooling times.

Application

- Prevention of process-related critical application states that occur as a result of too frequent starting in conjunction with insufficient cooling time (Mode 1) or as a result of not observing cooling times between 2 operating phases (Mode 2).
- For example, refrigeration compressors that have to remain switched off for a specific time after reaching a maximum number of starts.

Setting via 3RW5 HMI High Feature

- Menu: "Parameters > Soft Starter > Parameter set 1 / 2 / 3 > Condition Monitoring > Switching frequency monitoring"
- Access protection to the 3RW5 HMI High Feature is not active or has been reset.

Switching frequency monitoring - Mode 1 (ON - ON)

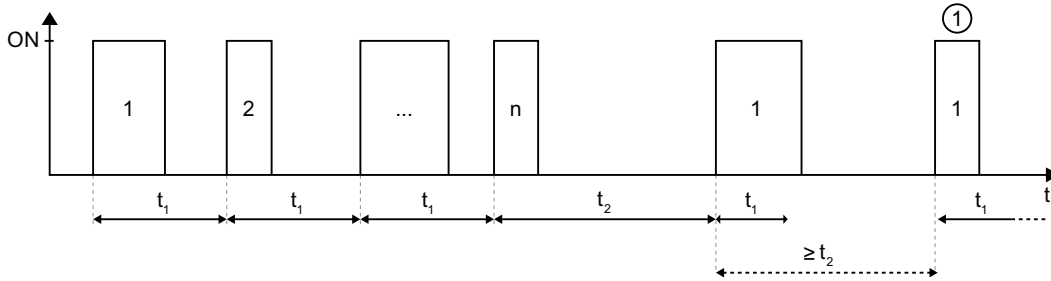

- ① Counter for the number of starts begins at "1".
- n Maximum number of starts
- t₁ Switching frequency monitoring time t₁
- t₂ Switching frequency monitoring time t₂

Switching frequency monitoring - Mode 2 (OFF - ON)

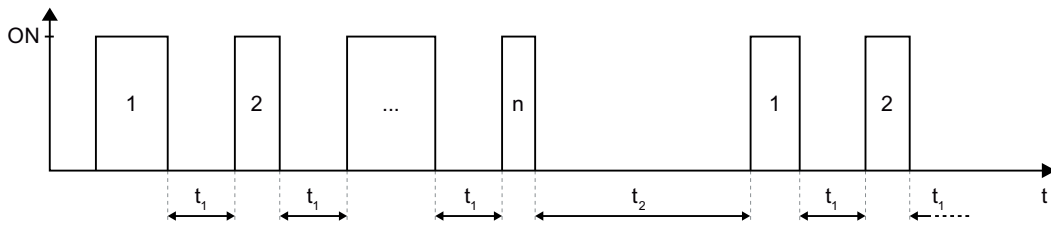

- n Maximum number of starts
- t₁ Switching frequency monitoring time t₁
- t₂ Switching frequency monitoring time t₂

Parameters

Parameters	Description
Switching frequency monitoring mode	Deactivated (factory setting) The switching frequency monitoring is deactivated.
	Mode 1 (ON - ON) The switching frequency monitoring always relates to the start time of the preceding Motor ON command and the start time of the new Motor ON command. Comparison of the switching frequency monitoring time t ₁ and t ₂ starts as soon as an effective switch-on command is present.
	Mode 2 (OFF - ON) The switching frequency monitoring always relates to the end time of the preceding Motor ON command (Motor OFF) and the starting time of the new Motor ON command. Comparison of the switching frequency monitoring time t ₁ and t ₂ starts as soon as a switch-on command is no longer present.

8.8 Condition Monitoring

Parameters	Description
Switching frequency monitoring time t_1	<p>The time t_1 selected must be shorter than the time t_2 or it must be deactivated. If the switching frequency monitoring time t_1 according to the set mode is not observed, the 3RW55 and 3RW55 Failsafe soft starters behave as set in the parameter "Response to ON command during active monit. time".</p> <p>The setting "0 s" deactivates the Switching frequency monitoring time t_1.</p> <ul style="list-style-type: none"> • Factory setting: 0 s • Setting range: 0 ... 65 535 s • In steps of: 1 s
Switching frequency monitoring time t_2	<p>The time t_2 selected must be longer than the time t_1 or it must be deactivated. The parameter is relevant in relation to the parameter "Maximum number of starts".</p> <p>The setting "0 s" deactivates the Switching frequency monitoring time t_2.</p> <ul style="list-style-type: none"> • Factory setting: 0 s • Setting range: 0 ... 65 535 s • In steps of: 1 s
Maximum number of starts	<p>This parameter is only relevant in combination with the switching frequency monitoring time t_2. If the parameter "Switching frequency monitoring time t_2" is deactivated (0 s, factory setting), the parameter "Maximum number of starts" is also deactivated.</p> <p>The parameter "Maximum number of starts" determines the number of starts for which the switching frequency monitoring time t_2 according to the set mode does not have to be observed. An internal counter counts the starts for which the switching frequency monitoring time t_2 is not observed. At the latest upon reaching the maximum number of starts, the switching frequency monitoring time t_2 must be observed once. If the switching frequency monitoring time t_2 is observed before reaching the maximum number of starts, the counter begins again at "1".</p> <p>If, upon reaching the maximum number of starts, the switching frequency monitoring time t_2 according to the set mode is not observed, the 3RW55 and 3RW55 Failsafe soft starters behave as set in the parameter "Response to ON command during active monit. time".</p> <ul style="list-style-type: none"> • Factory setting: 2 • Setting range: 2 ... 255 • In steps of: 1

Parameters	Description
Response to ON command during active monit. time	<p>Turn off with restart</p> <p>If an ON command for the motor is issued before the switching frequency monitoring time t_1 or t_2 elapses, an error is generated and the motor is not switched on (internal trip command). The trip is not automatically acknowledged until t_1 or t_2 elapses, and the motor is switched on when an ON command is still present.</p> <p>The trip can be bypassed using the "Emergency start" (Page 191) function. If the emergency start function is activated in advance, the motor is switched on despite the error message.</p>
	<p>Turn off without restart</p> <p>If an ON command for the motor is issued before the switching frequency monitoring time t_1 or t_2 elapses, an error is generated and the motor is not switched on (internal trip command). The trip must be acknowledged with the "Reset" (Page 175) function.</p> <p>The trip can be bypassed using the "Emergency start" (Page 191) function. If the emergency start function is activated in advance, the motor is switched on despite the error message.</p>
	<p>Warning without lock-out</p> <p>If an ON command is issued for the motor before switching frequency monitoring time t_1 or t_2 elapses, a warning is generated and the motor is switched on normally and not locked.</p>
	<p>Warning with lock-out (factory setting)</p> <p>If an ON command is issued for the motor before switching frequency monitoring time t_1 or t_2 elapses, a warning is generated and the motor is not switched on and locked. If an ON command is still present, the motor is not switched on until t_1 or t_2 elapses.</p>

Measured value "Remaining switching frequency monit. time"

If the motor cannot be switched on until t_1 or t_2 elapses, the remaining time can be displayed via the measured value "Remaining switching frequency monit. time" (Page 229).

8.8.5 Starting time monitoring

Operating principle

An over/undershoot of the preset starting time can indicate an overload or underload of the system.

Setting via 3RW5 HMI High Feature

- Menu: "Parameters > Soft Starter > Parameter set 1 / 2 / 3 > Condition Monitoring > Starting time monitoring"
- Access protection to the 3RW5 HMI High Feature is not active or has been reset.

Parameters

Parameters	Description
Preset starting time (identical to the parameter of the Automatic parameterization (Page 134))	The following limits for starting time monitoring refer to this parameter. The setting "0 s" deactivates starting time monitoring. <ul style="list-style-type: none"> • Factory setting: 10 s • Setting range: 0 ... 360 s • In steps of: 0.1 s
Upper limit - maintenance demanded	If the ACTUAL starting time exceeds this limit, a warning is generated. The motor is not shut off. If this limit has not been exceeded at the end of the motor starting phase, then any pending warning is reset. The setting "0%" deactivates the monitoring of the limit value. <ul style="list-style-type: none"> • Factory setting: 0% • Setting range: 0 ... 400% • In steps of: 1%
Lower limit - maintenance demanded	If the ACTUAL starting time fails to reach this lower limit, a warning is generated. The motor is not shut off. If this lower limit is reached at the end of the motor starting phase, then any pending warning is reset. The setting "0%" deactivates the monitoring of the limit value. <ul style="list-style-type: none"> • Factory setting: 0% • Setting range: 0 ... 100% • In steps of: 1%

8.8.6 Pump cleaning function

Operating principle

The pump cleaning function provides support with maintaining pump systems by preventing an imminent blockage or, up to a point, also clearing an existing blockage. Pump cleaning is only possible if the pump is switched on, if one or both control commands "Motor CW" or "Motor CCW" is present, and if there is no internal trip command (e.g. disconnection due to motor overload trip) or the internal trip command is ignored by the "Emergency start" (Page 191) function. Cancellation of the control command or occurrence of an internal trip command while emergency start is inactive causes the pump cleaning process to be aborted.

You will find further information on the pump cleaning function in the Internet under the FAQs (<https://support.industry.siemens.com/cs/ww/en/view/109761112>).

Application

- Clearance of blockages and dirt from water pipes, filters, and pump blades

Activation options

If the "Pump cleaning - mode" parameter is set to "Manual", you can start and stop the pump cleaning function as follows:

- 3RW5 HMI High Feature
Menu: "Control > Control motor > Pump cleaning start / stop"
Access protection to the 3RW5 HMI High Feature is not active or has been reset.
Refer to chapter Control via 3RW5 HMI High Feature (Page 234).
- With SIRIUS Soft Starter ES (TIA Portal) via the local interface on the 3RW5 HMI High Feature
Brief overview: Window "Task Card" > Tab "Online Tools" > "SIRIUS Control Panel"
- Input action (Page 196)
- With a fieldbus via a 3RW5 communication module:
 - With SIRIUS Soft Starter ES (TIA Portal) Premium / Professional (only via a 3RW5 PROFINET or PROFIBUS communication module)
Brief overview: See SIRIUS Soft Starter ES (TIA Portal) via the local interface on the 3RW5 HMI High Feature
 - Configuration software of the control system (e.g. STEP 7 with corresponding HSP)
 - User program

You can find additional information on the parameters that can be set via the fieldbus in the manual of the respective 3RW5 communication module.

Setting via 3RW5 HMI High Feature

- Menu: "Parameters > Soft Starter > Parameter set 1 / 2 / 3 > Condition Monitoring > Pump cleaning"
- Access protection to the 3RW5 HMI High Feature is not active or has been reset.

Configuration of the system

If the 3RW55 or 3RW55 Failsafe soft starter detects a configured reversing contactor assembly, the 3RW55 or 3RW55 Failsafe soft starter automatically uses the "with reversing switching element" option (pump cleaning "intense") when starting the pump cleaning function. If the 3RW55 soft starter does not detect a configured reversing contactor assembly, it automatically uses the "with creep speed" option (pump cleaning "light"). In this case, the 3RW55 Failsafe soft starter cannot start the pump cleaning function.

Depending on the requirement for the pump cleaning function, note the information on the following pump applications:

Pump cleaning function with creep speed (Pump Cleaning "light")

This function is not available for the 3RW55 Failsafe soft starter.

This type of cleaning is suitable for preventing larger deposits of dirt. If the 3RW55 soft starter detects changes in the operational current, the cleaning can be started normally. There are, however, restrictions in this case. The pump cleaning function with creep speed can be operated in reversing mode only in the "Creep speed" (Page 174) function.

For the pump cleaning function with Creep speed, no further installations are required. You will find further information in the circuit example Pump cleaning function with creep speed (Page 320) and on the Internet under the FAQs (<https://support.industry.siemens.com/cs/ww/en/view/109761112>).

Pump cleaning function with reversing switching element (Pump Cleaning "intense")

This type of cleaning is capable of removing larger deposits of dirt on the impeller. For this purpose, another reversing contactor assembly is connected upstream of the 3RW55 or 3RW55 Failsafe soft starter in order to start the motor at full speed and with 100% torque in the opposite direction.

For the pump cleaning function with reversing switching element, further installations are required. You will find further information in the circuit example Pump cleaning function with reversing contactor (Page 322) and on the Internet under the FAQs (<https://support.industry.siemens.com/cs/ww/en/view/109761112>).

Diagram

The following diagram illustrates the sequence of a cycle:

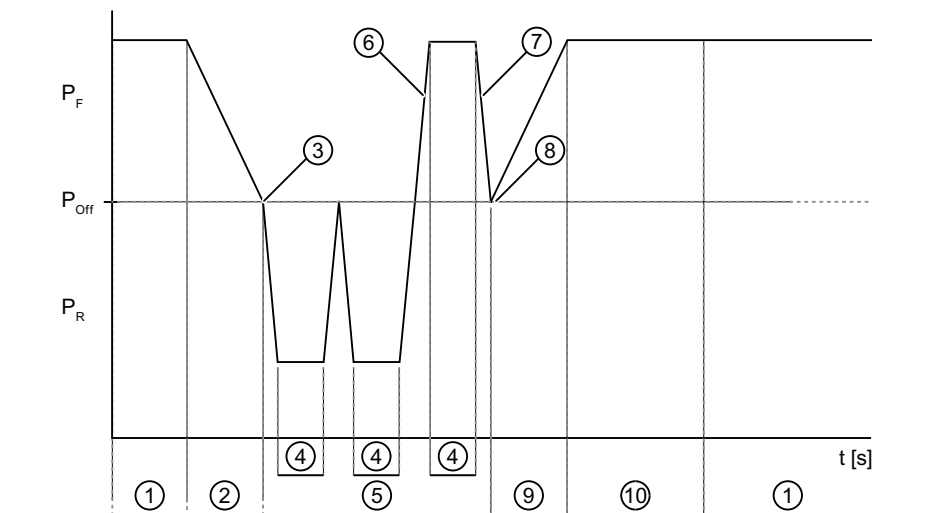

- ① Operation
 - ② Operation / stopping
 - ③ Start of the cleaning process with the set Pump cleaning - start/stop parameters
 - ④ Pump cleaning - time
 - ⑤ Pump cleaning - cycles
 - ⑥ Pump cleaning start
 - ⑦ Pump cleaning stop
 - ⑧ End of the cycle or end of the cleaning operation after the last cycle
 - ⑨ Operation starting
 - ⑩ Monitoring time (3 x pump cleaning - time)
 - ⑪ Pump cleaning active
- P_F Pump running forward
 P_{Off} Pump is off
 P_R Pump running in reverse

Parameters

Parameters	Description
Pump cleaning - mode	Deactivated (factory setting) The pump cleaning function is deactivated.
	Manual You can start and stop the pump cleaning function manually according to the activation options.

8.9 Asymmetry

Parameters	Description
Pump cleaning - time	<p>During the cleaning time, the pump runs at reduced speed and the maximum possible torque.</p> <ul style="list-style-type: none"> • Factory setting: 20 s • Setting range: 1 ... 30 s • In steps of: 1 s
Pump cleaning - cycles	<p>During a cycle, the pump rotation changes direction several times.</p> <p>For parameter values "Pump cleaning - cycles" > 1, the following applies: After completion of the cycle ⑧, the cleaning operation ③ is repeated until the set number of cycles is reached. The "Starting" ⑨ mode is then normally continued.</p> <ul style="list-style-type: none"> • Factory setting: 3 • Setting range: 1 ... 10 • In steps of: 1
Pump cleaning - start/stop parameters	<p>You can select the parameters for starting and stopping the pump for different cleaning processes here. For example, you can make different settings for starting and stopping in parameter set 2 than for the normal starting and stopping procedure.</p>
	<p>Parameter set 1</p> <p>The pump cleaning function is carried out with the starting and stopping parameters of parameter set 1.</p>
	<p>Parameter set 2</p> <p>The pump cleaning function is carried out with the starting and stopping parameters of parameter set 2.</p>
	<p>Parameter set 3</p> <p>The pump cleaning function is carried out with the starting and stopping parameters of parameter set 3.</p>
	<p>Operating parameters (factory setting)</p> <p>The pump cleaning function is carried out with the starting and stopping parameters of the currently selected parameter set.</p>

8.9 Asymmetry

Operating principle

In certain phases of the motor, an asymmetrical current consumption can cause a reduction in power or damage to the motor. Possible causes for this are a different line or phase voltage or an already damaged motor winding. The asymmetry monitoring monitors the 3 phase currents and issues a warning or switches the motor off at parameterizable limits. The current asymmetry can be displayed via the measured value "Asymmetry" (Page 229)

Setting options

- 3RW5 HMI High Feature
Menu: "Parameters > Soft Starter > Asymmetry"
Access protection to the 3RW5 HMI High Feature is not active or has been reset.
- With SIRIUS Soft Starter ES (TIA Portal) via the local interface on the 3RW5 HMI High Feature
Brief overview: Window "Project Navigation" with current project under created Soft Starter > "Parameters" > Window "Work area" > "Soft Starter > Asymmetry"
- With a fieldbus via a 3RW5 communication module:
 - With SIRIUS Soft Starter ES (TIA Portal) Premium / Professional (only via a 3RW5 PROFINET or PROFIBUS communication module)
Brief overview: See SIRIUS Soft Starter ES (TIA Portal) via the local interface on the 3RW5 HMI High Feature
 - Configuration software of the control system (e.g. STEP 7 with corresponding HSP)
 - User program

You can find additional information on the parameters that can be set via the fieldbus in the manual of the respective 3RW5 communication module.

Parameters

Parameters	Description
Asymmetry limit warning	If the asymmetry exceeds this limit, a warning is generated and the motor continues to run. The setting "0%" deactivates the limit value. <ul style="list-style-type: none"> • Factory setting: 0% • Limit: 10 ... 60% • In steps of: 5%
Asymmetry limit error	If the asymmetry exceeds this limit, an error is generated and the motor is switched off. The setting "0%" deactivates the limit value. <ul style="list-style-type: none"> • Factory setting: 30% • Limit: 10 ... 60% • In steps of: 5%

8.10 Ground fault

Operating principle

The "Ground fault" function of the 3RW55 and 3RW55 Failsafe soft starters measures and monitors all 3 phase currents. By evaluating the summation current of the 3 current values, the motor feeder can be monitored for a possible fault current or ground fault.

Setting options

- 3RW5 HMI High Feature
Menu: "Parameters > Soft Starter > Ground fault"
Access protection to the 3RW5 HMI High Feature is not active or has been reset.
- With SIRIUS Soft Starter ES (TIA Portal) via the local interface on the 3RW5 HMI High Feature
Brief overview: Window "Project Navigation" with current project under created Soft Starter > "Parameters" > Window "Work area" > "Soft Starter > Ground fault"
- With a fieldbus via a 3RW5 communication module:
 - With SIRIUS Soft Starter ES (TIA Portal) Premium / Professional (only via a 3RW5 PROFINET or PROFIBUS communication module)
Brief overview: See SIRIUS Soft Starter ES (TIA Portal) via the local interface on the 3RW5 HMI High Feature
 - Configuration software of the control system (e.g. STEP 7 with corresponding HSP)
 - User program

You can find additional information on the parameters that can be set via the fieldbus in the manual of the respective 3RW5 communication module.

Parameters

Parameters	Description
Ground fault limit warning	If the ground fault current in relation to the rated operational current I_e exceeds this limit, a warning is generated and the motor continues to run. The setting "0%" deactivates the monitoring of the limit value. <ul style="list-style-type: none"> • Factory setting: 0% • Limit: 10 ... 95% • In steps of: 5%
Ground fault limit error	If the ground fault current in relation to the rated operational current I_e exceeds this limit, an error is generated and the motor is shut off. The setting "0%" deactivates the monitoring of the limit value. <ul style="list-style-type: none"> • Factory setting: 20% • Limit: 10 ... 95% • In steps of: 5%

8.11 Emergency mode

8.11.1 Emergency start

Operating principle

The system can continue to be operated in the case of system faults with the "emergency start" function. This is necessary for systems in which the product becomes unusable without continued operation, e.g. glue and paint production. In crusher plants, in which a disconnection makes any further startup impossible in certain situations, continued operation is also necessary.

The emergency start is activated only if it has been enabled and a trip command exists due to a system fault. The motor is switched on by means of a normal control command.

NOTICE
Damage to the system
If the Emergency start function is activated, both system defects and system protection messages are ignored. This can cause further damage in the system.

In the case of some faults, the motor can be started via the "Emergency start" function despite a pending group error:

- Phase asymmetry limit exceeded
- Electronic motor overload protection
- Temperature sensor wire break
- Temperature sensor short-circuit
- Temperature sensor overload
- Maximum starting time exceeded
- I_e limit value exceeded/undershot
- Ground fault detected

Requirements

- Ex operation not active

Setting options

- 3RW5 HMI High Feature
Menu: "Parameters > Soft Starter > Emergency mode > Emergency start"
Access protection to the 3RW5 HMI High Feature is not active or has been reset.
- With SIRIUS Soft Starter ES (TIA Portal) via the local interface on the 3RW5 HMI High Feature
Brief overview: Window "Project Navigation" with current project under created Soft Starter > "Parameters" > Window "Work area" > "Soft Starter > Emergency mode"
- With a fieldbus via a 3RW5 communication module:
 - With SIRIUS Soft Starter ES (TIA Portal) Premium / Professional (only via a 3RW5 PROFINET or PROFIBUS communication module)
Brief overview: See SIRIUS Soft Starter ES (TIA Portal) via the local interface on the 3RW5 HMI High Feature
 - Configuration software of the control system (e.g. STEP 7 with corresponding HSP)
 - User program

You can find additional information on the parameters that can be set via the fieldbus in the manual of the respective 3RW5 communication module.

Parameters

Parameters	Description
Emergency start	Disable The "Emergency start" function is disabled. Activation of the emergency start is not possible.
	Manually enable/disable (factory setting) The "Emergency start" function can be enabled or disabled manually. In the event of device faults, intrinsic device protective shutdown, process mapping errors or stall protection, no emergency start is possible, even if emergency start has been enabled.

Activation options

If the "Emergency start" parameter is set to "Manually enable/disable", you can enable and disable the "Emergency start function" as follows:

- 3RW5 HMI High Feature
Menu: "Control > Enable Emergency start / stop"
Access protection to the 3RW5 HMI High Feature is not active or has been reset.
Refer to chapter Control via 3RW5 HMI High Feature (Page 234).
- With SIRIUS Soft Starter ES (TIA Portal) via the local interface on the 3RW5 HMI High Feature
Brief overview: Window "Task Card" > Tab "Online Tools" > "SIRIUS Control Panel"

- Input action (Page 196)

Note

If the control source is "Digital input", only a normally open contact may be connected to this input. A normally closed contact would result in activation of the emergency start in the event of a wire break.

- With a fieldbus via a 3RW5 communication module:
 - With SIRIUS Soft Starter ES (TIA Portal) Premium / Professional (only via a 3RW5 PROFINET or PROFIBUS communication module)
Brief overview: See SIRIUS Soft Starter ES (TIA Portal) via the local interface on the 3RW5 HMI High Feature
 - Configuration software of the control system (e.g. STEP 7 with corresponding HSP)
 - User program

You can find additional information on the parameters that can be set via the fieldbus in the manual of the respective 3RW5 communication module.

8.11.2 Emergency run

Operating principle

With the "Emergency run" function, the 3RW55 soft starter can continue to run with restricted functionality after failure of a power semiconductor. This avoids plant shutdown and ensures restricted operation of the motor and plant.

You set the behavior of the "Emergency run" function with the "Emergency run" parameter. The "Emergency run" function is disabled in the factory setting, making activation of the emergency run impossible. The "Emergency run" function can be enabled in every operating state. The function is not active before the failure of a power semiconductor and has no impact on the functions of the 3RW55 soft starter.

Effects of the emergency run on the 3RW55 soft starter

The 3RW55 soft starter makes parameter changes automatically when the emergency run (failure of a power semiconductor) is active. Parameter assignments and function settings that are not possible when the emergency run (failure of a power semiconductor) is active are not implemented by the 3RW55 soft starter. After the "Emergency run" function has been disabled (parameter) or deactivated (command / control command), the parameter assignments and function settings are implemented again. The following functions are not supported when the emergency run is active:

- Inside-delta circuit
- DC braking with external braking contactors
- Dynamic DC braking without contactor
- Reversing DC braking with a reversing contactor assembly
- Creep speed

8.11 Emergency mode

- Motor heating
- Operation at a rated operational voltage U_e of 690 V

The 3RW55 soft starter's intrinsic device protection remains active when an active emergency run (failure of a power semiconductor) is active. This ensures that no consequential damage arises due to use of the "Emergency run" function if the motor and the plant continue to be operated.

Application

- Avoiding unwanted plant standstills and failures

Validity

This function is not available for the 3RW55 Failsafe soft starter.

Requirements

- 3RW55 soft starter from firmware version V2.1
- Ex operation not active

Setting options

- 3RW5 HMI High Feature
Menu: "Parameters > Soft Starter > Emergency mode > Emergency run"
Access protection to the 3RW5 HMI High Feature is not active or has been reset.
- With SIRIUS Soft Starter ES (TIA Portal) via the local interface on the 3RW5 HMI High Feature
Brief overview: Window "Project Navigation" with current project under created Soft Starter > "Parameters" > Window "Work area" > "Soft Starter > Emergency mode"
- With a fieldbus via a 3RW5 communication module:
 - With SIRIUS Soft Starter ES (TIA Portal) Premium / Professional (only via a 3RW5 PROFINET or PROFIBUS communication module)
Brief overview: See SIRIUS Soft Starter ES (TIA Portal) via the local interface on the 3RW5 HMI High Feature
 - Configuration software of the control system (e.g. STEP 7 with corresponding HSP)
 - User program

You can find additional information on the parameters that can be set via the fieldbus in the manual of the respective 3RW5 communication module.

Parameter

Parameter	Description
Emergency run	<p>Disable (factory setting)</p> <p>The "Emergency run" function is disabled. Activation of the emergency run is not possible. If the 3RW55 soft starter detects a failed power semiconductor, it generates an error with trip command and the message text "Switching element L* failed".</p>
	<p>Manually enable/disable</p> <p>The "Emergency run" function can be manually enabled or disabled using command / control command.</p> <ul style="list-style-type: none"> Manual enabling following failure of a power semiconductor: If the 3RW55 soft starter detects a failed power semiconductor, it generates an error with trip command and the message text "Switching element L* failed". You can use the command / control command "Enable emergency run" (Page 234) to activate the emergency run. Activation of the emergency run results in the error being acknowledged and the 3RW55 soft starter switches back into the previously active operating state. The active emergency run is accompanied by a warning with the following message text "2-phase control with defective thyristor active". Manual enabling prior to failure of a power semiconductor: In the event of the failure of a power semiconductor, the 3RW55 soft starter responds in the same way as when the "Emergency run" parameter is set to "Enabled". <p>An active emergency run (failure of a power semiconductor) is not stored with non-volatile tripping status in the 3RW55 soft starter. The emergency run remains active until the command / control command is revoked ("Disable emergency run"), the "Emergency run" function (parameter) is deactivated or the supply voltage (control supply voltage) is switched off.</p>
	<p>Enable</p> <p>The "Emergency run" function is enabled. If the 3RW55 soft starter detects a failed power semiconductor, the emergency run is activated automatically and the 3RW55 soft starter generates a warning with the message text "2-phase control with defective thyristor active".</p> <p>If the motor is starting during the failure of a power semiconductor, starting is aborted and the motor restarted with a 2-phase control. This can effect the motor by causing bucking or a drop in operating speed.</p> <p>If the motor is in run-down during the failure of a power semiconductor, the run-down is terminated with the stopping mode "Coasting down". Only then can the stopping modes "Voltage ramp", "Torque control" or "Pump stopping mode" be parameterized again. If one of the 3 DC braking modes is parameterized as the stopping mode, the 3RW55 soft starter alternatively uses the stopping mode "Coasting down".</p> <p>The active emergency run (failure of a power semiconductor) is not stored with non-volatile tripping status in the 3RW55 soft starter. The emergency run remains active until the function is disabled or the failed power semiconductor has been replaced.</p>

Activation options

If the "Emergency run" parameter is set to "Manually enable/disable", you can activate and deactivate the emergency run in the event of a failed power semiconductor as follows:

- 3RW5 HMI High Feature
Menu: "Control > Enable / Disable emergency run"
Access protection to the 3RW5 HMI High Feature is not active or has been reset.
Refer to chapter Control via 3RW5 HMI High Feature (Page 234).
- With SIRIUS Soft Starter ES (TIA Portal) via the local interface on the 3RW5 HMI High Feature
Brief overview: Window "Task Card" > Tab "Online Tools" > "SIRIUS Control Panel"
- With a fieldbus via a 3RW5 communication module:
 - With SIRIUS Soft Starter ES (TIA Portal) Premium / Professional (only via a 3RW5 PROFINET or PROFIBUS communication module)
Brief overview: See SIRIUS Soft Starter ES (TIA Portal) via the local interface on the 3RW5 HMI High Feature
 - Configuration software of the control system (e.g. STEP 7 with corresponding HSP)
 - With the commands "Enable emergency run" or "Disable emergency run" in data record 93You can find additional information on the parameters that can be set via the fieldbus in the manual of the respective 3RW5 communication module.

8.12 Inputs

8.12.1 Overview of the input functions

Operating principle

The 3RW55 and 3RW55 Failsafe soft starters have 4 digital inputs DI1 ... DI4 to which you can assign an input action. The 3RW55 Failsafe soft starter also has a failsafe digital input (F-DI). This input cannot be parameterized.

Inputs with the input actions "Motor CW with PSx" or "Motor CCW with PSx" have AND connection. If multiple inputs are assigned the same input action (e.g. Input 1 and Input 2 are assigned the input action "Motor CW with PS1"), all of these inputs have to be activated for the start command to be accepted.

Inputs with other input actions have OR connections. If multiple inputs are assigned the same input action (e.g. Input 1 and Input 2 are assigned the input action "Emergency start"), only one of these inputs has to be activated for the function to be executed.

Requirements

You can only modify an input action if the relevant input is not active.

Setting options

- 3RW5 HMI High Feature
Menu: "Parameters > Soft Starter > Inputs"
Access protection to the 3RW5 HMI High Feature is not active or has been reset.
- With SIRIUS Soft Starter ES (TIA Portal) via the local interface on the 3RW5 HMI High Feature
Brief overview: Window "Project Navigation" with current project under created Soft Starter > "Parameters" > Window "Work area" > "Soft Starter > Inputs"
- With a fieldbus via a 3RW5 communication module:
 - With SIRIUS Soft Starter ES (TIA Portal) Premium / Professional (only via a 3RW5 PROFINET or PROFIBUS communication module)
Brief overview: See SIRIUS Soft Starter ES (TIA Portal) via the local interface on the 3RW5 HMI High Feature
 - Configuration software of the control system (e.g. STEP 7 with corresponding HSP)
 - User program

You can find additional information on the parameters that can be set via the fieldbus in the manual of the respective 3RW5 communication module.

Parameters

Input action		Description	Factory setting			
			DI1	DI2	DI3	DI4
No action		Input has no function.	-	x	x	-
Operating mode manual - local		You can only control the 3RW55 or 3RW55 Failsafe soft starter locally via the local interface, the 3RW5 HMI High Feature or via the digital inputs.	-	-	-	-
Emergency start		In the case of some errors, the motor can be started via the "Emergency start" function despite a pending group error: One input is assigned the action "Emergency start" and a further input, for example the action "Motor CW with Parameter set 1". The emergency start is active as long as the input is activated. The emergency start can also be activated during operation. You will find more information in chapter Emergency start (Page 191).	-	-	-	-
Creep speed ¹⁾		The motor starts with the values set in the "Creep speed parameters" menu item when the "Creep speed" input and the "Motor CW/CCW with Parameter set 1/2/3" input are activated at the same time. You will find more information in chapter Creep speed (Page 174).	-	-	-	-
Quick-stop		If the input is activated, normal tripping of the motor with the currently set stopping function is executed. You will find more information in chapter Quick-stop (Page 176).	-	-	-	-
Reset		You can acknowledge the fault after it has been remedied. The "Reset" input is edge-controlled. The level change from 0 to 24 V DC is evaluated at the input. All other input functions are evaluated at the already pending 24 V DC level. You will find more information in chapter Reset (Page 175).	-	-	-	x
Motor CW	with parameter set 1	The motor starts with rotation in line phase direction and stops with the values stored in the respective parameter set.	x	-	-	-
	with parameter set 2		-	-	-	-
	with parameter set 3		-	-	-	-

8.12 Inputs

Input action		Description	Factory setting			
			DI1	DI2	DI3	DI4
Motor CCW	with parameter set 1	This function is active only when the "Creep speed" parameter or reversing mode with external reversing switching elements is active at the same time. The motor starts with the values stored in the "Creep speed parameters" menu item (with rotation opposite to the line phase direction).	-	-	-	-
	with parameter set 2		-	-	-	-
	with parameter set 3		-	-	-	-
Motor standstill ¹⁾		The 3RW55 soft starter evaluates the signal from an external motor standstill detection at the input. You will find more information in chapter External motor standstill detection (Page 165).	-	-	-	-
Use alternative stopping mode		You will find more information in chapter Alternative stopping (Page 165).	-	-	-	-
Start pump cleaning		You will find more information in chapter Pump cleaning function (Page 184).	-	-	-	-

¹⁾ Input action is not available for the 3RW55 Failsafe soft starter.

8.12.2 Process data and process images

The basic functions of the 3RW55 and 3RW55 Failsafe soft starters are controlled and monitored in the process data in the process images.

The process images can be transferred as follows:

- Cyclically in the fieldbus protocol
- Acyclically using data sets

Process image input (PII) and process image output (PIQ)

The following process images are transferred:

- Process image input with 16 bytes
- Process image output with 4 bytes

The tables for the process images describe only the supported process data. Inputs and outputs that are not listed are not assigned.

Process image input (PII)

Process data	Process image
DI 0.0	Ready (automatic)
DI 0.1	Motor On
DI 0.2	Group error
DI 0.3	Group warning
DI 0.4	Input 1
DI 0.5	Input 2

Process data	Process image	
DI 0.6	Input 3	
DI 0.7	Input 4	
DI 1.0	Motor current lact-bit0	
DI 1.1	Motor current lact-bit1	
DI 1.2	Motor current lact-bit2	
DI 1.3	Motor current lact-bit3	
DI 1.4	Motor current lact-bit4	
DI 1.5	Motor current lact-bit5	
DI 1.6	Operating mode manual - local	
DI 1.7	Ramp operation	
DI 2.0	Motor CW	
DI 2.1	Motor CCW	
DI 2.4	Starting mode active	
DI 2.5	Operation / bypass active	
DI 2.6	Stopping mode active	
DI 2.7	Test mode active	
DI 3.0	Thermal motor model overload	
DI 3.1	Temperature sensor overload	
DI 3.2	Switching element overload	
DI 3.3	Cooling time active	
DI 3.4	Device error	
DI 3.5	Automatic parameterization active	
DI 3.6	New Ex parameter values detected ¹⁾	
AI 4 (Float32)	Measured value 1	You will find further information on the settable measured values in chapter Cyclic send data (Page 207).
AI 8 (Float32)	Measured value 2	
AI 12 (Float32)	Measured value 3	

¹⁾ 3RW55 soft starter from firmware version V2.0 or 3RW55 Failsafe soft starter from firmware version V1.0

Process image output (PIQ)

Process data	Process image
DQ 0.0	Motor CW
DQ 0.1	Motor CCW
DQ 0.3	Reset ¹⁾
DQ 0.4	Emergency start ²⁾
DQ 0.5	Self-test (user-test)
DQ 0.6	Creep speed ³⁾
DQ 1.0	Output 1 ^{4), 5)}
DQ 1.1	Output 2 ^{4), 5)}
DQ 1.2	Parameter set bit 0 ⁶⁾
DQ 1.3	Parameter set bit 1 ⁶⁾

8.13 Outputs

Process data	Process image
DQ 1.7	Disable Quick-stop
DQ 2.0	Output 3 ^{3), 4)}
DQ 2.3	Start pump cleaning
DQ 3.0	Manual operation local - Input controlled
DQ 3.1	Use alternative stopping mode
DQ 3.2	Motor standstill ³⁾

- 1) In order to perform the reset reliably, the control command "Reset" must be present for at least 20 ms.
- 2) Control data is relevant for Ex applications.
- 3) This function is not available for the 3RW55 Failsafe soft starter.
- 4) You can assign the control data "Output 1", "Output 2" and "Output 3" to the digital outputs 1, 2 and 4 of the 3RW55 soft starter in any order via the digital output actions.
- 5) You can assign the control data "Output 1" and "Output 2" to the digital outputs 1 and 2 of the 3RW55 Failsafe soft starter in any order via the digital output actions.
- 6) Explanation in the following table.

Additional information

The following table describes the assignment of the process images "Parameter set bit 0" and "Parameter set bit 1":

Assignment of the PIQ bits	Parameter set bit 0	Parameter set bit 1
Process image error	1	1
Parameter set 1 (PS1)	0	0
Parameter set 2 (PS2)	1	0
Parameter set 3 (PS3)	0	1

8.13 Outputs

8.13.1 Digital outputs

Operating principle

The 3RW55 and 3RW55 Failsafe soft starters have 4 digital outputs (DQ1 = output 13, 14; DQ2 = output 23, 24; DQ3 = output 95, 96, 98; DQ4 = output 43, 44 or output 41, 42 (F-RQ)) (Page 73) with which external actuators such as a brake contactor or indicator lamp can be activated.

Using the output actions, you can assign an output action to the digital outputs. Digital output 3 is permanently assigned to the output action "Group error". The 3RW55 Failsafe soft starter has a safety signaling output (output 4, F-RQ) (Page 75). This output cannot be parameterized. The remaining outputs of the 3RW55 and 3RW55 Failsafe soft starters can be assigned an output action independently of one another.

State diagram of the outputs

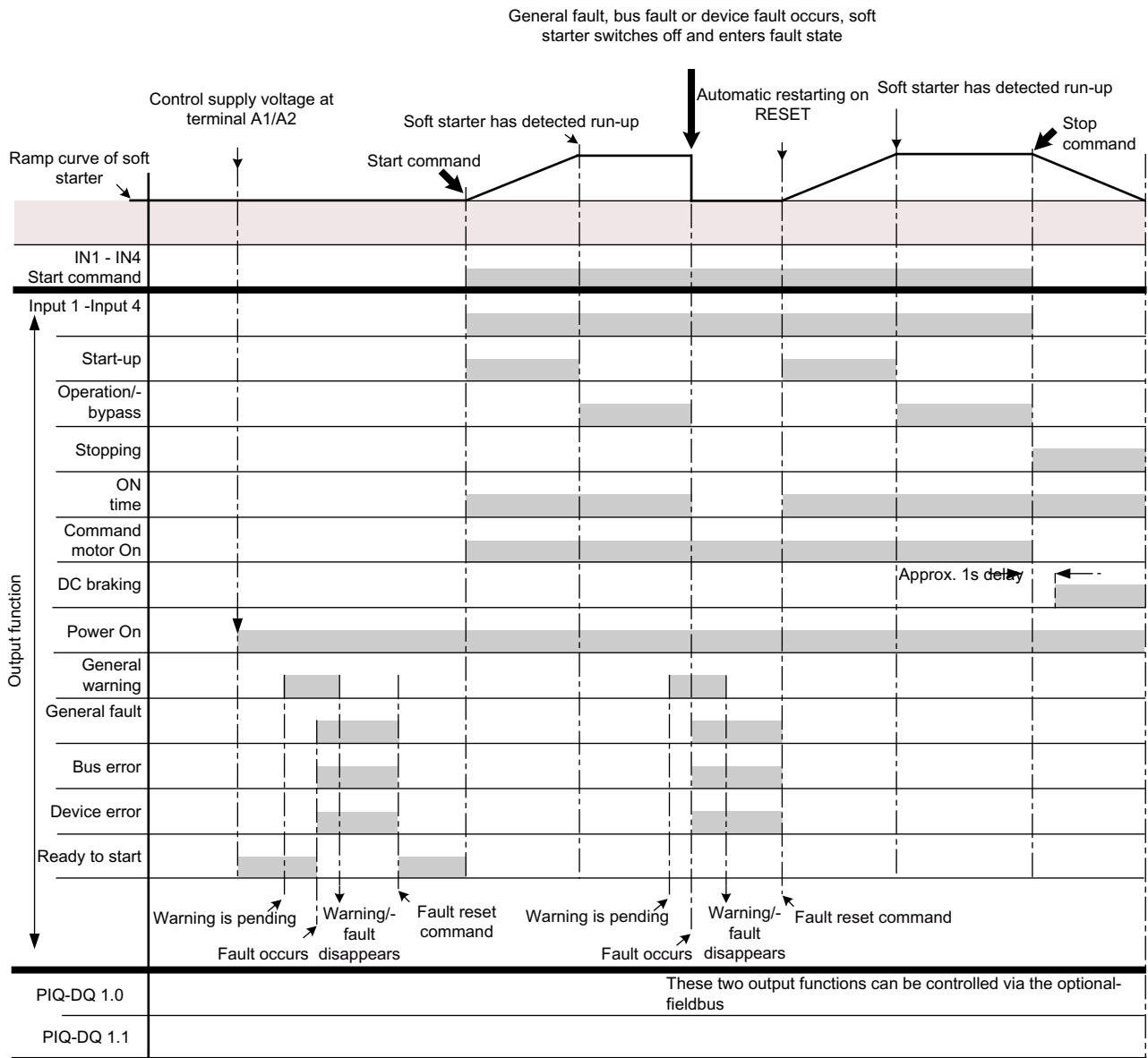

Setting options

- 3RW5 HMI High Feature
Menu: "Parameters > Soft Starter > Outputs"
Access protection to the 3RW5 HMI High Feature is not active or has been reset.
- With SIRIUS Soft Starter ES (TIA Portal) via the local interface on the 3RW5 HMI High Feature
Brief overview: Window "Project Navigation" with current project under created Soft Starter > "Parameters" > Window "Work area" > "Soft Starter > Outputs > Soft Starter"
- With a fieldbus via a 3RW5 communication module:
 - With SIRIUS Soft Starter ES (TIA Portal) Premium / Professional (only via a 3RW5 PROFINET or PROFIBUS communication module)
Brief overview: See SIRIUS Soft Starter ES (TIA Portal) via the local interface on the 3RW5 HMI High Feature
 - Configuration software of the control system (e.g. STEP 7 with corresponding HSP)
 - User program

You can find additional information on the parameters that can be set via the fieldbus in the manual of the respective 3RW5 communication module.

Parameter - Delay

Parameters	Description
ON delay time	The switching of the output is delayed by this time. <ul style="list-style-type: none"> • Factory setting: 0 s • Setting range: 0 ... 6 500 s • In steps of: 0.1 s
OFF delay time	

Parameter - Output action

Output action	Description	Factory setting			
		DQ1	DQ2	DQ3 ¹⁾	DQ4 ²⁾
No action	-	-	x	-	x
Activation by external control sources					
Control source PIQ-DQ-1.0 output 1	The control command "Output 1" is assigned to the corresponding digital output. Refer to chapter Control via 3RW5 HMI High Feature (Page 234).	-	-	-	-
Control source PIQ-DQ-1.1 output 2	The control command "Output 2" is assigned to the corresponding digital output. Refer to chapter Control via 3RW5 HMI High Feature (Page 234).	-	-	-	-
Control source PIQ-DQ-2.0 output 3 ³⁾	The control command "Output 3" is assigned to the corresponding digital output. Refer to chapter Control via 3RW5 HMI High Feature (Page 234).	-	-	-	-
Control source input 1	Digital output is activated by "Digital input 1".	-	-	-	-

Output action	Description	Factory setting			
		DQ1	DQ2	DQ3 ¹⁾	DQ4 ²⁾
Control source input 2	Digital output is activated by "Digital input 2".	-	-	-	-
Control source input 3	Digital output is activated by "Digital input 3".	-	-	-	-
Control source input 4	Digital output is activated by "Digital input 4".	-	-	-	-
Activation by means of soft starter					
Start-up	For further information, refer to the diagram in chapter Operating principle (Page 27).	-	-	-	-
Operation / bypass		-	-	-	-
Stopping		-	-	-	-
On time motor (RUN)		x	-	-	-
Operation / Run-down		-	-	-	-
Control command MOTOR ON (ON)	The output is activated for as long as the control command "Motor CW" or "Motor CCW" is present.	-	-	-	-
DC brake contactor ³⁾	The output action controls a DC braking contactor via this output. You will find more information in chapter DC braking with external braking contactors (Page 156).	-	-	-	-
Device ON	The output is active for as long as the electronic supply is present at the 3RW55 or 3RW55 Failsafe soft starter.	-	-	-	-
Activation by signals from the soft starter					
Group warning	Group signals	-	-	-	-
Group error		-	-	x	-
Bus error		-	-	-	-
Device error		-	-	-	-
Reversing switching element - right	The internal control signal for the reversing function is assigned to the corresponding digital output of the soft starter.	-	-	-	-
Reversing switching element - left		-	-	-	-
Generator operation	Status messages	-	-	-	-
Ready to start for motor ON		-	-	-	-
Pump cleaning active		-	-	-	-
Alternative stopping mode active		-	-	-	-
External bypass ^{3), 4)}		-	-	-	-
CM - maintenance demanded		-	-	-	-
CM - error		-	-	-	-

1) Permanently set to the output action "Group error".

2) For 3RW55 Failsafe soft starters, this is the safety signaling output (output 4, F-RQ). This output cannot be parameterized.

3) Output action is not available for the 3RW55 Failsafe soft starter.

4) 3RW55 soft starter from firmware version V2.0

8.13.2 Analog output

Operating principle

The set measured value is displayed via the analog output using an external evaluation unit. Depending on the respective connecting terminal being used, the signal can be displayed either as current or voltage.

- Terminals: AQ- / AQ I+
Measuring range of current output: 4 - 20 mA
- Terminals: AQ- / AQ U+
Measuring range of voltage output: 0 - 10 V

Requirements

Evaluation unit is connected properly (Page 306).

Setting options

- 3RW5 HMI High Feature
Menu: "Parameters > Soft Starter > Outputs > Analog output"
Access protection to the 3RW5 HMI High Feature is not active or has been reset.
- With SIRIUS Soft Starter ES (TIA Portal) via the local interface on the 3RW5 HMI High Feature
Brief overview: Window "Project Navigation" with current project under created Soft Starter > "Parameters" > Window "Work area" > "Soft Starter > Outputs > Soft Starter > Analog output"
- With a fieldbus via a 3RW5 communication module:
 - With SIRIUS Soft Starter ES (TIA Portal) Premium / Professional (only via a 3RW5 PROFINET or PROFIBUS communication module)
Brief overview: See SIRIUS Soft Starter ES (TIA Portal) via the local interface on the 3RW5 HMI High Feature
 - Configuration software of the control system (e.g. STEP 7 with corresponding HSP)
 - User program

You can find additional information on the parameters that can be set via the fieldbus in the manual of the respective 3RW5 communication module.

Parameters

Parameters	Description
Output signal type	<p>Via the "Output signal type" parameter, you can define with what type of signal the analog value will be output (current or voltage).</p> <ul style="list-style-type: none"> Deactivated (factory setting) 4 ... 20 mA 0 ... 10 V
Measured value	<p>Select the measured value to be transferred from the analog output via the "Measured value" parameter.</p> <ul style="list-style-type: none"> Deactivated Phase current I L1 (%) Phase current I L2 (%) Phase current I L3 (%) Phase current average (%) Phase current I L1 (rms) Phase current I L2 (rms) Phase current I L3 (rms) Phase current average (rms) Line voltage U L1-L2 (rms) Line voltage U L2-L3 (rms) Line voltage U L3-L1 (rms) Active power Power factor L1...3 Active energy import (total) Motor temperature rise Switching element heating <p>You will find further information in chapter "Monitoring the measured values of the 3RW55 soft starter with the 3RW5 HMI High Feature (Page 229)".</p>
Range start value	<p>With parameters "Range start value" and "Range end value", you can define which value of the analog value to be output corresponds to the lower output signal value and which to the upper output signal value. The corresponding value depends on the coding of the measured value to be transferred (Unsigned 32).</p> <ul style="list-style-type: none"> Setting of the analog range, e.g. 4 mA = 100 Setting of the analog range, e.g. 20 mA = 400
Range end value	

Factors for calculating the output measured value

Measured value	Factor	Unit	Range of values	Coding
<ul style="list-style-type: none"> Phase current I L1 (%) Phase current I L2 (%) Phase current I L3 (%) Phase current average (%) 	3.125	%	0 ... 796.9%	0 ... 255
<ul style="list-style-type: none"> Motor temperature rise 	1	%	0 ... 1 000%	0 ... 1 000
<ul style="list-style-type: none"> Switching element heating 	1	%	0 ... 250%	0 ... 250
<ul style="list-style-type: none"> Line voltage U L1-L2 (rms) Line voltage U L2-L3 (rms) Line voltage U L3-L1 (rms) 	0.1	V	0 ... 1 500 V	0 ... 15 000
<ul style="list-style-type: none"> Phase current I L1 (rms) Phase current I L2 (rms) Phase current I L3 (rms) Phase current average (rms) 	0.01	A	0 ... 20 000 A	0 ... 2 000 000
<ul style="list-style-type: none"> Power factor L1...3 	0.01	-	0 ... 1	0 ... 100
<ul style="list-style-type: none"> Active power 	0.0001	kW	0 ... 2 147.483 kW	0 ... 21 474 830
<ul style="list-style-type: none"> Active energy import (total) 	1	Wh	0 ... 3.4 x 10 ³⁸ Wh	0 ... 3.4 x 10 ³⁸ (float 32)

Example of calculating the parameters for the range start value and range end value

In this example, a pointer instrument indicates the measured value "Phase current I L1 (rms)" 50 A (start value) at the left stop and 150 A (end value) at the right stop. You can divide the scale of the pointer instrument between the left stop and the right stop, depending on the desired resolution.

The following measured values and parameters are given as examples at this point:

- Output signal type: 4 ... 20 mA
- Measured value: Phase current I L1 (rms)
- Range start value = desired start value (e.g. 50 A) / factor of the measured value in question
- Range end value = desired end value (e.g. 150 A) / factor of the measured value in question

Procedure

1. Parameterize the output signal type, e.g. 4 ... 20 mA.
2. Select a measured value, e.g.: Phase current I L1 (rms)
3. Parameterize the range start value and the range end value taking the relevant factor into account:
 - Range start value (e.g. 50 A / 0.01 A) → 5 000
 - Range end value (e.g. 150 A / 0.01 A) → 15 000

Result

You have adjusted the output signal of the analog output.

PLC at analog output

You can connect the analog output of the 3RW55 and 3RW55 Failsafe soft starters to a free analog input of the PLC. Make sure that the analog input of the PLC is not connected to the supply voltage (control supply voltage) of the 3RW55 or 3RW55 Failsafe soft starter and is floating.

8.13.3 Cyclic send data

Operating principle

In the process image input (PII) (Page 198), 3 measured values are transferred that you can parameterize.

Setting options

- 3RW5 HMI High Feature
Menu: "Parameters > Soft Starter > Outputs > Cyclic send data"
Access protection to the 3RW5 HMI High Feature is not active or has been reset.
- With SIRIUS Soft Starter ES (TIA Portal) via the local interface on the 3RW5 HMI High Feature
Brief overview: Window "Project Navigation" with current project under created Soft Starter > "Parameters" > Window "Work area" > "Soft Starter > Outputs > Cyclic send data"
- With a fieldbus via a 3RW5 communication module:
 - With SIRIUS Soft Starter ES (TIA Portal) Premium / Professional (only via a 3RW5 PROFINET or PROFIBUS communication module)
Brief overview: See SIRIUS Soft Starter ES (TIA Portal) via the local interface on the 3RW5 HMI High Feature
 - Configuration software of the control system (e.g. STEP 7 with corresponding HSP)
 - User program

You can find additional information on the parameters that can be set via the fieldbus in the manual of the respective 3RW5 communication module.

Parameters

Parameters	Description
Measured value 1	For "Measured value 1", "Measured value 2" and "Measured value 3" specify one measured value in each case:
Measured value 2	
Measured value 3	

8.14 ATEX/IECEX/UKEX

8.14.1 ATEX/IECEX/UKEX-certified motor overload protection

Observe the safety instructions in chapter ATEX/IECEX/UKEX (Page 18).

8.14.2 Ex operation

Requirements

! DANGER

**Loss of certified motor overload protection according to ATEX/IECEX/UKEX.
Can cause death or serious injury.**

Note that operation of a 3RW55 soft starter in the motor connection type "Standard" without implementing one of the two following remedial measures for the following line voltages results in loss of certified motor overload protection according to ATEX/IECEX/UKEX (does not apply to 3RW55 Failsafe soft starters):

- Soft starter 200 - 480 V: for line voltage > 440 V (+10%)
- Soft starter 200 - 600 V: for line voltage > 500 V (+10%)
- Soft starter 200 - 690 V: for line voltage > 560 V (+10%)

Depending on the circuit design, choose one of the following possibilities for ensuring certified motor overload protection according to ATEX/IECEX/UKEX:

- Use an additional line contactor in the main circuit.
Connect the line contactor at outputs 95, 96 and 98 (output 3).
You will find more information in chapter Type of motor connection "Standard" (inline) in Ex operation (Page 307).
- For a motor feeder configuration with a circuit breaker, use an additional undervoltage trip unit.
Connect the undervoltage trip unit at outputs 95, 96 and 98 (output 3).
You will find more information in chapter Connecting (Page 73).

! DANGER

**Loss of certified motor overload protection according to ATEX/IECEX/UKEX.
Can cause death or serious injury.**

Note that operation of a 3RW55 or 3RW55 Failsafe soft starter with motor connection type "Inside-delta" without implementing one of the two following remedial measures results in loss of certified motor overload protection according to ATEX/IECEX/UKEX:

Depending on the circuit design, choose one of the following possibilities for ensuring certified motor overload protection according to ATEX/IECEX/UKEX:

- Use an additional line contactor in the main circuit (in the supply cable or in the delta connection).
Connect the line contactor at outputs 95, 96 and 98 (output 3).
You will find more information in chapter Type of motor connection "inside delta" in Ex operation (Page 309).
- For a motor feeder configuration with a circuit breaker, use an additional undervoltage trip unit.
Connect the undervoltage trip unit at outputs 95, 96 and 98 (output 3).
You will find more information in chapter Connecting (Page 73).

- 3RW55 soft starter from firmware version V2.0 and product version E02 or 3RW55 Failsafe soft starter
- Micro SD card (Page 245)
- 3RW5 HMI High Feature
Menu "Parameters > Soft Starter > Ex operation"

If you are operating the motor in Class I and Class II Hazardous Locations:

- If an Ex motor is protected, only parameter set 1 is active even if another parameter set is selected. Parameter sets 2 and 3 are not available in this case.

Temperatures on the motor

- Make sure that the limit temperature of the winding insulation is not exceeded.
- Make sure that the maximum temperature of the motor is below the locally critical minimum ignition temperature.
- Make sure that the explosion protection is ensured for operation of motors in the hazardous area.

Operating principle

The "Ex application" function supports you with parameterization of the 3RW55 or 3RW55 Failsafe soft starter if you are operating a motor in Class I and Class II Hazardous Locations. You can choose which of the following motor protection functions is used to protect the motor:

- Complete motor protection
- Electronic motor overload protection
- Thermistor motor protection with temperature sensor

You must confirm each setting of Ex relevant parameters on the 3RW5 HMI High Feature. This prevents settings relevant to explosion protection from being corrupted during transmission. This also ensures that the parameter changes were set on the correct 3RW55 or 3RW55 Failsafe soft starter and the requirements of common standards and regulations are met.

The 3RW55 and 3RW55 Failsafe soft starters continue to work with the parameters that were last active until you confirm the newly set parameters.

Note

Appearance of the text file and the Ex relevant parameters on the 3RW5 HMI High Feature

Note that the text file for logging the new Ex parameters in the 3RW5 HMI High Feature is only shown in English.

For simpler comparison of the parameter settings logged in the text file with the Ex relevant parameters to be enabled, the Ex-relevant parameters are shown in English.

As soon as the Ex relevant parameters are enabled, these parameters will appear in the set language of the 3RW5 HMI High Feature again.

Procedure

1. Make sure that a micro SD card is in the slot of the 3RW5 HMI High Feature.
2. Set the "Ex application" parameter and the corresponding parameters in the "Ex relevant parameters" menu.
3. Exit the "Ex operation" menu with the ESC key.
A popup window appears in the display of the 3RW5 HMI High Feature. The LEDs on the 3RW55 and 3RW55 Failsafe soft starters indicate that the device is waiting for confirmation of the Ex-relevant parameters. You will find more information in chapter LED display and displays on the HMI High Feature (Page 249).
4. Confirm the menu entry "Load Ex parameterization to micro SD card" with the OK key.
The 3RW5 HMI High Feature generates a text file in English ("txt" file format) in which the new parameter settings are logged. This text file is stored on the micro SD card in the 3RW5 HMI High Feature.
5. Check the parameter settings in the text file, e.g. on a PC.
 - If the parameter settings are correct, confirm the menu item "Confirm Ex parameters" on the 3RW5 HMI High Feature with the OK key. The parameters will be saved.
 - If the parameter settings contain any errors, confirm the menu item "Discard Ex parameters" on the 3RW5 HMI High Feature with the OK key and set the parameters again.
6. Check confirmation of the Ex-relevant parameters on the device LEDs on the 3RW55 or 3RW55 Failsafe soft starter. You will find more information in chapter LED display and displays on the HMI High Feature (Page 249).

Parameters

DANGER

**Explosion danger in Class I and Class II Hazardous Locations.
Can cause death or serious injury.**

The components of the 3RW55 and 3RW55 Failsafe soft starters are not suitable for installation in Class I and Class II Hazardous Locations

Only ever use the device in a control cabinet with at least degree of protection IP 4x.

Observe the safety instructions in chapter ATEX/IECEX/UKEX-certified motor overload protection (Page 18).

If you have any questions, ask your ATEX/IECEX/UKEX expert.

Parameters	Description
Ex application	<p>No (factory setting) All ATEX/IECEX/UKEX-specific function restrictions are not active. Ex parameter is not displayed.</p>
	<p>Yes, with complete motor protection</p> <ul style="list-style-type: none"> Both motor protection functions of the 3RW55 and 3RW55 Failsafe soft starters (electronic motor overload protection and thermistor motor protection with temperature sensor) are implemented in a safety-related manner.
	<p>Yes, with motor overload protection</p> <ul style="list-style-type: none"> Only the motor protection function "Electronic motor overload protection" is implemented in a safety-related manner. The motor protection function "Thermistor motor protection with Temperature sensor" is not implemented in a safety-related manner.
	<p>Yes, with thermistor motor protection with temperature sensor</p> <ul style="list-style-type: none"> Only the motor protection function "Thermistor motor protection with Temperature sensor" is implemented in a safety-related manner. The motor protection function "Electronic motor overload protection" is not implemented in a safety-related manner.
Ex relevant parameters ¹⁾ (Ex-relevant parameters ¹⁾)	<p>Rated operational current I_e Set the 3RW55 or 3RW55 Failsafe soft starters to the rated operational current of the motor as stated on the type plate or design test certificate of the motor. The 3RW5 HMI High Feature shows the value to be enabled in parentheses.</p>
	<p>Tripping class (or trip class) Make sure that the motor and the cables are dimensioned for the selected trip class. The rated data of the 3RW55 and 3RW55 Failsafe soft starters refers to normal starting (CLASS 10E). For heavy starting (> CLASS 10E), you may have to overdimension the 3RW55 or 3RW55 Failsafe soft starter because you can only set an operational current of the motor that is lower than the operational current of the soft starter. The 3RW5 HMI High Feature shows the value to be enabled in parentheses.</p>
	<p>Recovery time Set the recovery time. The 3RW5 HMI High Feature shows the value to be enabled in parentheses.</p>
	<p>Motor connection type Set the motor connection type. The 3RW5 HMI High Feature shows the motor connection type to be enabled in parentheses.</p>
	<p>Ex application</p>

¹⁾ This parameter is displayed and can be set depending on the chosen Ex application.

Selection of the motor protection function

Selection of the motor protection function in question influences the parameterization. If the "Ex application" is activated, impermissible settings of the ATEX/IECEX/UKEX-relevant parameters are deactivated and therefore prevented. The following parameters are ATEX/IECEX/UKEX-relevant:

The following parameters must be set and confirmed by you:

Parameters	Relevant for parameter "Ex application: Yes, with ..."		
	Complete motor protection	Electronic motor overload protection	Thermistor motor protection with temperature sensor
Ex application	selectable	selectable	selectable
Rated operational current I_e	selectable	selectable	not selectable
Trip class	selectable	selectable	not selectable
Recovery time	selectable	selectable	not selectable
Motor connection type	selectable	selectable	not selectable

Automatic setting by the 3RW55 and 3RW55 Failsafe soft starters:

Parameters	Relevant for parameter "Ex application: Yes, with ..."		
	Complete motor protection	Electronic motor overload protection	Thermistor motor protection with temperature sensor
General			
Creep speed ¹⁾	selectable ²⁾	not selectable	selectable ²⁾
Emergency start		not selectable	
Emergency run ¹⁾		not selectable	
Non-volatile tripping status		Yes (fixed value)	
Parameter set 1		active (fixed value)	
Typical ambient temperature		60°C (fixed value)	
Bypass operating mode		Internal bypass (fixed value)	
Electronic motor overload protection			
Service factor		100% (fixed value)	selectable ¹⁾
Response to overload thermal motor model		Turn off without restart (fixed value)	selectable ¹⁾
Thermistor motor protection with temperature sensor			
Temperature sensor	PTC type A (fixed value)	selectable ¹⁾	PTC type A (fixed value)
Response to overload temperature sensor	Turn off without restart (fixed value)	selectable ¹⁾	Turn off without restart (fixed value)

¹⁾ Parameter not available for the 3RW55 Failsafe soft starter.

²⁾ The parameter is not ATEX/IECEX/UKEX-relevant in this combination and can be set in the relevant menu.

Restriction of the possible parameters:

Parameters	Relevant for parameter "Ex application: Yes, with ..."		
	Complete motor protection	Electronic motor overload protection	Thermistor motor protection with temperature sensor
Starting mode			
Motor heating ¹⁾	selectable	not selectable	selectable
Stopping mode / Alternative stopping mode			
DC braking ¹⁾	selectable	not selectable	selectable
Dynamic DC braking ¹⁾	selectable	not selectable	selectable
Reversing DC braking ¹⁾	selectable	not selectable	selectable

¹⁾ Parameter not available for the 3RW55 Failsafe soft starter.

8.15 Failsafe

8.15.1 Operating principle

Observe the safety instructions in chapter Failsafe (Page 22).

Behavior of the failsafe digital input F-DI

The 3RW55 Failsafe soft starter is only switched on by a control command if an ON command is present at the failsafe digital input F-DI. As long as the ON state is present at the failsafe digital input F-DI, the 3RW55 Failsafe soft starter first executes the parameterized starting function and then moves on to the parameterized operating state. The 3RW55 Failsafe soft starter remains in the parameterized operating state until the control command is canceled. The 3RW55 Failsafe soft starter then performs the parameterized shutdown operation. Canceling the ON command at the failsafe digital input F-DI executes the safety function "Safe Torque Off" (STO).

Activation of the "Safe Torque Off" (STO) safety function

The safety function "Safe Torque Off" (STO) is activated by applying an OFF command at the failsafe digital input F-DI. If the 3RW55 Failsafe soft starter receives the request for safe shutdown "Safe Torque Off" (STO) via the failsafe digital input F-DI (change from ON command to OFF command), the current operating state is interrupted immediately and the stopping mode "Coasting down" is used. Note that, in this case, the 3RW55 Failsafe soft starter does not consider any differently parameterized shutdown operation. The 3RW55 Failsafe soft starter signals activation of the safety function "Safe Torque Off" (STO) by an error with the message text "Safety-related shutoff". One exception is the SIL 3 (STO) application with coupling of the control signal at the digital input DI to the enable signal at the failsafe digital input F-DI. In this case, the 3RW55 Failsafe soft starter does not produce an error with message text because the coupling causes the control command at control input DI to be set to OFF automatically.

Timing chart

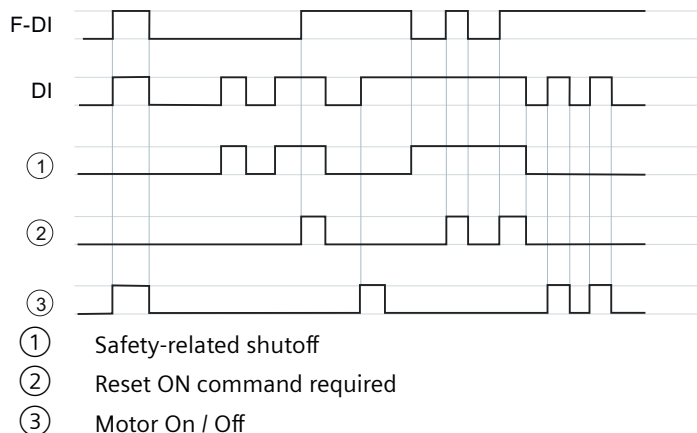

Behavior of the failsafe signaling output F-RQ

In the de-energized condition, the failsafe signaling output F-RQ is opened. As soon as a main supply voltage (operational voltage) is applied, the 3RW55 Failsafe soft starter performs a device test. After a successfully performed test of the switching elements, the failsafe signaling output F-RQ closes. If the motor is shut down and the parameterized stopping mode is ended, the failsafe signaling output F-RQ is still closed. The 3RW55 Failsafe soft starter performs a device test. After a successfully performed device test, another starting operation is possible.

The failsafe signaling output F-RQ signals a device error of the 3RW55 Failsafe soft starter. For SIL 1 applications, this safety signaling output F-RQ can be used to display the device state of the 3RW55 Failsafe soft starter. The safety signaling output F-RQ must be evaluated by a safety relay or safety control in SIL 3 applications to ensure shutdown of the motor in the error state.

The failsafe signaling output F-RQ is only opened in the following cases:

- In the de-energized condition
- When a device error occurs (a group error does not influence the state of the failsafe signaling output F-RQ)
- During the firmware update of the 3RW55 Failsafe soft starter
- During the Self-test (user-test)

8.15.2 Resetting safety-related shutoff

After a safety-related shutoff, an automatic restart cannot be performed. Depending on the STO application used, perform the following procedure to restart the motor.

Requirements

- 3RW55 Failsafe soft starter
- Observe the method of operation (Page 214) and the safety instructions in chapter Failsafe (Page 22).

Procedure for SIL 1 (STO)

1. Reset the signal at the failsafe digital input F-DI by changing from the OFF command to the ON command.
Note that just resetting the EMERGENCY-STOP pushbutton does not initiate a restart (EN 60204-1).
2. Acknowledge the error with the message text "Safety-related shutoff" by canceling the motor ON command.
Note that the error with the message text "Safety-related shutoff" can only be acknowledged with the stop key if a 3RW5 HMI High Feature is used.
The motor can be started again.
3. Set a start command at digital input DI again
The motor starts again.

Procedure for SIL 3 (STO)

1. Reset the signal at the failsafe digital input F-DI by issuing an enable signal by pressing the start key on the safety relay / safety control.
2. Acknowledge the error with the message text "Safety-related shutoff" by canceling the motor ON command.
Note that the error with the message text "Safety-related shutoff" can only be acknowledged with the stop key if a 3RW5 HMI High Feature is used.
The motor can be started again.
3. Set a start command at digital input DI again
The motor starts again.

Procedure for SIL 3 (STO) with coupling of the control signal at the digital input DI to the enable signal at the failsafe digital input F-DI.

Reset the signal at the failsafe digital input F-DI by issuing an enable signal by pressing the start key on the safety relay / safety control.

The motor starts again if a start command is still present at the digital input DI.

8.16 Functions under "Additional parameters"

Operating principle

The 3RW55 and 3RW55 Failsafe soft starters have additional functions and settable parameters that are to be found under "Additional parameters" in the 3RW5 HMI High Feature.

Setting options

- 3RW5 HMI High Feature
Menu: "Parameters > Soft Starter > Additional parameters"
Access protection to the 3RW5 HMI High Feature is not active or has been reset.
- With SIRIUS Soft Starter ES (TIA Portal) via the local interface on the 3RW5 HMI High Feature
Brief overview: Window "Project Navigation" with current project under created Soft Starter > "Parameters" > Window "Work area" > "Soft Starter > Additional parameters"
- With a fieldbus via a 3RW5 communication module:
 - With SIRIUS Soft Starter ES (TIA Portal) Premium / Professional (only via a 3RW5 PROFINET or PROFIBUS communication module)
Brief overview: See SIRIUS Soft Starter ES (TIA Portal) via the local interface on the 3RW5 HMI High Feature
 - Configuration software of the control system (e.g. STEP 7 with corresponding HSP)
 - User program

You can find additional information on the parameters that can be set via the fieldbus in the manual of the respective 3RW5 communication module.

Parameters

Parameters	Description
Operation with CPU / Master	
Response to CPU / Master Stop	<p>This parameter defines how the 3RW55 and 3RW55 Failsafe soft starters behave on failure of the bus connection or CPU stop.</p> <ul style="list-style-type: none"> • Switch substitute value (factory setting) The process image output is automatically changed by the 3RW55 or 3RW55 Failsafe soft starter to the values specified in the following "Substitute value" parameter. • Keep last value The 3RW55 or 3RW55 Failsafe soft starter does not modify the process image output. The current control commands are retained.

8.16 Functions under "Additional parameters"

Parameters	Description
Substitute value ¹⁾	<p>On failure of the bus connection or CPU stop, the 3RW55 and 3RW55 Failsafe soft starters can be controlled by a substitute process image output.</p> <ul style="list-style-type: none"> • Motor CW • Motor CCW • Reset • Emergency start • Creep speed²⁾ • Output 1 • Output 2 • Parameter set 1 • Parameter set 2 • Parameter set 3 • Disable Quick-stop • Output 3²⁾ • Start pump cleaning (only adjustable via user program) • Manual operation local - Input controlled (only adjustable via user program) • Use alternative stopping mode • Motor standstill
Parameters of CPU / master disabled	<p>This parameter defines how the 3RW55 and 3RW55 Failsafe soft starters process the parameter values received from the controller. Setting the parameters only affects the device parameters of the 3RW55 and 3RW55 Failsafe soft starters. Device parameters of the 3RW5 HMI High Feature and of the 3RW5 communication module are always overwritten regardless of how the parameters are set.</p> <ul style="list-style-type: none"> • Deactivate (factory setting) The parameters set on the 3RW55 or 3RW55 Failsafe soft starter are overwritten on bus startup by the values stored in the configuration software of the controller. • Activate The soft starter acknowledges to the controller the correct receipt of all the parameter values sent to it by the controller via cyclic and acyclic communication channels. The 3RW55 or 3RW55 Failsafe soft starter then rejects these values. This prevents the parameters stored in the 3RW55 and 3RW55 Failsafe soft starters from being overwritten. • Activate only for startup parameter The parameterization block only affects the starting parameters upon start-up. The setting is only possible together with a 3RW5 PROFINET or PROFIBUS communication module.

8.16 Functions under "Additional parameters"

Parameters	Description
<p>Response to overload switching element</p>	<p>This parameter determines how the soft starter will behave when the intrinsic device protection has tripped due to an overload.</p> <ul style="list-style-type: none"> • Turn off without restart (factory setting) If a fault limit is exceeded, an error message and an internal trip command are generated. If a lower fault limit is violated, the error message and the internal trip command can be acknowledged with the "Reset" function after a cooling time of 60 seconds. • Turn off with restart If a fault limit is exceeded, an error message and an internal trip command are generated. If a lower fault limit is violated, the error message and internal trip command are automatically acknowledged or canceled after a cooling time of 60 seconds.
<p>Response to preset unequal actual configuration for the following devices:</p> <ul style="list-style-type: none"> • Soft starter • 3RW5 HMI High Feature • Communication module (if there is one) 	<p>A preset unequal actual configuration is present if there is a faulty configuration or if there are differences between the real and configured slots of the module. The parameter has no effect if a higher-level controller transfers a parameter assignment.</p> <ul style="list-style-type: none"> • Ignore (factory setting) In the case of a preset unequal actual configuration the 3RW55 or 3RW55 Failsafe soft starter continues to operate (if necessary) with a restricted function. If necessary, the technology function operates with substitute values to be determined on a product-specific basis. • Warn In the case of a preset unequal actual configuration, no internal trip command is generated. The warning "preset unequal actual configuration" appears. • Turn off In the case of a preset unequal actual configuration, an internal trip command is generated. This internal trip command must be acknowledged with the "Reset" function. If a 3RW5 PROFINET or PROFIBUS communication module is available, then when a module is withdrawn or inserted a corresponding withdrawal / insertion alarm is sent to the higher-level controller.
<p>Bypass operating mode³⁾</p>	<ul style="list-style-type: none"> • Internal bypass (factory setting) • External bypass²⁾ Note that in this operating mode, the motor current can no longer be measured by the soft starter. Functions that are based on this current measured value are deactivated (electronic motor overload protection, diagnostic messages, ...) For a sample circuit, see Chapter "External bypass (Page 336)". Contact Technical Support (Support Request (Page 11)) for operating with an external bypass. • No bypass²⁾ Use the "No bypass" setting for applications with high switching frequency. Please note that the "No bypass" setting is not suitable for applications in continuous duty. Contact Technical Support (Support Request (Page 11)) for operating without a bypass.

8.17 Setting the date and time

Parameters	Description
Permissible main power rotation	<ul style="list-style-type: none"> Any (factory setting) The main power rotation may be "clockwise" or "counter-clockwise". Clockwise The main power rotation must be "CW". Counter-clockw. The main power rotation must be "CCW".
Response to faulty main power	<p>In certain applications, operation of the motor is permitted only in a specified, preset direction of rotation, to avoid damage. The 3RW55 or 3RW55 Failsafe soft starter detects the main power rotation via the measurement process. The required main power rotation is determined when the application is first commissioned. Via the "Response to faulty main power" parameter, you can determine the response of the 3RW55 or 3RW55 Failsafe soft starter to main power rotation deviations.</p> <ul style="list-style-type: none"> Group error only at ON command (factory setting) If the 3RW55 or 3RW55 Failsafe soft starter detects a wrong main power rotation, a fault is generated. Warn If the 3RW55 or 3RW55 Failsafe soft starter detects a wrong main power direction, a warning is generated.
Typical ambient temperature (can only be set via 3RW5 HMI High Feature)	<p>The 3RW55 or 3RW55 Failsafe soft starter is set to the predominant typical ambient temperature actually present in the system. Ensure that the set typical ambient temperature is not exceeded.</p> <ul style="list-style-type: none"> 40 °C 50 °C 60 °C (factory setting)

- 1) In the 3RW5 HMI High Feature, the parameter is only visible if "Switch substitute value" is selected in the parameter "Response to CPU / Master Stop".
- 2) This function is not available for the 3RW55 Failsafe soft starter.
- 3) For 3RW55 soft starter from firmware version V2.0

8.17 Setting the date and time

Operating principle

The 3RW55 and 3RW55 Failsafe soft starters have a capacitor-buffered real-time clock with a power reserve of about 3 days. You can set parameters for the date and time in the 3RW55 and 3RW55 Failsafe soft starters.

If the 3RW5 PROFINET High Feature communication module is used, time synchronization according to the NTP method is available. You will find further information in the manual of the 3RW5 PROFINET communication module.

Setting options

- 3RW5 HMI High Feature
Menu: "Parameter > Soft starter > Date and time"
Access protection to the 3RW5 HMI High Feature is not active or has been reset.
- With SIRIUS Soft Starter ES (TIA Portal) via the local interface on the 3RW5 HMI High Feature
Brief overview: Window "Project Navigation" with current project under created Soft Starter > "Parameters" > Window "Work area" > "Soft Starter > Date and time"
- With a fieldbus via a 3RW5 communication module:
 - With SIRIUS Soft Starter ES (TIA Portal) Premium / Professional (only via a 3RW5 PROFINET or PROFIBUS communication module)
Brief overview: See SIRIUS Soft Starter ES (TIA Portal) via the local interface on the 3RW5 HMI High Feature
 - Configuration software of the control system e.g. STEP 7 with corresponding HSP
 - User program

You can find additional information on the parameters that can be set via the fieldbus in the manual of the respective 3RW5 communication module.

Procedure

1. Select the menu item "Edit time".
2. Set the current time.
3. Select the menu item "Edit date".
4. Set the current date.

Parameters

Parameters	Description
Edit time	Sets the current time
Time format	<ul style="list-style-type: none"> • 12 h (default) • 24 h
Time offset	Difference to UTC time zone: UTC +/- 12 h (in steps of at least 30 minutes)
Display time	The time is shown in the display of the 3RW5 HMI High Feature. <ul style="list-style-type: none"> • Yes • No (factory setting)
Edit date	Sets the current date
Format of date	<ul style="list-style-type: none"> • Day.Month.Year • Day/Month/Year (factory setting) • Year-Month-Day

Result

Date and time are stored in the 3RW55 or 3RW55 Failsafe soft starter. When replacing the 3RW5 HMI High Feature, the date and time are retained in the 3RW55 or 3RW55 Failsafe soft starter.

8.18 Trace

Operating principle

With the trace function (oscilloscope function), the 3RW55 and 3RW55 Failsafe soft starters can be used as a kind of multichannel digital oscilloscope. The trace function enables you to record data, events, measured values, etc. in any operating mode of the motor. The trace data must be read out with the aid of the SIRIUS Soft Starter ES software (TIA Portal) from the 3RW55 or 3RW55 Failsafe soft starter. The trace data is visualized in the form of an oscillogram in the SIRIUS Soft Starter ES (TIA Portal). With a 3RW5 HMI High Feature from firmware version V3.0, you can save trace data on a micro SD card (Page 245).

Requirements

- SIRIUS Soft Starter ES (TIA Portal) Standard / Professional
Brief overview: Window "Project Navigation" with current project under created Soft Starter > "Traces"

Types of trace

- Device trace
The recordings are saved on the 3RW55 or 3RW55 Failsafe soft starter and, when required, can be read out and displayed as a graph using the SIRIUS Soft Starter ES (TIA Portal) software.
- Engineering trace
Recordings are read out cyclically using the SIRIUS Soft Starter ES (TIA Portal) software and displayed as a graph.

Structure of trace data

- Trace configuration: The configuration defines which signals are to be recorded in the 3RW55 or 3RW55 Failsafe soft starter and how (trigger, recording pulse).
- Diagram: The diagram consists of the display options for the recorded data and - if the recording has already taken place - the recorded data itself.

A diagram that contains the recorded data can be stored permanently in the project as a measurement.

Example of trace data

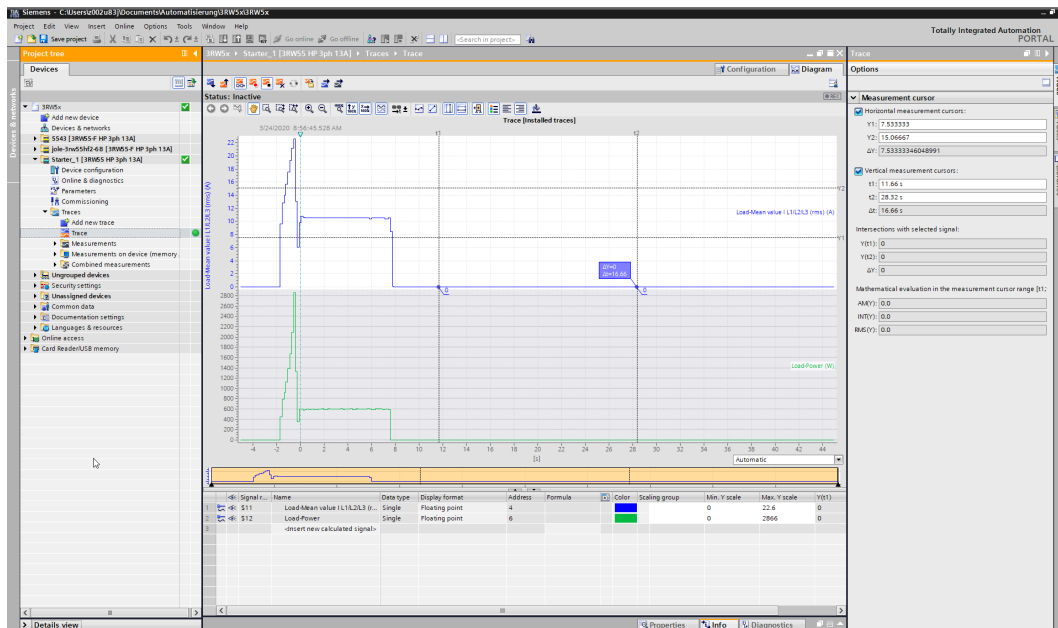

Additional information

Further information on the trace function can be found in the online help for the SIRIUS Soft Starter ES (TIA Portal).

8.19 Test mode

Operating principle

The 3RW55 and 3RW55 Failsafe soft starters must be in test mode for the test mode functions "Test with small load" (Page 224) and "Simulation" (Page 226) In test mode, the "RN" LED flashes green on the 3RW55 or 3RW55 Failsafe soft starter. The 3RW55 and 3RW55 Failsafe soft starters must be in Normal operation mode to enable normal operation.

The parameters "Test mode" and "Normal operation" are not available in the 3RW5 HMI High Feature.

Setting options

⚠ WARNING

**Automatic starting in test operation (test with a small load and simulation)
Can cause death or serious injury.**

The 3RW55 and 3RW55 Failsafe soft starters immediately continue to operate with the values set by the control once test operation has been activated. Outputs are activated when the ON condition is met.

Take appropriate measures to prevent unintentional starting and to ensure a defined start of the system.

- 3RW5 HMI High Feature (from firmware version V2.0)
Access protection to 3RW5 HMI High Feature is not active or has been reset.
Menu: "Control > Test mode"

Note

Activating test mode

If you activate or deactivate "Test with small load" or the "Simulation" on the 3RW5 HMI High Feature, you will automatically also switch to Test mode or Normal operation. For activation and deactivation on the 3RW5 HMI High Feature, the 3RW5 HMI High Feature must have master control.

- With SIRIUS Soft Starter ES (TIA Portal) via the local interface on the 3RW5 HMI High Feature
Brief overview: Window "Project Navigation" with current project under created Soft Starter > "Commissioning" > Window "Work area" > "Soft Starter > Functions > Test mode"
- With a fieldbus via a 3RW5 communication module (only via a 3RW5 PROFINET or PROFIBUS communication module):
 - With SIRIUS Soft Starter ES (TIA Portal) Premium / Professional
Brief overview: See SIRIUS Soft Starter ES (TIA Portal) via the local interface on the 3RW5 HMI High Feature
 - Configuration software of the control system (e.g. STEP 7 with corresponding HSP)
 - User program

8.19.1 Test with small load

Operating principle

The test mode function "Test with small load" is helpful during commissioning and when troubleshooting, as the correct function of the application can be tested before installation in a control cabinet or before the use of a motor provided for the application. The "Test with small load" provides a way of checking the wiring of the control and main circuit with the aid of a small motor (test motor).

In the test mode function "Test with small load", the motor operating states and all functions and messages can be executed and displayed by the 3RW55 or 3RW55 Failsafe soft starter as in normal operation.

If, during an active "Test with small load", the 3RW55 or 3RW55 Failsafe soft starter detects that the main power current is missing, a fault is generated with a shutdown command and the message text "Line voltage for test required". After connecting the 3RW55 or 3RW55 Failsafe soft starter to the main supply this error message can be acknowledged with Reset.

The error monitoring functions that are to be attributed to a missing or inadequate main supply are not active. The test mode function "Test with small load" remains active until the test mode function is deactivated.

The motor and intrinsic device protection functions of the 3RW55 and 3RW55 Failsafe soft starters remain active according to their parameterization and are not influenced by the test mode function "Test with small load".

Requirements

- The 3RW55 or 3RW55 Failsafe soft starter is connected to the main circuit.
- The test mode functions, e.g. "Simulation" or "Self-test (user-test)" are deactivated.
- The test motor is connected to the 3RW55 or 3RW55 Failsafe soft starter.
- Permissible power range of the test motor:
 - < 10% of the rated power of the motor provided for the application
 - ≥ 1 kW
- The test motor is switched off prior to activation of the test mode function "Test with small load".
- The 3RW55 or 3RW55 Failsafe soft starter must be in Test mode (Page 223). In test mode, the "RN" LED flashes green on the 3RW55 or 3RW55 Failsafe soft starter.

Note

Activating test mode

If you activate or deactivate "Test with small load" on the 3RW5 HMI High Feature, you will automatically also switch to Test mode or Normal operation. For activation and deactivation on the 3RW5 HMI High Feature, the 3RW5 HMI High Feature must have master control.

Setting options

⚠ WARNING

**Automatic starting in test operation (test with a small load)
Can cause death or serious injury.**

The 3RW55 and 3RW55 Failsafe soft starters immediately continue to operate with the values set by the control once test operation has been activated. Outputs are activated when the ON condition is met.

Take appropriate measures to prevent unintentional starting and to ensure a defined start of the system.

- 3RW5 HMI High Feature (from firmware version V2.0)
Menu: "Control > Test mode"
Access protection to 3RW5 HMI High Feature is not active or has been reset.
- With SIRIUS Soft Starter ES (TIA Portal) via the local interface on the 3RW5 HMI High Feature
Brief overview: Window "Project Navigation" with current project under created Soft Starter > "Commissioning" > Window "Work area" > "Soft Starter > Functions > Test mode"
- With a fieldbus via a 3RW5 communication module (only via a 3RW5 PROFINET or PROFIBUS communication module):
 - With SIRIUS Soft Starter ES (TIA Portal) Premium / Professional
Brief overview: See SIRIUS Soft Starter ES (TIA Portal) via the local interface on the 3RW5 HMI High Feature
 - Configuration software of the control system (e.g. STEP 7 with corresponding HSP)
 - User program

Parameters

Parameters	Description
Activate test with small load	The 3RW55 or 3RW55 Failsafe soft starter switches to the test mode function "Test with small load".
Deactivate test with small load	The test mode function "Test with small load" is terminated. The 3RW55 or 3RW55 Failsafe soft starter exits the test mode and switches back to the parametrized operating mode.

8.19.2 Simulation

Operating principle

The test mode function "Simulation" is useful for commissioning and troubleshooting because any situations can be tested without great effort, e.g. wiring modifications, connection of external devices or interventions in the PLC.

With the test mode function "Simulation", the 3RW55 soft starter virtually simulates the motor operating states (starting, running, stopping) without main current. The 3RW55 soft

starter tests the wiring, the behavior when the monitoring function responds and the soft starter parameterization of the plant for correct functioning. In simulation of the motor operating states, all functions and messages of the 3RW55 soft starter are executed and displayed as in normal operation. The error monitoring functions that are to be attributed to a missing main supply are not active.

If, during an active "Simulation", the 3RW55 soft starter detects the presence of main current, a fault is generated with a shutdown command and the message text "Line voltage for test not permissible". This safety measure prevents a connected motor from being switched on accidentally. After disconnection of the 3RW55 soft starter from the main supply, this error message can be acknowledged with Reset. The "Simulation" remains active until the test mode function is deactivated.

The motor and intrinsic device protection functions of the 3RW55 soft starter remain active according to their parameterization and are not influenced by the test mode function "Simulation".

Validity

This function is not available for the 3RW55 Failsafe soft starter.

Requirements

- 3RW55 soft starter from firmware version V2.0
- The test mode functions, e.g. "Test with small load" or "Self-test (user-test)" are deactivated.
- The 3RW55 soft starter is disconnected from the main circuit.
- The motor is switched off.
- The 3RW55 soft starter must be in Test mode (Page 223). In test mode, the "RN" LED flashes green on the 3RW55 soft starter.

Note

Activating test mode

If you activate or deactivate the "Simulation" on the 3RW5 HMI High Feature, you will automatically also switch to Test mode or Normal operation. For activation and deactivation on the 3RW5 HMI High Feature, the 3RW5 HMI High Feature must have master control.

Setting options

⚠ WARNING

**Automatic starting in test operation (simulation)
Can cause death or serious injury.**

The 3RW55 and 3RW55 Failsafe soft starters immediately continue to operate with the values set by the control once test operation has been activated. Outputs are activated when the ON condition is met.

Take appropriate measures to prevent unintentional starting and to ensure a defined start of the system.

The execution of the test mode function "Simulation" is possible as follows:

- 3RW5 HMI High Feature (from firmware version V2.0)
Menu "Control > Test mode"
Access protection to 3RW5 HMI High Feature is not active or has been reset.
- With SIRIUS Soft Starter ES (TIA Portal) via the local interface on the 3RW5 HMI High Feature
Brief overview: Window "Project Navigation" with current project under created Soft Starter > "Commissioning" > Window "Work area" > "Soft Starter > Functions > Test mode"
- With a fieldbus via a 3RW5 communication module (only via a 3RW5 PROFINET or PROFIBUS communication module):
 - With SIRIUS Soft Starter ES (TIA Portal) Premium / Professional
Brief overview: See SIRIUS Soft Starter ES (TIA Portal) via the local interface on the 3RW5 HMI High Feature
 - Configuration software of the control system (e.g. STEP 7 with corresponding HSP)
 - User program

Parameters

Parameters	Description
Activate simulation	On activation of the test mode function "Simulation", simulation of the motor operating states is started automatically.
Deactivate simulation	On deactivation of the test mode function "Simulation", simulation of the motor operating states is ended automatically.

8.20 Monitoring

8.20.1 Monitoring the measured values of the 3RW55 soft starter with the 3RW5 HMI High Feature

Operating principle

The measured values are provided by the respective device functions. All measured values are stored in the measured value memory, which is volatile. These values can be read out and evaluated by the 3RW5 HMI High Feature. You can specify up to 5 measured values, which are shown on the operation display (Page 123).

Display on the 3RW5 HMI High Feature

- Menu: "Monitoring > Measured values"

Further display options of the measured values

- With SIRIUS Soft Starter ES (TIA Portal) via the local interface on the 3RW5 HMI High Feature
Brief overview: Window "Project Navigation" with current project under created Soft Starter > "Commissioning" > Window "Work area" > "Soft Starter > Measured values"
- With a fieldbus via a 3RW5 communication module:
 - With SIRIUS Soft Starter ES (TIA Portal) Premium / Professional (only via a 3RW5 PROFINET or PROFIBUS communication module)
Brief overview: See SIRIUS Soft Starter ES (TIA Portal) via the local interface on the 3RW5 HMI High Feature
 - Configuration software of the control system (e.g. STEP 7 with corresponding HSP)
 - User program

Measured values

Measured value		Description
Phase currents (%)	<ul style="list-style-type: none"> • I L1 • I L2 • I L3 • Average • Show bar chart¹⁾ 	<p>The phase currents are shown as a percentage relative to the rated operational current I_e. You can monitor each phase (L1/L2/L3) individually, or the average of all 3 phases.</p> <p>These measured values can be presented graphically as a bar or line chart on the display of the 3RW5 HMI High Feature.¹⁾</p> <p>You will find further information in chapters Design and operator controls of the High Feature 3RW5 HMI (Page 100) and Graphical display of measured values on the 3RW5 HMI High Feature (Page 231).</p>
Phase currents (rms)	<ul style="list-style-type: none"> • I L1 • I L2 • I L3 • Average • I L1/L2/L3 max • Show bar chart¹⁾ 	<p>The phase currents are displayed in amperes. You can monitor each phase (L1/L2/L3) individually, the average of all 3 phases, or the maximum value of each phase.</p> <p>These measured values can be presented graphically as a bar or line chart on the display of the 3RW5 HMI High Feature.¹⁾</p> <p>You will find further information in chapters Design and operator controls of the High Feature 3RW5 HMI (Page 100) and Graphical display of measured values on the 3RW5 HMI High Feature (Page 231).</p>
Asymmetry		The maximum deviation as a percentage of one phase current relative to the average value of all 3 phase currents.
Motor voltage	<ul style="list-style-type: none"> • U L1-L2 • U L2-L3 • U L3-L1 	<p>The motor voltage is shown in Volts. You can monitor the motor voltage of each phase.</p> <p>These measured values can be presented graphically as a line chart on the display of the 3RW5 HMI High Feature.¹⁾</p> <p>You will find further information in chapters Design and operator controls of the High Feature 3RW5 HMI (Page 100) and Graphical display of measured values on the 3RW5 HMI High Feature (Page 231).</p>
Power	Active power	<p>Indicates the current active power in kW.</p> <p>This measured value can be presented graphically as a line chart on the display of the 3RW5 HMI High Feature.¹⁾</p> <p>You will find further information in chapters Design and operator controls of the High Feature 3RW5 HMI (Page 100) and Graphical display of measured values on the 3RW5 HMI High Feature (Page 231).</p>
	Power factor L1...3	Indicates the current power factor.
Line frequency		Indicates the current line frequency in Hz.
Output frequency		This value is displayed only if the starting and stopping output frequencies differ from the line frequency.
Motor temperature rise		Current value of motor temperature rise in %. This measured value is calculated internally by the 3RW55 or 3RW55 Failsafe soft starter and indicates the relative temperature rise of the motor.
Remaining time for motor overload protection		The remaining time for motor overload protection provides a dynamic prediction of the time in seconds remaining until the tripping of the motor overload protection, depending on the momentary motor current.
Remaining motor cooling time		The remaining recovery time in seconds after protective tripping of the motor until the 3RW55 or 3RW55 Failsafe soft starter is ready to operate again.

Measured value	Description
Remaining switching element cooling time	The remaining cooling time of the switching element depends on the thermal capacity of the power unit and the ambient conditions (temperature, air circulation, installation location, etc.). The remaining switching element cooling time is stated in seconds.
Switching element heating	The currently calculated switching element heating is continuously compared with the previously saved switching element heating and indicated in %.
Remaining switching frequency monit. time	The remaining time in seconds following a switching operation until the motor can be switched on again. You will find more information in chapter Switching frequency monitoring (Page 180).

¹⁾ For 3RW5 HMI High Feature from firmware version V3.0

8.20.2 Graphical display of measured values on the 3RW5 HMI High Feature

Requirements

- 3RW5 HMI High Feature from firmware version V3.0

Operating principle

The 3RW55 and 3RW55 Failsafe soft starters support graphical display of measured values. These measured values can be presented as bar or line charts on the display of the 3RW5 HMI High Feature.

Procedure for displaying bar charts

The following measured values can be shown in the bar chart:

- Phase current L1 (%) and (rms)
 - Phase current L2 (%) and (rms)
 - Phase current L3 (%) and (rms)
 - Phase current average (%) and (rms)
1. Select the menu item "Monitoring > Measured values > Phase currents (%) / Phase currents (rms) > Show bar chart".
Depending on the menu item selected, the current values of the 3 phase currents (%) or phase currents (rms) and the average value are displayed graphically in a bar chart.
 2. Use the left and right navigations keys of the 3RW5 HMI High Feature to switch the view between Phase currents (%) and Phase currents (rms).
 3. Press the ESC key to exit the bar chart view.

The example chart shows the current 3 phase currents (L1/L2/L3) and the associated average value as a percentage. The scaling of the x-axis is 200%.



Procedure for displaying line charts

The following measured values can be shown in the line chart:

- Phase current L1 (%) and (rms)
- Phase current L2 (%) and (rms)
- Phase current L3 (%) and (rms)
- Phase current average (%) and (rms)
- Line-to-line voltages U L1-L2 [V]
- Line-to-line voltages U L2-L3 [V]
- Line-to-line voltages U L3-L1 [V]
- Active power

Operation display

1. Select the measured value to be displayed in the operation display and press the right navigation key of the 3RW5 HMI High Feature.
The selected measured value is shown graphically in a line chart.
2. Use the left and right navigation keys of the 3RW5 HMI High Feature to switch the view between measured values (only possible within current or voltage measured values).
3. Press the ESC key to exit the line chart view.

"Monitoring" menu

1. Select the menu item "Monitoring > Measured values".
2. Select the measured value to be displayed and press the right navigation key of the 3RW5 HMI High Feature.
The selected measured value is shown graphically in a line chart.
3. Use the left and right navigation keys of the 3RW5 HMI High Feature to switch the view between measured values (only possible within current or voltage measured values).
4. Press the ESC key to exit the line chart view.

The sample chart shows the actual phase current I L1 as a percentage. The scaling of the y-axis is 200%.

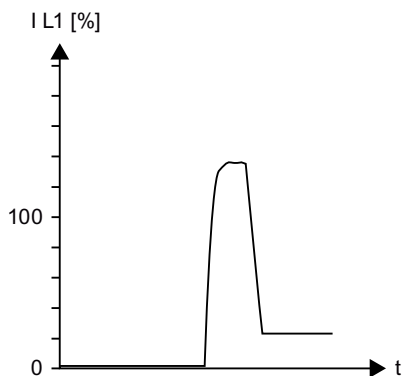

If the measured value exceeds the limit of the scaling (200% in the example), the line extends parallel with the x-axis and is displayed red in that area.

8.20.3 Monitoring the process image of the 3RW55 soft starter with the 3RW5 HMI High Feature

Operating principle

The process image input (PII) contains current information about the soft starter and process state. The process image output (PIQ) contains the current control commands to the 3RW55 or 3RW55 Failsafe soft starter. The control command states of the control source, which has control priority according to the operating mode controller, are entered in the data memory of the process image outputs. Note the overview of the process images in chapter Process data and process images (Page 198).

Display on the HMI High Feature

- Menu: "Monitoring > Process image"

Display of the process images on the 3RW5 HMI High Feature

In the process image input (PII) and process image output (PIQ), you can see which bits of the process image are active or inactive:

Check box	Status	Bit
<input type="checkbox"/>	inactive	0
<input checked="" type="checkbox"/>	active	1

Further display options

- With SIRIUS Soft Starter ES (TIA Portal) via the local interface on the 3RW5 HMI High Feature
Brief overview: Window "Task Card" > Tab "Online Tools" > "SIRIUS Control Panel"
- With a fieldbus via a 3RW5 communication module:
 - With SIRIUS Soft Starter ES (TIA Portal) Premium / Professional (only via a 3RW5 PROFINET or PROFIBUS communication module)
Brief overview: See SIRIUS Soft Starter ES (TIA Portal) via the local interface on the 3RW5 HMI High Feature
 - Configuration software of the control system (e.g. STEP 7 with corresponding HSP)
 - User program

Additional information

You will find further information on transferring the process images via a fieldbus in the device manual for the respective 3RW5 communication module.

8.21 Control via 3RW5 HMI High Feature

Operating principle

You can control the 3RW55 and 3RW55 Failsafe soft starters via the 3RW5 HMI High Feature with the aid of various control commands. You can facilitate quick access by assigning various control commands to the Start key and Function selection key F1-F9. You will find further information in chapters Configuring the start key of the 3RW5 HMI High Feature (Page 121) and Configuring the Function selection key F1-F9 of the 3RW5 HMI High Feature (Page 119).

Control via 3RW5 HMI High Feature

- Menu: "Control"

Further control options

- With SIRIUS Soft Starter ES (TIA Portal) via the local interface on the 3RW5 HMI High Feature
Brief overview: Window "Task Card" > Tab "Online Tools" > "SIRIUS Control Panel"
- With a fieldbus via a 3RW5 communication module:
 - With SIRIUS Soft Starter ES (TIA Portal) Premium / Professional (only via a 3RW5 PROFINET or PROFIBUS communication module)
Brief overview: See SIRIUS Soft Starter ES (TIA Portal) via the local interface on the 3RW5 HMI High Feature
 - Configuration software of the control system (e.g. STEP 7 with corresponding HSP)
 - User program

Control commands

Control command		Description
Select parameter set	Parameter set 1 (factory setting)	Select one of the 3 parameter sets. One parameter set is deactivated when another parameter set is activated. One parameter set must be active at all times.
	Parameter set 2	
	Parameter set 3	
Local/Remote		Changes the location of control.
Control motor	Motor CW	Motor rotates clockwise
	Motor CCW	Motor rotates counter-clockwise. The control command can also be executed in reversing mode (with ext. contactor).
	Stop motor	The activation command to the motor is canceled
	Creep speed ¹⁾	Make sure that the control command "Motor CW" or "Motor CCW" is applied with the control command "Creep speed". <ul style="list-style-type: none"> • Activate • Deactivate (factory setting) You will find more information in chapter Creep speed (Page 174).
	Alternative stopping mode	Activate alternative stopping in order to set up an additional stop in parameter set 1. <ul style="list-style-type: none"> • Activate • Deactivate You will find more information in chapter Alternative stopping (Page 165).
	Pump cleaning start	This control command is only visible if the pump cleaning function has been parameterized. You will find more information in chapter Pump cleaning function (Page 184).
Reset		Execute a RESET. You will find more information in chapter Reset (Page 175).
Disable Quick-stop		Motor does not stop despite pending ON command of Quick-stop. You will find more information in chapter Quick-stop (Page 176).
Emergency mode	Emergency start	The system can continue to be operated in the case of system faults with the "emergency start" function. <ul style="list-style-type: none"> • Enable • Disable You will find more information in chapter Emergency start (Page 191).
	Emergency run ^{1), 2)}	With the "Emergency run" function, the 3RW55 soft starter can continue to run with restricted functionality after failure of a power semiconductor. <ul style="list-style-type: none"> • Enable • Disable You will find more information in chapter Emergency run (Page 193).

Control command		Description
Test mode	Test with small load	<p>The test mode function "Test with small load" provides a way of checking the wiring of the control and main circuit with the aid of a small motor (test motor).</p> <ul style="list-style-type: none"> • Activate • Deactivate <p>You will find more information in chapter Test with small load (Page 224).</p>
	Simulation ^{1), 3)}	<p>With the test mode function "Simulation", the 3RW55 soft starter virtually simulates the motor operating states (starting, running, stopping) without main current.</p> <ul style="list-style-type: none"> • Activate • Deactivate <p>You will find more information in chapter Simulation (Page 226).</p>
PIQ-DQ Bit 1.0 (output 1)		Activates or deactivates the control command concerned.
PIQ-DQ Bit 1.1 (output 2)		Requirement: The output action "Control source PIQ-DQ x.y Output n" is assigned to a digital output.
PIQ-DQ Bit 2.0 ¹⁾ (output 3)		<ul style="list-style-type: none"> • 3RW55 soft starter: You can assign the control commands "Output 1", "Output 2" and "Output 3" to the digital outputs 1, 2 and 4 of the 3RW55 soft starter in any order via the digital output actions. • 3RW55 Failsafe soft starter: You can assign the control commands "Output 1" and "Output 2" to the digital outputs 1 and 2 of the 3RW55 Failsafe soft starter in any order via the digital output actions. <p>You will find more information in chapter Digital outputs (Page 200).</p>

¹⁾ Function is not available for the 3RW55 Failsafe soft starter.

²⁾ For 3RW55 soft starter from firmware version V2.1

³⁾ For 3RW55 soft starter from firmware version V2.0

8.22 Overview

Operating principle

The "Overview" menu displays the connected components and their device-related information (I&M data).

Note

Device-related information

Note that it is only possible to edit the displayed device name of the 3RW55 or 3RW55 Failsafe soft starter via the 3RW5 HMI High Feature.

Display on the 3RW5 HMI High Feature

- Menu: "Overview"

Additional display options of the device-related information (I&M data)

- With SIRIUS Soft Starter ES (TIA Portal) via the local interface on the 3RW5 HMI High Feature
Brief overview: Window "Project Navigation" with current project under created Soft Starter > "Online & Diagnostics" > Window "Work area" > "Soft Starter / 3RW5 communication module used / HMI > Diagnosis > General"
- With a fieldbus via a 3RW5 communication module:
 - With SIRIUS Soft Starter ES (TIA Portal) Premium / Professional (only via a 3RW5 PROFINET or PROFIBUS communication module)
Brief overview: See SIRIUS Soft Starter ES (TIA Portal) via the local interface on the 3RW5 HMI High Feature
 - Configuration software of the control system (e.g. STEP 7 with corresponding HSP)
 - User program

Note

I&M data

I&M0 data is assigned for all of the devices (3RW5 soft starter, 3RW5 HMI High Feature, and 3RW5 communication module) and can be read out. Only the proxy for the "Station" (slot 0) has adjustable and readable I&M1, I&M2 and I&M3 data. The "Station" comprises the following devices:

- 3RW5 communication module (slot 1)
 - 3RW5 soft starter (slot 2)
 - 3RW5 HMI High Feature (slot 3)
-

Parameter

Parameter		Description
Soft starter	Module	<ul style="list-style-type: none"> • Article number¹⁾ • Hardware¹⁾ • Firmware¹⁾
	Module information	<ul style="list-style-type: none"> • Tag function²⁾
		<ul style="list-style-type: none"> • Tag location²⁾
		<ul style="list-style-type: none"> • Installation date³⁾ • Additional information⁴⁾ Assign a device name to the 3RW5 soft starter via SIRIUS Soft Starter ES or with the 3RW5 HMI High Feature. The device name appears in the top line of the display of the 3RW5 HMI High Feature. If you do not assign any name to the 3RW5 soft starter, the 3RW5 soft starter retains its short designation. If the set device name is too long, only the first part of the device name is displayed.
Manufacturer information	<ul style="list-style-type: none"> • Manufacturer¹⁾ • Serial number¹⁾ 	
HMI	Module	<ul style="list-style-type: none"> • Article number¹⁾ • Hardware¹⁾ • Firmware¹⁾
	Manufacturer information	<ul style="list-style-type: none"> • Manufacturer¹⁾ • Serial number¹⁾
Communication module (if existing)	Module	<ul style="list-style-type: none"> • Article number¹⁾ • Hardware¹⁾ • Firmware¹⁾
	Manufacturer information	<ul style="list-style-type: none"> • Manufacturer¹⁾ • Serial number¹⁾

¹⁾ Part of the I&M0 data

²⁾ Part of the I&M1 data

³⁾ Part of the I&M2 data

⁴⁾ Part of the I&M3 data

8.23 Local access protection and user account administration

8.23.1 General advice on using PINs

The 3RW55 and 3RW55 Failsafe soft starters have 2 functions with a PIN each for protecting against unauthorized access:

- Local access protection (Page 239)
- User account administration (Page 242) (user login and log off (Page 244))

You have the option of combining both versions.

Pins for local access protection and user account administration

Note that each function uses a separate PIN:

- **HMI PIN** for local access protection
- **HMI User PIN** for user accounts

Combination of local access protection and user account administration

When using local access protection and user account administration, note the sequence of PIN entry on the 3RW5 HMI High Feature. Enter the HMI PIN first and then the HMI User PIN in order to unlock locked menus.

If the HMI PIN and the HMI User PIN are identical, there is no need to enter the HMI User PIN on the 3RW5 HMI High Feature.

8.23.2 Local access protection (PIN)

Operating principle

With the PIN, you can protect the 3RW5 HMI High Feature from unauthorized access. The menus of the 3RW5 HMI High Feature can still be viewed with local access protection activated. It is not possible to issue a control command or to set a parameter. If you issue a control command or change a parameter when local access protection is enabled, you will automatically receive an entry prompt for the current PIN beforehand.

The PIN remains even after the power supply has been interrupted. You can reset the local access protection to the factory setting with the master RESET key on the rear of the 3RW5 HMI High Feature (Page 282). Protect the master RESET key from unauthorized access.

Setting on the 3RW5 HMI High Feature

- Menu: "Security > Local access protection"

Parameter

Parameter		Description
Local access protection	Define PIN ¹⁾	PIN is set up and active (Page 240). In the factory setting, no PIN is set up and the local access protection is not active.
	Change PIN ²⁾	Existing PIN is changed (Page 241).
	Delete PIN ²⁾	PIN is deactivated and deleted (Page 241).
	Auto log off time ²⁾	If you do not regularly press a key on the 3RW5 HMI High Feature, the current session will be terminated after the auto logoff time has elapsed. <ul style="list-style-type: none"> • Factory setting: 0 min = deactivated • Setting range: 0 ... 60 min
	Log on ³⁾	Remove the local access protection by logging on with your 4-digit PIN.
	Log off ⁴⁾	Log out of your current session. The local access protection is activated again. Alternatively, the session will be terminated after the auto logoff time.

- ¹⁾ Menu item is displayed if no PIN has been defined.
- ²⁾ Menu item is displayed if a PIN has been defined.
- ³⁾ Menu item is displayed after logging off with an active PIN.
- ⁴⁾ Menu item is displayed after logging on with an active PIN.

8.23.2.1 Define PIN

Requirements

- 3RW5 HMI High Feature
Menu: "Security > Local access protection"
- No PIN is defined (factory setting).

Procedure

1. Select the menu item "Define PIN".
2. Using the navigation keys, set a 4-digit PIN and confirm your entry with the OK key.
3. The user information "HMI PIN defined" appears on the display of the 3RW5 HMI High Feature. Confirm by pressing the OK key.
The 3RW5 HMI High Feature then returns to the "Local access protection" menu.

Result

You have defined the PIN and the set PIN is active.

8.23.2.2 Change PIN

Requirements

- 3RW5 HMI High Feature
Menu: "Security > Local access protection"
- A PIN is defined.

Procedure

1. Select the menu item "Change PIN".
2. Log on using the current 4-digit PIN and confirm your entry with the OK key.
If the entry is correct, the user information "Log on was successful" appears on the display of the 3RW5 HMI High Feature. Confirm by pressing the OK key.
3. Using the navigation keys, set a 4-digit PIN and confirm your entry with the OK key.
The user information "HMI PIN changed" appears on the display of the 3RW5 HMI High Feature. Confirm by pressing the OK key. The 3RW5 HMI High Feature then returns to the "Local access protection" menu.
4. Select the menu item "Log on".
5. Log on using the current 4-digit PIN and confirm your entry with the OK key.
If the entry is correct, the user information "Log on was successful" appears on the display of the 3RW5 HMI High Feature. Confirm by pressing the OK key.

Result

You have changed the PIN and the changed PIN is active.

8.23.2.3 Delete PIN

Requirements

- 3RW5 HMI High Feature
Menu: "Security > Local access protection"
- A PIN is defined.

Procedure

1. Select the menu item "Delete PIN".
2. Log on using the current 4-digit PIN and confirm your entry with the OK key.
If the entry is correct, the user information "HMI PIN deleted" appears on the display of the 3RW5 HMI High Feature. Confirm by pressing the OK key. The 3RW5 HMI High Feature then returns to the "Local access protection" menu.

Resetting the PIN via the factory setting

You can reset the local access protection to the factory setting with the master RESET key on the rear of the 3RW5 HMI High Feature (Page 282).

Result

You have deactivated and deleted the current PIN.

8.23.3 Setting up user account management

Operating principle

In combination with the SIRIUS Soft Starter ES software (TIA Portal), the 3RW55 and 3RW55 Failsafe soft starters support the function of user administration.

Before you are able to log in to the 3RW5 HMI High Feature, the user administrator must first set up a user account with HMI User PIN using the SIRIUS Soft Starter ES software (TIA Portal). The user account is transferred to the 3RW55 or 3RW55 Failsafe soft starter using the local interface, 3RW5 communication module or a micro SD card (only with the function "Device change" (Page 283))

Note

Loss of control priority when user administration is activated

Note that activation of the user administration disconnects the control source from the 3RW55 or 3RW55 Failsafe soft starter and therefore results in loss of master control.

Log onto the 3RW5 HMI High Feature via the "User login" with the HMI User PIN to regain master control. You will find further information on the control priority in chapter Operating modes and master control function (Page 34).

Log onto 3RW5 HMI High Feature via the "User login" with your HMI User PIN. The user administration compares the user account data stored in the 3RW55 or 3RW55 Failsafe soft starter with the HMI User PIN entered by the user. If the data matches, you are granted access with the access rights stored in the user account data until the user monitoring time has elapsed and you are logged off or you log off by means of the "User log off" function. The access rights are contained in the user account data indirectly as user roles.

More information about setting up a user account can be found in the online help for SIRIUS Soft Starter ES (TIA Portal). You can find further information on logging on and off with the HMI User PIN in chapter User login and logout (Page 244).

Requirements

- User account has been set up in SIRIUS Soft Starter ES (TIA Portal).
- User account has been transferred with SIRIUS Soft Starter ES (TIA Portal) via one of the following paths to the 3RW55 or 3RW55 Failsafe soft starter:
 - Local interface
 - Fieldbus via a 3RW5 PROFINET or PROFIBUS communication module
 - Micro SD card (only with the function "Device change" (Page 283))

User roles and user rights

- **User administrator:** Creating, editing or deleting all user accounts.
- **Diagnostics personnel:** Access rights in order to display diagnostic data (without login).
- **Operating personnel:** Functional operation of the 3RW55 or 3RW55 Failsafe soft starter.
- **Maintenance personnel:** Maintenance access (control, parameterize, test) to the device.

	Diagnosis	Control	Parameterizing	FW update	Administration of user accounts
User administrator	-	-	-	-	x
Diagnostics personnel	X	-	-	-	-
Operating personnel	X	X	-	-	-
Maintenance personnel	X	X	X	X	-

When user administration is active, without the HMI user PIN you only have access to the menus "Monitoring", "Diagnosis", "Overview" and "Security".

Parameters of the user accounts

You can log onto the 3RW55 or 3RW55 Failsafe soft starter with the user name and password (via SIRIUS Soft Starter ES (TIA Portal)) or with the 4-digit HMI User PIN (via 3RW5 HMI High Feature).

User name

- 1 ... 32 characters
- Numerals, uppercase and lowercase letters, and all special characters are possible

User password

- 4 ... 32 characters
- Numerals, uppercase and lowercase letters, and special characters ?!+%\$

Note

A secure password is only valid for a single user account, is more than 8 characters long, and contains uppercase and lowercase letters, special characters and numerals. Do not use any common numeric sequences from the computer keyboard or words from the dictionary. Change your password at regular intervals.

HMI User PIN

- 4-digit HMI User PIN
- Digits 0 ... 9
- A login with PIN is only possible via the 3RW5 HMI High Feature

Auto log off time

You will be automatically logged off on expiry of the programmable auto log off time (Page 239).

8.23.4 User login and logout

Operating principle

You can protect the 3RW55 and 3RW55 Failsafe soft starters against unauthorized access by issuing PIN-protected user accounts.

You will find more information in chapter Setting up user account management (Page 242).

Requirements

- User account has been set up in SIRIUS Soft Starter ES (TIA Portal).
- User account has been transferred with SIRIUS Soft Starter ES (TIA Portal) via one of the following paths to the 3RW55 or 3RW55 Failsafe soft starter:
 - Local interface
 - Fieldbus via a 3RW5 PROFINET or PROFIBUS communication module
 - Micro SD card (only with the function "Device change" (Page 283))
- 3RW5 HMI High Feature
Menu: "Security"

Procedure for User login

1. Select the "User login" menu in order to log in with your user account.
2. Enter the 4-digit HMI User PIN.
After correctly entering the HMI User PIN you are logged in with your user account.

Procedure for User log off

1. Select the "User log off" menu in order to log out with your user account.
Access protection is activated again.

Result

With the HMI User PIN you can protect the 3RW55 or 3RW55 Failsafe soft starter from unauthorized access. The "Monitoring", "Diagnosis", and "Overview" menus can still be viewed.

The HMI User PIN is retained even after the power supply has been interrupted.

8.24 Micro SD card

Requirements

- 3RW5 HMI High Feature
Menu: "Micro SD card"
The "Micro SD Card" menu appears after you have inserted a micro SD card into the 3RW5 HMI High Feature.
- Access protection to the 3RW5 HMI High Feature is not active or has been reset.
- Inserted micro SD card, e.g. micro SDHC Class 10
 - File format: FAT32
 - Capacity: max. 32 GB

Note

Interruption of the connection by an unformatted micro SD card

When an unformatted micro SD card is inserted, the connection between 3RW5 HMI High Feature and the soft starter will be briefly interrupted. If the interruption lasts longer than 5 s, the error message "Preset unequal actual configuration" is output. As soon as the connection is up and running again, the error message is reset automatically.

Operating principle

Together with a micro SD card, the 3RW5 HMI High Feature can perform firmware updates, exchange configuration files and service data, and store logbooks.

Parameters

Action	Description
Load parameter settings to soft starter	<p>The parameterization of the 3RW55 or 3RW55 Failsafe soft starter and of the 3RW5 HMI High Feature are transferred from the micro SD card to the 3RW55 or 3RW55 Failsafe soft starter. The following data is transferred:</p> <ul style="list-style-type: none"> • Device parameters of the 3RW55 and 3RW55 Failsafe soft starters • Device parameters of the 3RW5 HMI High Feature • User administration / passwords <p>Applications: Parameterizing the 3RW55 or 3RW55 Failsafe soft starter in series / identically (Page 125)</p>
Save parameter settings to micro SD card	<p>The parameterization of the 3RW55 or 3RW55 Failsafe soft starter, of the 3RW5 HMI High Feature and of the communication are transferred to the micro SD card. The data is saved in an automatically generated folder (e.g. "1P3RW5 xxx-xxxx"). The following data is transferred:</p> <ul style="list-style-type: none"> • I&M 1 data (Page 236) • I&M 3 data (Page 236) • Device parameters of the 3RW55 and 3RW55 Failsafe soft starters • Device parameters of the 3RW5 HMI High Feature • User administration / passwords • Communication parameters <p>Note the information in chapter Firmware update (Page 24). Applications: Parameterizing the 3RW55 or 3RW55 Failsafe soft starter in series / identically (Page 125) "Device change" function (Page 283)</p>
Device change	<p>When a device is replaced, the parameterization of the 3RW55 or 3RW55 Failsafe soft starter, of the 3RW5 HMI High Feature and of the communication can be transferred to the new device. The following data is transferred:</p> <ul style="list-style-type: none"> • I&M 1 data (Page 236) • I&M 3 data (Page 236) • Device parameters of the 3RW55 and 3RW55 Failsafe soft starters • Device parameters of the 3RW5 HMI High Feature • User administration / passwords • Communication parameters <p>Note the information in chapter Firmware update (Page 24). Application: "Device change" function (Page 283)</p>
Save trace data to micro SD card ¹⁾	<p>Via the 3RW5 HMI High Feature, trace data (Page 222) of the 3RW55 or 3RW55 Failsafe soft starter can be saved to the micro SD card and read out via SIRIUS Soft Starter ES (TIA Portal).</p>
Save logbooks to micro SD card	<p>The logbooks are backed up on the micro SD card. You will find more information in chapter Logbooks (Page 268).</p>

Action		Description
Save service data to micro SD card ^{2), 3)}		The 3RW55 and 3RW55 Failsafe soft starters record service data during starting and stopping. If problems occur in the system in conjunction with the 3RW55 or 3RW55 Failsafe soft starter, you can save the service data on the micro SD card and have it evaluated by the service engineers. You will find more information in chapter Save service data to micro SD card (Page 269).
FW update	<ul style="list-style-type: none"> • Soft starter • Communications module • HMI 	The firmware update is carried out if a valid firmware file is stored on the micro SD card. The 3RW5 HMI High Feature automatically detects which firmware file the micro SD card contains You can find more information on the firmware update in chapter Performing firmware update with micro SD card (3RW5 HMI High Feature) (Page 279).
Download language ¹⁾		You can load additional languages onto the 3RW5 HMI High Feature via the micro SD card. You will find more information in chapter Reloading a language for the High Feature 3RW5 HMI (Page 247).
Memory space	<ul style="list-style-type: none"> • Complete memory • Free memory • Used memory 	The memory capacity is displayed.

¹⁾ For 3RW5 HMI High Feature from firmware version V3.0

²⁾ For 3RW5 HMI High Feature from firmware version V2.0

³⁾ For 3RW55 soft starters from firmware version V2.0, for 3RW55 Failsafe soft starters from firmware version V1.0

8.25 Reloading a language for the High Feature 3RW5 HMI

Requirements

- 3RW5 HMI High Feature from firmware version V3.0
Menu: "Micro SD card"
- Micro SD card (Page 245) with valid language file in the 3RW5 HMI High Feature
The first two digits of the version of the language file must match the first two digits of the firmware version (Vx.y) of the 3RW5 HMI High Feature.
You will find the current language files on the Internet (<https://support.industry.siemens.com/cs/ww/en/view/109772736>).
- The valid language file is located in the root directory (topmost level).
- Access protection to 3RW5 HMI High Feature is not active or has been reset.

Operating principle

The 3RW5 HMI High Feature supports the subsequent loading of an additional language. The additional language is transferred from the micro SD card to the 3RW5 HMI High Feature and can then be selected. Loading an additional language overwrites or deletes an already loaded additional language. If the additional language is active when the language update is performed, it will be retained until another language is selected. It is only possible to return to this additional language if this language is updated. The following languages contained in the factory setting of the 3RW5 HMI High Feature are not provided for downloading and are always part of the firmware update for the 3RW5 HMI High Feature:

- English (factory setting)
- German
- French
- Spanish
- Italian
- Portuguese
- Chinese

Procedure

1. Choose the menu item "Download language" and confirm with OK.
2. Select the required language file on the micro SD card and confirm with OK.

Result

You have loaded an additional language onto the 3RW5 HMI High Feature and can set it with the selection "Additional language" (Page 123).

Messages and diagnostics

9.1 Diagnostics options

The 3RW55 and 3RW55 Failsafe soft starters provide you with the following diagnostic options:

- LEDs on the 3RW55 or 3RW55 Failsafe soft starter
 - 3RW5 HMI High Feature
 - SIRIUS Soft Starter ES (TIA Portal) (accessories) via local interface on the 3RW5 HMI High Feature
- Brief overview: Window "Project Navigation" with current project under created Soft Starter > "Commissioning" > Window "Work area" > "Soft Starter / HMI > Diagnosis"

Further diagnostics options

You will find further diagnostics options via the fieldbus in the manual for the respective 3RW5 communication module.

9.2 LED display and displays on the HMI High Feature

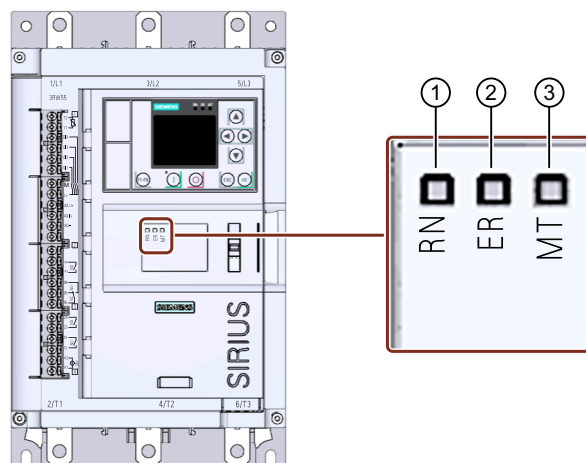

9.2.1 Overview of the device LEDs on the 3RW55 and 3RW55 Failsafe soft starters



- | | | |
|---|-----------------------|--|
| ① | RUN (green) | Indicates whether the 3RW55 or 3RW55 Failsafe soft starter is ready for operation. |
| ② | ERROR (red) | Indicates whether there is an error. |
| ③ | MAINTAINANCE (yellow) | Indicates whether a message is present. |

9.2.2 Status and error displays



LED "RN" - RUN

Status	Meaning
 Lights up green	The 3RW55 or 3RW55 Failsafe soft starter is ready for operation.
 Flashes green	The 3RW55 or 3RW55 Failsafe soft starter is not ready for operation, e.g. due to: <ul style="list-style-type: none"> • System startup • 3RW55 or 3RW55 Failsafe soft starter is reset to factory setting. • Self-test (user-test) active • Firmware update • Test mode active

LED "ER" - ERROR





Status	Meaning
<input type="checkbox"/> Off	No errors are present.
 Flashes red	There is at least one error.

LED "MT" - MAINTENANCE / WARNING

Status	Meaning
<input type="checkbox"/> Off	No warning is active.
 Lights up yellow	At least one warning exists. The cause has not been eliminated.
 Flashes yellow	The 3RW55 or 3RW55 Failsafe soft starter is in energy-saving mode ¹⁾ . You can find further information about the energy-saving mode in the manual for the 3RW5 PROFINET communication module.

¹⁾ 3RW55 soft starter from firmware version V2.1 or 3RW55 Failsafe soft starter from firmware version V1.0

LED combinations

Status			Meaning
RN (RUN)	ER (ERROR)	MT (MAINT)	
 Flashes green	<input type="checkbox"/> Off	 Flashes yellow	<ul style="list-style-type: none"> The 3RW55 or 3RW55 Failsafe soft starter waits for the parameters relevant to ATEX/IECEX/UKEX to be confirmed with the OK key.
 Flashes green	 Flashes red	 Flashes yellow	<ul style="list-style-type: none"> The 3RW55 or 3RW55 Failsafe soft starter is not ready for operation. Device error detected.

9.2.3 Overview of LEDs on High Feature 3RW5 HMI

Device LEDs (RN, ER, MT)



The display of the device LEDs of the 3RW5 HMI High Feature (Page 100) shows the status summary for the following devices:

- 3RW55 or 3RW55 Failsafe soft starter
- 3RW5 communication module (if there is one)
- 3RW5 HMI High Feature

Please note that the display of the device LEDs of the 3RW5 HMI High Feature does not have to correlate with the display of the device LEDs of the 3RW55 or 3RW55 Failsafe soft starter.

Status LED

The display on the status LED of the 3RW5 HMI High Feature (Page 100) indicates the state of the 3RW55 or 3RW55 Failsafe soft starter and the operating state of the motor.

Status LED	Status of the 3RW55 or 3RW55 Failsafe soft starter	Motor operating state
 Lights up green	Operation	The ramp-up time comes to an end and the motor is running.
 Flashes green	Starting or stopping time active	Motor is ramping up or ramping down.

Additional information

You will find further information on messages of the 3RW55 and 3RW55 Failsafe soft starters in chapter Status and error displays (Page 250).

You will find further information on the messages of the 3RW5 communication module in the manual for the 3RW5 communication module in question.

9.2.4 Displays on the HMI High Feature

Symbol	Meaning
	<ul style="list-style-type: none"> The motor is not rotating. Motor start is possible. The HMI High Feature has control priority (manual local)
	<ul style="list-style-type: none"> The motor is not rotating. Motor start is possible. The HMI High Feature does not have control priority.
	<ul style="list-style-type: none"> The motor is rotating counter-clockwise. The HMI High Feature has control priority (manual local).
	<ul style="list-style-type: none"> The motor is rotating counter-clockwise. The HMI High Feature does not have control priority.
	<ul style="list-style-type: none"> The motor is rotating clockwise. The HMI High Feature has control priority (manual local).
	<ul style="list-style-type: none"> The motor is rotating clockwise. The HMI High Feature does not have control priority.
	<ul style="list-style-type: none"> The motor is rotating counter-clockwise at creep speed. The HMI High Feature has control priority (manual local).
	<ul style="list-style-type: none"> The motor is rotating counter-clockwise at creep speed. The HMI High Feature does not have control priority.
	<ul style="list-style-type: none"> The motor is rotating clockwise at creep speed. The HMI High Feature has control priority (manual local).
	<ul style="list-style-type: none"> The motor is rotating clockwise at creep speed. The HMI High Feature does not have control priority.
	<ul style="list-style-type: none"> Parameter set 1 is active.
	<ul style="list-style-type: none"> Parameter set 2 is active.
	<ul style="list-style-type: none"> Parameter set 3 is active.
	<ul style="list-style-type: none"> The "Ex application" function is active.
	<ul style="list-style-type: none"> The soft starter is not ready for operation.

9.3 Warnings and remedial measures of the 3RW55 and 3RW55 Failsafe soft starters

Display of the warnings

The 3RW55 and 3RW55 Failsafe soft starters signal warnings by means of the following displays:

- "MT" LED (yellow)
- 3RW5 HMI High Feature

Display of the warnings on the 3RW5 HMI High Feature

Detailed information about warnings and remedial actions appears in plain text on the display of the 3RW5 HMI High Feature.

Warnings and remedial measures

Warning	Cause	Remedy
Generator operation	The motor is coasting down. The motor connection cables may be energized.	Parameterize the ramp-down mode to minimize or avoid the generator operation.
Connection abort in manual mode	Connection to operator device (e.g. 3RW5 HMI) is interrupted.	<ul style="list-style-type: none"> • Check the communication between the 3RW5 HMI and the device. • Check the connection between PC and the local device interface.
Temperature sensor overload	The temperature of the motor is too high.	<ul style="list-style-type: none"> • Check the motor and the application that is driven by the motor. • After triggering, the motor can only be switched on again if the temperature has reached the release position of the temperature sensor. • The behavior of the soft starter depends on the "Response to overload temperature sensor" parameter that has been set.
Temperature sensor wire break	A wire break has occurred in the sensor line of the temperature sensor.	Check the sensor line and the temperature sensor.
Temperature sensor short-circuit	A short-circuit has occurred in the sensor line of the temperature sensor.	
Preset unequal actual configuration	Real and configured slot of module is different.	Ensure consistency between plugged and configured module position. Possibly the referenced module has a wiring error.

9.3 Warnings and remedial measures of the 3RW55 and 3RW55 Failsafe soft starters

Warning	Cause	Remedy
Switching element too hot for Start	Contact block (switch contact, power semiconductors) too hot.	<ul style="list-style-type: none"> Check the ambient conditions associated with cooling. You may want to consider lowering the operating characteristics. Check the number of switching operations.
New EX parameter values detected	Parameters for the EX motor protection have been received.	Confirm the correctness of the parameters directly on the protection device, or for the protection device.
Remaining time for tripping warning limit undershot	The time to overload trip of the thermal motor model is shorter than the configured time for the tripping reserve.	<ul style="list-style-type: none"> Let the motor cool down. For heavy starting and settings for tripping CLASS 20, deactivate this monitoring.
Motor heating warning limit exceeded	<ul style="list-style-type: none"> The motor feeder is overloaded. The motor temperature has exceeded a limit. 	<ul style="list-style-type: none"> Check the motor and the applications driven by the motor. You can switch on the motor again after the cooling-down period has expired or after deleting the thermal motor model.
Current limit - maintenance demanded exceeded	The current has exceeded a limit.	Check the application driven by the motor.
Current limit - maintenance demanded undershot	The current has undershot a limit.	
Asymmetry limit warning exceeded	<p>A limit for asymmetry has been exceeded. Asymmetry can cause an overload. Possible causes:</p> <ul style="list-style-type: none"> Phase failure Fault in the motor windings 	Check the motor feeder and the motor.
Ground fault limit warning exceeded	The ground-fault monitoring has responded. An impermissibly high residual current is flowing.	Check the connecting cable of the motor for damage.
Switching frequency time not kept	The maximum number of starting operations in the monitoring period has been exceeded.	The next starting operation should take place only after the interlock time has expired.
2-phase control with defective thyristor active ¹⁾	For 3-phase operation, only 2 phases are activated because a power semiconductor is defective.	Check the power semiconductors for L1, L2 and L3 and replace any that are defective.
Main power rotation faulty	The direction of rotation field is not correct.	-
Check fan	<ul style="list-style-type: none"> Internal fan is dirty (not rotating freely). Connecting cable has fallen off or is defective. Internal fan faulty 	<ul style="list-style-type: none"> Check the function of the fan. Clean the fan. Check the wiring. Replace the fan.

Warning	Cause	Remedy
Active power limit - maintenance demanded exceeded	The active power of the motor has exceeded a limit.	Check the application driven by the motor.
Active power limit - maintenance demanded undershot	The active power of the motor has fallen below a limit.	
Starting time limit - maintenance demanded exceeded	The configured maximum starting time is shorter than the required motor starting time.	Prolong the "max. starting time" parameter, increase the current limiting value or check the load coupled with the motor for a mechanical defect.
Starting time limit - maintenance demanded undershot	The configured minimum starting time is longer than the required motor starting time.	Shorten the "min. starting time" parameter, lower the current limiting value or check the load coupled with the motor for a mechanical defect.

1) Not for 3RW55 Failsafe soft starter.

9.4 Errors and remedial actions of the 3RW55 and 3RW55 Failsafe soft starters

Display of the faults

The 3RW55 and 3RW55 Failsafe soft starters signal errors by means of the following displays:

- "ER" LED (red)
- 3RW5 HMI High Feature

Display of faults on the 3RW5 HMI High Feature

Detailed information about errors and remedial actions appears in plain text on the display of the 3RW5 HMI High Feature.

Errors and remedial actions

Error	Cause	Remedy
Switching element overload	Contact block (switch contact, power semiconductors) too hot.	<ul style="list-style-type: none"> • Check the ambient conditions associated with cooling. You may want to consider lowering the operating characteristics. • Check the number of switching operations. • Acknowledgment after cooling down. The acknowledgment depends on the "Response to overload switching element" parameter that has been set.
Switching element defective	<ul style="list-style-type: none"> • Switching element defective • The fault is also generated if the defective switching element (bypass or power semiconductor) cannot be accurately identified. 	Check the switching elements L1, L2, and L3 and replace any that are defective.

9.4 Errors and remedial actions of the 3RW55 and 3RW55 Failsafe soft starters

Error	Cause	Remedy
No main power	<ul style="list-style-type: none"> The mains switch or the power supply is not plugged in correctly. There is no power. 	Check the cables and the cable connections and replace defective components, if necessary.
Temperature sensor overload	The temperature of the motor is too high.	<ul style="list-style-type: none"> Check the motor and the application that is driven by the motor. After triggering, the motor can only be switched on again if the temperature has reached the release position of the temperature sensor. The acknowledgment depends on the "Response to overload temperature sensor" parameter that has been set.
Temperature sensor wire break	A wire has broken in the sensor cable of the temperature sensor.	Check the sensor line and the temperature sensor.
Temperature sensor short-circuit	A short-circuit has occurred in the sensor line of the temperature sensor.	
Thermal motor model overload	<ul style="list-style-type: none"> The motor feeder is overloaded. The motor temperature has exceeded a limit. 	<ul style="list-style-type: none"> Check the motor and the applications driven by the motor. You can switch on the motor again after the cooling-down period has expired or after deleting the thermal motor model. The acknowledgment depends on the set "Response to overload thermal motor model".
Motor overload protection - shutoff		
Safety-related shutoff ¹⁾	The module has detected a problem on the channel and has therefore executed a safety-related shutoff. The possible reason is a discrepancy error.	Check the channel and eliminate the cause.
Asymmetry limit error exceeded	<p>A limit for asymmetry has been exceeded. Asymmetry can cause an overload. Possible causes:</p> <ul style="list-style-type: none"> Phase failure Fault in the motor windings 	Check the motor feeder and the motor.
Asymmetry shutoff	Additional tripping in the case of asymmetry	
Current limit error exceeded	The current has exceeded a limit.	Check the application driven by the motor.
Current limit error undershot	The current has undershot a limit.	
Current limit error shutoff	Additional tripping in the event of a current limit error overshoot or undershoot.	
Ground fault limit error exceeded	The ground-fault monitoring has responded. An impermissibly high residual current is flowing.	Check the connecting cable of the motor for damage.
Electronics supply voltage too low	The supply voltage is below the permitted value.	Check the power supply (load rating, voltage range).
Bus error	<p>Fault in the fieldbus communication. You will find further information in the manual for the 3RW5 communication module in question.</p>	<ul style="list-style-type: none"> Check the bus connection. Check the bus parameters.

9.4 Errors and remedial actions of the 3RW55 and 3RW55 Failsafe soft starters

Error	Cause	Remedy
Error process image	The process image output (PIQ) contains invalid control bit combinations (e.g. control bits for clockwise and counter-clockwise rotation are set at the same time).	Check and correct the process image output (PIQ).
Invalid parameter value	The module is not or is incorrectly parameterized or parameterization changes are denied in current operating mode.	<ul style="list-style-type: none"> Correct and execute parameterization. Switch the operating mode and repeat parameterization.
No external start parameters received	Necessary startup data for the device are missing.	Check parameterization or startup data records.
Self-test error	Unrecoverable error detected after internal diagnostics (self-test, contactor contacts, switching element, etc.).	<p>Switch off the power supply (control supply voltage) for at least 5 seconds and switch it on again. If the fault is still present proceed as follows:</p> <ul style="list-style-type: none"> Please contact Technical Support (Support Request (Page 11)). Replace the device.
Preset unequal actual configuration	Real and configured slot of module is different.	<ul style="list-style-type: none"> Ensure consistency between plugged and configured module. Possibly the referenced module has a wiring error. After the cause is eliminated, the error self-acknowledges.
Motor connection wrong	The motor connection type was not recognized or is different from configuration.	Ensure correct connection.
Missing load	<p>No current flow is detected after the motor feeder is switched on. Possible causes:</p> <ul style="list-style-type: none"> Main circuit interrupted (fuse, circuit breaker) Motor contactor or contactor control is defective No load 	Acknowledgment once the cause has been rectified.
Loss of phase L1	The main power monitoring detects a phase failure.	Acknowledgment once the cause has been rectified.
Loss of phase L2		
Loss of phase L3		
Overvoltage	The supply voltage is above the tolerance limit.	Change the power supply.
Bypass defective	<ul style="list-style-type: none"> Bypass defective The error can also be generated by successive, brief interruptions of the control supply voltage. 	<p>Switch off the power supply (control supply voltage) for at least 5 seconds and switch it on again. If the fault is still present proceed as follows:</p> <ul style="list-style-type: none"> Please contact Technical Support (Support Request (Page 11)). Check bypasses for L1, L2 and L3 and replace any that are defective.

9.4 Errors and remedial actions of the 3RW55 and 3RW55 Failsafe soft starters

Error	Cause	Remedy
Bypass protective shutoff	In bypass operation the current was too high. Fault resetting is only possible after cooling down.	<ul style="list-style-type: none"> • Check motor. • Check dimensioning of the soft starter. • Acknowledgment after cooling down. The acknowledgment depends on the "Response to overload switching element" parameter that has been set.
Switching element L1 failed	Switching element defective	Switch off the power supply (control supply voltage) for at least 5 seconds and switch it on again. If the fault is still present proceed as follows: <ul style="list-style-type: none"> • Please contact Technical Support (Support Request (Page 11)). • Check the switching elements for L1, L2, and L3 and replace any that are defective.
Switching element L2 failed		
Switching element L3 failed		
Phase control failure	<ol style="list-style-type: none"> 1. Error appears without motor start: <ul style="list-style-type: none"> – Motor incorrectly connected – Inside-delta circuit incorrectly realized – Ground fault 2. Error appears while motor is starting: <ul style="list-style-type: none"> – Kick start voltage too high – Breakaway pulse incorrectly set 	<ol style="list-style-type: none"> 1. Check and correct the wiring. 2. Adjust parameters or extend pause time.
Current measuring range exceeded	<ul style="list-style-type: none"> • With sensors: The measured value has exceeded the range limits. • With actuators: The output value has exceeded an upper limit. 	Check the interaction between the module and the sensor or actuator.
Device error	Unrecoverable error detected after internal diagnostics (self-test, contactor contacts, switching element, etc.).	Switch off the power supply (control supply voltage) for at least 5 seconds and switch it on again. If the device error is still present proceed as follows: <ul style="list-style-type: none"> • Please contact Technical Support (Support Request (Page 11)). • Replace the device.
FW update faulty	The firmware is incomplete and / or the firmware expansions are incomplete or incompatible.	<ul style="list-style-type: none"> • Run a complete firmware update. • Check any occurring error messages. • Check to see whether or not the firmware update was aborted.
Switching frequency time not kept	The maximum number of starting operations in the monitoring period has been exceeded.	The next starting operation should take place only after the interlock time has expired.
Main power rotation faulty	The direction of rotation field is not correct.	-

9.5 Faults and remedial actions of the 3RW5 HMI High Feature

Error	Cause	Remedy
Active power limit error exceeded	The active power of the motor has exceeded a limit.	Check the application driven by the motor.
Active power limit error undershot	The active power of the motor has fallen below a limit.	
Active power limit error shutoff	Additional tripping in the event of an active power limit error overshoot or undershoot.	
Main power for test not allowed ²⁾	Current is flowing in the motor feeder even though it is in test mode or in the test position. Possible causes: <ul style="list-style-type: none"> The main circuit is not interrupted in test mode. 	-
Line voltage for test required	<ul style="list-style-type: none"> The mains switch or the power supply is not plugged in correctly. No current 	Check the cables and the cable connections and replace defective components, if necessary.
Operating temperature too high	The temperature in the components has exceeded the maximum limit.	Check the ambient temperature or the control cabinet cooling.
Actuator shutoff	The module has disconnected the actuator. An additional diagnostic message will be displayed to provide you with more detailed information about the cause.	-

¹⁾ For 3RW55 Failsafe soft starters only.

²⁾ Not for 3RW55 Failsafe soft starters.

9.5 Faults and remedial actions of the 3RW5 HMI High Feature

Display of the faults on the 3RW5 HMI High Feature

Detailed information about faults and remedial actions appears in plain text on the display.

Faults and remedial actions

Error	Cause	Remedy
Error HMI	Unrecoverable error detected after internal diagnostics (self-test, etc.).	Replace the device.
FW update not successful	The firmware is incomplete and/or the firmware expansions are incomplete or incompatible.	<ul style="list-style-type: none"> Run a complete firmware update. Check any error messages that occur. Check to see whether or not the firmware update was aborted.
Error during self-test	Unrecoverable error detected after internal diagnostics (self-test, etc.).	Replace the device.

Error	Cause	Remedy
Write Error	File cannot be written to the micro SD card.	<ul style="list-style-type: none"> • Check whether the micro SD card is inserted. • Check whether the micro SD card is write-protected.
FWUpdateInvalidSignature	The firmware is incomplete and/or the firmware expansions are incomplete or incompatible.	<ul style="list-style-type: none"> • Run a complete firmware update. • Check any error messages that occur. • Check to see whether or not the firmware update was aborted.
No device answer	The connection to the connected soft starter has been interrupted.	Check the connection between the HMI and the device.
Loading language unsuccessful ¹⁾	Subsequently loading the language is incomplete and/or the loaded language is incomplete or incompatible.	<ul style="list-style-type: none"> • Ensure the languages are loaded completely. • Check any error messages that occur. • Check to see whether or not loading the language has been interrupted.
Invalid signature 'Load additional language' ¹⁾		

¹⁾ 3RW5 HMI High Feature firmware version V3.0 or higher

9.6 Performing diagnostics on the 3RW55 and 3RW55 Failsafe soft starters using the 3RW5 HMI High Feature

With the diagnosis, you can display different statuses (Diagnosis state, Device state), Statistic data and Maximum pointer of the 3RW55 and 3RW55 Failsafe soft starter. There is also the self-test (user-test) (Page 267) and logbooks (Page 268).

Requirements

Note

Diagnostics on the 3RW55 Failsafe soft starter

Make sure that for diagnostics the 3RW55 Failsafe soft starter is always directly connected to the main supply voltage (operational voltage).

Additional contact elements, such as a redundant contactor, must only be connected in series behind the 3RW55 Failsafe soft starter.

- You are in the "Diagnosis > Soft Starter" menu.

Parameters

Diagnostic value	Description
Diagnosis state	Shows all active warnings and faults. You will find further information on diagnostic messages in chapters Warnings and remedial measures of the 3RW55 and 3RW55 Failsafe soft starters (Page 253) and Errors and remedial actions of the 3RW55 and 3RW55 Failsafe soft starters (Page 255).

9.6 Performing diagnostics on the 3RW55 and 3RW55 Failsafe soft starters using the 3RW5 HMI High Feature

Diagnostic value		Description
Device state	Active parameter set	Display of active parameter set
	Type of connection	If the 3RW55 or 3RW55 Failsafe soft starter is supplied with main supply voltage (operational voltage) and a motor is connected, the motor connection type is automatically detected. <ul style="list-style-type: none"> • Type of motor connection unknown • Type of motor connection standard • Type of motor connection inside delta
	Rotation direction	<ul style="list-style-type: none"> • Unknown (direction of line phase rotation of the main supply voltage (operational voltage) at terminals L1 / L2 / L3 not detected) • CW • CCW
	Device I/Os	Display of active inputs and outputs
	Energy saving mode	Display of the energy saving mode <ul style="list-style-type: none"> • Energy saving mode active
	Ready (automatic)	
	Motor CW	
	Motor CCW	
	Emergency start active	
	Group error	
	Group warning	
	Starting mode active	
	Stopping mode active	
	Electrical braking active ¹⁾	
	Creep speed active ¹⁾	
	Idle time active	
	Cooling time active	
	Current limiting active	
	Input control	
	Input 1	
	Input 2	
	Input 3	
	Input 4	
	Enable Quick-stop	
	Maximum pointer reset	
	CPU/Master STOP	
	Automatic mode	
	Operating mode manual - bus	
	Operating mode manual - local	
	Parameter assignment active	
	Parameters cannot be changed in ON state	
	Parameters disable CPU/master active	
	Self-test active	

9.6 Performing diagnostics on the 3RW55 and 3RW55 Failsafe soft starters using the 3RW5 HMI High Feature

Diagnostic value	Description
	Factory settings restored
	Faulty parameter number
	Parameter set 1 active
	Parameter set 2 active
	Parameter set 3 active
	Parameter set change not possible
	Motor heating active ¹⁾
	DC braking active ¹⁾
	Dynamic DC braking active ¹⁾
	Type of motor connection standard
	Type of motor connection inside delta
	Type of motor connection unknown
	Main power rotation right
	Main power rotation left
	Output 1 active
	Output 2 active
	Output 3 active
	Output 4 active
	Output 1 - Time active
	Output 2 - Time active
	Output 4 - Time active ¹⁾
	Ready to start for motor ON
	Thermal motor model deactivated
	Switching element cooling time active
	Automatic mode
	Operating mode manual - bus
	Manual operation bus - PC controlled
	Operating mode manual - local
	Manual operation local - Input controlled
	Manual operation local - HMI controlled
	Manual operation local - PC controlled
	Manual operation bus - web server controlled
	Automatic operation - Input controlled
	FW update rejected
	FW update active
	FW update successful
	Operation / bypass active
	Start pause pending
	Energy saving mode active
	Normal operation active
	Test mode active
	Start condition not fulfilled ²⁾
	Start condition fulfilled ²⁾

9.6 Performing diagnostics on the 3RW55 and 3RW55 Failsafe soft starters using the 3RW5 HMI High Feature

Diagnostic value	Description
	Reset ON command required ²⁾
	Ex application active
	Ex release denied - wrong CRC
	Pump cleaning active
	Analog output underflow
	Analog output overflow
	Missing initialization after maintenance
	Switching frequency time running
	Switching frequency lock active
	Emergency start enabled
	Emergency run enabled ¹⁾
	Emergency run active ¹⁾
	Alternative stopping mode active
	Reversing DC braking active ¹⁾
	Simulation active
	Test with small load active
	Automatic parameterization active
	Logbook application - error deleted
	Logbook application - warnings deleted
	Logbook application - events deleted
Statistic data ³⁾	Active energy import (total)
	Operating hours - motor
	Reset operating hours motor
	Number of motor overload trips
	Number of starts motor CW
	Number of starts motor CCW
	Number of starts output1
	Number of starts output2
	Number of starts output3
	Number of starts output4
	Number of braking stops
	Phase current max (%)
	Phase current max (rms)
	Last tripping current I_A (%)
	Last tripping current I_A (rms)
	Number of switching element overload trips
	Number of bypass overload trips
	Operating hours – device
	Last real starting time

9.6 Performing diagnostics on the 3RW55 and 3RW55 Failsafe soft starters using the 3RW5 HMI High Feature

Diagnostic value		Description	
Maximum pointer ⁴⁾	Phase currents (%)	Phase current I L1 min (%)	
		Phase current I L2 min (%)	
		Phase current I L3 min (%)	
		Phase current I L1 max (%)	
		Phase current I L2 max (%)	
		Phase current I L3 max (%)	
	Phase currents (rms)	Phase current I L1 min (rms)	
		Phase current I L2 min (rms)	
		Phase current I L3 min (rms)	
		Phase current I L1 max (rms)	
		Phase current I L2 max (rms)	
		Phase current I L3 max (rms)	
	Line-to-line voltages (rms)	Line voltage U L1-L2 min	
		Line voltage U L2-L3 min	
		Line voltage U L3-L1 min	
		Line voltage U L1-L2 max	
		Line voltage U L2-L3 max	
		Line voltage U L3-L1 max	
	Maximum trigger current (%)		
	Maximum trigger current (A)		
	Number of motor overload trips		
Number of starts with ext. bypass ^{1), 5)}			
Minimum line frequency			
Maximum line frequency			
Maximum switching element heating			
Reset maximum pointer	Reset the maximum pointer with this menu item.		
Self-test (user-test)	Performing the self-test (user-test) You will find more information in chapter Self-test (user-test) (Page 267).		
Logbooks	The logbook is a history memory in which events, warnings and faults are shown with a real-time stamp and stored in a list. The logbook can be stored on a micro SD card (Page 245). You will find more information in chapter Logbooks (Page 268).		

¹⁾ Not available with the 3RW55 Failsafe soft starter.

²⁾ Only available with the 3RW55 Failsafe soft starter.

³⁾ The statistic data is based primarily on operating states relating to operating hours and operating frequency of the 3RW55 or 3RW55 Failsafe soft starter in the past.

⁴⁾ Maximum pointers are based on measured values and represent the highest or smallest measured value that occurred in the past.

⁵⁾ 3RW55 soft starter from firmware version V2.0

9.7 Execute HMI diagnostics with the 3RW5 HMI High Feature

With the diagnosis, you can display the diagnosis state of the 3RW5 HMI High Feature and check correct functioning of the 3RW5 HMI High Feature with various tests.

Requirements

- 3RW5 HMI High Feature
Menu: "Diagnosis > HMI"

Note**Self-tests**

To be able to start the self-tests with a 3RW5 HMI High Feature with firmware version V3.1, the motor connected to the 3RW5 soft starter must be switched off.

3RW5 HMI High Feature with firmware version V3.1 or earlier: During the self-test, you cannot switch off the motor on the 3RW5 HMI High Feature. If you are controlling the motor via the 3RW5 HMI High Feature, switch off the motor before a self-test.

Parameter

Diagnostic value		Comment
Diagnosis state		Shows all active diagnostic messages (faults, warnings, device state).
Self-test	Test LEDs	The device LEDs of the 3RW5 HMI High Feature are tested one after the other. The display shows which device LED is currently being controlled. Navigate through the test operation with the OK key.
	Test buttons	The 3RW5 HMI High Feature keys are tested one after the other. The display shows which keys must be actuated in sequence in order to perform the test.
	Test display	The 3RW5 HMI High Feature runs a color program on the display. Navigate through the test operation with the OK key.

9.8 Performing diagnostics of the 3RW5 communication module with the 3RW5 HMI High Feature

With the diagnosis, you can display the diagnosis state of the 3RW5 communication module.

Requirements

- 3RW5 HMI High Feature
Menu: "Diagnosis > Communication module"
- 3RW5 communication module (accessory)

Parameter

Diagnostic value	Comment
Diagnosis state	Shows all active prewarnings and faults. You can acknowledge faults here. A 3RW5 PROFINET High Feature communication module also shows the device state.

Additional information

You will find further information on the diagnostics of the 3RW5 communication module in the Equipment Manual for the respective 3RW5 communication module.

9.9 Self-test (user-test)

With the self-test (user-test), you can test correct functioning of the 3RW55 and 3RW55 Failsafe soft starters (LEDs, current measurement, electronic motor overload protection, F-RQ failsafe signaling output).

Requirements

- The 3RW55 or 3RW55 Failsafe soft starter is in the error-free condition.
- Perform the test with the motor switched off.

Activation on the 3RW5 HMI High Feature

- Menu: "Diagnosis > Soft Starter > Self-test"
- The 3RW5 HMI High Feature (LOCAL) has master control.
- Access protection to 3RW5 HMI High Feature is not active or has been reset.

Operating principle

Start the self-test (user-test) via the 3RW5 HMI High Feature. The self-test (user-test) is performed as follows:

- LED test
All LEDs are controlled (3RW5 soft starter and 3RW5 HMI High Feature).
- Current measurement test
The current detection is tested in all 3 phases.
On the display of the 3RW5 HMI High Feature, the average phase current (%) relative to the rated operational current I_e is displayed. The thermistor motor protection is tested for short circuits and overload.
- Test of the electronic motor overload protection
The entire control circuit is tested, including the switching elements and the error signaling output.
- Test of the F-RQ failsafe signaling output (output 41, 42) on the 3RW55 Failsafe soft starter (function test)

Result

If the 3RW55 or 3RW55 Failsafe soft starter performs the self-test (user-test) as specified, the 3RW55 or 3RW55 Failsafe soft starter responds with an overload trip after approx. 5 seconds. The error message for "Motor overload protection - shutoff" appears on the display of the 3RW5 HMI High Feature. You can reset this error message immediately without observing the cooling time with the "Reset" function.

If the 3RW55 or 3RW55 Failsafe soft starter does not pass the self-test (user-test), the 3RW5 HMI High Feature signals a device error.

Self-test of the 3RW5 HMI High Feature

You will find more information on the self-test of the 3RW5 HMI High Feature in chapter Execute HMI diagnostics with the 3RW5 HMI High Feature (Page 266).

9.10 Logbooks

Operating principle

The logbook lists events, warnings, and faults in chronological order. Each of these events is given a real-time stamp. The 3RW55 and 3RW55 Failsafe soft starters have the following logbooks:

- Application logbook
- Device logbook
- Service logbook
- Security logbook

The logbook is designed as a circular buffer.

Display and editing options

- 3RW5 HMI High Feature
Menu: "Diagnosis > Soft Starter > Logbook"
- With SIRIUS Soft Starter ES (TIA Portal) via the local interface on the 3RW5 HMI High Feature
Brief overview: Window "Project Navigation" with current project under created Soft Starter > "Commissioning" > Window "Work area" > "Soft Starter > Logbook"
- With a fieldbus via a 3RW5 communication module (only via a 3RW5 PROFINET or PROFIBUS communication module):
 - With SIRIUS Soft Starter ES (TIA Portal) Premium / Professional
Brief overview: See SIRIUS Soft Starter ES (TIA Portal) via the local interface on the 3RW5 HMI High Feature
 - Configuration software of the control system (e.g. STEP 7 with corresponding HSP)

Application logbook

The application logbook contains all messages relating to functions and parameters. The logbook application can be deleted.

Device logbook

The following messages are recorded in the device logbook:

- Errors
- Warnings
- Event

The device logbook is available in every module (3RW55 soft starter, 3RW55 Failsafe soft starter, 3RW5 HMI High Feature, 3RW5 communication module) and cannot be deleted.

Service logbook

Messages about device errors, deactivation of protective functions, etc., are recorded in the service logbook. The service logbook cannot be deleted.

Security logbook

The security logbook records all messages of the security functions. The security logbook cannot be deleted.

Saving logbooks

- You can save the logbooks on a micro SD card (Page 245) if a micro SD card is inserted in the HMI HF:
 - Menu: "Micro SD card > Save logbooks to micro SD card"
 - Click "OK". A *.csv file is stored on the micro SD card, which you can read out with Microsoft Excel, for example.

9.11 Save service data to micro SD card

Requirements

- 3RW55 soft starter from firmware version V2.0 or 3RW55 Failsafe soft starter from firmware version V1.0
- 3RW5 HMI High Feature firmware from version V2.0
Menu: "Micro SD card"
The "micro SD Card" menu appears after you have inserted a micro SD card into the 3RW5 HMI High Feature.
- Inserted micro SD card (Page 245)

9.11 Save service data to micro SD card

- Access protection to the 3RW5 HMI High Feature is not active or has been reset.
- Motor switched off

Operating principle

The 3RW55 and 3RW55 Failsafe soft starters record service data during starting and stopping. If problems occur in the system in conjunction with the 3RW55 or 3RW55 Failsafe soft starter, you can save the service data on the micro SD card. The service data can help Technical Support to handle the case in the event of a Support Request (Page 11). The service data contain the following data, for example:

- Parameters
- Logbooks
- Statistic data
- Maximum pointer
- I&M data

Procedure

Save the service data on the 3RW5 HMI High Feature onto the micro SD card.

Menu: "Micro SD card > Save service data to micro SD card"

Saving the service data can take a little time (> 1 minute). At the top level of the micro SD card, a folder is created with the serial number of the 3RW55 or 3RW55 Failsafe soft starter in which the service data is stored. Example of a created folder name: "1P3RW5 xxx-xxxxx+SLO..."

Note

Save service data to micro SD card

While the service data are being saved to the micro SD card, the color of the micro SD card icon changes from blue to red on the display 3RW5 HMI High Feature. If the service data have been saved completely, the color of the icon changes back to blue.

Icon of the micro SD card on the display of the 3RW5 HMI High Feature:



Result

You have stored the service data on the micro SD card.

These service data can help Technical Support to handle the case in the event of a Support Request (Page 11). If necessary, read the micro SD card in at a PC and send the folder of service data as a ZIP file.

Maintenance and service

10.1 Maintenance and repairs



! WARNING

**Hazardous voltage.
Can cause death or serious injury.**

The present device/part conducts hazardous voltages.

Touching live components will result in death or severe injury.

Installation, commissioning, and maintenance only by qualified specialist personnel.

Repair of the devices is only permissible by qualified personnel. Please contact the authorized Siemens service partner for this.

Note

Loss of ATEX/IECEX/UKEX approval

The repair of soft starters with approval according to IEC 61508 / EN ISO 13849 is only permissible in the manufacturer's plant.

Any repair to the 3RW55 and 3RW55 Failsafe soft starters that is not performed in the manufacturer's plant will result in loss of ATEX/IECEX/UKEX approval.

Note

Loss of failsafe approval

The repair of soft starters with approval according to IEC 61508 / EN ISO 13849 is only permissible in the manufacturer's plant.

Any repair to the 3RW55 Failsafe soft starters that is not performed in the manufacturer's plant will result in loss of Failsafe approval.

10.2 Replacing the fan

Requirements

- Replacement fan, incl. connector (connector is not relevant for size 5)
- Optional: The fan cover is disassembled.
- Flat-head screwdriver (size 1)

10.2 Replacing the fan

- Diagonal cutter (sizes 1 ... 4)
- Pliers (size 1 ... 4)

Procedure for size 1 (3RW551.-.....)



! DANGER
Hazardous voltage.
Will cause death or serious injury.
Disconnect the system and the device from the power supply before starting work.

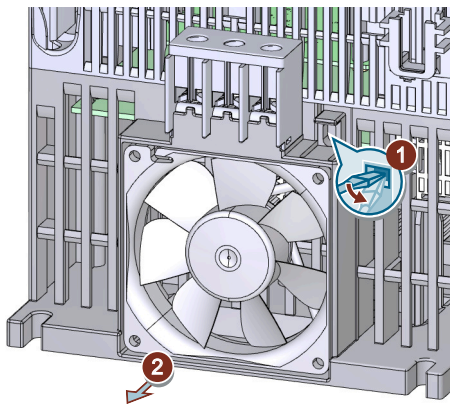

On the underside of the soft starter, insert a flat-head screwdriver into the opening on the right above the fan. Press the flat-head screwdriver down ① until the tab opens upward. Remove the defective fan ② and cut the cables at the fan.

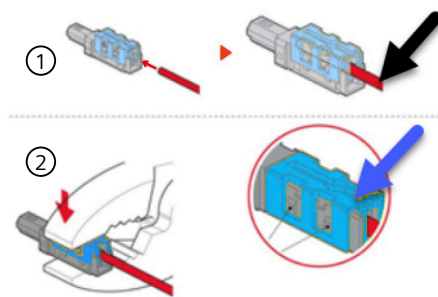

Connect the cables using the connector supplied as a separate item ① and ②. Carefully ensure the correct polarity (red and black).

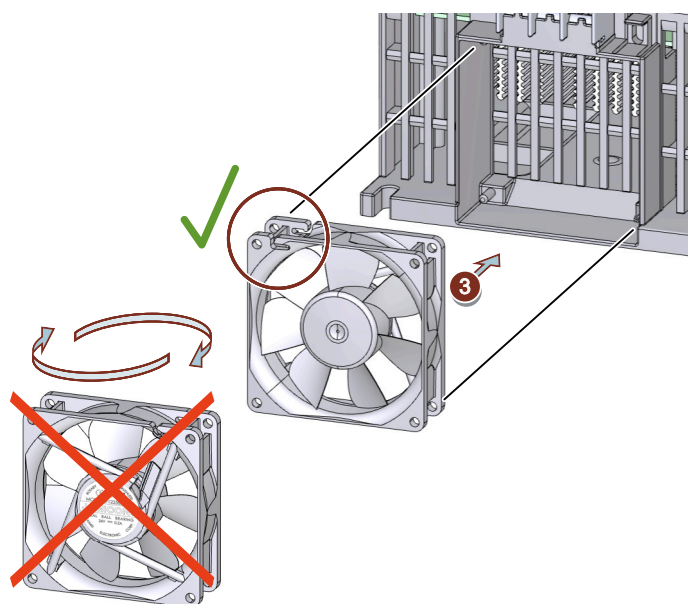

Fit the replacement fan ③ until it engages:

- The adhesive label faces inward.
- The cable guide is top left. It ensures that the cable is correctly routed.
- Ensure that the cable is not crushed.

Procedure for sizes 2 and 3 (3RW552.-..... and 3RW553.-.....)



! DANGER

**Hazardous voltage.
Will cause death or serious injury.**

Disconnect the system and the device from the power supply before starting work.

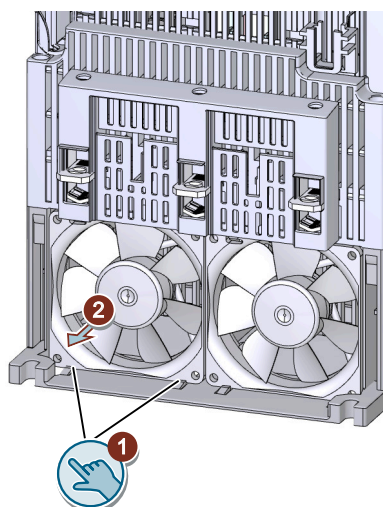

10.2 Replacing the fan

On the underside of the soft starter, push the lugs to the left and right of the fan downward ①.

Remove the defective fan ② and cut the cables at the fan.

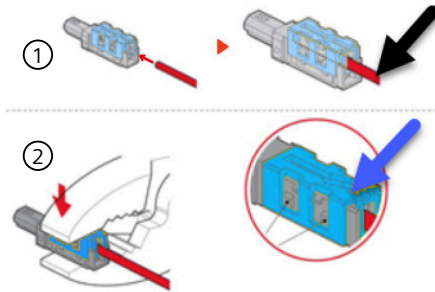

Connect the cables using the connector supplied as a separate item ① and ②. Carefully ensure the correct polarity (red and black).

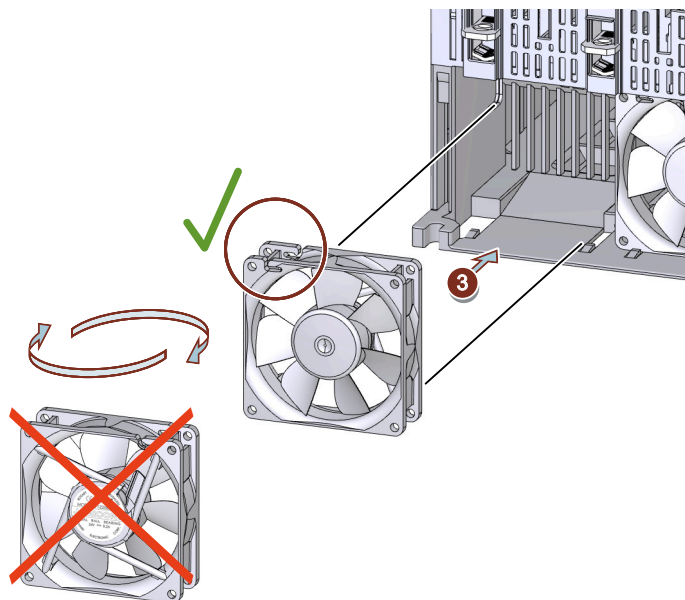

Fit the replacement fan ③ until it engages:

- The adhesive label faces inward.
- The cable guide is top left.
- Ensure that the cable is not crushed.

Procedure for size 4 (3RW554.-.....)

! DANGER

**Hazardous voltage.
Will cause death or serious injury.**

Disconnect the system and the device from the power supply before starting work.

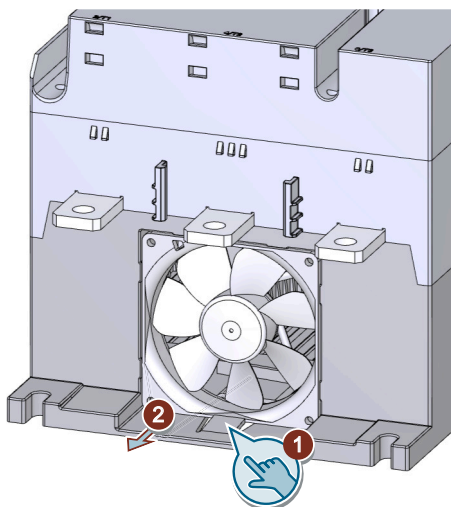

On the underside of the soft starter, push the lug at the bottom in the center of the fan downward ①.

Remove the defective fan ② and cut the cables at the fan.

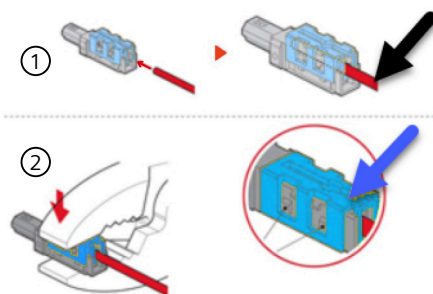

Connect the cables using the connector supplied as a separate item ① and ②. Carefully ensure the correct polarity (red and black).

10.2 Replacing the fan

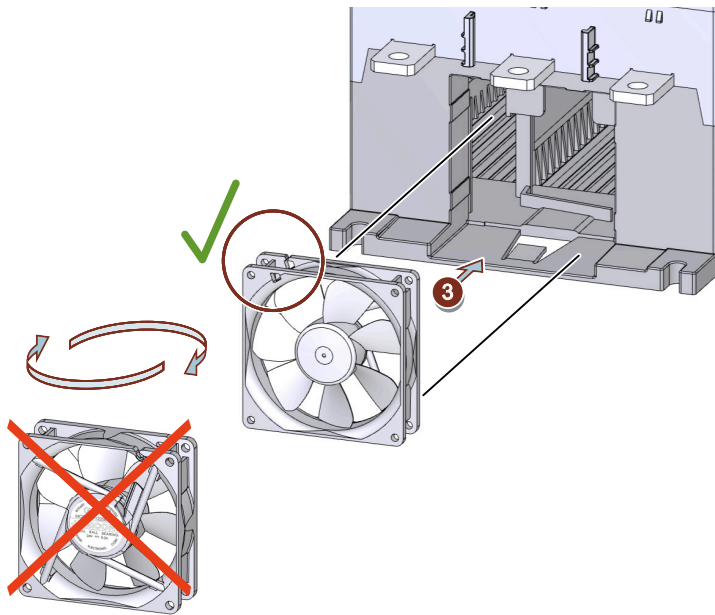

Fit the replacement fan ③ until it engages:

- The adhesive label faces inward.
- The cable guide is top left.
- Ensure that the cable is not crushed.

Procedure for size 5 (3RW555-.....)



! DANGER
Hazardous voltage.
Will cause death or serious injury.
Disconnect the system and the device from the power supply before starting work.

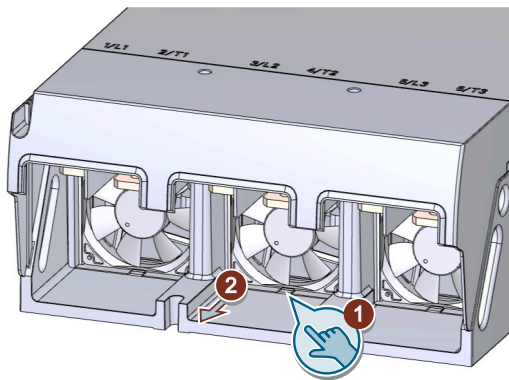

On the underside of the soft starter, push the lug at the bottom in the center of the fan downward ①.

Remove the defective fan ② and disconnect the cable.

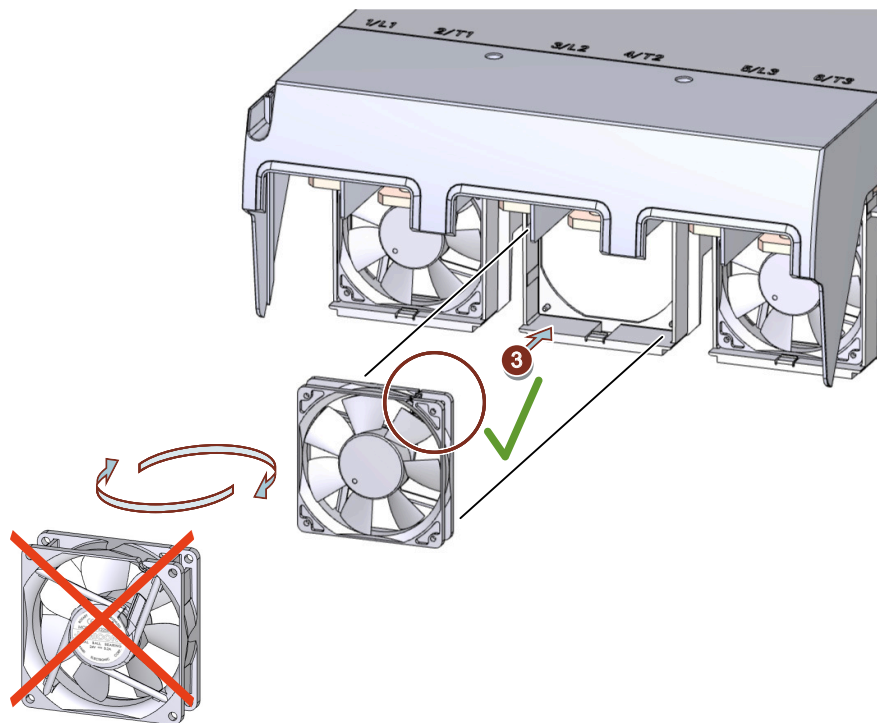

Connect the cable and fit the replacement fan ③ until it engages:

- The adhesive label faces inward.
- The cable guide is top right.
- Ensure that the cable is not crushed.

10.3 Firmware update

During operation, it may be necessary to update the firmware (e.g. to extend the available functions). You update the firmware of the respective device with the help of device-specific firmware files. The retentive data is retained after the firmware has been updated.

Firmware updates and a history of the versions with the innovations are provided to you on the Internet. Depending on what firmware updates are available, you can update the devices individually or together.

You can perform a firmware update for the following devices:

- 3RW55 or 3RW55 Failsafe soft starter
- 3RW5 HMI High Feature (not possible via fieldbus)
- 3RW5 communication modules

Requirements

- Valid firmware update
You will find the latest firmware files on the 3RW5 topic page (<https://support.industry.siemens.com/cs/ww/en/view/109747404>).
- For operation of an application in Class I and Class II Hazardous Locations:

 DANGER
Loss of certified motor overload protection according to ATEX/IECEX/UKEX. Can cause death or serious injury.
A certified motor overload protection according to ATEX/IECEX/UKEX is only provided for 3RW55 soft starters from firmware version V2.0 (does not apply to 3RW55 Failsafe soft starters).
Note that it is not permissible to downgrade to a previous firmware version because otherwise certified motor overload protection according to ATEX/IECEX/UKEX cannot be guaranteed.

Procedure

1. Make sure that the motor is switched off and you do not start the motor during the firmware update.
A control command for starting the motor is not supported during the firmware update. To ensure the quickest and most fault-free firmware update, it is recommended that you disconnect the main supply voltage (operational voltage) of the 3RW55 and 3RW55 Failsafe soft starters and put the CPU / PLC into the STOP state.
2. Perform the update of the device firmware.
The following procedures are possible:
 - With a micro SD card via the 3RW5 HMI High Feature (Page 279)
 - Via the local interface of the 3RW5 HMI High Feature with SIRIUS Soft Starter ES (TIA Portal)
Brief overview: Window "Project Navigation" with current project under created Soft Starter > "Online & Diagnostics" > Window "Work area" > "Soft Starter / 3RW5 communication module used / HMI > Functions > Firmware Update"
 - With a fieldbus via a 3RW5 communication module with SIRIUS Soft Starter ES (TIA Portal) Premium / Professional or the configuration software of the controller (e.g. STEP 7 with corresponding HSP) (via a 3RW5 PROFINET or PROFIBUS communication module only)

Note

Firmware update of the 3RW5 PROFINET High Feature communication module

The firmware update of the 3RW5 PROFINET High Feature communication module via SIRIUS Soft Starter ES (TIA Portal) at the local interface or using a micro SD card via the 3RW5 HMI High Feature can take a very long time in comparison with other options (up to about 60 minutes).

Result

You have performed a firmware update for the selected device. The selected device automatically restarts.

Note**Firmware update of the 3RW5 HMI High Feature:**

Please note that the display switches off for about 30 seconds when the firmware is activated.

10.4 Performing firmware update with micro SD card (3RW5 HMI High Feature)

Requirements

- Micro SD card with valid firmware file (*.upd)
- The valid firmware file is located in the root directory (topmost level)
- 3RW5 HMI High Feature
Menu: "Micro SD card > FW update"
- Access protection to 3RW5 HMI High Feature is not active or has been reset.

Procedure

Note**Access to micro SD card.**

Please note that the micro SD card is inserted in the 3RW5 HMI High Feature during updating of the firmware.

Premature removal of the micro SD card from the 3RW5 HMI High Feature is not permissible and will terminate updating of the firmware. Data could also be lost.

1. Select the folder of the respective device.
2. Select the firmware file of the device and confirm with the OK key.
You can see the firmware update is being performed from the progress bar on the display. Following successful updating of the firmware, the respective device then restarts automatically.

Note**Firmware update of the 3RW5 HMI High Feature:**

Please note that the display switches off for about 30 seconds when the firmware is activated.

3. Check the new firmware version in the "Overview" menu.

Result

You have performed a firmware update for the selected device using the micro SD card.

10.5 Restoring factory setting

Effects of the factory setting

The following devices can be reset to the factory setting:

- 3RW55 or 3RW55 Failsafe soft starter
 - The parameters of the 3RW55 or 3RW55 Failsafe soft starter are reset to the factory setting.
 - User accounts are deleted.
 - Ex-relevant parameters are reset.
You will find further information on Ex operation in chapter ATEX/IECEX/UKEX (Page 208).
- 3RW5 communication module
 - The parameters of the 3RW5 communication module are reset.
- 3RW5 HMI High Feature
 - The parameters of the 3RW5 HMI High Feature and the PIN for access protection are reset to the factory setting.
- All devices
 - The 3RW55 or 3RW55 Failsafe soft starter, the 3RW5 communication module, and the 3RW5 HMI High Feature are reset to the factory settings, as described above.

Requirements

The control priority lies with the source of the command to restore the factory setting.

 DANGER
Restoring the factory setting with active Ex operation. Will cause death or serious injury.
Restoring the factory setting with active Ex operation (Page 209) is not permissible for all procedures.
To restore the factory setting with active Ex operation, choose the procedure using the master RESET key on the 3RW5 HMI High Feature (Page 282).

Procedure

1. Make sure that the motor is switched off and you do not start the motor while restoring the factory settings.
To ensure the quickest and most fault-free restoration of the factory setting, it is recommended that you disconnect the main supply voltage (operational voltage) at the 3RW55 and 3RW55 Failsafe soft starters.
2. Restore the factory settings.
The following procedures are possible:
 - Via the 3RW5 HMI High Feature:
Restoring the factory settings via High Feature 3RW5 HMI (Page 281)
Restoring the factory settings with the Master RESET button via 3RW5 HMI High Feature (Page 282)
 - Via the local interface on the 3RW5 HMI High Feature with SIRIUS Soft Starter ES (TIA Portal)
Brief overview: Window "Project Navigation" with current project under created Soft Starter > "Commissioning" > Window "Work area" > "Soft Starter > Functions > Commands > Factory settings"
 - With a fieldbus via a 3RW5 communication module with SIRIUS Soft Starter ES (TIA Portal) Premium / Professional (only via a 3RW5 PROFINET or PROFIBUS communication module)
Brief overview: See SIRIUS Soft Starter ES (TIA Portal) via local interface on the 3RW5 HMI High Feature
 - With a fieldbus via a 3RW5 communication module with the command "Factory settings" in data set 93 (only via a 3RW5 PROFINET or PROFIBUS communication module):
 - With a fieldbus via a 3RW5 communication module with the configuration software of the control (only via a 3RW5 PROFINET or EtherNet/IP communication module). Only the communication parameters are reset here.

Result

The factory setting of the selected device or all devices is restored.

10.5.1 Restoring the factory settings via High Feature 3RW5 HMI

Requirements

- Make sure that the motor is switched off and you do not start the motor while restoring the factory settings. To ensure the quickest and most fault-free restoration of the factory setting, it is recommended that you disconnect the main supply voltage (operational voltage) at the 3RW55 and 3RW55 Failsafe soft starters.
- 3RW5 HMI High Feature
Menu: "Parameters > Factory settings"
- Access protection to 3RW5 HMI High Feature is not active or has been removed.
- The 3RW5 HMI High Feature (LOCAL) has master control.

 **DANGER**

**Restoring the factory setting with active Ex operation.
Will cause death or serious injury.**

Restoring the factory setting with active Ex operation (Page 209) is not permissible for this procedure.

To restore the factory setting with active Ex operation, choose the procedure using the master RESET key on the 3RW5 HMI High Feature (Page 282).

Procedure

1. Select the desired menu item.
 - Soft starter
 - Communication module
 - HMI High Feature
 - All devices
2. Confirm the menu item by pressing the OK key.

Result

The factory setting of the selected device or all devices is restored.

Note the effects of the factory settings (Page 280).

10.5.2 Restoring the factory settings with the Master RESET button via 3RW5 HMI High Feature

Requirements

- Make sure that the motor is switched off and you do not start the motor while restoring the factory settings. To ensure the quickest and most fault-free restoration of the factory setting, it is recommended that you disconnect the main supply voltage (operational voltage) at the 3RW55 and 3RW55 Failsafe soft starters.
- Free access to the Master RESET key of the 3RW5 HMI High Feature.
Removing the 3RW5 HMI High Feature (Page 62)
- 3RW5 HMI High Feature is connected to the 3RW55 or 3RW55 Failsafe soft starter via the HMI connecting cable.

 **DANGER**

**Resetting of ex-relevant parameters to the factory setting.
Will cause death or serious injury.**

Ex-relevant parameters are deleted on restoration of the factory setting.

Restoration of the factory setting with active Ex operation (Page 209) is only permissible via the master RESET button on the 3RW5 HMI High Feature. After restoration of the factory setting, you have to parameterize the 3RW55 or 3RW55 Failsafe soft starter again for use in Class I and Class II Hazardous Locations. You will find further information on parameterization of the 3RW55 and 3RW55 Failsafe soft starters for use in Class I and Class II Hazardous Locations in chapter ATEX/IECEX/UKEX (Page 208).

Procedure

1. Press the Master RESET key on the rear of the 3RW5 HMI High Feature.
The menu for restoring the factory setting appears on the display.
2. Select the desired menu item.
 - Soft starter
 - Communication module
 - HMI High Feature
 - All devices
3. Confirm the menu item by pressing the OK key.

Result

The factory setting of the selected device or all devices is restored.

Note the effects of the factory settings (Page 280).

10.6 "Device change" function



 **WARNING**

**Hazardous voltage.
Can cause death or serious injury.**

The present device/part conducts hazardous voltages.

Touching live components will result in death or severe injury.

Installation, commissioning, and maintenance only by qualified specialist personnel.

The device replacement is only permissible by qualified personnel.

Operating principle

If the 3RW55 or 3RW55 Failsafe soft starter, the 3RW5 HMI High Feature or the 3RW5 communication module (accessory) has to be replaced because of a fault, you can transfer data to your new device (identical type) using the "Device change" function or SIRIUS Soft Starter ES (TIA Portal). To be able to transfer data, you must first save it.

The following data is transferred with the "Device change" function:

- I&M 1 data
- I&M 3 data
- Device parameters of the 3RW55 and 3RW55 Failsafe soft starters
- Device parameters of the 3RW5 HMI High Feature
- User administration / passwords
- Communication parameters

Note the information in chapter Firmware update (Page 24).

Transmission options

- Device change with micro SD card on the 3RW5 HMI High Feature (Page 284)
- Device change with SIRIUS Soft Starter ES (TIA Portal) (Page 285)

10.6.1 Device change with micro SD card on the 3RW5 HMI High Feature

Requirements

- Micro SD card with the saved data (Page 245)
 - The folder (e.g. "1P3RW5 xxx-xxxxx+SLO...") is located in the root directory (top level).
 - The article number in the name of the folder must match the article number of the 3RW55 or 3RW55 Failsafe soft starter. The serial number in the name of the folder ("SLO...") does not need to match.
 - Menu: "Micro SD card > Save parameter settings to micro SD card"
The data is saved in an automatically generated folder (e.g. "1P3RW5 xxx-xxxxx+SLO...").

Procedure

1. Plug the micro SD card into the 3RW5 HMI High Feature.
2. Transfer the data to the devices (3RW55 or 3RW55 Failsafe soft starter, 3RW5 HMI High Feature, 3RW5 communication module).
Menu: "Micro SD card > Device change"

Note

Device change

The current data of all devices (3RW55 or 3RW55 Failsafe soft starter, 3RW5 HMI High Feature, 3RW5 communication module) is overwritten by the data on the micro SD card.

3. Check the transferred data.

Result

You have transferred your saved data to your devices (3RW55 or 3RW55 Failsafe soft starter, 3RW5 HMI High Feature, 3RW5 communication module) with the "Device change" function.

10.6.2 Device change with SIRIUS Soft Starter ES (TIA Portal)

Requirements

- Accessories (optional), e.g. 3RW5 PROFINET or PROFIBUS communication module
- Connection of the 3RW55 or 3RW55 Failsafe soft starter to SIRIUS Soft Starter ES (TIA Portal). The 3RW55 or 3RW55 Failsafe soft starter must not be connected online to SIRIUS Soft Starter ES (TIA Portal).
- Project in SIRIUS Soft Starter ES (TIA Portal) with saved data (identical type)
Button: "Upload from device" on the toolbar.
In the "Project Navigation" window, the 3RW55 or 3RW55 Failsafe soft starter must be selected in the current project so that the button can be operated.

Procedure

1. Transfer the data to the devices (3RW55 or 3RW55 Failsafe soft starter, 3RW5 HMI High Feature, 3RW5 communication module) with SIRIUS Soft Starter ES (TIA Portal).
Button: "Download to device" on the toolbar.
In the "Project Navigation" window, the 3RW55 or 3RW55 Failsafe soft starter must be selected in the current project so that the button can be operated.

Note

Device change

The data of all devices (3RW55 or 3RW55 Failsafe soft starter, 3RW5 HMI High Feature, 3RW5 communication module) is overwritten by the transferred data.

2. Check the transferred data.

Result

You have transferred your saved data to your devices (3RW55 or 3RW55 Failsafe soft starter, 3RW5 HMI High Feature, 3RW5 communication module) with SIRIUS Soft Starter ES (TIA Portal).

Technical specifications

11.1 Technical specifications in the Siemens SiePortal

Technical data sheet

You can find the technical specifications for the product in Siemens SiePortal (<https://sieportal.siemens.com/su/bldxc>).

1. Enter the article number of the desired device in the "Products" field.
2. Click the "Technical specifications" link in the result.

Overview tables technical data

You will find overview tables with technical data in the "Product information" tab in our online ordering system (<https://mall.industry.siemens.com/mall/en/WW/Catalog/Products/10341685?tree=CatalogTree>).

Dimension drawings

12.1 CAx data in the Siemens SiePortal

You can find CAx data for the product in the SiePortal (<https://sieportal.siemens.com/su/bldxc>).

1. Enter the article number of the desired device in the "Products" field.
2. Click the "CAx data" link in the result.

12.2 Drilling pattern for 3RW5 HMI High Feature

The drilling pattern below supports you when installing a 3RW5 HMI High Feature with push-in lugs on a level surface.

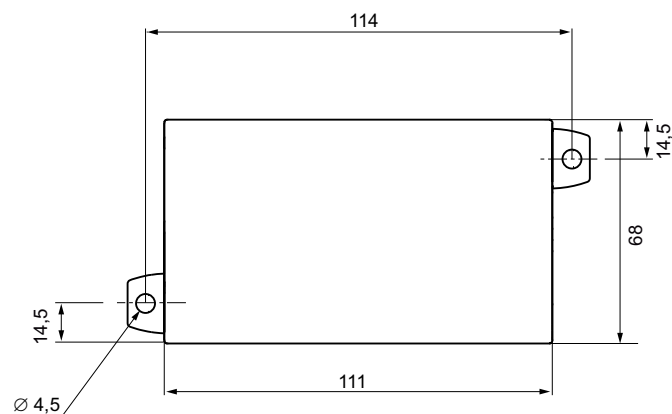

Circuit diagrams

13.1 CAx data in the Siemens SiePortal

You can find CAx data for the product in the SiePortal (<https://sieportal.siemens.com/su/bldxc>).

1. Enter the article number of the desired device in the "Products" field.
2. Click the "CAx data" link in the result.

Example circuits

A.1 Main circuit connection

A.1.1 Feeder assembly, type of coordination 1 fuseless

Requirements

- 3RW55 or 3RW55 Failsafe soft starter
- The motor connection type (Page 97) is parameterized as "Automatic detection" or "Standard".

Feeder assembly

Connect the 3RW55 or 3RW55 Failsafe soft starter at its terminals to the motor feeder between the motor starter protector and the motor. This achieves coordination type 1.

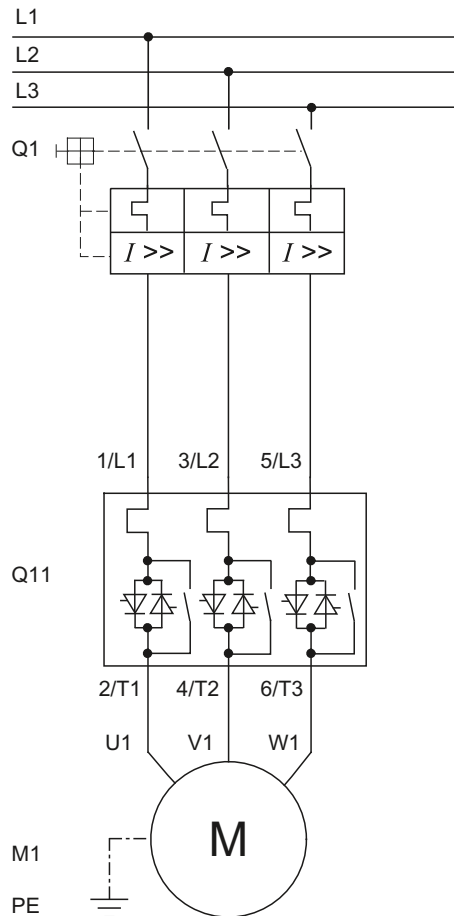

- Q1 Motor starter protector (e.g. 3RV2 or 3VA)
- Q11 3RW55 or 3RW55 Failsafe soft starter
- M1 Motor
- PE Protective conductor

A.1.2 Feeder assembly, type of coordination 1 with fuses

Requirements

- 3RW55 or 3RW55 Failsafe soft starter
For the 3RW55 Failsafe soft starter, note that a Q21 line contactor must be switched on before the start command so that the 3RW55 Failsafe soft starter can run the device test before switch-on.
- The motor connection type (Page 97) is parameterized as "Automatic detection" or "Standard".

Feeder assembly

If galvanic isolation is required, install a main or line contactor between the 3RW55 or 3RW55 Failsafe soft starter and the fuses.

Do not connect the main or line contactor between the 3RW55 or 3RW55 Failsafe soft starter and the motor. The 3RW55 or 3RW55 Failsafe soft starter could otherwise display a "Missing load" error message in the event of a start command and delayed connection of the contactor.

A.1 Main circuit connection

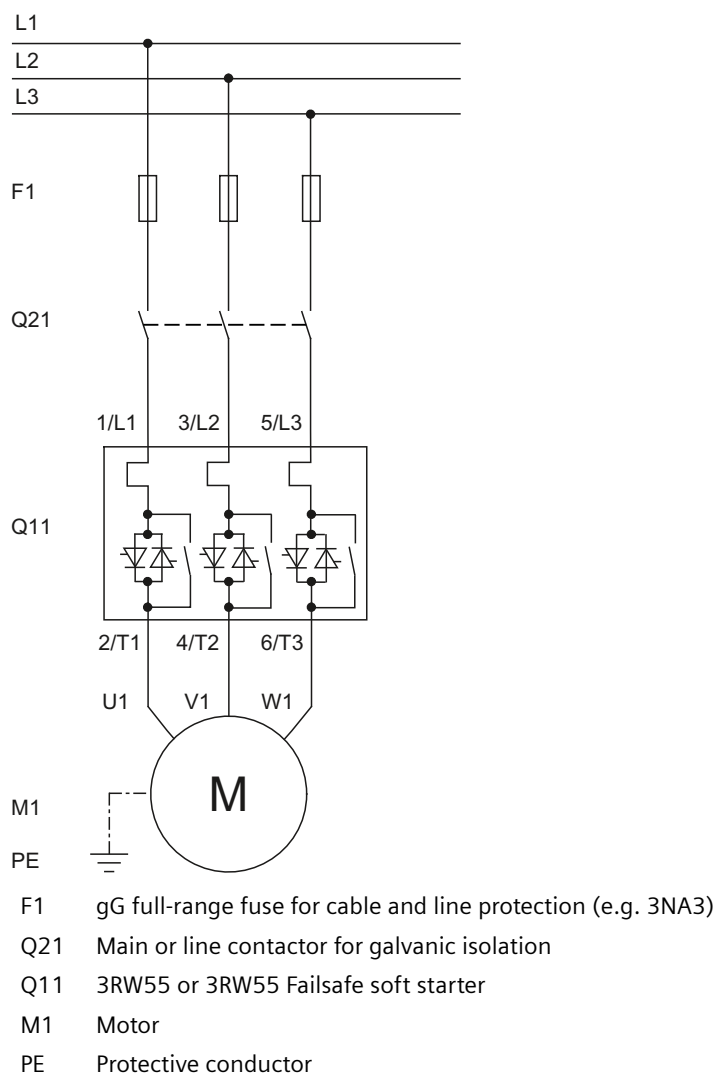

A.1.3 Feeder assembly, type of coordination 2

Requirements

- 3RW55 or 3RW55 Failsafe soft starter
- The motor connection type (Page 97) is parameterized as "Automatic detection" or "Standard".

Feeder assembly

You must provide protection for all power semiconductors against short circuits by means of special semiconductor fuses (e.g. SITOR fuses from Siemens) to achieve coordination type 2. A short circuit can occur, for instance, as a result of a defect in the motor windings or in the motor's power supply cable.

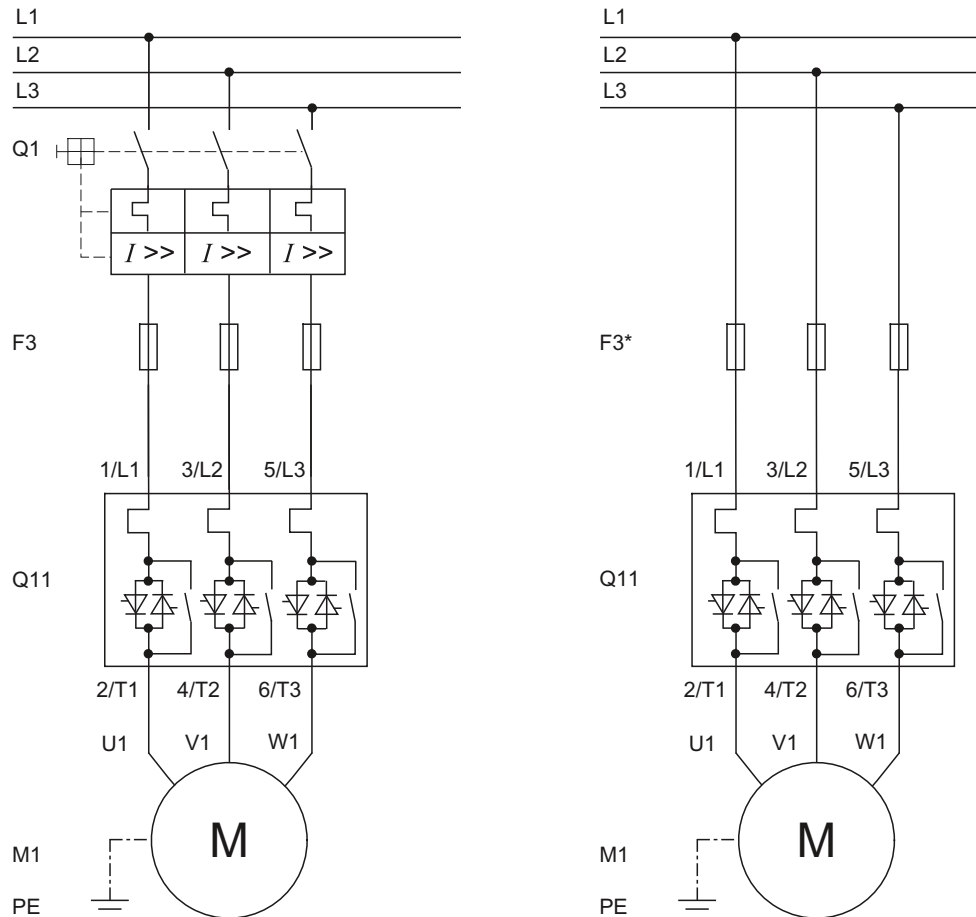

- Q1 Motor starter protector
- F3 aR partial-range fuse for protection of semiconductors (e.g. SITOR 3NE3/4 or 3NC3)
- F3* gR full-range fuse for protection of semiconductors (e.g. SITOR 3NE1)
- Q11 3RW55 or 3RW55 Failsafe soft starter
- M1 Motor
- PE Protective conductor

A.1.4 Inside-delta circuit

If the 3RW55 or 3RW55 Failsafe soft starter is operated in an inside-delta circuit, the motor power output of the individual devices is increased by a factor of root 3.

Requirements

- 3RW55 or 3RW55 Failsafe soft starter
For the 3RW55 Failsafe soft starter, note that a Q21 line contactor must be switched on before the start command so that the 3RW55 Failsafe soft starter can run the device test before switch-on.
- Motor with windings that can be connected in a delta with line voltage predominating.
- The motor connection type (Page 97) is parameterized as "Automatic detection" or "Inside-delta".

Motor rotation in line phase direction

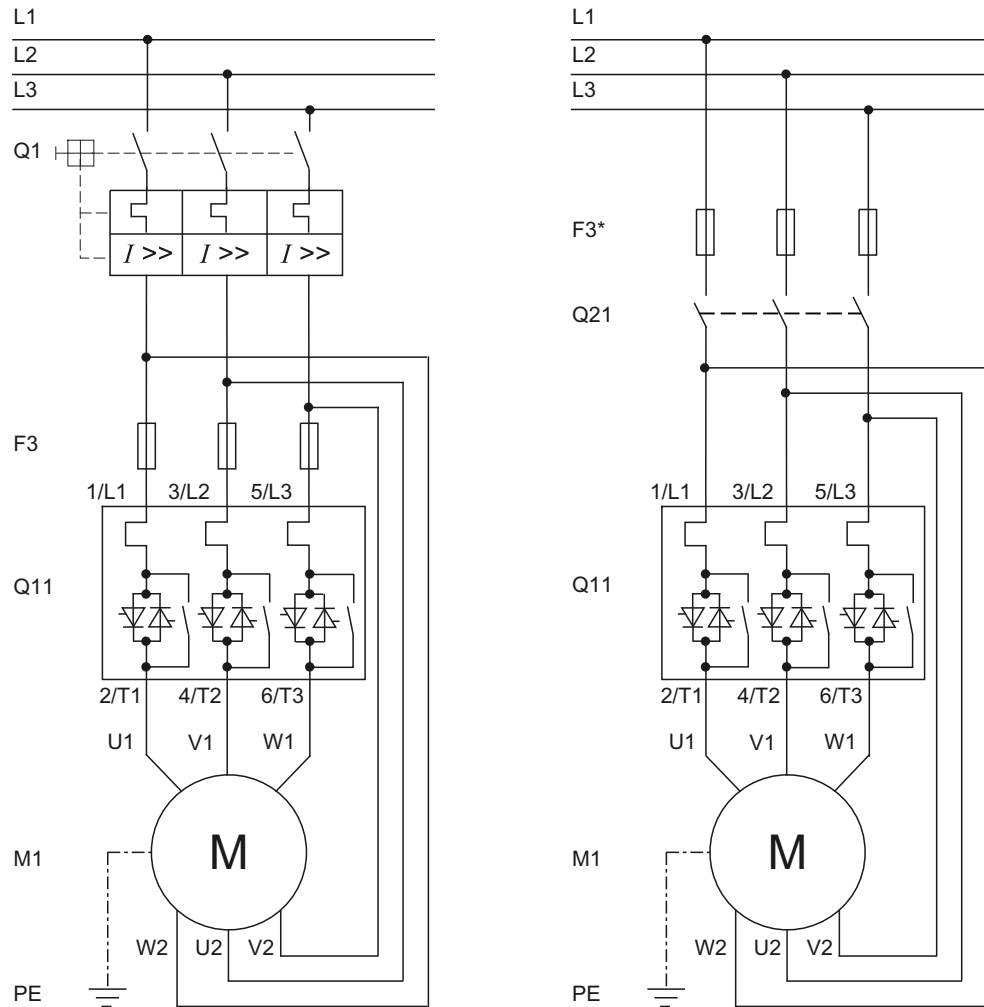

- Q1 Motor starter protector
- F3 aR partial-range fuse for protection of semiconductors (e.g. SITOR 3NE3/4 or 3NC)
- F3* gR full-range fuse for protection of semiconductors (e.g. SITOR 3NE1)
- Q11 3RW55 or 3RW55 Failsafe soft starter
- Q21 Main or line contactor for galvanic isolation
- M1 Motor
- PE Protective conductor

Motor rotation contrary to the line phase direction

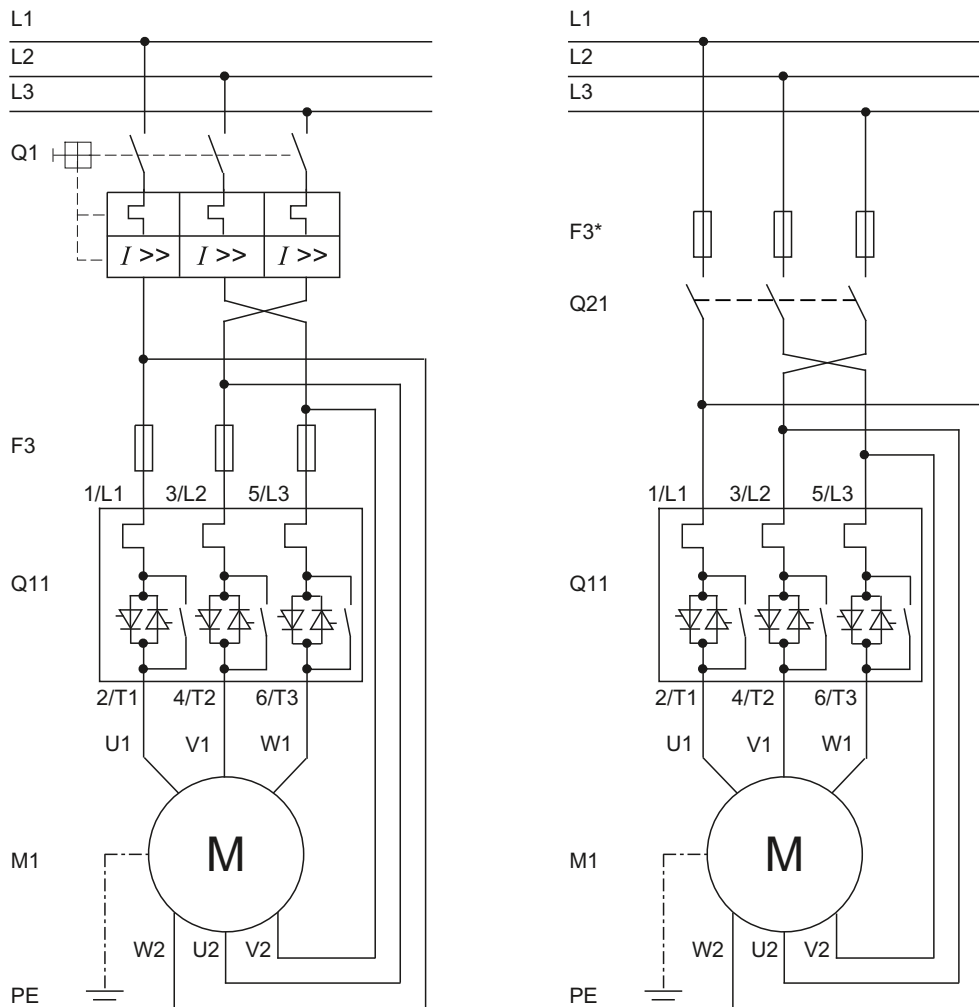

- Q1 Motor starter protector
- F3 aR partial-range fuse for protection of semiconductors (e.g. SITOR 3NE3/4 or 3NC)
- F3* gR full-range fuse for protection of semiconductors (e.g. SITOR 3NE1)
- Q11 3RW55 or 3RW55 Failsafe soft starter
- Q21 Main or line contactor for galvanic isolation
- M1 Motor
- PE Protective conductor

A.2 Control circuit connection

A.2.1 Control by PLC

Requirements

- 3RW55 or 3RW55 Failsafe soft starter (the example shows the 3RW55 soft starter with a Standard circuit)
- Parameterization required



WARNING

Automatic restart.

Can cause death or serious injury.

If a starting command is pending, a restart will be triggered automatically after the reset. This particularly applies if the motor protection has tripped. Dangerous states of the system can result.

Reset the start command (e.g. via the PLC or switch) before performing a reset.

To do this, for example, link the group error output (terminals 95 and 96) into the control.

Wiring of control circuit for control by PLC

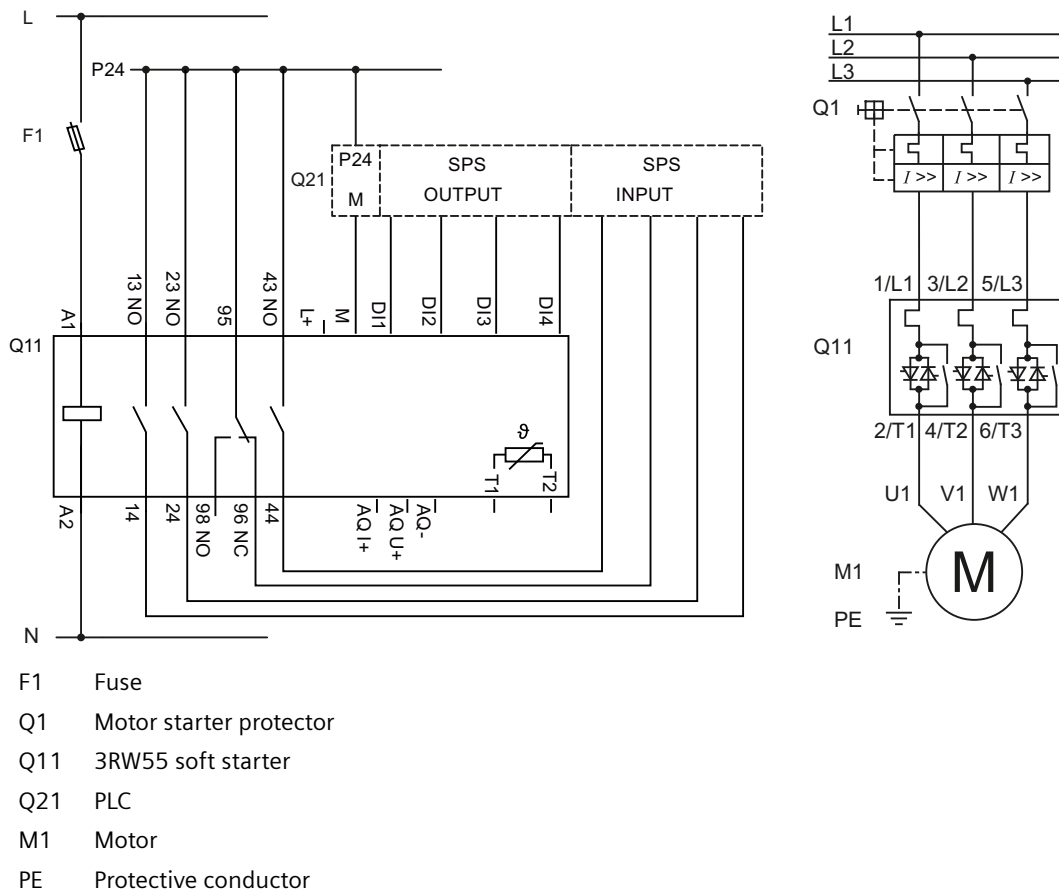

A.2.2 Control by switch

Requirements

- 3RW55 or 3RW55 Failsafe soft starter (the example shows the 3RW55 soft starter with a Standard circuit)
- Parameterization required

⚠ WARNING

Automatic restart.
Can cause death or serious injury.

If a starting command is pending, a restart will be triggered automatically after the reset. This particularly applies if the motor protection has tripped. Dangerous states of the system can result.

Reset the start command (e.g. via the PLC or switch) before performing a reset.

To do this, for example, link the group error output (terminals 95 and 96) into the control.

Wiring of control circuit for control by switch

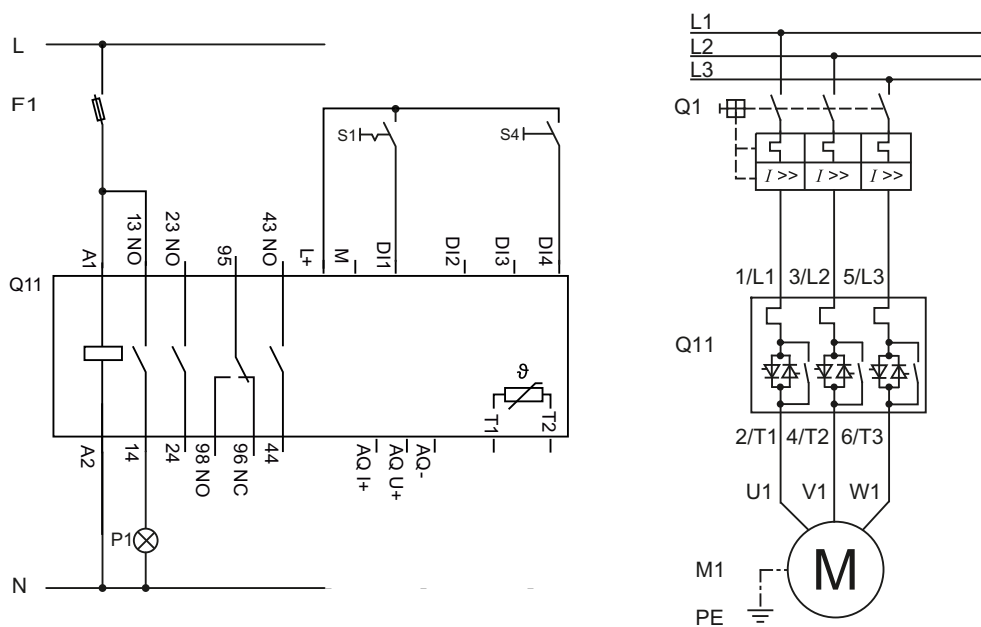

- F1 Fuse
- S1 Switch: Motor On / Off
- S4 Pushbutton: Reset
- Q1 Motor starter protector
- Q11 3RW55 soft starter
- P1 Indicator light
- M1 Motor
- PE Protective conductor

A.2.3 Actuation of a line contactor

Requirements

- 3RW55 soft starter
- Parameterization required

 **WARNING**

**Automatic restart.
Can cause death or serious injury.**

If a starting command is pending, a restart will be triggered automatically after the reset. This particularly applies if the motor protection has tripped. Dangerous states of the system can result.

Reset the start command (e.g. via the PLC or switch) before performing a reset.

To do this, for example, link the group error output (terminals 95 and 96) into the control.

Wiring of control circuit for controlling a line contactor

The example shows the 3RW55 soft starter with a Standard circuit.

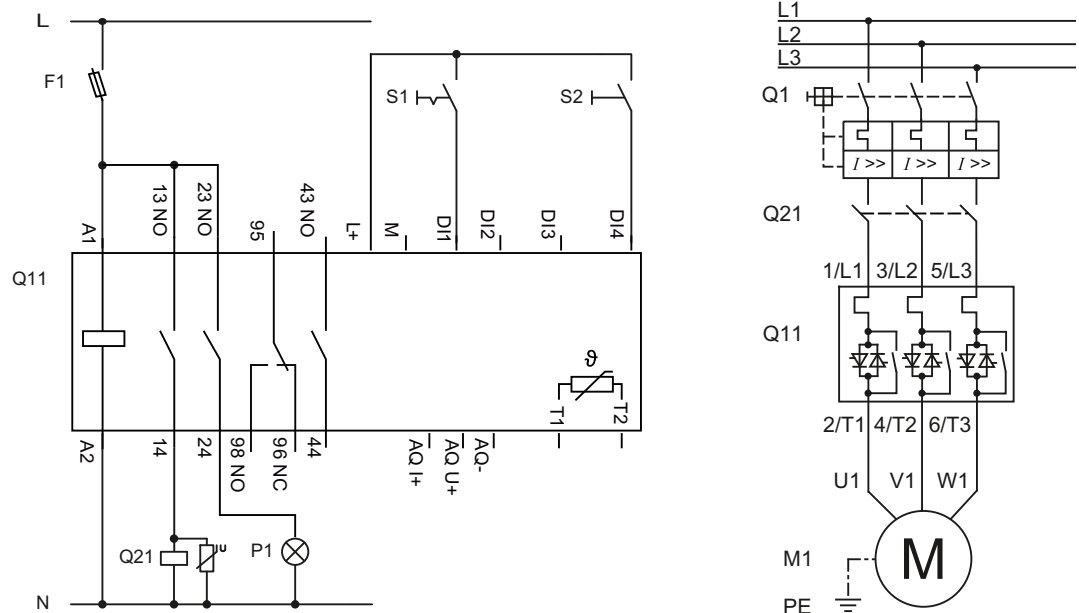

- F1 Fuse
- S1 Switch: Motor On / Off
- S2 Pushbutton: Reset
- Q1 Motor starter protector
- Q11 3RW55 soft starter
- Q21 Line contactor
- P1 Indicator light
- M1 Motor
- PE Protective conductor

A.2.4 Connecting the temperature sensor

Requirements

- 3RW55 or 3RW55 Failsafe soft starter
- Motor with temperature switch (e.g. Thermoclick) or thermistor (e.g. PTC type A)
- Parameterization required

Note

3RW55 or 3RW55 Failsafe soft starter with thermistor motor protection in Class I and Class II Hazardous Locations

Note that operation of a 3RW55 or 3RW55 Failsafe soft starter with thermistor motor protection in Class I and Class II Hazardous Locations is only possible with a thermistor (e.g. PTC Type A).

You will find further information on the operation of motors in Class I and Class II Hazardous Locations in chapters ATEX/IECEX/UKEX-certified motor overload protection (Page 18) and Temperature sensor (Page 171).

Procedure

1. Connect the temperature sensor:

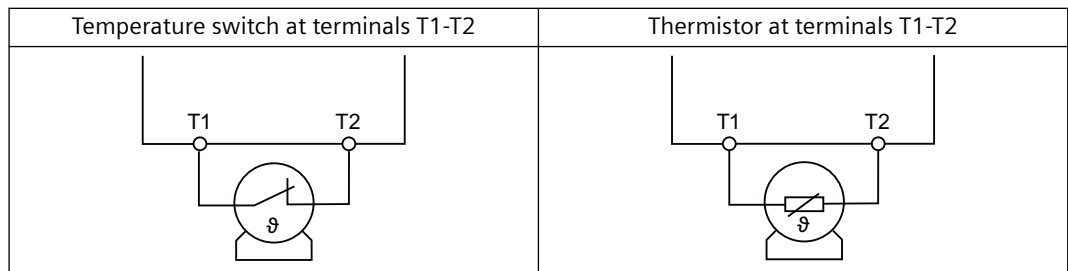

2. Parameterize the temperature sensor (Page 171).

Result

The 3RW55 and 3RW55 Failsafe soft starters monitor the motor for excessive temperature. If the temperature is exceeded, a warning is generated or the motor is switched off depending upon the parameterization. Restarting takes place after a reset.

A.2.5 Connecting the evaluation unit to the analog output

Requirements

- 3RW55 or 3RW55 Failsafe soft starter
- Evaluation unit for displaying the analog output signal
- Parameterized analog output (Page 204)

Procedure

Connect the evaluation unit:

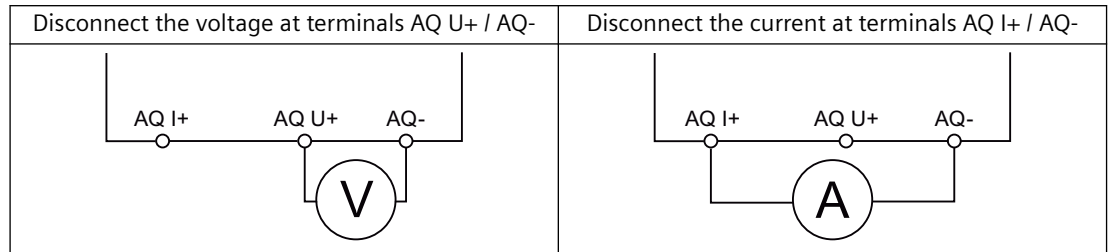

Result

The specified measured value is shown on the evaluation unit via the analog output.

A.3 Special applications

A.3.1 3RW55 and 3RW55 Failsafe soft starters in Ex operation

A.3.1.1 Type of motor connection "Standard" (inline) in Ex operation

Requirements

- 3RW55 or 3RW55 Failsafe soft starter (the example shows the 3RW55 soft starter)
- Parameterization required

 **DANGER**

**Loss of certified motor overload protection according to ATEX/IECEX/UKEX.
Can cause death or serious injury.**

Note that operation of a 3RW55 soft starter in the motor connection type "Standard" without implementing one of the two following remedial measures for the following line voltages results in loss of certified motor overload protection according to ATEX/IECEX/UKEX (does not apply to 3RW55 Failsafe soft starters):

- Soft starter 200 - 480 V: for line voltage > 440 V (+10%)
- Soft starter 200 - 600 V: for line voltage > 500 V (+10%)
- Soft starter 200 - 690 V: for line voltage > 560 V (+10%)

Depending on the circuit design, choose one of the following possibilities for ensuring certified motor overload protection according to ATEX/IECEX/UKEX:

- Use an additional line contactor in the main circuit.
Connect the line contactor at outputs 95, 96 and 98 (output 3).
- For a motor feeder configuration with a circuit breaker, use an additional undervoltage trip unit.
Connect the undervoltage trip unit at outputs 95, 96 and 98 (output 3).
You will find more information in chapter Connecting (Page 73).

Wiring for Type of motor connection "Standard" (inline) in Ex operation with additional line contactor

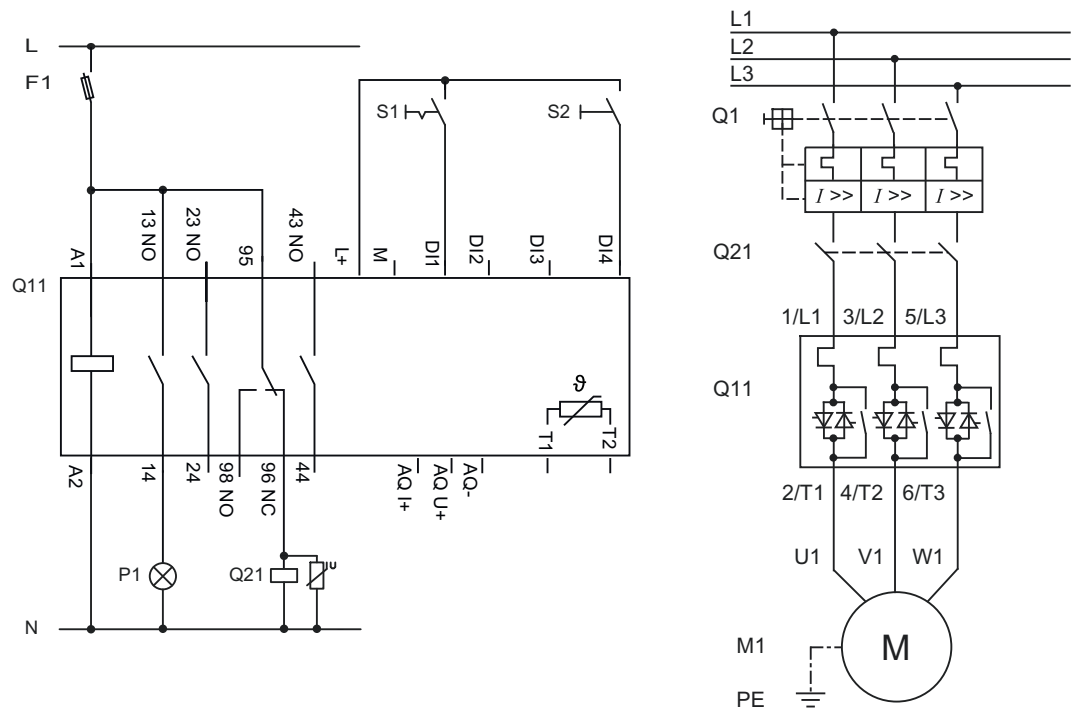

- F1 Fuse
- S1 Switch: Motor On / Off
- S2 Pushbutton: Reset
- Q1 Motor starter protector
- Q11 3RW55 soft starter
- Q21 Line contactor
- P1 Indicator light
- M1 Motor
- PE Protective conductor

A.3.1.2 Type of motor connection "inside delta" in Ex operation

Requirements

- 3RW55 or 3RW55 Failsafe soft starter (the examples show the 3RW55 soft starter)
- Parameterization required

 **DANGER**

**Loss of certified motor overload protection according to ATEX/IECEX/UKEX.
Can cause death or serious injury.**

Note that operation of a 3RW55 or 3RW55 Failsafe soft starter with motor connection type "Inside-delta" without implementing one of the two following remedial measures results in loss of certified motor overload protection according to ATEX/IECEX/UKEX:

Depending on the circuit design, choose one of the following possibilities for ensuring certified motor overload protection according to ATEX/IECEX/UKEX:

- Use an additional line contactor in the main circuit (in the supply cable or in the delta connection).
Connect the line contactor at outputs 95, 96 and 98 (output 3).
- For a motor feeder configuration with a circuit breaker, use an additional undervoltage trip unit.
Connect the undervoltage trip unit at outputs 95, 96 and 98 (output 3).
You will find more information in chapter Connecting (Page 73).

Wiring for the inside-delta circuit in Ex operation with additional line contactor in the delta

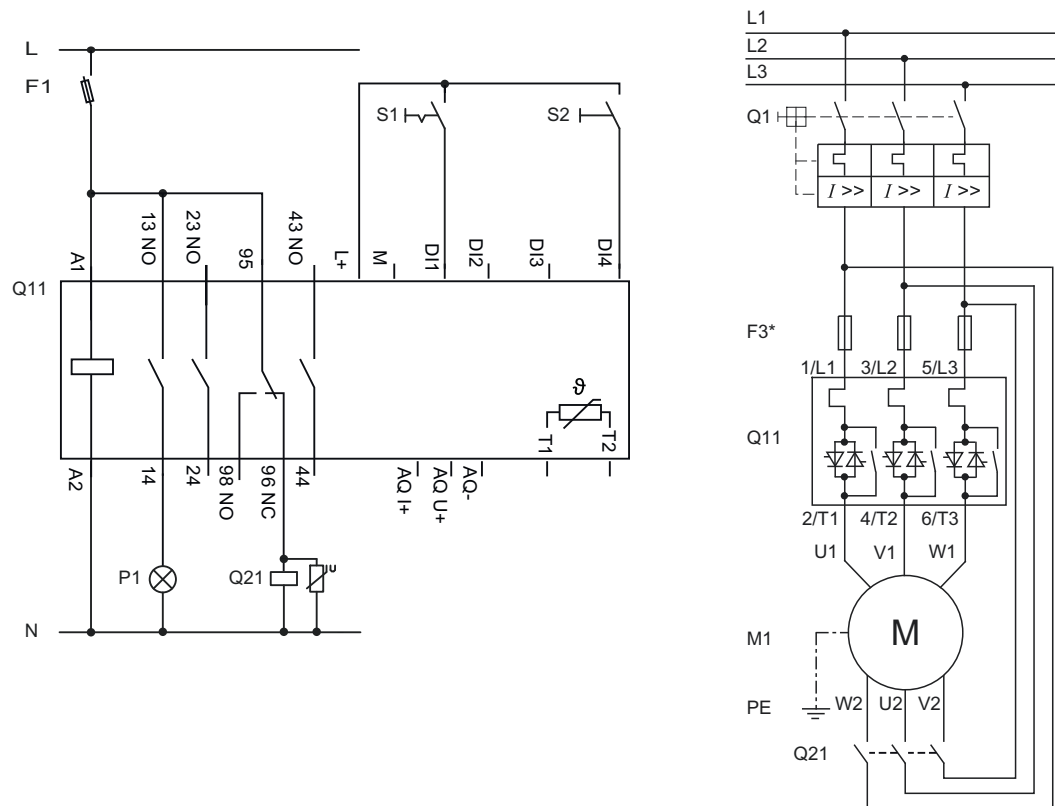

- F1 Fuse
- S1 Switch: Motor On / Off
- S2 Pushbutton: Reset
- Q1 Motor starter protector
- Q11 3RW55 soft starter
- Q21 Line contactor
- P1 Indicator light
- M1 Motor
- PE Protective conductor
- F3* aR partial-range fuse for protection of semiconductors, e.g. SITOR 3NE3/4 or 3NC (optional)

A.3.2 3RW55 soft starter in standard (inline) circuit and stopping function DC braking with one braking contactor

⚠ WARNING

**Automatic restart.
Can cause death or serious injury.**

If a starting command is pending, a restart will be triggered automatically after the reset. This particularly applies if the motor protection has tripped. Dangerous states of the system can result.

Reset the start command (e.g. via the PLC or switch) before performing a reset.

To do this, for example, link the group error output (terminals 95 and 96) into the control.

Use the "DC braking with external braking contactor" function if applications with larger mass inertias (centrifugal masses) have to be stopped ($J_{load} \leq 5 \times J_{motor}$).

If you select the stopping function "DC braking with external braking contactor", you additionally require a braking contactor. Set the output 1 to "DC braking contactor". If you select the stopping function "Dynamic DC braking without contactor", you do not require a braking contactor.

You will find further information in chapter DC braking with external braking contactors (Page 156).

Requirements

- 3RW55 soft starter
- Parameterization required
- The 3RW55 soft starter used meets the requirements of the following table:

Size	Article number of the 3RW55 soft starter	Number of required external braking contactors up to 400 V	Number of required external braking contactors higher than 400 V
Size 1	3RW551-.....	1 or 2	2
Size 2	3RW5521-..... 3RW5524-.....		

Wiring for 3RW55 soft starter in standard (inline) circuit and stopping function DC braking with one braking contactor

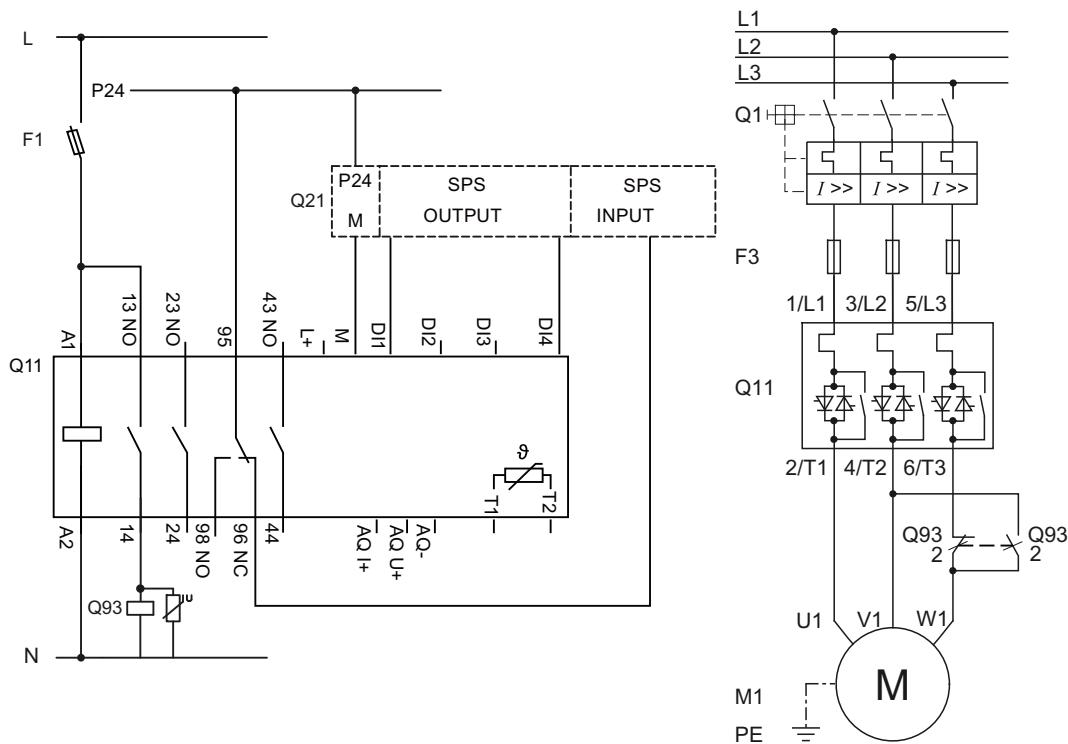

- F1 Fuse
- F3 Fuse
- Q1 Motor starter protector
- Q11 3RW55 soft starter
- Q21 PLC
- Q93 Braking contactor
- M1 Motor
- PE Protective conductor

A.3.3 3RW55 soft starter in standard (inline) circuit and stopping function DC braking with 2 braking contactors

⚠ WARNING

**Automatic restart.
Can cause death or serious injury.**

If a starting command is pending, a restart will be triggered automatically after the reset. This particularly applies if the motor protection has tripped. Dangerous states of the system can result.

Reset the start command (e.g. via the PLC or switch) before performing a reset.

To do this, for example, link the group error output (terminals 95 and 96) into the control.

Use the "DC braking with external braking contactor" function if applications with larger mass inertias (centrifugal masses) have to be stopped ($J_{load} \leq 5 \times J_{motor}$).

If you select the stopping function "DC braking with external braking contactor", you additionally require 2 braking contactors. Set the output 1 to "DC braking contactor". If you select the stopping function "Dynamic DC braking without contactor", you do not require a braking contactor.

You will find further information in chapter DC braking with external braking contactors (Page 156)

Requirements

- 3RW55 soft starter
- Parameterization required
- The 3RW55 soft starter used meets the requirements of the following table:

Size	Article number of the 3RW55 soft starter	Number of required external braking contactors up to 400 V	Number of required external braking contactors higher than 400 V
Size 1	3RW551.-.....	1 or 2	2
Size 2	3RW5521.-.....		
	3RW5524.-.....	2	
	3RW5525.-.....		
	3RW5526.-.....		
	3RW5527.-.....		
Size 3	3RW553.-.....		
Size 4	3RW554.-.....		
Size 5	3RW555.-.....		

Wiring for 3RW55 soft starter in standard (inline) circuit and stopping function DC braking with 2 braking contactors

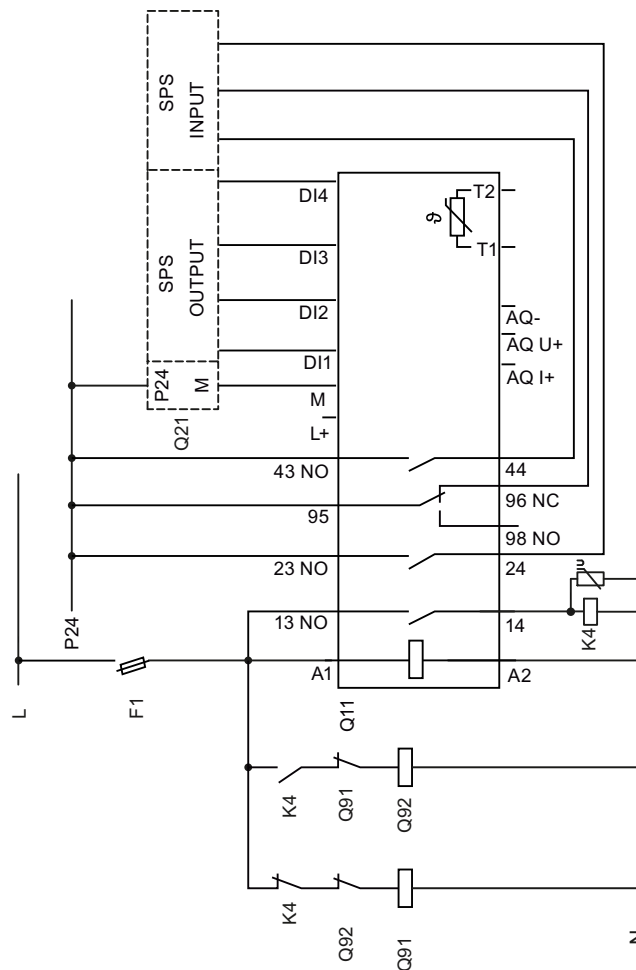
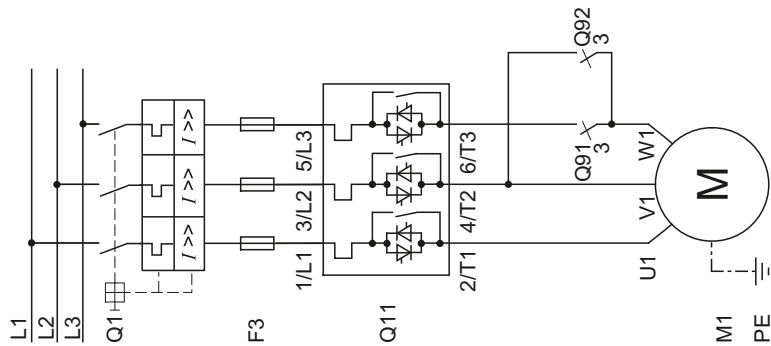

- F1 Fuse
- F3 Fuse
- K4 Auxiliary relay K4, e.g.:
LZS: RT4A4T30 (AC 230 V rated control supply voltage),
LZS: RT4A4S15 (AC 115 V rated control supply voltage)
- Q1 Motor starter protector

Q11	3RW55 soft starter
Q21	PLC
Q91	Braking contactor
Q92	Braking contactor
M1	Motor
PE	Protective conductor

A.3.4 3RW55 soft starter in standard (inline) circuit with soft starting, soft stopping and the additional function "Creep speed"

Note

Do not use the "Creep speed" function in continuous operation. The motor can heat up impermissibly in continuous operation at Creep speed.

Requirements

- 3RW55 soft starter
- Parameterization required

You will find further information in chapter Creep speed (Page 174).

Procedure

1. Set the function of the digital inputs:
 - D11 Motor CW with PS1
 - D12: Motor CCW with PS1
 - D13: Creep speed
 - D14: Reset (factory setting)
2. Set the creep speed parameters in parameter set 1.

Wiring for 3RW55 soft starter in standard (inline) circuit with soft starting, soft stopping and the additional function "Creep speed" in both directions of rotation with one parameter set

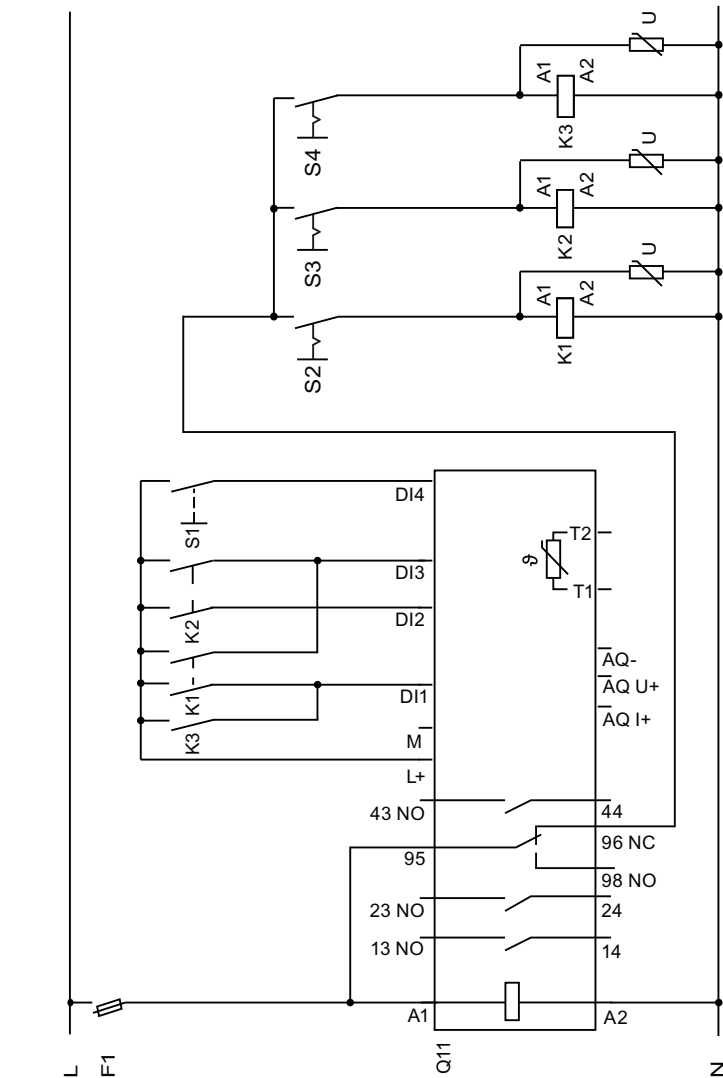
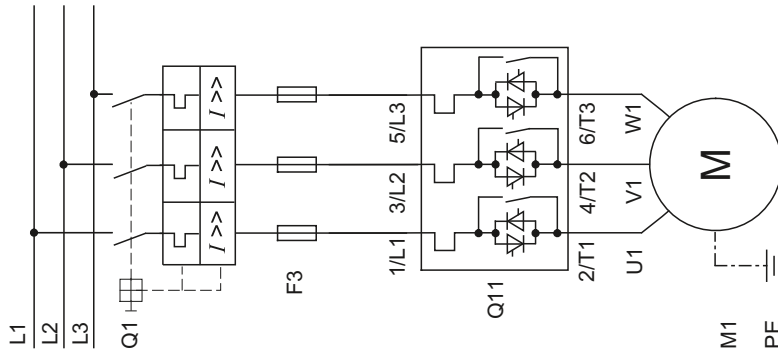

F1 Fuse
F3 Fuse

K1	Contactory relay
K2	Contactory relay
K3	Contactory relay
S1	Pushbutton: Reset
S2	Switch: Start slowly CW
S3	Switch: Start slowly CCW
S4	Switch: Start CW soft start
Q1	Motor starter protector
Q11	3RW55 soft starter
M1	Motor
PE	Protective conductor

A.3.5 Control via fieldbus with switchover to manual local operation

Requirements

- 3RW55 or 3RW55 Failsafe soft starter (the example shows the 3RW55 soft starter)
- Parameterization required
- 3RW55 or 3RW55 Failsafe soft starter with an additional 3RW5 communication module connected via fieldbus
You will find further information in the manual for the 3RW5 communication module in question.

WARNING

Automatic restart.

Can cause death or serious injury.

If a starting command is pending, a restart will be triggered automatically after the reset. This particularly applies if the motor protection has tripped. Dangerous states of the system can result.

Reset the start command (e.g. via the PLC or switch) before performing a reset.

To do this, for example, link the group error output (terminals 95 and 96) into the control.

Wiring for control via fieldbus with switchover to manual local operation

The example shows the 3RW55 soft starter with a Standard circuit.

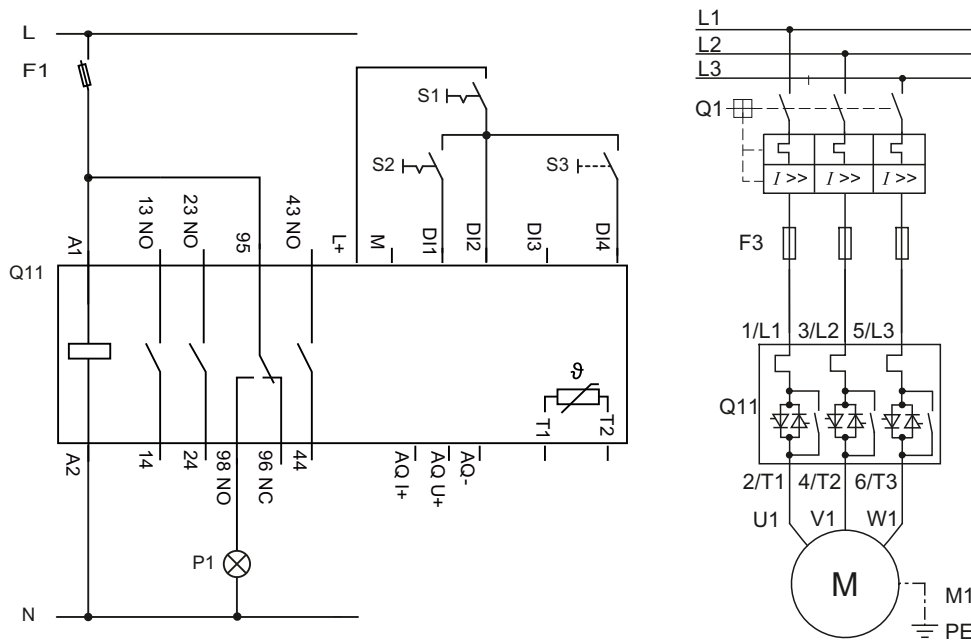

- F1 Fuse
- F3 Fuse
- S1 Switch: Manual mode local
- S2 Switch: Start / stop (manual mode local)
- S3 Switch: Reset (manual mode local)
- P1 Indicator light
- Q1 Motor starter protector
- Q11 3RW55 soft starter via fieldbus (e.g. PROFINET)
- M1 Motor
- PE Protective conductor

A.3.6 Pump cleaning function

A.3.6.1 Pump cleaning function with creep speed

Requirements

- 3RW55 soft starter
- Parameterization required

You will find further information in chapter Pump cleaning function (Page 184) and on the Internet under the FAQs (<https://support.industry.siemens.com/cs/ww/en/view/109761112>).

<p>⚠ WARNING</p> <p>Automatic restart. Can cause death or serious injury.</p> <p>If a starting command is pending, a restart will be triggered automatically after the reset. This particularly applies if the motor protection has tripped. Dangerous states of the system can result.</p> <p>Reset the start command (e.g. via the PLC or switch) before performing a reset.</p> <p>To do this, for example, link the group error output (terminals 95 and 96) into the control.</p>
--

Wiring of the control circuit with pump cleaning function with creep speed

The example shows the 3RW55 soft starter with a Standard circuit.

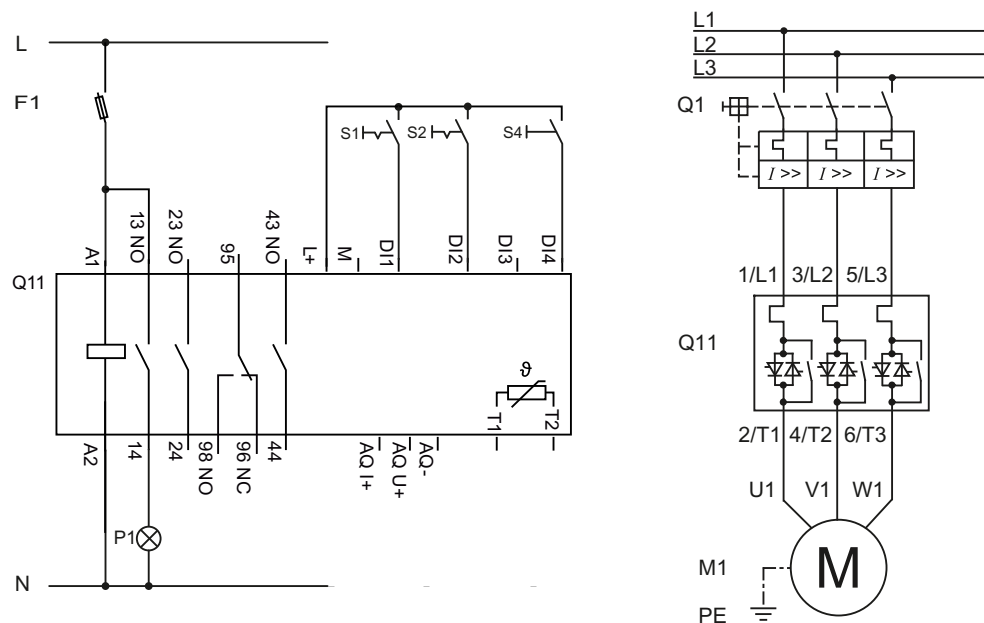

- F1 Fuse
- S1 Switch: Motor On / Off
- S2 Activate pump cleaning
- S4 Pushbutton: Reset
- Q1 Motor starter protector
- Q11 3RW55 soft starter
- P1 Indicator light
- M1 Motor
- PE Protective conductor

A.3.6.2 Pump cleaning function with reversing contactor

Requirements

- 3RW55 or 3RW55 Failsafe soft starter (the example shows the 3RW55 soft starter with a Standard circuit)
- Parameterization required

You will find further information in chapter Pump cleaning function (Page 184) and on the Internet under the FAQs (<https://support.industry.siemens.com/cs/ww/en/view/109761112>).



WARNING

Automatic restart.

Can cause death or serious injury.

If a starting command is pending, a restart will be triggered automatically after the reset. This particularly applies if the motor protection has tripped. Dangerous states of the system can result.

Reset the start command (e.g. via the PLC or switch) before performing a reset.

To do this, for example, link the group error output (terminals 95 and 96) into the control.

Wiring of the control circuit with pump cleaning function with reversing switching element

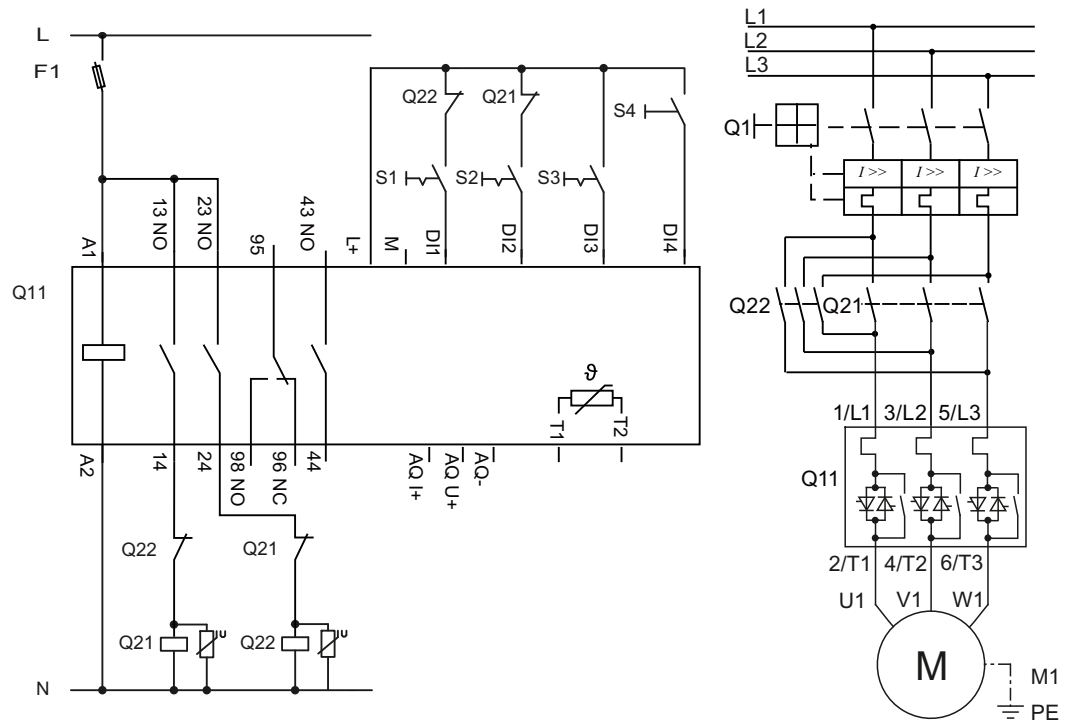

- F1 Fuse
- S1 Switch: Motor On / Off CW
- S2 Switch: Motor On / Off CCW
- S3 Activate pump cleaning
- S4 Pushbutton: Reset
- Q1 Motor starter protector
- Q11 3RW55 soft starter
- Q21 Reversing switching element - right
- Q22 Reversing switching element - left
- M1 Motor
- PE Protective conductor

A.3.7 Reversing duty

Requirements

- 3RW55 or 3RW55 Failsafe soft starter (the example shows the 3RW55 soft starter)
- Parameterization required:
 - The input action DI1 is set to "Motor CW".
 - The input action DI2 is set to "Motor CCW".
 - The input action DI3 is set to "Manual operation local".
 - The output action DO1 is set to "Reversing switching element - right".
 - The output action DO21 is set to "Reversing switching element - left".

 **WARNING**

**Automatic restart.
Can cause death or serious injury.**

If a starting command is pending, a restart will be triggered automatically after the reset. This particularly applies if the motor protection has tripped. Dangerous states of the system can result.

Reset the start command (e.g. via the PLC or switch) before performing a reset.

To do this, for example, link the group error output (terminals 95 and 96) into the control.

Wiring for reversing duty:

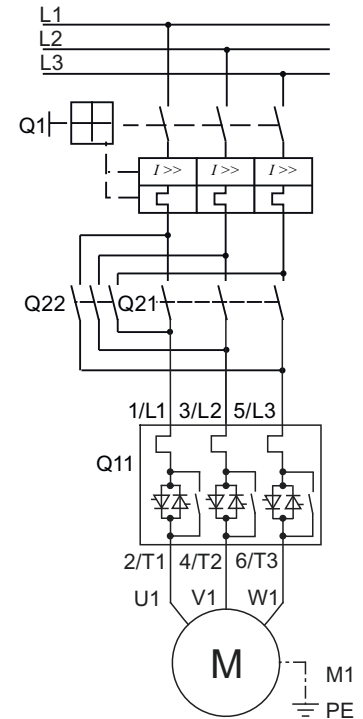
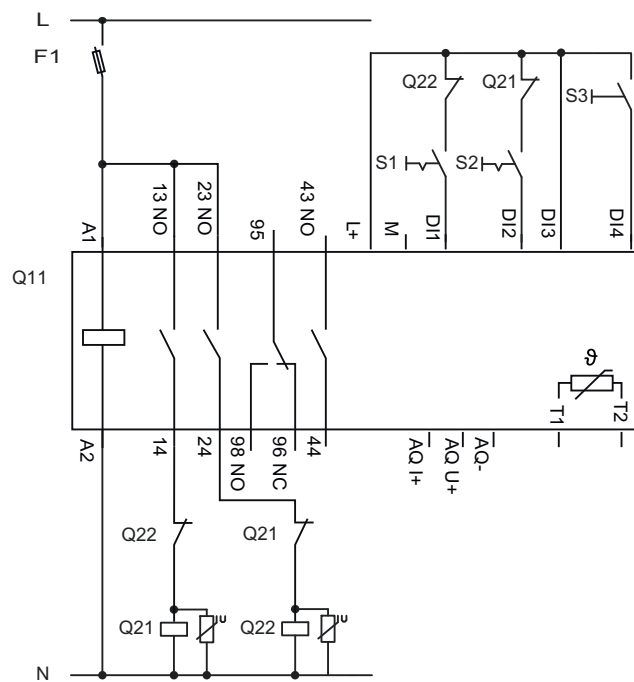

- F1 Fuse
- S1 Switch: Motor On / Off CW
- S2 Switch: Motor On / Off CCW
- S3 Pushbutton: Reset
- Q1 Motor starter protector
- Q11 3RW55 soft starter
- Q21 Reversing switching element - right
- Q22 Reversing switching element - left
- M1 Motor
- PE Protective conductor

A.3.8 3RW55 soft starter for serial starting with 3 parameter sets

Requirements

- 3RW55 soft starter
- Parameterization required

 **WARNING**

Automatic restart.

Can cause death or serious injury.

If a starting command is pending, a restart will be triggered automatically after the reset. This particularly applies if the motor protection has tripped. Dangerous states of the system can result.

Reset the start command (e.g. via the PLC or switch) before performing a reset.

To do this, for example, link the group error output (terminals 95 and 96) into the control.

Note

Set the stopping mode "Coasting down" on the 3RW55 soft starter.

Make sure that the input actions are parameterized each with its own parameter set:

- "Motor CW with PS1" for input DI1
- "Motor CW with PS2" for input DI2
- "Motor CW with PS3" for input DI3
- "Reset" for input DI4 (optional)

Make sure that the output actions are parameterized as "Operation / Bypass".

Note

In the case of increased operating sequences, set the dimensions for the 3RW55 soft starters to at least one capacity level higher than the highest connected motor output.

Wiring for 3RW55 soft starter for serial starting with 3 parameter sets - main circuit

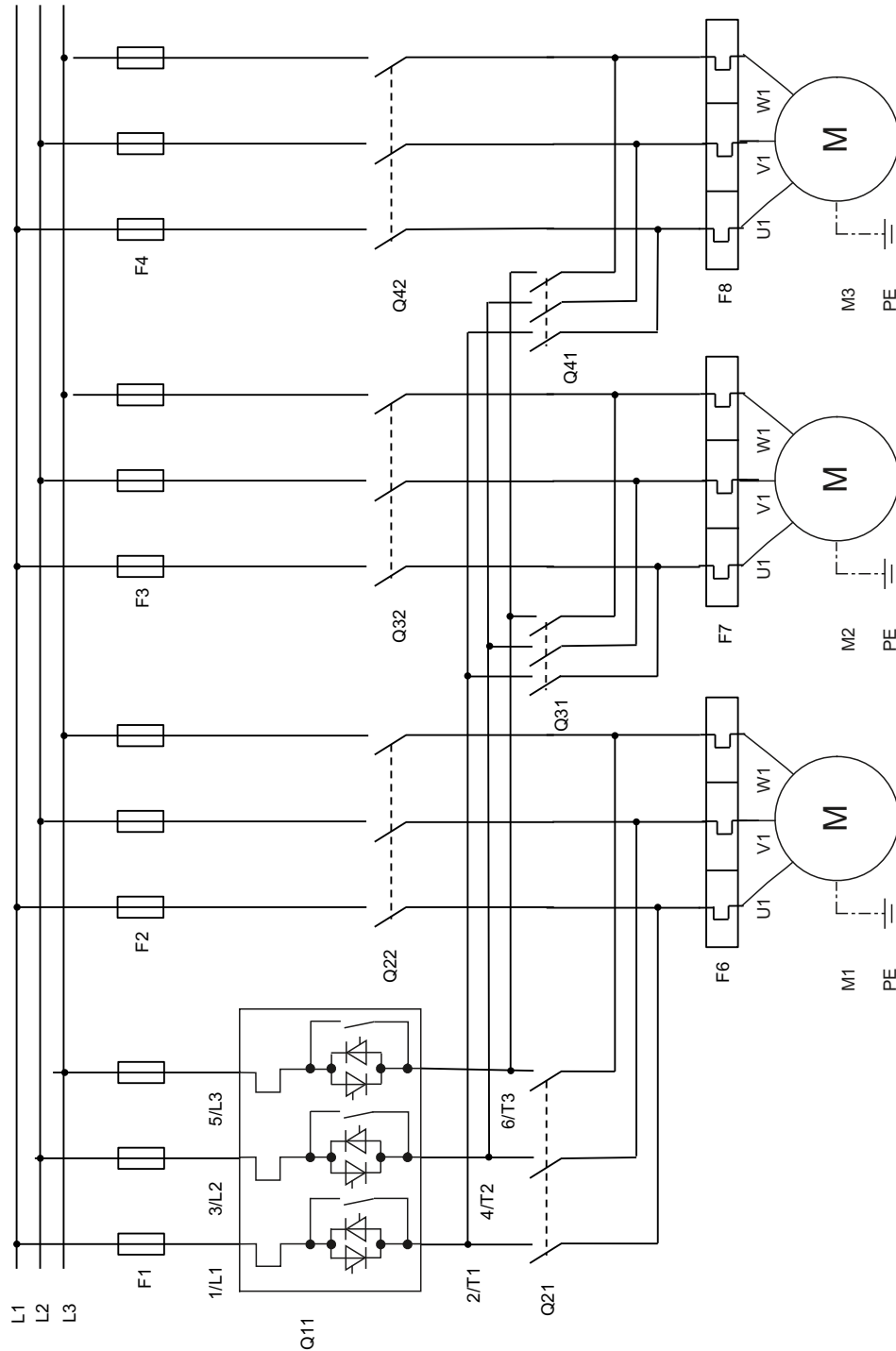

- F1 Fuse
- F2 Fuse, motor 1
- F3 Fuse, motor 2
- F4 Fuse, motor 3

A.3 Special applications

F6	Overload relay, motor 1
F7	Overload relay, motor 2
F8	Overload relay, motor 3
Q11	3RW55 soft starter
Q21	Starting contactor, motor 1
Q22	Line contactor, motor 1
Q31	Starting contactor, motor 2
Q32	Line contactor, motor 2
Q41	Starting contactor, motor 3
Q42	Line contactor, motor 3
M1	Motor 1
M2	Motor 2
M3	Motor 3
PE	Protective conductor

Wiring for 3RW55 soft starter for serial starting with 3 parameter sets - control circuit

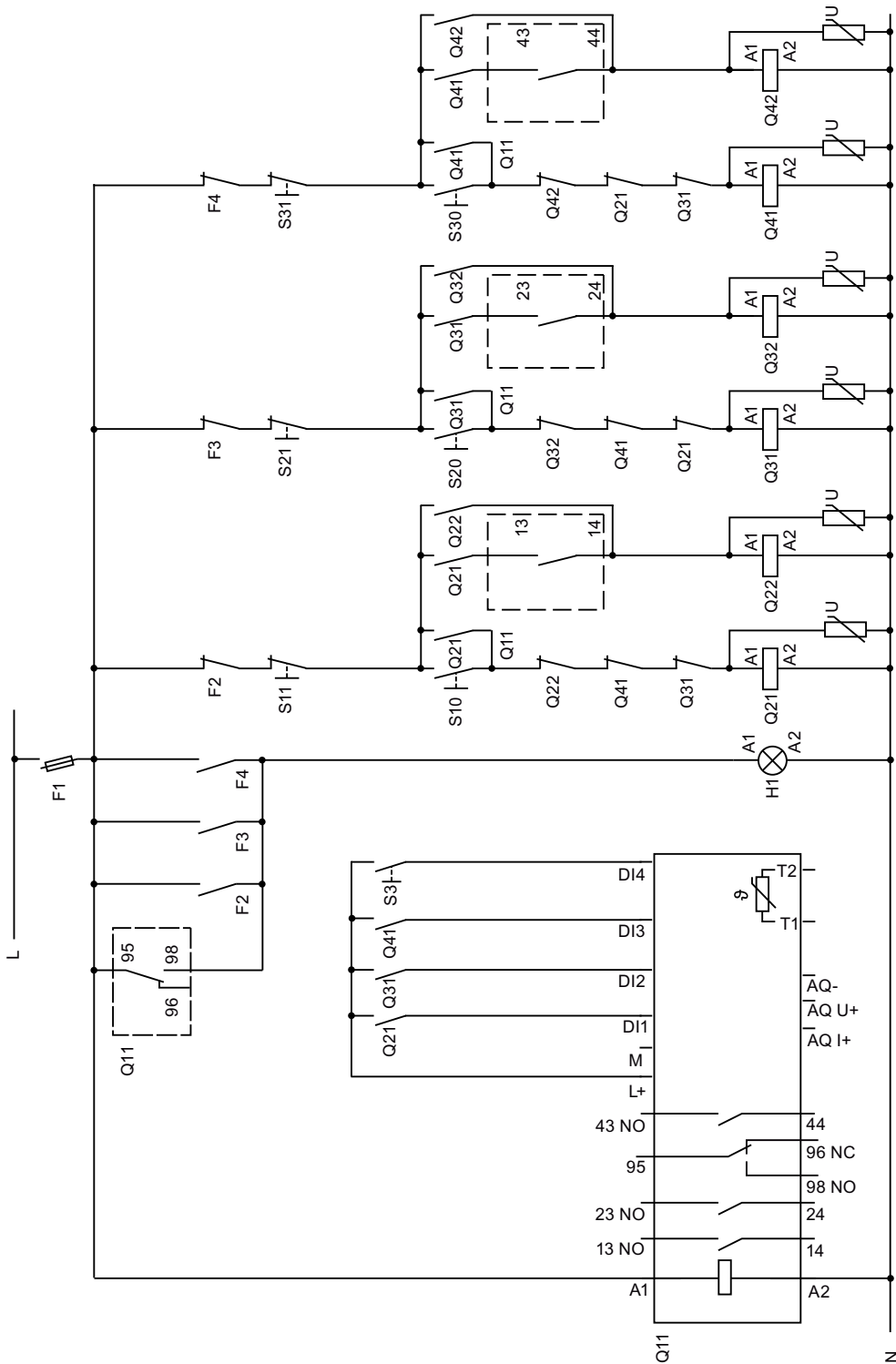

F2 Fuse
F3 Fuse

A.3 Special applications

F4	Fuse
S3	Pushbutton: Reset
S10	Pushbutton: Motor 1 Start
S11	Pushbutton: Motor 1 Stop
S20	Pushbutton: Motor 2 Start
S21	Pushbutton: Motor 2 Stop
S30	Pushbutton: Motor 3 Start
S31	Pushbutton: Motor 3 Stop
Q11	3RW55 soft starter
Q21	Starting contactor, motor 1
Q22	Line contactor, motor 1
Q31	Starting contactor, motor 2
Q32	Line contactor, motor 2
Q41	Starting contactor, motor 3
Q42	Line contactor, motor 3
H1	Indicator light

A.3.9 Soft starter for pole-changing motor with separate windings and 2 parameter sets

Requirements

- 3RW55 or 3RW55 Failsafe soft starter (the example shows the 3RW55 soft starter)
- Parameterization required

Note

The "Coasting down" stopping mode must be set on the 3RW5.

 WARNING**Automatic restart.
Can cause death or serious injury.**

If a starting command is pending, a restart will be triggered automatically after the reset. This particularly applies if the motor protection has tripped. Dangerous states of the system can result.

Reset the start command (e.g. via the PLC or switch) before performing a reset.

To do this, for example, link the group error output (terminals 95 and 96) into the control.

Wiring for soft starter for pole-changing motor with separate windings and 2 parameter sets

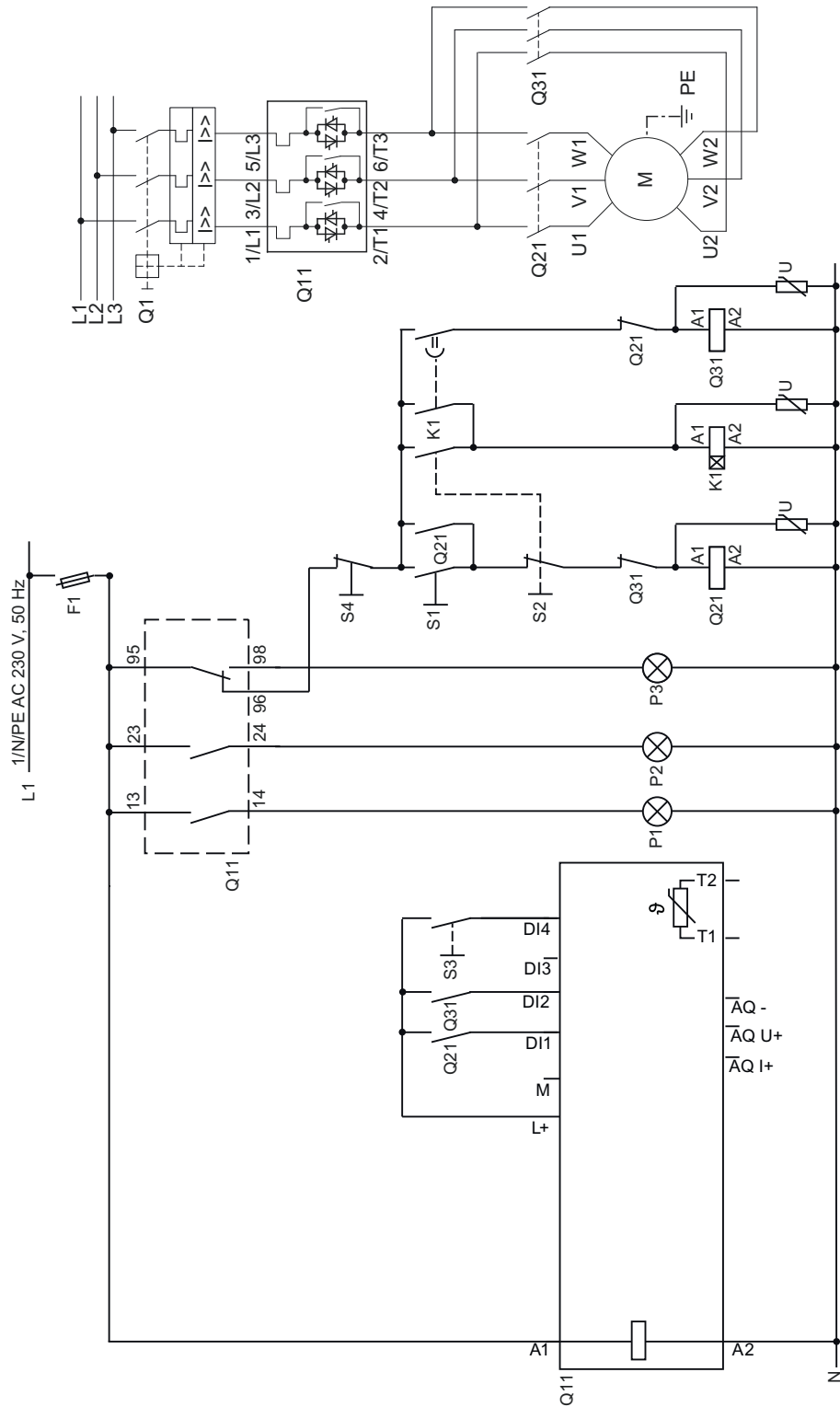

- F1 Fuse
- S1 Pushbutton: Start, low speed

S2	Pushbutton: Start, high speed
S3	Pushbutton: Reset
S4	Pushbutton: Stop motor
Q1	Motor starter protector
Q11	3RW55 soft starter
Q21	Main contactor for low speed
Q31	Main contactor for high speed
K1	Contactor relay for switching delay (response delay 500 ms)
M	Motor
PE	Protective conductor
P1	Indicator light: Motor rotates at low speed
P2	Indicator light: Motor rotates at high speed
P3	Indicator light: Error

A.3.10 3RW55 soft starter with direct-on-line starting (DOL) as emergency start

Requirements

- 3RW55 soft starter
- Parameterization required

 WARNING
Automatic restart. Can cause death or serious injury.
If a starting command is pending, a restart will be triggered automatically after the reset. This particularly applies if the motor protection has tripped. Dangerous states of the system can result.
Reset the start command (e.g. via the PLC or switch) before performing a reset.
To do this, for example, link the group error output (terminals 95 and 96) into the control.

Wiring for 3RW55 soft starter with direct-on-line starting (DOL) as emergency start

The example shows the 3RW55 soft starter with a Standard circuit.

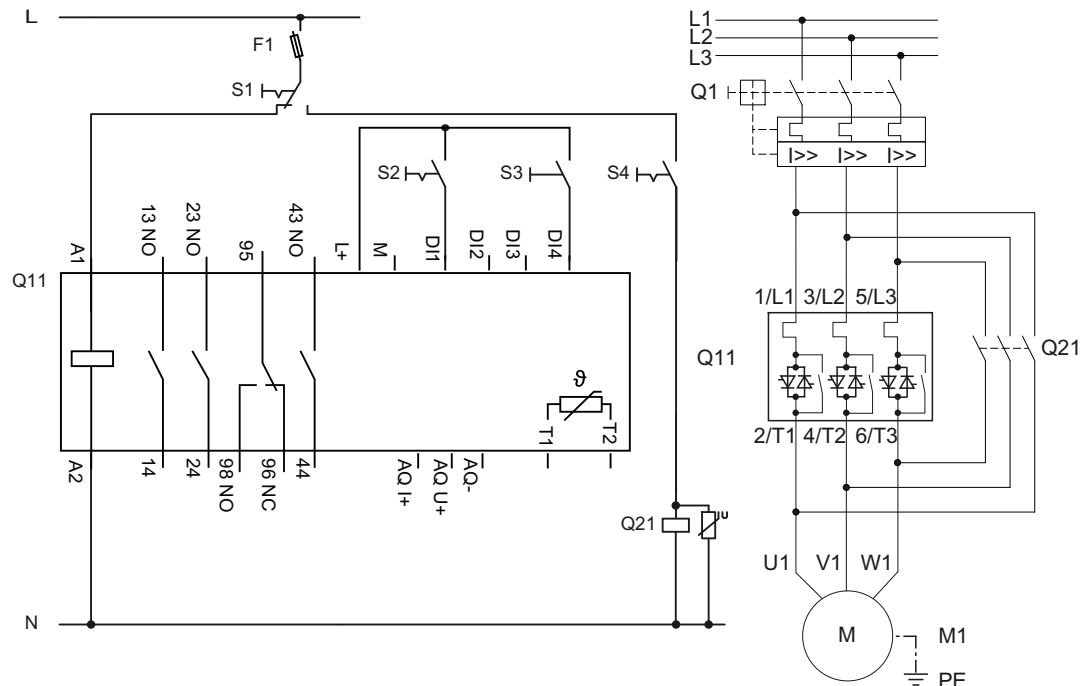

- F1 Fuse
- S1 Selector switch Soft starting / direct-on-line starting
- S2 Switch: Start / stop (3RW55 soft starter)
- S3 Pushbutton: Reset
- S4 Switch: Direct on-line starting (DOL)
- Q11 3RW55 soft starter
- Q21 Line contactor
- M1 Motor
- PE Protective conductor

A.3.11 Starting a Dahlander motor

Requirements

- ON / RUN relay output was parameterized to ON.
- No soft stop possible. Set the ramp-down time 0 s at the setting element

 **WARNING**

Automatic restart.

Can cause death or serious injury.

If a starting command is pending, a restart will be triggered automatically after the reset. This particularly applies if the motor protection has tripped. Dangerous states of the system can result.

Reset the start command (e.g. via the PLC or switch) before performing a reset.

To do this, for example, link the group error output (terminals 95 and 96) into the control.

Wiring

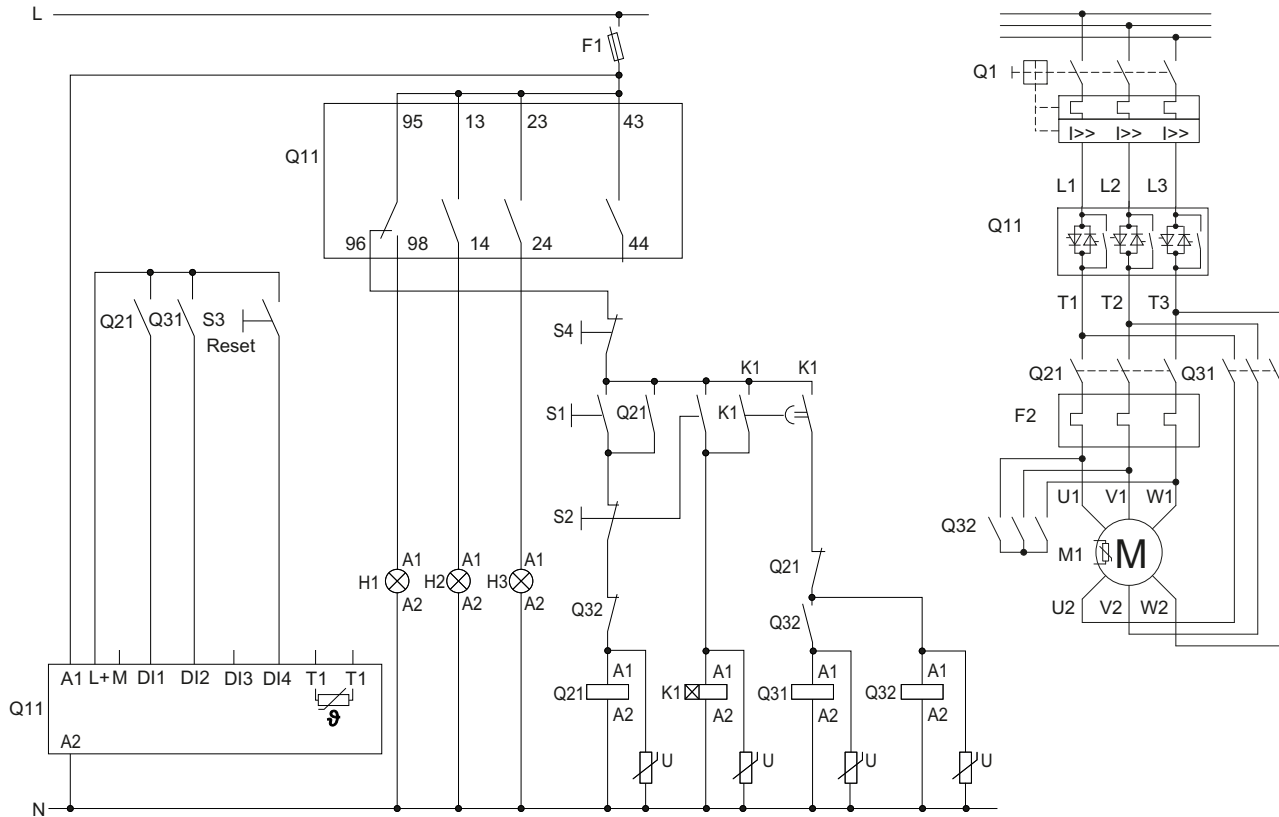

- F1 Fuse
- K1 Contactor relay for switching delay (response delay 500 ms)
- S1 Pushbutton: Start, low speed
- S2 Pushbutton: Start, high speed
- S3 Pushbutton: Reset
- S4 Pushbutton: Motor stop
- Q1 Motor starter protector
- Q11 3RW55 soft starter
- Q21 Line contactor: Low speed
- Q31 Line contactor: High speed
- Q32 Star (wye) contactor: High speed
- H1 Indicator light: Fault
- H2 Indicator light: Low motor speed
- H3 Indicator light: High speed
- M1 Motor
- DI1 Motor CW parameter data set 1
- DI2 Motor CW parameter data set 2
- DI4 Reset

A.3.12 External bypass

Requirements

- Parameter "Tripping class" is set to "CLASS OFF".
- The "Bypass operating mode" parameter (in the "Additional parameters" menu) is set to "External bypass".
- Parameter "Output action" of the output at which the external bypass contactor is connected is set to "External bypass".
- External bypass contactor
- External overload relay

NOTICE
Material damage due to overload
If an external bypass is used, the intrinsic device protection and the motor overload protection will be deactivated. This can result in damage to the soft starter or the motor due to overload.
Use an additional external overload protection to protect the soft starter and the motor from damage due to overload.

Wiring

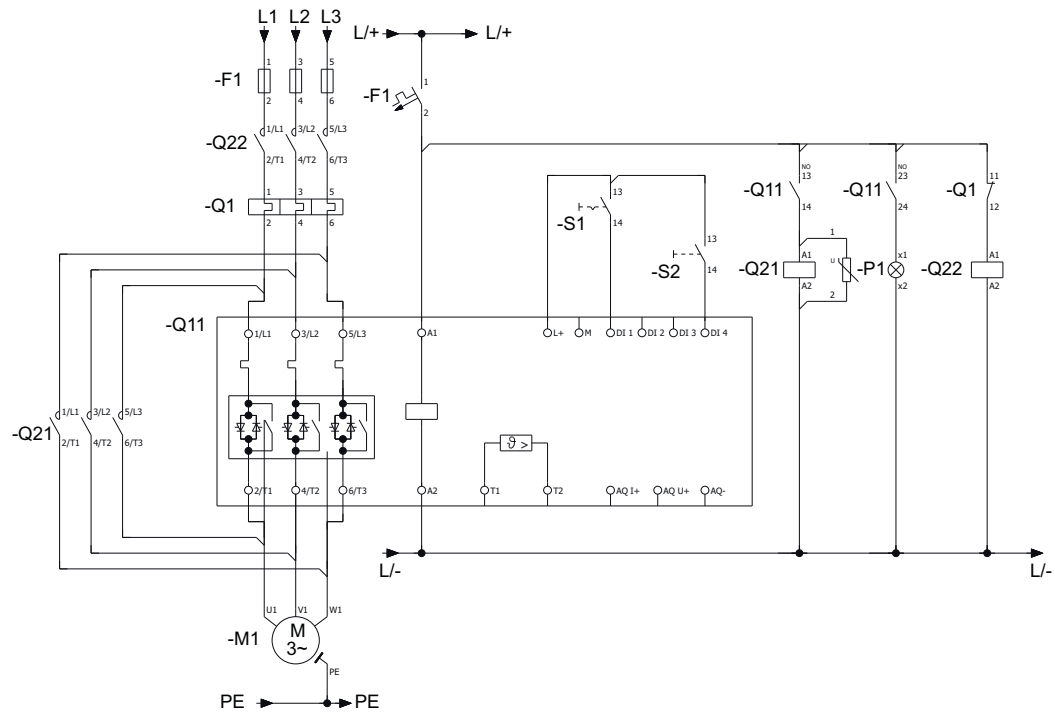

- F1 Fuse
- S1 Pushbutton: Switch: Motor On / Off
- S2 Pushbutton: Reset
- Q1 External overload relay
- Q11 3RW5 soft starter
- Q21 External bypass contactor
- Q22 Main contactor
- P1 Indicator light
- M1 Motor
- PE Protective conductor

A.3.13 EMERGENCY STOP shutdown to SIL 1 or PL c with a 3SK1 safety relay without the 3RW55 Failsafe soft starter

The 3RW55 soft starter has no effect or influence on the safety function of the application. For this reason, it is neither positively nor negatively considered in the safety application, and also does not have to be included in the calculation for proof according to the standards.

Requirements

- 3RW55 soft starter
For the 3RW55 Failsafe soft starter, refer to chapter 3RW55 Failsafe soft starter (Page 345).
- If the soft stop function is set (stopping time setting element set to > 0 s) and the EMERGENCY STOP circuit is tripped, a "Missing load" error message may be indicated on the 3RW55 soft starter. Use Reset to reset the error message.

Basic configuration

If achievement of SIL 1 according to IEC 62061 / PL c according to EN ISO 13849-1 is required, the series connection of an additional contactor with the 3RW55 soft starter, together with a suitable safety relay (e.g.: 3SK1111), is required, as well as monitoring of the contactor's auxiliary contacts.

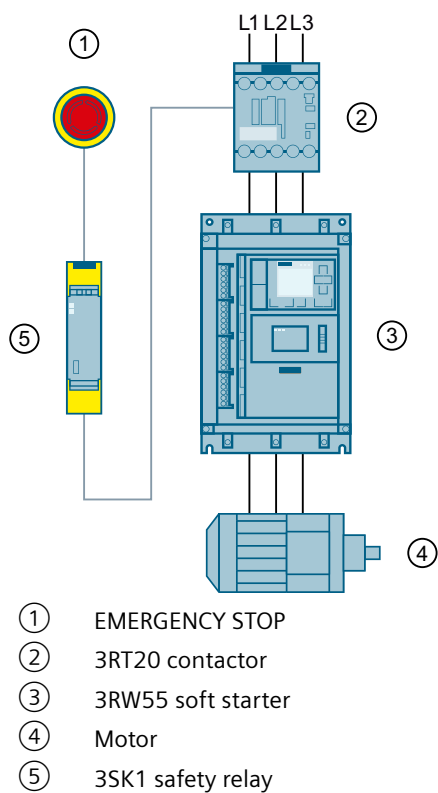

Wiring of the 3RW55 soft starter

The example shows the 3RW55 soft starter with a Standard circuit.

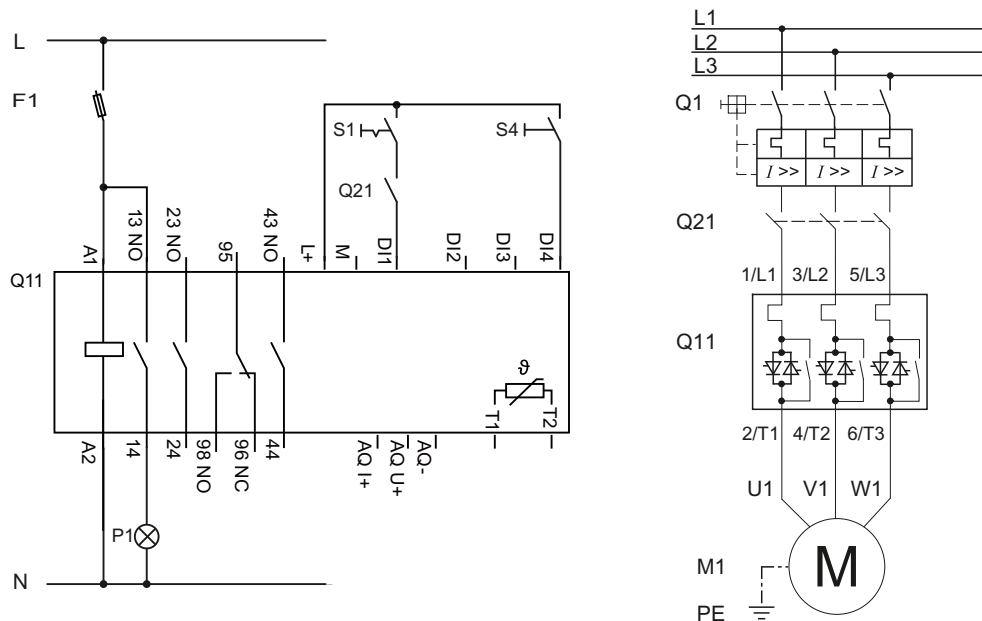

- F1 Fuse
- S1 Switch: Start/stop
- S4 Pushbutton: Reset > 4 s
- Q1 Motor starter protector
- Q11 3RW55 soft starter
- Q21 Contactor
- P1 Indicator light
- M1 Motor

⚠ WARNING

**Automatic restart.
Can cause death or serious injury.**

If a starting command is pending, a restart will be triggered automatically after the reset. This particularly applies if the motor protection has tripped. Dangerous states of the system can result.

Reset the start command (e.g. via the PLC or switch) before performing a reset.

To do this, for example, link the group error output (terminals 95 and 96) into the control.

Wiring of the 3SK1 safety relay SIL 1 with line contactor

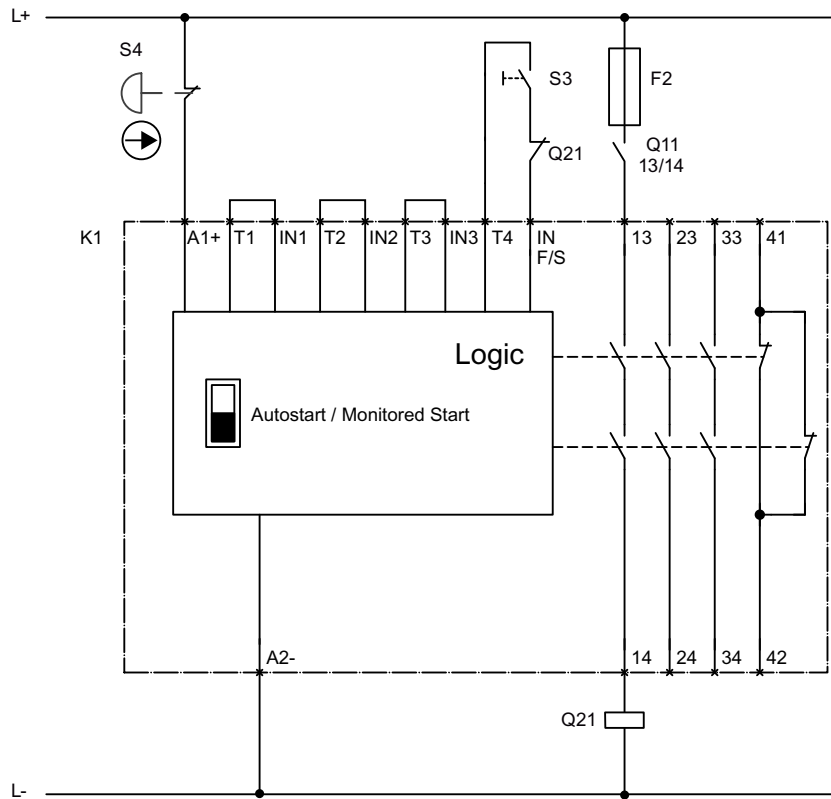

- F2 Fuse
- Q11 Line contactor
- Q21 Contactor
- S3 Start button
- S4 EMERGENCY STOP
- K1 3SK1111 safety relay

Wiring of the 3SK1 safety relay SIL 1 without line contactor

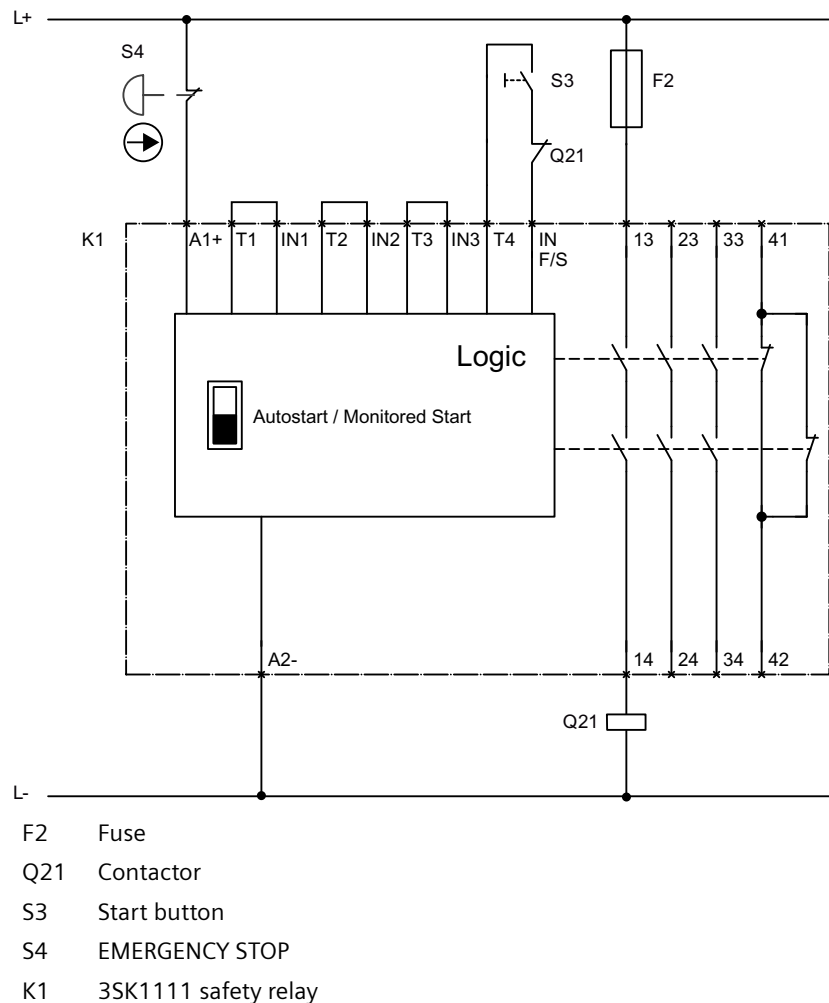

A.3.14 EMERGENCY STOP shutdown up to SIL 3 or PL e with a 3SK1 safety relay without the 3RW55 Failsafe soft starter

The 3RW55 soft starter has no effect or influence on the safety function of the application. For this reason, it is neither positively nor negatively considered in the safety application, and also does not have to be included in the calculation for proof according to the standards.

Requirements

- 3RW55 soft starter
For the 3RW55 Failsafe soft starter, refer to chapter 3RW55 Failsafe soft starter (Page 345).
- If the soft stop function is set (stopping time setting element set to > 0 s) and the EMERGENCY STOP circuit is tripped, a "Missing load" error message may be indicated on the 3RW55 soft starter. Use Reset to reset the error message.

Basic configuration

Safe shutdown up to SIL 3 according to IEC 62061 / PL e according to EN ISO 13849-1 requires the use of 2 redundant contactors and monitoring of the auxiliary contacts of both contactors. Two-channel monitoring of the EMERGENCY STOP is also required here.

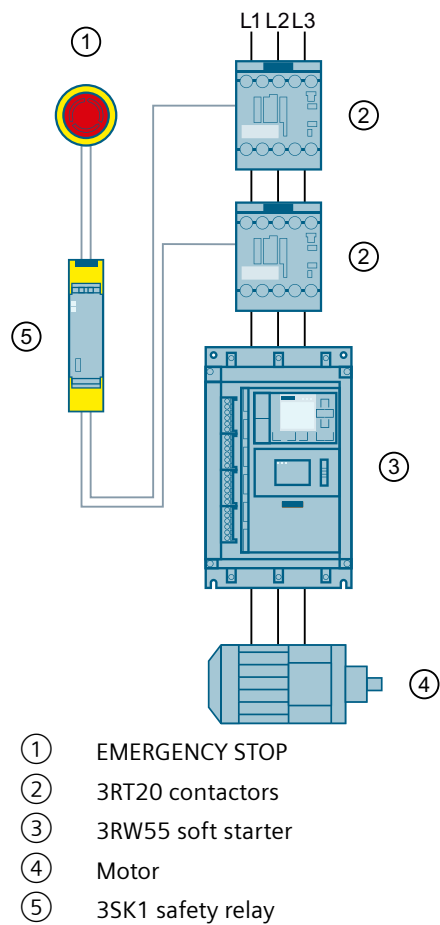

Wiring of the 3RW55 soft starter

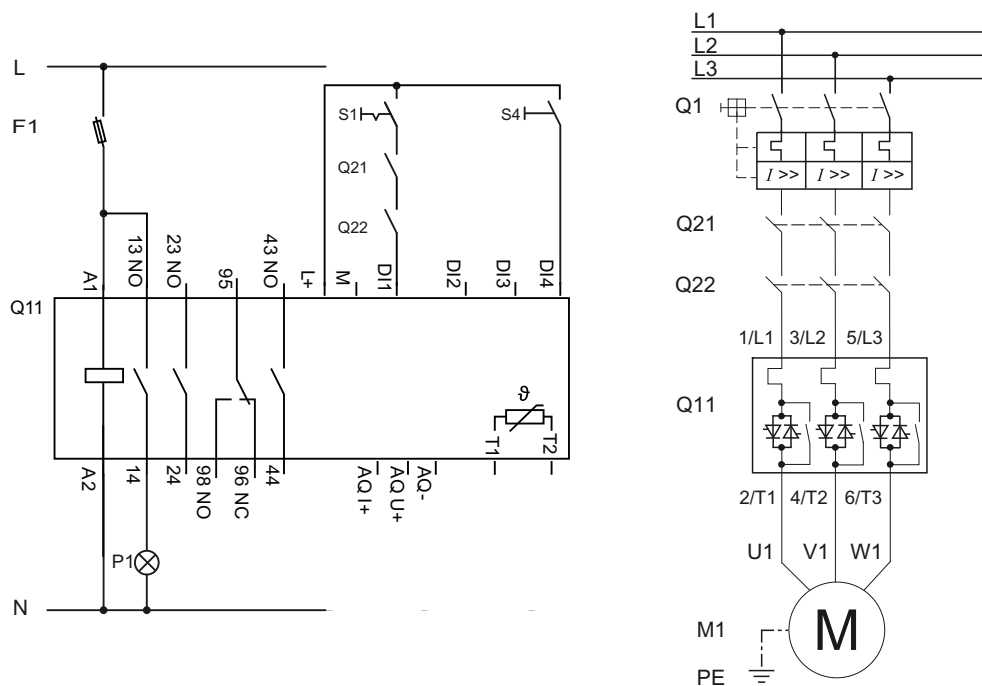

- F1 Fuse
- S1 Switch: Start/stop
- S4 Pushbutton: Reset > 4 s
- Q1 Motor starter protector
- Q11 3RW55 soft starter
- Q21 Contactor
- Q22 Contactor
- P1 Indicator light
- M1 Motor

⚠ WARNING

Automatic restart.
Can cause death or serious injury.

If a starting command is pending, a restart will be triggered automatically after the reset. This particularly applies if the motor protection has tripped. Dangerous states of the system can result.

Reset the start command (e.g. via the PLC or switch) before performing a reset.

To do this, for example, link the group error output (terminals 95 and 96) into the control.

Wiring of the 3SK1 safety relay SIL 3 with line contactor

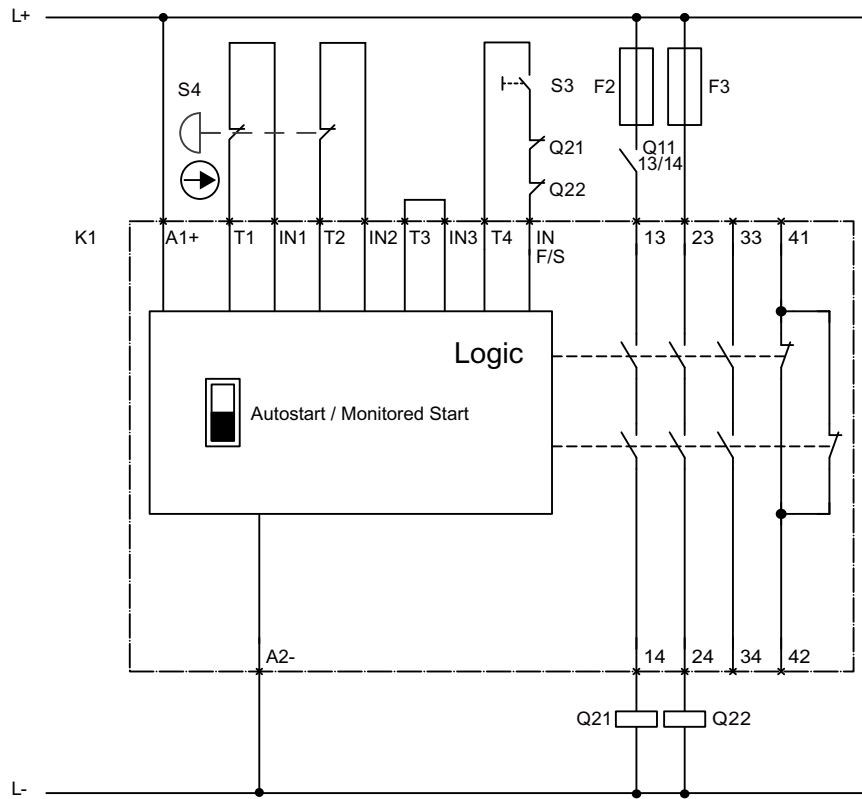

- F2 Fuse
- F3 Fuse
- Q11 Line contactor
- Q21 Contactor
- Q22 Contactor
- S3 Start button
- S4 EMERGENCY STOP
- K1 3SK1111 safety relay

Wiring of the 3SK1 safety relay SIL 3 without line contactor

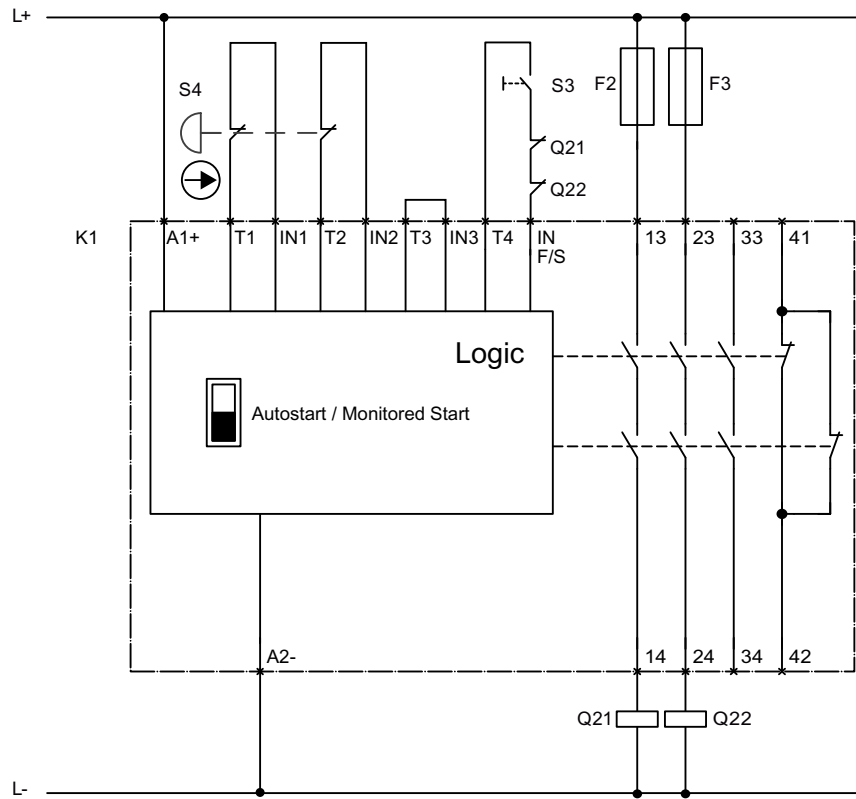

- F2 Fuse
- F3 Fuse
- Q21 Contactor
- Q22 Contactor
- S3 Start button
- S4 EMERGENCY STOP
- K1 3SK1111 safety relay

A.4 3RW55 Failsafe soft starter

Requirements

- 3RW55 Failsafe soft starter

 **WARNING**

**Loss of the safety function due to restricted diagnostics.
Can cause death or serious injury.**

For diagnostics, the 3RW55 Failsafe soft starter must always be directly connected to the main supply voltage (operational voltage).

For diagnostics, always connect the 3RW55 Failsafe soft starter directly to the main supply voltage (operational voltage). Additional contact elements (e.g. a redundant contactor) must only be connected in series behind the 3RW55 Failsafe soft starter.

Note

Compliance with the maximum permissible switching cycles

The safety values only apply considering the maximum permissible switching cycles (B10) of the switching devices used.

- SIL1 application: B10 of the soft starter
- SIL3 application: B10 of the soft starter and B10 of the downstream contactor

Note

Function test

In continuous operation, the key safety values apply in the case of a function test interval for SIL 1 \leq 1 year and for SIL 3 \leq 1 month. The function check is part of the self-test (user-test) (Page 267).

Note

Protection from restarting

Note that, after a safety-related shutoff, an automatic restart cannot be performed.

You will find further information on safety-related shutoff in chapter Failsafe (Page 214).

Note

Cross-circuit proof/short-circuit to power cable proof cable installation

PL e / Cat. 4 according to EN ISO 13849-1 or SIL 3 according to IEC 62061 can only be achieved with cross-circuit proof/short-circuit to power cable proof cable installation between the safety relay (SIL \geq 2) and the 3RW55 Failsafe soft starter or motor contactor (e.g. as cables in separate jackets or in a separate cable duct):

- From the safe output of the safety relay to the failsafe digital input F-DI of the 3RW55 Failsafe soft starter.
- From the failsafe signaling output (output 41, 42; output 4) of the 3RW55 Failsafe soft starter to the safe input of the safety relay.
- From the safe output of the safety relay to operate the motor contactor.

Note

Inside a cabinet, the cabling between the safety relay and the 3RW55 Failsafe soft starter and between the safety relay and the redundant switching element (motor contactor) can be installed in 1 duct. This is also permissible up to SIL 3 / PL e because the cable installation inside the cabinet is short-circuit to power cable/short-circuit proof (fault exclusion according to EN ISO 13849-2).

A.4.1 EMERGENCY STOP shutdown to SIL 1 STO with a 3RW55 Failsafe soft starter

With the 3RW55 Failsafe soft starter, STO applications up to integrity level SIL 1 according to IEC 62061 and PL c / Cat. 2 according to EN ISO 13849 can be implemented without having to use further devices (one-channel shutdown by the 3RW55 Failsafe soft starter). The shutdown command at the failsafe digital input F-DI of the 3RW55 Failsafe soft starter can come from a directly connected EMERGENCY STOP command device or from a safe output of a higher-level safety relay.

Note the requirements in chapter 3RW55 Failsafe soft starter (Page 345).

Basic configuration

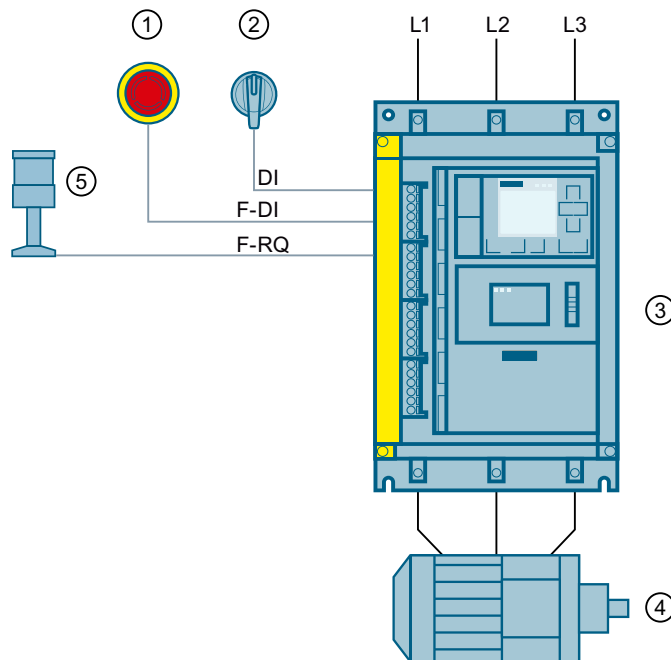

- ① EMERGENCY STOP mushroom pushbutton 3SU1
 - ② Selector switch 3SU1
 - ③ 3RW55 Failsafe soft starter
 - ④ Motor
 - ⑤ Indicator light
- ON: The device has no defect.
 OFF: The 3RW55 Failsafe soft starter is not ready to start (Page 214).
- DI Digital input
 F-DI Failsafe digital input
 F-RQ Failsafe signaling output (output 41, 42; output 4)

Wiring with the 3RW55 Failsafe soft starter

The example shows the 3RW55 Failsafe soft starter with a Standard circuit.

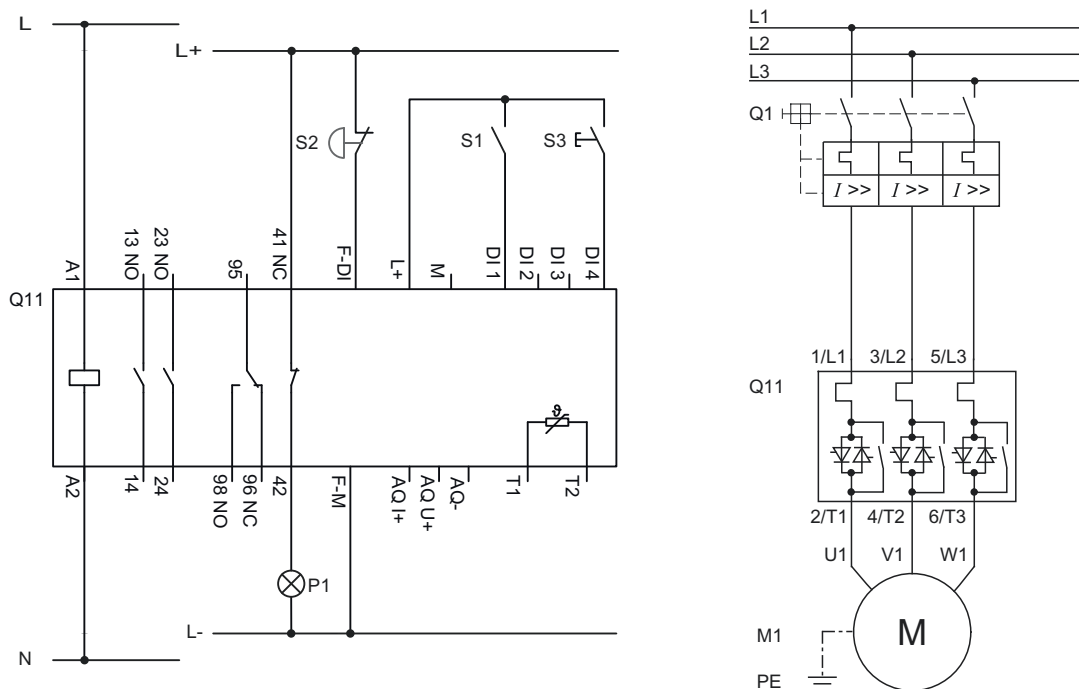

- S1 Switch: Start/stop
- S2 Pushbutton: EMERGENCY OFF
- S3 Pushbutton: Reset
- Q1 Motor starter protector
- Q11 3RW55 Failsafe soft starter
- M1 Motor
- P1 Indicator light
- PE Protective conductor

A.4.2 EMERGENCY STOP shutdown to SIL 2 STO with a 3RW55 Failsafe soft starter

In conjunction with a circuit breaker with an undervoltage release, which is connected between the grid and the soft starter, the 3RW55 Failsafe can be used for Safe Torque Off (STO) applications in a category 2 architecture up to SIL 2 or PL d.

This application is a single-channel shutdown of the motor using the 3RW55 soft starter with emergency off of the motor by the circuit breaker via its undervoltage release in case of soft starter failure. The circuit breaker acts as the output of test equipment (OTE, according to ISO 13849 - 1). The failure of the 3RW55 Failsafe is signaled via its safe signaling output F-RQ (terminal 41/42) to the evaluation unit. Therefore it is a 1-channel architecture (3RW55 Failsafe) with a specified fault reaction (circuit breaker)

Since the circuit breaker must be switched on in order to switch on the soft starter, a closed F-RQ of the soft starter is simulated by the evaluation unit for a short time when the system

is started. This time offset can only be achieved by a parameterizable evaluation unit (3SK2 safety relay or fail-safe controller).

To avoid faults from accumulating undetected, the circuit breaker must be tested after 6 to 12 months at the latest (see "test button" in this example). This test setup must be documented in the description of the safety function and the operating instructions (of the machine). In addition, the tests performed by the user during the use phase must be documented verifiably.

As the circuit breaker, both 3RV (shown here) and 3VA or 3WA, each with an undervoltage release, can be used. Since the undervoltage releases of the circuit breakers sometimes respond sensitively to even short-term voltage interruptions (<1 ms), on the side of safe evaluation units (3SK2 safety relay or fail-safe controller) but dark tests with interruptions of the output voltage of their semiconductor outputs are required, it may be necessary to insert a coupling relay between the semiconductor output of the evaluation unit and the undervoltage release of the circuit breaker. This depends on the circuit breaker used and its undervoltage release (UVR).

- When a SIRIUS 3RV circuit breaker with 24 V DC UVR is used, a dark test time of the semiconductor output of the evaluation unit of 0.6 ms +/- 5% is accepted. If a longer dark test is selected or parameterized for the semiconductor output of the evaluation unit, the UVR would trip on every dark test. For this reason, a coupling relay must be used in this case (e.g. 3RQ12).
- When a SENTRON 3VA circuit breaker with 24 V DC UVR is used, a dark test time of the semiconductor output of the evaluation unit up to 3.0 ms is accepted. If a longer dark test is selected or parameterized for the semiconductor output of the evaluation unit, the UVR would trip on every dark test. For this reason, a coupling relay must be used in this case.
- If a SENTRON 3WA circuit breaker is used, ensure that a delayed undervoltage release is chosen. By setting the time delay, it can be ensured that the dark tests of the evaluation unit do not result in unintentional tripping of the UVR.

When a coupling relay is used between the semiconductor output of the evaluation unit and the undervoltage release of the circuit breaker, the following must be taken into account: The switching status of the coupling relay must be read back into the safe evaluation unit due to the required safety level (SIL 2 or PL d) as part of feedback circuit monitoring. In the 3SK2 safety relays, a 3RQ12 coupling relay certified up to SIL 3 or PL e, whose feedback circuit is transmitted without wiring to the 3SK2 safety relay via the device connector used (see following circuit diagram with 3RQ1200-2EB00). If a fail-safe controller is used, the 3RQ12 coupling relay can also be used to couple the F-DQ channel. Here, the feedback circuit of the 3RQ12 must be wired to a DI channel of the PLC.

If the control source of the 3RW55 Failsafe (represented as selector switch "On") is ON, after an STO request on the 3SK2 and with release of the F-DI signal via the start button on the 3SK2, the motor is automatically started again via the 3RW55 Failsafe without the need for a further release action via a control source on the 3RW55 Failsafe.

Requirements

- Note the requirements in chapter 3RW55 Failsafe soft starter (Page 345).
- If the smooth ramp-down function is set (stopping time setting element set to > 0 s) and the EMERGENCY-STOP circuit is tripped, a "Missing load" error message may be indicated on the 3RW55 Failsafe soft starter. Use Reset to reset the error message.
- Main voltage (operating voltage) is present.

Basic configuration

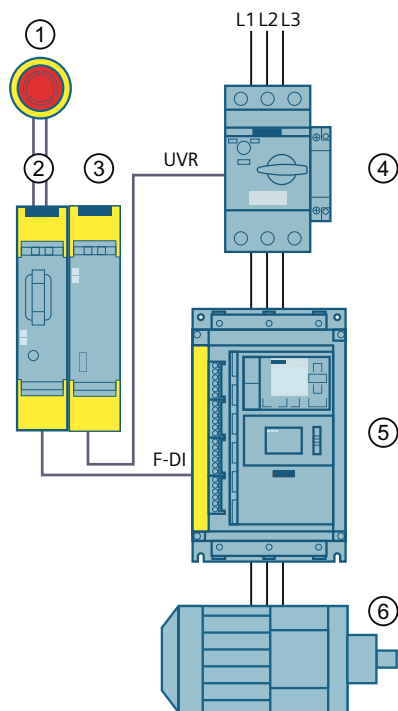

- ① EMERGENCY-STOP mushroom pushbutton 3SU1 for stopping operation
- ② 3SK2 safety relay
- ③ 3RQ12 coupling relay
- ④ 3RV2 circuit breaker with undervoltage release
- ⑤ 3RW55 Failsafe soft starter
- ⑥ Motor
- UVR Undervoltage release
- F-DI Fail-safe digital input

Wiring with the 3RW55 Failsafe soft starter

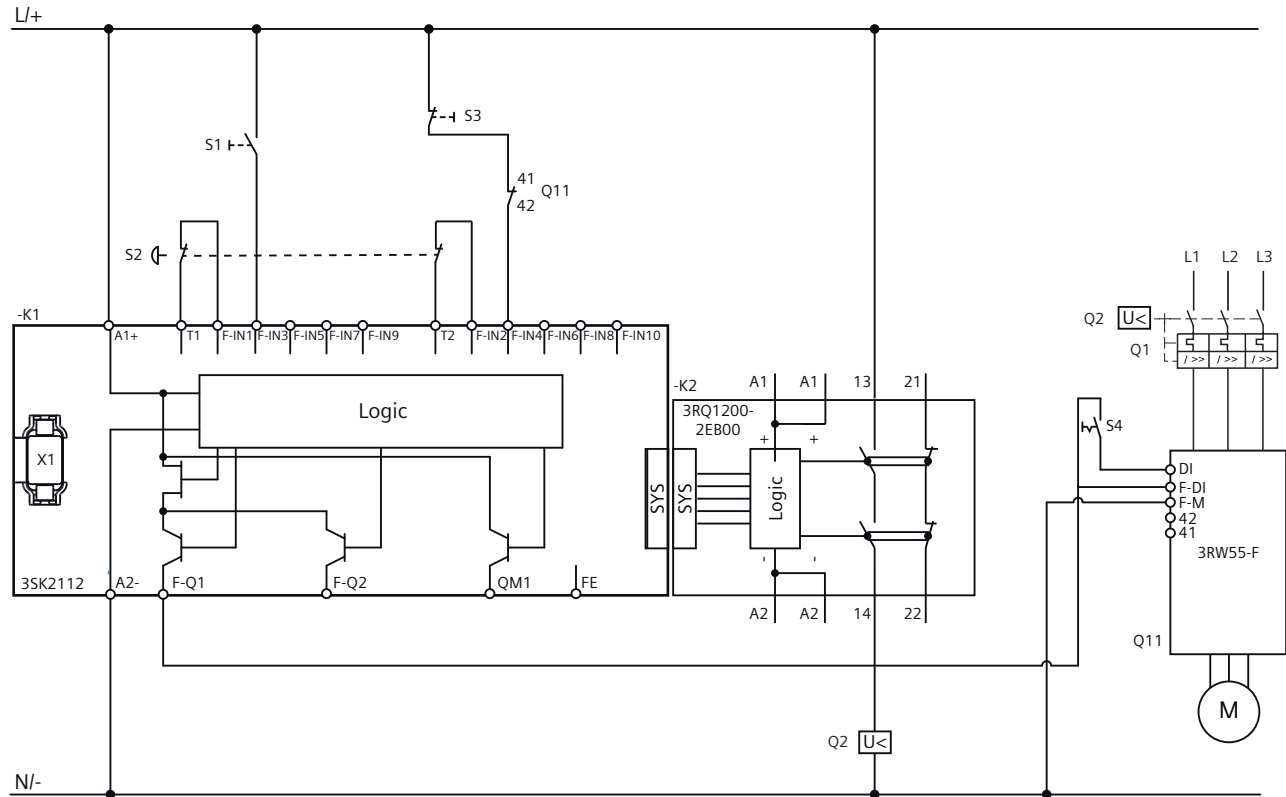

- S1 Switch: Start/stop
- S2 Pushbutton: Reset
- S3 Pushbutton: EMERGENCY OFF
- Q1 Circuit breaker
- Q2 Undervoltage release
- Q11 3RW55 Failsafe soft starter
- K1 3SK2 safety relay
- K2 3RQ12 coupling relay
- M Motor

See also

EMERGENCY STOP shutdown to SIL 3 STO with a 3RW55 Failsafe soft starter with coupling of the digital input DI to the failsafe digital input F-DI (Page 357)

Operating principle (Page 214)

A.4.3 EMERGENCY STOP shutdown to SIL 3 STO with a 3RW55 Failsafe soft starter without coupling of the digital input DI to the failsafe digital input F-DI

Together with an additional motor contactor connected between the 3RW55 Failsafe soft starter and motor, two-channel STO applications can be implemented with the 3RW55 Failsafe soft starter up to integrity level SIL 3 according to IEC 62061 and PL e / Cat. 4 according to EN ISO 13849-1 (two-channel shutdown using the 3RW55 Failsafe soft starter in one of the two channels). The safe signaling output (F-RQ) of the 3RW55 Failsafe soft starter and the auxiliary contacts of the contactor are monitored by a higher-level safety relay with $SIL \geq 2$ (e.g. 3SK1). The control commands at the failsafe digital input F-DI of the 3RW55 Failsafe soft starter and at the contactor come from 2 failsafe outputs of the higher-level safety relay.

Requirements

- Note the requirements in chapter 3RW55 Failsafe soft starter (Page 345).
- If the soft stop function is set (stopping time setting element set to > 0 s) and the EMERGENCY STOP circuit is tripped, a "Missing load" error message may be indicated on the 3RW55 Failsafe soft starter. Use Reset to reset the error message.
- Main supply voltage (operating voltage) is present.

Basic configuration

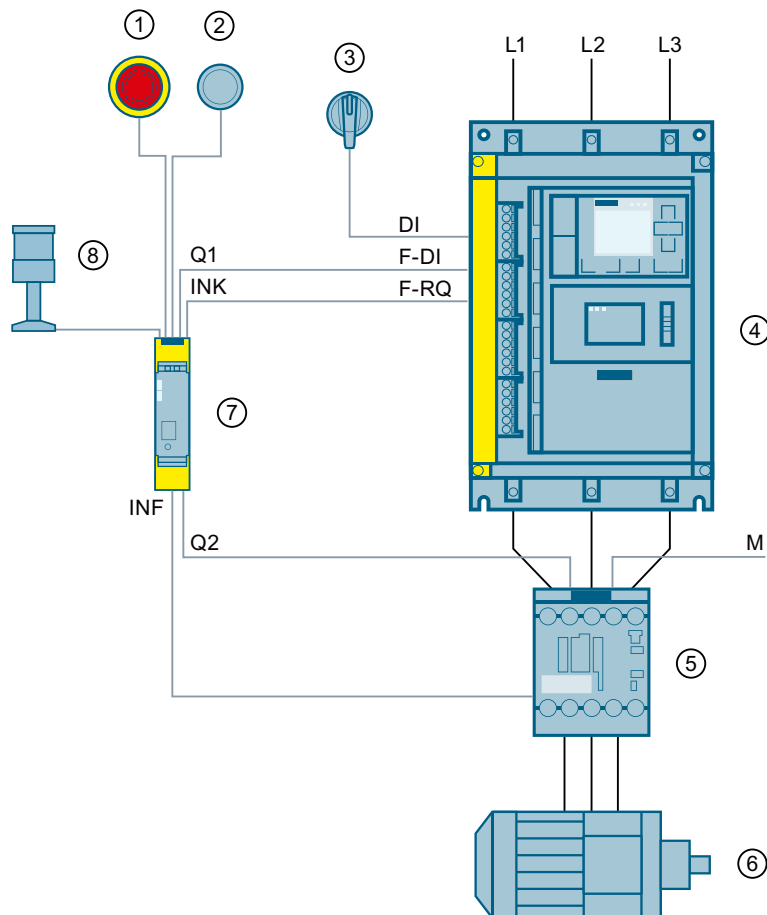

- ① EMERGENCY STOP mushroom pushbutton 3SU1 for stopping operation
 - ② Pushbutton 3SU1 for enabling the safety function
 - ③ Selector switch 3SU1 for functional switching on and off
 - ④ 3RW55 Failsafe soft starter
 - ⑤ 3RT20 contactor
 - ⑥ Motor
 - ⑦ 3SK1 Advanced safety relay
 - ⑧ Indicator light
- ON: The device has no defect.
 OFF: The 3RW55 Failsafe soft starter is not ready to start (Page 214).

- DI Digital input
- F-DI Failsafe digital input
- F-RQ Failsafe signaling output (output 41, 42; output 4)
- M Ground
- Q1 Safety-related output 3SK1
- Q2 Safety-related output 3SK1

INK Cascading circuit 3SK1
INF Feedback circuit 3SK1

Wiring with the 3RW55 Failsafe soft starter

Note

Adaptation of the output current at the failsafe output Q2

If the maximum permissible output current at the failsafe output Q2 of the 3SK1 safety relay is not sufficient, use a coupling link and adapt the magnitude of the output current to switch on the required contactor Q21.

Alternatively, use a 3SK1 safety relay with relay outputs for this.

The example shows the 3RW55 Failsafe soft starter with a Standard circuit.

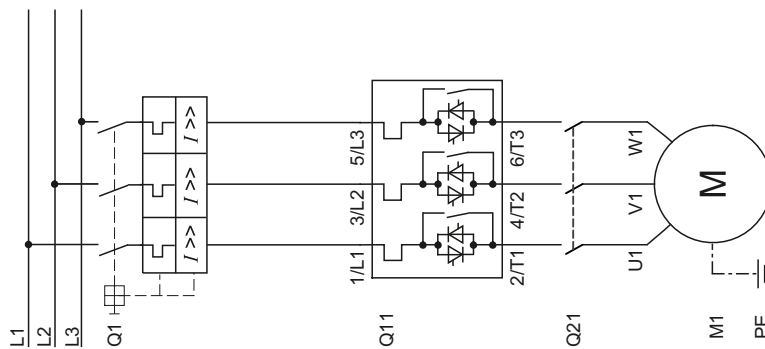

A.4 3RW55 Failsafe soft starter

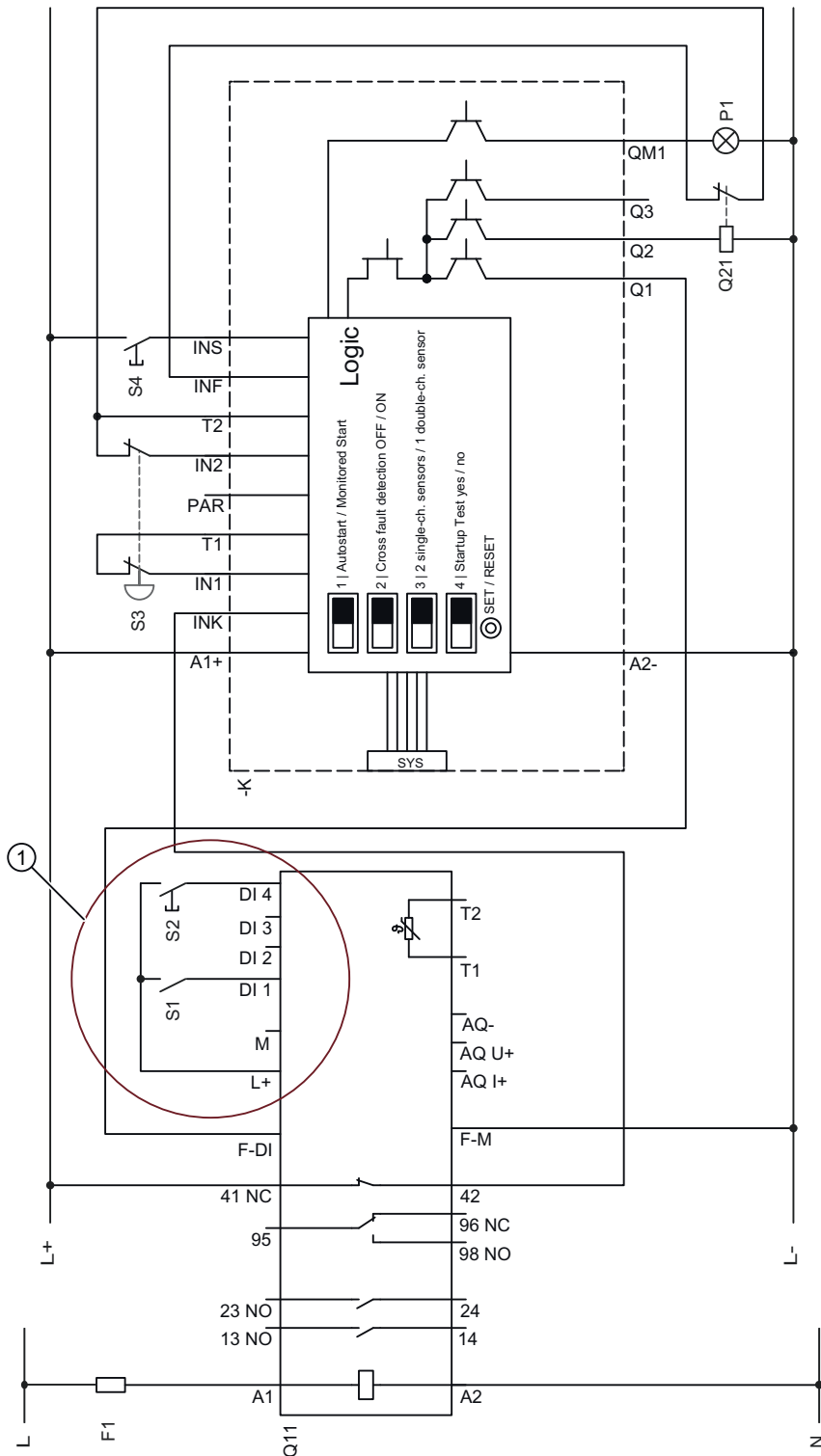

① Difference to the wiring in chapter EMERGENCY STOP shutdown to SIL 3 STO with a 3RW55 Failsafe soft starter with coupling of the digital input DI to the failsafe digital input F-DI (Page 357). In this example of a circuit, no ground connection is required at terminal M because the digital inputs DI1 ... DI4 are supplied from the sensor supply L+.

F1	Fuse
S1	Switch: Start/stop
S2	Pushbutton: Reset
S3	Pushbutton: EMERGENCY OFF
S4	Pushbutton: Monitored start (safety relay)
Q1	Motor starter protector
Q11	3RW55 Failsafe soft starter
Q21	Contactora
K	Safety relay
M1	Motor
P1	Indicator light
PE	Protective conductor

When the EMERGENCY OFF (S3) pushbutton is pressed, the 3RW55 Failsafe soft starter performs the "Safe Torque Off" (STO) safety function. Execution of this safety function is signaled on the display of the 3RW5 HMI High Feature with the message text "Safety-related shutoff". After EMERGENCY OFF (S3) has been reset, the safety relay (K) must also be reset with the Monitored Start pushbutton (safety relay) (S4). Note that for a further start, the start/stop switch (S1) on the 3RW55 Failsafe soft starter must also be switched off and on again.

A.4.4 EMERGENCY STOP shutdown to SIL 3 STO with a 3RW55 Failsafe soft starter with coupling of the digital input DI to the failsafe digital input F-DI

Together with an additional motor contactor connected between the 3RW55 Failsafe soft starter and motor, two-channel STO applications can be implemented with the 3RW55 Failsafe soft starter up to integrity level SIL 3 according to IEC 62061 and PL e / Cat. 4 according to EN ISO 13849-1 (two-channel shutdown using the 3RW55 Failsafe soft starter in one of the two channels). The safe signaling output (F-RQ) of the 3RW55 Failsafe soft starter and the auxiliary contacts of the contactor are monitored by a higher-level safety relay with SIL ≥ 2 (e.g. 3SK1). The control commands at the failsafe digital input F-DI of the 3RW55 Failsafe soft starter and at the contactor come from 2 failsafe outputs of the higher-level safety relay.

Requirements

- Note the requirements in chapter 3RW55 Failsafe soft starter (Page 345).
- If the soft stop function is set (stopping time setting element set to > 0 s) and the EMERGENCY STOP circuit is tripped, a "Missing load" error message may be indicated on the 3RW55 Failsafe soft starter. Use Reset to reset the error message.
- Main supply voltage (operating voltage) is present.

Basic configuration

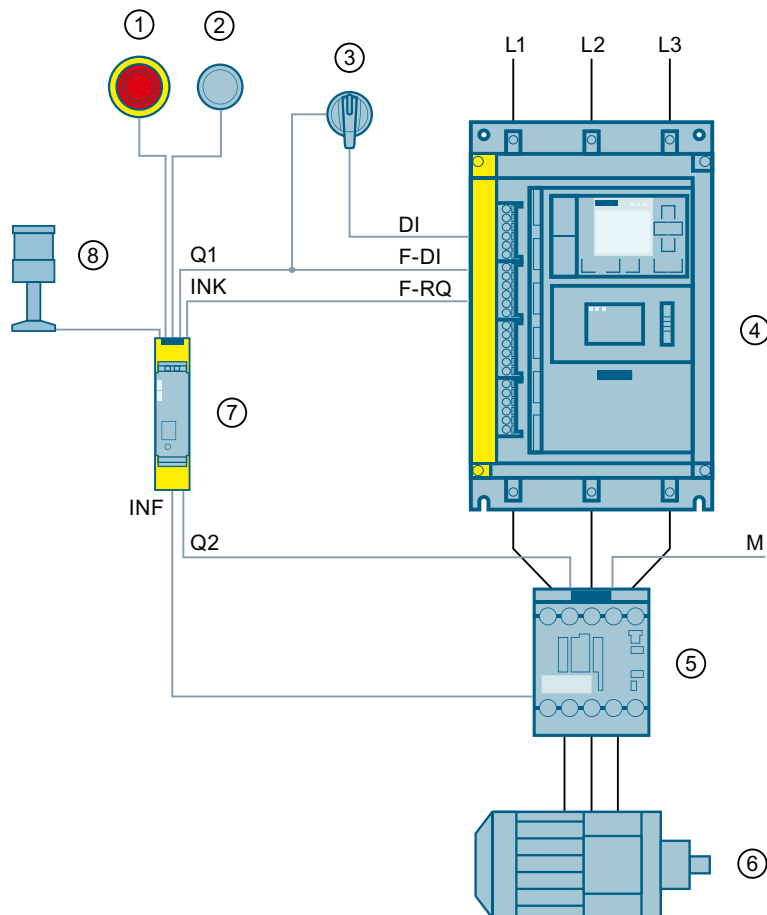

- ① EMERGENCY STOP mushroom pushbutton 3SU1 for stopping operation
 - ② Pushbutton 3SU1 for enabling the safety function
 - ③ Selector switch 3SU1 for functional switching on and off
 - ④ 3RW55 Failsafe soft starter
 - ⑤ 3RT20 contactor
 - ⑥ Motor
 - ⑦ 3SK1 Advanced safety relay
 - ⑧ Indicator light
- ON: The device has no defect.
 OFF: The 3RW55 Failsafe soft starter is not ready to start (Page 214).

- DI Digital input
- F-DI Failsafe digital input
- F-RQ Failsafe signaling output (output 41, 42; output 4)
- M Ground
- Q1 Safety-related output 3SK1
- Q2 Safety-related output 3SK1

INK	Cascading circuit 3SK1
INF	Feedback circuit 3SK1

Wiring with the 3RW55 Failsafe soft starter

Note

Adaptation of the output current at the failsafe output Q2

If the maximum permissible output current at the failsafe output Q2 of the 3SK1 safety relay is not sufficient, use a coupling link and adapt the magnitude of the output current to switch on the required contactor Q21.

Alternatively, use a 3SK1 safety relay with relay outputs for this.

The example shows the 3RW55 Failsafe soft starter with a Standard circuit.

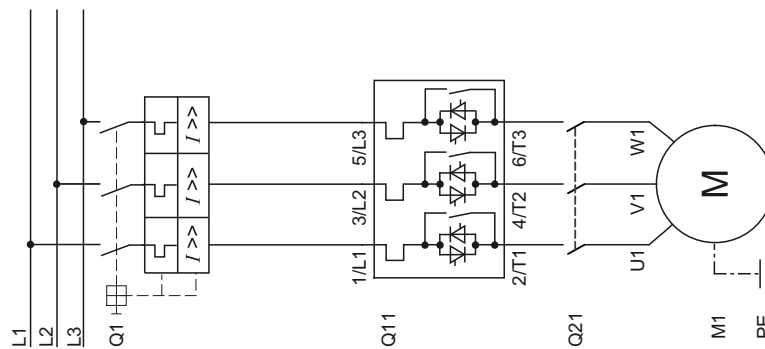

A.4 3RW55 Failsafe soft starter

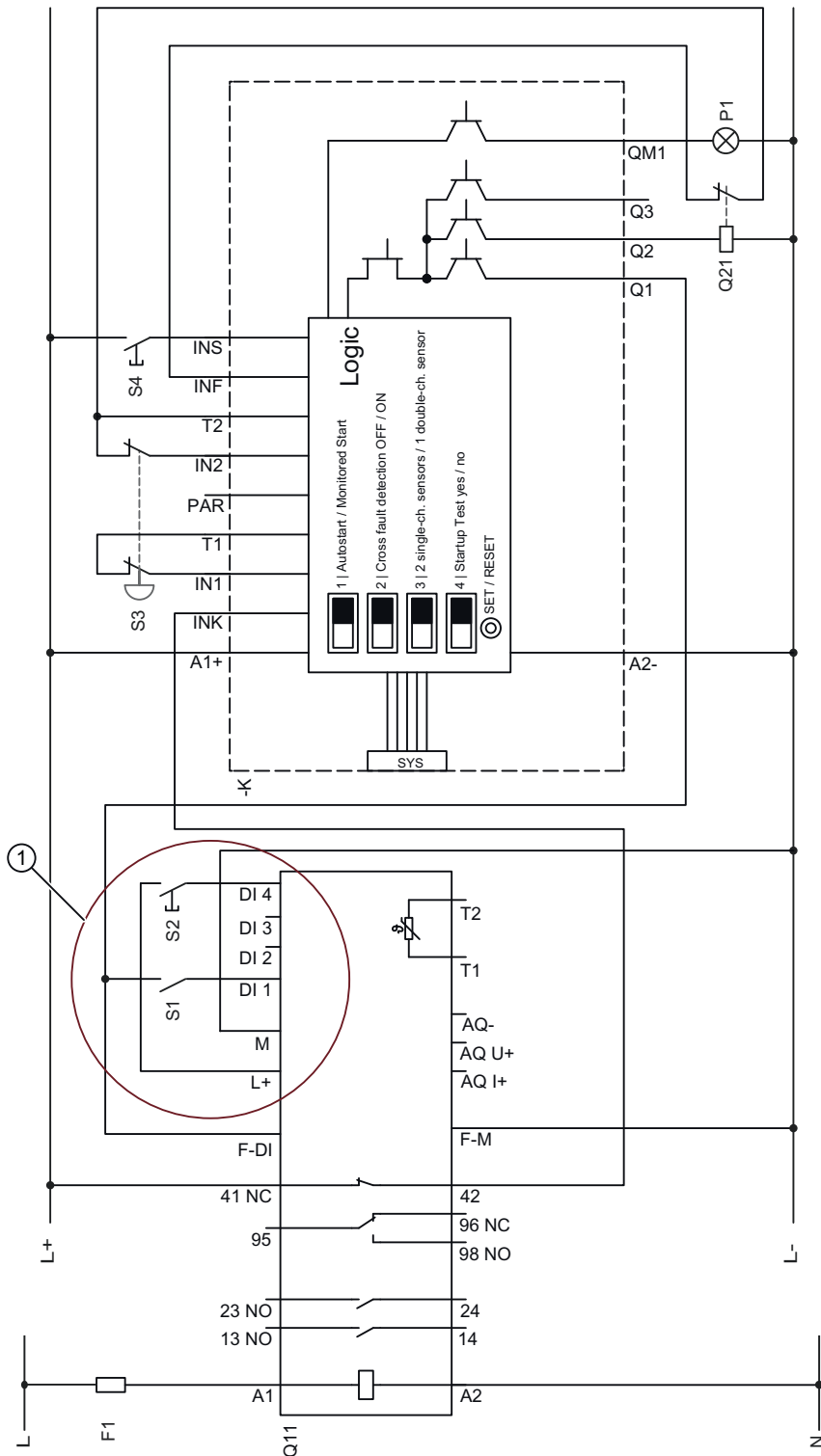

① Difference to the wiring in chapter EMERGENCY STOP shutdown to SIL 3 STO with a 3RW55 Failsafe soft starter without coupling of the digital input DI to the failsafe digital input F-DI (Page 353). In this example of a circuit, terminal M has to be connected to L- because digital input DI1 is supplied with external voltage (L+).

F1	Fuse
S1	Switch: Start/stop
S2	Pushbutton: Reset
S3	Pushbutton: EMERGENCY OFF
S4	Pushbutton: Monitored start (safety relay)
Q1	Motor starter protector
Q11	3RW55 Failsafe soft starter
Q21	Contactora
K	Safety relay
M1	Motor
P1	Indicator light
PE	Protective conductor

When the EMERGENCY OFF (S3) pushbutton is pressed, the signals at the digital inputs DI and F-DI are canceled simultaneously. The 3RW55 Failsafe soft starter executes the "Safe Torque Off" (STO) safety function, which however is not shown in the display of the 3RW5 HMI High Feature. After EMERGENCY OFF (S3) has been reset, the safety relay (K) must also be reset with the Monitored Start pushbutton (safety relay) (S4). If an ON command is still applied at the start/stop switch (S1), a restart is initiated via the 3RW55 Failsafe soft starter.

A.4.5 EMERGENCY STOP shutdown to SIL 3 STO with a 3RW55 Failsafe soft starter in conjunction with bus communication and a safety control

Together with an additional motor contactor connected between the 3RW55 Failsafe soft starter and motor, two-channel STO applications can be implemented with the 3RW55 Failsafe soft starter up to integrity level SIL 3 according to IEC 62061 and PL e / Cat. 4 according to EN ISO 13849-1 (two-channel shutdown using the 3RW55 Failsafe soft starter in one of the two channels). The safe signaling output (F-RQ) of the 3RW55 Failsafe soft starter and the auxiliary contacts of the contactor are monitored by a higher-level safety relay with $SIL \geq 2$ (e.g. safety control). The control commands at the failsafe digital input F-DI of the 3RW55 Failsafe soft starter and at the contactor come from 2 failsafe outputs of the higher-level safety relay.

Note that the EMERGENCY STOP shutdown must only be performed via the safe outputs (Q1 and Q2) of a safety control. Both the shutdown of the contactor and the safety-related shutoff (STO) of the 3RW55 Failsafe soft starter via the failsafe digital input F-DI must be performed via a dedicated safe output (F-DQ) of a safety control.

The feedback signals of the mirror contact of the contactor and of the failsafe signaling output (F-RQ) of the 3RW55 Failsafe soft starter must be made via safe inputs of the safety control. As an alternative to control via the control inputs (DI), functional switching by the 3RW55 Failsafe soft starter can also be performed via a suitable 3RW5 communication module (e.g. PROFINET).

Note the requirements in chapter 3RW55 Failsafe soft starter (Page 345).

Basic configuration for SIL 1

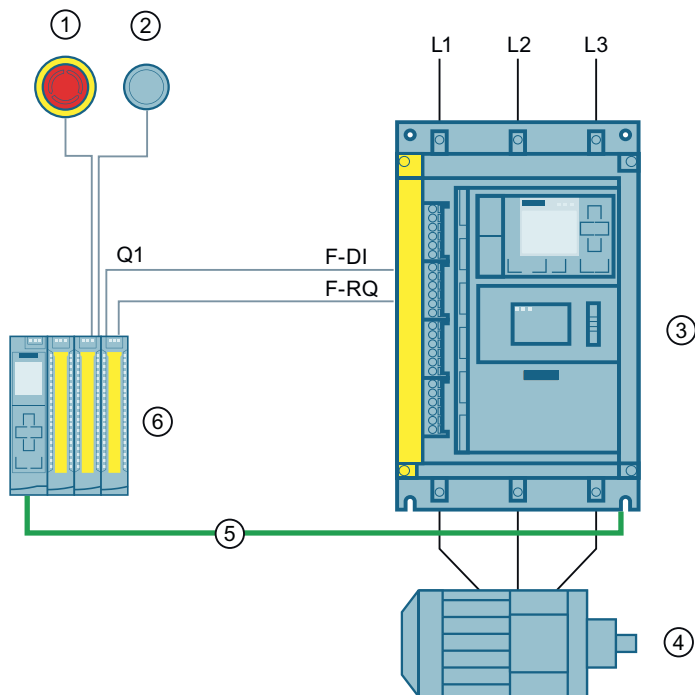

- ① EMERGENCY STOP mushroom pushbutton 3SU1 for stopping operation
- ② Pushbutton 3SU1 for enabling the safety function
- ③ 3RW55 Failsafe soft starter
- ④ Motor
- ⑤ PROFINET (via 3RW5 PROFINET communication module)
- ⑥ Safety control
- Q1 Safety-related output
- F-DI Failsafe digital input
- F-RQ Failsafe signaling output (output 41, 42; output 4)

Basic configuration for SIL 3

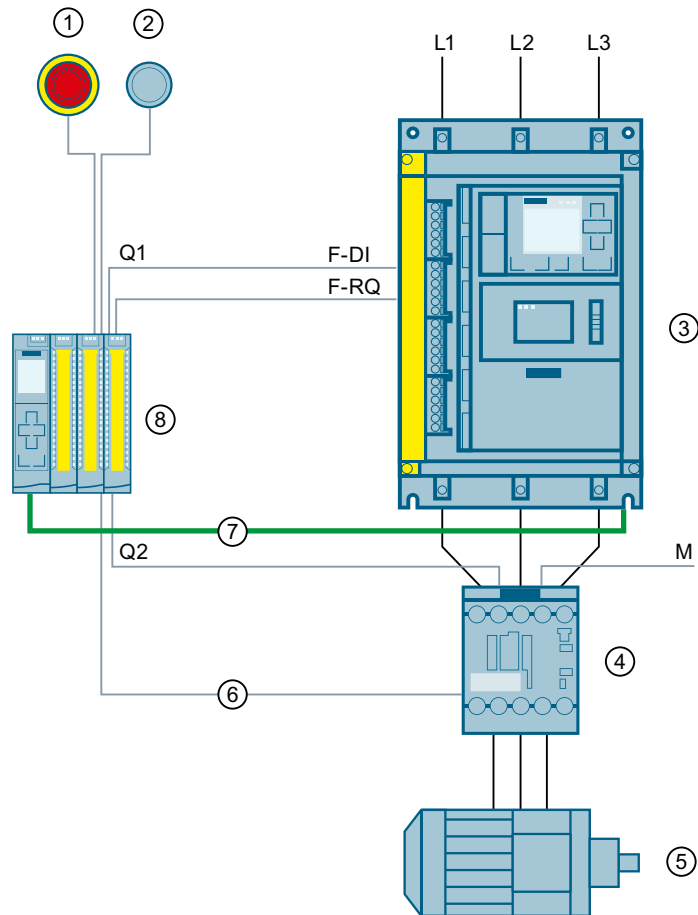

- ① EMERGENCY STOP mushroom pushbutton 3SU1 for stopping operation
- ② Pushbutton 3SU1 for enabling the safety function
- ③ 3RW55 Failsafe soft starter
- ④ 3RT20 contactor
- ⑤ Motor
- ⑥ Mirror contact
- ⑦ PROFINET (via 3RW5 PROFINET communication module)
- ⑧ Safety control
- F-DI Failsafe digital input
- F-RQ Failsafe signaling output (output 41, 42; output 4)
- M Ground
- Q1 Safety-related output
- Q2 Safety-related output

Glossary

Ground fault

Fault whereby an external conductor comes into contact with ground or the grounded neutral point.

GSD

Device master file

This file is required to be able to configure a device as a DP standard slave in the HW Config of a Siemens or external system.

GSDML

Device master file

This file is required to be able to configure a device as a DN device in the HW Config of a Siemens or external system.

HSP

Hardware support package

The hardware support packages allow you to configure modules that are not listed in the hardware catalog of your TIA Portal installation.

PII / PIQ

Process image input/process image output

Process image

Image of the signal states of the digital inputs and outputs in the memory of a controller.

The process images can be transferred as follows:

- Cyclically in the fieldbus protocol
- Acyclically using data sets

STS

Simulation Tool for Soft Starters

The soft starter can be configured with the STS (Simulation Tool for Soft Starters) software. The STS suggests suitable soft starters for the application based on the motor and load data and application requirements that you enter.

Index

3

- 3RW5 HMI High Feature, 30
 - Communication diagnostics, 266
 - Configuring the Function selection key F1-F9, 119
 - Control, 234
 - Control cabinet door, 66
 - Device design and controls, 100
 - Device LED, 251
 - Diagnostics on the 3RW5 HMI High Feature, 266
 - Diagnostics on the 3RW55 Failsafe soft starter, 260
 - Diagnostics on the 3RW55 soft starter, 260
 - Download language, 247
 - Factory setting, 281
 - Faults and remedial actions, 259
 - Firmware update, 279
 - First commissioning, 129
 - Graphical display of measured values, 231
 - Installing, 63, 66
 - Level surface, 64
 - Logbooks, 268
 - Menu, 102
 - Micro SD card, 245
 - Monitoring, 229, 233
 - Mounting, 64
 - Overview, 236
 - Parameterizing, 123
 - Removing, 62
 - Save service data to micro SD card, 269
 - Start key, 121
 - Status LED, 251
 - User login and logout, 244
- 3RW55 Failsafe soft starter
 - Connect main circuit connection (line side/motor side), 77
 - Connecting, 76
 - Connecting the control terminals (screw terminals), 82
 - Connecting the control terminals (spring-loaded terminals), 84
 - Device LEDs, 250
 - Disconnecting the control current form the screw terminals, 83
 - Disconnecting the control current from the spring-loaded terminal, 85
 - Errors and remedial actions, 255
 - Failsafe, 22, 214, 216, 345
 - First commissioning, 127
 - Intrinsic device protection, 173
 - Logbooks, 268
 - Maintenance and repairs, 271
 - Motor parameters, 97
 - Mounting, 57
 - Mounting on a level surface, 58
 - Mounting terminal covers, 78
 - Mounting the cover of the control cable duct, 88
 - Parameterizing, 91
 - Removing the cover of the control cable duct, 89
 - Replacement of the box terminal blocks with size 2, 80
 - Replacing the control terminals, 86
 - Sealing, 128
 - Warnings and remedial measures, 253
- 3RW55 soft starter
 - Connect main circuit connection (line side/motor side), 77
 - Connecting, 76
 - Connecting the control terminals (screw terminals), 82
 - Connecting the control terminals (spring-loaded terminals), 84
 - Device LEDs, 250
 - Disconnecting the control current form the screw terminals, 83
 - Disconnecting the control current from the spring-loaded terminal, 85
 - Errors and remedial actions, 255
 - First commissioning, 127
 - Intrinsic device protection, 173
 - Logbooks, 268
 - Maintenance and repairs, 271
 - Motor parameters, 97
 - Mounting, 57
 - Mounting on a level surface, 58
 - Mounting terminal covers, 78
 - Mounting the cover of the control cable duct, 88
 - Parameterizing, 91
 - Removing the cover of the control cable duct, 89
 - Replacement of the box terminal blocks with size 2, 80
 - Replacing the control terminals, 86
 - Sealing, 128
 - Warnings and remedial measures, 253
- 3RW55 soft starter for serial starting with 3 parameter sets, 325

3RW55 soft starter in standard (inline) circuit and stopping function with DC braking with 2 braking contactors, 315
 3RW55 soft starter in standard (inline) circuit and stopping function with DC braking with one braking contactor, 313
 3RW55 soft starter in standard (inline) circuit with soft starting, soft stopping and the additional function "Creep speed", 317
 3RW55 soft starter with direct-on-line starting (DOL) as emergency start, 332

A

Access options, 32
 Access protection
 3RW55 Failsafe soft starter, 128
 3RW55 soft starter, 128
 Use of PINs, 239
 User account administration, 242
 User login and logout, 244
 Accessories, 51
 Active power monitoring, 179
 Actuation of a line contactor, 304
 Additional parameters, 216
 Bypass operating mode, 216
 Alternative stopping, 165
 Analog output, 204
 Analog output AQ
 PLC, 207
 Application wizard, 94
 Applications, 45
 Asymmetry, 188
 ATEX/IECEX/UKEX, 18, 307, 309
 Ex operation, 209
 Notes, 18
 Automatic parameterization, 134

B

Box terminal block
 Replacing, 80
 Breakaway pulse for startup functions, 146
 Bypass operating mode, 216

C

Catalog, 12

Circuit diagram example, 333, 336
 3RW55 soft starter in standard (inline) circuit and stopping function with DC braking with 2 braking contactors, 315
 3RW55 soft starter in standard (inline) circuit and stopping function with DC braking with one braking contactor, 313
 Actuation of a line contactor, 304
 Connecting the evaluation unit to the analog output, 306
 Connecting the temperature sensor, 305
 Control by PLC, 301
 Control by switch, 302
 EMERGENCY STOP shutdown to SIL 1 or PL c with a 3SK1 safety relay without the 3RW55 Failsafe soft starter, 337
 EMERGENCY STOP shutdown to SIL 3 or PL e with a 3SK1 safety relay, 353, 357
 EMERGENCY STOP shutdown up to SIL 3 or PL e with a 3SK1 safety relay without the 3RW55 Failsafe soft starter, 341
 EMERGENCY STOP shutdown up to SIL 3 or PL e with a safety control, 361
 EMERGENCY STOP shutdown up to SIL 1 or PL c, 347
 Feeder assembly, coordination type 1 fuseless, 293
 Feeder assembly, coordination type 1 with fuses, 295
 Feeder assembly, coordination type 2, 296
 Pump cleaning function with creep speed, 320
 Pump cleaning function with reversing switching element, 322
 Coasting down, 150
 Communication modules, 53
 Complete motor protection, 168
 Condition monitoring, 176
 Active power monitoring, 179
 Current monitoring, 177
 Pump cleaning function, 184
 Starting time monitoring, 183
 Switching frequency monitoring, 180
 Configuring
 Function selection key F1-F9, 119
 Start key, 121
 Connecting the evaluation unit to the analog output, 306
 Connecting the temperature sensor, 305
 Connections
 Overview, 73, 75
 Control, 234
 Control by PLC, 301

Control by switch, 302
 Control via fieldbus with switchover to manual local operation, 319
 Creep speed, 174
 Current monitoring, 177
 Cyclic send data, 207

D

Data transfer, 32
 Date and time
 Setting, 220
 DC braking
 Sensorless motor standstill detection, 164
 DC braking with external braking contactor, 156
 Device change, 283
 Micro SD card, 284
 SIRIUS Soft Starter ES (TIA Portal), 285
 Device LEDs
 Overview, 249
 Device versions, 42
 Diagnostics options, 249
 Digital output actions, 200
 Digital outputs, 200
 Direct-on-line starting, 145
 Download language, 247
 Dynamic DC braking without contactor, 159

E

Edit function favorites, 119
 Electronic motor overload protection, 168
 Emergency run, 193
 Emergency start, 191
 EMERGENCY STOP shutdown to SIL 1 or PL c with a 3SK1 safety relay without the 3RW55 Failsafe soft starter, 337
 EMERGENCY STOP shutdown to SIL 3 or PL e with a 3SK1 safety relay, 353, 357
 EMERGENCY STOP shutdown up to SIL 3 or PL e with a 3SK1 safety relay without the 3RW55 Failsafe soft starter, 341
 EMERGENCY STOP shutdown up to SIL 3 or PL e with a safety control, 361
 EMERGENCY STOP shutdown up to SIL 1 or PL c, 347
 Errors and remedial actions, 255
 3RW55 Failsafe soft starter, 255
 3RW55 soft starter, 255
 Ex operation, 209

Example circuits

3RW55 soft starter for serial starting with 3 parameter sets, 325
 3RW55 soft starter in standard (inline) circuit with soft starting, soft stopping and the additional function "Creep speed", 317
 3RW55 soft starter with direct-on-line starting (DOL) as emergency start, 332
 Control via fieldbus with switchover to manual local operation, 319
 Inside-delta circuit, 297
 Inside-delta circuit in Ex operation with additional line contactor (fuse-protected configuration), 309
 Inside-delta circuit in Ex operation with additional line contactor in the delta, 309
 Reversing duty, 324
 Type of motor connection "Standard" (inline) in Ex operation, 307
 External motor standstill detection, 165

F

Factory setting, 280
 3RW5 HMI High Feature, 281
 Master RESET key, 282
 Options, 281
 Failsafe, 22, 345
 Hardware configuration, 27
 Operating principle, 214
 Resetting safety-related shutoff, 216
 Fan cover
 Mounting, 57
 FAQs, 12
 Faults and remedial actions
 3RW5 HMI High Feature, 259
 Feeder assembly, coordination type 1 fuseless, 293
 Feeder assembly, coordination type 1 with fuses, 295
 Feeder assembly, coordination type 2, 296
 Firmware update, 24, 277
 First commissioning
 3RW55 Failsafe soft starter, 127
 3RW55 soft starter, 127
 Function selection key F1-F9
 Configuring, 119
 Function test, 267
 Functions, 28
 Active power monitoring, 179
 Additional parameters, 216
 Analog output, 204
 Asymmetry, 188
 Automatic parameterization, 134
 Breakaway pulse for startup functions, 146

- Coasting down, 150
- Complete motor protection, 168
- Condition monitoring, 176
- Creep speed, 174
- Current monitoring, 177
- Cyclic send data, 207
- Date and time, 220
- DC braking with external braking contactor, 156
- Digital outputs, 200
- Direct-on-line starting, 145
- Electronic motor overload protection, 168
- Emergency run, 193
- Emergency start, 191
- Ground fault, 189
- Input actions, 196
- Intrinsic device protection, 173
- Motor heating, 145
- Pump cleaning function, 184
- Pump stopping mode, 154
- Soft starting with torque control, 139
- Soft starting with torque control and current limiting, 144
- Soft starting with voltage ramp, 136
- Soft starting with voltage ramp and current limiting, 142
- Starting modes, 133
- Starting time monitoring, 183
- Stopping modes, 148
- Switching frequency monitoring, 180
- Thermistor motor protection with temperature sensor, 171
- Torque control, 152
- Trace function, 222
- User account administration, 242

G

- Graphical display of measured values
 - Bar chart, 231
 - Line chart, 231
- Ground fault, 189

H

- Hardware configuration, 26
- Hinged cover
 - Replacing, 70

I

- Input actions, 196

- Inside-delta circuit, 297
- Interaction interfaces, 32
- Intrinsic device protection, 173

K

- Knowledge, 25

L

- LED test, 267
- LEDs
 - Device LEDs, 249
 - Status and error displays, 250
- Local access protection (PIN), 239
 - Change, 241
 - Defining, 240
 - Delete, 241
- Logbooks, 268

M

- Main circuit connection (line side/motor side)
 - Connecting, 77
- Main menu
 - Monitoring, 229
 - Overview, 236
- Maintenance, 271
- Manuals, 11
- Master RESET key
 - Factory setting, 282
- Menu of the 3RW5 HMI High Feature, 102
- Messages and diagnosis
 - Faults and remedial actions of the 3RW5 HMI High Feature, 259
- Messages and diagnostics
 - Communication diagnostics, 266
 - Diagnostics on the 3RW5 HMI High Feature, 266
 - Diagnostics on the 3RW55 Failsafe soft starter, 260
 - Diagnostics on the 3RW55 soft starter, 260
 - Diagnostics options, 249
 - Logbooks, 268
 - Status and error displays, 250
- Micro SD card, 245
- Micro SD card, 279
- Mode, 34
- Monitoring
 - Measured values, 229
 - Process image, 233

Motor

- Complete motor protection, 168
- Electronic motor overload protection, 168
- Thermistor motor protection with temperature sensor, 171

Motor connection type, 99

Motor heating, 145

Motor parameters, 97

Motor standstill detection, 164, 165

Mounting, 57

Mounting on a level surface, 58

O

Online help, 11

Operating principle

- Alternative stopping, 165
- Dynamic DC braking without contactor, 159
- Reversing DC braking with a reversing contactor assembly, 162
- Voltage ramp, 151

Overview

- I&M data, 236

P

Parameter sets, 93

Parameterizing, 91

- 3RW5 HMI High Feature, 123
- 3RW55 Failsafe soft starter, 91
- 3RW55 soft starter, 91
- Application wizard, 94

Parameters

- Additional parameters, 216

PIN, 239, 244

Process data, 198

Process image input (PII), 198

Process image output (PIQ), 198

Process images, 198

Pump cleaning function, 184

Pump cleaning function with creep speed, 320

Pump cleaning function with reversing switching element, 322

Pump stopping mode, 154

Q

Quick-stop, 176

R

Rated operating speed, 98

Rated operational current, 98

Rated torque, 98

Reactive power compensation, 17

References, 11

Repairs, 271

Reset, 175

Reversing duty, 324

S

Save service data to micro SD card, 269

Screw terminals

- Connecting, 82
- Disconnect the control current, 83

Sealing

- 3RW55 Failsafe soft starter, 128
- 3RW55 soft starter, 128

Self-test (user-test), 267

Sensorless motor standstill detection, 164

Service factor, 98

Setting the mode, 37

Simulation, 226

Simulation Tool for Soft Starters, 46

SIRIUS Soft Starter ES (TIA Portal), 53

- Trace function, 222
- User account administration, 242

Soft starting with torque control and current limiting, 144

Soft starting with voltage ramp, 136, 139

Soft starting with voltage ramp and current limiting, 142

Spring-loaded terminals

- Connecting, 84
- Disconnect the control current, 85

Start key

- Configuring, 121

Starting modes, 133

- Breakaway pulse for startup functions, 146

Direct-on-line starting, 145

Motor heating, 145

Soft starting with torque control, 139

Soft starting with torque control and current limiting, 144

Soft starting with voltage ramp, 136

Soft starting with voltage ramp and current limiting, 142

Starting time monitoring, 183

- Status and error displays, 250
- Stopping modes, 148
 - Alternative stopping, 165
 - Coasting down, 150
 - DC braking with external braking contactor, 156
 - Dynamic DC braking without contactor, 159
 - Pump stopping mode, 154
 - Reversing DC braking with a reversing contactor assembly, 162
 - Torque control, 152
 - Voltage ramp, 151
- Structure of the article number
 - 3RW55 Failsafe soft starter, 49
 - 3RW55 soft starter, 47
- Suggested settings, 95
- Switching frequency monitoring, 180
- System monitoring
 - Condition monitoring, 176

T

- Target group, 25
- Test
 - Current acquisition, 267
 - Motor overload protection, 267
- Test with small load, 224
- Thermistor motor protection with temperature sensor, 171
- Torque control, 152
- Trace function, 222
- Trip class, 171
 - Tripping characteristic, 171

U

- Use of PINs, 239
- User account administration, 242, 244

V

- Voltage ramp, 151

W

- Warnings and remedial measures, 253
 - 3RW55 Failsafe soft starter, 253
 - 3RW55 soft starter, 253