

ANEXA 3

Fitinguri fonta cu flanse

”Construcție a apeductului magistral Sărata-Răzeși – Voinescu – Mingir din r-nul Hîncești”

Nr. crt.	Specificatii tehnice impuse prin Caietul de sarcini	Corespondenta propunerii tehnice cu specificatiile tehnice impuse prin Caietul de sarcini	Producător
0	1		
1	<p>Parametrii tehnici si functionali: Utilizare generala: apa, apa uzata, tratarea apei, industria de productie a hartiei, industria chimica.</p> <ul style="list-style-type: none"> - DN50-250: 16 bar - DN300-450: 7 bar - DN500-600: 4 bar <p>Temperatura maxima: -10°C / +80°C (etansare standard).</p>	<p>Parametrii tehnici si functionali: Utilizare generala: apa, apa uzata, tratarea apei, industria de productie a hartiei, industria chimica.</p> <ul style="list-style-type: none"> - DN50-250: 16 bar - DN300-450: 7 bar - DN500-600: 4 bar <p>Temperatura maxima: -10°C / +80°C (etansare standard).</p>	Jafar Polonia
2	<p>Specificatii de performanta si conditii privind siguranta in exploatare:</p> <ul style="list-style-type: none"> - Respectarea conditiilor de temperatura: -10 □ 80□C; - Amplasare: retea distributie apa potabila; - Lichid de lucru: apa potabila; <p>Montarea se va face conform instructiunilor de montare date de producator.</p>	<p>Specificatii de performanta si conditii privind siguranta in exploatare:</p> <ul style="list-style-type: none"> - Respectarea conditiilor de temperatura: -10 □ 80□C; - Amplasare: retea distributie apa potabila; - Lichid de lucru: apa potabila; <p>Montarea se va face conform instructiunilor de montare date de producator.</p>	Jafar Polonia
3	<p>Conditii privind conformitatea cu standardele relevante:</p> <ul style="list-style-type: none"> - Certificari obligatorii: ISO 9001 - Certificat obligatoriu DVGW; KIWA sau WRAS; - Aviz potabilitate; - Certificare GSK vopsire epoxy; - Vopsire epoxy in acord cu DIN EN 14901; - Emailare interioara si exterioara conform DIN 51178; - Marcaj CE: - Flanse conform EN 1092-2:1999; - Executie conform EN 545:2006; - Certificari obligatorii: Aviz Tehnic si Evaluare tehnica emise de autoritatile din Republica Moldova; <p>Certificare obligatorie:</p> <ul style="list-style-type: none"> - Aviz Sanitar emis de autoritatile din Republica Moldova. 	<p>Conditii privind conformitatea cu standardele relevante:</p> <ul style="list-style-type: none"> - Certificari obligatorii: ISO 9001 - Certificat obligatoriu DVGW; KIWA sau WRAS; - Aviz potabilitate; - Certificare GSK vopsire epoxy; - Vopsire epoxy in acord cu DIN EN 14901; - Emailare interioara si exterioara conform DIN 51178; - Marcaj CE: - Flanse conform EN 1092-2:1999; - Executie conform EN 545:2006; - Certificari obligatorii: Aviz Tehnic si Evaluare tehnica emise de autoritatile din Republica Moldova; <p>Certificare obligatorie:</p> <ul style="list-style-type: none"> - Aviz Sanitar emis de autoritatile din Republica Moldova. 	Jafar Polonia
4	<p>Conditii de garantie si post-garantie:</p> <ul style="list-style-type: none"> - Minim 24 luni de la livrare; - Furnizorul va asigura service in perioada de garantie; - Furnizorul va asigura piese de schimb pe baza de comanda in perioada post-garantie. 	<p>Conditii de garantie si post-garantie:</p> <ul style="list-style-type: none"> - Minim 24 luni de la livrare; - Furnizorul va asigura service in perioada de garantie; - Furnizorul va asigura piese de schimb pe baza de comanda in perioada post-garantie. 	Jafar Polonia

5	Alte conditii cu caracter tehnic: <ul style="list-style-type: none">- Fonta ductila GJS 500-7 EN 1563:2000;- Vopsea epoxidica RAL5005 250 μm^*.	Alte conditii cu caracter tehnic: <ul style="list-style-type: none">- Fonta ductila GJS 500-7 EN 1563:2000;- Vopsea epoxidica RAL5005 250 μm^*.	
---	---	---	--

No.1025/2022/PG

ANEXA 8

Împuternicire producator

[Prezenta împuternicire trebuie sa contina antetul si datele de contact ale Producatorului si sa
fiesemnata de o persoana autorizata sa reprezinte Producatorul la licitatie]

Data: 08.12.2022

Ref.Licitatie: **Construcția apeductului
magistral Sărata-Răzeși – Voinescu – Mingir din r-nul Hîncești**

Catre: **Agenția de Dezvoltare Regională Centru**

Noi Fabryka Armatur JAFAR SA, reprezentati legal prin Pawel Gierut, Adam Kordys, in calitate de Presedinte, Director Comercial, avand facilitatile de productie in str. Kadyiego 38-200 Jaslo, Polonia ca producatori ai **Vane cu setar cauciucat, Fitinguri din fontă cu flanșe, Vane de aerisire cu trei funcții** cu sediul in **SA Darnic Gaz în asociere cu SRL AM Sisteme** sa depuna o oferta completa al carei scop este furnizarea urmatoarelor produse, al caror producatori suntem: **Vane cu setar cauciucat, Fitinguri din fontă cu flanșe, Vane de aerisire cu trei funcții**. De asemenea suntem de acord ca **SA Darnic Gaz în asociere cu SRL AM Sisteme** sa prezinte la prezenta licitatie documentatia tehnica, certificarile si avizarile sanitare, agrementarile si avizarile tehnice specifice si sa puna in opera produsele mentionate mai sus.

Semnat de:

PREZES ZARZADU
DYREKTOR GENERALNY

Pawel Gierut

DYREKTOR HANDLOWY
CZŁONEK ZARZADU

Adam Kordys

In calitate de:

Semnatura:

Stampila:





Certificate No.
NC-1727

CERTIFICATE

Issued for:

Fabryka Armatur „JAFAR” S.A.

**ul. Kadyiego 12
38-200 Jasto**

Management Systems Certification Bureau of Polski Rejestr Statków S.A., al. gen. Józefa Hallera 126, 80-416 Gdańsk, certifies that the Integrated Management System including the Environmental Management System and Occupational Health and Safety Management System of the above organization has been assessed and found to be in accordance with the requirements of:

**ISO 14001:2015
PN-N-18001:2004**

Scope of certification:

**DESIGN, PRODUCTION AND SALE OF WATER SUPPLY, SEWERAGE FITTINGS,
INDUSTRIAL, GAS, HEATING, FIRE PROTECTION AND MARINE FITTINGS,
PRODUCTION AND SALE OF IRON AND STEEL CASTINGS**

DETAILED SCOPE OF CERTIFICATION, SEE THE APPENDIX TO THIS CERTIFICATE

Certificate first issue:

20.02.2008

This Certificate cancels and replaces
the Certificate of:

19.06.2020

The Certificate ISO 14001:2015
is valid until:

22.01.2023

The Certificate PN-N-18001:2004
is valid until:

30.09.2021

Gdańsk, 18.01.2021



Certification Division Director
Michał Chudziński

AC 014

EMS, BHP

The Arrangement IAF MLA refers to EMS

www.prs.pl





Certificate No.
NC-0119

CERTIFICATE

Issued for:

Fabryka Armatur „JAFAR” S.A.

**ul. Kadyiego 12
38-200 Jasło**

Management Systems Certification Bureau of Polski Rejestr Statków S.A., al. gen. Józefa Hallera 126, 80-416 Gdańsk, certifies that the Quality Management System of the above organization has been assessed and found to be in accordance with the requirements of:

ISO 9001:2015

Scope of certification:

**DESIGN, PRODUCTION AND SALE OF WATER SUPPLY, SEWERAGE FITTINGS,
INDUSTRIAL, GAS, HEATING, FIRE PROTECTION AND MARINE FITTINGS,
PRODUCTION AND SALE OF IRON AND STEEL CASTINGS**

DETAILED SCOPE OF CERTIFICATION, SEE THE APPENDIX TO THIS CERTIFICATE

Certificate first issue:

18.03.1999

This Certificate cancels and replaces
the Certificate of:

16.05.2020

The Certificate is valid until:

15.05.2023

Gdańsk, 16.11.2020



Certification Division Director
Michał Chudziński

AC 014
QMS



Annex to the certificate No. NC-0119

issued by Management Systems Certification Bureau of Polski Rejestr Statków S.A.

Issued for:

Fabryka Armatur „JAFAR” S.A.

**ul. Kadyiego 12
38-200 Jasło**

Location:

**Przysieki 87
38-207 Przysieki**

Scope of certification:

**DESIGN, PRODUCTION AND SALE OF WATER SUPPLY, SEWERAGE FITTINGS, INDUSTRIAL, GAS, HEATING,
FIRE PROTECTION AND MARINE FITTINGS**

Location:

**Skołyszyn 259
38-242 Skołyszyn**

Scope of certification:

PRODUCTION AND SALE OF IRON AND STEEL CASTINGS

Gdańsk, 16.11.2020



Certification Division Director
Michał Chudziński



Certificate No.
NC-1727/1

CERTIFICATE

Issued for:

Fabryka Armatur „JAFAR” S.A.

**ul. Kadyiego 12
38-200 Jasło**

Management Systems Certification Bureau of Polski Rejestr Statków S.A., al. gen. Józefa Hallera 126, 80-416 Gdańsk, certifies that the Energy Management System of the above organization has been assessed and found to be in accordance with the requirements of:

ISO 50001:2018

Scope of certification:

**DESIGN, PRODUCTION AND SALE OF WATER SUPPLY, SEWERAGE FITTINGS,
INDUSTRIAL, GAS, HEATING, FIRE PROTECTION AND MARINE FITTINGS,
PRODUCTION AND SALE OF IRON AND STEEL CASTINGS**
DETAILED SCOPE OF CERTIFICATION, SEE THE APPENDIX TO THIS CERTIFICATE

The Certificate is valid until:

25.04.2024



AC 014



Certification Division Director
Michał Chudziński

Gdańsk, 26.10.2021



www.prs.pl

Annex to the certificate No. NC-1727/1

issued by Management Systems Certification Bureau of Polski Rejestr Statków S.A.

Issued for:

Fabryka Armatur „JAFAR” S.A.

**ul. Kadyiego 12
38-200 Jasło**

Location:

**Przysieki 87
38-207 Przysieki**

Scope of certification:

**DESIGN, PRODUCTION AND SALE OF WATER SUPPLY, SEWERAGE FITTINGS, INDUSTRIAL, GAS, HEATING,
FIRE PROTECTION AND MARINE FITTINGS**

Location:

**Skołyszyn 259
38-242 Skołyszyn**

Scope of certification:

PRODUCTION AND SALE OF IRON AND STEEL CASTINGS

Gdańsk, 26.10.2021



Certification Division Director
Michał Chudziński

Cast iron flanged tee connector

PN10
PN16

SEWAGE

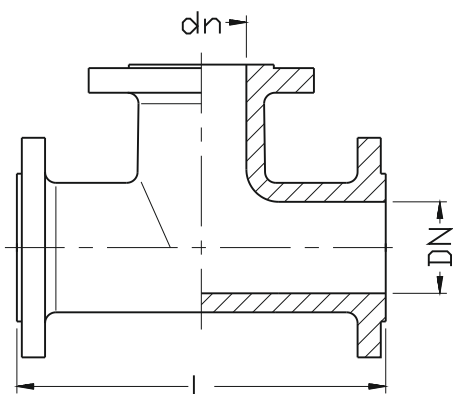
WATER



DN	dn	L	Weight	DN	dn	L	Weight	DN	dn	L	Weight
[mm]			[kg]	[mm]			[kg]	[mm]			[kg]
50	50	300	11,5	250	80	700	65,0	450	100	460	190,0
65	50	330	12,0	250	100	700	69,0	450	150*	500	195*
65	65	330	12,5	250	150	700	70,0	450	200	630	205,0
80	50	330	14,2	250	200	700	80,0	450	300*	745*	218,0*
80	65	330	14,6	250	250	700	89,0	450	450	920	240,0
80	80	330	15,6	300	80	800	93,0	500	80	1000	212,0
100	50	320	18,5	300	100	800	97,0	500	100	1000	215,0
100	65	330/360	20,0	300	150	800	98,0	500	150	1000	255,0
100	80	330/360	18,4	300	200	800	101,0	500	200	1000	262,0
100	100	360	19,3	300	250	800	106,0	500	250	1000	270,0
125	80	400	23,1	300	300	800	125,0	500	300	1000	274,0
125	100	400	23,5	350	150*	530*	123,0*	500	400	1000	285,0
125	125	400	25,5	350	200	585	129,0	500	500	1000	300,0
150	50*	440/325/ 340*	29,5*	350	250*	645*	135,0*	600	80	580	304,0
150	80	440	28,5	350	300	700	141,0	600	200	700	307,0
150	100	440	29,5	350	350	850	167,0	600	400	930	323,0
150	125	440	34	400	80*	900	159,0*	600	600	1100	350,0
150	150	440	32,5	400	100*	900	161,0*	800	200	690	350,0
200	80	520	43,5	400	150*	900	163,0*	800	400	910	430,0
200	100	520	44,5	400	200	900	169,0	800	800	1350	630,0
200	125	440/520	45,0	400	250*	900	175,0*	1000	400	990	650,0
200	150	520	45,5	400	300*	900	179,0*	1000	600	1650	990,0
200	200	520	49,0	400	350*	900	185,0*	-	-	-	-
-	-	-	-	400	400	900	198,0	-	-	-	-

* - on request

Product description (standard execution):

- Made of ductile cast iron EN-GJS 500-7
- UV resistant epoxy coating, to EN 14091
- Flange connection according to EN 1092-2 (DIN 2501), pressure PN10, PN16
- Product according to EN 545
- Hygienic certificate PZH for potable water
- Working pressure PN10 / PN16

Application:

In water supply systems, potable water and other chemically inert liquids as well as raw or industrial sewage

We reserve the rights to modify the production program and the given data without separate notices due to the permanent company development

Flanged bend Type Q

PN10
PN16

SEWAGE

WATER

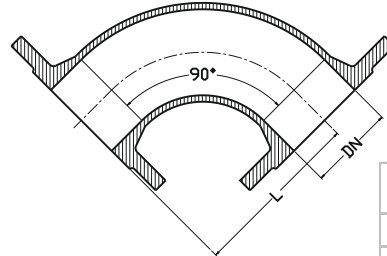

Flanged bend Type Q 9207

DN	L	Weight
[mm]	[mm]	[kg]
50	150	7
65	165	10
80	165	10
100	180	13
125	200	18
150	220	20
200	260	32
250	350	50
300	400	70
350	450	105
400	500	114
500	600	180
600	700	270
800	900	527

Product description (standard execution):

- Made of ductile cast iron EN-GJS 500-7
- UV resistant epoxy coating, to EN 14091
- Flange connection and connector according to EN 1092-2 (DIN 2501), pressure PN10 PN16
- Product according to EN 545
- Hygienic certificate PZH for potable water
- Working pressure PN10 / PN16

Application:

In water supply systems, potable water and other chemically inert liquids as well as raw or industrial sewage

Flanged bend Type FFK

PN10
PN16

SEWAGE

WATER

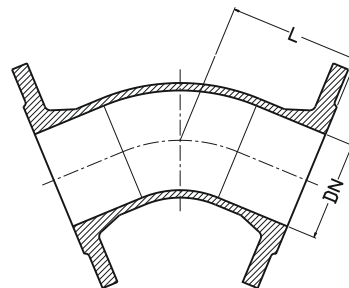

Flanged bend Type FFK 9209

Product description (standard execution):

- Made of ductile cast iron EN-GJS 500-7
- UV resistant epoxy coating, to EN 14091
- Flange connection and connector according to EN 1092-2 (DIN 2501), pressure PN10 PN16
- Product according to EN 545
- Hygienic certificate PZH for potable water
- Working pressure PN10 / PN16

Application:

In water supply systems, potable water and other chemically inert liquids as well as raw or industrial sewage

DN	L	Weight	L	Weight	L	Weight	L	Weight
[mm]	[mm]	[kg]	[mm]	[kg]	[mm]	[kg]	[mm]	[kg]
Angle	11,25°		22,5°		30°		45°	
80	130	9,0	130	9,0	130	10,0	130	10,0
100	140	11,5	140	11,5	140	12,0	140	12,0
150	160	18,5	160	18,5	160	20,0	160	20,0
200	180	28,0	180	28,0	180	29,0	180	29,0
250	210	45,0	210	45,0	210	45,0	350	62,0
300	255	60,0	255	60,0	255	60,0	400	77,0

We reserve the rights to modify the production program and the given data without separate notices due to the permanent company development

Flanged concentric reducer Type FFR

PN10
PN16

SEWAGE

WATER

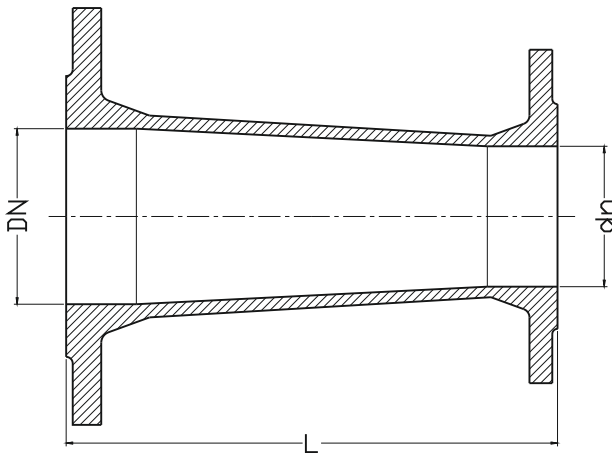

DN	d _n	L	Weight	DN	d _n	L	Weight
	[mm]		[kg]		[mm]		[kg]
50	40	150	5,9	250	80	300	27,5
65	50	200	6,9	250	100	300	28,4
80	40	200	8,0	250	150*	300*	33,0*
80	50	120 / 200	8,4	250	200	300	29,5
80	65	200	8,8	300	100	300	31,3
100	50	200	9,4	300	150	300	36,7
100	65	200	9,8	300	150	300	46,0
100	80	200	10,2	300	200	300	51,0
125	80	200	14,0	300	250	300	50,0
150	50	200	14,2	350	300	300	54,2
150	80	200	14,6	400	200	300	61
150	80*	300*	16,5*	400	250	300	66
150	100	200	14,8	400	300	300	73
150	100	300	16,8	400	350	300	85
200	50	300	22,2	500	300	600	143
200	80	300	22,5	500	400	600	162
200	100	300	27,0	600	400	600	218
200	100*	300*	22,9*	600	500	600	238
200	150	300	23,7	800	600	600	312

Product description (standard execution):

- Made of ductile cast iron EN-GJS 500-7
- UV resistant epoxy coating, EN 14091
- Flange connection according to EN 1092-2 (DIN 2501), pressure PN10, PN16
- Product according to EN 545
- Hygienic certificate PZH for potable water
- Working pressure PN10 / PN16

Application:

In water supply systems, potable water and other chemically inert liquids as well as raw or industrial sewage

We reserve the rights to modify the production program and the given data without separate notices due to the permanent company development

Cast iron flanged elbow with stand Type N

PN10
PN16

SEWAGE

WATER



Cast iron elbow N 9202

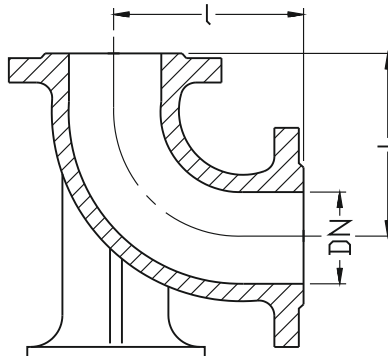

DN	L	Weight
	[mm]	[kg]
80	165	13
100	180	17
150	220	29
200	260	46
250	350	73
300	400	104
400	500	177
500	600	281
600	700	425
800	900	860

Product description (standard execution):

- Made of ductile cast iron EN-GJS 500-7
- UV resistant epoxy coating EN 14091
- Flange connection according to EN 1092-2 (DIN 2501), pressure PN10, PN16
- Product according to EN 545
- Hygienic certificate PZH for potable water
- Working pressure PN10 / PN16

Application:

In water supply systems, potable water and other chemically inert liquids as well as raw or industrial sewage

Flanged cross Type TT

PN10
PN16

SEWAGE

WATER



Flanged cross type CF 9218

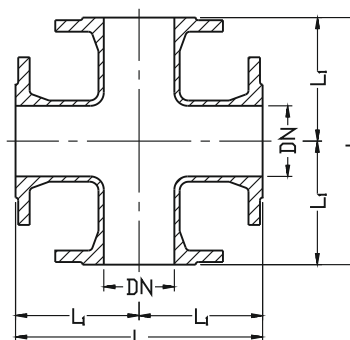

DN	L	L ₁	Weight
	[mm]		[kg]
80	330	165	22
100	360	180	27
150	440	220	50
200	520	260	80
250	700	350	104
300	800	400	145
400	900	450	215
500	1000	500	305
600	1100	550	420

Product description (standard execution):

- Made of ductile cast iron EN-GJS 500-7
- UV resistant epoxy coating, EN 14091
- Flange connection according to EN 1092-2 (DIN 2501), pressure PN10, PN16
- Product according to EN 545
- Hygienic certificate PZH for potable water
- Working pressure PN10 / PN16

Application:

In water supply systems, potable water and other chemically inert liquids as well as raw or industrial sewage

We reserve the rights to modify the production program and the given data without separate notices due to the permanent company development

Cast iron spigot flange Type F

PN10
PN16

SEWAGE

WATER



Cast iron spigot flange Type F 9201

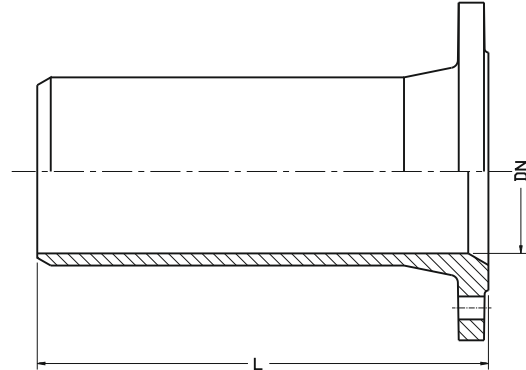

Product description (standard execution):

- Made of ductile cast iron EN-GJS 500-7
- UV resistant epoxy coating to EN 14091
- Flange connection and connector according to EN 1092-2 (DIN 2501), pressure PN10 PN16
- Product according to EN 545
- Hygienic certificate PZH for drinking water
- Working pressure PN10 / PN16

Application:

The water supply system and sewage
Item 9201 for use with cast iron pipes
Item 9221 for use with PVC pipe

DN	L	DN	L
[mm]			
50	340	250	500
65	345	300	440
80	350	350	460
100	360	400	480
125	370	500	520
150	380	600	560
200	400	800	600
250	420	1000	600

Cast iron spigot flange Type FW

PN10
PN16

SEWAGE

WATER

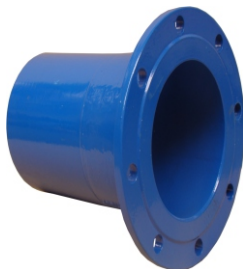

Cast iron spigot flange Type FW 9221

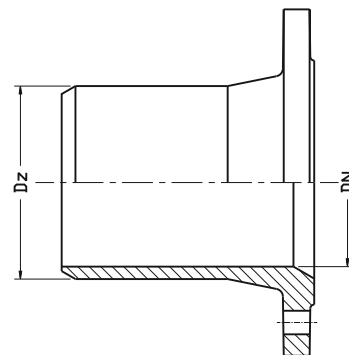

Product description (standard execution):

- Made of ductile cast iron EN-GJS 500-7
- UV resistant epoxy coating to EN 14091
- Flange connection and connector according to EN 1092-2 (DIN 2501), pressure PN10 PN16
- Product according to EN 545
- Hygienic certificate PZH for drinking water
- Working pressure PN10 / PN16

Application:

The water supply system and sewage
Item 9201 for use with cast iron pipes
Item 9221 for use with PVC pipe

DN	D _z
[mm]	
80	90
100	110
150	160
200	225
250	280
300	315
400	450
500	560
600	630

We reserve the rights to modify the production program and the given data without separate notices due to the permanent company development



Mitglied bei/Member of:



RAL GÜTEZEICHEN
SCHWERER KORROSIONSSCHUTZ
VON ARMATUREN UND FORMSTÜCKEN

AWARD CERTIFICATE

Production heavy corrosion protection of valves and fittings

The Quality Association for Heavy Duty Corrosion Protection of Valves and Fittings by Powder Coating e.V. (GSK) awards based on the test report of the externally supervising body presented to the Quality Committee and on the resolution of the Executive Committee of GSK for the coating procedure for the production of heavy corrosion protection for valves and fittings and for the product families mentioned in the appendix to the company:

Fabryka Armatur JAFAR S.A.
ul. Przysieki 87, 38-207 Przysieki, POLAND

the right to use the quality mark with the performance-related addition RAL-GZ 662/2.

The quality mark is certified by the Institute for Quality Assurance and Certification e.V. (RAL) and protected by registration at the German Patent and Trademark Office as a collective trademark (EU trademark 009300138).



The products, which were manufactured according to the quality and test regulations (GPB) of the GSK, are designated as product families by the enterprise to the association's office and listed in the appendix and on the GSK homepage (www.gsk-online.de). They receive the following marking:

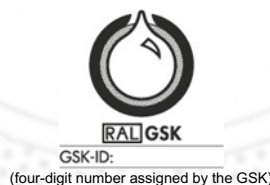

This certificate is valid until 31st December 2024

Schwäbisch Gmünd, the 31st December 2021

Lars Walther
Managing Director

Not valid without annex

The product families must be listed in the certificate. The holder of the quality mark informs GSK about the inclusion of new products or changes to existing products in the product approval, and GSK in turn informs the testing institutes. The current list of product families manufactured in GSK quality can be found on the GSK website (www.gsk-online.de).



Mitglied bei/Member of:



RAL GÜTEZEICHEN
SCHWERER KORROSIONSSCHUTZ
VON ARMATUREN UND FORMSTÜCKEN

Annex to the certificate of 31st December 2021

The certificate of the company

Fabryka Armatur JAFAR S.A.
ul. Przysieki 87, 38-207 Przysieki, POLAND

is valid for the following product families

No.	Product	nominal size
1	Soft wedge gate valves (group 2000), Type 2111, 2002, 2911, 2902, 2511, 2502, 2120, 2112, 2115, 2123, 2125, 2901, 2903, 2700	DN 32 - DN 600
2	Wedge gate valves for natural gas (group 2000), Type 2311, 2302, 2312, 2314, 2931, 2932	DN 32 - DN 600
3	House connectors (group 3000) , Type 3050, 3100, 3150, 3151, 3160	DN 50 - DN 150
4	House connectors (group 3000). Type 3116, 3126, 3216, 3217, 3218	DN 25 - DN 50
5	House connectors (group 3000) - Type 3500	DN 20 - DN 50
6	Butterfly valves (group 4000) - Type 4493	DN 200 - DN 1200
7	Gas filters (group 7000) - Type 7310	DN 20 - DN 80
8	Gas filters (group 7000) - Type 7320	DN 50 - DN 80
9	Overground hydrants (group 8000) - type 8003 (version 8003.2 and 8003.4 with stainless steel column or with galvanized steel column)	DN 80 - DN 100
10	Overground hydrants (group 8000) - type 8004 (version 8004.2 with stainless steel column or with galvanized steel column)	DN 80 - DN 100
11	Underground hydrants (group 8000) -Type 8850	DN 80
12	Underground hydrants (group 8000) - Type 8851 (version 8851.4 with stainless steel column or with galvanized steel column)	DN 80
13	Underground hydrants (group 8000) - Type 8852 (version 8852.2 and 8852.4 with stainless steel column or with galvanized steel column)	DN 80



Mitglied bei/Member of:



RAL GÜTEZEICHEN
SCHWERER KORROSIONSSCHUTZ
VON ARMATUREN UND FORMSTÜCKEN

Annex to the certificate of 31st December 2021

The certificate of the company

Fabryka Armatur JAFAR S.A.
ul. Przysieki 87, 38-207 Przysieki, POLAND

is valid for the following product families

No.	Product	nominal size
14	Underground hydrants (group 8000) - Type 8853 version with galvanized steel column)	DN100 – DN125
15	Overground hydrants (group 8000) - type 8855 (version 8855.2 with stainless steel column)	DN 80 – DN 100
16	Overground hydrants (group 8000) - type 8855 (version 8855.4 with stainless steel column)	DN 80
17	Overground hydrants (group 8000) - type 8855 (version 8855.5 with stainless steel column)	DN 80
18	Fittings and accessories (group 9000), Type 9102, 9103, 9104, 9123, 9151, 9152	DN 40 - DN 800
19	Fittings and accessories (group 9000) - Type 9163	DN 60 – DN 300

CARSO - LABORATOIRE SANTÉ ENVIRONNEMENT HYGIÈNE DE LYON

Laboratoire Agréé pour les analyses d'eaux par le Ministère de la Santé

Laboratoire habilité par le Ministère chargé de la santé en application de l'article R*.1321-52 du code de la santé publique

ATTESTATION DE CONFORMITE SANITAIRE

Certificate of sanitary conformity

Conformément à l'arrêté du 29 mai 1997 modifié et à la circulaire du Ministère de la Santé
Direction Générale de la Santé DGS/SD7A N° 571 du 25 Novembre 2002

Coordonnées du demandeur d'ACS / Contact details of the ACS owner :

FABRYKA ARMATUR JAFAR SA

UL. KADYIEGO 12,

38 - 200 JASŁO

Pologne

Nom de l'accessoire représentatif / Reference of the representative accessory :

Clapet anti-retour / Ball check valve 6516 DN50

N° de dossier attribué par le laboratoire habilité / File reference :

21 ACC LY 369

Date de réalisation des essais d'inertie selon la norme XP P41-280 : aucun essai de migration n'est nécessaire

Tests date (according to the standard XP P 41-280) : No testing is required to issue this ACS

Commentaires : les composants organiques sont conformes à l'arrête du 29 mai 1997 modifié. Les composants métalliques sont conformes à l'arrêté du 25 juin 2020

Comments : organic components are compliant with the decree dated 29th May 1997 modified. Metallic components are compliant with the decree dated 25th June 2020.

Famille d'accessoires couverte par l'ACS / Accessories' family covered by this certificate :

Clapets anti-retour / Ball check valves

Références / References (8 references) :

6516	Ball check valve flanged	DN 50 à DN 500
6616	Ball check valve threaded ends	DN 25 à DN 50
6526	Ball check valve flanged	DN 50 à DN 500
6626	Ball check valve threaded ends	DN 25 à DN 50
6524	Check valve flanged	DN 40 à DN 300
6525	Non return check valve flanged	DN 50 à DN 250
6534	Check valve wafer	DN 40 à DN 300
6535	Non return check valve interflanged	DN 40 à DN 400

Attestation délivrée par / Certificate issued by :

Christelle AUTUGELLE

Signature :

Responsable MCDE

CARSO - L.S.E.H.L.

Date de délivrance / Date of issue : 21 Mai 2021

Date d'expiration / Expiry date : 21 Mai 2026

Commentaires / Comments : Renouvellement / Renewal 16 ACC LY 260

Société par action simplifiée au capital de 2 283 622,38 Euros - RCS Lyon B 410 545 313 - SIRET 410 545 313 00042 - APE 743 B - N° TVA - FR 82 410 545 313

F_MC060-b 15/05/2014 Laboratoire : 4, avenue Jean Moulin - CS 30228 - F - 69633 VENISSIEUX cedex - Tél. : (33) 04 72 76 16 16 - Fax : (33) 04 78 72 35 03

Site web : www.groupecarso.com - e-mail : mcde@groupecarso.com

CARSO - LABORATOIRE SANTÉ ENVIRONNEMENT HYGIÈNE DE LYON

Laboratoire Agréé pour les analyses d'eaux par le Ministère de la Santé

Laboratoire habilité par le Ministère chargé de la santé en application de l'article R*.1321-52 du code de la santé publique

ATTESTATION DE CONFORMITE SANITAIRE

Certificate of sanitary conformity

Conformément à l'arrêté du 29 mai 1997 modifié et à la circulaire du Ministère de la Santé

Direction Générale de la Santé DGS/SD7A N° 571 du 25 Novembre 2002

Coordonnées du demandeur d'ACS / Contact details of the ACS owner :

FABRYKA ARMATUR JAFAR SA

UL. KADYIEGO 12,

38 - 200 JASŁO

Pologne

Nom de l'accessoire représentatif / Reference of the representative accessory :

Collier de prise en charge / Saddle for water 3150 DN63

N° de dossier attribué par le laboratoire habilité / File reference :

21 ACC LY 370

Date de réalisation des essais d'inertie selon la norme XP P41-280 : aucun essai de migration n'est nécessaire

Tests date (according to the standard XP P 41-280) : No testing is required to issue this ACS

Commentaires : les composants organiques sont conformes à l'arrête du 29 mai 1997 modifié. Les composants métalliques sont conformes à l'arrête du 25 juin 2020

Comments : organic components are compliant with the decree dated 29th May 1997 modified. Metallic components are compliant with the decree dated 25th June 2020.

Famille d'accessoires couverte par l'ACS / Accessories' family covered by this certificate :

Colliers de prise en charge / Saddles for water

Références / References (5 references) :

3050	Clamp saddles with flange	Outlet DN 50 à DN 150 / Pipe connection Dz90 - Dz900
3100	Clamp saddles with threaded	Outlet DN 50 outlet / Pipe connection Dz90 - Dz738 pipe connection
3150	Connectors for water line networks	Outlet DN 50 / Plastic Pipe connection Dz63 - 225
3160	Connectors for water line networks	Outlet DN 50 / Plactic Pipe connection Dz90 - 315
3151	Connectors for water line networks	Outlet DN 50 à DN 150 / Plastic Pipe connection Dz63 - Dz400

Attestation délivrée par / Certificate issued by :

Christelle AUTUGELLE

Signature :

Responsable MCDE

CARSO - L.S.E.H.L.

Date de délivrance / Date of issue : 21 Mai 2021

Date d'expiration / Expiry date : 21 Mai 2026

Commentaires / Comments : Renouvellement / Renewal 16 ACC LY 261

Société par action simplifiée au capital de 2 283 622,38 Euros - RCS Lyon B 410 545 313 - SIRET 410 545 313 00042 - APE 743 B - N° TVA : FR 82 410 545 313

F_MC060-b 19/09/2014 WLA Laboratoire : 4, avenue Jean Moulin - CS 30228 - F - 69633 VENISSIEUX cedex - Tél. : (33) 04 72 76 16 16 - Fax : (33) 04 78 72 35 03

Site web : www.groupecarso.com - e-mail : mcde@groupecarso.com

ATTESTATION DE CONFORMITE SANITAIRE
Certificate of sanitary conformity

Conformément à l'arrêté du 29 mai 1997 modifié et à la circulaire du Ministère de la Santé
Direction Générale de la Santé DGS/SD7A N° 571 du 25 Novembre 2002

Coordonnées du demandeur d'ACS / Contact details of the ACS owner :

FABRYKA ARMATUR JAFAR SA
UL. KADYIEGO 12,
38 - 200 JASŁO
Pologne

Nom de l'accessoire représentatif / Reference of the representative accessory :

Filtre à tamis en Y / Strainer flanged ends 7110 DN50

N° de dossier attribué par le laboratoire habilité / File reference : **21 ACC LY 371**

Date de réalisation des essais d'inertie selon la norme XP P41-280 : aucun essai de migration n'est nécessaire

Tests date (according to the standard XP P 41-280) : No testing is required to issue this ACS

Commentaires : les composants organiques sont conformes à l'arrête du 29 mai 1997 modifié. Les composants métalliques sont conformes à l'arrêté du 25 juin 2020

Comments : organic components are compliant with the decree dated 29th May 1997 modified. Metallic components are compliant with the decree dated 25th June 2020.

Famille d'accessoires couverte par l'ACS / Accessories' family covered by this certificate :

Filtre à tamis / Strainer flanged ends

Référence / Reference (1 reference) :

7110 Strainer flanged ends DN50 à DN300

Attestation délivrée par / Certificate issued by : Christelle AUTUGELLE
Responsable MCDE
CARSO - L.S.E.H.L.

Signature :



Date de délivrance / Date of issue : 06 Janvier 2022

Date d'expiration / Expiry date : 21 Mai 2026

Commentaires / Comments : Renouvellement / **Renewal 16 ACC LY 262**

CARSO - LABORATOIRE SANTÉ ENVIRONNEMENT HYGIÈNE DE LYON

Laboratoire Agréé pour les analyses d'eaux par le Ministère de la Santé

Laboratoire habilité par le Ministère chargé de la santé en application de l'article R*.1321-52 du code de la santé publique

ATTESTATION DE CONFORMITE SANITAIRE Certificate of sanitary conformity

Conformément à l'arrêté du 29 mai 1997 modifié et à la circulaire du Ministère de la Santé

Direction Générale de la Santé DGS/SD7A N° 571 du 25 Novembre 2002

Coordonnées du demandeur d'ACS / Contact details of the ACS owner :

FABRYKA ARMATUR JAFAR SA
UL. KADYIEGO 12,
38 - 200 JASŁO
Pologne

Nom de l'accessoire représentatif / Reference of the representative accessory :

Raccord / Pipe connector RR multidiameter 9102 DN50

N° de dossier attribué par le laboratoire habilité / File reference : **21 ACC LY 372**

Date de réalisation des essais d'inertie selon la norme XP P41-280 : aucun essai de migration n'est nécessaire

Tests date (according to the standard XP P 41-280) : No testing is required to issue this ACS

Commentaires : les composants organiques sont conformes à l'arrête du 29 mai 1997 modifié. Les composants métalliques sont conformes à l'arrête du 25 juin 2020

Comments : organic components are compliant with the decree dated 29th May 1997 modified. Metallic components are compliant with the decree dated 25th June 2020.

Famille d'accessoires couverte par l'ACS / Accessories' family covered by this certificate :

Raccords / Pipe connectors

Références / References (19 references) :

Voir Annexe Jointe / See Annex enclosed

(1 page)

Attestation délivrée par / Certificate issued by :

Christelle AUTUGELLE

Signature :

Responsable MCDE

CARSO - L.S.E.H.L.

Date de délivrance / Date of issue : 21 Mai 2021

Date d'expiration / Expiry date : 21 Mai 2026

Commentaires / Comments : Renouvellement / **Renewal 16 ACC LY 263**

ANNEXE à l'ACS 21 ACC LY 372

Raccords couverts par l'ACS / Pipe connectors covered with ACS 21 ACC 372

9101	Caulker	DN 50 to DN 300
9219	Blind flange X	DN 50 to DN 1000
9102	Pipe connector RR multidiameter	DN 50 to DN 800
9103	Flanged connector for PE pipes	DN 50 to DN 600
9104	Pipe connector RK multidiameter	DN 50 to DN 800
9122	Pipe connector RR	DN 40 to DN 400
9123	Pipe connector for PE pipes	DN 50 to DN 300
9144	Pipe connector RK	DN 50 to DN 400
9151	Pipe connector	DN 40 to DN 300
9152	Pipe connector	DN 50 to DN 300
9205	Flange and socket tee MMA	DN 80 to DN 600
9206	Socket tee MMB	DN 100 to DN 300
9208	Double socket bend MMQ	DN 80 to DN 600
9210	Double socket bend MMK	DN 80 to DN 600
9217	Flanged and socket pieces	DN 50 to DN 700
9222	Shock absorber - flanged	DN 32 to DN 600
9223	Shock absorber - threaded	DN 20 to DN 80
9232	Elbow N for PE pipes	DN 80
9311	Dismantling piece type F3	DN 32 to DN 2400

Christelle AUTUGELLE
Responsable Laboratoire MCDE
A la date du : 21 Mai 2021

Signature :



CARSO - LABORATOIRE SANTÉ ENVIRONNEMENT HYGIÈNE DE LYON

Laboratoire Agréé pour les analyses d'eaux par le Ministère de la Santé

Laboratoire habilité par le Ministère chargé de la santé en application de l'article R*.1321-52 du code de la santé publique

ATTESTATION DE CONFORMITE SANITAIRE

Certificate of sanitary conformity

Conformément à l'arrêté du 29 mai 1997 modifié et à la circulaire du Ministère de la Santé

Direction Générale de la Santé DGS/SD7A N° 571 du 25 Novembre 2002

Coordonnées du demandeur d'ACS / Contact details of the ACS owner :

FABRYKA ARMATUR JAFAR SA

UL. KADYIEGO 12,

38 - 200 JASŁO

Pologne

Nom de l'accessoire représentatif / Reference of the representative accessory :

Ventouse avec flotteur Inox / Air release valve for water, with stainless steel float 7050 DN50

N° de dossier attribué par le laboratoire habilité / File reference :

21 ACC LY 373

Date de réalisation des essais d'inertie selon la norme XP P41-280 : aucun essai de migration n'est nécessaire

Tests date (according to the standard XP P 41-280) : No testing is required to issue this ACS

Commentaires : les composants organiques sont conformes à l'arrête du 29 mai 1997 modifié. Les composants métalliques sont conformes à l'arrête du 25 juin 2020

Comments : organic components are compliant with the decree dated 29th May 1997 modified. Metallic components are compliant with the decree dated 25th June 2020.

Famille d'accessoires couverte par l'ACS / Accessories' family covered by this certificate :

Ventouses avec flotteur Inox / Air release valves for water, with stainless steel float

Références / References (4 references) :

7010 Air valve for potable water one stage DN 50 to DN 200

7040 Air release valve for water DN 3/4" to DN 6/4"

7050 Air release valve for water DN 50 to DN 200

7080 Air release valve for water DN 50 to DN 100

Attestation délivrée par / Certificate issued by :

Christelle AUTUGELLE

Signature :

Responsable MCDE

CARSO - L.S.E.H.L.

Date de délivrance / Date of issue : 21 Mai 2021

Date d'expiration / Expiry date : 21 Mai 2026

Commentaires / Comments : Renouvellement / Renewal 16 ACC LY 480

Société par action simplifiée au capital de 2 283 622,38 Euros - RCS Lyon B 410 545 313 - SIRET 410 545 313 00042 - APE 743 B - N° TVA : FR 82 410 545 313

F_MC060-b 15/09/2014 Laboratoire : 4, avenue Jean Moulin - CS 30228 - F - 69633 VENISSIEUX cedex - Tél. : (33) 04 72 76 16 16 - Fax : (33) 04 78 72 35 03

Site web : www.groupecarso.com - e-mail : mcde@groupecarso.com

ATTESTATION DE CONFORMITE SANITAIRE
Certificate of sanitary conformity

Conformément à l'arrêté du 29 mai 1997 modifié et à la circulaire du Ministère de la Santé
Direction Générale de la Santé DGS/SD7A N° 571 du 25 Novembre 2002

Coordonnées du demandeur d'ACS / Contact details of the ACS owner :

FABRYKA ARMATUR JAFAR SA
UL. KADYIEGO 12,
38 - 200 JASŁO
Pologne

Nom de l'accessoire représentatif / Reference of the representative accessory :

Raccord / Pipe connector RR multidiameter 9102 DN50

N° de dossier attribué par le laboratoire habilité / File reference : 21 ACC LY 372

Date de réalisation des essais d'inertie selon la norme XP P41-280 : aucun essai de migration n'est nécessaire

Tests date (according to the standard XP P 41-280) : No testing is required to issue this ACS

Commentaires : les composants organiques sont conformes à l'arrête du 29 mai 1997 modifié. Les composants métalliques sont conformes à l'arrêté du 25 juin 2020

Comments : organic components are compliant with the decree dated 29th May 1997 modified. Metallic components are compliant with the decree dated 25th June 2020.

Famille d'accessoires couverte par l'ACS / Accessories' family covered by this certificate :

Raccords / Pipe connectors

Références / References (20 references) :

Voir Annexe Jointe / See Annex enclosed
(1 page)

Attestation délivrée par / Certificate issued by :

Christelle AUTUGELLE
Responsable MCDE
CARSO - L.S.E.H.L.

Signature :

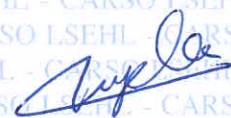

Date de délivrance / Date of issue : 07 Janvier 2022

Date d'expiration / Expiry date : 21 Mai 2026

Commentaires / Comments : Renouvellement / Renewal 16 ACC LY 263.

Mise à jour de l'ACS par ajout de références. Cette ACS conserve donc la même date d'expiration que celle émise le 21 Mai 2021 / This ACS is an update of the ACS issued on May 21, 2021 (additional references). Consequently, its expiry date remains the same.

ANNEXE à l'ACS 21 ACC LY 372

Raccords couverts par l'ACS / *Pipe connectors covered with ACS* 21 ACC 372

9101	Caulker	DN 50 to DN 300
9219	Blind flange X	DN 50 to DN 1000
9102	Pipe connector RR multidiameter	DN 50 to DN 800
9103	Flanged connector for PE pipes	DN 50 to DN 600
9104	Pipe connector RK multidiameter	DN 50 to DN 800
9122	Pipe connector RR	DN 40 to DN 400
9123	Pipe connector for PE pipes	DN 50 to DN 300
9144	Pipe connector RK	DN 50 to DN 400
9151	Pipe connector	DN 40 to DN 300
9152	Pipe connector	DN 50 to DN 300
9163	Flange adaptor for ductle iron pipe	DN 60 to DN 300
9205	Flange and socket tee MMA	DN 80 to DN 600
9206	Socket tee MMB	DN 100 to DN 300
9208	Double socket bend MMQ	DN 80 to DN 600
9210	Double socket bend MMK	DN 80 to DN 600
9217	Flanged and socket pieces	DN 50 to DN 700
9222	Shock absorber - flanged	DN 32 to DN 600
9223	Shock absorber - threaded	DN 20 to DN 80
9232	Elbow N for PE pipes	DN 80
9311	Dismaintling piece type F3	DN 32 to DN 2400

Christelle AUTUGELLE
Responsable Laboratoire MCDE
A la date du : 07 Janvier 2022

Signature :





CERT

DIN-DVGW type examination certificate

DIN-DVGW-Baumusterprüfzertifikat

NW-6203CS0191

Registration Number
Registriernummer

Field of Application <i>Anwendungsbereich</i>	products of water supply <i>Produkte der Wasserversorgung</i>
Owner of Certificate <i>Zertifikatinhaber</i>	Fabryka Armatur JAFAR S.A. Kadyiego 12, PL-38-200 Jaslo
Distributor <i>Vertreiber</i>	Fabryka Armatur JAFAR S.A. Kadyiego 12, PL-38-200 Jaslo
Product Category <i>Produktart</i>	valves for water supply: gate valve (6203)
Product Description <i>Produktbezeichnung</i>	soft wedge gate valves with flange connection, for the drinking water supply
Model <i>Modell</i>	2002/2111
Test Reports <i>Prüfberichte</i>	laboratory control test: 2-0119/21 from 01.10.2021 (TZW) type testing: A0 002/17 from 16.06.2017 (TZW)
Test Basis <i>Prüfgrundlagen</i>	DVGW W 363-(P) (01.06.2010) DIN EN 1074-1 (01.07.2000) DIN EN 1074-2 (01.07.2004) UBA ELASTOM (16.03.2016) UBA Übergangsregelung KTW-BWGL (10.07.2020) DVGW W 270 (01.11.2007)
Date of Expiry / File No. <i>Ablaufdatum / Aktenzeichen</i>	16.06.2027 / 22-0422-WNV

70028-04-A-DE

27.09.2022 Fk A-1/2

Date, Issued by, Sheet, Head of Certification Body
Datum, Bearbeiter, Blatt, Leiter der Zertifizierungsstelle



Deutsche
Akkreditierungsstelle
D-ZE-16028-01-05

DVGW CERT GmbH
Zertifizierungsstelle

Josef-Wirmer-Str. 1-3
53123 Bonn

Tel. +49 228 91 88 - 888
Fax +49 228 91 88 - 993

www.dvgw-cert.com
info@dvgw-cert.com

Type Typ	Technical Data Technische Daten	Remarks Bemerkungen
2002/2111	pressure rating: PN 10/16 nominal diameter: DN 32	
2002/2111	pressure rating: PN 10/16 nominal diameter: DN 40	
2002/2111	pressure rating: PN 10/16 nominal diameter: DN 50	
2002/2111	pressure rating: PN 10/16 nominal diameter: DN 65	
2002/2111	pressure rating: PN 10/16 nominal diameter: DN 80	
2002/2111	pressure rating: PN 10/16 nominal diameter: DN 100	
2002/2111	pressure rating: PN 10/16 nominal diameter: DN 125	
2002/2111	pressure rating: PN 10/16 nominal diameter: DN 150	
2002/2111	pressure rating: PN 10/16 nominal diameter: DN 200	
2002/2111	pressure rating: PN 10/16 nominal diameter: DN 250	
2002/2111	pressure rating: PN 10/16 nominal diameter: DN 300	
2002/2111	pressure rating: PN 10/16 nominal diameter: DN 350	
2002/2111	pressure rating: PN 10/16 nominal diameter: DN 400	
2002/2111	pressure rating: PN 10/16 nominal diameter: DN 450	
2002/2111	pressure rating: PN 10/16 nominal diameter: DN 500	
2002/2111	pressure rating: PN 10/16 nominal diameter: DN 600	

Type Variation Ausführungsvariante	Explanations Erläuterungen
2111	serie 14
2002	serie 15

certified Components

zertifizierte Bauteile / Werkstoffe

Registr. No. Registr.-Nr.	Component Bauteil (Produktart)	Model/Type Modell/Typ	Manufacturer Hersteller
HW-1011DN0470	assembled product, product group P1	2002, 2111, 2502, 2511, 2902, 2911, 3116, 3126/Absperrschieber	Fabryka Armatur JAFAR S.A.



CERT

DVGW type examination certificate

DVGW-Baumusterprüfzertifikat

DW-6201DL0312

Registration Number
Registriernummer

Field of Application <i>Anwendungsbereich</i>	products of water supply <i>Produkte der Wasserversorgung</i>
Owner of Certificate <i>Zertifikatinhaber</i>	Fabryka Armatur JAFAR S.A. Kadyiego 12, PL-38-200 Jaslo
Distributor <i>Vertreiber</i>	Fabryka Armatur JAFAR S.A. Kadyiego 12, PL-38-200 Jaslo
Product Category <i>Produktart</i>	valves for water supply: butterfly valve (6201)
Product Description <i>Produktbezeichnung</i>	butterfly valve, double concentric, with flange connections
Model <i>Modell</i>	4493
Test Reports <i>Prüfberichte</i>	type testing: A0 036/20 from 11.09.2020 (TZW) type testing: A0 050/20 from 07.09.2020 (TZW) UBA-Guideline: K-279733-17-Bs/st from 05.01.2017 (WHY) hygienic testing: W-279700k-17-SI/Krü from 21.12.2016 (WHY)
Test Basis <i>Prüfgrundlagen</i>	DVGW W 363-(P) (01.06.2010) DIN EN 1074-1 (01.07.2000) DIN EN 1074-2 (01.07.2004) UBA BWGL-Metalle (14.05.2020) UBA ELASTOM (16.03.2016) UBA BESCH-LL (16.03.2016) DVGW W 270 (01.11.2007)
Date of Expiry / File No. <i>Ablaufdatum / Aktenzeichen</i>	11.09.2025 / 20-0126-WNE

70028 04-A-DE

01.10.2020 Fk A-1/2

Date, Issued by, Sheet, Head of Certification Body
Datum, Bearbeiter, Blatt, Leiter der Zertifizierungsstelle

DVGW CERT GmbH is an accredited body by DAkkS according to DIN EN ISO/IEC 17065:2013 for certification of products for energy and water supply industry.

DVGW CERT GmbH ist von der DAkkS nach DIN EN ISO/IEC 17065:2013 akkreditierte Stelle für die Zertifizierung von Produkten der Energie- und Wasserversorgung.



Deutsche
Akkreditierungsstelle
D-ZE-16028-01-05

DVGW CERT GmbH
Zertifizierungsstelle

Josef-Wirmer-Str. 1-3
53123 Bonn

Tel. +49 228 91 88 - 888
Fax +49 228 91 88 - 993

www.dvgw-cert.com
info@dvgw-cert.com

Type <i>Typ</i>	Technical Data <i>Technische Daten</i>	Remarks <i>Bemerkungen</i>
4493	nominal pressure rating: PN 10/16 nominal diameter: DN 200	
4493	nominal pressure rating: PN 10/16 nominal diameter: DN 250	
4493	nominal pressure rating: PN 10/16 nominal diameter: DN 300	
4493	nominal pressure rating: PN 10/16 nominal diameter: DN 350	
4493	nominal pressure rating: PN 10/16 nominal diameter: DN 400	
4493	nominal pressure rating: PN 10/16 nominal diameter: DN 450	
4493	nominal pressure rating: PN 10/16 nominal diameter: DN 500	
4493	nominal pressure rating: PN 10/16 nominal diameter: DN 600	
4493	nominal pressure rating: PN 10/16 nominal diameter: DN 700	
4493	nominal pressure rating: PN 10/16 nominal diameter: DN 800	
4493	nominal pressure rating: PN 10/16 nominal diameter: DN 1000	
4493	nominal pressure rating: PN 10/16 nominal diameter: DN 1200	



NARODOWY INSTYTUT ZDROWIA PUBLICZNEGO - Państwowy Zakład Higieny
NATIONAL INSTITUTE OF PUBLIC HEALTH - National Institute of Hygiene

ZAKŁAD BEZPIECZEŃSTWA ZDROWOTNEGO ŚRODOWISKA
DEPARTMENT OF ENVIRONMENTAL HEALTH AND SAFETY

ATEST HIGIENICZNY

B-BK-60210-1680/20

HYGIENIC CERTIFICATE

ORYGINAL

NATIONAL INSTITUTE OF PUBLIC HEALTH – NATIONAL INSTITUTE OF HYGIENE

Wyrób / product: **Fittings for water pipes: gate valves; butterfly valves; spotters; connectors; stub pipes; hydeants; public taps; household, repair and connection network fittings;joints;bands; pipe fittings;gates;sprinklers;wells;accessories as per the company catalogue**

Zawierający / containing: ductile iron, gray iron, steel, brass, Resicoat RE-ES HJF01R coating, EPDM, other materials as specified in the manufacturer's declaration

Przeznaczony do / destined: installation in systems used for the transport of water intended for human consumption

Wymieniony wyżej produkt odpowiada wymaganiom higienicznym przy spełnieniu następujących warunków / the above-named product is acceptable according to hygienic criteria with the following conditions:

This hygienic certificate does not apply to technical parameters and utility value of the product.

Wytwórca / producer:

Fabryka Armatur "JAFAR" Spółka Akcyjna
38-200 Jasło
ul. Kadyiego 12

Niniejszy dokument wydano na wniosek / this certificate issued for:

Fabryka Armatur "JAFAR" Spółka Akcyjna
38-200 Jasło
ul. Kadyiego 12

Atest może być zmieniony lub unieważniony po przedstawieniu stosownych dowodów przez którąkolwiek stronę. Niniejszy atest traci ważność po 2023.11.02 lub w przypadku zmian w recepturze albo w technologii wytwarzania wyrobu.

The certificate may be corrected or cancelled after appropriate motivation. The certificate loses its validity after 2023.11.02 or in the case of changes in composition or in technology of production.

Data wydania atestu higienicznego: 4 stycznia 2021

The date of issue of the certificate: 4th January 2021

Kierownik
Zakładu Bezpieczeństwa Zdrowotnego
Środowiska

dr hab. Jolanta Solecka, prof. NIZP-PZH

Kontakt w sprawie niniejszego atestu higienicznego / To contact regarding this hygienic certificate
Zakład Bezpieczeństwa Zdrowotnego Środowiska NIZP-PZH / Department of Environmental Health and Safety NIPH-NIH
00-791 Warszawa, ul. Chocimska 24 / 00-791 Warsaw, Chocimska 24, Poland
e-mail: sekretariat-bk@pzh.gov.pl tel. +48 22 54-21-354, +48 22 54-21-349



AC 114

CERTYFIKAT BADANIA PROJEKTU UE EU DESIGN EXAMINATION CERTIFICATE

Nr
No. CW/PED/3/12/2020

ZAŚWIADCZA SIĘ, ŻE

Polski Rejestr Statków S.A. (PRS) przeprowadził procedurę zatwierdzenia projektu wymienionego niżej wyrobu i stwierdził, że spełnia wymagania określone w dyrektywie 2014/68/UE, urządzenia ciśnieniowe.

THIS IS TO CERTIFY THAT

Polski Rejestr Statków S.A. (PRS) did undertake the design approval procedure for the product identified below which was found in conformity with requirements of the Pressure Equipment Directive 2014/68/EU.

Wnioskodawca
Applicant**Fabryka Armatur JAFAR SA**
ul. Kaydiego 12, 38-200 JasłoProducent
Manufacturer**Fabryka Armatur JAFAR SA**
ul. Kaydiego 12, 38-200 JasłoWyrób
Product**Armatura przemysłowa**
Industrial valves

Wykaz produktów – patrz załącznik do certyfikatu.
List of products – see appendix to certificate.

Zastosowane normy
Specified standardsCertyfikat jest ważny do
This certificate is valid until

2023.08.30

Niniejszy certyfikat straci ważność po wprowadzeniu zmian lub modyfikacji w wyrobie bez pisemnego zawiadomienia i zgody PRS.
This certificate becomes invalid after changes/modifications to the product, which have not been notified to and agreed with the PRS.

Zastępca Dyrektora Pionu Certyfikacji
Deputy Certification Division Director

Gdańsk, 2020.12.03

NOTIFIED BODY
NO 1463

Przemysław Gałka

Nr jednostki notyfikowanej
No. of notified body

1463

Polski Rejestr Statków S.A.
al. Gen. Józefa Hallera 126
80-416 Gdańsk, PolandTel. (+48) (58) 346 17 00
fax (+48) (58) 341 77 69
e-mail: dc@prs.pl
www: <http://www.prs.pl/>

Wykaz zbadanej dokumentacji
List of examined documentation

Dokumentacja armatury w zakresie według załącznika, zawiera:

- karty katalogowe,
- dokumentację techniczno-ruchową DTR,
- rysunki konstrukcyjne,
- instrukcję stanowiskowe,

The documentation of the fittings in the scope according to the appendix includes:

- *data sheets,*
- *technical documentation,*
- *construction drawings,*
- *instruction manual.*

Numery atestów materiałowych
Nos. of material certificates

Inne miejsca produkcji
Other places of production

Wnioski z badań
Conclusions of the tests

Kwestionariusz auditu nr CW/PED/9/08/2020/O
Protocol of audit no CW/PED/9/08/2020/O

Uwagi
Remarks

Badanie projektu dotyczy armatury wyszczególnionej w załączniku.
The design study concerns of the fittings In the scope according to the appendix.

ZAŁĄCZNIK DO CERTYFIKATU NR CW/PED/3/12/2020

ANNEX TO CERTIFICATE No. CW/PED/3/12/2020

WYKAZ ARMATURY OBJĘTEJ CERTYFIKATEM

LIST OF VALVES

Typ Type	Grupa płynów Fluid group	PN ^{*)}	DN ^{*)}	Gatunek materiału ^{*)} Grade	T _{max} ^{*)}
ZAWÓR ZWROTNY ANTYSKAŻENIOWY TYP EA / ANTIPOLLUTION NON-RETURN VALVE TYPE EA					
1300	2	16	65 ÷ 200	EN-GJS-400-15	70 °C
ZAWÓR ZWROTNY ANTYSKAŻENIOWY TYP BA / ANTIPOLLUTION NON-RETURN VALVE TYPE BA					
1350	2	16	65 ÷ 250	EN-GJS-400-15	70 °C
ZASUWA NOŻOWA / KNIFE GATE VALVE					
ZASUWA NOŻOWA / KNIFE GATE VALVE					
2005, 2905	2	10	125 ÷ 400	EN-GJS-400-15 EN-GJS-500-7	70 °C / 120 °C
		6	500 ÷ 600		
		2,5	700 ÷ 1000		
ZASUWA NOŻOWA / KNIFE GATE VALVE					
2006, 2906	2	10	125 ÷ 400	EN-GJS-400-15 EN-GJS-500-7	70 °C / 120 °C
		6	500 ÷ 600		
		2,5	700 ÷ 1000		
ZASUWA KLINOWA / WEDGE GATE VALVE					
2109, 2509, 2909	2	10	125 ÷ 600	EN-GJS-500-7 EN-GJS-400-15	120 °C / 150 °C
	2	16	65 ÷ 600		
2110, 2510, 2910	2	10	125 ÷ 1000	EN-GJL-250 EN-GJS-400-15 EN-GJS-500-7	120 °C
	2	16	65 ÷ 1000		
2113, 2513, 2913	2	10	125 ÷ 300	EN-GJS-400-15 EN-GJS-500-7	120 °C
	2	16	65 ÷ 300		
ZASUWA KLINOWA Z TRZPIENIEM WZNOSZĄCYM / FLANGED GATE VALVE WITH RISING STEM					
2117, 2917	1	10	40 ÷ 600	EN-GJS-400-15, EN-GJS-500-7	150 °C
			600**		
		16	40 ÷ 600		
			600**		
ZASUWA KLINOWA MIĘKKOUSZCZELNIONA KOŁNIERZOWA / SOFT WEDGE GATE VALVE FLANGED					
2111, 2511, 2811, 2911, 2002, 2502, 2802, 2902, 2901, 2903	2	10	125 ÷ 1200	EN-GJS-400-15, EN-GJS-500-7	70 °C / 120 °C
	2	16	65 ÷ 1200		
	2	25	50 ÷ 500		
2112, 2512, 2812, 2912	2	10	125 ÷ 600	EN-GJS-400-15	70 °C / 120 °C
	2	16	65 ÷ 600		
2700, 2570, 2870, 2970	2	16	80 ÷ 300	EN-GJS-400-15	70 °C / 120 °C
ZASUWA MIĘKKOUSZCZELNIONA KIELICHOWA / FLANGED GATE VALVE WITH PIPE SOCKET					



NOTIFIED BODY
NO.1463

2115	2	16	65 + 200	EN-GJS-400-15	70 °C
ZASUWA MIĘKKOUSZCZELNIONA Z KRÓĆCAMI PE SOFT WEDGE GATE VALVE WITH PE PIPES					
2120	2	16	65 ÷ 300	EN-GJS-400-15	40 °C
ZASUWA MIĘKKOUSZCZELNIONA DO RUR PE / SOFT WEDGE GATE VALVE FOR PE PIPE					
2123	2	16	65 ÷ 300	EN-GJS-400-15	40 °C
ZASUWA MIĘKKOUSZCZELNIONA Z KRÓĆCAMI DO RUR ŻELIWNÝCH / FLANGED GATE VALVE WITH BUTTCAST IRON PIPES					
2125	2	16	65 ÷ 300	EN-GJS-400-15	70 °C
ZASUWA MIĘKKOUSZCZELNIONA Z TRZPIENIEM WZNOŚCĄCYM / SOFT WEDGE GATE VALVE WITH RISING STEM					
2217, 2218	2	10	125 + 600	EN-GJS-400-15, EN-GJS-500-7	70 °C / 120 °C
		16	65 ÷ 600		
		25	50 ÷ 300		
ZASUWA KLINOWA DO GAZU ZIEMNEGO / GATE VALVE INTENDED FOR NATURAL GAS					
2302, 2311, 2531, 2532, 2831, 2832, 2931, 2932	1	16	32 ÷ 600	EN-GJS-400-15, EN-GJS-350-22-LT	60 °C
ZASUWA MIĘKKOUSZCZELNIONA DO GAZU ZIEMNEGO Z KRÓĆCAMI PE / GATE VALVE INTENDED FOR NATURAL GAS WITH PE PIPES					
2312	1	10	32 ÷ 300	EN-GJS-400-15 EN-GJS-350-22-LT	40 °C
ZASUWA MIĘKKOUSZCZELNIONA Z KRÓĆCAMI STALOWYMI / SOFT WEDGE GATE VALVE WITH STEEL CONNECTOR					
2314	1	16	50 + 300	G20Mn5N G17Mn5	60 °C
PRZEPUSTNICA / BUTTERFLY VALVE					
4493	2	10	200 + 2000	EN-GJS-400-15 EN-GJS-500-7	70 °C / 120 °C
	2	16	200 ÷ 2000		
	2	25	200 ÷ 800		
4495	1	2	10	EN-GJS-400-15 EN-GJS-500-7	70 °C / 120 °C
	1	2	16		
4496	1	2	10	EN-GJS-400-15 EN-GJS-500-7	70 °C / 120 °C
	1	2	16		
4497	1	2	10	EN-GJS-400-15 EN-GJS-500-7	70 °C / 120 °C
	1	2	16		
4499	2	16	250 ÷ 800	EN-GJS-400-15 EN-GJS-500-7	70 °C / 120 °C
	2	25			
KUREK KULOWY PEŁNOPRZELOTOWY DO GAZU / BALL VALVE FULL BORE FOR NATURAL GAS					
5210	1	16	40-125	L360NB (1.0582) P355 (1.0562) S235JR (1.0037)	110 °C
		25	40-125		
		40	40-125		
		16	40-150	EN-GJS-400-15 EN-GJS-350-22-LT	
KUREK KULOWY PEŁNOPRZELOTOWY / BALL VALVE FULL BORE					
5220	2	16	65-125	L360NB (1.0582) P355 (1.0562) S235JR (1.0037)	160 °C
		25	50-125		
		40	40-125		
		16	65-150	EN-GJS-400-15	
		25	50-125	EN-GJS-350-22-LT	



KUREK KULOWY KOŁNIERZOWY Z ZANIŻONYM PRZELOTEM / BALL VALVE FLANGED REDUCED BORE					
5320	2	16	65-300	P265GH (1.0425)	160 °C
		25	50-300		
		40	40-50		
5321	2	16	65-300	P265GH (1.0425)	160 °C
		25	50-300		
		40	40-50		
KUREK KULOWY PEŁNOPRZELOTOWY / BALL VALVE FULL BORE					
ZAWÓR KULOWY ZWROTNY / BALL CHECK VALVE					
6516, 6526	2	10	125 ÷ 600	EN-GJS-400-15	70 °C / 120 °C
	2	16	65 ÷ 400		
FILTR SIATKOWY / STRAINER					
7110	2	10	125 ÷ 300	EN-GJL-250, EN-GJS 400-15	70 °C
		16	65 ÷ 300		
FILTR DO GAZU / GAS FILTER					
7310	1	10	32 ÷ 80	EN-GJS-350-22-LT	60 °C
		16			
7320	1	10	32 ÷ 80	EN-GJS-350-22-LT	60 °C
		16			

Uwagi / Notes:

*1) Dopuszczalne wersje wykonania (użyte materiały i średnice nominalne) w zależności od przewidzianych warunków pracy (ciśnienie robocze i temperatura pracy) określone są w odpowiednich kartach katalogowych.

Permissible versions of execution (used materials and nominal diameters) depend on the valve's working conditions (pressure and working temperature) are described in the relevant data sheets.

**1) Średnica nominalna DN600 - dopuszcza się wykonanie połączenia kołnierzowego i długość zabudowy jak dla DN700,

Nominal diameter DN600 - size of flanges and flange-to-flange dimension like for DN700,.



NOTIFIED BODY
NO.1463



AC 114

CERTYFIKAT OCENY SYSTEMU JAKOŚCI (MODUŁ H1) CERTIFICATE OF QUALITY SYSTEM ASSESSMENT (MODULE H1)

Nr
No. CW/PED/2/12/2020

Polski Rejestr Statków S.A. (PRS) zaświadcza, że zastosowany przez producenta system jakości w odniesieniu do projektu, wytwarzania, badania i odbioru końcowego zapewnia zgodność niżej wymienionych urządzeń ciśnieniowych z mającymi zastosowanie wymaganiami dyrektywy 2014/68/UE

Polski Rejestr Statków S.A. (PRS) hereby certifies that a quality system operated by the manufacturer for design, manufacture, testing and final inspection of the pressure equipment identified hereunder has been examined and found to satisfy the applicable provisions of the Directive 2014/68/EU.

Wnioskodawca
Applicant **Fabryka Armatur JAFAR SA**
ul. Kaydiego 12, 38-200 Jasło

Producent
Manufacturer **Fabryka Armatur JAFAR SA**
ul. Kaydiego 12, 38-200 Jasło

Inne miejsca produkcji
Other places of production ---

Opis urządzenia
Equipment description **Armatura przemysłowa**
Industrial valves

Wykaz produktów – patrz załącznik do certyfikatu
List of products – see appendix to certificate

Nr raportu z auditu
Audit report No. CW/PED/9/08/2020

Certyfikat jest ważny do
This certificate is valid until 2023.08.30



Zastępca Dyrektora Pionu Certyfikacji
Deputy Certification Division Director

Przemysław Gałka

Gdańsk, 2020.12.03



Nr jednostki notyfikowanej
No. of notified body

1463

Polski Rejestr Statków S.A.
al. Gen. Józefa Hallera 126
80-416 Gdańsk, Poland

Tel. (+48) (58) 346 17 00
fax (+48) (58) 341 77 69
e-mail: dc@prs.pl
www: <http://www.prs.pl/>

Wykaz produktów – patrz załącznik do certyfikatu CW/PED/2/12/2020.
List of products – see appendix to certificate CW/PED/2/12/2020.

ZAŁĄCZNIK DO CERTYFIKATU NR CW/PED/2/12/2020

ANNEX TO CERTIFICATE No. CW/PED/2/12/2020

WYKAZ ARMATURY OBJĘTEJ CERTYFIKATEM

LIST OF VALVES

Typ Type	Grupa płynów Fluid group	PN *)	DN *)	Gatunek materiału *) Grade	T _{max} *)
ZAWÓR ZWROTNY ANTYSKAŻENIOWY TYP EA / ANTIPOLLUTION NON-RETURN VALVE TYPE EA					
1300	2	16	65 ÷ 200	EN-GJS-400-15	70 °C
ZAWÓR ZWROTNY ANTYSKAŻENIOWY TYP BA / ANTIPOLLUTION NON-RETURN VALVE TYPE BA					
1350	2	16	65 ÷ 250	EN-GJS-400-15	70 °C
ZASUWA NOŻOWA / KNIFE GATE VALVE					
ZASUWA NOŻOWA / KNIFE GATE VALVE					
2005, 2905	2	10	125 ÷ 400	EN-GJS-400-15 EN-GJS-500-7	70 °C / 120 °C
		6	500 ÷ 600		
		2,5	700 ÷ 1000		
ZASUWA NOŻOWA / KNIFE GATE VALVE					
2006, 2906	2	10	125 ÷ 400	EN-GJS-400-15 EN-GJS-500-7	70 °C / 120 °C
		6	500 ÷ 600		
		2,5	700 ÷ 1000		
ZASUWA KLINOWA / WEDGE GATE VALVE					
2109, 2509, 2909	2	10	125 ÷ 600	EN-GJS-500-7 EN-GJS-400-15	120 °C / 150 °C
	2	16	65 ÷ 600		
2110, 2510, 2910	2	10	125 ÷ 1000	EN-GJL-250 EN-GJS-400-15 EN-GJS-500-7	120 °C
	2	16	65 ÷ 1000		
2113, 2513, 2913	2	10	125 ÷ 300	EN-GJL-250 EN-GJS-400-15 EN-GJS-500-7	120 °C
	2	16	65 ÷ 300		
ZASUWA KLINOWA Z TRZPIENIEM WZNOSZĄCYM / FLANGED GATE VALVE WITH RISING STEM					
2117, 2917	1	10	40 ÷ 600	EN-GJS-400-15, EN-GJS-500-7	150 °C
			600**		
		16	40 ÷ 600		
			600**		
ZASUWA KLINOWA MIĘKKOUSZCZELNIONA KOŁNIERZOWA / SOFT WEDGE GATE VALVE FLANGED					
2111, 2511, 2811, 2911, 2002, 2502, 2802, 2902, 2901, 2903	2	10	125 ÷ 1200	EN-GJS-400-15, EN-GJS-500-7	70 °C / 120 °C
	2	16	65 ÷ 1200		
	2	25	50 ÷ 500		
2112, 2512, 2812, 2912	2	10	125 ÷ 600	EN-GJS-400-15	70 °C / 120 °C
	2	16	65 ÷ 600		
2700, 2570, 2870, 2970	2	16	80 ÷ 300	EN-GJS-400-15	70 °C / 120 °C
ZASUWA MIĘKKOUSZCZELNIONA KIELICHOWA / FLANGED GATE VALVE WITH PIPE SOCKET					



2115	2	16	65 ÷ 200	EN-GJS-400-15	70 °C
ZASUWA MIĘKKOUSZCZELNIONA Z KRÓCCAMI PE SOFT WEDGE GATE VALVE WITH PE PIPES					
2120	2	16	65 ÷ 300	EN-GJS-400-15	40 °C
ZASUWA MIĘKKOUSZCZELNIONA DO RUR PE / SOFT WEDGE GATE VALVE FOR PE PIPE					
2123	2	16	65 ÷ 300	EN-GJS-400-15	40 °C
ZASUWA MIĘKKOUSZCZELNIONA Z KRÓCCAMI DO RUR ŻELIWNÝCH / FLANGED GATE VALVE WITH BUTTCAST IRON PIPES					
2125	2	16	65 ÷ 300	EN-GJS-400-15	70 °C
ZASUWA MIĘKOUSZCZELNIONA Z TRZPIENIEM WZNOŚĄCYM / SOFT WEDGE GATE VALVE WITH RISING STEM					
2217, 2218	2	10	125 ÷ 600	EN-GJS-400-15, EN-GJS-500-7	70 °C / 120 °C
		16	65 ÷ 600		
		25	50 ÷ 300		
ZASUWA KLINOWA DO GAZU ZIEMNEGO / GATE VALVE INTENDED FOR NATURAL GAS					
2302, 2311, 2531, 2532, 2831, 2832, 2931, 2932	1	16	32 ÷ 600	EN-GJS-400-15, EN-GJS-350-22-LT	60 °C
ZASUWA MIĘKKOUSZCZELNIONA DO GAZU ZIEMNEGO Z KRÓCCAMI PE / GATE VALVE INTENDED FOR NATURAL GAS WITH PE PIPES					
2312	1	10	32 ÷ 300	EN-GJS-400-15 EN-GJS-350-22-LT	40 °C
ZASUWA MIĘKKOUSZCZELNIONA Z KRÓCCAMI STALOWYMI / SOFT WEDGE GATE VALVE WITH STEEL CONNECTOR					
2314	1	16	50 ÷ 300	G20Mn5N G17Mn5	60 °C
PRZEPUSTNICA / BUTTERFLY VALVE					
4493	2	10	200 ÷ 2000	EN-GJS-400-15 EN-GJS-500-7	70 °C / 120 °C
	2	16	200 ÷ 2000		
	2	25	200 ÷ 800		
4495	1	2	10	EN-GJS-400-15 EN-GJS-500-7	70 °C / 120 °C
	1	2	16		
4496	1	2	10	EN-GJS-400-15 EN-GJS-500-7	70 °C / 120 °C
	1	2	16		
4497	1	2	10	EN-GJS-400-15 EN-GJS-500-7	70 °C / 120 °C
	1	2	16		
4499	2	16	250 ÷ 800	EN-GJS-400-15 EN-GJS-500-7	70 °C / 120 °C
	2	25			
KUREK KULOWY PEŁNOPRZELOTOWY DO GAZU / BALL VALVE FULL BORE FOR NATURAL GAS					
5210	1	16	40-125	L360NB (1.0582) P355 (1.0562) S235JR (1.0037)	110 °C
		25	40-125		
		40	40-125		
		16	40-150	EN-GJS-400-15 EN-GJS-350-22-LT	
KUREK KULOWY PEŁNOPRZELOTOWY / BALL VALVE FULL BORE					
5220	2	16	65-125	L360NB (1.0582) P355 (1.0562) S235JR (1.0037)	160 °C
		25	50-125		
		40	40-125		
		16	65-150	EN-GJS-400-15 EN-GJS-350-22-LT	
		25	50-125		



KUREK KULOWY KOŁNIERZOWY Z ZANIŻONYM PRZELOTEM / BALL VALVE FLANGED REDUCED BORE					
5320	2	16	65-300	P265GH (1.0425)	160 °C
		25	50-300		
		40	40-50		
5321	2	16	65-300	P265GH (1.0425)	160 °C
		25	50-300		
		40	40-50		
KUREK KULOWY PEŁNOPRZELOTOWY / BALL VALVE FULL BORE					
ZAWÓR KULOWY ZWROTNY / BALL CHECK VALVE					
6516, 6526	2	10	125 ÷ 600	EN-GJS-400-15	70 °C / 120 °C
	2	16	65 ÷ 400		
FILTR SIATKOWY / STRAINER					
7110	2	10	125 ÷ 300	EN-GJL-250, EN-GJS 400-15	70 °C
		16	65 ÷ 300		
FILTR DO GAZU / GAS FILTER					
7310	1	10	32 ÷ 80	EN-GJS-350-22-LT	60 °C
		16			
7320	1	10	32 ÷ 80	EN-GJS-350-22-LT	60 °C
		16			

Uwagi / Notes:

*) Dopuszczalne wersje wykonania (użyte materiały i średnice nominalne) w zależności od przewidzianych warunków pracy (ciśnienie robocze i temperatura pracy) określone są w odpowiednich kartach katalogowych.

Permissible versions of execution (used materials and nominal diameters) depend on the valve's working conditions (pressure and working temperature) are described in the relevant data sheets.

***) Średnica nominalna DN600 - dopuszcza się wykonanie połączenia kołnierzowego i długość zabudowy jak dla DN700,

Nominal diameter DN600 - size of flanges and flange-to-flange dimension like for DN700,.



