

# Rosemount™ 114C Thermowells



- Wide variety of industry standard process connections including flanged, threaded, welded, and Van Stone.
- Large selection of thermowell materials to ensure proper process compatibility from stainless steel to exotic materials such as duplex and alloy C-276.
- Additional thermowell options and certificates available.

---

**Contents**

Product overview .....	3	Rosemount 114C Van Stone Thermowells .....	33
Selection guide .....	5	Van Stone thermowell overview .....	34
Rosemount 114C Threaded Thermowells .....	6	Van Stone ordering information .....	36
Threaded thermowell overview .....	7	Van Stone thermowell drawings .....	44
Threaded ordering information .....	7	Rosemount 114C Welded Thermowells .....	46
Threaded thermowell drawings .....	16	Welded thermowell overview .....	47
Rosemount 114C Flanged Thermowells .....	18	Welded ordering information .....	49
Flanged thermowell overview .....	19	Weld-in Type 4 thermowells according to DIN 43772 .....	55
Flanged ordering information .....	21	Welded thermowell drawings .....	57
Flanged thermowell drawings .....	30	Ordering information detail .....	59

# Rosemount 114C Thermowell

## Product overview

Temperature sensors are rarely inserted directly into an industrial process. They are installed into a thermowell to isolate them from the potentially damaging process conditions of flow-induced stresses, high pressure, and corrosive chemical effects. Thermowells are closed-end metal tubes or barstock installed into the process vessel or piping and become an integral pressure-tight part of the process vessel or pipe. They permit the sensor to be quickly and easily removed from the process for calibration or replacement without requiring a process shutdown and possible drainage of the pipe or vessel.

The Rosemount 114C Thermowell is made from solid barstock to ensure strength and integrity. The Rosemount 114C was designed to accommodate a host of industry standard configurations, but has the flexibility to adapt to special configurations for different types of applications.

## Flexible design modifiers accommodate many process requirements

- Different sizes of root (A), tip (B), and bore (d) diameters
- Different tip (t) thickness as required
- Numerous combinations for various industrial applications
- Meet ASME PTC 19.3 TW standard with flexible design

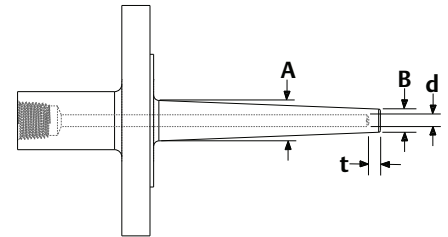

## Thermowell calculations ensure thermowell design is compatible with process conditions

- Thermowells inserted into any process are subjected to forces from the fluid flow.
- ASME released design standard PTC 19.3 TW that defines a series of qualitative calculations to determine design suitability to withstand process conditions.
- Calculations are based on process conditions, process fluid, installation method, thermowell geometry and material.
- The thermowell calculation tool from Emerson is designed to meet the ASME standard.
- The free online software version can be used for preliminary calculations. Click [here](#) to access the tool.
- Formal calculations by our expert team of engineers are available prior to order placement to ensure design is acceptable.
- Recommendations are also made if thermowell design is found to be unacceptable for the application.
- Order Thermowell Calculation option (R21) to receive a formal report with product shipment.

Figure 1. Thermowell Calculation Report (R21)

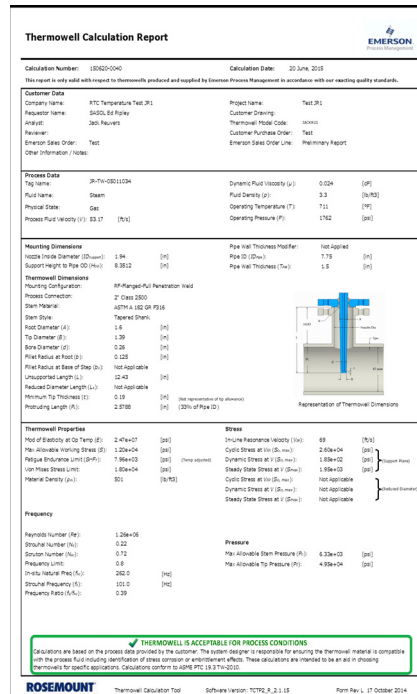

## Wide range of thermowell options and certificates for any application

- Options for special testing requirements, such as External Hydrostatic Pressure Test (Q5) and Dye Penetration Test (Q73)
- Options to ensure material traceability or compatibility, including Positive Material Identification or PMI (Q76), Material Certification (Q8), Thermowell X-ray/Radiograph (Q81), and NACE® Approval (Q35)
- Options for special processing requirements such as Electropolishing (R20)

## Experience global consistency and local support from numerous worldwide Emerson manufacturing sites

- World-class manufacturing provides globally consistent product from every factory and the capacity to fulfill the needs of any project, large or small.
- Experienced Instrumentation Consultants help select the right product for any temperature application and offer advice on best installation practices.
- An extensive global network of Emerson service and support personnel can be on-site when and where they are needed.



## Explore the benefits of a Complete Point Solution™ from Emerson

- An “Assemble Sensor to Specific Transmitter” and “Assemble Sensor to Specific Thermowell” option enables Emerson to provide a Complete Point Solution for measuring temperature, delivering an installation-ready transmitter, sensor, and thermowell assembly.
- Emerson has a complete portfolio of Single Point and Multi-Input Temperature Measurement solutions, allowing effective measurement and process control with reliable Rosemount products.

# Selection guide

## Ensure sensor fits thermowell

Rosemount 114C Head length (H) + Immersion length (U) = Rosemount 214C Sensor insertion length (L).

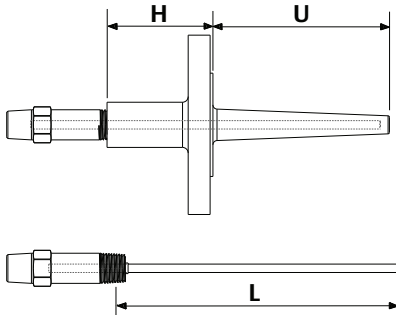

## Basic selection guide

Selecting the proper thermowell for an application is an important activity as it impacts plant safety and measurement efficiency. Thermowells are considered a wetted part; they physically become part of the pressure retaining system.

The four major factors to consider when selecting a thermowell for an application are described below:

### Thermowell length

There is no standard formula to determine thermowell immersion length. However, there are a few common practices that the process industry follows along with good engineering judgment. Ideally the thermowell tip should be located near the centerline in turbulent flow conditions because this represents the most accurate process temperature.

To ensure optimal performance, a general guideline for immersion length into a pipe is as follows:

- 10× the thermowell root diameter for air or gas
- 5× the thermowell root diameter for liquids

Another guideline is at least one-third the way into the pipe for any measurement. The American Petroleum Institute (API) has a specific recommendation of using an immersion length of the sensing element plus 50 mm (2-in.).

### Mounting configuration

Consider how the thermowell is mounted on the pipe or tank. The process designer typically specifies what mating connection will be used and the thermowell selected should match that connection. Temperature, pressure, and material are usually taken into consideration to ensure the process connection will be adequate for the application. Welded, threaded, flanged, and Van Stone are standard mounting configuration options.

### Thermowell stem profile

Factors to be considered when selecting a stem style include the process pressure, required response speed of the measurement, drag force of the fluid flow on the well, and the wake frequency. The stem or shank is the part of a thermowell inserted into the process piping or vessel. Straight, stepped and tapered stem styles are available. Each profile has its advantages depending on the need and situation.

### Thermowell material

Rosemount Thermowells are supplied in most materials required for industrial applications. Standard materials are 316/316L Stainless Steel, 304/304L Stainless Steel, and A105 Carbon Steel. For corrosive environments, special materials such as Alloy C-276 and Alloy 600 are also available. See the ordering table for a complete listing of standard materials. Contact your local Emerson representative for additional material availability.

## Rosemount 114C Threaded Thermowells



## Threaded thermowell overview

Threaded thermowells are threaded into a process pipe or tank, allowing for easy installation and removal when necessary. While this is a common mounting method, it has the lowest pressure rating of all mounting configuration options.

**Figure 2. Standard Offering–Threaded**

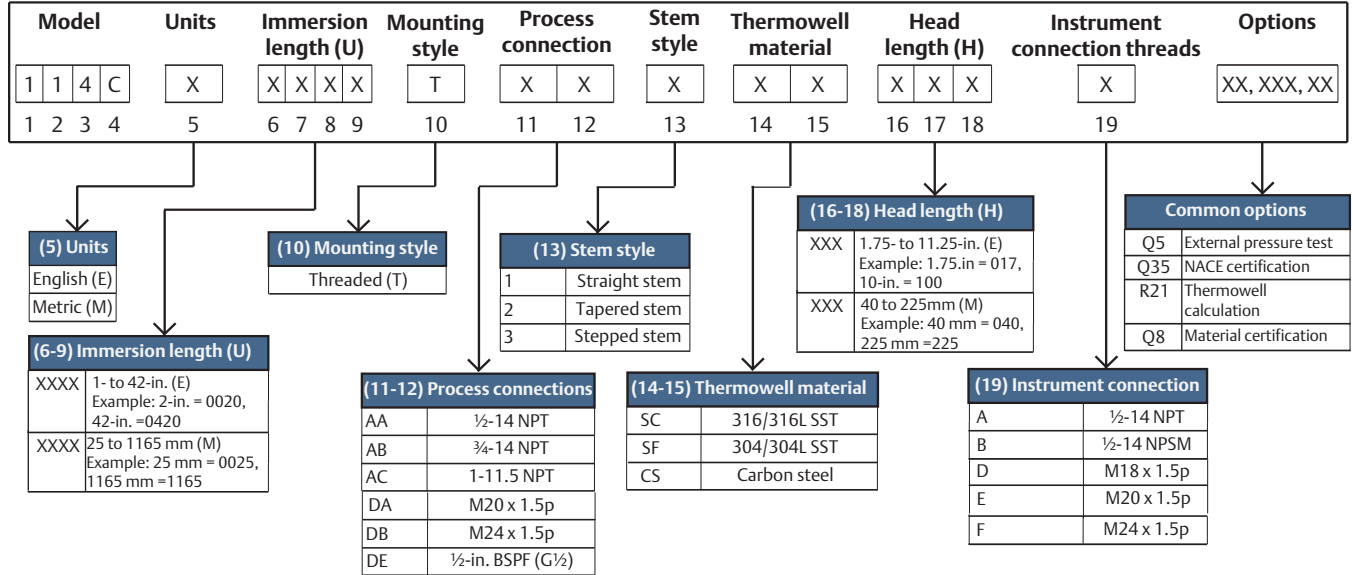

The common options shown in Figure 2 represent a partial offering; reference the [Rosemount 114C Threaded Ordering Information](#) for a full list of available options.

**Figure 3. Threaded Thermowell Components**

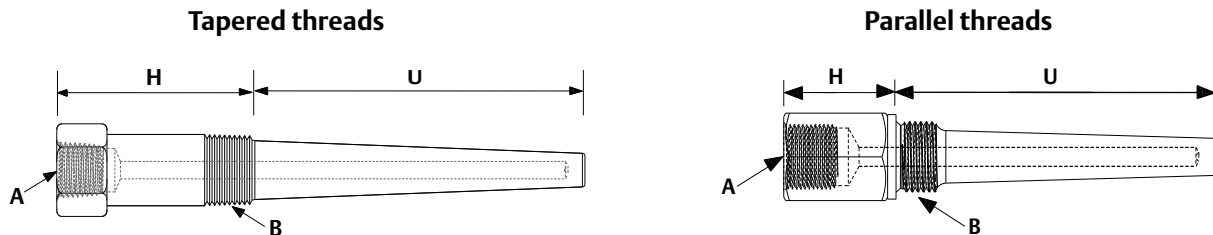

A. Instrument connection  
B. Process connection

H. Head length  
U. Immersion length

**Note**

Wetted surface includes engaged threads and immersion length (U).

Use the form below to record your model code:

Model				Units	Immersion length (U)	Mounting style	Process connection	Stem style	Thermowell material	Head length (H)	Instrument connection	Options
1	1	4	C			T						
1	2	3	4	5	6 through 9	10	11 and 12	13	14 and 15	16 through 18	19	XXXXX



## Threaded ordering information

Figure 4. Model Number Ordering Example

Model				Units	Immersion length (U)				Mounting style	Process connection		Stem style	Thermowell material		Head length (H)			Instrument connection	Options
1	1	4	C	E	0	0	6	0	T	A	A	1	S	C	0	5	0	A	WR5, Q76...
1	2	3	4	5	6	7	8	9	10	11	12	13	14	15	16	17	18	19	XXXXX

The numbers below the model number ordering example correlate to the character place numbers in the second column of the ordering table.

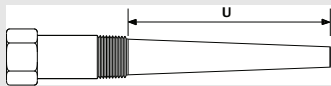
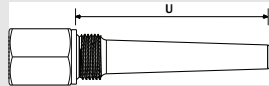
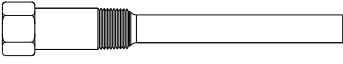

Table 1. Rosemount 114C Threaded Ordering Information

The starred offerings (★) represent the most common options and should be selected for best delivery. The non-starred offerings are subject to additional delivery lead time.

Place #s 1-4	Model	Details		Ref. page
★ 114C	Barstock temperature thermowell	Made with a standard bore diameter of 0.26-in. (6.6 mm) and tip wall thickness of 0.25-in. (6.4 mm)		N/A
Place # 5	Dimension units			Ref. page
★ E	English units (in.)	Specifies whether length units will be in inches (in.) or millimeters (mm)		59
★ M	Metric units (mm)			59
Place #s 6-9	Immersion length (U)	Tapered threads	Parallel threads	Ref. page
				
★ xxxx	xxx.x-in., 1.00 to 100-in. in 1/4-in. increments (when ordered with dimension units code E) Example of a 6.25-in. length where the second decimal is dropped off: 0062			59
★ xxxx	xxxx mm, 25 to 2500 mm in 5 mm increments (when ordered with dimension units code M) Example of a 50 mm length: 0050			59
Place # 10	Mounting style			Ref. page
★ T	Threaded			N/A
Place #s 11-12	Process connection			Ref. page
★ AA	1/2-14 NPT	Tapered threads		N/A
★ AB	3/4-14 NPT	Tapered threads		N/A
★ AC	1-11.5 NPT	Tapered threads		N/A
★ AD	1 1/2-11.5 NPT	Tapered threads		N/A
★ AE	1/2-in. BSPT	Tapered threads		N/A

**Table 1. Rosemount 114C Threaded Ordering Information**

The starred offerings (★) represent the most common options and should be selected for best delivery. The non-starred offerings are subject to additional delivery lead time.

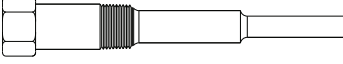
★	AF	3/4-in. BSPT	Tapered threads	N/A	
★	AG	1-in. BSPT	Tapered threads	N/A	
★	DA	M20 × 1.5p	Parallel threads	N/A	
★	DB	M24 × 1.5p	Parallel threads	N/A	
★	DC	M27 × 2p	Parallel threads	N/A	
	DD	M33 × 2p	Parallel threads	N/A	
★	DE	1/2-in. BSPF (G <sup>1/2</sup> )	Parallel threads	N/A	
★	DF	3/4-in. BSPF (G <sup>3/4</sup> )	Parallel threads	N/A	
★	DG	1-in. BSPF (G1)	Parallel threads	N/A	
<b>Place # 13</b>		<b>Stem style</b>	<b>Details</b>	<b>Image</b>	<b>Ref. page</b>
★	1	Straight	Minimum immersion length 1-in. (25 mm) - Tapered threads 1.75-in. (45 mm) - Parallel threads		60
★	2	Tapered	Minimum immersion length 1-in. (25 mm) - Tapered threads 1.75-in. (45 mm) - Parallel threads		60
★	3	Stepped	Minimum immersion length 3-in. (75 mm) - Tapered threads 3.75-in. (95 mm) - Parallel threads		60
<b>Place #s 14-15</b>		<b>Thermowell material</b>	<b>Details</b>		<b>Ref. page</b>
★	SC	316/316L dual rated			61
	SD	316/316L dual rated (NORSOK)	Must order the Q8 Material Certificate to get NORSOK documentation		62
★	SF	304/304L dual rated			61
★	CS	Carbon steel (A-105)			61
	SG	316Ti SST			61
	SL	310 SST			61
	SM	321 SST			61
	SN	321H SST			61
	SR	904L SST			61
	SP	347 SST			61
	AB	Alloy B3			61
	AC	Alloy C-276			61
	AG	Alloy 20			62
	AH	Alloy 400			61
	AK	Alloy 600			61

**Table 1. Rosemount 114C Threaded Ordering Information**

The starred offerings (★) represent the most common options and should be selected for best delivery. The non-starred offerings are subject to additional delivery lead time.

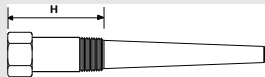
AM	Alloy 601		61	
AN	Alloy 625		61	
AP	Alloy 800		61	
AQ	Alloy 800H/HT		61	
AR	Alloy 825		61	
AU	Alloy C-202		61	
AS	Alloy F44 Mo6		61	
MO	Molybdenum		61	
CA	Chrome-Moly Grade B-11/F-11 Class II		61	
CB	Chrome-Moly Grade B-22/ F-22 Class III		61	
CC	Chrome-Moly Grade F-91		61	
NK	Nickel 200		61	
TT	Titanium Grade 2		61	
DS	Super duplex SST Grade F-53		61	
DT	Super duplex SST Grade F-53 – NORSOK	Must order the Q8 Material Certificate to get NORSOK documentation	62	
DU	Duplex 2205 Grade F51		61	
DV	Duplex 2205 Grade F51 – NORSOK	Must order the Q8 Material Certificate to get NORSOK documentation	62	
Place # 16-18	Head length (H)	<b>Tapered threads</b>	<b>Parallel threads</b>	<b>Ref. page</b>
				
★ xxx	xx.x-in., 1.75 to 11.25-in. in 1/4-in. increments (when ordered with dimension units code E)		63	
	Example of a 6.25-in. length where the second decimal is dropped off: 062 (default head length = 1.75-in.)			
★ xxx	xxx mm, 40 to 225 mm in 5 mm increments (when ordered with dimension units code M)		63	
	Example of a 50 mm length: 050 (default head length = 45 mm)			

**Table 1. Rosemount 114C Threaded Ordering Information**

The starred offerings (★) represent the most common options and should be selected for best delivery. The non-starred offerings are subject to additional delivery lead time.

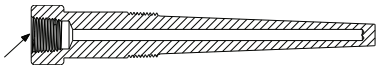
Place # 19	Instrument connection	Details	Image	Ref. page
★ A	1/2-14 NPT	Female threads		64
★ B	1/2-14 NPSM			64
C	3/4-14 NPT			64
D	M18 × 1.5p			64
E	M20 × 1.5p			64
F	M24 × 1.5p			64
G	G 1/2-in. (BSPF)			64
H	G 3/4-in. (BSPF)			64
J	M27 × 2p			64
K	M14 × 1.5p			64

**Options (include with selected model number)**

Sensor/thermowell assemble to options		Details	Ref. page
★ XT	Hand tight assembly of sensor and thermowell	Ensures sensor is threaded into thermowell but only hand tightened	65
★ XW	Process-ready assembly of sensor and thermowell	Ensures sensor is threaded into thermowell and torqued for process-ready installation	65
<b>Extended product warranty</b>			<b>Ref. page</b>
★ WR3	3-year limited warranty	This warranty option extends manufacturer’s warranty to three or five years for manufacturer related defects	65
★ WR5	5-year limited warranty		65
<b>Thermowell calculation</b>			<b>Ref. page</b>
★ R21	Thermowell calculation	Set of calculations to ensure thermowells are safe in certain process conditions	65
<b>NACE certification</b>			<b>Ref. page</b>
★ Q35	NACE certification	Meets MR0175/ISO 15156 and MR0103 requirements	66
<b>PMI testing</b>			<b>Ref. page</b>
Q76	PMI testing	Verifies chemical composition of material	66
<b>Material certification</b>			<b>Ref. page</b>
★ Q8	Material certification	Certificate for material conformance and traceability in accordance with EN 10204 type 3.1	67

**Table 1. Rosemount 114C Threaded Ordering Information**

The starred offerings (★) represent the most common options and should be selected for best delivery. The non-starred offerings are subject to additional delivery lead time.

<b>Material tests</b>				<b>Ref. page</b>
	M01	Low temperature Charpy Test	Measures the low temperature ductility of the material	67
	M02	Ultrasonic material test	Examination of steel forgings for flaws and inclusions	67
<b>Surface finish</b>			<b>Details</b>	<b>Ref. page</b>
	Q16	Certification	Certificate showing measured surface finish values	68
	R14	Finish < Ra 0.3 μm (12 μin)	Improves surface roughness of thermowell	68
<b>Electropolish</b>				<b>Ref. page</b>
	R20	Electropolish	Improve smoothness and surface quality	68
<b>Hydrostatic external pressure test</b>				<b>Ref. page</b>
★	Q5	Standard external pressure test	Verifies structural quality and checks for leaks at thermowell process connection and stem	68
★	Q9	Extended external pressure test	Same as standard external pressure test but tested twice as long	69
<b>Hydrostatic internal pressure test</b>				<b>Ref. page</b>
★	Q85	Standard internal pressure test	Verify internal structural integrity of thermowell	69
★	Q86	Extended internal pressure test	Same as standard internal pressure test but tested twice as long	70
<b>Canadian Registration Number</b>				<b>Ref. page</b>
	Q17	Canadian Registration Number	Canadian approvals for all provinces (Approved materials in reference section)	70
<b>Dye penetration test</b>				<b>Ref. page</b>
★	Q73	Dye penetration test	Checks quality of material	70
<b>Wall thickness test</b>				<b>Ref. page</b>
	Q83	Ultrasonic test	Checks the bore concentricity of the thermowell	71
	Q84	Radiography (X-ray) test	Checks the bore concentricity of the thermowell	72
<b>Special cleaning</b>				<b>Ref. page</b>
	Q6	Special cleaning	Oxygen enriched environment cleaning per ASTM G93	71
<b>Thermowell markings</b>				<b>Ref. page</b>
	R40	Test markings on thermowell	External marking of the thermowell for specific tests (see reference page for list of tests)	71

**Table 1. Rosemount 114C Threaded Ordering Information**

The starred offerings (★) represent the most common options and should be selected for best delivery. The non-starred offerings are subject to additional delivery lead time.

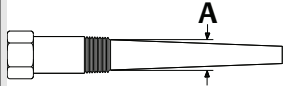
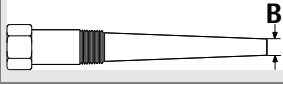
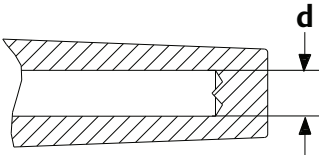
Plug and chain				Ref. page
R06	Stainless steel	Protects thermowell threads when sensor is not installed		73
R23	Brass	Protects thermowell threads when sensor is not installed		73
Spherical tip				Ref. page
R60	Spherical tip	Changes the flat tip to spherical		72
Vent hole				Ref. page
R11	Vent hole	Allows for the venting of a thermowell and for indication that thermowell structural integrity has been compromised		73
Thermowells with wrench flats				Ref. page
R37	Thermowells with wrench flats	Converts the two wrench flats to hex wrench flats; only applies to exotic materials		79
Root diameter (A)				Ref. page
Axxx	x.xx-in., 0.36 to 3.15-in. in 0.01-in. increments (when ordered with dimension units code E)			80
	Examples: Code A040 = 0.4-in., Code A315 = 3.15-in.			
Axxx	xx.xx mm, 10 to 80 mm in 0.5 mm increments (when ordered with dimension units code M)			80
	Examples: Code A100 = 10.0 mm, Code A755 = 75.5 mm			
Tip diameter (B)				Ref. page
Bxxx	x.xx-in., 0.36 to 1.83-in. in 0.01-in. increments (when ordered with dimension units code E)			81
	Examples: Code B040 = 0.4-in., Code B180 = 1.80-in.			
Bxxx	xx.xx mm, 10 to 46 mm in 0.5-mm. increments (when ordered with dimension units code M)			81
	Examples: Code B100 = 10.0 mm, Code B455 = 45.5 mm			
Non-standard bore diameter (d)		Details	Image	Ref. page
D01	0.276-in./7.0 mm	Default = 0.26-in. (6.6 mm)		82
D03	0.138-in./3.5 mm			82
D04	0.386-in./9.8 mm			82
D05	0.354-in./9.0 mm			82
D06	0.433-in./11.0 mm			82

**Table 1. Rosemount 114C Threaded Ordering Information**

The starred offerings (★) represent the most common options and should be selected for best delivery. The non-starred offerings are subject to additional delivery lead time.

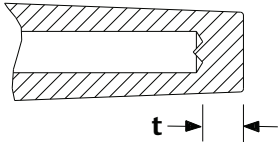
Non-standard tip thickness (t)				Ref. page
T01	0.197-in./5.0 mm	Default = 0.25-in. (6.4 mm)		82
T02	0.236-in./6.0 mm			82

**Threaded installation**

Threaded thermowells are screwed into the process using a threaded fitting or directly into a tapped pipe if there is sufficient wall thickness. Tapered threads will deform to each other to create a seal. Thread sealant and appropriate torque should be applied to reduce risk of leaks.

**Figure 5. Installation Components**

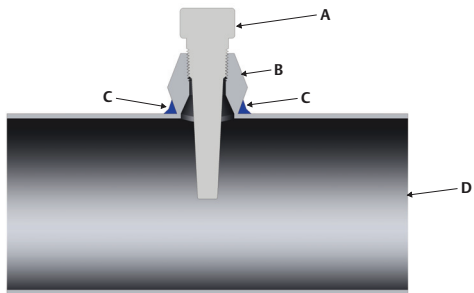

- A. Thermowell
- B. Threaded fitting
- C. Weld
- D. Process

## Threaded thermowell drawings

Figure 6. Thread Mount Thermowell Drawings (Tapered Thread)<sup>(1)</sup>

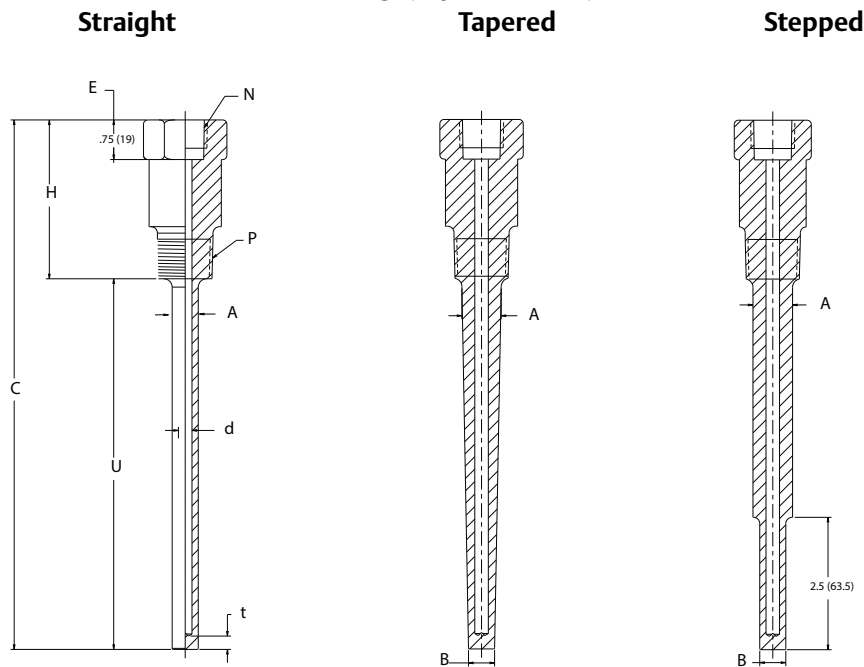

A. Root diameter  
 B. Tip diameter  
 C. Total length (U + H)  
 E. Wrench allowance  
 F. Thread allowance  
 H. Head length

N. Instrument connection  
 P. Process connection  
 U. Immersion length  
 d. Bore diameter  
 t. Tip thickness

Table 2. Thread Mount Thermowells (Tapered Thread)<sup>(1)</sup>

Code	Code T, threaded mounting style	Wrench flat size "C"		Root diameter stepped stem	Root diameter tapered stem	Tip diameter tapered stem	Root diameter straight stem	Thread specification
		Metric units (code M)	English units (code E)					
AA	1/2-14 NPT	1.18 (30)	1 1/8 (28.6)	0.67 (17)	0.67 (17)	0.50 (12.7)	0.669 (17)	NPT per SAE-AS 71051 (reference PS-71)
AB	3/4-14 NPT	1.18 (30)	1 1/8 (28.6)	0.75 (19)	0.89 (22.5)	0.63 (16)	0.71 (18)	
AC	1-11.5 NPT	1.34 (34)	1 1/4 (31.8)	0.85 (21.5)	1.04 (26.5)	0.71 (18)	0.71 (18)	
AD	1 1/2-11.5 NPT	1.89 (48)	1 3/4 (44.5)	0.85 (21.5)	1.04 (26.5)	0.71 (18)	0.71 (18)	
AE	1/2-in. BSPT	1.18 (30)	1 1/8 (28.6)	0.67 (17)	0.67 (17)	0.50 (12.7)	0.669 (17)	THD per ISO 7/1 (BS 21)
AF	3/4-in. BSPT	1.18 (30)	1 1/8 (28.6)	0.75 (19)	0.89 (22.5)	0.63 (16)	0.71 (18)	
AG	1-in. BSPT	1.34 (34)	1 1/4 (31.8)	0.85 (21.5)	1.04 (26.5)	0.71 (18)	0.71 (18)	

1. Dimensions are in inches (millimeters).

1. Total length = U+ H.



Figure 7. Thread Mount Thermowell Drawings (Parallel Thread)<sup>(1)</sup>

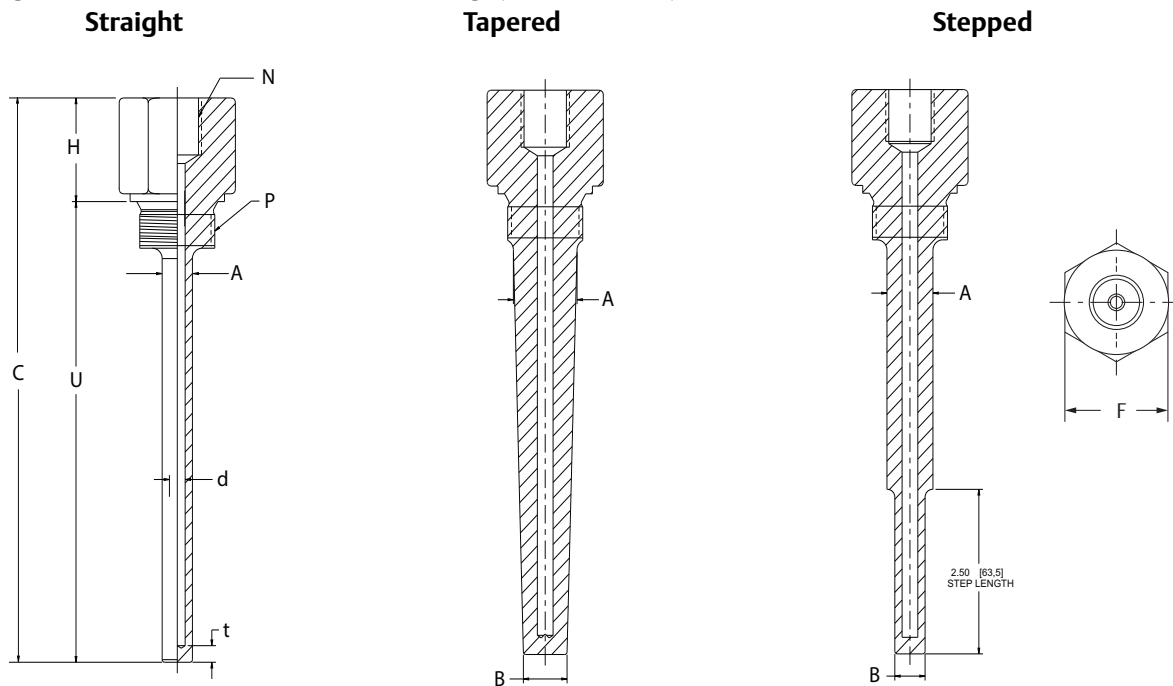

- A. Root diameter
- B. Tip diameter
- C. Total length (U + H)
- F. Hex size
- H. Head length
- N. Instrument connection
- P. Process connection
- U. Immersion length
- d. Bore diameter
- t. Tip thickness

Table 3. Thread Mount Thermowells (Parallel Thread)<sup>(1)</sup>

Code	Code T, threaded mounting style	Hex size "F"	Root diameter stepped stem	Root diameter tapered stem	Tip diameter tapered stem and straight stem	Thread specification
	Process connection "P"					
DA	M20 × 1.5	1.18 (30)	0.67 (17)	0.67 (17)	0.5 (12.7)	Thread per BS3643
DB	M24 × 1.5	1.18 (30)	0.75 (19)	0.75 (19)	0.5 (12.7)	
DC	M27 × 2	1.26 or 1.42 (32 or 36)	0.75 (19)	0.75 (19)	0.5 (12.7)	
DD	M33 × 2	1.61 (41)	0.85 (21.5)	1.04 (26.5)	0.71 (18)	
DE	1/2-in. BSPF (G1/2)	1.06 (27)	0.67 (17)	0.67 (17)	0.5 (12.7)	Thread per ISO 228/1 (BS 2779)
DF	3/4-in. BSPF (G3/4)	1.26 (32)	0.75 (19)	0.75 (19)	0.5 (12.7)	
DG	1-in. BSPF (G1)	1.61 (41)	0.85 (21.5)	1.04 (26.5)	0.71 (18)	

1. Dimensions are in inches (millimeters).

**Note**

Hex size will be different depending on units selected (english and metric).  
 Wrench flats are used on exotic materials instead of hex flats. For hex flats on exotic materials, select option R37.  
 Additional root and tip diameters available.

1. Total length = U+ H.

## Rosemount 114C Flanged Thermowells

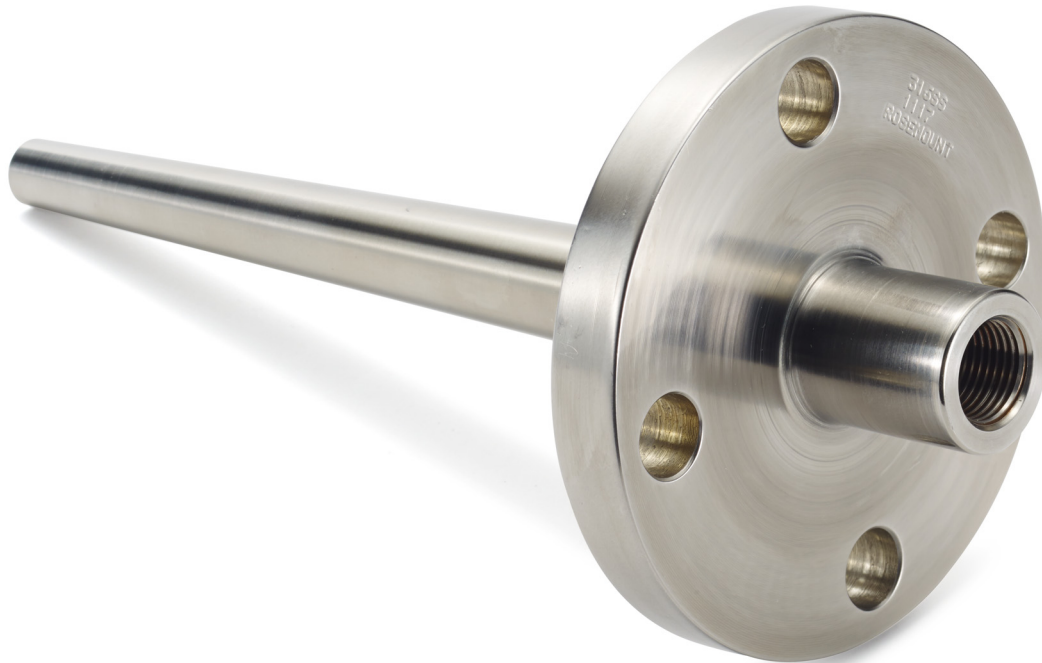

## Flanged thermowell overview

All Rosemount flanged thermowells are manufactured in accordance with ANSI B16.5. The flange to stem weld is in accordance to ASME Section IX. There is also full traceability with material certifications available on request. Rosemount flanged thermowells are available in two manufacturing configurations: full and partial penetration welds.

### Full penetration weld (F)

- Stronger weld joint per ASME PTC 19.3 TW
- Used for heavy duty applications
- Emerson recommended option

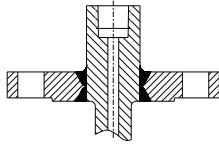

### Partial penetration weld (P)

- Adequate for most process applications
- Weld withstands same pressure and temperature rating as flange
- Lower cost than full penetration weld

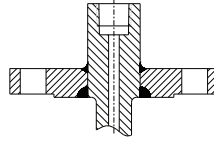

### Forged, no welds (G)

- Highest fatigue resistance per ASME PTC 19.3 TW
- Eliminates weld qualifications and failures
- Used in extreme process applications

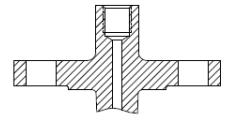

Figure 8. Standard Offering–Flanged

Model	Units	Immersion length (U)	Mounting style	Process connection	Stem style	Thermowell material	Head length (H)	Instrument connection threads	Options
1 1 4 C	X	X X X X	X	X X	X	X X	X X X	X	XX, XXX, XX
1 2 3 4	5	6 7 8 9	10	11 12	13	14 15	16 17 18	19	

<b>(5) Units</b>		<b>(10) Mounting style</b>		<b>(13) Stem style</b>		<b>(16-18) Head length (H)</b>		<b>Common options</b>	
English (E)		F Full penetration weld		1 Straight stem		XXX 2.25in to 11.25in (E) Example: 2.25in=022, 10in=100		Q5 External pressure test	
Metric (M)		P Partial penetration weld		2 Tapered stem		XXX 40mm to 225mm (M) Example: 40mm=040, 225mm=225		Q35 NACE certification	
		G Forged, no welds		3 Stepped stem				R21 Wake frequency calculation	
<b>(6-9) Immersion length (U)</b>		<b>(11-12) Process connections</b>		<b>(14-15) Thermowell material</b>		<b>(19) Instrument connection</b>			
XXXX 0.5in to 42in (E) Example: 0.5in=0005, 42in=0420		AA 1-in. Class 150		SC 316/316L SST		A ½-14 NPT		Q8 Material certification	
XXXX 25mm to 1165mm (M) Example: 25mm=0025, 1165mm=1165		AB 1½-in. Class 150		SF 304/304L SST		B ½-14 NPSM		Q73 Dye penetration test	
		AC 2-in. Class 150		CS Carbon steel		D M18 x 1.5p			
		AH 1-in. Class 300				E M20 x 1.5p			
		AJ 1½-in. Class 300				F M24 x 1.5p			
		AK 2-in. Class 300							

The common options shown in Figure 8 represent a partial offering; reference the Rosemount 114C Flanged Ordering Information for a full list of available options.

Figure 9. Flanged Thermowell Components

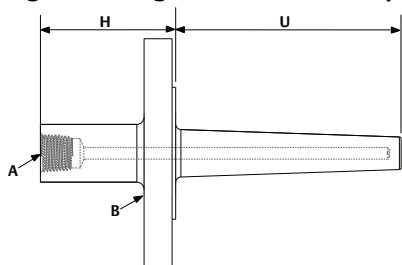

A. Instrument connection  
B. Process connection

H. Head length  
U. Immersion length

**Note**

Wetted surface includes flange face and immersion length (U).

Use the form below to record your model code:

Model				Units	Immersion length (U)	Mounting style	Process connection	Stem style	Thermowell material	Head length (H)	Instrument connection	Options
1	1	4	C									
1	2	3	4	5	6 through 9	10	11 and 12	13	14 and 15	16 through 18	19	XXXXX

## Flanged ordering information

**Figure 10. Model Number Ordering Example**

Model				Units	Immersion length (U)				Mounting style	Process connection		Stem style	Thermowell material		Head length (H)			Instrument connection	Options
1	1	4	C	E	0	1	5	0	F	A	C	1	S	C	0	5	0	A	WR5, Q76...
1	2	3	4	5	6	7	8	9	10	11	12	13	14	15	16	17	18	19	XXXXX

The numbers below the model number ordering example correlate to the character place numbers in the second column of the ordering table.

**Table 4. Rosemount 114C Flanged Ordering Information**

The starred offerings (★) represent the most common options and should be selected for best delivery. The non-starred offerings are subject to additional delivery lead time.

Place #s 1-4	Model	Details	Ref. page
★ 114C	Barstock temperature thermowell	Made with a standard bore diameter of 0.26-in. (6.6 mm) and tip wall thickness of 0.25-in. (6.4 mm). Default ASME flange facing is raised face with spiral serrations. Default EN 1092-1 flange facing is raised face Type B1.	N/A
Place # 5	Dimension units		Ref. page
★ E	English units (in.)	Specifies whether length units will be in inches (in) or millimeters (mm)	59
★ M	Metric units (mm)		59
Place # 6-9	Immersion length (U)		Ref. page
★ xxxx	xx.x-in., 1 to 100-in. in 1/4-in. increments (when ordered with dimension units code E) Example of a 6.25-in. length where the second decimal is dropped off: 0062		59
★ xxxx	xxxx mm, 25 to 2500 mm in 5 mm increments (when ordered with dimension units code M) Example of a 25 mm length: 0025		59
Place # 10	Mounting style		Ref. page
★ P	Flange, partial penetration weld	Weld refers to welding of the flange to thermowell stem	N/A
★ F	Flange, full penetration weld		N/A
G	Flange, forged	Single piece forging, no welds	N/A

Table 4. Rosemount 114C Flanged Ordering Information

The starred offerings (★) represent the most common options and should be selected for best delivery. The non-starred offerings are subject to additional delivery lead time.

Place # 11-12	Process connection	Details		Ref. page
		Partial weld (P)	Full penetration weld (F)	
★ AA	1-in. Class 150	1-in. Class 150	1-in. Class 150	N/A
★ AB	1½-in. Class 150	1½-in. Class 150	1½-in. Class 150	N/A
★ AC	2-in. Class 150	2-in. Class 150	2-in. Class 150	N/A
★ AD	3-in. Class 150	3-in. Class 150	3-in. Class 150	N/A
★ AE	4-in. Class 150	4-in. Class 150	4-in. Class 150	N/A
★ AF	6-in. Class 150	6-in. Class 150	6-in. Class 150	N/A
★ AG	¾-in. Class 300	¾-in. Class 300	¾-in. Class 300	N/A
★ AH	1-in. Class 300	1-in. Class 300	1-in. Class 300	N/A
★ AJ	1½-in. Class 300	1½-in. Class 300	1½-in. Class 300	N/A
★ AK	2-in. Class 300	2-in. Class 300	2-in. Class 300	N/A
AL	1-in. Class 400/600	1-in. Class 400/600	1-in. Class 400/600	N/A
AM	1½-in. Class 400/600	1½-in. Class 400/600	1½-in. Class 400/600	N/A
AN	2-in. Class 400/600	2-in. Class 400/600	2-in. Class 400/600	N/A
AP	N/A	1-in. Class 900/1500	1-in. Class 900/1500	N/A
AQ	N/A	1½-in. Class 900/1500	1½-in. Class 900/1500	N/A
AR	N/A	2-in. Class 900/1500	2-in. Class 900/1500	N/A
AT	N/A	1½-in. Class 2500	1½-in. Class 2500	N/A
AU	N/A	2-in. Class 2500	2-in. Class 2500	N/A
AV	3-in. Class 300	3-in. Class 300	3-in. Class 300	N/A
FA	DN 20/PN 2.5/6	DN 20/PN 2.5/6	N/A	N/A
FE	DN 20/PN 10/16/25/40	DN 20/PN 10/16/25/40	N/A	N/A
FG	DN 20/PN 63/100	DN 20/PN 63/100	N/A	N/A
GA	DN 25/PN 2.5/6	DN 25/PN 2.5/6	N/A	N/A
GE	DN 25/PN 10/16/25/40	DN 25/PN 10/16/25/40	N/A	N/A
GG	DN 25/PN 63/100	DN 25/PN 63/100	N/A	N/A
JA	DN 40/PN 2.5/6	DN 40/PN 2.5/6	N/A	N/A
JE	DN 40/PN 10/16/25/40	DN 40/PN 10/16/25/40	N/A	N/A
JG	DN 40/PN 63/100	DN 40/PN 63/100	N/A	N/A
KA	DN 50/PN 2.5/6	DN 50/PN 2.5/6	N/A	N/A
KC	DN 50/PN 10/16	DN 50/PN 10/16	N/A	N/A
KE	DN 50/PN 25/40	DN 50/PN 25/40	N/A	N/A
KF	DN 50/PN 63	DN 50/PN 63	N/A	N/A

**Table 4. Rosemount 114C Flanged Ordering Information**

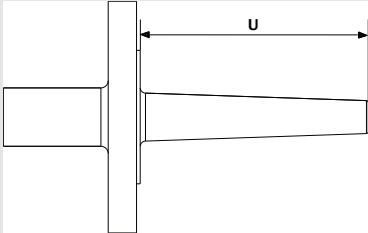
The starred offerings (★) represent the most common options and should be selected for best delivery. The non-starred offerings are subject to additional delivery lead time.

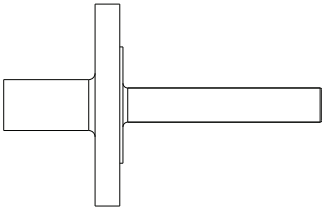
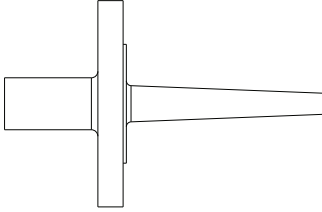
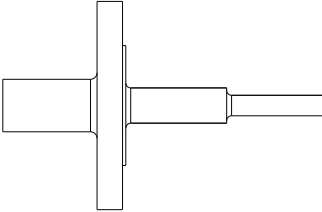
Place # 11-12	Process connection	Details		Ref. page
		Partial weld (P)	Full penetration weld (F)	
KG	DN 50/PN 100	DN 50/PN 100	N/A	N/A
LA	DN 65/PN 2.5/6	DN 65/PN 2.5/6	N/A	N/A
LC	DN 65/PN 10/16	DN 65/PN 10/16	N/A	N/A
LE	DN 65/PN 24/40	DN 65/PN 24/40	N/A	N/A
LF	DN 65/PN 63	DN 65/PN 63	N/A	N/A
LG	DN 65/PN 100	DN 65/PN 100	N/A	N/A
MA	DN 80/PN 2.5/6	DN 80/PN 2.5/6	N/A	N/A
MC	DN 80/PN 10/16	DN 80/PN 10/16	N/A	N/A
ME	DN 80/PN 25/40	DN 80/PN 25/40	N/A	N/A
MF	DN 80/PN 63	DN 80/PN 63	N/A	N/A
MG	DN 80/PN 100	DN 80/PN 100	N/A	N/A
NA	DN 100/PN 2.5/6	DN 100/PN 2.5/6	N/A	N/A
NC	DN 100/PN 10/16	DN 100/PN 10/16	N/A	N/A
NE	DN 100/PN 25/40	DN 100/PN 25/40	N/A	N/A
NF	DN 100/PN 63	DN 100/PN 63	N/A	N/A
NG	DN 100/PN 100	DN 100/PN 100	N/A	N/A
Place # 13	Stem style	Details	Image	Ref. page
★ 1	Straight	Minimum immersion length = 1-in. (25 mm)		60
★ 2	Tapered	Minimum immersion length = 1-in. (25 mm)		60
★ 3	Stepped	Minimum immersion length = 3-in. (75 mm)		60

**Table 4. Rosemount 114C Flanged Ordering Information**

The starred offerings (★) represent the most common options and should be selected for best delivery. The non-starred offerings are subject to additional delivery lead time.

Place #s 14-15	Thermowell material	Details	Ref. page
★ SC	316/316L dual rated		61
SD	316/316L dual rated (NORSOK)	Must order the Q8 Material Certificate to get NORSOK documentation	62
★ SF	304/304L dual rated		61
★ CS	Carbon steel (A-105)		61
SG	316Ti SST		61
SH	316/316L SST with tantalum sheath	Only available as a straight stem profile with a 0.75 diameter thus requires option A075 for English units	62
SJ	316/316L SST with PFA coating		61
SK	304/304L SST with PTFE coating		61
SL	310 SST		61
SM	321 SST		61
SN	321H SST		61
SR	904L SST		61
SP	347 SST		61
AB	Alloy B3		61
AC	Alloy C-276		61
AD	Alloy C-4 (with 304/304L SST flange)	Not available with G (Fully forged) mounting style	61
AE	Alloy C-22 (with 304/304L SST flange)	Not available with G (Fully forged) mounting style	61
AF	Alloy C-22 (with 316/316L SST flange)	Not available with G (Fully forged) mounting style	61
AG	Alloy 20		61
AH	Alloy 400		61
AJ	Alloy 400 (with 304/304L SST flange)	Not available with G (Fully forged) mounting style	61
AK	Alloy 600		61
AL	Alloy 600 (with 304/304L SST flange)	Not available with G (Fully forge) mounting style	61
AM	Alloy 601		61
AN	Alloy 625		61
AP	Alloy 800		61
AQ	Alloy 800H/HT		61
AR	Alloy 825		61
AU	Alloy C-20		61
AS	Alloy F44 Mo6		61
CA	Chrome-Moly Grade B-11/F-11 Class II		61
CB	Chrome-Moly Grade B-22/ F-22 Class III		61



**Table 4. Rosemount 114C Flanged Ordering Information**

The starred offerings (★) represent the most common options and should be selected for best delivery. The non-starred offerings are subject to additional delivery lead time.

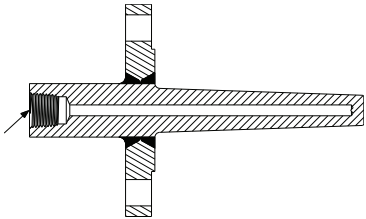
	CC	Chrome-Moly Grade F-91		61
	NK	Nickel 200		61
	TT	Titanium Grade 2		61
	DS	Super duplex SST Grade F-53		61
	DT	Super duplex – NORSOK	Must order the Q8 Material Certificate to get NORSOK documentation	62
	DU	Duplex 2205 Grade F51		61
	DV	Duplex 2205 – NORSOK	Must order the Q8 Material Certificate to get NORSOK documentation	62
<b>Place #s 16-18</b>	<b>Head length (H)</b>			<b>Ref. page</b>
★	xxx	xx.x-in., 2.25 to 11.25-in. in 1/4-in. increments (when ordered with dimension units code E) Example of a 6.25-in. length where the second decimal is dropped off: 062 (default head length = 2.25-in. for flanges under Class 900)		63
★	xxx	xxx mm, 45 to 225 mm in 5 mm increments (when ordered with dimension units code M) Example of a 50 mm length: 050 (default head length = 60 mm for flanges under Class 900)		63
<b>Place # 19</b>	<b>Instrument connection</b>	<b>Details</b>	<b>Image</b>	<b>Ref. page</b>
★	A	1/2–14 NPT		64
★	B	1/2–14 NPSM		64
	C	3/4–14 NPT		64
	D	M18 × 1.5p		64
	E	M20 × 1.5p		64
	F	M24 × 1.5p		64
	G	G 1/2-in. (BSPF)		64
	H	G 3/4-in. (BSPF)		64
	J	M27 × 2p		64
	K	M14 × 1.5p		64

**Options (include with selected model number)**

<b>Sensor/thermowell assemble to options</b>		<b>Details</b>	<b>Ref. page</b>	
★	XT	Hand tight assembly of sensor and thermowell	Ensures sensor is threaded into thermowell but only hand tightened	65
★	XW	Process-ready assembly of sensor and thermowell	Ensures sensor is threaded into thermowell and torqued for process-ready installation	65

**Table 4. Rosemount 114C Flanged Ordering Information**

The starred offerings (★) represent the most common options and should be selected for best delivery. The non-starred offerings are subject to additional delivery lead time.

<b>Extended product warranty</b>				<b>Ref. page</b>
★	WR3	3-year limited warranty	This warranty option extends manufacturer's warranty to three or five years for manufacturer related defects	65
★	WR5	5-year limited warranty		65
<b>Thermowell calculation</b>			<b>Details</b>	<b>Ref. page</b>
★	R21	Thermowell calculation	Set of calculations to ensure thermowells are safe in certain process conditions <i>Note: If your chosen mounting style is flange with full penetration weld (F) then you must choose dye penetration option (Q73) to meet the ASME PTC 19.3 TW standard requirements.</i>	65
<b>NACE certification</b>				<b>Ref. page</b>
★	Q35	NACE certification	Meets MR0175/ISO 15156 and MR0103 requirements	66
<b>PMI testing</b>				<b>Ref. page</b>
	Q76	PMI testing	Verifies chemical composition of material	66
<b>Material certification</b>				<b>Ref. page</b>
★	Q8	Material certification	Certificate for material conformance and traceability in accordance with EN 10204 type 3.1	67
<b>Material tests</b>				<b>Ref. page</b>
	M01	Low temperature Charpy Test	Measures the low temperature ductility of the material. This option drives a different weld documentation.	67
	M02	Ultrasonic material test	Examination of steel forgings for flaws and inclusions	67
<b>Surface finish</b>				<b>Ref. page</b>
	Q16	Certification	Certificate showing measured surface finish values	68
	R14	Finish < Ra 0.3 μm (12 μin)	Improves surface roughness of thermowell	68
<b>Electropolish</b>				<b>Ref. page</b>
	R20	Electropolish	Improve smoothness and surface quality	68
<b>Hydrostatic external pressure test</b>				<b>Ref. page</b>
★	Q5	Standard external pressure test	Verifies structural quality and checks for leaks at thermowell process connection and stem	68
★	Q9	Extended external pressure test	Same as standard external pressure test but tested for twice as long	69
<b>Hydrostatic internal pressure test</b>				<b>Ref. page</b>
★	Q85	Standard internal pressure test	Verifies internal structural integrity of thermowell	69
★	Q86	Extended internal pressure test	Same as standard internal pressure test but tested for twice as long	70

**Table 4. Rosemount 114C Flanged Ordering Information**

The starred offerings (★) represent the most common options and should be selected for best delivery. The non-starred offerings are subject to additional delivery lead time.

Canadian Registration Number			Ref. page
Q17	Canadian Registration Number	Canadian approvals for all provinces (Approved materials in reference section)	70
Dye penetration test			Ref. page
★ Q73	Dye penetration test	Checks quality of welds and material	70
Wall thickness test			Ref. page
Q83	Ultrasonic test	Checks the bore concentricity of the thermowell	71
Special cleaning			Ref. page
Q6	Special cleaning	Oxygen enriched environment cleaning per ASTM G93	71
Thermowell markings			Ref. page
R40	Test markings on thermowell	External marking of the thermowell for specific tests (see reference page for list of tests)	71
Phased array test			Ref. page
Q80	Phased array test	Verifies the quality of full penetration flange welds using ultrasonic technology	72
X-ray/radiograph test			Ref. page
Q81	X-ray/radiograph	Verifies quality of full penetration flange welds	72
Flange welding documentation			Ref. page
Q66	Procedure Qualification Records (PQR)	A record of a test weld performed and tested rigorously to ensure that the procedure will produce good weld.	72
Q67	Welder Performance Qualifications (WPQ)	A test certificate that shows whether a welder possesses the necessary experience and knowledge to perform the specifications of a particular weld procedure.	72
Q68	Welding Procedure Specifications (WPS)	A formal written document that describes and provides direction to a welder or welding operator for making sound and quality production welds per code requirement.	72
Spherical tip			Ref. page
R60	Spherical tip	Changes the flat tip to spherical	72
Plug and chain			Ref. page
R06	Stainless steel	Protects thermowell threads when sensor is not installed	73
R23	Brass		73

**Table 4. Rosemount 114C Flanged Ordering Information**

The starred offerings (★) represent the most common options and should be selected for best delivery. The non-starred offerings are subject to additional delivery lead time.

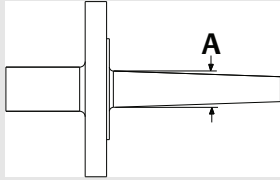
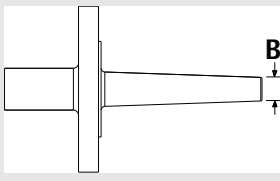
Vent hole			Ref. page
R11	Vent hole	Allows for the venting of a thermowell	73
Flange face			Ref. page
R09	Concentric serrations	Concentric serrations on flange face per ASME B16.5	74
R10	Flat	Flat flange face per ASME B16.5 or EN 1092-1 facing Type A	74
R15	Raised face, Type B2	Raise face per EN 1092-1 facing Type B2	75
R16	RTJ	Ring type joint flange face per ASME B16.5	76
R18	Groove, Type D	Groove, Type D per EN 1092-1	76
R19	Tongue, Type C	Tongue, Type C per EN 1092-1	77
R24	Spigot, Type E	Spigot Type E per EN 1092-1	78
R25	Recess, Type F	Recess Type F per EN 1092-1	78
Root diameter (A)			Ref. page
Axxx	x.xx-in., 0.36 to 3.15-in. in 0.01-in. increments (when ordered with dimension units code E) Examples: Code A040 = 0.4-in., Code A315 = 3.15-in.		80
Axxx	x.xx mm, 10 to 80 mm in 0.5 mm increments (when ordered with dimension units code M) Examples: Code A100 = 10.0 mm, Code A755 = 75.5 mm		80
Tip diameter (B)			Ref. page
Bxxx	x.xx-in., 0.36 to 1.83-in. in 0.01-in. increments (when ordered with dimension units code E) Examples: Code B040 = 0.4-in., Code B180 = 1.80-in.		81
Bxxx	xx.x mm, 10 to 46 mm in 0.5 mm increments (when ordered with dimension units code M) Examples: Code B100 = 10.0 mm, Code B455 = 45.5 mm		81

**Table 4. Rosemount 114C Flanged Ordering Information**

The starred offerings (★) represent the most common options and should be selected for best delivery. The non-starred offerings are subject to additional delivery lead time.

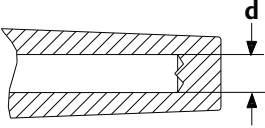
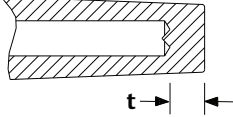
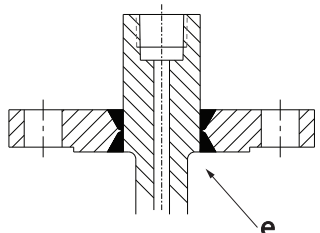
Non-standard bore diameter (d)		Details	Image	Ref. page
D01	0.276-in./7.0 mm	Standard = 0.26-in. (6.6 mm)		82
D03	0.138-in./3.5 mm			82
D04	0.386-in./9.8 mm			82
D05	0.354-in./9.0 mm			82
D06	0.433-in./11.0 mm			82
Non-standard tip thickness (t)		Details	Image	Ref. page
T01	0.197-in./5.0 mm	Standard = 0.25-in. (6.4 mm)		82
T02	0.236-in./6.0 mm			82
Fillet Radius (e)		Details	Image	Ref. page
E03	0.118-in./3 mm	Standard = 0.157-in. (4 mm)		83
E05	0.197-in./5 mm			

**Flanged installation**

Flanged thermowells are bolted to a mating flange which protrudes from the process. It is important to select appropriate gasket for the process conditions, to provide a seal between the flange faces. The Rosemount 114C Thermowells come standard with a raised face and spiral serrations designed per the ASME B16.5 standard. These should be installed with an inside bolt circle (IBC) gasket/ring gasket, which extends to and is centered by the bolts. Other flange face options are available.

**Figure 11. Installation Components**

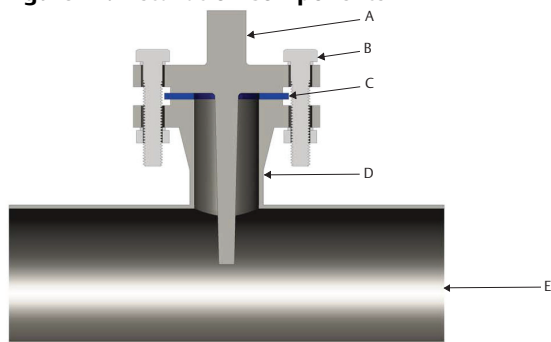

- A. Thermowell
- B. Bolt/washers
- C. Ring gasket
- D. Nozzle and mating flange
- E. Process

## Flanged thermowell drawings

Figure 12. Flange Mounted Thermowell Drawings<sup>(1)</sup>

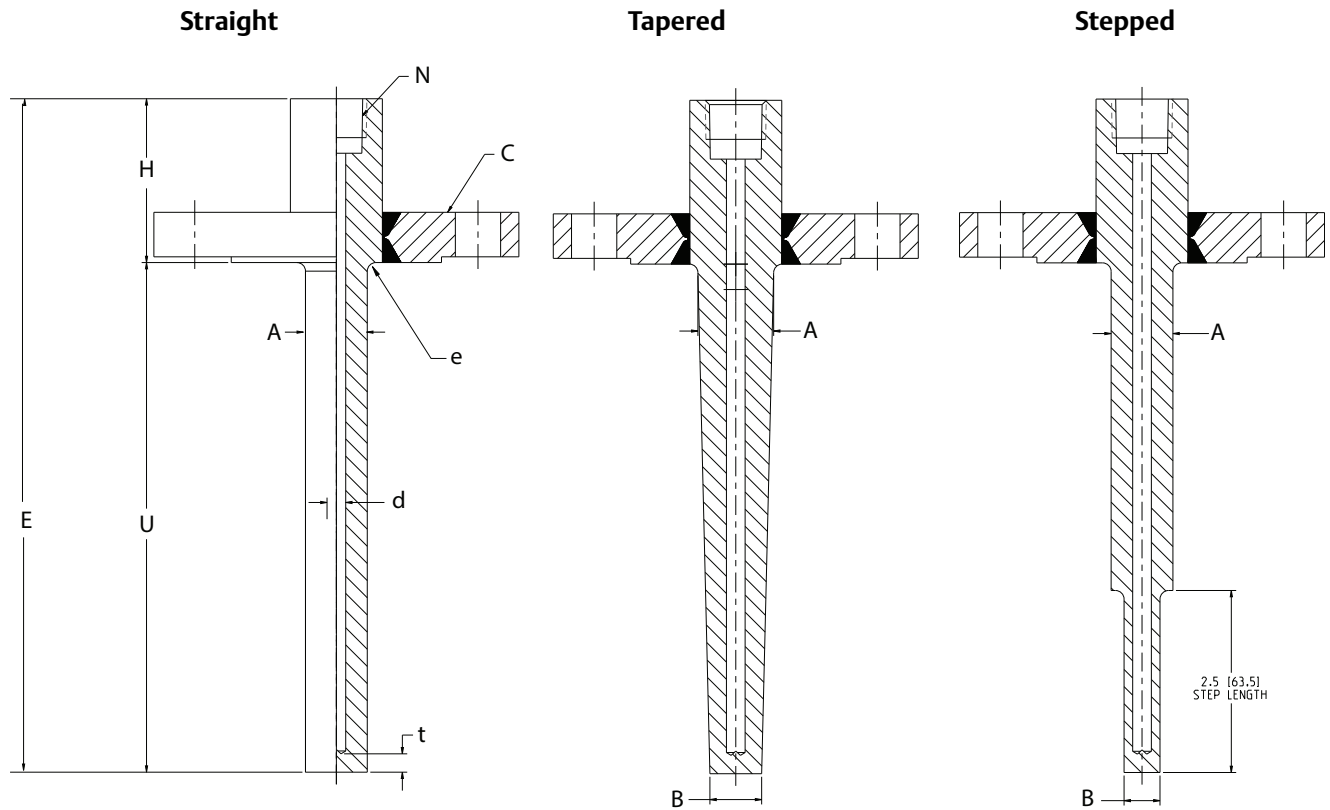

- A. Root diameter
- B. Tip diameter
- C. Lap flange
- E. Total length (U + H)
- H. Head length

- N. Instrument connection
- U. Immersion length
- d. Bore diameter
- e. Fillet radius
- t. Tip thickness

1. Total length = U+H.

**Table 5. Flange Mounted Thermowells<sup>(1)</sup>**

Code	Process connection			Root diameter stepped stem	Root diameter tapered stem	Tip diameter tapered stem	Tip diameter straight stem	Flanges per specification
	Code P, flanged, partial penetration weld	Code F, flanged, full penetration weld	Code G, flanged, forged/no welds					
AA	1-in. Class 150	1-in. Class 150	1-in. Class 150	19 (.748)	22.5 (.886)	16 (.630)	19 (.748)	ASME B16.5
AB	1 1/2-in. Class 150	1 1/2-in. Class 150	1 1/2-in. Class 150	21.5 (.846)	26.5 (1.043)	18 (.709)	21.5 (.846)	
AC	2-in. Class 150	2-in. Class 150	2-in. Class 150	21.5 (.846)	26.5 (1.043)	18 (.709)	21.5 (.846)	
AD	3-in. Class 150	3-in. Class 150	3-in. Class 150	21.5 (.846)	26.5 (1.043)	18 (.709)	21.5 (.846)	
AE	4-in. Class 150	4-in. Class 150	4-in. Class 150	21.5 (.846)	26.5 (1.043)	18 (.709)	21.5 (.846)	
AF	6-in. Class 150	6-in. Class 150	6-in. Class 150	21.5 (.846)	26.5 (1.043)	18 (.709)	21.5 (.846)	
AG	3/4-in. Class 300	3/4-in. Class 300	3/4-in. Class 300	17 (.669)	17 (.669)	12.5 (.495)	17 (.669)	
AH	1-in. Class 300	1-in. Class 300	1-in. Class 300	19 (.748)	22.5 (.886)	16 (.630)	19 (.748)	
AJ	1 1/2-in. Class 300	1 1/2-in. Class 300	1 1/2-in. Class 300	21.5 (.846)	26.5 (1.043)	18 (.709)	21.5 (.846)	
AK	2-in. Class 300	2-in. Class 300	2-in. Class 300	21.5 (.846)	26.5 (1.043)	18 (.709)	21.5 (.846)	
AL	1-in. Class 400/600	1-in. Class 400/600	1-in. Class 400/600	19 (.748)	22.5 (.886)	16 (.630)	19 (.748)	
AM	1 1/2-in. Class 400/600	1 1/2-in. Class 400/600	1 1/2-in. Class 400/600	21.5 (.846)	26.5 (1.043)	18 (.709)	21.5 (.846)	
AN	2-in. Class 400/600	2-in. Class 400/600	2-in. Class 400/600	21.5 (.846)	26.5 (1.043)	18 (.709)	21.5 (.846)	
AP	N/A	1-in. Class 900/1500	1-in. Class 900/1500	19 (.748)	22.5 (.886)	16 (.630)	19 (.748)	
AQ	N/A	1 1/2-in. Class 900/1500	1 1/2-in. Class 900/1500	21.5 (.846)	26.5 (1.043)	18 (.709)	21.5 (.846)	
AR	N/A	2-in. Class 900/1500	2-in. Class 900/1500	21.5 (.846)	26.5 (1.043)	18 (.709)	21.5 (.846)	
AT	N/A	1 1/2-in. Class 2500	1 1/2-in. Class 2500	21.5 (.846)	26.5 (1.043)	18 (.709)	21.5 (.846)	
AU	N/A	2-in. Class 2500	2-in. Class 2500	21.5 (.846)	26.5 (1.043)	18 (.709)	21.5 (.846)	
AV	3-in. Class 300	3-in. Class 300	3-in. Class 300	21.5 (.846)	26.5 (1.043)	18 (.709)	21.5 (.846)	
FA	DN 20/PN 2.5/6	DN 20/PN 2.5/6	DN 20/PN 2.5/6	17 (.669)	17 (.669)	12.7 (.500)	17 (.669)	
FE	DN 20/PN 10/16/25/40	DN 20/PN 10/16/25/40	DN 20/PN 10/16/25/40	17 (.669)	17 (.669)	12.7 (.500)	17 (.669)	
FG	DN 20/PN 63/100	DN 20/PN 63/100	DN 20/PN 63/100	17 (.669)	17 (.669)	12.7 (.500)	17 (.669)	
GA	DN 25/PN 2.5/6	DN 25/PN 2.5/6	DN 25/PN 2.5/6	19 (.748)	19 (.748)	12.7 (.500)	19 (.748)	
GE	DN 25/PN 10/16/25/40	DN 25/PN 10/16/25/40	DN 25/PN 10/16/25/40	19 (.748)	19 (.748)	12.7 (.500)	19 (.748)	
GG	DN 25/PN 63/100	DN 25/PN 63/100	DN 25/PN 63/100	19 (.748)	19 (.748)	12.7 (.500)	19 (.748)	
GH	DN 25/PN 160	DN 25/PN 160	DN 25/PN 160	19 (.748)	19 (.748)	12.7 (.500)	19 (.748)	
GJ	DN 25/PN 250	DN 25/PN 250	DN 25/PN 250	19 (.748)	19 (.748)	12.7 (.500)	19 (.748)	
GK	DN 25/PN 320	DN 25/PN 320	DN 25/PN 320	19 (.748)	19 (.748)	12.7 (.500)	19 (.748)	
GL	DN 25/PN 400	DN 25/PN 400	DN 25/PN 400	19 (.748)	19 (.748)	12.7 (.500)	19 (.748)	
JA	DN 40/PN 2.5/6	DN 40/PN 2.5/6	DN 40/PN 2.5/6	21.5 (.846)	26.5 (1.043)	18 (.709)	21.5 (.846)	
JE	DN 40/PN 10/16/25/40	DN 40/PN 10/16/25/40	DN 40/PN 10/16/25/40	21.5 (.846)	26.5 (1.043)	18 (.709)	21.5 (.846)	
JG	DN 40/PN 63/100	DN 40/PN 63/100	DN 40/PN 63/100	21.5 (.846)	26.5 (1.043)	18 (.709)	21.5 (.846)	
JH	DN 40/PN 160	DN 40/PN 160	DN 40/PN 160	21.5 (.846)	26.5 (1.043)	16 (.630)	21.5 (.846)	
JJ	DN 40/PN 250	DN 40/PN 250	DN 40/PN 250	21.5 (.846)	26.5 (1.043)	18 (.709)	21.5 (.846)	
JK	DN 40/PN 320	DN 40/PN 320	DN 40/PN 320	21.5 (.846)	26.5 (1.043)	18 (.709)	21.5 (.846)	
JL	DN 40/PN 400	DN 40/PN 400	DN 40/PN 400	21.5 (.846)	26.5 (1.043)	18 (.709)	21.5 (.846)	
KA	DN 50/PN 2.5/6	DN 50/PN 2.5/6	DN 50/PN 2.5/6	21.5 (.846)	26.5 (1.043)	18 (.709)	21.5 (.846)	
KC	DN 50/PN 10/16	DN 50/PN 10/16	DN 50/PN 10/16	21.5 (.846)	26.5 (1.043)	18 (.709)	21.5 (.846)	
KE	DN 50/PN 25/40	DN 50/PN 25/40	DN 50/PN 25/40	21.5 (.846)	26.5 (1.043)	18 (.709)	21.5 (.846)	
KF	DN 50/PN 63	DN 50/PN 63	DN 50/PN 63	21.5 (.846)	26.5 (1.043)	18 (.709)	21.5 (.846)	
KG	DN 50/PN 100	DN 50/PN 100	DN 50/PN 100	21.5 (.846)	26.5 (1.043)	18 (.709)	21.5 (.846)	
KH	DN 50/PN 160	DN 50/PN 160	DN 50/PN 160	21.5 (.846)	26.5 (1.043)	18 (.709)	21.5 (.846)	

**Table 5. Flange Mounted Thermowells<sup>(1)</sup>**

Code	Process connection			Root diameter stepped stem	Root diameter tapered stem	Tip diameter tapered stem	Tip diameter straight stem	Flanges per specification
	Code P, flanged, partial penetration weld	Code F, flanged, full penetration weld	Code G, flanged, forged/no welds					
KJ	DN 50/PN 250	DN 50/PN 250	DN 50/PN 250	21.5 (.846)	26.5 (1.043)	18 (.709)	21.5 (.846)	EN 1092-1
KK	DN 50/PN 320	DN 50/PN 320	DN 50/PN 320	21.5 (.846)	26.5 (1.043)	18 (.709)	21.5 (.846)	
KL	DN 50/PN 400	DN 50/PN 400	DN 50/PN 400	21.5 (.846)	26.5 (1.043)	18 (.709)	21.5 (.846)	
LA	DN 65/PN 2.5/6	DN 65/PN 2.5/6	DN 65/PN 2.5/6	21.5 (.846)	26.5 (1.043)	18 (.709)	21.5 (.846)	
LC	DN 65/PN 10/16	DN 65/PN 10/16	DN 65/PN 10/16	21.5 (.846)	26.5 (1.043)	18 (.709)	21.5 (.846)	
LE	DN 65/PN 24/40	DN 65/PN 24/40	DN 65/PN 24/40	21.5 (.846)	26.5 (1.043)	18 (.709)	21.5 (.846)	
LF	DN 65/PN 63	DN 65/PN 63	DN 65/PN 63	21.5 (.846)	26.5 (1.043)	18 (.709)	21.5 (.846)	
LG	DN 65/PN 100	DN 65/PN 100	DN 65/PN 100	21.5 (.846)	26.5 (1.043)	18 (.709)	21.5 (.846)	
LH	DN 65/PN 160	DN 65/PN 160	DN 65/PN 160	21.5 (.846)	26.5 (1.043)	18 (.709)	21.5 (.846)	
LJ	DN 65/PN 250	DN 65/PN 250	DN 65/PN 250	21.5 (.846)	26.5 (1.043)	18 (.709)	21.5 (.846)	
LK	DN 65/PN 320	DN 65/PN 320	DN 65/PN 320	21.5 (.846)	26.5 (1.043)	18 (.709)	21.5 (.846)	
LL	DN 65/PN 400	DN 65/PN 400	DN 65/PN 400	21.5 (.846)	26.5 (1.043)	18 (.709)	21.5 (.846)	
MA	DN 80/PN 2.5/6	DN 80/PN 2.5/6	DN 80/PN 2.5/6	21.5 (.846)	26.5 (1.043)	18 (.709)	21.5 (.846)	
MC	DN 80/PN 10/16	DN 80/PN 10/16	DN 80/PN 10/16	21.5 (.846)	26.5 (1.043)	18 (.709)	21.5 (.846)	
ME	DN 80/PN 25/40	DN 80/PN 25/40	DN 80/PN 25/40	21.5 (.846)	26.5 (1.043)	18 (.709)	21.5 (.846)	
MF	DN 80/PN 63	DN 80/PN 63	DN 80/PN 63	21.5 (.846)	26.5 (1.043)	18 (.709)	21.5 (.846)	
MG	DN 80/PN 100	DN 80/PN 100	DN 80/PN 100	21.5 (.846)	26.5 (1.043)	18 (.709)	21.5 (.846)	
MH	DN 80/PN 160	DN 80/PN 160	DN 80/PN 160	21.5 (.846)	26.5 (1.043)	18 (.709)	21.5 (.846)	
MJ	DN 80/PN 250	DN 80/PN 250	DN 80/PN 250	21.5 (.846)	26.5 (1.043)	18 (.709)	21.5 (.846)	
MK	DN 80/PN 320	DN 80/PN 320	DN 80/PN 320	21.5 (.846)	26.5 (1.043)	18 (.709)	21.5 (.846)	
ML	DN 80/PN 400	DN 80/PN 400	DN 80/PN 400	21.5 (.846)	26.5 (1.043)	18 (.709)	21.5 (.846)	
NA	DN 100/PN 2.5/6	DN 100/PN 2.5/6	DN 100/PN 2.5/6	21.5 (.846)	26.5 (1.043)	18 (.709)	21.5 (.846)	
NC	DN 100/PN 10/16	DN 100/PN 10/16	DN 100/PN 10/16	21.5 (.846)	26.5 (1.043)	18 (.709)	21.5 (.846)	
NE	DN 100/PN 25/40	DN 100/PN 25/40	DN 100/PN 25/40	21.5 (.846)	26.5 (1.043)	18 (.709)	21.5 (.846)	
NF	DN 100/PN 63	DN 100/PN 63	DN 100/PN 63	21.5 (.846)	26.5 (1.043)	18 (.709)	21.5 (.846)	
NG	DN 100/PN 100	DN 100/PN 100	DN 100/PN 100	21.5 (.846)	26.5 (1.043)	18 (.709)	21.5 (.846)	

1. Dimensions are in millimeters (inches).

**Table 6. External Pressure Test–EN 1092-1**

EN 1092-1 flanged thermowells	
Nominal pressure (bar)	Test pressure (bar)
16	40
40	100
100	250
Test to 2.5× nominal pressure rating	



## Rosemount 114C Van Stone Thermowells



## Van Stone thermowell overview

Van Stone/lap joint thermowells are mounted between the mating flange and lap joint flange. This unique design enables thermowell designers to specify thermowell flange materials different than the thermowell stem material; flanges are easily replaceable. These thermowells allow use of different thermowell materials for the flange contacting the process and overlaying flange which can save material and manufacturing costs. They are a good choice for corrosive applications, because there are no welds so weld-joint corrosion is eliminated. The Emerson standard for the Van Stone thermowell is a raised face style made of carbon steel. Other styles and flange materials are also available.

The standard offering figure below shows the thermowell configurations that can typically be shipped in two weeks or less.

**Figure 13. Standard Offering–Van Stone**

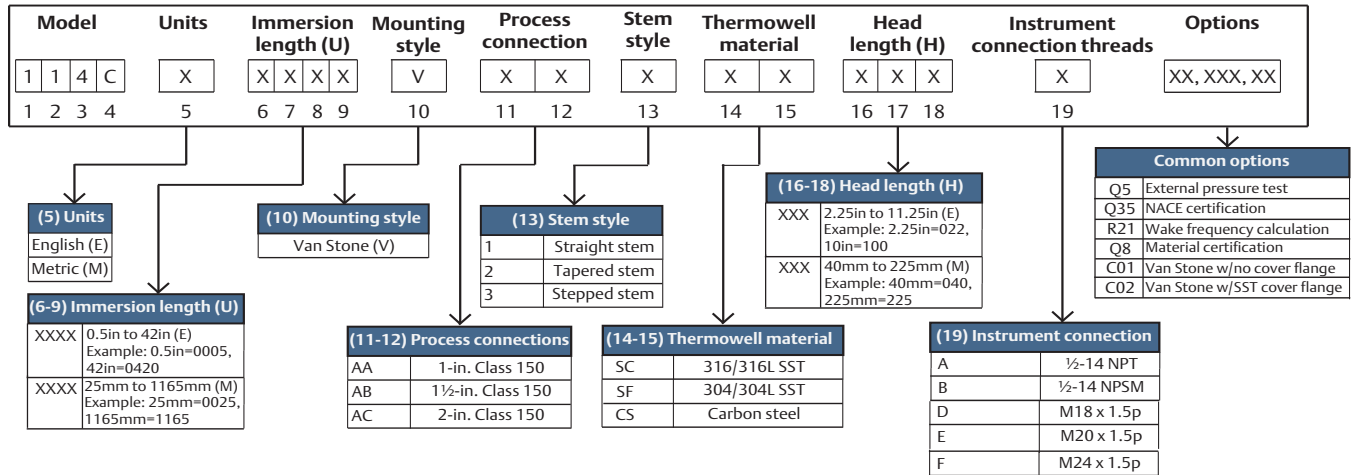

The common options shown in Figure 13 represent a partial offering; reference the [Rosemount 114C Van Stone Ordering Information](#) for a full list of available options.

**Figure 14. Van Stone Thermowell Components**

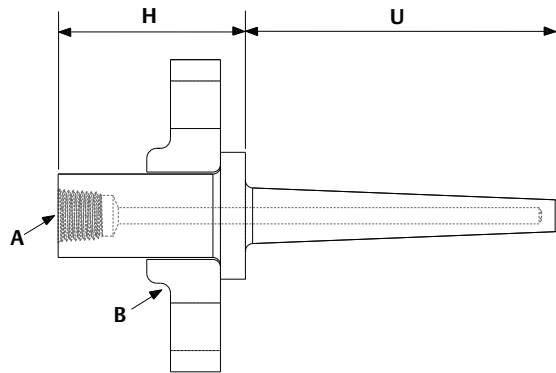

A. Instrument connection  
B. Process connection

H. Head length  
U. Immersion length

**Note**

Wetted surface includes flange face and immersion length (U).

Use the form below to record your model code:

Model				Units	Immersion length (U)	Mounting style	Process connection	Stem style	Thermowell material	Head length (H)	Instrument connection	Options
1	1	4	C			V						
1	2	3	4	5	6 through 9	10	11 and 12	13	14 and 15	16 through 18	19	XXXXX

## Van Stone ordering information

Figure 15. Model Number Ordering Example

Model				Units	Immersion length (U)				Mounting style	Process connection		Stem style	Thermowell material		Head length (H)	Instrument connection	Options		
1	1	4	C	M	0	1	5	0	V	A	B	1	S	C	0	5	0	A	WR5, Q76...
1	2	3	4	5	6	7	8	9	10	11	12	13	14	15	16	17	18	19	XXXXX

The numbers below the model number ordering example correlate to the character place numbers in the second column of the ordering table.

Table 7. Rosemount 114C Van Stone Ordering Information

★The Standard offering represents the most common options. The starred options (★) should be selected for best delivery lead time. The Expanded offering is subject to additional delivery lead time.

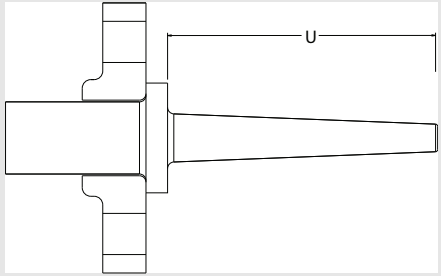
Place #s 1-4	Model	Details	Ref. page
★ 114C	Barstock temperature thermowell	Made with a standard bore diameter of 0.26-in. (6.6 mm) and tip wall thickness of 0.25-in. (6.4 mm). Default cover flange material is carbon steel.	N/A
Place # 5	Dimension units	Details	Ref. page
★ E	English units (inches)	Specifies whether length units will be in inches (in.) or millimeters (mm)	59
★ M	Metric units (mm)		59
Place # 6-9	Immersion length (U)		Ref. page
★ xxxx	xx.x-in., 1.0 to 100-in. in 1/4-in. increments (when ordered with dimension units code E) Example of a 6.25-in. length where the second decimal is dropped off: 0062		59
★ xxxx	xxxx mm, 25 to 2500 mm in 5 mm increments (when ordered with dimension units code M) Example of a 25 mm length: 0025		59
Place # 10	Mounting style	Details	Ref. page
★ V	Van Stone, lap flange	Default cover flange material is carbon steel	N/A
Place #s 11-12	Process connection	Details	Ref. page
★ AA	1-in. Class 150		N/A
★ AB	1 1/2-in. Class 150		N/A
★ AC	2-in. Class 150		N/A

**Table 7. Rosemount 114C Van Stone Ordering Information**

★The Standard offering represents the most common options. The starred options (★) should be selected for best delivery lead time. The Expanded offering is subject to additional delivery lead time.

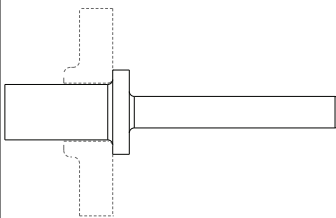
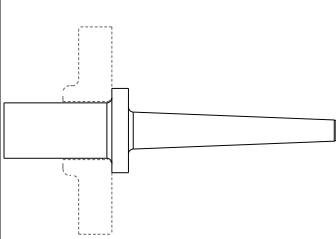
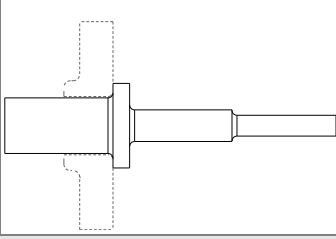
★	AH	1-in. Class 300			N/A
★	AJ	1½-in. Class 300			N/A
★	AK	2-in. Class 300			N/A
★	AL	1-in. Class 400/600			N/A
★	AM	1½-in. Class 400/600			N/A
★	AN	2-in. Class 400/600			N/A
	AP	1-in. Class 900/1500			N/A
	AQ	1½-in. Class 900/1500			N/A
	AR	2-in. Class 900/1500			N/A
	AS	1-in. Class 2500			N/A
	AT	1½-in. Class 2500			N/A
	AU	2-in. Class 2500			N/A
Place # 13	Stem style	Details	Image	Ref. page	
★	1	Straight	Minimum immersion length = 1-in. (25 mm)		60
★	2	Tapered	Minimum immersion length = 1-in. (25 mm)		60
★	3	Stepped	Minimum immersion length = 3-in. (75 mm)		60
Place #s 14-15	Thermowell material	Details		Ref. page	
★	SC	316/316L dual rated		61	
	SD	316/316L dual rated (NORSOK)	Must order the Q8 Material Certificate to get NORSOK documentation	62	
★	SF	304/304L dual rated		61	

**Table 7. Rosemount 114C Van Stone Ordering Information**

★The Standard offering represents the most common options. The starred options (★) should be selected for best delivery lead time. The Expanded offering is subject to additional delivery lead time.

★	CS	Carbon steel (A-105)		61
	SG	316Ti SST		61
	SH	316/316L SST with tantalum sheath		61
	SJ	316/316L SST with PFA coating		61
	SK	304/304L SST with PTFE coating		61
	SL	310 SST		61
	SM	321 SST		61
	SN	321H SST		61
	SR	904L SST		61
	SP	347 SST		61
	AB	Alloy B3		61
	AC	Alloy C-276		61
	AG	Alloy 20		61
	AH	Alloy 400		61
	AK	Alloy 600		61
	AM	Alloy 601		61
	AN	Alloy 625		61
	AP	Alloy 800		61
	AQ	Alloy 800H/HT		61
	AR	Alloy 825		61
	AU	Alloy C-20		61
	MO	Molybdenum		61
	CA	Chrome-Moly Grade B-11/F-11 Class II		61
	CB	Chrome-Moly Grade B-22/ F-22 Class III		61
	CC	Chrome-Moly Grade F-91		61
	NK	Nickel 200		61
	TT	Titanium Grade 2		61
	DS	Super duplex SST Grade F-53		61
	DT	Super duplex – NORSOK	Must order the Q8 Material Certificate to get NORSOK documentation	62
	DU	Duplex 2205 Grade F51		61
	DV	Duplex 2205 – NORSOK	Must order the Q8 Material Certificate to get NORSOK documentation	62

**Table 7. Rosemount 114C Van Stone Ordering Information**

★The Standard offering represents the most common options. The starred options (★) should be selected for best delivery lead time. The Expanded offering is subject to additional delivery lead time.

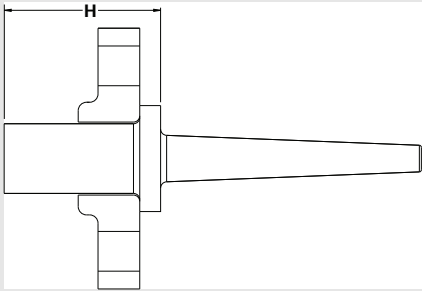
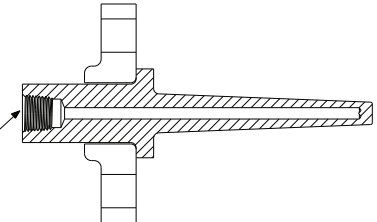
Place #s 16-18	Head length (H)			Ref. page
★ xxx	xx.x-in., 1.75to 11.25-in. in 1/4-in. increments (when ordered with Dimension units code E) Example of a 6.25-in. length where the second decimal is dropped off: 062 (default head length = 2.25-in. for flanges under Class 900)			63
★ xxx	xxx mm, 40 to 225 mm in 5 mm increments (when ordered with Dimension units code M) Example of a 50 mm length: 050 (default head length = 60 mm for flanges under Class 900)			63
Place # 19	Instrument connection	Details	Image	Ref. page
★ A	1/2-14 NPT	Female threads		64
★ B	1/2-14 NPSM			64
C	3/4-14 NPT			64
D	M18 × 1.5p			64
E	M20 × 1.5p			64
F	M24 × 1.5p			64
G	G 1/2-in. (BSPF)			64
H	G 3/4-in. (BSPF)			64
J	M27 × 2p			64
K	M14 × 1.5p			64

**Options (include with selected model number)**

Sensor/thermowell assemble to options	Details	Ref. page
★ XT	Hand tight assembly of sensor and thermowell	Ensures sensor is threaded into thermowell but only hand tightened
★ XW	Process-ready assembly of sensor and thermowell	Ensures sensor is threaded into thermowell and torqued for process-ready installation
Extended product warranty	Details	Ref. page
★ WR3	3-year limited warranty	This warranty option extends manufacturer’s warranty to three or five years for manufacturer related defects
★ WR5	5-year limited warranty	65

**Table 7. Rosemount 114C Van Stone Ordering Information**

★The Standard offering represents the most common options. The starred options (★) should be selected for best delivery lead time. The Expanded offering is subject to additional delivery lead time.

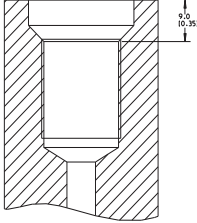
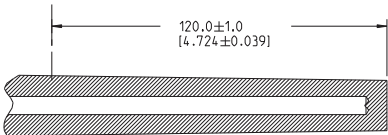
Thermowell calculation		Details	Ref. page	
★	R21	Thermowell calculation	Set of calculations to ensure thermowells are safe in certain process conditions	65
NACE certification		Details	Ref. page	
★	Q35	NACE certification	Meets MR0175/ISO 15156 and MR0103 requirements	66
PMI testing		Details	Ref. page	
	Q76	PMI testing	Verifies chemical composition of material	66
Material certification		Details	Ref. page	
★	Q8	Material certification	Certificate for material conformance and traceability in accordance with EN 10204 type 3.1	67
Material tests		Details	Ref. page	
	M01	Low temperature Charpy Test	Measures the low temperature ductility of the material	67
	M02	Ultrasonic material test	Examination of steel forgings for flaws and inclusions	67
Surface finish		Details	Ref. page	
	Q16	Certification	Certificate showing measured surface finish values	68
	R14	Finish < Ra 0.3 μm (12 μin)	Improves surface roughness of thermowell	68
Electropolish		Details	Ref. page	
	R20	Electropolish	Improve smoothness and surface quality	68
Stepped instrument threads		Image	Ref. page	
	R61	Stepped instrument threads		68
Roughened stem		Details	Image	Ref. page
	R62	Roughened stem	Roughens the last 4.7-in. (120 mm) of the stem 	N/A



**Table 7. Rosemount 114C Van Stone Ordering Information**

★The Standard offering represents the most common options. The starred options (★) should be selected for best delivery lead time. The Expanded offering is subject to additional delivery lead time.

<b>Hydrostatic external pressure test</b>			<b>Details</b>	<b>Ref. page</b>
★	Q5	Standard external pressure test	Verifies structural quality and checks for leaks at thermowell process connection and stem	68
★	Q9	Extended external pressure test	Same as standard external pressure test but tested for twice as long	69
<b>Hydrostatic internal pressure test</b>			<b>Details</b>	<b>Ref. page</b>
★	Q85	Standard internal pressure test	Verifies internal structural integrity of thermowell	69
★	Q86	Extended internal pressure test	Same as standard internal pressure test but tested for twice as long	70
<b>Canadian Registration Number</b>			<b>Details</b>	<b>Ref. page</b>
	Q17	Canadian Registration Number	Canadian approvals for all provinces (Approved materials in reference section)	70
<b>Dye penetration test</b>			<b>Details</b>	<b>Ref. page</b>
★	Q73	Dye penetration test	Checks quality of welds and material	70
<b>Wall thickness test</b>			<b>Details</b>	<b>Ref. page</b>
	Q83	Ultrasonic test	Checks the bore concentricity of the thermowell	71
<b>Special cleaning</b>			<b>Details</b>	<b>Ref. page</b>
	Q6	Special cleaning	Oxygen enriched environment cleaning per ASTM G93	71
<b>Thermowell markings</b>			<b>Details</b>	<b>Ref. page</b>
	R40	Test markings on thermowell	External marking of the thermowell for specific tests (see reference page for list of tests)	71
<b>Spherical tip</b>			<b>Details</b>	<b>Ref. page</b>
	R60	Spherical tip	Changes the flat tip to spherical	72
<b>Plug and chain</b>			<b>Details</b>	<b>Ref. page</b>
	R06	Stainless steel	Protects thermowell threads when sensor is not installed	73
	R23	Brass		73
<b>Vent hole</b>			<b>Details</b>	<b>Ref. page</b>
	R11	Vent hole	Allows for the venting of a thermowell	73
<b>Flange face</b>			<b>Details</b>	<b>Ref. page</b>
	R09	Concentric serrations	Concentric serrations on flange face per ASME B16.5	74
	R16	RTJ	Ring type joint flange face per ASME B16.5	75

**Table 7. Rosemount 114C Van Stone Ordering Information**

★The Standard offering represents the most common options. The starred options (★) should be selected for best delivery lead time. The Expanded offering is subject to additional delivery lead time.

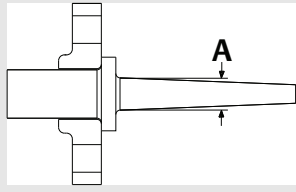
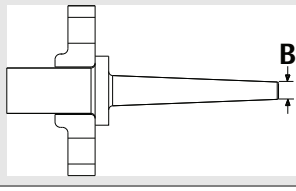
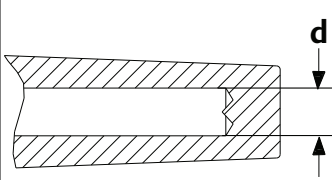
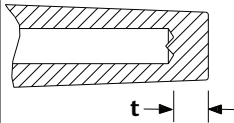
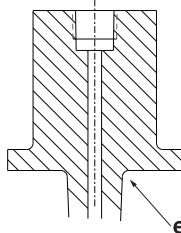
<b>Root diameter (A)</b>			<b>Ref. page</b>
Axxx	x.xx-in., 0.36 to 3.15-in. in 0.01-in. increments (when ordered with dimension units code E) Examples: Code A040 = 0.4-in, Code A315 = 3.15-in.		80
Axxx	xx.x mm, 10 to 80 mm in 0.5 mm increments (when ordered with dimension units code M) Examples: Code A100 = 10.0 mm, Code A755 = 75.5 mm		80
<b>Tip diameter (B)</b>			<b>Ref. page</b>
Bxxx	x.xx-in., 0.36 to 1.83-in. in 0.01-in. increments (when ordered with dimension units code E) Examples: Code B040 = 0.4-in, Code B180 = 1.80-in.		81
Bxxx	xx.x mm, 10 to 46 mm in 0.5 mm. increments (when ordered with dimension units code M) Examples: Code B100 = 10.0 mm, Code B455 = 45.5 mm		81
<b>Non-standard bore diameter (d)</b>		<b>Details</b>	<b>Image</b>
D01	0.276-in./7.0 mm	Standard = 0.26-in. (6.6 mm)	
D03	0.138-in./3.5 mm		
D04	0.386-in./9.8 mm		
D05	0.354-in./9.0 mm		
D06	0.433-in./11.0 mm		
<b>Non-standard tip thickness (t)</b>		<b>Details</b>	<b>Image</b>
T01	0.197-in./5.0 mm	Standard = 0.25-in. (6.4 mm)	
T02	0.236-in./6.0 mm		
<b>Fillet Radius (e)</b>		<b>Details</b>	<b>Image</b>
E03	0.118-in./3 mm	Standard = 0.157-in. (4 mm)	
E05	0.197-in./5 mm		

**Table 7. Rosemount 114C Van Stone Ordering Information**

★The Standard offering represents the most common options. The starred options (★) should be selected for best delivery lead time. The Expanded offering is subject to additional delivery lead time.

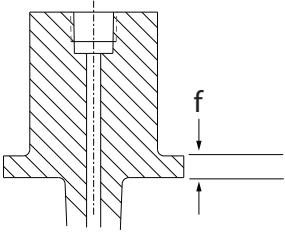
Van stone stub thickness		Details	Image	Ref. page
F01	0.591-in. (15 mm)	Standard = 0.394-in. (10 mm)		83
F02	0.787-in. (20 mm)			
Lap flange material for Van Stone design		Details		Ref. page
C01	No flange	Provides a Van Stone stem without a lap flange.		84
C02	316/316LSST flange	Provides a Van Stone stem with a 316/316LSST lap flange.		84
C03	Flange per stem material	Provides a Van Stone stem with a matching lap flange per stem material. Coatings do not apply to lap flange.		84

**Van Stone installation**

Van Stone thermowells are installed using a lap joint flange which slips over the stub end of the thermowell. The lap joint flange has no flange face. Instead the flange is bolted over the stub end which acts as the flange face and compresses the gasket. The Rosemount 114C Thermowells come standard with spiral serrations on the stub end designed per the ASME B16.5 standard. These should be installed with an inside bolt circle (IBC) gasket/ring gasket, which extends to and is centered by the bolts. Other flange face options are available.

**Figure 16. Installation Components**

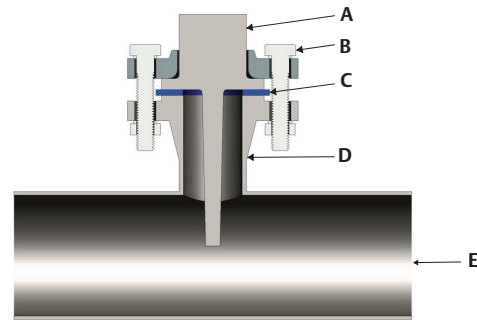

- A. Thermowell
- B. Bolt/washers
- C. Ring gasket
- D. Nozzle and mating flange
- E. Process

## Van Stone thermowell drawings

Figure 17. Van Stone/Lap Flanged Mounted Thermowell Drawings<sup>(1)</sup>

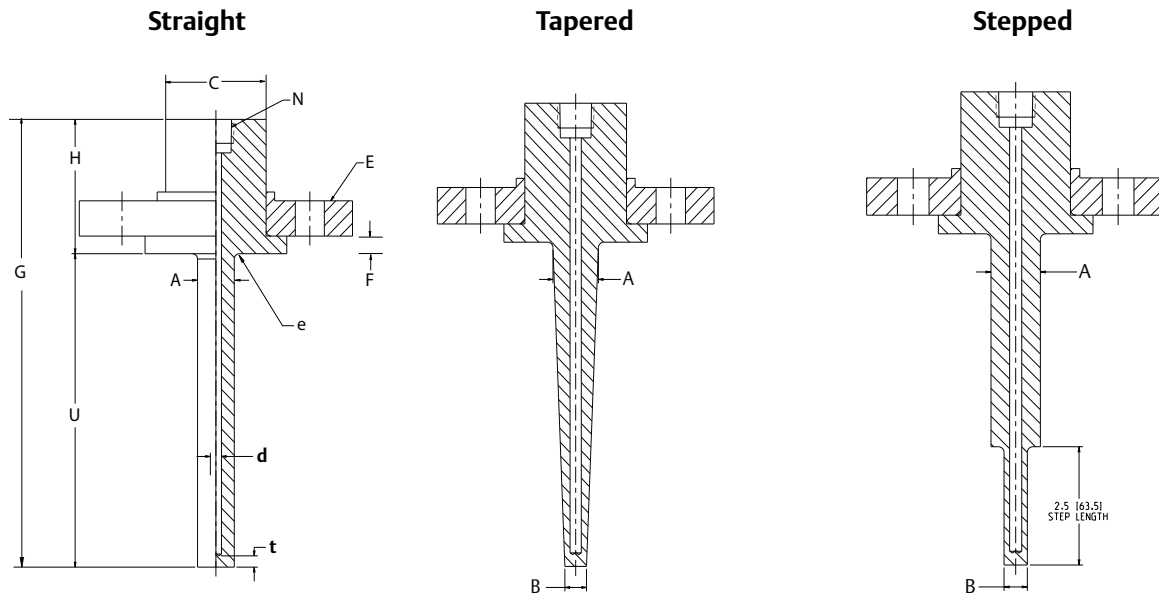

A. Root diameter  
 B. Tip diameter  
 C. Head diameter  
 E. ASME B16.5 lap flange

F. Stub thickness  
 H. Head length  
 N. Instrument connection (1/2-in. NPT)  
 U. Immersion length

d. Bore diameter  
 e. Fillet radius  
 t. Tip thickness

1. Total length = U + H.

Table 8. Van Stone/Lap Flanged Mounted Thermowells<sup>(1)</sup>

Code	Code V, Van Stone lap flange mounting style	Lagging diameter "C"	Stub diameter K standard raised face	Stub diameter K ring type joint option R16	Stub thickness "F" standard raised face	Stub thickness "F" ring type joint option R16	Root diameter stepped stem	Root diameter tapered stem	Tip diameter tapered stem	Tip diameter straight stem
	Process connection									
AA	1-in. Class 150	1.31 (33.4)	1.99 (50.8)	2.50 (63.5)	10 (.394)	0.644 (16.35)	0.75 (19)	0.89 (22.5)	0.63 (16)	.75 (19)
AB	1 1/2-in. Class 150	1.90 (48.3)	2.87 (73)	3.25 (82.5)		0.644 (16.35)	0.85 (21.5)	1.04 (26.5)	0.71 (18)	.85 (21.5)
AC	2-in. Class 150	2.37 (60.3)	3.62 (92.1)	4 (102)		0.644 (16.35)	0.85 (21.5)	1.04 (26.5)	0.71 (18)	.85 (21.5)
AH	1-in. Class 300	1.31 (33.4)	1.99 (50.8)	2.75 (70)		0.644 (16.35)	0.75 (19)	0.89 (22.5)	0.63 (16)	.75 (19)
AJ	1 1/2-in. Class 300	1.90 (48.3)	2.87 (73)	3.56 (90.5)		0.644 (16.35)	0.85 (21.5)	1.04 (26.5)	0.71 (18)	.85 (21.5)
AK	2-in. Class 300	2.37 (60.3)	3.62 (92.1)	4.25 (108)		0.707 (17.92)	0.85 (21.5)	1.04 (26.5)	0.71 (18)	.85 (21.5)
AL	1-in. Class 400/600	1.31 (33.4)	1.99 (50.8)	2.75 (70)		0.644 (16.35)	0.75 (19)	0.89 (22.5)	0.63 (16)	.75 (19)
AM	1 1/2-in. Class 400/600	1.90 (48.3)	2.87 (73)	3.56 (90.5)		0.644 (16.35)	0.85 (21.5)	1.04 (26.5)	0.71 (18)	.85 (21.5)
AN	2-in. Class 400/600	2.37 (60.3)	3.62 (92.1)	4.25 (108)		0.707 (17.92)	0.85 (21.5)	1.04 (26.5)	0.71 (18)	.85 (21.5)
AP	1-in. Class 900/1500	1.31 (33.4)	1.99 (50.8)	2.81 (71.5)		0.644 (16.35)	0.75 (19)	0.89 (22.5)	0.63 (16)	.75 (19)
AQ	1 1/2-in. Class 900/1500	1.90 (48.3)	2.87 (73)	3.62 (92)		0.644 (16.35)	0.85 (21.5)	1.04 (26.5)	0.71 (18)	.85 (21.5)
AR	2-in. Class 900/1500	2.37 (60.3)	3.62 (92.1)	4.88 (124)		0.707 (17.92)	0.85 (21.5)	1.04 (26.5)	0.71 (18)	.85 (21.5)
AS	1-in. Class 2500	1.31 (33.4)	1.99 (50.8)	3.25 (82.5)		0.644 (16.35)	0.75 (19)	0.89 (22.5)	0.63 (16)	.75 (19)
AT	1 1/2-in. Class 2500	1.90 (48.3)	2.87 (73)	4.50 (114)		0.707 (17.92)	0.85 (21.5)	1.04 (26.5)	0.71 (18)	.85 (21.5)
AU	2-in. Class 2500	2.37 (60.3)	3.62 (92.1)	5.25 (133)		0.707 (17.92)	0.85 (21.5)	1.04 (26.5)	0.71 (18)	.85 (21.5)

1. Dimensions are in inches (millimeters).

## Rosemount 114C Welded Thermowells



## Welded thermowell overview

Welded thermowells are permanently welded to process pipes or tanks. Welded thermowells have the highest pressure rating and are generally used in applications with high velocity flow, high temperature, or extremely high pressure. They are necessary where a leak-proof seal is required.

The standard offering figure below shows the thermowell configurations that can typically be shipped in two weeks or less.

**Figure 18. Standard Offering–Welded**

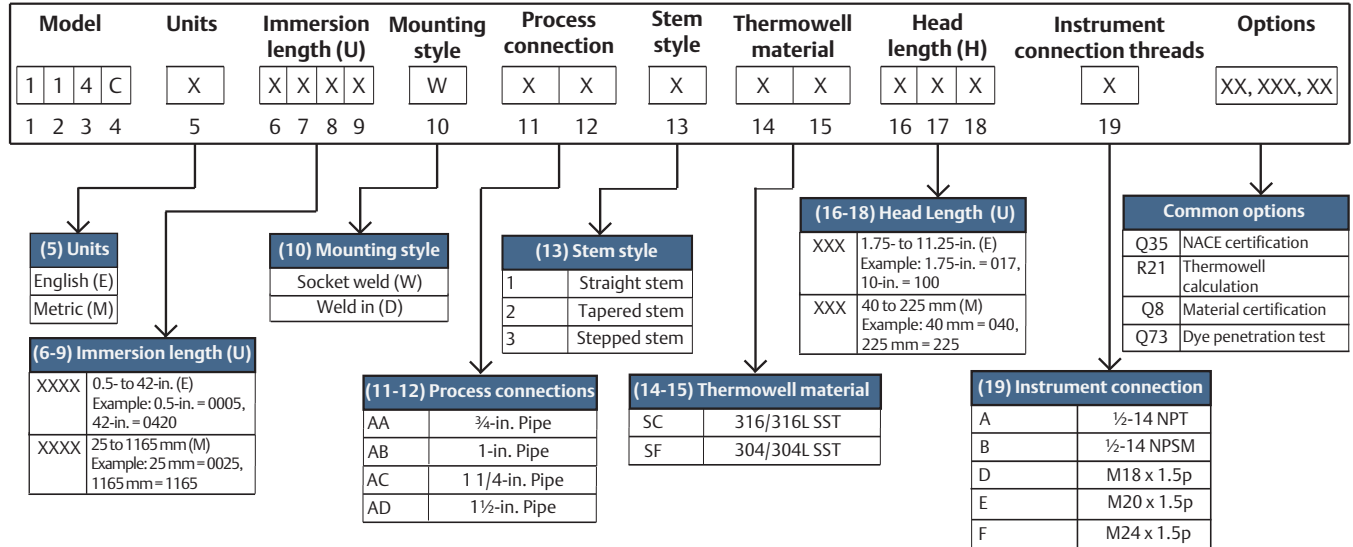

The common options shown in Figure 18 represent a partial offering; reference the [Rosemount 114C Welded Ordering Information](#) for a full list of available options.

**Figure 19. Welded Thermowell Components**

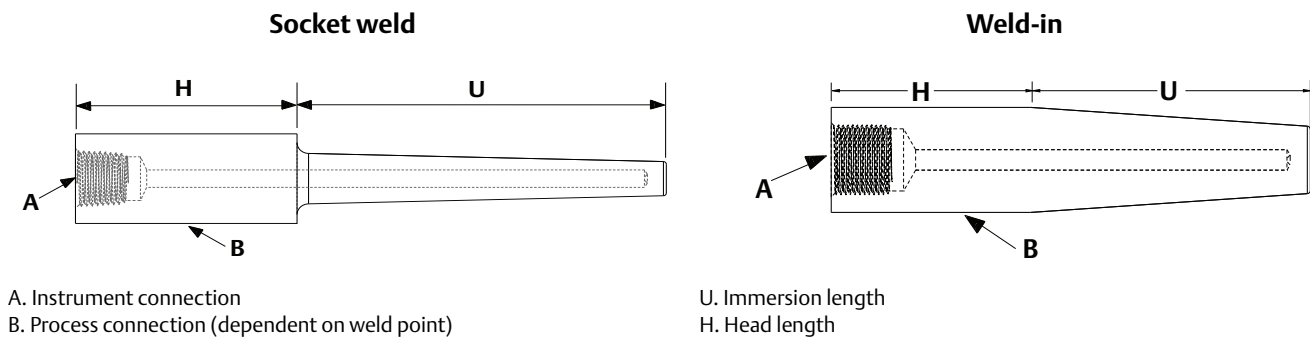

**Note**

Actual wetted surface varies; it is measured from the weld point to the thermowell tip.

Use the form below to record your model code:

Model				Units	Immersion length (U)	Mounting style	Process connection	Stem style	Thermowell material	Head length (H)	Instrument connection	Options
1	1	4	C									
1	2	3	4	5	6 through 9	10	11 and 12	13	14 and 15	16 through 18	19	XXXXX



## Welded ordering information

Figure 20. Model Number Ordering Example

Model				Units	Immersion length (U)				Mounting style	Process connection		Stem style	Thermowell material		Head length (H)			Instrument connection	Options
1	1	4	C	E	0	0	6	0	W	A	B	1	S	C	0	5	0	A	WR5, Q76...
1	2	3	4	5	6	7	8	9	10	11	12	13	14	15	16	17	18	19	XXXXX

The numbers below the model number ordering example correlate to the character place numbers in the second column of the ordering table.

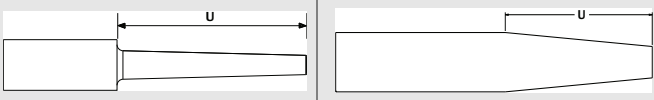
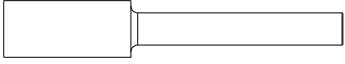

Table 9. Rosemount 114C Welded Ordering Information

★ The Standard offering represents the most common options. The starred options (★) should be selected for best delivery lead time. The Expanded offering is subject to additional delivery lead time.

Place #s 1-4	Model	Details	Ref. page
★ 114C	Barstock temperature thermowell	Made with a standard bore diameter of 0.26-in. (6.6 mm) and tip wall thickness of 0.25-in. (6.4 mm)	N/A
Place # 5	Dimension units	Details	Ref. page
★ E	English units (inches)	Specifies whether length units will be in inches (in.) or millimeters (mm)	59
★ M	Metric units (mm)		59
Place # 6-9	Immersion length (U)		Ref. page
★ xxxx	xxx-in., 1 to 100-in. in 1/4-in. increments (when ordered with dimension units code E) Example of a 6.25-in. length where the second decimal is dropped off: 0062		59
★ xxxx	xxxx mm, 25 to 2500 mm in 5 mm increments (when ordered with dimension units code M) Example of a 50 mm length: 0050		59
Place # 10	Mounting style	Details	Ref. page
★ W	Welded–socket weld		N/A
★ D	Welded–weld-in (only available in tapered stem profile)		N/A
Place #s 11-12	Process connections	Details	Ref. page
	<b>Welded–socket weld (W)</b>	<b>Welded–weld-in (D) (only available in tapered stem profile)</b>	
★ AA	3/4-in. pipe	3/4-in. pipe	N/A
★ AB	1-in. pipe	1-in. pipe	N/A
★ AC	1 1/4-in. pipe	1 1/4-in. pipe	N/A
★ AD	1 1/2-in. pipe	1 1/2-in. pipe	N/A
AE	N/A	Custom diameters (required for Root [Axxx] and tip [Bxxx] modifications)	N/A

**Table 9. Rosemount 114C Welded Ordering Information**

★The Standard offering represents the most common options. The starred options (★) should be selected for best delivery lead time. The Expanded offering is subject to additional delivery lead time.

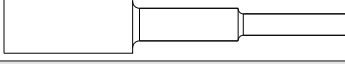
	DA	N/A	DIN 43772-4-7 (18 h7/3.5 mm bore/M14)	N/A	
	DB	N/A	DIN 43772-4-7 (24 h7/7.0 mm bore/M18)	N/A	
	DC	N/A	DIN 43772-4-7 (26 h7/7.0 mm bore/G <sup>1</sup> / <sub>2</sub> or M20)	N/A	
	DD	N/A	DIN 43772-4-7 (26 h7/9.0 mm bore/G <sup>1</sup> / <sub>2</sub> or M20)	N/A	
	DE	N/A	DIN 43772-4-7 (32 h11/11.0 mm bore/G <sup>3</sup> / <sub>4</sub> or M27)	N/A	
	DH	N/A	Custom diameters (required for root (Axxx) and tip ( Bxxx) modifications)	N/A	
	<b>Place # 13</b>	<b>Stem style</b>	<b>Details</b>	<b>Image</b>	
	★ 1	Straight	Minimum immersion length = 1-in. (25 mm)		60
	★ 2	Tapered	Minimum immersion length = 1-in. (25 mm)		60
	★ 3	Stepped	Minimum immersion length = 3-in. (75 mm)		60
	<b>Place #s 14-15</b>	<b>Thermowell material</b>	<b>Details</b>	<b>Ref. page</b>	
	★ SC	316/316L dual rated		61	
	SD	316/316L dual rated (NORSOK)	Must order the Q8 Material Certificate to get NORSOK documentation	62	
	★ SF	304/304L dual rated		61	
	★ CS	Carbon steel (A-105)		61	
	SG	316Ti SST		61	
	SL	310 SST		61	
	SM	321 SST		61	
	SN	321H SST		61	
	SR	904L SST		61	
	SP	347 SST		61	
	AB	Alloy B3		61	
	AC	Alloy C-276		61	
	AG	Alloy 20		61	
	AH	Alloy 400		61	
	AK	Alloy 600		61	
	AM	Alloy 601		61	
	AN	Alloy 625		61	
	AP	Alloy 800		61	
	AQ	Alloy 800H/HT		61	

**Table 9. Rosemount 114C Welded Ordering Information**

★The Standard offering represents the most common options. The starred options (★) should be selected for best delivery lead time. The Expanded offering is subject to additional delivery lead time.

	AR	Alloy 825		61
	AU	Alloy C-22		61
	AS	Alloy F44 Mo6		61
	MO	Molybdenum		61
	CA	Chrome-Moly Grade B-11/F-11 Class II		61
	CB	Chrome-Moly Grade B-22/ F-22 Class III		61
	CC	Chrome-Moly Grade F-91		61
	NK	Nickel 200		61
	TT	Titanium Grade 2		61
	DS	Super duplex SST Grade F-53		61
	DT	Super duplex – NORSOK	Must order the Q8 Material Certificate to get NORSOK documentation	62
	DU	Duplex 2205 Grade F51		61
	DV	Duplex 2205 – NORSOK	Must order the Q8 Material Certificate to get NORSOK documentation	62
<b>Place #s 16-18</b>	<b>Head length (H)</b>			<b>Ref. page</b>
★	xxx	xx.x-in., 1.75 to 11.25-in. in 1/4-in. increments (when ordered with dimension units code E) Example of a 6.25-in. length where the second decimal is dropped off: 062 (default head length = 1.75-in.)		63
★	xxx	xxx mm, 40 to 225 mm in 5-mm increments (when ordered with dimension units code M) Example of a 50 mm length: 050 (default head length = 45 mm)		63
<b>Place # 19</b>	<b>Instrument connection</b>	<b>Details</b>	<b>Image</b>	<b>Ref. page</b>
★	A	1/2-14 NPT	Female threads 	64
★	B	1/2-14 NPSM		64
	C	3/4-14 NPT		64
	D	M18 × 1.5p		64
	E	M20 × 1.5p		64
	F	M24 × 1.5p		64
	G	G 1/2-in. (BSPF)		64
	H	G 3/4-in. (BSPF)		64
	J	M27 × 2p		64
	K	M14 × 1.5p		64

Table 9. Rosemount 114C Welded Ordering Information

★The Standard offering represents the most common options. The starred options (★) should be selected for best delivery lead time. The Expanded offering is subject to additional delivery lead time.

### Options (include with selected model number)

Sensor/thermowell assemble to options			Details	Ref. page
★	XT	Hand tight assembly of sensor and thermowell	Sensor is threaded into thermowell but only hand tightened	65
Extended product warranty			Details	Ref. page
★	WR3	3-year limited warranty	This warranty option extends manufacturer's warranty to three or five years for manufacturer related defects	65
★	WR5	5-year limited warranty		65
Thermowell calculation			Details	Ref. page
★	R21	Thermowell calculation	Set of calculations to ensure thermowells are safe in certain process conditions	65
NACE certification			Details	Ref. page
★	Q35	NACE certification	Meets MR0175/ISO 15156 and MR0103 requirements	66
PMI testing			Details	Ref. page
	Q76	PMI testing	Verifies chemical composition of material	66
Material certification			Details	Ref. page
★	Q8	Material certification	Certificate for material conformance and traceability in accordance with EN 10204 type 3.1	67
Material tests			Details	Ref. page
	M01	Low temperature Charpy Test	Measures the low temperature ductility of the material	67
	M02	Ultrasonic material test	Examination of steel forgings for flaws and inclusions	67
Surface finish			Details	Ref. page
	Q16	Certification	Certificate showing measured surface finish values	68
	R14	Finish < Ra 0.3µm (12µin)	Improves surface roughness of thermowell	68
Electropolish			Details	Ref. page
	R20	Electropolish	Improves smoothness and surface quality	68
Hydrostatic internal pressure test			Details	Ref. page
★	Q85	Standard internal pressure test	Verifies internal structural integrity of thermowell	69
★	Q86	Externded internal pressure test	Same as standard internal pressure test but tested for twice as long	70

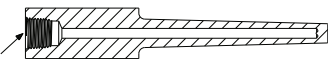
**Table 9. Rosemount 114C Welded Ordering Information**

★The Standard offering represents the most common options. The starred options (★) should be selected for best delivery lead time. The Expanded offering is subject to additional delivery lead time.

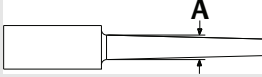
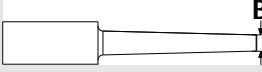
Canadian Registration Number		Details	Ref. page
Q17	Canadian Registration Number	Canadian approvals for all provinces (Approved materials in reference section)	70
<b>Dye penetration test</b>		<b>Details</b>	<b>Ref. page</b>
★ Q73	Dye penetration test	Checks quality of welds and material	70
<b>Wall thickness test</b>		<b>Details</b>	<b>Ref. page</b>
Q83	Ultrasonic test	Checks the bore concentricity of the thermowell	71
<b>Special cleaning</b>		<b>Details</b>	<b>Ref. page</b>
Q6	Special cleaning	Oxygen enriched environment cleaning per ASTM G93	71
<b>Thermowell markings</b>		<b>Details</b>	<b>Ref. page</b>
R40	Test markings on thermowell	External marking of the thermowell for specific tests (see reference page for list of tests)	71
<b>Spherical tip</b>		<b>Details</b>	<b>Ref. page</b>
R60	Spherical tip	Changes the flat tip to spherical	72
<b>Plug and chain</b>		<b>Details</b>	<b>Ref. page</b>
R06	Stainless steel	Protects thermowell threads when sensor is not installed	73
R23	Brass		73
<b>Vent hole</b>		<b>Details</b>	<b>Ref. page</b>
R11	Vent hole	Allows for the venting of a thermowell	73
<b>Root diameter (A)</b>			<b>Ref. page</b>
Axxx	x.xx-in., 0.36 to 3.15-in. in 0.01-in. increments (when ordered with dimension units code E) Examples: Code A040 = 0.4-in, Code A315 = 3.15-in.		80
Axxx	xx.xx mm, 10 to 80 mm in 0.5 mm increments (when ordered with dimension units code M) Examples: Code A100 = 10.0 mm, Code A755 = 75.5 mm		80
<b>Tip diameter (B)</b>			<b>Ref. page</b>
Bxxx	x.xx-in., 0.36 to 1.83-in. in 0.01-in. increments (when ordered with dimension units code E) Examples: Code B040 = 0.4-in, Code B180 = 1.80-in.		81
Bxxx	xx.xx mm, 10 to 46 mm in 0.5 mm. increments (when ordered with dimension units code M) Examples: Code B100 = 10.0 mm, Code B455 = 45.5 mm		81

**Table 9. Rosemount 114C Welded Ordering Information**

★The Standard offering represents the most common options. The starred options (★) should be selected for best delivery lead time. The Expanded offering is subject to additional delivery lead time.

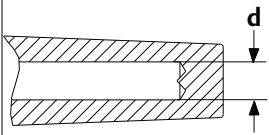
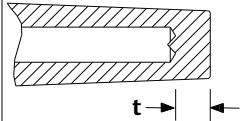
Non-standard bore diameter (d)		Details	Image	Ref. page
D01	0.276-in./7.0 mm	Standard = 0.26-in. (6.6 mm)		82
D03	0.138-in./3.5 mm			82
D04	0.386-in./9.8 mm			82
D05	0.354-in./9.0 mm			82
D06	0.433-in./11.0 mm			82
Non-standard tip thickness (t)		Details	Image	Ref. page
T01	0.197-in./5.0 mm	Standard = 0.25-in. (6.4 mm)		82
T02	0.236-in./6.0 mm			82

**Socket weld installation**

Socket weld thermowells are typically welded into a socket weld fitting. Welds should be designed according to the appropriate standards. It is important to order a head length (H) that leaves enough space so the instrument threads will not be deformed by welding at installation. The customer should also make sure the root diameter of the thermowell will fit through the inner diameter of the weld fitting.

**Note**

When specified in a thermowell calculation, the unsupported length for a socket weld thermowell is from the point of weld (B shown on Figure 21 on page 54) to the thermowell tip.

**Figure 21. Installation Components**

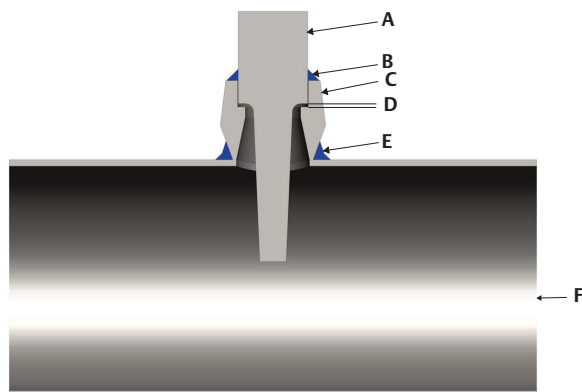

- A. Thermowell
- B. Weld
- C. Socket weld fitting
- D. 1/16-in. gap
- E. Weld
- F. Process

## Weld-in Type 4 thermowells according to DIN 43772

This section only defines the requirement necessary to provide a Type 4 thermowell according to the DIN 43772 Standard (for ordering information on weld-in thermowells outside the DIN Standard, see [Table 9 on page 49](#)).

The illustration below shows the breakdown of a model according to the DIN Standard:

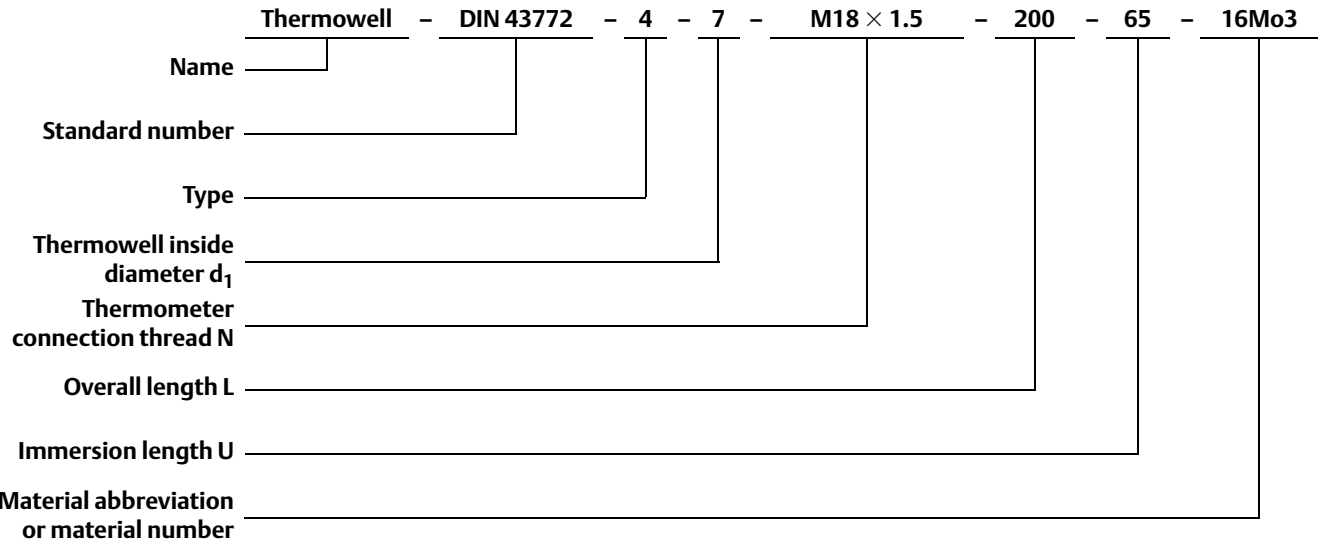

[Table 10](#), [Table 11](#), and [Table 12](#) show all required thermowell dimensions necessary to conform to DIN 43772 Type 4 and the relationship to the Rosemount 114C Thermowell.

### Ordering process

1. Select overall length (L) and immersion length (U) from [Table 10](#).

$U = 65 \text{ mm}$

$L = 200 \text{ mm}$

$H = L - U = 135 \text{ mm}$

Rosemount 114C = U = **0065**

Rosemount 114C = H = **135**

**Table 10. DIN Required Lengths**

Immersion length (U)		Overall length (L) (U + H)	Head length (H)	
(mm)	Code	(mm)	(mm)	Code
65	0065	110	45	045
65	0065	140	75	075
65	0065	200	135	135
125	0125	260	135	135
275	0275	410	135	135

2. Select process connection (PC), instrument connection (IC), and bore diameter (BD) from [Table 11](#).

$PC = 18 \text{ h7}/3.5 \text{ mm}$

$IC = M14 \times 1.5$

$BD = 3.5 \text{ mm}$

Rosemount 114C = 18 h7/3.5 mm = **DA**

Rosemount 114C = M14 × 1.5 = **K**

Rosemount 114C = 3.5 mm = **D03**

**Table 11. DIN Connection Information**

Process connection (PC)		Instrument connection (IC)		Bore diameter (BD)	
Type	Code	Internal threads	Code	(mm)	Code
18 h7	DA	M14 × 1.5	K	3.5	D03
24 h7	DB	M18 × 1.5	D	7.0	D01
26 h7	DC	G $\frac{1}{2}$ (BSPF)	G	7.0	D01

**Table 11. DIN Connection Information**

Process connection (PC)		Instrument connection (IC)		Bore diameter (BD)	
26 h7	DD	M20 × 1.5	E	9.0	D05
32 h11	DE	G <sup>3</sup> /4 (BSPF)	H	11.0	D06
32 h11	DE	M27 × 2	J	11.0	D06

- Determine thermowell material from [Table 12](#).  
Material = 316 Ti SST  
Rosemount 114C = 316 Ti SST= **SG**

**Table 12. DIN Material**

Thermowell material (M)	Material code
Molybdenum DIN 1.5415 EN 10273	MO
Chrome-Moly B-11 DIN 1.7335 EN 10273	CA
Chrome-Moly B-22 DIN 1.7380 EN 10273	CB
316 Ti SST DIN 1.4571 EN 10272	SG

- Apply to Rosemount 114C model as shown below:

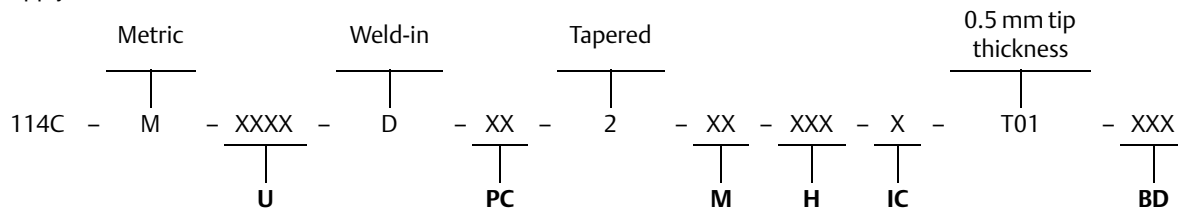

Resulting model code example: 114C-M-0065-D-DA-2-SG-135-K-T01-D03

**Figure 22. Weld Mounted Thermowell Drawings (Weld-in)**

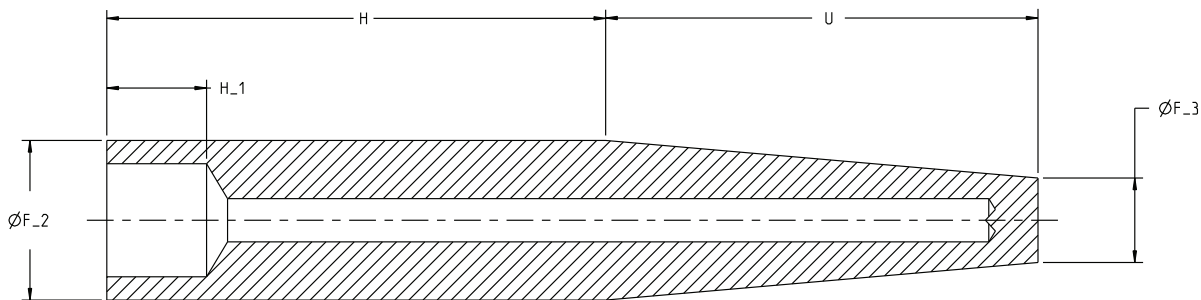

H. Head length  
Ø F<sub>2</sub>, Ø F<sub>3</sub>, and H<sub>1</sub>, refer to [Table 13](#).

U. Immersion length

**Table 13. DIN Weld Mounted Thermowells (Weld-in)<sup>(1)</sup>**

Code	Code D, welded (weld-in) style	Head diameter “Ø F <sub>2</sub> ”	Tip diameter “Ø F <sub>3</sub> ”	Thread length “H <sub>1</sub> ”
	Process connection			
DA	DIN 43772-4-7 (18 h7/3.5 mm bore/M14)	18 h7 (+0.000/-0.018 mm)	9 ±0.27	16
DB	DIN 43772-4-7 (24 h7/7 mm bore/M18)	24 h7 (+0.000/-0.021 mm)	12.5 ±0.38	16
DC	DIN 43772-4-7 (26 h7/7 mm bore/G <sup>1</sup> /2 or M20)	26 h7 (+0.000/-0.021 mm)	12.5 ±0.38	19
DD	DIN 43772-4-7 (26 h7/9 mm bore/G <sup>1</sup> /2 or M20)	26 h7 (+0.000/-0.021 mm)	15 ±0.38	19
DE	DIN 43772-4-7 (32 h11/11 mm bore/G <sup>3</sup> /4 or M27)	32 h11 (+0.000/-0.160 mm)	17 ±0.38	22

1. Dimensions are in millimeters.



## Welded thermowell drawings

Figure 23. Weld Mounted Thermowell Drawings (Socket Weld)<sup>(1)</sup>

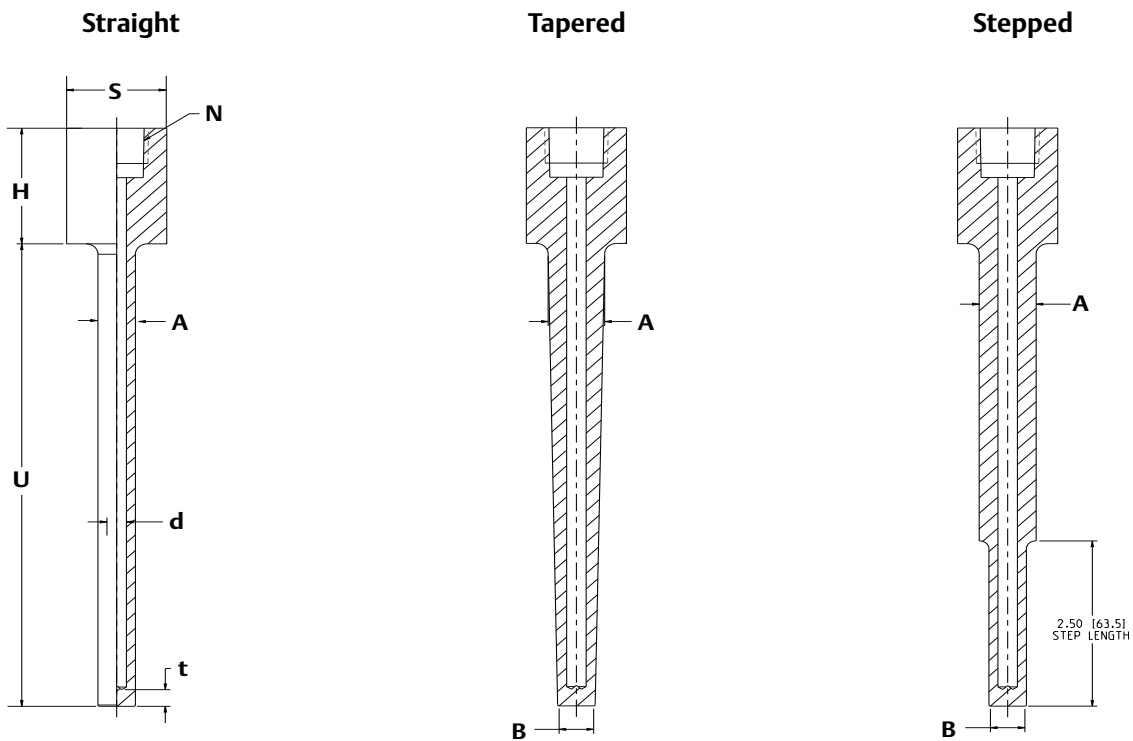

A. Root diameter  
 B. Tip diameter  
 H. Head length  
 N. Instrument connection

S. Socket size  
 U. Immersion length  
 d. Bore diameter  
 t. Tip thickness

Table 14. Weld Mounted Thermowells (Socket Weld)<sup>(1)</sup>

Code	Code W, welded mounting style	Socket size “ $\varnothing$ S”	Root diameter “ $\varnothing$ A”	Tip diameter “ $\varnothing$ B”
	Process connection			
AA	<sup>3</sup> / <sub>4</sub> -in. pipe	1.05 (26.67)	0.75 (19)	0.50 (12.7)
AB	1-in. pipe	1.32 (33.4)	0.75 (19)	0.50 (12.7)
AC	1 <sup>1</sup> / <sub>4</sub> -in. pipe	1.66 (42.16)	0.75 (19)	0.50 (12.7)
AD	1 <sup>1</sup> / <sub>2</sub> -in. pipe	1.90 (48.26)	0.75 (19)	0.50 (12.7)

1. Dimensions are in inches (millimeters).

1. Total length = U + H.

Figure 24. Weld Mounted Thermowell Drawings (Weld-in)<sup>(1)</sup>

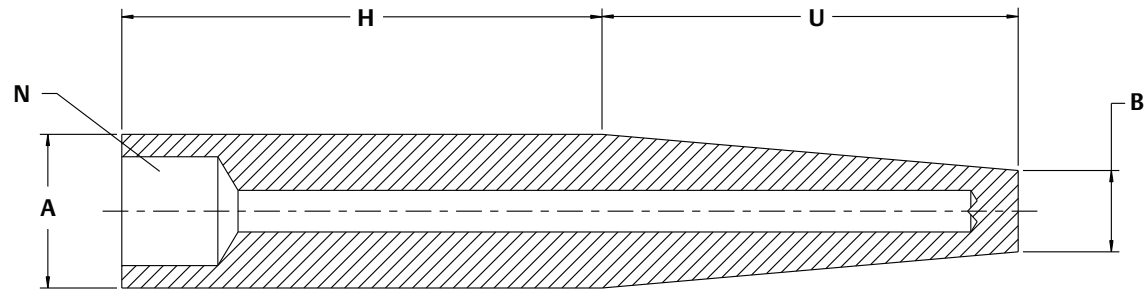

- A. Root diameter
- B. Tip diameter
- H. Head length
- N. Instrument connection
- U. Immersion length

Table 15. Weld Mounted Thermowells (Weld-in)<sup>(1)</sup>

Code	Code D, welded mounting style	Root diameter “Ø A”	Tip diameter “Ø B”
	Process connection		
AA	3/4-in. pipe	1.050 (26.67)	.748 (19)
AB	1-in. pipe	1.315 (33.40)	.846 (21.5)
AC	1 1/4-in. pipe	1.660 (42.16)	1.043 (26.5)
AD	1 1/2-in. pipe	1.900 (48.26)	1.250 (31.75)
AE	Custom	Specified by design modifier “AXXX”	Specified by design modifier “BXXX”

1. Dimensions are in inches (millimeters).

1. Total length = U + H.

# Ordering information detail

## Dimension units

[Back to Threaded ordering table](#)

[Back to Flanged ordering table](#)

[Back to Van Stone ordering table](#)

[Back to Welded ordering table](#)

The Rosemount 114C Thermowell has the flexibility to be specified in either inches (E) or millimeters (M).

### English units (inches)

If English is selected, all lengths will be in inches.

### Metric

If metric is selected, all lengths will be in millimeters.

## Immersion length (U)

[Back to Threaded ordering table](#)

[Back to Flanged ordering table](#)

[Back to Van Stone ordering table](#)

[Back to Welded ordering table](#)

The immersion length normally refers to the length of the thermowell stem beginning underneath the process connection to the tip of the thermowell. This length is typically specified by the process designer but the general rule is at least one-third or one-half the pipe diameter. Thermowells longer than 42-in. will be required to have an internal pressure test (Q85) performed to ensure the internal cavity integrity has not been compromised. Parallel thread thermowells have a U length that actually includes the process threads thus requiring an extra 1-in. (25 mm) for min. U length.

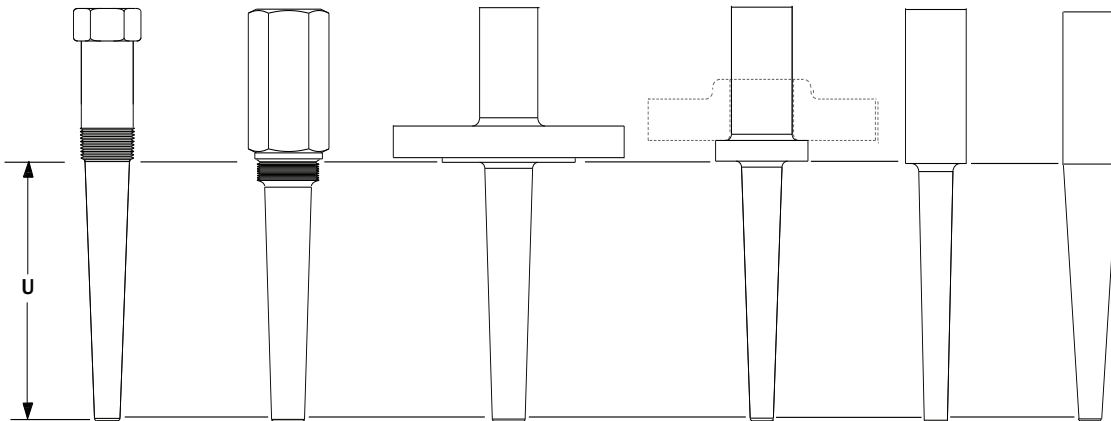

**Table 16. Minimum Immersion Length by Profile Style**

Profile	Minimum length	Minimum length (parallel threads)
Straight	1-in. (25 mm)	2-in. (50 mm)
Tapered	1-in. (25 mm)	2-in. (50 mm)
Stepped	3 -in. (75 mm)	4-in. (100 mm)

**Note**

Long-length thermowells are those longer than 42-in. (1065 mm) and may be manufactured from two or three pieces of bar stock.

## Stem style

[Back to Threaded ordering table](#)

[Back to Flanged ordering table](#)

[Back to Van Stone ordering table](#)

[Back to Welded ordering table](#)

### Straight style thermowells (1)

Straight style thermowells have the same diameter along the entire immersion length. They present the largest profile to the process medium and have the highest drag force compared to other styles with the same root diameter. Because of the large tip diameter, there is more mass to heat which slows the thermal response of the measurement assembly. The minimum immersion length (U) allowed with this profile is 1-in. (25 mm) except for parallel threaded thermowells that have a minimum immersion of 2-in. (50 mm).

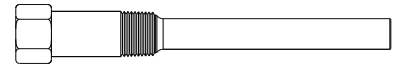

### Tapered style thermowells (2)

Tapered style thermowells have an outside diameter that decreases uniformly from root to tip. For the same root diameter, this design represents a good compromise between straight and stepped thermowells. Its drag will be less than a straight style, but greater than a stepped style. The response time will be faster than a straight style and slower than a stepped style. The two general forms of a tapered stem are uniform (tapered from root to tip) and non-uniform (straight portion followed by tapered portion). Because of its profile shape, it is a good compromise for strength between the two other styles. It is the common choice for high velocity flow applications where the flow forces typically are too great to use a stepped well. The tapered design has faster response than the straight style offering an optimal balance of strength and response time factors. The minimum immersion length (U) allowed with this profile is 1-in. (25 mm) except for parallel threaded thermowells that have a minimum immersion of 2-in. (50 mm). The maximum length allowed for the tapered profile is; Immersion length (U) + Head length (H) <= 4-in. (1067 mm)



### Stepped style thermowells (3)

Stepped style thermowells have two straight sections with the smaller diameter straight section at the tip. For the same root diameter as a straight profile thermowell, this design has less profile exposure to the flowing process and exhibits less drag force and quicker response time due to the smaller mass at the tip. In general, stepped thermowells will have thinner walls. By the geometry of its design, the stepped well has a higher natural frequency than the other styles with the same root diameter, and is less susceptible to vibration induced failure. Since this design has less material at the tip, its considered the best thermowell for fast time response. The minimum immersion length (U) allowed with this profile is 3-in. (75 mm) except for parallel threaded thermowells that have a minimum immersion of 4-in. (100 mm).

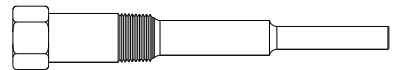

## Thermowell material

[Back to Threaded ordering table](#)

[Back to Flanged ordering table](#)

[Back to Van Stone ordering table](#)

[Back to Welded ordering table](#)

The material of construction is typically the first consideration in choosing a thermowell for any given application. Three factors affect the choice of material:

1. Chemical compatibility with the process media to which the thermowell will be exposed.
2. Temperature limits of the material
3. Compatibility with the process piping material to ensure solid, non-corroding welds and junctions.

It is important the thermowell conforms to the design specs of the pipe or vessel it will be inserted into to ensure structural and material compatibility. The original process design most likely included temperature, pressure, and corrosive considerations as well as cleaning procedures, agency approvals required, and conformance with codes or standards. Since an installed thermowell essentially becomes part of the process, these original design considerations also apply to the thermowell and will drive the thermowell material of construction and mounting type selection. International pressure vessel codes are explicit about the types of materials and methods of construction allowed.

**Table 17. Thermowell Materials**

Code	Thermowell material	Flange material	Code	Thermowell material	Flange material
SC	316/316L SST UNS S31600/S31603 ASTM A479	316/316L SST UNS S31600/S31603 ASTM A182 or A240	SP	347 SST UNS S34700 ASTM A479 DIN 1.4550	347 SST UNS S34700 ASTM A182 or A240 DIN 1.4550
SD <sup>(1)</sup>	316/316L SST dual rated (NORSOK) UNS S31600/S31603 ASTM A479 NORSOK M-630 MDS D57	316/316L SST dual rated (NORSOK) <sup>(1)</sup> UNS S31600/S31603 ASTM A182 NORSOK M-630 MDS D54	AB	Alloy B3 UNS N10001 ASTM B335	Alloy B3 UNS N10001 ASTM B333
SF	304/304L SST UNS S30400/S30403 ASTM A479	304/304L SST UNS S30400/S30403 ASTM A182 or A240	AC	Alloy C-276 UNS N10276 ASTM B574	Alloy C-276 UNS N10276 ASTM B462 or B575
SG	316T i SST UNS S31635 ASTM A479	316T i SST UNS S31635 ASTM A182	AD	Alloy C-4 UNS N06455 ASTM B574	304/304L SST UNS S30400/S30403 ASTM A182 or A240
SH <sup>(2)</sup>	316/316L SST with Tantalum sheath UNS S31600/S31603 ASTM A479	316/316L SST with Tantalum sheath UNS S31600/S31603 ASTM A182 or A240	AE	Alloy C-22 UNS N06022 ASTM B574	304/304L SST UNS S30400/S30403 ASTM A182 or A240
	Tantalum sheath UNS R05252		AF	Alloy C-22 UNS N06022 ASTM B574	316/316L SST UNS S31600/S31603 ASTM A182 or A240
SJ	316/316L SST w / PFA coating UNS S31600/S31603 ASTM A479	316/ 316L SST w / PFA coating UNS S31600/S31603 ASTM A182 or A240	AG	Alloy 20 UNS N08020 ASTM B473	Alloy 20 UNS N08020 ASTM B462 or B463
SK	304/304L SST with PTFE coating UNS S30400/S30403 ASTM A479	304/304L SST with PTFE coating UNS S30400/S30403 ASTM A182 or A240	AH	Alloy 400 UNS N04400 ASTM B164	Alloy 400 UNS N04400 ASTM B564 or B127
SL	310 SST UNS S31008 ASTM A479	310 SST UNS S31008 ASTM A182 or A240	AJ	Alloy 400 UNS N04400 ASTM B164	304/304L SST UNS S30400/S30403 ASTM A182 or A240
SM	321 SST UNS S32100 ASTM A479	321 SST UNS S32100 ASTM A182 or A240	AK	Alloy 600 UNS N06600 ASTM B166	Alloy 600 UNS N06600 ASTM B564 or B168
SN	321H SST UNS S32109 ASTM A479 DIN 1.4	321H SST UNS S32109 ASTM A182 or A240 DN 1.4878	AL	Alloy 600 UNS N06600 ASTM B166	304/304L SST UNS S30400/S30403 ASTM A182 or A240
SR	904L SST UNS N08904 ASTM A479 DIN 1.4539	904L SST UNS N08904 ASTM A240 DIN 1.4539	AM	Alloy 601 UNS N06601 ASTM B166 DIN 2.4851	Alloy 601 UNS N06601 ASTM B168 or B564 DIN 2.4851

Table 17. Thermowell Materials

Code	Thermowell material	Flange material	Code	Thermowell material	Flange material
AN	Alloy 625 UNS N06625 ASTM B446 DIN 2.4856	Alloy 625 UNS N06625 ASTM B443 or B564 DIN 2.4856	DU	Duplex 2205 UNS 31803 ASTM A479 GR F51	Duplex 2205 UNS 31803 ASTM A182 GR F51 or A240
AP	Alloy 800 UNS N08800 ASTM B408 DIN 1.4876	Alloy 800 UNS N08800 ASTM B409 or B564 DIN 1.4876	CC	Chrome-Moly Grade F-91 UNS K90901 ASTM A182	Chrome-Moly Grade F-91 UNS K90901 ASTM A182 GR F-9, A217 GR C12A, or A387 GR 91 CL2
AQ	Alloy 800H/HT UNS N08811 ASTM B408 DIN 1.4959	Alloy 800H/HT UNS N08811 ASTM B409 or B564 DIN 1.4959	NK	Nickel 200 UNS N02200 ASTM B160	Nickel 200 UNS N02200 ASTM B162 or B564
AR	Alloy 825 UNS N08825 ASTM B425 DIN 2.4858	Alloy 825 UNS N08825 ASTM B424 or B564 DIN 2.4858	MD	Molybdenum UNS R03600 ASTM B387	Molybdenum UNS R03630 ASTM A204 or B386
AU	Alloy C-22 UNS N06022 ASTM B574 DIN 2.4602	Alloy C-22 UNS N06022 ASTM B567 or B575 DIN 2.4602	CA	Chrome-Moly Grade B-11 UNS K11797 ASTM A739 GR B-11	Chrome-Moly Grade F-11 UNS K11572 ASTM A182 GR F-11 CL2 or A387 GR11 CL2
AS	Alloy F44 Mo6 UNS S31254 ASTM A479 DIN 1.4547	Alloy F44 Mo6 UNS S31254 ASTM A182 or A240 DIN 1.4547	CB	Chrome-Moly Grade B-22 UNS K21390 ASTM A739 GR B-22	Chrome-Moly Grade F-22 UNS K21590 ASTM A182 GR F-22 CL3, A217 GR WC9, or A387 GR22 CL2
CS	Carbon steel UNS K03504 ASTM A105	Carbon steel UNS K03504 ASTM A105, A216 GR WCB, or A515 GR 70	DT <sup>(1)</sup>	Super duplex (NORSOK) UNS 32750 ASTM A479 GR F53 NORSOK M-630 MDS D57	Duplex 2205 (NORSOK) UNS 31803 ASTM A182 GR F53 NORSOK M-630 MDS D54
TT	Titanium grade 2 UNS R50400 ASTM B348 GR 2	Titanium grade 2 UNS R50400 ASTM B381 GR 2	DV <sup>(1)</sup>	Duplex 2205 (NORSOK) UNS 31803 ASTM A479 GR F51 NORSOK M-630 MDS D47	Duplex 2205 (NORSOK) UNS 31803 ASTM A182 GR F51 NORSOK M-630 MDS D44
DS	Super duplex UNS 32750 ASTM A479 GR F53	Super duplex UNS 32750 ASTM A182 GR F53 or A240	MO	Molybdenum UNS R03600 ASTM B387 DIN 1.5415 EN 10273	Molybdenum UNS R03630 ASTM A204 or B386 DIN 1.5415 EN 10222-2

1. Material supplier qualified per NORSOK M-650; material qualified per NORSOK M-630.
2. Sheath thickness = 0.01-in. (0.38 mm).

## NORSOK

Rosemount 114 Thermowell ordered with NORSOK will have raw material from a NORSOK M-650 approved supplier, material approver per NORSOK M-630 datasheet, and flange welding qualified to NORSOK M-601. The NORSOK material will also meet requirements of NACE MR0175/ISO 15156.

Q8 should be ordered to receive the MTR. The MTR will come with an M-650 Qualification Test Record (QTR) cover sheet. Additional testing required by the M-630 datasheet will be included in the MTR.

Some of the required testing for NORSOK Duplex in addition to ASTM requirements;

- Micrographic examination at 400 to 500× magnification
- Ferrite content analysis according to ASTM E 562 or by image analysis according to ASTM E 1245. Ferrite content shall be within 35–55 percent.
- Charpy V-notch testing according to ASTM A 370 at –46 °C. Minimum absorbed energy shall be 45 J average and 35 J single.
- Corrosion testing according to ASTM G 48 Method A. No pitting at 20× magnification; Weight loss shall be less than 4 g/m<sup>2</sup>.

Full details of the material requirements can be found in the ASTM and NORSOK M-630 standards.

## Head length (H)

[Back to Threaded ordering table](#)

[Back to Flanged ordering table](#)

[Back to Van Stone ordering table](#)

[Back to Welded ordering table](#)

Head length is the distance from the bottom of the process connection to the top of the thermowell. Each style has a minimum head length; the length specified must meet or exceed that minimum. It is shown below for all process connection styles.

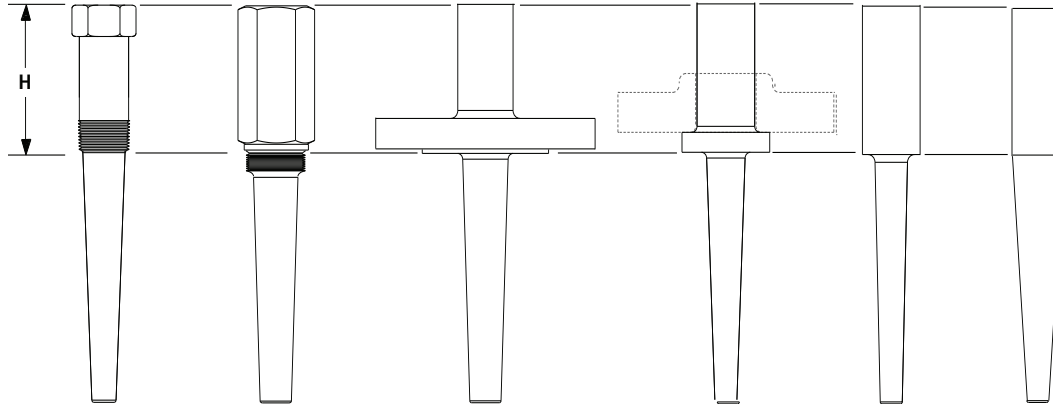

**Note**

The industry standard minimum head length for flanged and Van Stone thermowells with connections under Class 900 (ASME B16.5) or PN 100 (EN 1092-1) is 2.25-in. (60 mm).

**Table 18. Recommended Minimum Head Length<sup>(1)</sup>**

Process connection	Minimum head length (H)
Threaded	1.75 (45)
Welded	

1. Dimensions are in inches (millimeters).

**Table 19. Recommended Minimum Head Length by Connection Class for ASME B16.5<sup>(1)</sup>**

Connection size	Connection class				
	150	300	400/600	900/1500	2500
<b>Flanged</b>					
<sup>3</sup> / <sub>4</sub>	N/A	1.75 (45)	N/A	N/A	N/A
1	1.75 (45)	2.00 (50)	2.00 (50)	2.50 (65)	N/A
1 <sup>1</sup> / <sub>2</sub>	1.75 (45)	2.00 (50)	2.00 (50)	2.50 (65)	3.00 (75)
2	1.75 (45)	2.00 (50)	2.00 (50)	2.75 (70)	3.25 (80)
3	2.00 (50)	N/A	N/A	N/A	N/A
4	2.00 (50)	N/A	N/A	N/A	N/A
6	2.00 (50)	N/A	N/A	N/A	N/A
<b>Flanged with RTJ</b>					
<sup>3</sup> / <sub>4</sub>	N/A	2.00 (50)	N/A	N/A	N/A
1	1.75 (45)	2.00 (50)	2.00 (50)	2.50 (65)	N/A
1 <sup>1</sup> / <sub>2</sub>	2.00 (50)	2.00 (50)	2.00 (50)	2.50 (65)	3.25 (80)
2	2.00 (50)	2.00 (50)	2.00 (50)	2.75 (70)	350 (85)
3	2.25 (60)	N/A	N/A	N/A	N/A
4	2.25 (60)	N/A	N/A	N/A	N/A
6	2.25 (60)	N/A	N/A	N/A	N/A

**Table 19. Recommended Minimum Head Length by Connection Class for ASME B16.5<sup>(1)</sup>**

Connection size	Connection class				
<b>Van Stone</b>	<b>150</b>	<b>300</b>	<b>400/600</b>	<b>900/1500</b>	<b>2500</b>
1	1.75 (45)	1.75 (45)	1.75 (45)	2.00 (50)	2.25 (60)
1½	1.75 (45)	1.75 (45)	1.75 (45)	2.25 (60)	2.75 (70)
2	1.75 (45)	1.75 (45)	2.00 (50)	2.75 (70)	3.25 (80)
<b>Van Stone with RTJ</b>	<b>150</b>	<b>300</b>	<b>400/600</b>	<b>900/1500</b>	<b>2500</b>
1	1.75 (45)	1.75 (45)	2.25 (60)	2.25 (60)	2.50 (65)
1½	1.75 (45)	2.00 (50)	2.00 (50)	2.50 (65)	3.00 (75)
2	1.75 (45)	2.00 (50)	2.25 (60)	3.00 (75)	3.50 (90)

1. Dimensions are in inches (millimeters).

**Table 20. Recommended Minimum Head Length by Connection Class for EN 1092-1<sup>(1)</sup>**

Connection size	Connection class				
<b>Flanged</b>	<b>PN 2.5/6</b>	<b>PN 10/16</b>	<b>PN 25/40</b>	<b>PN 63</b>	<b>PN 100</b>
DN 20	40	45		50	
DN 25	40	45		50	
DN 40	40	45		50	
DN 50	40	45		55	60
DN 65	40	45	50	55	60
DN 80	40	45	50	55	60
DN 100	40	45	50	55	60

1. Dimensions are in millimeters.

## Instrument connection

[Back to Threaded ordering table](#)

[Back to Flanged ordering table](#)

[Back to Van Stone ordering table](#)

[Back to Welded ordering table](#)

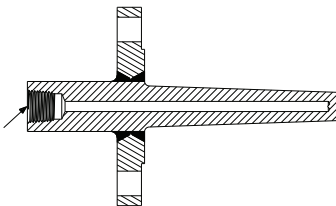
Thread	Specification	Internal thread
½-14 NPT	SAE-AS 71082	
½-14 NPSM	ASME B1.20.1, 8 threads minimum	
¾-14 NPT	SAE-AS 71082	
M18 × 1.5p	BS 3643	
M20 × 1.5p		
M24 × 1.5p		
M27 × 2p		
M14 × 1.5p		
G½-in. (BSPF)	ISO 228/1 (BS 2779)	
G¾-in. (BSPF)	ISO 228/1 (BS 2779)	



## Sensor/thermowell assemble to options (XT, XW)

[Back to Threaded ordering table](#)

[Back to Flanged ordering table](#)

[Back to Van Stone ordering table](#)

[Back to Welded ordering table](#)

### XT

This option is selected when a Rosemount 214C Sensor is ordered with the Rosemount 114C Thermowell. This ensures the sensor is threaded into the thermowell, but only hand tightened.

### XW

This option is selected when a Rosemount 214C Sensor is ordered with the Rosemount 114C Thermowell. This ensures the sensor is threaded into the thermowell and torqued for a process-ready installation.

## Extended product warranty (WR3, WR5)

[Back to Threaded ordering table](#)

[Back to Flanged ordering table](#)

[Back to Van Stone ordering table](#)

[Back to Welded ordering table](#)

The extended product warranty options are available in three or five year coverage plans. In the model string, order option codes WR3 for a three year extended warranty or WR5 for a five year warranty. This coverage is an extension of the manufacturer's limited warranty and states that the goods manufactured or services provided by seller will be free from defects in materials or workmanship under normal use and care until the expiration of the applicable warranty period.

## Thermowell calculation (R21)

[Back to Threaded ordering table](#)

[Back to Flanged ordering table](#)

[Back to Van Stone ordering table](#)

[Back to Welded ordering table](#)

The ASME PTC 19.3TW is internationally recognized as a mechanical design standard yielding reliable thermowell service in a wide range of temperature measurement applications. It includes evaluation of stresses applied to a barstock thermowell as installed in a process based on the design, material, mounting method, and process conditions. The documentation provided will detail the process information, thermowell geometry, and comprehensive calculation analysis. It will also provide an acceptable or unacceptable statement based on the analysis.

There are four quantitative criteria in ASME PTC 19.3 TW for a thermowell to be found acceptable for a particular set of process conditions:

- **Frequency Limit:** the resonant frequency of the thermowell must be sufficiently high so that destructive oscillations are not excited by the fluid flow.
- **Dynamic Stress Limit:** the maximum primary dynamic stress must not exceed the allowable fatigue stress limit. If the design requires that the thermowell pass through the in-line resonance to get to the operating conditions, there is an additional fatigue check at resonance.
- **Static Stress Limit:** the maximum steady-state stress on the thermowell must not exceed the allowable stress, as determined by the Von Mises criteria.
- **Hydrostatic Pressure Limit:** the external pressure must not exceed the pressure ratings of the thermowell tip, shank, and flange (or threads).

In addition, the suitability of the thermowell material for the process environment must be considered. This means the designer must evaluate how corrosion and erosion affects the thermowell as well as how exposure to the process conditions affects material properties.

For detailed information about this standard, refer to the Thermowell Calculations [White Paper](#). Emerson advises that all thermowells should have a wake frequency calculation performed to ensure they are suitable for the process conditions in their application. Emerson assumes that the customer has either done their own calculations or understands the risks of not having calculations done if this option is not requested.

## NACE certification (Q35)

[Back to Threaded ordering table](#)

[Back to Flanged ordering table](#)

[Back to Van Stone ordering table](#)

[Back to Welded ordering table](#)

This option certifies that thermowell materials used are compliant to NACE MR0175/ISO 15156 and NACE MR0103. The material certification provided will list compliance to the referenced standard.

Material code	NACE certified material
SC	316/316L Dual Rated
SF	304/304L Dual Rated
SL	310 SST
SM	321 SST
SN	321H SST
SP	347 SST
SR	904L SST
AB	Alloy B3
AC	Alloy C-276
AG	Alloy 20
AH	Alloy 400

Material code	NACE certified material
AK	Alloy 600
AM	Alloy 601
AN	Alloy 625
AR	Alloy 800
AQ	Alloy 800H/HT
AR	Alloy 825
AS	Alloy F44 Mo6
AU	Alloy C-22
CA	Chrome-Moly Grade B-11/F-11 Class II
CB	Chrome-Moly Grade B-22/ F-22 Class III

## PMI testing (Q76)

[Back to Threaded ordering table](#)

[Back to Flanged ordering table](#)

[Back to Van Stone ordering table](#)

[Back to Welded ordering table](#)

Positive Material Identification (PMI) is a test that verifies the thermowell material is as specified by the Rosemount 114C model code. X-ray/radiograph fluorescence (XRF) is used to provide elemental analysis in a nondestructive manner. The certificate will provide PMI results in comparison with the applicable material standards for each individual thermowell and state the reference standard. Two points are provided on flanges. All other thermowell components (including welds) will have a single point. XRF will not detect carbon in steels. PMI can be marked on the thermowell by choosing option R40. Due to type of technology used carbon steel material is exempt from this testing.

## Material certification (Q8)

[Back to Threaded ordering table](#)

[Back to Flanged ordering table](#)

[Back to Van Stone ordering table](#)

[Back to Welded ordering table](#)

Material certificate and traceability in accordance with EN 10204 Type 3.1 Inspection Certificate. The certificate provided will document the heat code, chemical analysis, and testing required by material standards.

## Low temperature Charpy test (M01)

[Back to Threaded ordering table](#)

[Back to Flanged ordering table](#)

[Back to Van Stone ordering table](#)

[Back to Welded ordering table](#)

Test is performed in accordance with ASTM A370 and report will be include in the Material Traceability Report (Q8). This report must be ordered if any documentation is required. Charpy test will be done to check toughness of the raw bar and flange material used for the construction of the thermowell. The table below shows the material available with the option, test temperature, and acceptance criteria.

Material	Material codes	Charpy temperature	Acceptance impact value
Duplex	DS – Super duplex DT – Super duplex (NORSOK) DU – Duplex DV – Duplex (NORSOK)	–58 °F (–50 °C)	Average: 45 J (33 ft-lb) Minimum: 35 J (26 ft-lb)
300 Series SST	SC – 316/316L SST SD – 316/316L SST (NORSOK) SF – 304/304L SG – 316 Ti SH – 316/316L with tantalum sheath SJ – 316/316L with PFA coating SK – 304/304L with PTFE coating SM – 321 SST	–321 °F (–196 °C)	Average: 60 J (44 ft-lb) Minimum: 55 J (41 ft-lb)

When ordering this option with any weld documentation (Q66-Q68), note that there is a separate set of documents needed to meet the test requirements. There are Q66-68 weld documents specifically for M01 tested material.

## Ultrasonic material test (M02)

[Back to Threaded ordering table](#)

[Back to Flanged ordering table](#)

[Back to Van Stone ordering table](#)

[Back to Welded ordering table](#)

Ultrasonic examination will be done to check quality of the raw bar and flange material used for thermowell construction. The testing shall be performed in accordance with procedures specified in ASTM A388 by a Level 2 inspector. Calibration and acceptance criteria shall be per API 6A.

## Surface finish certification (Q16)

[Back to Threaded ordering table](#)

[Back to Flanged ordering table](#)

[Back to Van Stone ordering table](#)

[Back to Welded ordering table](#)

Thermowell surface finish is typically done to remove all the burrs and sharp edges which smooths the thermowell stem surface. The Rosemount 114C comes with a standard surface finish of T32  $\mu$  in. CLA N6 (0.8  $\mu$ m Ra) or better. This option provides a certificate that documents the maximum surface finish reading for stem and flange (when applicable) and a pass/fail statement. Improved surface finish options are also available for the Rosemount 114C (see options R14 and R20).

## Surface finish <math>\leq Ra 0.3 \mu m (12 \mu in)</math> (R14)

[Back to Threaded ordering table](#)

[Back to Flanged ordering table](#)

[Back to Van Stone ordering table](#)

[Back to Welded ordering table](#)

Improves surface finish to be less than Ra 0.3  $\mu$ m. An improved surface finish will increase corrosion resistance and make the thermowell easier to clean. This is common in sanitary applications.

## Electropolish (R20)

[Back to Threaded ordering table](#)

[Back to Flanged ordering table](#)

[Back to Van Stone ordering table](#)

[Back to Welded ordering table](#)

The electropolish process uses a combination of electrical current and chemicals to improve the surface finish. The surface will appear shiny and polished. It can have an advantage over mechanical polishing because there is no cold work involved that can lead to scratches, strains, metal debris, and embedded abrasives on the surface. An improved surface finish will increase corrosion resistance and make the thermowell easier to clean. This is common in sanitary applications.

## Stepped instrument threads (R61)

[Back to Van Stone ordering table](#)

Threads are recessed and begin 0.35-in. (9 mm) from the top of the face of the thermowell's instrument connection entry as shown below:

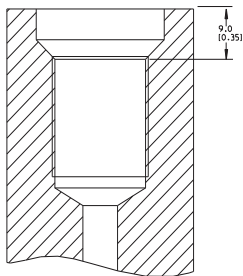

## Standard external hydrostatic pressure test (Q5)

[Back to Threaded ordering table](#)

[Back to Flanged ordering table](#)

[Back to Van Stone ordering table](#)

Thermowells are tested at room temperature for 10 minutes. Water is certified to have a chlorine content of less than 30 ppm. The certificate will document the chlorine content, hydrostatic test pressure level, duration, and test results. The pressure rating (in psi) for the different thermowell mounting styles is given below.

## Flanged and Van Stone

Hydrostatic pressure test levels are in accordance with ASME B16.5. When the table below and the standard conflict, the standard shall govern.

Flange class (lb)	Thermowell material (psi)					
	NK	AH, AQ, TT	SC, SD, SF, SG, SH, SJ, SK, SL, SM, SN, SP, AP, AM, AD, AE, AF, AJ, AL	CS	SR	AG, AK, CA, AB, AC, CB, CC, DU, DT, DV, AN, AR, AU, AS, MO, DS
150	300	350	425	450	450	450
300	725	900	1100	1125	1125	1125
600	1450	1800	2175	2225	2250	2250
1500 (900)	3600	4500	5400	5575	5600	5625
2500	6000	7500	9000	9275	9300	9375

## DIN flanged thermowells

Table 21. External Pressure Test–DIN

DIN flanged thermowells	
Nominal pressure (bar)	Test pressure (bar)
16	40
40	100
100	250
Test to 2.5× nominal pressure rating	

## Threaded thermowells

1500 psi

## Extended external hydrostatic pressure test (Q9)

[Back to Threaded ordering table](#)

[Back to Flanged ordering table](#)

[Back to Van Stone ordering table](#)

Thermowells are tested at room temperature for 20 minutes. Water is certified to have a chlorine content of less than 30 ppm. The certificate will document the chlorine content, hydrostatic test pressure level, duration, and test results. The pressure rating (in psi) for the different thermowell mounting styles are the same as the standard external pressure test.

## Standard internal hydrostatic pressure test (Q85)

[Back to Threaded ordering table](#)

[Back to Flanged ordering table](#)

[Back to Van Stone ordering table](#)

[Back to Welded ordering table](#)

This test is performed at room temperature for a minimum of 10 minutes to 3000 PSI. The water used here is certified to ensure a chloride content of less than 30 PPM. The certificate provided will document the chloride content, hydrostatic test level, duration, and results. Thermowells longer than 42-in. will be required to have an internal pressure test (Q85) performed to ensure the internal cavity integrity has not been compromised.

## Extended internal hydrostatic pressure test (Q86)

[Back to Threaded ordering table](#)

[Back to Flanged ordering table](#)

[Back to Van Stone ordering table](#)

[Back to Welded ordering table](#)

This test is performed at room temperature for a minimum of 20 minutes to 3000 PSI. The water used here is certified to ensure a chloride content of less than 30 PPM. The certificate provided will document the chloride content, hydrostatic test level, duration, and results. Thermowells longer than 42-in. will be required to have a standard internal pressure test (Q85) performed to ensure the internal cavity integrity has not been compromised.

## Canadian registration number (Q17)

[Back to Threaded ordering table](#)

[Back to Flanged ordering table](#)

[Back to Van Stone ordering table](#)

[Back to Welded ordering table](#)

Any pressure vessel, piping system, or fitting used in Canada is required by law to have a CRN (Canadian Registration Number). This ensures all pressure vessels, piping systems, and fittings are built under appropriate quality control programs. This CRN is for all Canadian provinces but the end destination province still needs to be known during the order process.

Material code	CRN approved material
SC	316/316L Dual Rated
SF	304/304L Dual Rated
SH	316 SST with Tantalum Sheath
SJ	316L SST with PFA Coating
SK	304 SST with PTFE Coating
SL	310 SST
SM	321 SST
SN	321H SST
SP	347 SST
AB	Alloy B3
AC	Alloy C-276
AG	Alloy 20
AH	Alloy 400
AJ	Alloy 400 (with 304 SST Flange)

Material code	CRN approved material
AK	Alloy 600
AL	Alloy 600 (with 304 SST Flange)
AM	Alloy C-22
AN	Alloy 625
AP	Alloy 800
AQ	Alloy 800H/HT
AR	Alloy 825
CA	Chrome-Moly Grade B-11/F-11 Class II
CB	Chrome-Moly Grade B-22/F-22 Class III
CC	Chrome-Moly Grade F-91
CS	Carbon Steel (A-105)
TT	Titanium Grade 2
DU	Duplex 2205 Grade F51

## Dye penetration test (Q73)

[Back to Threaded ordering table](#)

[Back to Flanged ordering table](#)

[Back to Van Stone ordering table](#)

[Back to Welded ordering table](#)

Dye or liquid penetration testings are performed by ASME Level II or III trained inspectors. These tests are all done in accordance to ASME Section V, Article 6 with an acceptance criteria per ASME Section III, Div 1 NB-2546. The certificate will document the inspectors name, dye penetration acceptance criteria, and test result.

## Wall thickness test (Q83)

[Back to Threaded ordering table](#)

[Back to Flanged ordering table](#)

[Back to Van Stone ordering table](#)

[Back to Welded ordering table](#)

Ultrasonic examination performed to check stem wall thickness. Min and max wall thickness measurements shall be recorded 25 mm or 1-in. from the thermowell tip. Bore position should be 10 percent of minimum stem wall thickness at nominal dimensions (see image below).

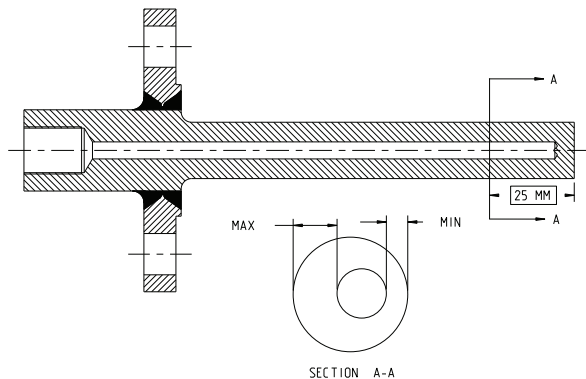

## Special cleaning (Q6)

[Back to Threaded ordering table](#)

[Back to Flanged ordering table](#)

[Back to Van Stone ordering table](#)

[Back to Welded ordering table](#)

Special cleaning for oxygen/special service to be performed in accordance to ASTM G93. The procedure to be qualified using ASTM G93 Type II quantitative tests. The documentation provided for this test will have a compliance statement to ASTM G93. All cleaned thermowells will come in a sealed plastic bag to prevent contamination. Not available with carbon steel or any coated material.

## Thermowell markings (R40)

[Back to Threaded ordering table](#)

[Back to Flanged ordering table](#)

[Back to Van Stone ordering table](#)

[Back to Welded ordering table](#)

This options provides the ability to have certain test markings on the thermowell. Below are the tests available for this option.

- Q5 — Standard external pressure tests the values and units
- Q76 — PMI will be marked on the head length portion of the thermowell and on the top of the flange if applicable
- Q9 — Extended external pressure test values and units
- Q85 — Standard internal pressure tests values and units
- Q86 — Extended internal pressure tests values and units

## Welding procedure qualification record (Q66)

[Back to Flanged ordering table](#)

A record of a test performed and tested to ensure that the procedure will produce a good weld. Documentation to be supplied in accordance with QW-200.2 ASME Section IX.

The records for thermowells with option M01 (low temperature charpy) are different and are highlighted when choosing to ensure the right documents are submitted to the customer.

## Welder performance qualifications (Q67)

[Back to Flanged ordering table](#)

A test certificate that shows whether a welder possesses the necessary experience and knowledge to perform the specifications of a particular weld procedure. Documentation to be supplied in accordance with QW-301.4 ASME Section IX.

## Welding procedure specification (Q68)

[Back to Flanged ordering table](#)

A formal written document that describes and provides direction to a welder or welding operator for making sound and quality production welds per code requirements. Documentation to be supplied in accordance with Article V, ASME Section IX.

## Phased array ultrasonic test (Q80)

[Back to Flanged ordering table](#)

This test is only available on the full penetration weld flanged thermowells. Testing shall be performed in accordance with ASME section V article 4. Inspection criteria shall be per ASME Section VIII Div 1 per UW3 and conducted by a Level 2 Inspector. The certificate provided with this option will document the results and the inspectors acceptance criteria .

## X-ray/radiograph test (Q81)

[Back to Flanged ordering table](#)

Weld joints to be examined for any internal imperfections. Available only with full penetration flanged thermowells. test shall be performed according with ASME section V, article 24. Inspection criteria shall be per ASME section VIII, Div 1 per UW-51 by a level 2 inspector. Supplier to x-ray report for 10 years. Certificate shall include inspector, acceptance criteria and results. Marking made during test shall be removed.

## Spherical tip (R60)

[Back to Threaded ordering table](#)

[Back to Flanged ordering table](#)

[Back to Van Stone ordering table](#)

[Back to Welded ordering table](#)

Radius of spherical tip (B) is the same as the specified thermowell tip radius. Thermowell will still maintain specified "U" length.

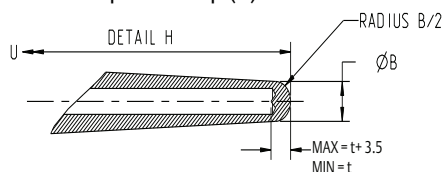



## Stainless steel plug and chain (R06)

[Back to Threaded ordering table](#)

[Back to Flanged ordering table](#)

[Back to Van Stone ordering table](#)

[Back to Welded ordering table](#)

The plug and chain are made from stainless steel. This plug is used to protect the thermowell threads when a sensor isn't installed. It also keeps elements such as rain, dust, and dirt out of the thermowell.



## Brass plug and chain (R23)

[Back to Threaded ordering table](#)

[Back to Flanged ordering table](#)

[Back to Van Stone ordering table](#)

[Back to Welded ordering table](#)

The plug and chain are made from brass. This plug is used to protect the thermowell threads when a sensor isn't installed. It also keeps elements such as rain, dust, and dirt out of the thermowell.



## Vent hole (R11)

[Back to Threaded ordering table](#)

[Back to Flanged ordering table](#)

[Back to Van Stone ordering table](#)

[Back to Welded ordering table](#)

The vent hole allows for the venting of a thermowell. Vent or weep holes are often used to prevent gas buildup in certain applications. This option is useful in applications where gas build up is a concern. Process fluid leakage from the vent hole is an indicator of thermowell failure.



## Flange face – concentric serrations (R09)

[Back to Flanged ordering table](#)

[Back to Van Stone ordering table](#)

This option changes the flange face so it has concentric serrations covering the wetted portion of the flange raised face. It is installed with an inside bolt circle (IBC) gasket/ring gasket, which extends to and is centered by the bolts. This flange face is designed per the ASME B16.5 standard.

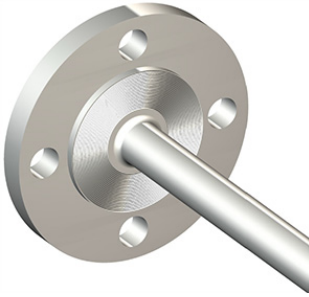

**Figure 25. Installation Components**

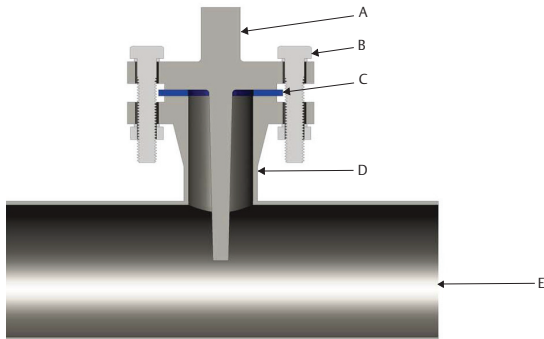

- A. Thermowell
- B. Bolt/washers
- C. Ring gasket
- D. Nozzle and mating flange
- E. Process

## Flange face – flat (R10)

[Back to Flanged ordering table](#)

This option changes the flange face so it has no raised section on the wetted portion of the flange face. The flat face is finished with spiral serrations. This style is frequently used where the mating flange is made from a casting or fragile material. It can be installed with ring gaskets or full face gaskets that extend past the bolt holes. This flange face is designed per the ASME B16.5 standard.

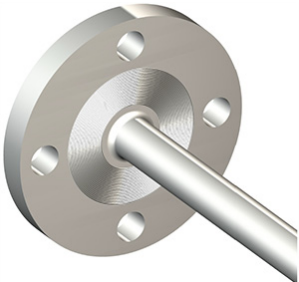

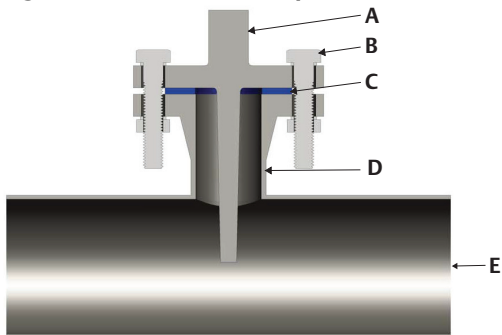
**Figure 26. Installation Components**

- A. Thermowell
- B. Bolt/washers
- C. Ring gasket
- D. Nozzle and mating flange
- E. Process

## Raised face – Type B2 (R15)

[Back to Flanged ordering table](#)

This option provides a smoother finish to the flange face compared to the standard Type B1 flange face.

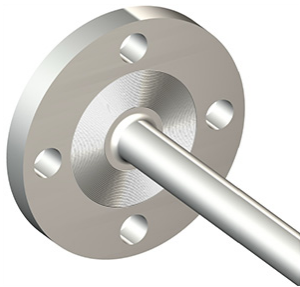
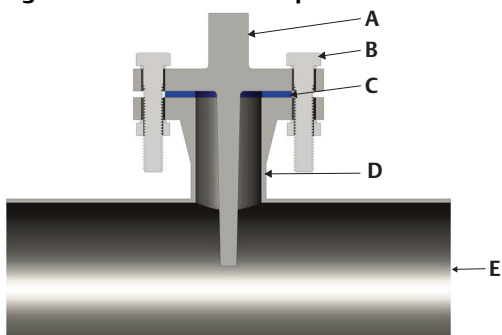
**Figure 27. Installation Components**

- A. Thermowell
- B. Bolt/washers
- C. Ring gasket
- D. Nozzle and mating flange
- E. Process

## Flange face – RTJ (R16)

[Back to Flanged ordering table](#)

[Back to Van Stone ordering table](#)

This option changes the flange face so it has a ring type joint (RTJ). The RTJ flange face is common for high pressure applications using Class 600 flanges or higher. Both mating flanges have grooves that can accept a RTJ gasket which is usually made of solid metal. This flange face is designed per the ASME B16.5 standard.

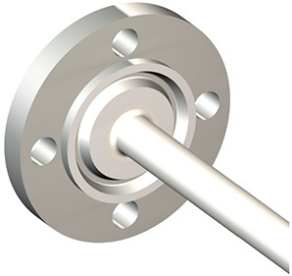

**Figure 28. Installation Components**

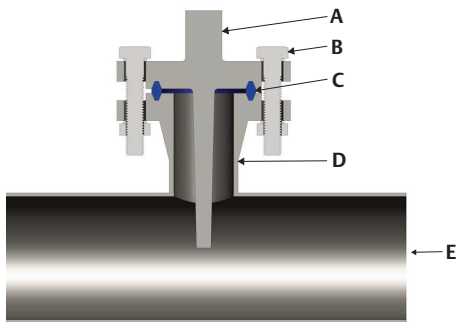

- A. Thermowell
- B. Bolt/washers
- C. Ring gasket
- D. Nozzle and mating flange
- E. Process

## Flange face – groove, Type D (R18)

[Back to Flanged ordering table](#)

[Back to Van Stone ordering table](#)

Type C “tongue” will mount to Type D “groove”.

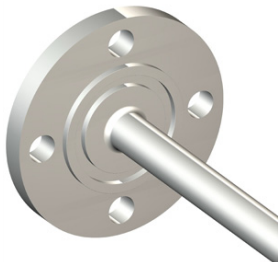

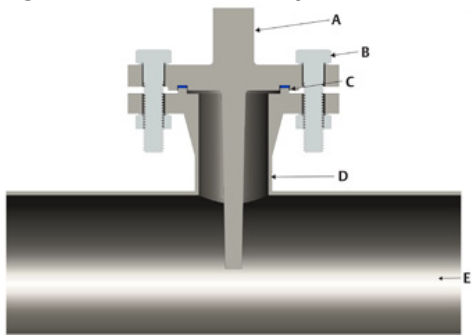
**Figure 29. Installation Components**

- A. Thermowell
- B. Bolt/washers
- C. Ring gasket
- D. Nozzle and mating flange
- E. Process

## Flange face – tongue, Type C (R19)

[Back to Flanged ordering table](#)

[Back to Van Stone ordering table](#)

Type C “tongue” will mount to Type D “groove”.

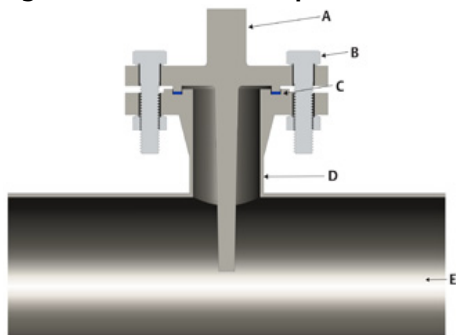
**Figure 30. Installation Components**

- A. Thermowell
- B. Bolt/washers
- C. Ring gasket
- D. Nozzle and mating flange
- E. Process

## Flange face – spigot, Type E (R24)

[Back to Flanged ordering table](#)

[Back to Van Stone ordering table](#)

Type E “spigot” will mount to type F “recess”.

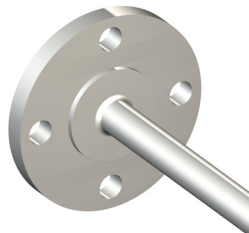

**Figure 31. Installation Components**

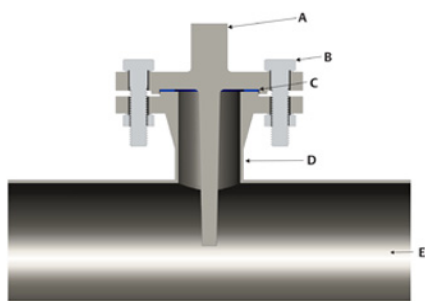

- A. Thermowell
- B. Bolt/washers
- C. Ring gasket
- D. Nozzle and mating flange
- E. Process

## Flange face – recess, Type F (R25)

[Back to Flanged ordering table](#)

[Back to Van Stone ordering table](#)

Type E “spigot” will mount to type F “recess”.

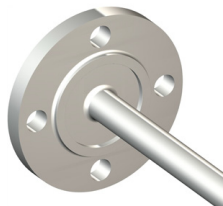

---

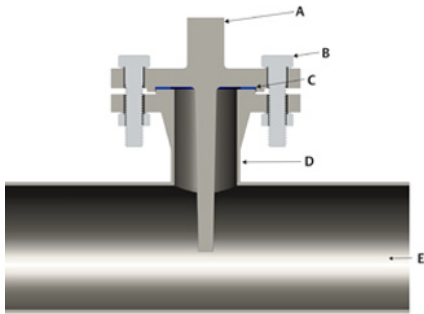
**Figure 32. Installation Components**

- A. Thermowell
  - B. Bolt/washers
  - C. Ring gasket
  - D. Nozzle and mating flange
  - E. Process
- 

## Thermowells with wrench flats (R37)

[Back to Threaded ordering table](#)

This option only applies to threaded thermowells made from exotic materials. By default, these thermowells are made with two wrench flats; this option must be selected to get hex (6) wrench flats.

---

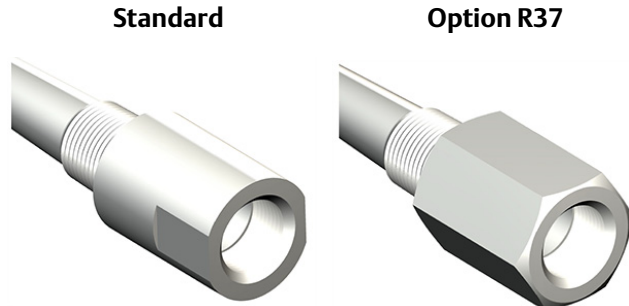
**Figure 33. Wrench Flats**

**Table 22. Exotic Materials**

Code	Material	Code	Material	Code	Material
AB	Alloy B3	AL	Alloy 600 with 304/304L SST flange)	CA	Chrome-Moly Grade B-11/F-11 Class II
AC	Alloy C-276	AU	Alloy C-22	CB	Chrome-Moly Grade B-22/ F-22 Class III
AD	Alloy C-4 (with 304/304L SST flange)	AM	Alloy 601	CC	Chrome-Moly Grade F-91
AE	Alloy C-22 (with 304/304L SST flange)	AN	Alloy 625	NK	Nickel 200
AF	Alloy C-22 (with 316/316L SST flange)	AP	Alloy 800	TT	Titanium Grade 2
AG	Alloy 20	AQ	Alloy800H/HT	DS	Super duplex SST Grade F-53
AH	Alloy 400	AR	Ally 825	DT	Super duplex SST Grade F-53 (NORSOK)
AJ	Alloy 400 (with 304/304L SST flange)	AS	Alloy F44 Mo6	DU	Duplex 2205 Grade F-51
AK	Alloy 600	MO	Molybdenum	DV	Duplex 2205 Grade F-51 (NORSOK)

## Root diameter (A0XX)

[Back to Threaded ordering table](#)

[Back to Flanged ordering table](#)

[Back to Van Stone ordering table](#)

[Back to Welded ordering table](#)

Larger root diameters will provide greater strength. Changing the root diameter is helpful when designing a thermowell to pass wake frequency calculations.

Guidelines on specifying design modifiers based on the stem profile are as follows:

- Straight – only root diameter (Axxx) should be specified
- Tapered – both root (Axxx) and tip diameter (Bxxx) must be specified
- Stepped – if root diameter (Axxx) only is specified, the tip will be standard 0.5-in diameter; if tip diameter (Bxxx) is ordered, root diameter (Axxx) must also be specified

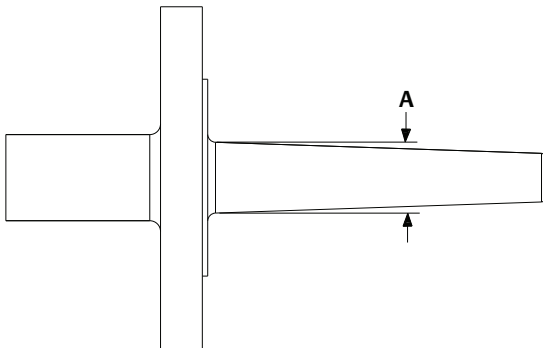



## Tip diameter (B0XX)

**Table 23. Sample Root Diameters**

Code	Dimension (E)	Code	Dimension (M)
A040	0.4-in.	A100	10 mm
A045	0.45-in.	A110	11 mm
A100	1.00-in.	A205	20.5 mm
A310	3.10-in.	A790	79 mm
A315	3.15-in.	A800	80 mm

[Back to Threaded ordering table](#)

[Back to Flanged ordering table](#)

[Back to Van Stone ordering table](#)

[Back to Welded ordering table](#)

Smaller tip diameters will improve time response. Changing the tip diameter is helpful when designing a thermowell to pass wake frequency calculations.

Guidelines on specifying design modifiers based on the stem profile are as follows:

- Straight – only root diameter (Axxx) should be specified
- Tapered – both root (Axxx) and tip diameter (Bxxx) must be specified
- Stepped – if root diameter (Axxx) only is specified, the tip will be standard 0.5-in. diameter; if tip diameter (Bxxx) is ordered, root diameter (Axxx) must also be specified

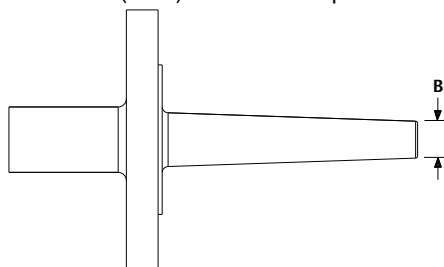

**Table 24. Sample Tip Diameters**

Code	Dimension (E)	Code	Dimension (M)
B040	0.4-in.	B120	12 mm
B045	0.45-in.	B130	13 mm
B100	1.00-in.	B205	20.5 mm
B175	1.75-in.	B450	45 mm
B180	1.80-in.	B460	46 mm

## Bore diameter (d0X)

[Back to Threaded ordering table](#)

[Back to Flanged ordering table](#)

[Back to Van Stone ordering table](#)

[Back to Welded ordering table](#)

Bore diameter (d) can be selected to accommodate different temperature sensor sizes. Time response is improved when the sensor and thermowells have a tighter fit.

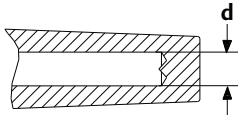

**Table 25. Available Bore Diameters**

Code	Dimension	Code	Dimension (M)
D01	0.276-in./7.0 mm	D05	0.354-in./9 mm
D03	0.138-in./3.5 mm	D06	0.433-in./11 mm
D04	0.385-in./9.8 mm		

## Tip thickness (t0X)

[Back to Threaded ordering table](#)

[Back to Flanged ordering table](#)

[Back to Van Stone ordering table](#)

[Back to Welded ordering table](#)

Tip thickness (t) is specified as the minimum thickness and measured from the top of the gun drill web as shown in the figure below

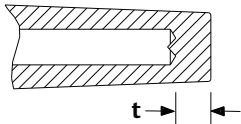

**Table 26. Available Tip Thicknesses**

Code	Dimension
T01	0.197-in./5.0 mm
T02	0.236-in./6.0 mm

## Van Stone stub thickness (FOX)

[Back to Van Stone ordering table](#)

Van Stone stub thickness is the thickness of the surface on which the flange lies as shown in the figure below.

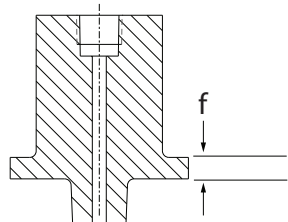

**Table 27. Available Stub Thicknesses**

Code	Dimension
F01	0.591-in. (15 mm)
F02	0.787-in. (20 mm)

## Fillet radius (EOX)

[Back to Flanged ordering table](#)

[Back to Van Stone ordering table](#)

Lap Joint flanges are machined with a flat face and a fillet radius to accommodate the stub end or pipe lap as shown in image below.

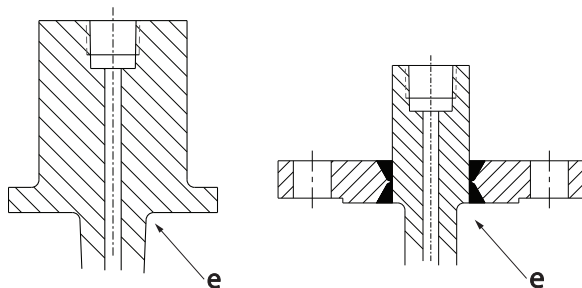

**Table 28. Available Fillet Radius**

Code	Dimension
E01	0.118-in. (3.0 mm)
E02	0.197-in. (5.0 mm)

## Lap flange material for Van Stone design (C0X)

[Back to Van Stone ordering table](#)

This option is only available when the Van Stone (V) mounting configuration is selected. By default, a Van Stone thermowell comes with a carbon steel A105 lap flange. These options give the choice of having the thermowell ordered without a flange, with a 316/316LSST flange, or with a flange of similar material as the thermowell stem. Below are some model string examples of the standard offering and options for reference:

Example model: 114CE0030VAA2SC032A – carbon steel A105 lap flange with 316/316L SST thermowell stem provided (standard)



Example model: 114CE0030VAA2SC032AC01 – no lap flange, only thermowell stem provided

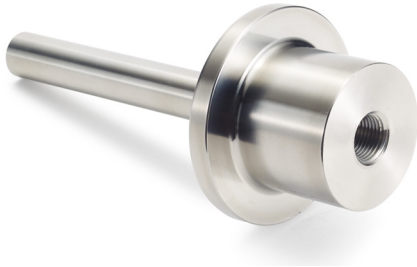

Example model: 114CE0030VAA2SC032AC02 – changes default carbon steel A105 lap cover flange to 316/316LSST flange



Example model: 114CE0030VAA2SC032AC03 – changes default cover flange to match thermowell stem material



---

**Note**

Coatings do not apply to lap flange.

---





## Global Headquarters

### Emerson Automation Solutions

6021 Innovation Blvd.  
Shakopee, MN 55379, USA  
 +1 800 999 9307 or +1 952 906 8888  
 +1 952 949 7001  
 RFQ.RMD-RCC@Emerson.com



## North America Regional Office

### Emerson Automation Solutions

8200 Market Blvd.  
Chanhassen, MN 55317, USA  
 +1 800 999 9307 or +1 952 906 8888  
 +1 952 949 7001  
 RMT-NA.RCCRFQ@Emerson.com



## Latin America Regional Office

### Emerson Automation Solutions

1300 Concord Terrace, Suite 400  
Sunrise, FL 33323, USA  
 +1 954 846 5030  
 +1 954 846 5121  
 RFQ.RMD-RCC@Emerson.com

## Europe Regional Office

### Emerson Automation Solutions Europe GmbH

Neuhofstrasse 19a P.O. Box 1046  
CH 6340 Baar  
Switzerland  
 +41 (0) 41 768 6111  
 +41 (0) 41 768 6300  
 RFQ.RMD-RCC@Emerson.com

## Asia Pacific Regional Office

### Emerson Automation Solutions

1 Pandan Crescent  
Singapore 128461  
 +65 6777 8211  
 +65 6777 0947  
 Enquiries@AP.Emerson.com

## Middle East and Africa Regional Office

### Emerson Automation Solutions

Emerson FZE P.O. Box 17033  
Jebel Ali Free Zone - South 2  
Dubai, United Arab Emirates  
 +971 4 8118100  
 +971 4 8865465  
 RFQ.RMTMEA@Emerson.com

 [Linkedin.com/company/Emerson-Automation-Solutions](https://www.linkedin.com/company/Emerson-Automation-Solutions)

 [Twitter.com/Rosemount\\_News](https://twitter.com/Rosemount_News)

 [Facebook.com/Rosemount](https://www.facebook.com/Rosemount)

 [Youtube.com/user/RosemountMeasurement](https://www.youtube.com/user/RosemountMeasurement)

 [Google.com/+RosemountMeasurement](https://www.google.com/+RosemountMeasurement)

Emerson Terms and Conditions of Sale are available upon request.  
The Emerson logo is a trademark and service mark of Emerson Electric Co.  
Rosemount is a mark of one of the Emerson family of companies.  
All other marks are the property of their respective owners.  
© 2019 Emerson. All rights reserved.