

Specifications

# SMART Board® interactive whiteboard

Model SBM680

## Overview

Your SMART Board® M680 interactive whiteboard features a durable interactive surface, two damage-resistant pens and SMART's proprietary DVIT® (Digital Vision Touch) technology. The SBM680 model supports dual touch, dual write and intuitive gestures, such as toss, rotate and zoom, available with multitouch operating systems, such as Windows® 7 or Mac Snow Leopard.

See [smarttech.com](http://smarttech.com) for more information on this product.

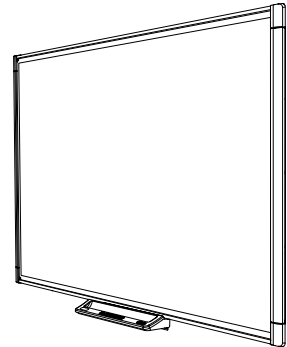

## Dimensions and weights<sup>1</sup>

### Dimensions

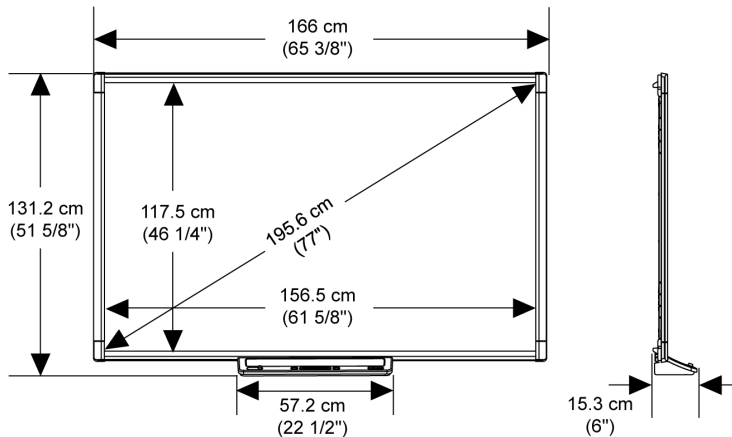

### Weight

18.5 kg (40 lb. 13 oz.)

### Shipping dimensions

181 cm W × 134.6 cm H × 11.4 cm D  
(71 1/4" × 53" × 4 1/2")

### Shipping weight

23.6 kg (52 lb.)

<sup>1</sup>All dimensions ± 1/8" (0.3 cm). All weights ± 2 lb. (0.9 kg).

## SPECIFICATIONS

SMART Board interactive whiteboard – Model SBM680

### Standard features

<b>Software</b>	You can install SMART Product Drivers and SMART Notebook™ collaborative learning software from the included DVD or from <a href="http://smarttech.com/downloads">smarttech.com/downloads</a> . Software upgrades are also available.
<b>Computer requirements</b>	A computer or laptop with a Windows operating system or Mac operating system software and SMART Notebook software installed. For a complete list of computer requirements, go to <a href="http://smarttech.com/downloads">smarttech.com/downloads</a> and browse to the latest SMART Notebook software release notes applicable to your operating system. <sup>2</sup>
<b>Touch and gestures</b>	Enables you to write, to erase and to perform mouse functions by touching the interactive whiteboard with your finger or a pen. This interactive whiteboard also features gesture capability, providing a natural and flexible way to interact with content.
<b>Multitouch capabilities</b>	Support for two simultaneous touches enables up to two users to interact with the interactive whiteboard by using the included pens or other objects, or by using their fingers to write and to perform gestures.
<b>SMART Ink™</b>	Smooths out the appearance of the digital ink, improving the legibility of your handwriting. The ink becomes an object you can move and manipulate.
<b>Pen tray</b>	The pen tray connects to the interactive whiteboard. Use the color select buttons to change digital ink colors. The on-screen keyboard, the right-click and the orient features are also accessible with pen tray buttons.
<b>Pen</b>	Includes two pens
<b>Screen surface</b>	The hard-coated steel surface is durable, is optimized for projection and is compatible with dry-erase markers.
<b>Digitizing technology</b>	Four-camera DVIT
<b>Frame finish</b>	White and light gray (approximates PANTONE® Cool Gray 4C)
<b>Power requirements</b>	1.8 m (6') power cable. Power consumption is less than 7 W (100V to 240V AC, 50/60 Hz, 5V DC 2.0A).
<b>Computer connection</b>	Includes a 5 m (16') USB 2.0 cable to connect to the room computer. Your SMART Board M680 interactive whiteboard supports one computer connection on a primary display only.

### Temperature specifications

<b>Storage</b>	-20°C to 50°C (-4°F to 122°F)
<b>Operation</b>	5°C to 35°C (41°F to 95°F) with up to 80% humidity, non-condensing

<sup>2</sup>A digital projector isn't included with this model of SMART Board interactive whiteboard. To take advantage of all interactive features, you must integrate a digital projector.

## Certification and compliance

**Regulatory certification** CSA (U.S./Canada)

---

### Environmental compliance

China	EIP
European Union	REACH, RoHS, WEEE, Packaging and ErP Standby
U.S.	Packaging and Conflict Minerals

## Purchasing information

### Order numbers

SBM680	195.6 cm (77") diagonal SMART Board M680 interactive whiteboard with an active pen tray. Includes a SMART Notebook software installation DVD.
--------	--

---

SBM680-B	Bulk order of 10 SBM680 units
----------	-------------------------------

---

**Optional accessories** See [smarttech.com/accessories](http://smarttech.com/accessories)

---

**Warranty** Two-year limited equipment warranty

---

[smarttech.com/support](http://smarttech.com/support)  
[smarttech.com/contactsupport](http://smarttech.com/contactsupport)

© 2013 SMART Technologies ULC. All rights reserved. SMART Board, DVIT, SMART Notebook, SMART Ink, smarttech, the SMART logo and all SMART taglines are trademarks or registered trademarks of SMART Technologies ULC in the U.S. and/or other countries. All third-party product and company names may be trademarks of their respective owners. This product and/or use thereof covered by one or more of the following U.S. patents. [www.smarttech.com/patents](http://www.smarttech.com/patents). Contents are subject to change without notice. 08/2013.