

RTECH-PHOTOMETRY LABORATORY

Testreport : Measurement of luminous intensity distribution related to the standard
NBN-EN 13032-1; NBN-EN 13032-4; CIE 121-1996; CIE S 025/E; IES LM-79-08 and procedures PT-P-01
and PT-P-02

rue de Mons, 3 B-4000 LIEGE - Tel : 04/224.71.40 - Fax : 04/224.25.90
Measurement for Schröder group.

LED

Origin TUNGSRAM-Schröder Zrt. Hungary	Production TUNGSRAM-Schröder Zrt. Hungary	Luminaire VOLTANA 0	Inclination 0°	Request # FD39022
Source				
Type LED	BIN 40-70M-4-TB-RB	Trademark Samsung	Reference LH351C	# LEDs 6
Reflector 5206	Master -			Reflector No 5206
DKI Led assembly Road lighting Injected 0.0°				
Protector Refractor Lens				
Protector integrated lenses				
Lens DKI 5206 PC				
Laboratory observation				
VOLTANA 0 with 6 Samsung LH 351C Used flux for efficiency matrix calculation = 1157lm - CCT = 3859K - CRI = 72,26 (see sphere test report 2019/52 on appendix).				
Purpose DOC		Sample date 08-01-2019	Sample # 39R004	
Observation				
DOC Voltana 0 with lenses 5206				
Flux coefficient multiplicator (only for efficiency matrix):				
From 350 to 500 mA : 1,379				
From 350 to 700 mA : 1,846				
From 350 to 1000mA: 2,450				
Notes				
The publication of this report in another form than the original one is not allowed without agreement of the laboratory. This report concerns type tests on one or a series of specimens.				

Asked by RCA	Measured by CLD	Approved by RLABO	Appendix 1	  226-TEST NBN EN ISO/IEC 17025 : 2005	42572
-----------------	--------------------	----------------------	---------------	---	--------------

LUMINOUS INTENSITY DIAGRAM

Origin TUNGSRAM-Schröder Zrt. Hungary		Production TUNGSRAM-Schröder Zrt. Hungary		Luminaire VOLTANA 0		Inclination 0°		Request # FD39022	
Source	Type LED	BIN 40-70M-4-TB-RB	Trademark Samsung	Reference LH351C	# LEDs 6	Reflector 5206			
Reflector	DKI Led assembly Road lighting Injected 0.0°				No	5206			
Matrices	425721		Φ 0-90° = 1040lm - 90-180° = 0lm			Absolute measurement			
Protector Refractor Lens	Protector integrated lenses Lens 6 x DKI 5206 PC								
Observation	<p>Matrix in total flux @350 mA</p> <p>Light losses due to thermal stabilisation : 1%</p> <p>Electrical measurement on LED (#1) : Voltage = 16.83 V Current = 0.350 A Power = 5.88 W</p> <p>Electrical measurement on driver (#1) : Voltage = 230.00 V Current = 0.037 A Power = 7.98 W PF = 0.936</p> <p>Total luminaire power = 7.98 W : Lm/Watt = 130.30 lm/W</p> <p>Driver #1 : Philips Xitanium FP 22W 0.3-1.0A SNLDAE 230V S175 sXt S175 sxt PCB 00-71-626 A</p>								

Plane	I Peak	Peak position	Index	I zero	Laboratory ambient t°	Measurement date	↕
15 - 165	723	55	S	369	24.9°	07-02-2019	
90	384	7	D				
270	369	0	G				

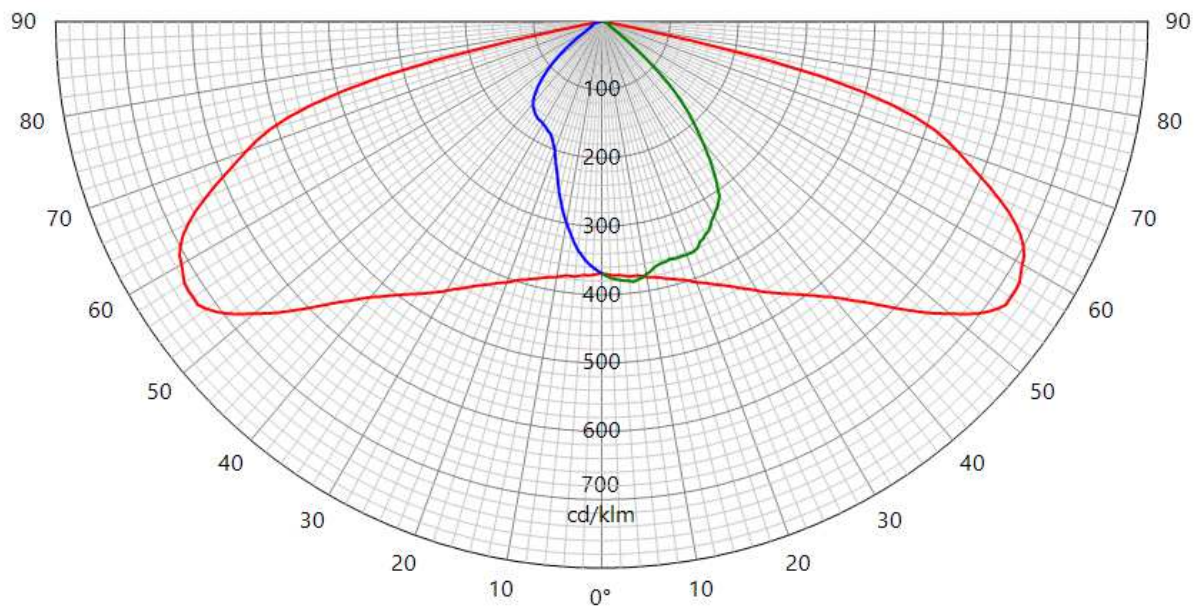

42572

LUMINOUS INTENSITY DIAGRAM

Origin TUNGSRAM-Schröder Zrt. Hungary		Production TUNGSRAM-Schröder Zrt. Hungary		Luminaire VOLTANA 0		Inclination 0°		Request # FD39022	
Source	Type LED	BIN 40-70M-4-TB-RB	Trademark Samsung	Reference LH351C	# LEDs 6	Reflector 5206			
Reflector	DKI Led assembly Road lighting Injected 0.0°				No	5206			
Matrices	425722		η 0-90° = 89.9% - 90-180° = 0.0%			Relative measurement			
Protector Refractor Lens	Protector integrated lenses Lens 6 x DKI 5206 PC								
Observation	<p>Matrix in efficiency @350 mA</p> <p>Light losses due to thermal stabilisation : 1%</p> <p>Electrical measurement on LED (#1) : Voltage = 16.83 V Current = 0.350 A Power = 5.88 W</p> <p>Electrical measurement on driver (#1) : Voltage = 230.00 V Current = 0.037 A Power = 7.98 W PF = 0.936</p> <p>Total luminaire power = 7.98 W</p> <p>Driver #1 : Philips Xitanium FP 22W 0.3-1.0A SNLDAE 230V S175 sXt S175 sxt PCB 00-71-626 A</p>								

Plane	I Peak	Peak position	Index	I zero	Laboratory ambient t°	Measurement date	↕
15 - 165	625	55	S	319	24.9°	07-02-2019	
90	332	7	D				
270	319	0	G				

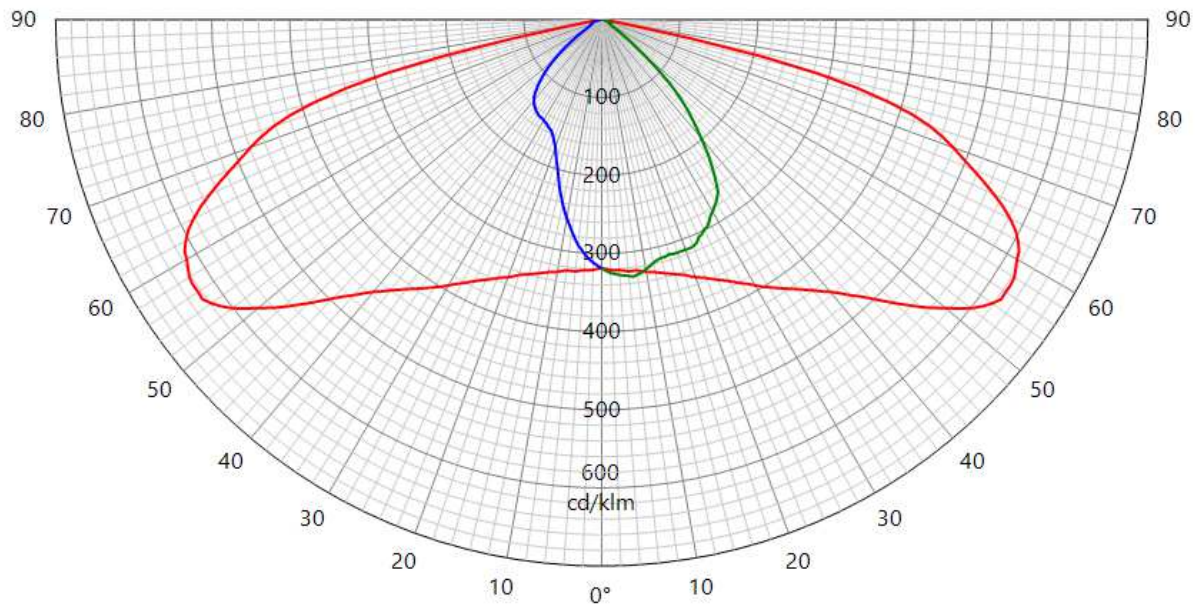

42572

LUMINOUS INTENSITY DIAGRAM

Origin TUNGSRAM-Schröder Zrt. Hungary		Production TUNGSRAM-Schröder Zrt. Hungary		Luminaire VOLTANA 0		Inclination 0°		Request # FD39022	
Source	Type LED	BIN 40-70M-4-TB-RB	Trademark Samsung	Reference LH351C	# LEDs 6	Reflector 5206			
Reflector	DKI Led assembly Road lighting Injected 0.0°				No	5206			
Matrices	425723		Φ 0-90° = 1434lm - 90-180° = 0lm			Absolute measurement			
Protector Refractor Lens	Protector integrated lenses Lens 6 x DKI 5206 PC								
Observation	<p>Matrix in total flux @500 mA</p> <p>Light losses due to thermal stabilisation : 1.7%</p> <p>Electrical measurement on LED (#1) : Voltage = 17.15 V Current = 0.500 A Power = 8.58 W</p> <p>Electrical measurement on driver (#1) : Voltage = 230.00 V Current = 0.050 A Power = 10.97 W PF = 0.962</p> <p>Total luminaire power = 10.97 W : Lm/Watt = 130.70 lm/W</p> <p>Driver #1 : Philips Xitanium FP 22W 0.3-1.0A SNLDAE 230V S175 sXt S175 sxt PCB 00-71-626 A</p>								

Plane	I Peak	Peak position	Index	I zero	Laboratory ambient t°	Measurement date	↕
15 - 165	998	57	S	511	24.9°	07-02-2019	
90	532	7	D				
270	511	0	G				

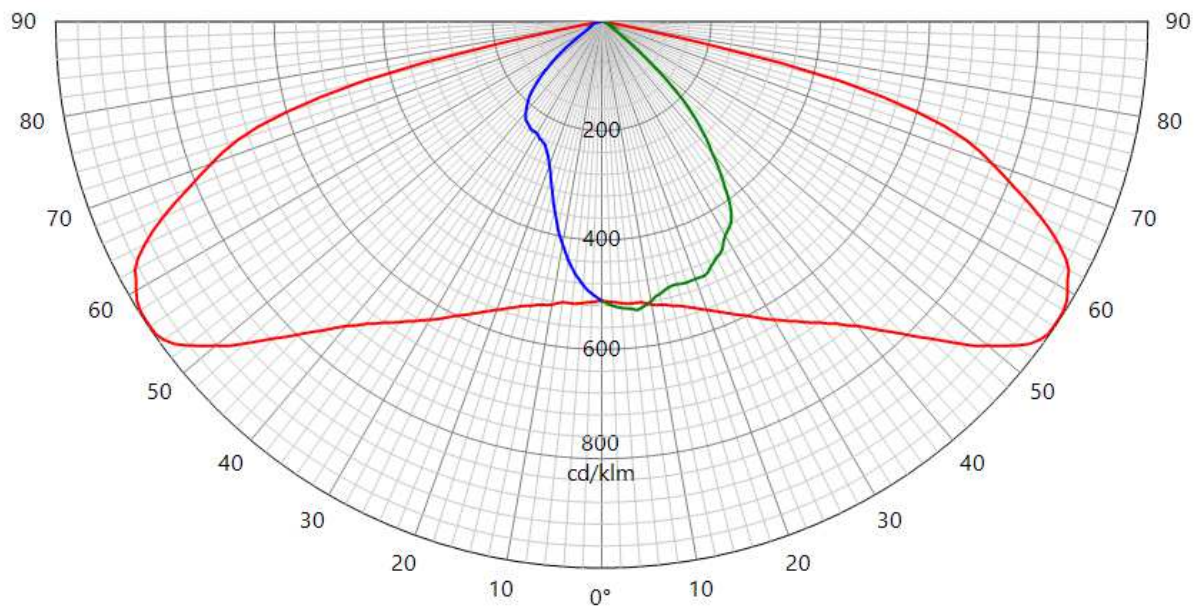

42572

LUMINOUS INTENSITY DIAGRAM

Origin TUNGSRAM-Schröder Zrt. Hungary		Production TUNGSRAM-Schröder Zrt. Hungary		Luminaire VOLTANA 0		Inclination 0°		Request # FD39022	
Source	Type LED	BIN 40-70M-4-TB-RB	Trademark Samsung	Reference LH351C	# LEDs 6	Reflector 5206			
Reflector	DKI Led assembly Road lighting Injected 0.0°				No	5206			
Matrices	425724		Φ 0-90° = 1919lm - 90-180° = 0lm			Absolute measurement			
Protector Refractor Lens	Protector integrated lenses Lens 6 x DKI 5206 PC								
Observation	<p>Matrix in total flux @700 mA</p> <p>Light losses due to thermal stabilisation : 2,6 %</p> <p>Electrical measurement on LED (#1) : Voltage = 17.51 V Current = 0.700 A Power = 12.27 W</p> <p>Electrical measurement on driver (#1) : Voltage = 230.00 V Current = 0.067 A Power = 15.15 W PF = 0.977</p> <p>Total luminaire power = 15.15 W : Lm/Watt = 126.68 lm/W</p> <p>Driver #1 : Philips Xitanium FP 22W 0.3-1.0A SNLDAE 230V S175 sXt S175 sxt PCB 00-71-626 A</p>								

Plane	I Peak	Peak position	Index	I zero	Laboratory ambient t°	Measurement date	↕
15 - 165	1342	57	S	686	24.9°	07-02-2019	
90	713	6	D				
270	686	0	G				

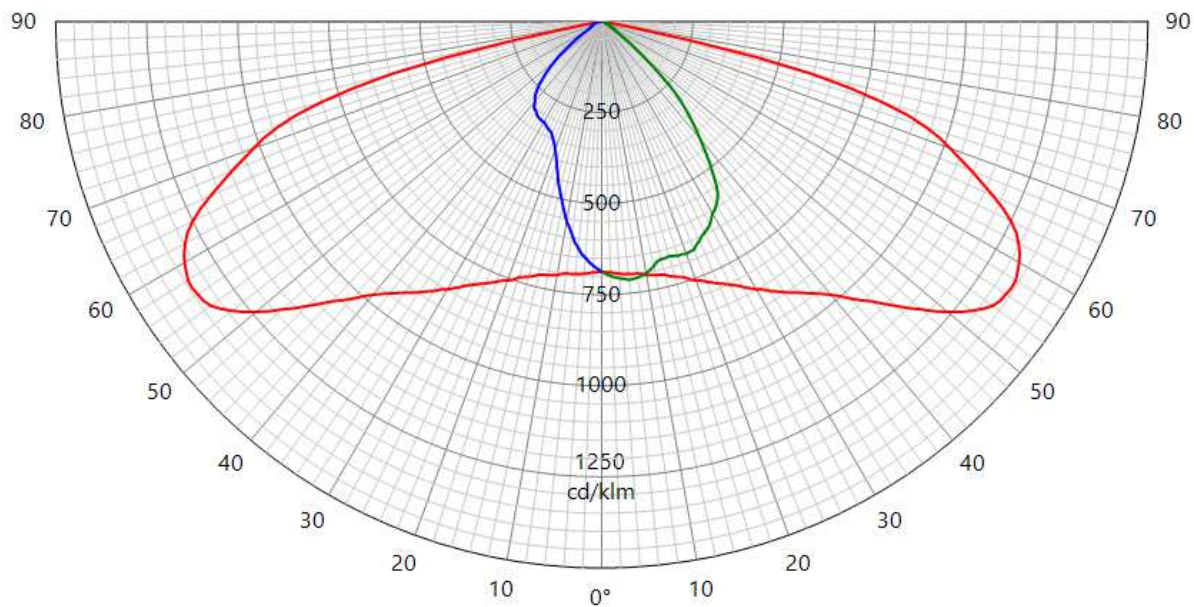

42572

LUMINOUS INTENSITY DIAGRAM

Origin TUNGSRAM-Schröder Zrt. Hungary		Production TUNGSRAM-Schröder Zrt. Hungary		Luminaire VOLTANA 0		Inclination 0°		Request # FD39022	
Source	Type LED	BIN 40-70M-4-TB-RB	Trademark Samsung	Reference LH351C	# LEDs 6	Reflector 5206			
Reflector	DKI Led assembly Road lighting Injected 0.0°				No	5206			
Matrices	425725		Φ 0-90° = 2548lm - 90-180° = 0lm			Absolute measurement			
Protector Refractor Lens	Protector integrated lenses Lens 6 x DKI 5206 PC								
Observation	<p>Matrix in total flux @1000 mA</p> <p>Light losses due to thermal stabilisation : 3,7 %</p> <p>Electrical measurement on LED (#1) : Voltage = 17.96 V Current = 1.000 A Power = 17.96 W</p> <p>Electrical measurement on driver (#1) : Voltage = 230.00 V Current = 0.096 A Power = 21.80 W PF = 0.987</p> <p>Total luminaire power = 21.80 W : Lm/Watt = 116.87 lm/W</p> <p>Driver #1 : Philips Xitanium FP 22W 0.3-1.0A SNLDAE 230V S175 sXt S175 sxt PCB 00-71-626 A</p>								

Plane	I Peak	Peak position	Index	I zero	Laboratory ambient t°	Measurement date	↕
15 - 165	1783	56	S	914	24.9°	07-02-2019	
90	952	7	D				
270	914	0	G				

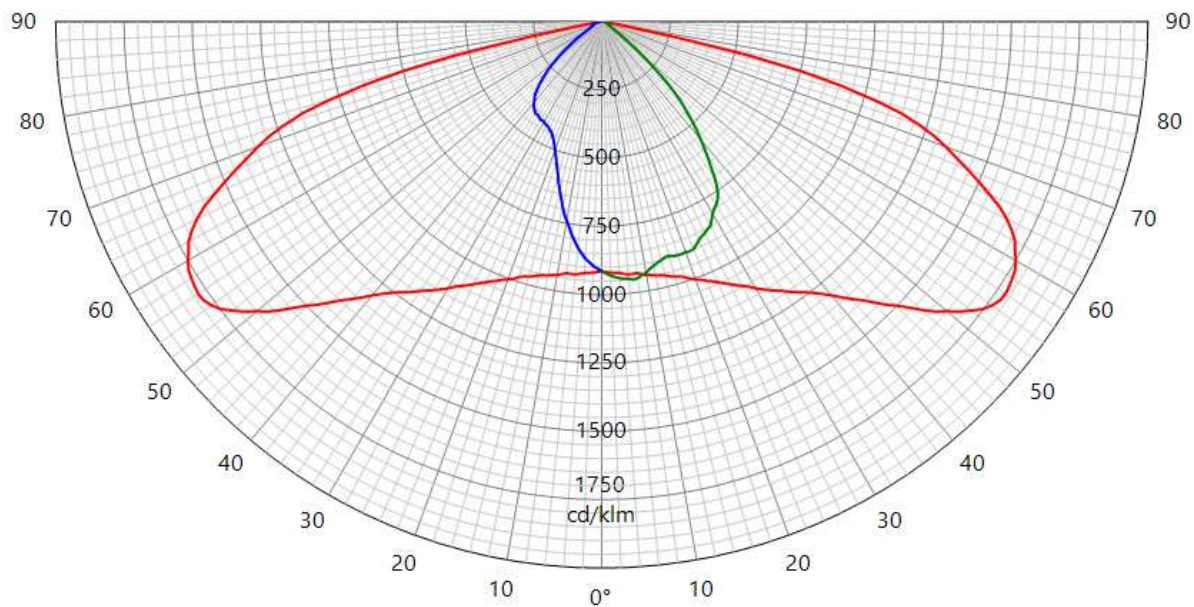

42572

CONFORMITY STATEMENT

Measurement fulfil Standards:

NBN-EN 13032-1
NBN-EN 13032-4
NBN-EN 17025:2005
CIE 121-1996
LM79-08
CIE S 025

Measurement quantities measured:

Light distribution in relative or absolute photometry
Led alone cold lumen package
Led CCT and CRI
Power consumption of the fitting
Lm/watt

Electrical measurement, if not specified:

Primary values are AC with 50Hz frequency
Secondary values on SSL are DC

CCT, CRI and chromaticity coordinates: are measured in Ulbricht sphere.
If specified Main test report refer to sphere extra test report.

Light distribution are measured on gonio. If not otherwise specified, measurement is done at 50 Hz

Number of hours operated prior to measurement: if not otherwise specified, 0 hours (no aging).

Stabilization time: If not otherwise specified, a minimal stabilization time of 0.5 hour is applied; and measurement will start when it exists no more variation above 0.5% in 15 minutes

Total operating time of the product including stabilization:
45 minutes have to be added by measurement.
Minimal operating time is 75 minutes

Luminous intensity distribution: available on electronic file with
.mat format (internal Schröder format)
.ldt format (European standard)
.IES format (American standard)

Statement of uncertainties (K=2, 95% of confidence level):
Uncertainties calculated based on a typical Schröder fitting and PCBA

Intensity measurement: +/- 3%
Angle: +/- 0.5°
Flux: +/- 2.5%
Electrical DC
Power: +/- 0.25%
Voltage: +/- 0.15%
Current: +/- 0.15%
Electrical AC
Power: +/- 0.15%
Voltage: +/- 0.3%
Current: +/- 0.3%
Temperature: +/- 0.65%

ISP2000	JETI	
CCT:	+/- 5%	+/-7.5%
CRI:	+/- 2%	+/-2.75%
x/y:	+/- 2%	+/-4.6%

lm/Watt: +/-3.5%

Measuring instruments in use:

Gonio 1

Type C with Moving mirror

Manufacturer: LMT Lichtmesstechnik GmbH Berlin, Helmholtzstrasse 9 10587 Berlin, Germany

Type: GO-DS 2000

Calibration: traceable to PTB (Physikalisch-Technische Bundesanstalt D-Braunschweig) and METAS (Federal Institute of Metrology, CH-Bern)

Photometric test distance: By default 10 meter, on request 30 meter.

Gonio 2

Type C

Manufacturer: Technoteam Bildverarbeitung, Werner-von-Siemens-Strasse 5 98693 Ilmenau, Germany

Calibration: traceable to BIPM (Bureau International des Poids et Mesures F-Sèvres)

Photometric test distance: Near Field

Sphere n°1

4p geometry

Manufacturer: LMT Lichtmesstechnik GmbH, Helmholtzstrasse 9 10587 Berlin, Germany

Type: UL2000 + U1000 V-Lambda photometer

Calibration: traceable to BIPM (Bureau International des Poids et Mesures F-Sèvres)

Sphere n°2

4p geometry

Manufacturer: Instrument Systems GmbH, Neumarkter Str. 83, 81673 Muenchen, Germany

Type ISP2000 + Spectroradiometer CAS120 and CAS140

Calibration: traceable to NIST

Colorimetric portable spectroradiometer

Manufacturer: JETI Technische Instrumente GmbH, Tatzendpromenade 2 07745 Jena

Type: SPECBOS 1201

Calibration: traceable to NIST

Multimeters

Manufacturer: Agilent

Type: 34401A

Calibration: traceable to BIPM (Bureau International des Poids et Mesures F-Sèvres)

Wattmeters

Manufacturer: Yokogawa

Type: WT210 and WT310

Calibration: traceable to BIPM (Bureau International des Poids et Mesures F-Sèvres)

Thermometers

Amarell Precision

Type: Liquid in glass N63833

Calibration: traceable to LBT (Laboratoire Belge de Thermométrie)



Test Report issued under the responsibility of:



TEST REPORT
IEC 60598-2-3
Luminaires
Part 2: Particular requirements
Section 3: Luminaires for road and street lighting

Report Number : P1560-1a
 Date of issue : 2017-03-03
 Total number of pages : 45+2

Name of Testing Laboratory preparing the Report : R-TECH

Applicant's name : R-TECH
 Address : Rue de Mons, 3,B-4000 LIEGE

Test specification:

Standard : IEC 60598-2-3:2002 (Third Edition) + A1:2011 used in conjunction with IEC 60598-1:2014 (Eighth Edition)
 Test procedure : CB Scheme
 Non-standard test method : N/A

Test Report Form No. : IEC60598_2_3J
 Test Report Form(s) Originator : Intertek Semko AB
 Master TRF : 2014-09

Copyright © 2014 IEC System of Conformity Assessment Schemes for Electrotechnical Equipment and Components (IECEE System). All rights reserved.

This publication may be reproduced in whole or in part for non-commercial purposes as long as the IECEE is acknowledged as copyright owner and source of the material. IECEE takes no responsibility for and will not assume liability for damages resulting from the reader's interpretation of the reproduced material due to its placement and context.



If this Test Report Form is used by non-IECEE members, the IECEE/IEC logo and the reference to the CB Scheme procedure shall be removed.

This report is not valid as a CB Test Report unless signed by an approved CB Testing Laboratory and appended to a CB Test Certificate issued by an NCB in accordance with IECEE 02.

General disclaimer:

The test results presented in this report relate only to the object tested.
This report shall not be reproduced, except in full, without the written approval of the Issuing CB Testing Laboratory. The authenticity of this Test Report and its contents can be verified by contacting the NCB, responsible for this Test Report.

Test item description	Street lighting
Trade Mark	SCHREDER
Manufacturer	SCHREDER
Model/Type reference	VOLTANA 0
Ratings	120-240 V, 50-60 Hz, Cl. I , IP66, LED, IK08 (glass), IK08 (lenses). Version with 6 & 8 led's ; Max. 23 & max.31 W. Led: Max 1050 mA

Responsible Testing Laboratory (as applicable), testing procedure and testing location(s):		
<input type="checkbox"/>	CB Testing Laboratory:	
Testing location/ address		
<input type="checkbox"/>	Associated CB Testing Laboratory:	
Testing location/ address		
Tested by (name, function, signature)		
Approved by (name, function, signature)...		
<input type="checkbox"/>	Testing procedure: TMP/CTF Stage 1:	
Testing location/ address		
Tested by (name, function, signature)		
Approved by (name, function, signature)...		
<input type="checkbox"/>	Testing procedure: WMT/CTF Stage 2:	
Testing location/ address		
Tested by (name + signature)		
Witnessed by (name, function, signature) . :		
Approved by (name, function, signature)...		
<input checked="" type="checkbox"/>	Testing procedure: SMT/CTF Stage 3 or 4:	R-Tech
Testing location/ address		Rue de Mons, 3,B-4000 LIEGE
Tested by (name, function, signature)		Laurent Maghe 
Witnessed by (name, function, signature) . :		Christian Maes 
Approved by (name, function, signature)...		Cheuvart Geoffrey 
Supervised by (name, function, signature) :		

<p>List of Attachments (including a total number of pages in each attachment):</p> <p>EU deviations</p> <p>Picture s</p> <p>Instructions</p>	
<p>Summary of testing: full test</p>	
<p>Tests performed (name of test and test clause):</p> <p>IEC 60598-2-3:2002 (Third Edition) + A1:2011 used in conjunction with IEC 60598-1:2014 (Eighth Edition)</p>	<p>Testing location:</p> <p>R-tech sa Rue de Mons, 3 B-4000 LIEGE Belgium.</p>
<p>Summary of compliance with National Differences: Europe</p> <p>List of countries addressed</p> <p><input checked="" type="checkbox"/> The product fulfils the requirements of</p> <p>IEC 60598-2-3: 2002 (third Edition) + A1:2011 used in conjunction with IEC 60598-1: 2014 (Eighth Edition). EN 60598-2-3: 2003 + A1:2011 used in conjunction with EN 60598-1:2014.</p>	

Copy of marking plate:

The artwork below may be only a draft. The use of certification marks on a product must be authorized by the respective NCBS that own these marks.

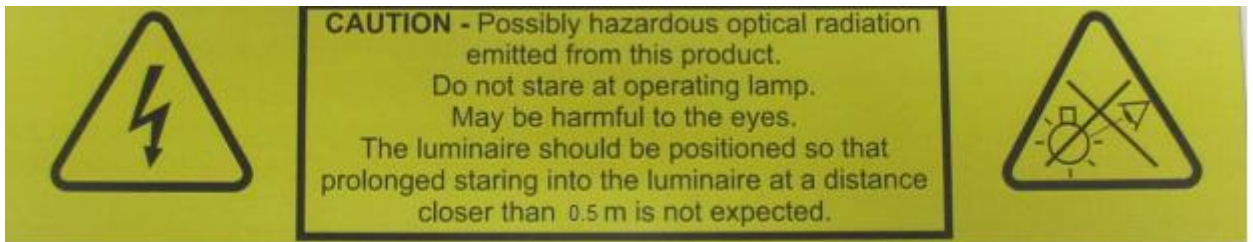

Test item particulars :	
Classification of installation and use : Class I	
Supply Connection : Connector	
..... :	
Possible test case verdicts:	
- test case does not apply to the test object..... : N/A	
- test object does meet the requirement..... : P (Pass)	
- test object does not meet the requirement..... : F (Fail)	
Testing	
Date of receipt of test item : October 2016	
Date (s) of performance of tests : February 2017	
.....	
General remarks:	
"(See Enclosure #)" refers to additional information appended to the report. "(See appended table)" refers to a table appended to the report.	
Throughout this report a <input type="checkbox"/> comma / <input type="checkbox"/> point is used as the decimal separator.	
Manufacturer's Declaration per sub-clause 4.2.5 of IEC60598-2:	
The application for obtaining a CB Test Certificate includes more than one factory location and a declaration from the Manufacturer stating that the sample(s) submitted for evaluation is (are) representative of the products from each factory has been provided..... :	<input checked="" type="checkbox"/> Yes <input type="checkbox"/> Not applicable
When differences exist; they shall be identified in the General product information section.	
Name and address of factory (ie s) :	
Comatelec S.A. Z.I. F-18400 SAINT FLORENT S/CHER France	Socelec S.A. Av. de Roanne, 66 Poligono Industrial "EL HENARES" 19180 MARCHAMALO (GUADALAJARA),Spain
Schröder Iluminação S.A. Apartado, 132 2790-076 CARNAXIDE,Portugal	Schröder do Brasil Iluminação Ltda. Rua Iracema Lucas, 415 Distrito Industrial Vinhedo 13280-000 SAO PAULO,Brazil
Schreder TOV Vul. Mykulynetska 46B 46000 TERNOPIIL,Ukraine	Schreder (China) Lighting Industrial Co., Ltd No.40 Xinye 2 Street, Tianjin Economic Technological Development Zone West Zone, 300462 Tianjin City, P.R.China,China
Tungsram-Schröder Világítási Berendezések Zrt Tópart 2 2084 PILISSZENTIVAN,Hungary	

General product information :

Ta following Leds current :

LED Count	Current (mA)	Power (W)	Ta (°C)	Ta with EMI filter(°C)
6	350	8	50	35
	500	10	50	30
	700	15	50	30
	1050	23	35	20
8	350	11	40	/
	500	14	40	/
	700	20	40	/
	1050	31	30	/

Color Temperature can be :

NW neutral white

CW cool white

WW warm white

IEC 60598-2-3			
Clause	Requirement + Test	Result - Remark	Verdict

3.2 (0)	GENERAL TEST REQUIREMENTS		P
3.2 (0.1)	Information for luminaire design considered	Standard Yes <input checked="" type="checkbox"/> No <input type="checkbox"/>	—
3.2 (0.3)	More sections applicable	Yes <input type="checkbox"/> No <input checked="" type="checkbox"/>	—

3.4 (2)	CLASSIFICATION		P
3.4 (2.2)	Type of protection	Class I	—
3.4 (2.3)	Degree of protection	IP 66	—
3.4 (2.4)	Luminaire suitable for direct mounting on normally flammable surfaces	Yes <input checked="" type="checkbox"/> No <input type="checkbox"/>	—
3.4 (2.5)	Luminaire for normal use	Yes <input checked="" type="checkbox"/> No <input type="checkbox"/>	—
	Luminaire for rough service	Yes <input type="checkbox"/> No <input checked="" type="checkbox"/>	—
3.4 (-)	Modes of installation of road or street lighting		—
	a) on a pipe	Yes <input checked="" type="checkbox"/> No <input type="checkbox"/>	—
	b) on a mast arm	Yes <input checked="" type="checkbox"/> No <input type="checkbox"/>	—
	c) on a post top	Yes <input checked="" type="checkbox"/> No <input type="checkbox"/>	—
	d) on span or suspension wires	Yes <input type="checkbox"/> No <input checked="" type="checkbox"/>	—
	e) on a wall	Yes <input type="checkbox"/> No <input checked="" type="checkbox"/>	—

3.5 (3)	MARKING		
3.5 (3.2)	Mandatory markings		P
	Position of the marking		P
	Format of symbols/text		P
3.5 (3.3)	Additional information		P
	Language of instructions		P
3.5 (3.3.1)	Combination luminaires		N/A
3.5 (3.3.2)	Nominal frequency in Hz	50-60 Hz	P
3.5 (3.3.3)	Operating temperature		N/A
3.5 (3.3.4)	Symbol or warning notice		N/A
3.5 (3.3.5)	Wiring diagram		N/A
3.5 (3.3.6)	Special conditions		N/A
3.5 (3.3.7)	Metal halide lamp luminaire – warning		N/A
3.5 (3.3.8)	Limitation for semi-luminaires		N/A
3.5 (3.3.9)	Power factor and supply current	0.91	P

IEC 60598-2-3			
Clause	Requirement + Test	Result - Remark	Verdict
3.5 (3.3.10)	Suitability for use indoors		N/A
3.5 (3.3.11)	Luminaires with remote control		N/A
3.5 (3.3.12)	Clip-mounted luminaire – warning		N/A
3.5 (3.3.13)	Specifications of protective shields		N/A
3.5 (3.3.14)	Symbol for nature of supply		N/A
3.5 (3.3.15)	Rated current of socket outlet		N/A
3.5 (3.3.16)	Rough service luminaire		N/A
3.5 (3.3.17)	Mounting instruction for type Y, type Z and some type X attachments		P
3.5 (3.3.18)	Non-ordinary luminaires with PVC cable		N/A
3.5 (3.3.19)	Protective conductor current in instruction if applicable		N/A
3.5 (3.3.20)	Provided with information if not intended to be mounted within arm's reach		N/A
3.5 (3.3.21)	Non-replaceable and non-user replaceable light sources information provided		P
	Cautionary symbol		P
3.5 (3.3.22)	Controllable luminaires, classification of insulation provided		N/A
3.5 (3.4)	Test with water		P
	Test with hexane		P
	Legible after test		P
	Label attached		P
3.5 (-)	Additional information in instruction leaflet		
	a) Design attitude	See attached Installation Notice	P
	b) Weight	See attached Installation Notice	P
	c) Overall dimensions	See attached Installation Notice	P
	d) Maximum projected area if applicable	See attached Installation Notice	P
	e) Cross-sectional area of wires if applicable		N/A
	f) Suitability for indoors use		N/A
	g) Dimensions of the compartment		N/A
	h) Torque setting to be applied to bolts or screws	See attached Installation Notice	P
	i) Maximum mounting height	>6 m	P

IEC 60598-2-3			
Clause	Requirement + Test	Result - Remark	Verdict
3.6 (4)	CONSTRUCTION		
3.6 (4.2)	Components replaceable without difficulty		N/A
3.6 (4.3)	Wireways smooth and free from sharp edges		P
3.6 (4.4)	Lampholders		
3.6 (4.4.1)	Integral lampholder		N/A
3.6 (4.4.2)	Wiring connection		N/A
3.6 (4.4.3)	Lampholder for end-to-end mounting		N/A
3.6 (4.4.4)	Positioning		N/A
	- pressure test (N)		—
	After test the lampholder comply with relevant standard sheets and show no damage		N/A
	After test on single-capped lampholder the lampholder have not moved from its position and show no permanent deformation		N/A
	- bending test (N)		—
	After test the lampholder have not moved from its position and show no permanent deformation		N/A
3.6 (4.4.5)	Peak pulse voltage		N/A
3.6 (4.4.6)	Centre contact		N/A
3.6 (4.4.7)	Parts in rough service luminaires resistant to tracking		N/A
3.6 (4.4.8)	Lamp connectors		N/A
3.6 (4.4.9)	Caps and bases correctly used		N/A
3.6 (4.4.10)	Light source for lampholder or connection according IEC 60061 not connected another way		N/A
3.6 (4.5)	Starter holders		
	Starter holder in luminaires other than class II		N/A
	Starter holder class II construction		N/A
3.6 (4.6)	Terminal blocks		
	Tails	Provided with internal connector	N/A
	Unsecured blocks	Fixed	N/A
3.6 (4.7)	Terminals and supply connections		
3.6 (4.7.1)	Contact to metal parts		P
3.6 (4.7.2)	Test 8 mm live conductor		P
	Test 8 mm earth conductor		P
3.6 (4.7.3)	Terminals for supply conductors		P

IEC 60598-2-3			
Clause	Requirement + Test	Result - Remark	Verdict
3.6 (4.7.3.1)	Welded method and material		
	- stranded or solid conductor		N/A
	- spot welding		N/A
	- welding between wires		N/A
	- Type Z attachment		N/A
	- mechanical test according to 15.8.2		N/A
	- electrical test according to 15.9		N/A
	- heat test according to 15.9.2.3 and 15.9.2.4		N/A
3.6 (4.7.4)	Terminals other than supply connection		N/A
3.6 (4.7.5)	Heat-resistant wiring/sleeves		N/A
3.6 (4.7.6)	Multi-pole plug		N/A
	- test at 30 N		N/A
3.6 (4.8)	Switches		
	- adequate rating		N/A
	- adequate fixing		N/A
	- polarized supply		N/A
	- compliance with IEC 61058-1 for electronic switches		N/A
3.6 (4.9)	Insulating lining and sleeves		
3.6 (4.9.1)	Retainment		N/A
	Method of fixing		—
3.6 (4.9.2)	Insulated linings and sleeves:		
	Resistant to a temperature > 20 °C to the wire temperature or		N/A
	a) & c) Insulation resistance and electric strength		N/A
	b) Ageing test. Temperature (°C)		N/A
3.6 (4.10)	Double or reinforced insulation		
3.6 (4.10.1)	No contact, mounting surface – accessible metal parts – wiring of basic insulation		N/A
	Safe installation fixed luminaires		N/A
	Capacitors and switches		N/A
	Interference suppression capacitors according to IEC 60384-14		N/A
3.6 (4.10.2)	Assembly gaps:		
	- not coincidental		N/A

IEC 60598-2-3			
Clause	Requirement + Test	Result - Remark	Verdict
	- no straight access with test probe		N/A
3.6 (4.10.3)	Retention of insulation:		
	- fixed		N/A
	- unable to be replaced; luminaire inoperative		N/A
	- sleeves retained in position		N/A
	- lining in lampholder		N/A
3.6 (4.11)	Electrical connections and current-carrying parts		
3.6 (4.11.1)	Contact pressure		P
3.6 (4.11.2)	Screws:		
	- self-tapping screws		N/A
	- thread-cutting screws		N/A
3.6 (4.11.3)	Screw locking:		
	- spring washer		P
	- rivets		N/A
3.6 (4.11.4)	Material of current-carrying parts		P
3.6 (4.11.5)	No contact to wood or mounting surface		P
3.6 (4.11.6)	Electro-mechanical contact systems		N/A
3.6 (4.12)	Screws and connections (mechanical) and glands		
3.6 (4.12.1)	Screws not made of soft metal		P
	Screws of insulating material		N/A
	Torque test: torque (Nm); part : 2Nm (case)		P
	Torque test: torque (Nm); part : 1.2Nm (drivers)		N/A
	Torque test: torque (Nm); part : 1.2Nm (glass)		N/A
3.6 (4.12.2)	Screws with diameter < 3 mm screwed into metal		N/A
3.6 (4.12.4)	Locked connections:		
	- fixed arms; torque (Nm) :		P
	- lampholder; torque (Nm) :		N/A
	- push-button switches; torque 0,8 Nm :		N/A
3.6 (4.12.5)	Screwed glands; force (Nm) :		P
3.6 (4.13)	Mechanical strength		
3.6 (4.13.1)	Impact tests:		P
	- fragile parts; energy (Nm) :	IK08 (glass) IK08 (lenses)	P
	- other parts; energy (Nm) :		P
	1) live parts		P

IEC 60598-2-3			
Clause	Requirement + Test	Result - Remark	Verdict
	2) linings		P
	3) protection		P
	4) covers		P
3.6 (4.13.3)	Straight test finger		P
3.6 (4.13.4)	Rough service luminaires		
	- IP54 or higher		N/A
	a) fixed		N/A
	b) hand-held		N/A
	c) delivered with a stand		N/A
	d) for temporary installations and suitable for mounting on a stand		N/A
3.6 (4.13.6)	Tumbling barrel		N/A
3.6 (4.14)	Suspensions, fixings and means of adjusting		
3.6 (4.14.1)	Mechanical load:		
	A) four times the weight		N/A
	B) torque 2,5 Nm		P
	C) bracket arm; bending moment (Nm)		N/A
	D) load track-mounted luminaires		N/A
	E) clip-mounted luminaires, glass-shelve. Thickness (mm)		N/A
	Metal rod. diameter (mm)		N/A
	Fixed luminaire or independent control gear without fixing devices		N/A
3.6 (4.14.2)	Load to flexible cables		N/A
	Mass (kg)		—
	Stress in conductors (N/mm ²)		N/A
	Mass (kg) of semi-luminaire		—
	Bending moment (Nm) of semi-luminaire		N/A
3.6 (4.14.3)	Adjusting devices:		
	- flexing test; number of cycles		N/A
	- strands broken		N/A
	- electric strength test afterwards		N/A
3.6 (4.14.4)	Telescopic tubes: cords not fixed to tube; no strain on conductors		N/A
3.6 (4.14.5)	Guide pulleys		N/A
3.6 (4.14.6)	Strain on socket-outlets		N/A

IEC 60598-2-3			
Clause	Requirement + Test	Result - Remark	Verdict
3.6 (4.15)	Flammable materials		
	- glow-wire test 650°C.....:	See Test Table 3.15 (13.3.2)	N/A
	- spacing \geq 30 mm		N/A
	- screen withstanding test of 13.3.1		N/A
	- screen dimensions		N/A
	- no fiercely burning material		P
	- thermal protection		N/A
	- electronic circuits exempted		N/A
3.6 (4.15.2)	Luminaires made of thermoplastic material with lamp control gear		
	a) construction		P
	b) temperature sensing control	110	P
	c) surface temperature		N/A
3.6 (4.16)	Luminaires for mounting on normally flammable surfaces		
	No lamp control gear	(compliance with Section 12)	N/A
3.6 (4.16.1)	Lamp control gear spacing:		
	- spacing 35 mm		N/A
	- spacing 10 mm		N/A
3.6 (4.16.2)	Thermal protection:		
	- in lamp control gear		N/A
	- external		N/A
	- fixed position		N/A
	- temperature marked lamp control gear		P
3.6 (4.16.3)	Design to satisfy the test of 12.6	(see clause 12.6)	P
3.6 (4.17)	Drain holes		
	Clearance at least 5 mm		N/A
3.6 (4.18)	Resistance to corrosion		
3.6 (4.18.1)	- rust-resistance		P
3.6 (4.18.2)	- season cracking in copper		P
3.6 (4.18.3)	- corrosion of aluminium		P
3.6 (4.19)	Igniters compatible with ballast		N/A
3.6 (4.20)	Rough service vibration		N/A
3.6 (4.21)	Protective shield		
3.6 (4.21.1)	Shield fitted if tungsten halogen lamps or metal halide lamps		N/A

IEC 60598-2-3			
Clause	Requirement + Test	Result - Remark	Verdict
	Shield of glass if tungsten halogen lamps		N/A
3.6 (4.21.2)	Particles from a shattering lamp not impair safety		N/A
3.6 (4.21.3)	No direct path		N/A
3.6 (4.21.4)	Impact test on shield		N/A
	Glow-wire test on lamp compartment	See Test Table 3.15 (13.3.2)	N/A
3.6 (4.22)	Attachments to lamps not cause overheating or damage		N/A
3.6 (4.23)	Semi-luminaires comply Class II		N/A
3.6 (4.24)	Photobiological hazards		
3.6 (4.24.1)	No excessive UV radiation if tungsten halogen lamps and metal halide lamps (Annex P)		P
3.6 (4.24.2)	Retinal blue light hazard		
	Luminaires with E_{thr} :		
	a) Fixed luminaires		P
	- distance x m, borderline between RG1 and RG2 ...:	RG2@20cm RG1@50cm RG0@500cm	P
	- marking and instruction according 3.2.23		N/A
	b) Portable and handheld luminaires		
	- marking according 3.2.23 if RG1 exceeded at 200 mm according to IEC/TR 62778		N/A
	Portable luminaires for children IEC 60598-2-10 and Mains socket outlet nightlights IEC 60598-2-12 not exceed RG1 at 200 mm according to IEC/62778		N/A
3.6 (4.25)	Mechanical hazard		
	No sharp point or edges		P
3.6 (4.26)	Short-circuit protection		
3.6 (4.26.1)	Adequate means of uninsulated accessible SELV parts		N/A
3.6 (4.26.2)	Short-circuit test with test chain according 4.26.3		N/A
	Test chain not melt through		N/A
	Test sample not exceed values of Table 12.1 and 12.2		N/A
3.6 (4.27)	Terminal blocks with integrated screwless earthing contacts		
	Test according Annex V		N/A
	Pull test of terminal fixing (20 N)		N/A
	After test, resistance < 0,05 Ω		N/A
	Pull test of mechanical connection (50 N)		N/A

IEC 60598-2-3			
Clause	Requirement + Test	Result - Remark	Verdict
	After test, resistance < 0,05 Ω		N/A
	Voltage drop test, resistance < 0,05 Ω		N/A
3.6 (4.28)	Fixing of thermal sensing control		
	Not plug-in or easily replaceable type		N/A
	Reliably kept in position		N/A
	No adhesive fixing if UV radiations from a lamp can degrade the fixing		N/A
	Not outside the luminaire enclosure		N/A
	Test of adhesive fixing:		N/A
	Max. temperature on adhesive material (°C).....:		—
	100 cycles between t min and t max		N/A
	Temperature sensing control still in position		N/A
3.6 (4.29)	Luminaires with non-replaceable light source		
	Not possible to replace light source		N/A
	Live part not accessible after parts have been opened by hand or tools		N/A
3.6 (4.30)	Luminaires with non-user replaceable light source		
	If protective cover provide protection against electric shock and marked with “caution, electric shock risk” symbol:		P
	Minimum two fixing means		P
3.6 (4.31)	Insulation between circuits		
	Circuits insulated from LV supply fulfil requirements according 4.31.1 – 4.31.3	SELV/IEC 61347-2-13	P
	Controllable luminaires requiring same level of insulation for all components, the insulation between control terminals and LV supply fulfil requirements according 4.31.1 – 4.31.3		N/A
3.6 (4.31.1)	SELV circuits		P
	Used SELV source		P
	Voltage ≤ ELV		P
	Insulating of SELV circuits from LV supply	Double/reinforced	P
	Insulating of SELV circuits from other non SELV circuits		N/A
	Insulating of SELV circuits from FELV		N/A
	Insulating of SELV circuits from other SELV circuits		N/A
	SELV circuits insulated from accessible parts according Table X.1		P

IEC 60598-2-3			
Clause	Requirement + Test	Result - Remark	Verdict
	Plugs not able to enter socket-outlets of other voltage systems		N/A
	Socket outlets does not admit plugs of other voltage systems		N/A
	Plugs and socket-outlets does not have protective conductor contact		N/A
3.6 (4.31.2)	FELV circuits		
	Used FELV source		N/A
	Voltage ≤ ELV		N/A
	Insulating of FELV circuits from LV supply		N/A
	FELV circuits insulated from accessible parts according Table X 1		N/A
	Plugs not able to enter socket-outlets of other voltage systems		N/A
	Socket outlets does not admit plugs of other voltage systems		N/A
	Socket-outlets does not have protective conductor contact		N/A
3.6 (4.31.3)	Other circuits		
	Other circuits insulated from accessible parts according Table X 1		N/A
	Class II construction with equipotential bonding for protection against indirect contacts with live parts:		
	- conductive parts are connected together		N/A
	- test according 7.2.3 of above		N/A
	- conductive part not cause an electric shock in case of an insulation fault		N/A
	- equipotential bonding in master/slave applications		N/A
	- master luminaire provided with terminal for accessible conductive parts of slave luminaires		N/A
	- slave luminaire constructed as class I		N/A
3.6 (4.32)	Overvoltage protective devices		
	Comply with IEC 61643-11	CB	P
	External to controlgear and connected to earth:		
	- only in fixed luminaires		P
	- only connected to protective earth		P
3.6.1 (-)	At least IP X3 or X5 respectively. IP	IP66	P
	Column-integrated luminaires:		

IEC 60598-2-3			
Clause	Requirement + Test	Result - Remark	Verdict
	- parts below 2,5 m. IP		N/A
	- parts above 2,5 m. IP		N/A
3.6.2 (-)	Suspension on span wires		N/A
3.6.3 (-)	Means for attaching the luminaire or external parts to its support appropriate to the weight		P
3.6.3.1 (-)	Static load test		
	- drag coefficient	0.2563	P
	- loaded area (m ²)	0.014m ²	P
	- used load (N)	0.2N	P
	- measured deformation (cm/m)	0cm/m	P
	- no rotation		P
3.6.4 (-)	Adjustable lampholders		N/A
3.6.5 (-)	Luminaires installed above 5 m, glass covers shall be:		
	a) glass that fractures into small pieces (test according to 3.6.5.1), or	Safety Glass	P
	b) glass having a high impact shock resistance (test according to 3.6.5.2), or		P
	c) protected by any means to retain glass fragments		N/A
	For tunnel luminaires 3.6.5.1 apply		N/A
	Method of protection declared by the manufacturer		N/A
3.6.5.1 (-)	Protection by the use of glass that fractures into small pieces		P
	- number of particles is more than 40	48	P
3.6.5.2 (-)	Protection by the use of high impact resistant glass		P
3.6.5.2.1 (-)	Glass covers have high mechanical strength		P
	Test according IEC 62262 with test apparatus according IEC 60068-2-75 with impact energy of 5J on preconditioned sample	Glass : IK08 Lenses : IK08	P
3.6.5.2.2 (-)	Glass covers not break into large pieces		P
	- test according 3.6.5.1, number of particles is more than 20	50	P
3.6.6 (-)	Connection compartment of column-integrated luminaire		
	- provides adequate space		N/A
	- means for attachment		N/A
	- means for attachment of metal corrosion-resistant		N/A
3.6.7 (-)	Compliance with ISO standard or other		N/A
3.6.8 (-)	Doors of column-integrated luminaires:		

IEC 60598-2-3			
Clause	Requirement + Test	Result - Remark	Verdict
	- corrosion-resistant		N/A
	- opening only possible for an authorized person		N/A
	- impact test 5 Nm		N/A
	- sample show no damage		N/A
3.6.9 (-)	Column-integrated luminaire:		
	- dimension of the cable entry slot (mm)		N/A
	- cable path from the slot to the connection compartment (mm)		N/A
	- cable path free from obstruction that might cause abrasion of the cable		N/A

3.7 (11)	CREEPAGE DISTANCES AND CLEARANCES		P
3.7 (11.2)	Creepage distances and clearances	See Table 3.7 (11.2)	P
	Working voltage (V)	120-240 V	—
	Rated pulse voltage (kV)	/	—
	Voltage form	Sinusoidal <input checked="" type="checkbox"/> Non-sinusoidal <input type="checkbox"/>	—
	PTI	< 600 <input type="checkbox"/> ≥ 600 <input checked="" type="checkbox"/>	—
	Impulse withstand category (Normal category II) (Category III Annex U)	Category II <input type="checkbox"/> Category III <input type="checkbox"/>	—

3.8 (7)	PROVISION FOR EARTHING		
3.8 (7.2.1 + 7.2.3)	Accessible metal parts		P
	Metal parts in contact with supporting surface		P
	Resistance < 0,5 Ω		P
	Self-tapping screws used		N/A
	Thread-forming screws		N/A
	Thread-forming screw used in a grove		N/A
	Earth makes contact first		P
	Terminal blocks with integrated screwless earthing contacts tested according Annex V		N/A
	Protective earthing of the luminaire not via built-in control gear		P
3.8 (7.2.2 + 7.2.3)	Earth continuity in joints, etc.		P
3.8 (7.2.4)	Locking of clamping means		P

IEC 60598-2-3			
Clause	Requirement + Test	Result - Remark	Verdict
	Compliance with 4.7.3		P
	Terminal blocks with integrated screwless earthing contacts tested according Annex V		N/A
3.8 (7.2.5)	Earth terminal integral part of connector socket		P
3.8 (7.2.6)	Earth terminal adjacent to mains terminals		P
3.8 (7.2.7)	Electrolytic corrosion of the earth terminal		P
3.8 (7.2.8)	Material of earth terminal		P
	Contact surface bare metal		P
3.8 (7.2.10)	Class II luminaire for looping-in		N/A
	Double or reinforced insulation to functional earth		N/A
3.8 (7.2.11)	Earthing core coloured green-yellow		P
	Length of earth conductor		N/A
3.8.1 (-)	Attachment prevented from rotation		N/A

3.9 (14)	SCREW TERMINALS		P
	Separately approved; component list	(see Annex 1)	P
	Part of the luminaire.....	(see Annex 3)	N/A

3.9 (15)	SCREWLESS TERMINALS AND ELECTRICAL CONNECTIONS		P
	Separately approved; component list	(see Annex 1)	P
	Part of the luminaire.....	(see Annex 4)	N/A

3.10 (5)	EXTERNAL AND INTERNAL WIRING		
3.10 (5.2)	Supply connection and external wiring		P
3.10 (5.2.1)	Means of connection.....	Internal connector	P
	Outdoor luminaire has not PVC insulated external wiring if not class III or SELV ≤ 25 V a.c./60 V d.c. or protected from outdoor environment		N/A
3.10 (5.2.2)	Type of cable	H07RN-F (if provided)	P
	Nominal cross-sectional area (mm ²).....	1,5 mm ²	P
	Cables equal to IEC 60227 or IEC 60245		P
3.10 (5.2.3)	Type of attachment, X, Y or Z		N/A
3.10 (5.2.5)	Type Z not connected to screws		N/A
3.10 (5.2.6)	Cable entries:		
	- suitable for introduction		P

IEC 60598-2-3			
Clause	Requirement + Test	Result - Remark	Verdict
	- adequate degree of protection		P
3.10 (5.2.7)	Cable entries through rigid material have rounded edges		P
3.10 (5.2.8)	Insulating bushings:		
	- suitably fixed		N/A
	- material in bushings		N/A
	- material not likely to deteriorate		N/A
	- tubes or guards made of insulating material		N/A
3.10 (5.2.9)	Locking of screwed bushings		N/A
3.10 (5.2.10)	Cord anchorage:		
	- covering protected from abrasion		P
	- clear how to be effective		P
	- no mechanical or thermal stress		P
	- no tying of cables into knots etc.		P
	- insulating material or lining		P
3.10 (5.2.10.1)	Cord anchorage for type X attachment:		
	a) at least one part fixed		N/A
	b) types of cable		N/A
	c) no damaging of the cable		N/A
	d) whole cable can be mounted		N/A
	e) no touching of clamping screws		N/A
	f) metal screw not directly on cable		N/A
	g) replacement without special tool		N/A
	Glands not used as anchorage		N/A
	Labyrinth type anchorages		N/A
3.10 (5.2.10.2)	Adequate cord anchorage for type Y and type Z attachment		N/A
3.10 (5.2.10.3)	Tests:		
	- impossible to push cable; unsafe		P
	- pull test: 25 times; pull (N): 60		P
	- torque test: torque (Nm): 0.25Nm		P
	- displacement ≤ 2 mm		P
	- no movement of conductors		P

IEC 60598-2-3			
Clause	Requirement + Test	Result - Remark	Verdict
	- no damage of cable or cord		P
	- function independent of electrical connection		N/A
3.10 (5.2.11)	External wiring passing into luminaire		N/A
3.10 (5.2.12)	Looping-in terminals		N/A
3.10 (5.2.13)	Wire ends not tinned		N/A
	Wire ends tinned: no cold flow		N/A
3.10 (5.2.14)	Mains plug same protection		N/A
	Class III luminaire plug		N/A
	No unsafe compatibility		N/A
3.10 (5.2.16)	Appliance inlets (IEC 60320)		P
	Installation couplers (IEC 61535)		N/A
	Other appliance inlet or connector according relevant IEC standard		N/A
3.10 (5.2.17)	No standardized interconnecting cables properly assembled		N/A
3.10 (5.2.18)	Used plug in accordance with		
	- IEC 60083		N/A
	- other standard		N/A
3.10 (5.3)	Internal wiring		
3.10 (5.3.1)	Internal wiring of suitable size and type		P
	Through wiring		
	- not delivered/ mounting instruction		N/A
	- factory assembled		N/A
	- socket outlet loaded (A)		N/A
	- temperatures	(see Annex 2)	N/A
	Green-yellow for earth only		N/A
3.10 (5.3.1.1)	Internal wiring connected directly to fixed wiring		
	Cross-sectional area (mm ²)		P
	Insulation thickness		P
	Extra insulation added where necessary		N/A

IEC 60598-2-3			
Clause	Requirement + Test	Result - Remark	Verdict
3.10 (5.3.1.2)	Internal wiring connected to fixed wiring via internal current-limiting device		
	Adequate cross-sectional area and insulation thickness		N/A
3.10 (5.3.1.3)	Double or reinforced insulation for class II		N/A
3.10 (5.3.1.4)	Conductors without insulation		N/A
3.10 (5.3.1.5)	SELV current-carrying parts		P
3.10 (5.3.1.6)	Insulation thickness other than PVC or rubber		P
3.10 (5.3.2)	Sharp edges etc.		P
	No moving parts of switches etc.		N/A
	Joints, raising/lowering devices		N/A
	Telescopic tubes etc.		N/A
	No twisting over 360°		N/A
3.10 (5.3.3)	Insulating bushings:		
	- suitable fixed		N/A
	- material in bushings		N/A
	- material not likely to deteriorate		N/A
	- cables with protective sheath		N/A
3.10 (5.3.4)	Joints and junctions effectively insulated		N/A
3.10 (5.3.5)	Strain on internal wiring		P
3.10 (5.3.6)	Wire carriers		N/A
3.10 (5.3.7)	Wire ends not tinned		P
	Wire ends tinned: no cold flow		N/A
3.10.1 (-)	Cord anchorage if applicable		P
	- pull test: 25 times; pull (N)	60 N	P
	- torque test: torque (Nm)	0.25 Nm	P

3.11 (8)	PROTECTION AGAINST ELECTRIC SHOCK		
3.11 (8.2.1)	Live parts not accessible		P
	Basic insulated parts not used on the outer surface without appropriate protection		P

IEC 60598-2-3			
Clause	Requirement + Test	Result - Remark	Verdict
	Basic insulated parts not accessible with standard test finger on portable, settable and adjustable luminaires		P
	Basic insulated parts not accessible with Ø 50 mm probe from outside, other types of luminaires		P
	Lamp and starterholders in portable and adjustable luminaires comply with double or reinforced insulation requirements		N/A
	Basic insulation only accessible under lamp or starter replacement		N/A
	Protection in any position		N/A
	Double-ended tungsten filament lamp		N/A
	Insulation lacquer not reliable		N/A
	Double-ended high pressure discharge lamp		N/A
	Relevant warning according to 3.2.18 fitted to the luminaire		N/A
3.11 (8.2.2)	Portable luminaire adjusted in most unfavourable position		N/A
3.11 (8.2.3.a)	Class II luminaire:		
	- basic insulated metal parts not accessible during starter or lamp replacement		N/A
	- basic insulation not accessible other than during starter or lamp replacement		N/A
	- glass protective shields not used as supplementary insulation		N/A
3.11 (8.2.3.b)	BC lampholder of metal in class I luminaires shall be earthed		N/A
3.11 (8.2.3.c)	SELV circuits with exposed current carrying parts:		
	Ordinary luminaire:		
	- touch current		N/A
	- no-load voltage.....		N/A
	Other than ordinary luminaire:		
	- nominal voltage		N/A
3.11 (8.2.4)	Portable luminaire have protection independent of supporting surface		N/A
3.11 (8.2.5)	Compliance with the standard test finger or relevant probe		P
3.11 (8.2.6)	Covers reliably secured		P

IEC 60598-2-3			
Clause	Requirement + Test	Result - Remark	Verdict
3.11 (8.2.7)	Discharging of capacitors $\geq 0,5 \mu\text{F}$		N/A
	Portable plug connected luminaire with capacitor		N/A
	Other plug connected luminaire with capacitor		N/A
	Discharge device on or within capacitor		N/A
	Discharge device mounted separately		N/A

3.12 (12)	ENDURANCE TEST AND THERMAL TEST		P
3.12.2 (-)	If IP > IP 20 relevant test of (12.4), (12.5) and (12.6) after (9.2) before (9.3) specified in 3.13		—
3.12 (12.3)	Endurance test:		P
	- mounting-position	Acc. To mounting instruction	—
	- test temperature (°C)	35°C	—
	- total duration (h)	240 H	—
	- supply voltage: Un factor; calculated voltage (V):		—
	- lamp used		—
3.12 (12.3.2)	After endurance test:		
	- no part unserviceable		P
	- luminaire not unsafe		P
	- no damage to track system		N/A
	- marking legible		P
	- no cracks, deformation etc.		P
3.12 (12.4)	Thermal test (normal operation)	(see Annex 2)	P
3.12 (12.5)	Thermal test (abnormal operation)	(see Annex 2)	P
3.12 (12.6)	Thermal test (failed lamp control gear condition):		
3.12 (12.6.1)	Through wiring or looping-in wiring loaded by a current of (A)		—
	- case of abnormal conditions		—
	- electronic lamp control gear		N/A
	- measured winding temperature (°C): at 1,1 Un		—
	- measured mounting surface temperature (°C) at 1,1 Un.....		N/A
	- calculated mounting surface temperature (°C)		N/A
	- track-mounted luminaires		N/A

IEC 60598-2-3			
Clause	Requirement + Test	Result - Remark	Verdict
3.12 (12.6.2)	Temperature sensing control		
	- case of abnormal conditions		—
	- thermal link		N/A
	- manual reset cut-out		N/A
	- auto reset cut-out		N/A
	- measured mounting surface temperature (°C)		N/A
	- track-mounted luminaires		N/A
3.12 (12.7)	Thermal test (failed lamp control gear in plastic luminaires):		N/A
3.12 (12.7.1)	Luminaire without temperature sensing control		N/A
3.12 (12.7.1.1)	Luminaire with fluorescent lamp ≤ 70W		N/A
	Test method 12.7.1.1 or Annex W		—
	Test according to 12.7.1.1:		
	- case of abnormal conditions		—
	- Ballast failure at supply voltage (V)		—
	- Components retained in place after the test		N/A
	- Test with standard test finger after the test		N/A
	Test according to Annex W:		
	- case of abnormal conditions		—
	- measured winding temperature (°C): at 1,1 Un		—
	- measured temperature of fixing point/exposed part (°C): at 1,1 Un		—
	- calculated temperature of fixing point/exposed part (°C)		—
	Ball-pressure test	See Table 3.15 (13.2.1)	N/A
3.12 (12.7.1.2)	Luminaire with discharge lamp, fluorescent lamp > 70W, transformer > 10 VA		
	- case of abnormal conditions		—
	- measured winding temperature (°C): at 1,1 Un		—
	- measured temperature of fixing point/exposed part (°C): at 1,1 Un		—
	- calculated temperature of fixing point/exposed part (°C)		—
	Ball-pressure test	See Table 3.15 (13.2.1)	N/A

IEC 60598-2-3			
Clause	Requirement + Test	Result - Remark	Verdict
3.12 (12.7.1.3)	Luminaire with short circuit proof transformers ≤ 10 VA		N/A
	- case of abnormal conditions		—
	- Components retained in place after the test		N/A
	- Test with standard test finger after the test		N/A
3.12 (12.7.2)	Luminaire with temperature sensing control		N/A
	- thermal link	Yes <input type="checkbox"/> No <input type="checkbox"/>	—
	- manual reset cut-out	Yes <input type="checkbox"/> No <input type="checkbox"/>	—
	- auto reset cut-out	Yes <input type="checkbox"/> No <input type="checkbox"/>	—
	- case of abnormal conditions		—
	- highest measured temperature of fixing point/ exposed part (°C):		—
	Ball-pressure test:	See Table 3.15 (13.2.1)	N/A
3.12.1 (-)	Temperature reduction if for outdoor use only		N/A
3.12.2 (-)	(See above)		—
3.12.3 (-)	Glass covers used within the thermal limits declared by the glass manufacturer		N/A

3.13 (9)	RESISTANCE TO DUST, SOLID OBJECTS AND MOISTURE		P
3.13.1 (-)	If IP > IP 20 the order of tests as specified in clause 3.12		P
3.13 (9.2)	Tests for ingress of dust, solid objects and moisture:		—
	- classification according to IP	IP66	—
	- mounting position during test	Acc. to mounting instruction	—
	- fixing screws tightened; torque (Nm)	Acc. to mounting instruction	—
	- tests according to clauses		—
	- electric strength test afterwards		P
	a) no deposit in dust-proof luminaire		P
	b) no talcum in dust-tight luminaire		P
	c) no trace of water on current-carrying parts or on insulation where it could become a hazard		P
	d) i) For luminaires without drain holes – no water entry		P
	d) ii) For luminaires with drain holes – no hazardous water entry		N/A
	e) no water in watertight luminaire		P

IEC 60598-2-3			
Clause	Requirement + Test	Result - Remark	Verdict
	f) no contact with live parts (IP 2X)		P
	f) no entry into enclosure (IP 3X and IP 4X)		P
	f) no contact with live parts (IP3X and IP4X)		P
	g) no trace of water on part of lamp requiring protection from splashing water		N/A
	h) no damage of protective shield or glass envelope		N/A
3.13 (9.3)	Humidity test 48 h		P

3.14 (10)	INSULATION RESISTANCE AND ELECTRIC STRENGTH		P
3.14 (10.2.1)	Insulation resistance test		P
	Cable or cord covered by metal foil or replaced by a metal rod of mm Ø		—
	Insulation resistance (MΩ)		—
	SELV		
	- between current-carrying parts of different polarity :	>1,3 Mohm	P
	- between current-carrying parts and mounting surface	>1,3 Mohm	P
	- between current-carrying parts and metal parts of the luminaire	>1,3 Mohm	P
	- between the outer surface of a flexible cord or cable where it is clamped in a cord anchorage and accessible metal parts		N/A
	- Insulation bushings as described in Section 5		N/A
	Other than SELV		
	- between live parts of different polarity	>2,6 Mohm	P
	- between live parts and mounting surface	>2,6 Mohm	P
	- between live parts and metal parts	>2,6 Mohm	P
	- between live parts of different polarity through action of a switch		N/A
	- between the outer surface of a flexible cord or cable where it is clamped in a cord anchorage and accessible metal parts	>2,6 Mohm	P
	- Insulation bushings as described in Section 5		N/A
3.14 (10.2.2)	Electric strength test		P
	Dummy lamp		N/A
	Luminaires with ignitors after 24 h test		N/A

IEC 60598-2-3			
Clause	Requirement + Test	Result - Remark	Verdict
	Luminaires with manual ignitors		N/A
	Test voltage (V)		P
	SELV		
	- between current-carrying parts of different polarity :		N/A
	- between current-carrying parts and mounting surface		N/A
	- between current-carrying parts and metal parts of the luminaire		N/A
	- between the outer surface of a flexible cord or cable where it is clamped in a cord anchorage and accessible metal parts		N/A
	- Insulation bushings as described in Section 5		N/A
	Other than SELV		
	- between live parts of different polarity	1480 V	P
	- between live parts and mounting surface	1480 V	P
	- between live parts and metal parts	1480 V	P
	- between live parts of different polarity through action of a switch		N/A
	- between the outer surface of a flexible cord or cable where it is clamped in a cord anchorage and accessible metal parts	1480 V	P
	- Insulation bushings as described in Section 5		N/A
3.14 (10.3)	Touch current or protective conductor current (mA) :	<<0,5	P

3.15 (13)	RESISTANCE TO HEAT, FIRE AND TRACKING		
3.15 (13.2.1)	Ball-pressure test	See Test Table 3.15 (13.2.1)	N/A
3.15 (13.3.1)	Needle-flame test (10 s)	See Test Table 3.15 (13.3.1)	N/A
3.15 (13.3.2)	Glow-wire test (650°C)	See Test Table 3.15 (13.3.2)	N/A
3.15 (13.4)	Proof tracking test (IEC 60112)	See Test Table 3.15 (13.4)	N/A

IEC 60598-2-3			
Clause	Requirement + Test	Result - Remark	Verdict

3.7 (11.2)	TABLES: Creepage distances and clearances						p
Table 11.1	Minimum distances (mm) for a.c. (50/60 Hz) sinusoidal voltages						
RMS working voltage (V) not exceeding	50	150	250	500	750	1000	
Creepage distances							
Required basic insulation, PTI \geq 600	0,6	0,8	1,5	3	4	5,5	
Measured			>2				
Required basic insulation, PTI < 600	1,2	1,6	2,5	5	8	10	
Measured							
Required supplementary insulation PTI \geq 600	-	0,8	1,5	3	4	5,5	
Measured							
Required supplementary insulation PTI < 600	-	1,6	2,5	5	8	10	
Measured							
Required reinforced insulation	-	3,2	5	6	8	11	
Measured							
Clearances							
Required basic insulation	0,2	0,8	1,5	3	4	5,5	
Measured			>2				
Required supplementary insulation	-	0,8	1,5	3	4	5,5	
Measured							
Required reinforced insulation	-	1,6	3	6	8	11	
Measured							
Table 11.2	Minimum distances (mm) for non-sinusoidal pulse voltages						
Rated pulse voltage (peak kV)	2,0	2,5	3,0	4,0	5,0	6,0	8,0
Required clearances	1,0	1,5	2	3	4	5,5	8
Measured							
Rated pulse voltage (peak kV)	10	12	15	20	25	30	40
Required clearances	11	14	18	25	33	40	60
Measured							
Rated pulse voltage (peak kV)	50	60	80	100	-	-	-
Required clearances	75	90	130	170	-	-	-
Measured							

IEC 60598-2-3			
Clause	Requirement + Test	Result - Remark	Verdict

3.15 (13.2.1)	TABLE: Ball Pressure Test of Thermoplastics			N/A
Allowed impression diameter (mm)			—	
Object/ Part No./ Material	Manufacturer/ trademark	Test temperature (°C)	Impression diameter (mm)	
Supplementary information:				

3.15 (13.3.1)	TABLE: Needle-flame test (IEC 60695-11-5)				N/A
Object/ Part No./ Material	Manufacturer/ trademark	Duration of application of test flame (ta); (s)	Ignition of specified layer Yes/No	Duration of burning (tb) (s)	Verdict
Supplementary information:					

3.15 (13.3.2)	TABLE: Glow-wire test (IEC 60695-2-11)				N/A
Glow wire temperature		650°C		—	
Object/ Part No./ Material	Manufacturer/ trademark	Duration of application of test flame (ta); (s)	Ignition of specified layer Yes/No	Duration of burning (tb) (s)	Verdict
Any flame or glowing of the sample extinguished within 30 s of withdrawing the glow -wire, and any burning or molten drop did not ignite the underlying parts (Yes/No)					
Supplementary information:					

3.15 (13.4)	TABLE: Proof tracking test (IEC 60112)				N/A
Test voltage PTI		175 V		—	
Object/ Part No./ Material	Manufacturer/ trademark	Withstand 50 drops without failure on three places or on three specimens			Verdict
Supplementary information:					

IEC 60598-2-3			
Clause	Requirement + Test	Result - Remark	Verdict

ANNEX 1		TABLE: Critical components information					
Object / part No.	Code	Manufacturer/ trademark	Type / model	Technical data	Standard	Mark(s) of conformity ¹⁾	
Drivers	A	Meanwell	APC-8E Series	8W 50-60Hz 0,25-0,7A 200-240V Tc=75°C	IEC 61347-2-13	CB	
Drivers	A	Meanwell	PLM-12 Series	12W 50-60Hz 0,35-1,05A 110-240V Tc=75°C	IEC 61347-2-13 IEC 62384	TUV	
Drivers	A	Meanwell	PLM-25 Series	25W 50-60Hz 0,35-1,05A 110-240V Tc=80°C	IEC 61347-2-13 IEC 62384	TUV	
Drivers	A	Meanwell	PLD-16 Series	17W 50-60Hz 0,35-1,4A 200-240V Tc=70°C	IEC 61347-2-13	CB	
Drivers	A	Meanwell	PLD-25 Series	25W 50-60Hz 0,35/0,7/1,05/1,4A 100-240Vac Tc=70°C	IEC 61347-2-13	CB	
Drivers	A	Meanwell	PLD-40 Series	40W 50-60Hz 0,35-1,75A 200-240Vac Tc=90°C	IEC 61347-2-13	CB	
Driver	A	LG	PISE-A027M	27W 0,2-1A 120-277V 50-60Hz Tc=80°C	IEC 61347-2-13	CB / UL	
Driver	A	LG	PISE-A027A	27W 1A 120-277V 50-60Hz Tc=80°C	IEC 61347-2-13	CB / UL	
Drivers	A	Moons	PU025H Series	25W 50-60Hz 0,35-2,1A 100-240V Tc=90°C	IEC 61347-2-13	TUV	
Drivers	A	PHILIPS	Xi LP/FP 22W 0,3-1,0A 230V S175 sXt	22W 50-60Hz 0,3-1,05A 198-264V Tc=85°C	IEC 61347-2-13	CB	
Drivers	A	PHILIPS	Xi FP/LP 40W 0,3-1,0A 230V S175 sXt	40W 50-60Hz 0,3-1,05A 198-264V Tc=90°C	IEC 61347-2-13	CB	
Drivers	A	TRIDONIC	LCI 27W	27W 50-60Hz 1A 220-240V Tc=70°C	IEC 61347-2-13	OVE	
EMI filter	A	TE connectivity	Corcom 2FB3	I _{max} 2A V _{max} = 250Vac/d Tc 50°C	IEC 60939-2	VDE	
Surge protection Device	A	CITEL	MLPC1-230L-R	277 V, T85 10kA 20KV (DM) 120KV (CM)	IEC 61643-11	ENEC	
VDR	A	Littelfuse	TM0V	275 Vac Tc=85°C 10kA	IEC 61051-2-2	VDE	
FUSE HOLDER	A	Mersen	10x38mm CCR8-10 Series	20-32A 400V	IEC 60269-1 & -2	ENEC	
FUSE HOLDER	A	ADELS	403/503 SI	400V 10A 5x20mm	IEC 60127-1 & -6	VDE	
FUSE	A	Mersen	FR10 10x38mm	0.5-32A 400-500V	IEC 60269-1 & -2	ENEC	
FUSE	A	Littelfuse	5x20mm 213 Series	0.2-6.3A 250V	IEC 60269-1 & -2	VDE	
Terminal	A	ADELS	500 Series	0.5-4mm ² 450V	EN 60998-1&2-2	VDE	
Terminal	A	ADELS	900-07 & 08	0.5-4mm ² 450V	EN 60998-1&2-2	VDE / UL	
Terminal	A	WIELAND	ST18, GST18I	12-16A 250V 0,75-2,5mm ²	EN 60998-1&2-2	VDE / UL	

IEC 60598-2-3						
Clause	Requirement + Test			Result - Remark		Verdict

Led Modules	A	LG	6 Leds LG3535 G4TOP@1050 mA 8 Leds LG3535 G4TOP @1000 mA	RG2@20cm RG1@40cm RG0@325cm	IEC/EN 62031- 62471	Tested in appliance
Led Modules	A	LG	6 Leds LG3535 G4L@1050 mA	RG2@20cm RG1@50cm RG0@500cm	IEC/EN 62031- 62471	Tested in appliance

Supplementary information:

¹⁾ Provided evidence ensures the agreed level of compliance. See OD-CB2039.

The codes above have the following meaning:

- A - The component is replaceable with another one, also certified, with equivalent characteristics
- B - The component is replaceable if authorised by the test house
- C - Integrated component tested together with the appliance
- D - Alternative component

IEC 60598-2-3			
Clause	Requirement + Test	Result - Remark	Verdict

ANNEX 2	TABLE: Temperature measurements, thermal tests of Section 12		
	Type reference	VOLTANA-0	—
	Lamp used	6 Led's LG3535	—
	Lamp control gear used	MeanWell PLM-25 @ 1050mA	—
	Mounting position of luminaire	Horizontal	—
	Supply wattage (W)		—
	Supply current (A)		—
	Calculated power factor		—
	Table: measured temperatures corrected for $t_a = 35\text{ }^\circ\text{C}$:		
	- abnormal operating mode		—
	- test 1: rated voltage		—
	- test 2: 1,06 times rated voltage or 1,05 times rated wattage		—
	- test 3: Load on wiring to socket-outlet, 1,06 times voltage or 1,05 times wattage		—
	- test 4: 1,1 times rated voltage or 1,05 times rated wattage		—
	Through wiring or looping-in wiring loaded by a current of A during the test		—

Temperature measurements, ($^\circ\text{C}$)							
Part	Ambient	Clause 12.4 – normal				Clause 12.5 – abnormal	
		test 1	test 2	test 3	limit	test 4	limit
Convertor Tc	35	78			80		
VDR x 3 Tc	35	52			85		
Supply wiring	35	52			90		
Led Module	35	76			85		
Terminal	35	52			110		
Internal wiring	35	52			90		

Supplementary information:
Corrected for $T_a 35\text{ }^\circ\text{C}$

IEC 60598-2-3			
Clause	Requirement + Test	Result - Remark	Verdict

ANNEX 2	TABLE: Temperature measurements, thermal tests of Section 12		
	Type reference	VOLTANA-0	—
	Lamp used	6 Led's LG3535	—
	Lamp control gear used	PLD-16 @ 700 mA	—
	Mounting position of luminaire	Horizontal	—
	Supply wattage (W)		—
	Supply current (A)		—
	Calculated power factor		—
	Table: measured temperatures corrected for ta = 50 °C:		
	- abnormal operating mode		—
	- test 1: rated voltage		—
	- test 2: 1,06 times rated voltage or 1,05 times rated wattage		—
	- test 3: Load on wiring to socket-outlet, 1,06 times voltage or 1,05 times wattage		—
	- test 4: 1,1 times rated voltage or 1,05 times rated wattage		—
	Through wiring or looping-in wiring loaded by a current of A during the test		—

Temperature measurements, (°C)							
Part	Ambient	Clause 12.4 – normal				Clause 12.5 – abnormal	
		test 1	test 2	test 3	limit	test 4	limit
Convertor Tc	50	70			70		
VDR x 3 Tc	50	60			85		
Supply wiring	50	60			90		
Led Module	50	75			85		
Terminal	50	60			110		
Internal wiring	50	60			90		

Supplementary information:
Corrected for Ta 50 °C

IEC 60598-2-3			
Clause	Requirement + Test	Result - Remark	Verdict

ANNEX 2	TABLE: Temperature measurements, thermal tests of Section 12		
	Type reference	VOLTANA-0	—
	Lamp used	8 Led's LG3535	—
	Lamp control gear used	LCI 27W @ 1000mA	—
	Mounting position of luminaire	Horizontal	—
	Supply wattage (W)		—
	Supply current (A)		—
	Calculated power factor		—
	Table: measured temperatures corrected for $t_a = 30\text{ }^\circ\text{C}$:		
	- abnormal operating mode		—
	- test 1: rated voltage		—
	- test 2: 1,06 times rated voltage or 1,05 times rated wattage		—
	- test 3: Load on wiring to socket-outlet, 1,06 times voltage or 1,05 times wattage		—
	- test 4: 1,1 times rated voltage or 1,05 times rated wattage		—
	Through wiring or looping-in wiring loaded by a current of A during the test		—

Temperature measurements, (°C)							
Part	Ambient	Clause 12.4 – normal				Clause 12.5 – abnormal	
		test 1	test 2	test 3	limit	test 4	limit
Convertor Tc	30	64			70		
SPD Tc	30	53			85		
Supply wiring	30	53			90		
Led Module	30	80			85		
Terminal	30	53			110		
Internal wiring	30	53			90		

Supplementary information:
Corrected for $T_a 30\text{ }^\circ\text{C}$

IEC 60598-2-3			
Clause	Requirement + Test	Result - Remark	Verdict

ANNEX 2	TABLE: Temperature measurements, thermal tests of Section 12		
	Type reference	VOLTANA-0	—
	Lamp used	8 Led's LG3535	—
	Lamp control gear used	Philips 40W @ 1050mA	—
	Mounting position of luminaire	Horizontal	—
	Supply wattage (W)		—
	Supply current (A)		—
	Calculated power factor		—
	Table: measured temperatures corrected for $t_a = 35\text{ }^\circ\text{C}$:		
	- abnormal operating mode		—
	- test 1: rated voltage		—
	- test 2: 1,06 times rated voltage or 1,05 times rated wattage		—
	- test 3: Load on wiring to socket-outlet, 1,06 times voltage or 1,05 times wattage		—
	- test 4: 1,1 times rated voltage or 1,05 times rated wattage		—
	Through wiring or looping-in wiring loaded by a current of A during the test		—

Temperature measurements, (°C)							
Part	Ambient	Clause 12.4 – normal				Clause 12.5 – abnormal	
		test 1	test 2	test 3	limit	test 4	limit
Convertor Tc	30	84			90		
SPD Tc	30	53			85		
Supply wiring	30	53			90		
Led Module	30	74			85		
Terminal	30	53			110		
Internal wiring	30	53			90		

Supplementary information:
Corrected for $T_a 35\text{ }^\circ\text{C}$

IEC 60598-2-3			
Clause	Requirement + Test	Result - Remark	Verdict

ANNEX 2	TABLE: Temperature measurements, thermal tests of Section 12		
	Type reference	VOLTANA-0	—
	Lamp used	6 Led's LG3535	—
	Lamp control gear used.....	Moons @ 1050mA (MeanWell @ 350mA)	—
	Mounting position of luminaire	Horizontal	—
	Supply wattage (W).....		—
	Supply current (A).....		—
	Calculated power factor.....		—
	Table: measured temperatures corrected for ta = 20 °C (35°C):		
	- abnormal operating mode.....		—
	- test 1: rated voltage		—
	- test 2: 1,06 times rated voltage or 1,05 times rated wattage		—
	- test 3: Load on wiring to socket-outlet, 1,06 times voltage or 1,05 times wattage		—
	- test 4: 1,1 times rated voltage or 1,05 times rated wattage		—
	Through wiring or looping-in wiring loaded by a current of A during the test		—

Temperature measurements, (°C)							
Part	Ambient	Clause 12.4 – normal				Clause 12.5 – abnormal	
		test 1	test 2	test 3	limit	test 4	limit
Convertor Tc	20 (35°C)	42 (57)			90 (75)		
SPD Tc	20 (35°C)	33 (38)			85		
Supply wiring	20 (35°C)	33 (38)			90		
Led Module	20 (35°C)	74 (45)			85		
Terminal	20 (35°C)	33 (38)			110		
Internal wiring	20 (35°C)	33 (38)			90		
EMI filter	(35°C)	(45)			50		

Supplementary information:
Corrected for Ta 20°C (35°C)

IEC 60598-2-3			
Clause	Requirement + Test	Result - Remark	Verdict

ANNEX 3	Screw terminals (part of the luminaire)		N/A
(14)	SCREW TERMINALS		N/A
(14.2)	Type of terminal		—
	Rated current (A)		—
(14.3.2.1)	One or more conductors		N/A
(14.3.2.2)	Special preparation		N/A
(14.3.2.3)	Terminal size		N/A
	Cross-sectional area (mm ²)		—
(14.3.3)	Conductor space (mm)		N/A
(14.4)	Mechanical tests		N/A
(14.4.1)	Minimum distance		N/A
(14.4.2)	Cannot slip out		N/A
(14.4.3)	Special preparation		N/A
(14.4.4)	Nominal diameter of thread (metric ISO thread)		N/A
	External wiring		N/A
	No soft metal		N/A
(14.4.5)	Corrosion		N/A
(14.4.6)	Nominal diameter of thread (mm)		N/A
	Torque (Nm)		N/A
(14.4.7)	Between metal surfaces		N/A
	Lug terminal		N/A
	Mantle terminal		N/A
	Pull test; pull (N)		N/A
(14.4.8)	Without undue damage		N/A

ANNEX 4	Screwless terminals (part of the luminaire)		N/A
(15)	SCREWLESS TERMINALS		N/A
(15.2)	Type of terminal		—
	Rated current (A)		—
(15.3.1)	Material		N/A
(15.3.2)	Clamping		N/A

IEC 60598-2-3			
Clause	Requirement + Test	Result - Remark	Verdict
(15.3.3)	Stop		N/A
(15.3.4)	Unprepared conductors		N/A
(15.3.5)	Pressure on insulating material		N/A
(15.3.6)	Clear connection method		N/A
(15.3.7)	Clamping independently		N/A
(15.3.8)	Fixed in position		N/A
(15.3.10)	Conductor size		N/A
	Type of conductor		N/A
(15.5.1)	Terminals internal wiring		N/A
(15.5.1.1)	Pull test spring-type terminals (4 N, 4 samples)		N/A
(15.5.1.2)	Pull test pin or tab terminals (4 N, 4 samples)		N/A
	Insertion force not exceeding 50 N		N/A
(15.5.1.2)	Permanent connections: pull-off test (20 N)		N/A
(15.5.2)	Electrical tests		N/A
	Voltage drop (mV) after 1 h (4 samples)		N/A
	Voltage drop of two inseparable joints		N/A
	Number of cycles:		—
	Voltage drop (mV) after 10th alt. 25th cycle (4 samples)		N/A
	Voltage drop (mV) after 50th alt. 100th cycle (4 samples)		N/A
	After ageing, voltage drop (mV) after 10th alt. 25th cycle (4 samples)		N/A
	After ageing, voltage drop (mV) after 50th alt. 100th cycle (4 samples)		N/A
(15.6)	Terminals external wiring		N/A
	Terminal size and rating		N/A
(15.6.2.1)	Pull test spring-type terminals or welded connections (4 samples); pull (N)		N/A
	Pull test pin or tab terminals (4 samples); pull (N)		N/A

IEC 60598-2-3										
Clause	Requirement + Test	Result - Remark							Verdict	

(15.6.3.1)	TABLE: Contact resistance test										N/A
	Voltage drop (mV) after 1 h										—
terminal	1	2	3	4	5	6	7	8	9	10	
voltage drop (mV)											
	Voltage drop of two inseparable joints										N/A
	Voltage drop after 10th alt. 25th cycle										N/A
	Max. allowed voltage drop (mV).....:										—
terminal	1	2	3	4	5	6	7	8	9	10	
voltage drop (mV)											
	Voltage drop after 50th alt. 100th cycle										N/A
	Max. allowed voltage drop (mV).....:										—
terminal	1	2	3	4	5	6	7	8	9	10	
voltage drop (mV)											
	Continued ageing: voltage drop after 10th alt. 25th cycle										N/A
	Max. allowed voltage drop (mV).....:										—
terminal	1	2	3	4	5	6	7	8	9	10	
voltage drop (mV)											
	Continued ageing: voltage drop after 50th alt. 100th cycle										N/A
	Max. allowed voltage drop (mV).....:										—
terminal	1	2	3	4	5	6	7	8	9	10	
voltage drop (mV)											
Supplementary information:											

IEC 60598-2-3			
Clause	Requirement + Test	Result - Remark	Verdict

Installation notice and Pictures

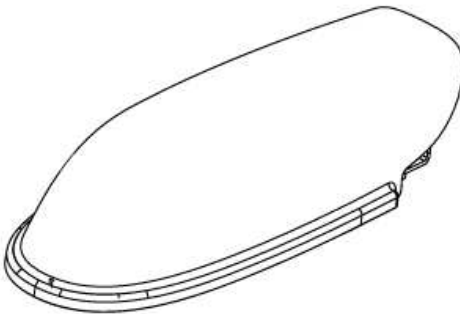



Schröder 

VOLTANA 0

IK
08

--	--	--	--	--	--	--	--	--	--	--

ENG	The light source fitted in this luminaire shall only be replaced by a Schröder employee or agent or a similar qualified person.	UKR	Джерело світла, встановлене в цій світлофікс, підлягає заміні лише працівником спеціалізованої фірми.	NLD	De lichtbron in dit verlichtingsapparaat zal alleen vervangen worden door een toedienings- agent of vergelijkbaar gekwalificeerd persoon van Schröder.	ROH	Surse de lumină încorporată în acest aparat de iluminat va fi înlocuită doar de către un angajat al Schröder, de un agent al companiei sau de o persoană cu calificări similare.
SPA	La fuente de luz instalada en esta luminaria solo puede ser sustituida por Schröder o un agente cualificado.	ITA	La sorgente luminosa montata in questo apparecchio potrà essere sostituita esclusivamente da un addetto Schröder o da una persona peritrici qualificata.	DEU	Die eingebaute Lichtquelle in der Leuchte sollte nur von einem Schröder Mitarbeiter oder Vertreter oder einer ähnlichen qualifizierten Person ersetzt werden.	HUN	A lámpatesterő szerelt fényforrás (LED-modul) cseréjét csak a gyártó, annak szerelői szakszolgálat, vagy erre kiképzett szakember végezheti!
FRA	La source de lumière intégrée dans ce luminaire peut uniquement être remplacée par un employé de Schröder, un agent ou une autre personne qualifiée.	POL	Źródło światła zamontowane w tej oprawie może być tylko wymienione przez pracownika Schröder lub przez inną wykwalifikowaną osobę.	POR	A fonte de luz montada nesta luminária só pode ser substituída por um funcionário ou agente de Schröder ou por profissional qualificado autorizado para o efeito.	SRP	Zamenu svetilnog izvora ugrađenog u ova svetiljka će izvesti samo Schröder-ov radnik, ovlašteni predstavnik ili slična stručna osoba.
CHI	该灯具内的光源仅可由施耐德员工、指定代理商或具备类似资质的人员进行更换。	VIE	Nguồn sáng được lắp đặt bên trong bộ đèn này chỉ được thay thế bởi nhân viên Schröder hoặc đại lý hoặc người có trình độ tương đương.	RUS	Источник света, установленный в этом светильнике, должен заменяться только сотрудниками Schröder, или специалистами аналогичной квалификации.	SLK	Výmena svetelného zdroja (LED modul) je možná len výrobcom, resp. len inou vyškolenými osobami!

A

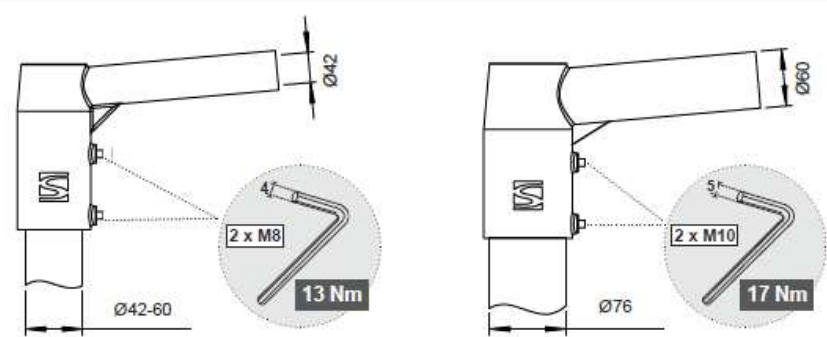

IEC 60598-2-3			
Clause	Requirement + Test	Result - Remark	Verdict

1

2

3

4

5

	Ø42	Ø48	Ø60
-15°	M8 x 45	M8 x 70	
-10°			
-5°			
0°			
+5°			

2x M8 x 70
2x M8 x 45

IEC 60598-2-3			
Clause	Requirement + Test	Result - Remark	Verdict

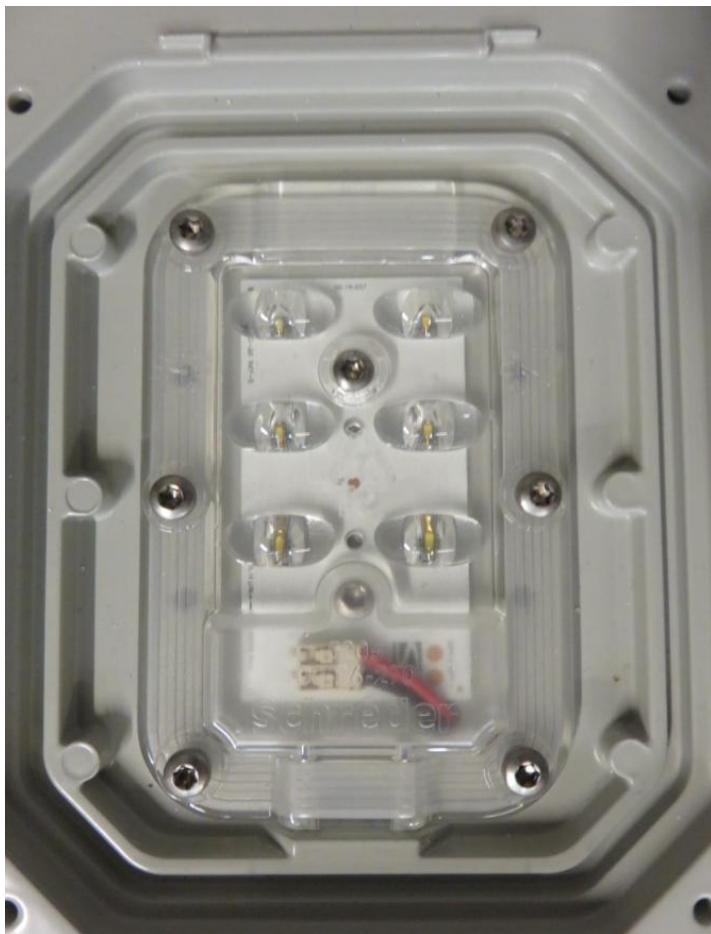

IEC 60598-2-3			
Clause	Requirement + Test	Result - Remark	Verdict

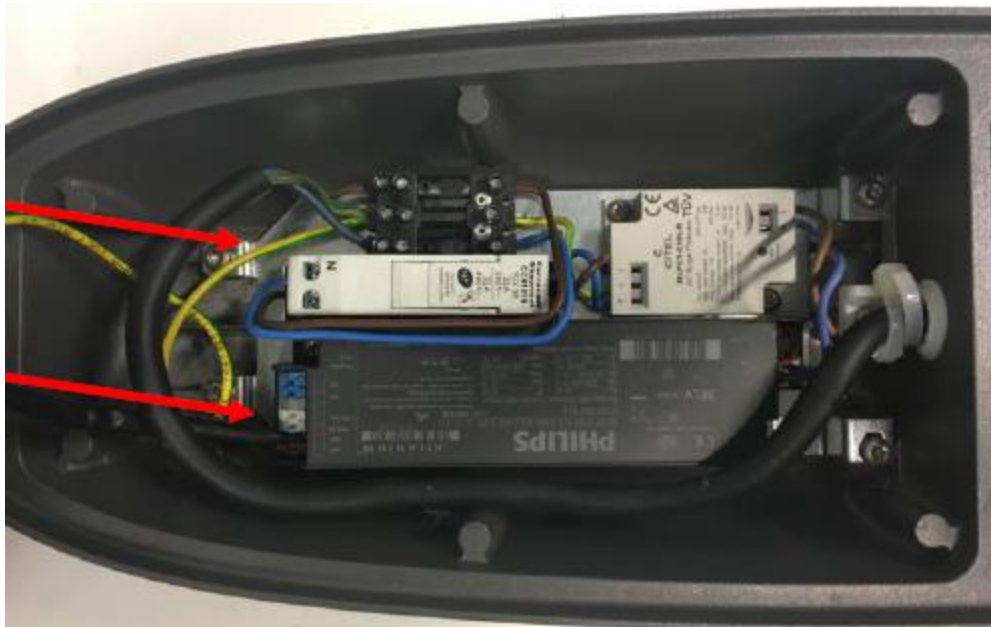

IEC60598_2_3K - ATTACHMENT

Clause	Requirement – Test	Result - Remark	Verdict
--------	--------------------	-----------------	---------

ATTACHMENT TO TEST REPORT IEC 60598-2-3
EUROPEAN GROUP DIFFERENCES AND NATIONAL DIFFERENCES
LUMINAIRES
PART 2: PARTICULAR REQUIREMENTS
SECTION 3: LUMINAIRES FOR ROAD AND STREET LIGHTING

Differences according to : EN 60598-2-3:2003 + A1:2011 used in conjunction with EN 60598-1:2015

Annex Form No. : EU_GD_IEC60598_2_3K

Annex Form Originator : IMQ S.p.A.

Master Annex Form..... : 2016-12

Copyright © 2016 IEC System for Conformity Testing and Certification of Electrical Equipment (IECEE), Geneva, Switzerland. All rights reserved.

	CENELEC COMMON MODIFICATIONS (EN)	P
--	--	----------

3.5 (3)	MARKING	P
----------------	----------------	----------

3.5 (3.3.101)	For luminaires not supplied with terminal block: Adequate warning on the package	N/A
---------------	---	-----

3.6 (4)	CONSTRUCTION	
----------------	---------------------	--

3.6 (4.11.6)	Electro-mechanical contact systems	N/A
--------------	------------------------------------	-----

3.10 (5)	EXTERNAL AND INTERNAL WIRING	
-----------------	-------------------------------------	--

3.10 (5.2.1)	Connecting leads	N/A
--------------	------------------	-----

	- without a means for connection to the supply	N/A
--	--	-----

	- terminal block specified	N/A
--	----------------------------	-----

	- relevant information provided	N/A
--	---------------------------------	-----

	- compliance with 4.6, 4.7.1, 4.7.2, 4.10.1, 11.2, 12 and 13.2 of Part 1	N/A
--	--	-----

3.10 (5.2.2)	Cables equal to EN 50525	N/A
--------------	--------------------------	-----

	Replace table 5.1 – Supply cord	N/A
--	---------------------------------	-----

3.12 (12)	ENDURANCE TESTS AND THERMAL TESTS	
------------------	--	--

3.12 (12.4.2c)	Thermal test (normal operation) see footnote c to table 12.2 relating to unsleeved fixed wiring	N/A
----------------	--	-----

ZB	ANNEX ZB, SPECIAL NATIONAL CONDITIONS (EN)	
-----------	---	--

(3.3)	DK: power supply cords of class I luminaires with label	N/A
-------	---	-----

(4.5.1)	DK: socket-outlets	N/A
---------	--------------------	-----

IEC60598_2_3K - ATTACHMENT

Clause	Requirement – Test	Result - Remark	Verdict
--------	--------------------	-----------------	---------

(5.2.1)	CY, DK, FI, GB: type of plug		
---------	------------------------------	--	--

ZC	ANNEX ZC, NATIONAL DEVIATIONS (EN)		
(4 & 5)	FR: Shuttered socket-outlets 10/16A		N/A
	FR: Safety requirements for high buildings (Arrêté du 30 décembre 2011 portant règlement de sécurité pour la construction des immeubles de grande hauteur et leur protection contre les risques d'incendie et de panique; Section VIII; Article GH 48, Eclairage) Glow-wire test for outer parts of luminaires:		
	- 850°C for luminaires in stairways and horizontal travel paths		N/A
	- 650°C for indoor luminaires		N/A
	GB: Requirements according to United Kingdom Building Regulation		N/A