

A.76

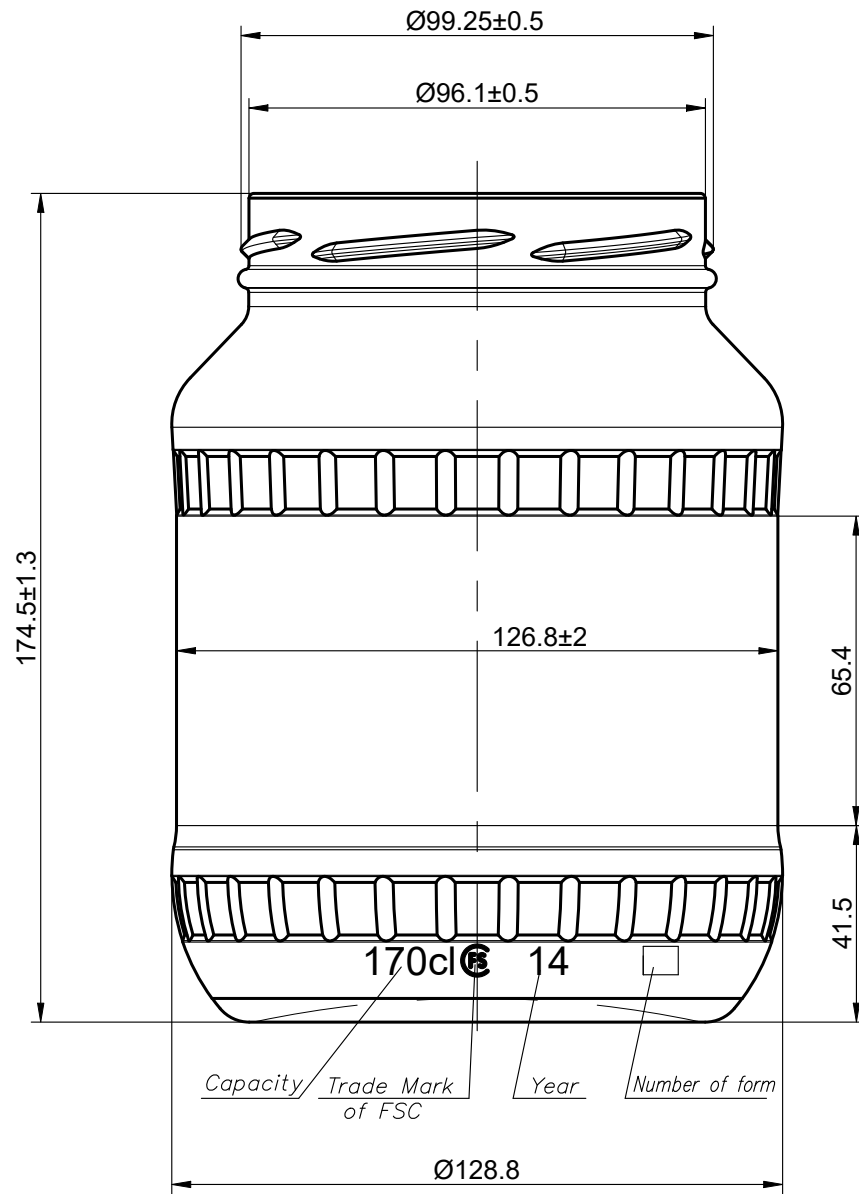

Characteristics

Full capacity, cm^3 - 1730 ± 17
 Weight recommended, g - 595

Thickness of walls not less, mm - 1.4
 Thickness of a bottom not less, mm - 2.4
 Thermal stability, difference of temperatures, not less, $^{\circ}\text{C}$ - 40
 Internal hydrostatic pressure not less, kgf/cm^2 - 2.5
 Resistance to effort of compression not less, N - 2200

Change	Letter	Document N	Signature	Date
Designed		Cosovschi P.		26.03.25
Constr. principal		Cosovschi P.		26.03.25
Dir. of manuf.		Baltaji I.		

A.76

Jar
 III-100-1700 "Livio"

Flint

Letter	Weight	Scale
		1:1
Sheet 1	Sheets 4	
FSC		FS