



## THE TESTING & CALIBRATING LABORATORY

Testing and calibrating laboratory accredited by Polish Centre for Accreditation, a signatory to EA MLA and ILAC MRA that include recognition of calibration certificates and test reports. Accreditation No AB 022 and AP 102



AB 022



Test fields: acoustics, electrotechnics, mechanics, vibrations, photometry, chemical and physical properties, functionality, safety, electromagnetic compatibility, fire resistance, flammability, climatic and mechanical hazard resistance.

## Test Report No 400/NZL/NBW/2014/O

Test object:	The surge protection devices marked: NNO 10/280, NNO 10/440
Applicant:	IzoElektro d.o.o. Limbuška cesta 2, SI – 2341 Limbuš
Manufacturer:	as above
Mark and date of commission:	9/14C-PL/0001623 / 02.10.2014
Type of tests	Safety
Standard:	PN-EN 61643-11:2013 PN-EN 60112:2003+A1:2010 PN-EN 60695-10-2:2014
Number of pages of test report:	8
Number of attachments:	0
Date of receipt of test item:	15.12.2014
Date of start of test:	17.12.2014
Date of end of test:	12.02.2015
Final result of tests:	---
Additional information:	---

Warsaw, 20<sup>th</sup> February 2015

Authorized by:  
Manager of SBF

Approved by:  
Head of the Laboratory

Dariusz Grochowina, Eng.

Robert Franaszek, M.Sc.

*This report shall not be reproduced except in full without the written approval of the testing laboratory.*

*The test results presented in this report relate only to the object tested.*

## I. TESTED OBJECT CHARACTERISTICS

**Tested object description .....**

Trademark .....: Izoelektro

Model/Type .....: NNO 10/280

Ratings .....:  $I_n = 10 \text{ kA}$ ;  $U_p = 2,0 \text{ kV}$ ;  $U_c = 280 \text{ Vac}/355 \text{ Vdc}$ ; 50/60 Hz

Additional information .....: New objects

**Photographic identification of tested objects**



**Tested object description** .....

Trademark .....: Izoelektro

Model/Type .....: NNO 10/440

Ratings .....:  $I_n = 10 \text{ kA}$ ;  $U_p = 2,0 \text{ kV}$ ;  $U_c = 440 \text{ Vac}/585 \text{ Vdc}$ ; 50/60 Hz

Additional information .....: New objects

**Photographic identification of tested objects**



## II. TEST PROGRAM

According to the order, the tests program contained all applicable measurements, necessary for check:

- 1) ball pressure test,
- 2) tracking resistance,
- 3) insulation resistance,
- 4) air clearances and creepage distances

of delivered objects, in test conditions specified in PN-EN 61643-11:2013 standard.

## III. TEST RESULT

Re 1 Ball pressure test.

Specimen was tested in the following environmental conditions:

1. Relative humidity  $R_H = (49 - 53) \% \pm 5\%$
2. Ambient temperature  $T_a = (22,2 - 22,6) ^\circ\text{C} \pm 0,5 ^\circ\text{C}$

Test conditions:

1. Time of stabilization in above environment conditions - 24 h

2. Level of test severity:

- test temperature:  $70 ^\circ\text{C} \pm 2 \text{ K}$

- exposure time  $t_a = 1 \text{ h}$

3. Kind of preparation of specimen to test: cut sample

4. Specimen dimension: 20 mm x 20 mm x 3 mm

The results of tests summarized in below table:

Tested object	Number of specimen	Place on or part of sample subjected to test	The spherical portion of the indentation left by the pressure ball (dimension D) [mm]	Test result
NNO 10/280, NNO 10/440	1	Middle of the sample	$0,3 \pm 0,1$	positive

Re 2 Tracking resistance.

Specimens were tested in the following environmental conditions:

1. Relative humidity  $R_H = (47 - 58) \% \pm 5\%$
2. Ambient temperature  $T_a = (21,2 - 22,4) ^\circ\text{C} \pm 0,2 ^\circ\text{C}$

Identification of tested specimens, information about the test preparation and the test result:

1.	Time of stabilization in above environment conditions:	24h
2.	Specimen dimension:	20 mm x 20 mm x 5 mm (2 layers)
3.	Kind of preparation of specimens to test:	cut samples, cleaned
4.	State of the surface:	the original surface of the material, no scratches
5.	Cleaning procedure:	electrode was purified by sandpaper
6.	Airflow:	tests were performed in a draught free space
7.	Orientation of the electrodes:	In accordance with clause 7.1 of PN-EN 60112:2 standard. The force exerted by each electrode on the surface of the test specimen was equal to $1,00 \text{ N} \pm 0,05 \text{ N}$

**Test result: CTI 175**

Re 3 Insulation resistance.

Before the test samples were kept in the humidity cabinet for 48 hours at a relative humidity of  $93\% \pm 3\%$  and a temperature  $(24,7 - 25,3) ^\circ\text{C} \pm 0,2 ^\circ\text{C}$ . Samples were removed from the cabin and after 30 min insulation resistance was measured. The results of tests summarized in below table:

Tested object	Resistance of insulation between:	Result
NNO 10/280	live parts and the SPD body	>50 M $\Omega$
NNO 10/440	live parts and the SPD body	>50 M $\Omega$

Re 4 Air clearances and creepage distances.

$U_{max}$	Air clearances without accessory			Creepage distances without accessory			
	minimum limit (mm)	measured length		minimum limit (mm)		measured length	
	NNO 10/280 NNO 10/440	NNO 10/280	NNO 10/440	NNO 10/280	NNO 10/440	NNO 10/280	NNO 10/440
Between live parts of different polarity	≥3	36	38	≥5	≥8	39	41
Between live parts and:							
- screws and other means to fasten a covering, having to be detached for mounting the SPD	≥3	-	-	≥5	≥8	-	-
- fastening surfaces	≥6	-	-	≥5	≥8	-	-
- screws or other means for fastening the SPD	≥6	-	-	≥5	≥8	-	-
- bodies	≥3	-	-	≥5	≥8	-	-
Between the metal parts of the disconnector mechanism and:							
- bodies	≥3	-	-	≥5	≥8	-	-
- screws or other means for fastening the SPD	≥3	-	-	≥5	≥8	-	-

TESTING & CALIBRATING LABORATORY OF THE ELECTROTECHNICAL INSTITUTE

U <sub>max</sub>	Air clearances with Connector P2			Creepage distances with Connector P2			
	minimum limit (mm)	measured length		minimum limit (mm)		measured length	
	NNO 10/280 NNO 10/440	NNO 10/280	NNO 10/440	NNO 10/280	NNO 10/440	NNO 10/280	NNO 10/440
Between live parts of different polarity	≥3	39	41	≥5	≥8	41	43
Between live parts and:							
- screws and other means to fasten a covering, having to be detached for mounting the SPD	≥3	-	-	≥5	≥8	-	-
- fastening surfaces	≥6	-	-	≥5	≥8	-	-
- screws or other means for fastening the SPD	≥6	-	-	≥5	≥8	-	-
- bodies	≥3	0,4	0,4	≥5	≥8	0,4	0,4
Between the metal parts of the disconnector mechanism and:							
- bodies	≥3	-	-	≥5	≥8	-	-
- screws or other means for fastening the SPD	≥3	-	-	≥5	≥8	-	-

**TESTING & CALIBRATING LABORATORY OF THE ELECTROTECHNICAL INSTITUTE**

U <sub>max</sub>	Air clearances with Connector P3			Creepage distances with Connector P3			
	minimum limit (mm)	measured length		minimum limit (mm)		measured length	
	NNO 10/280 NNO 10/440	NNO 10/280	NNO 10/440	NNO 10/280	NNO 10/440	NNO 10/280	NNO 10/440
Between live parts of different polarity	≥3	39	41	≥5	≥8	41	43
Between live parts and:							
- screws and other means to fasten a covering, having to be detached for mounting the SPD	≥3	-	-	≥5	≥8	-	-
- fastening surfaces	≥6	-	-	≥5	≥8	-	-
- screws or other means for fastening the SPD	≥6	-	-	≥5	≥8	-	-
- bodies	≥3	8	8	≥5	≥8	9	9
Between the metal parts of the disconnector mechanism and:							
- bodies	≥3	-	-	≥5	≥8	-	-
- screws or other means for fastening the SPD	≥3	-	-	≥5	≥8	-	-

Tested by: Józef Stańczuk





## THE TESTING & CALIBRATING LABORATORY

Testing and calibrating laboratory accredited by Polish Centre for Accreditation, a signatory to EA MLA and ILAC MRA that include recognition of calibration certificates and test reports. Accreditation No AB 022 and AP 102



AB 022



Test fields: acoustics, electrotechnics, mechanics, vibrations, photometry, chemical and physical properties, functionality, safety, electromagnetic compatibility, fire resistance, flammability, climatic and mechanical hazard resistance.

### Test Report No 178/NZL/NBW/2014/O

Test object:	The Surge Protection Devices: NNO 10/280, NNO 10/440
Applicant:	IzoElektro d.o.o. Limbuška cesta 2, SI – 2341 Limbuš
Manufacturer:	as above
Mark and date of commission:	3/13 B-PL/1623 / 13.05.2014
Type of tests	Flammability
Standard:	PN-EN 60695-2-10:2013 (in accordance with the IEC 60695-2-10:2013) PN-EN 60695-2-11:2005 (in accordance with the IEC 60695-2-11:2001 + AC1:2000) IEC 61643-11:2011
Number of pages of test report:	4
Number of attachments:	0
Date of receipt of test item:	13.05.2014
Date of start of test:	21.05.2014
Date of end of test:	21.05.2014
Final result of tests:	The tested object have been found in comply with the requirements of above standards.
Additional information:	---

Warsaw, 6<sup>th</sup> June 2014

Authorized by:

Manager of SBF

Dariusz Grochowina, Eng.

Zespół Laboratoriów  
INSTYTUTU ELEKTROTECHNIKI  
ul. Pożaryskiego 28, 04-703 Warszawa  
tel. (22) 812-30-53; fax (22) 812-04-06  
tel. (22) 812-23-38; fax (22) 812-04-07  
e-mail: badania@iel.waw.pl, nwr@iel.waw.pl  
NIP 525-000-76-84

Approved by:

Head of the Laboratory

Robert Franaszek, M.Sc.

*This report shall not be reproduced except in full without the written approval of the testing laboratory.*

*The test results presented in this report relate only to the object tested.*

Address:  
Mieczysława Pożaryskiego 28 St  
04-703 WARSZAWA

Bank: Pekao S.A.  
Account Number: 90 1240 6074 1111 0000 4999 4364  
NIP: 525-000-76-84

Ph.: (0-22) 812 30 53  
Fax: (0-22) 812 04 06  
badania@iel.waw.pl

## I. TESTED OBJECT CHARACTERISTICS

**Tested object description** .....

Trademark .....: Izoelektro

Model/Type .....: NNO 10/280

Ratings .....:  $I_n = 10 \text{ kA}$ ;  $U_p = 2,0 \text{ kV}$ ;  $U_c = 280 \text{ Vac}/355 \text{ Vdc}$ ; 50/60 Hz

Additional information .....: New objects

**Photographic identification of tested objects**



**Tested object description** .....

Trademark .....: Izoelektro

Model/Type .....: NNO 10/440

Ratings .....:  $I_n = 10 \text{ kA}$ ;  $U_p = 2,0 \text{ kV}$ ;  $U_c = 440 \text{ Vac}/585 \text{ Vdc}$ ; 50/60 Hz

Additional information .....: New objects

**Photographic identification of tested objects**



## II. TEST PROGRAM

According to the order, the test program contained all applicable tests and measurements, necessary for check of delivered objects resistance to heat, in test conditions specified in PN-EN 60695-2-11:2005 standard. Detailed list of test cases has been placed in III part of this Test Report.

## III. TEST RESULT

Specimens were tested in the following environmental conditions:

1. Relative humidity  $R_H = (46 - 51) \% \pm 5\%$
2. Ambient temperature  $T_a = (20,1 - 20,6) ^\circ\text{C} \pm 0,2 ^\circ\text{C}$

Test conditions:

1. Time of stabilization in above environment conditions - 24 h
2. Level of test severity:
  - test temperature:  $850 ^\circ\text{C} \pm 15 \text{ K}$
  - exposure time  $t_a = 30 \text{ s}$
3. The depth of penetration of glow wire in tested specimen:  $\leq 7 \text{ mm} \pm 0,5 \text{ mm}$
4. Kind of preparation of specimens to tests - finished products
5. Specimen's position during the test: long axis situated vertically

The results of tests summarized in below table:

Typ	Number of specimen	Place on or part of sample subjected to test	Ignition of test specimen during the test	Glowing of test specimen during the test	Time to ignition of the specimen $t_i$ (s)	Duration of burning $t_e$ (s)	Duration of glowing $t_e$ (s)	Limit of burning and/or glowing time (s)	The maximum height of the flame (mm)	Removal of burning material with glow wire	Ignition of the tissue paper	Test result
NNO 10/280	1	gray part of SPD	no	no	-	-	-	≤60	-	no	no	positive
NNO 10/440	2	gray part of SPD	no	no	-	-	-		-	no	no	positive

Tested by: Józef Stańczuk



**ZESPÓŁ LABORATORIÓW INSTYTUTU ELEKTROTECHNIKI**  
**LABORATORIUM BADAWCZE APARATURY ROZDZIELCZEJ**

M. Pożaryskiego str. 28, 04-703 WARSAW

phone. +(48) 22 11 25 300, email: zwarcia@iel.waw.pl



*Testing Laboratory is accredited by Polish Centre of Accreditation,  
signatory of the agreements EA MLA and ILAC MRA. Accreditation No. AB 074*

AB 074

**TEST REPORT No. 8602/NZL/NBR/15**

Test object:

Surge Protective Devices (SPD)

Client:

IzoElektro d.o.o.  
Limbuška cesta 2  
SI-2341 Limbuš, EU

Manufacturer:

IzoElektro d.o.o.  
Limbuška cesta 2  
SI-2341 Limbuš, EU

Test specification:

Type tests

Normative document(s):

EN 61643-11:2012

Reference/Order  
number:

505/022800/013  
505/024100/013

Date of tests  
completion:

February 2015

Test results:

Passed

Test manager

mgr inż. Janusz Bandel

Authorised by

mgr inż. Michał Babiuch

Head of Laboratories of  
the Electrotechnical  
Institute

mgr inż. Robert Franaszek

WARSAW, 12.03.2015.

The Test Report applies only to the apparatus tested. The responsibility for conformity of any apparatus having the same designators with that tested rests with the Manufacturer.

© Only integral reproduction of this Test Report is permitted without written permission from Laboratory

SUMMARY OF TESTS

SUMMARY OF TESTS.....	2
1. LIST OF APPLICABLE STANDARDS .....	3
2. RATINGS ASSIGNED BY THE MANUFACTURER AND PROVED BY TESTS.....	3
3. BASIC IDENTIFICATIONS DATA .....	3
4. TYPE TEST.....	4
1. Identification and marking.....	4
2. Terminals and connections .....	4
Reliability of screws, current-carrying parts and connections.....	4
Pigtail connections (flying leads) .....	4
3. Testing for protection against direct contact .....	5
4. IP code .....	5
5. Residual current.....	5
6. Operating duty test for test class II.....	7
NNO 5/440 .....	8
NNO 10/440 .....	15
7. Thermal stability.....	21
8. Air clearances and creepage distances.....	27
9. Ball pressure test.....	27
10. Resistance to abnormal heat and fire.....	27
11. Tracking resistance .....	27
12. Residual voltage .....	28
13. Insulation resistance .....	33
14. Dielectric withstand.....	33
15. Mechanical strength – Impact test.....	35
16. Temperature withstand .....	37
17. Heat resistance.....	38
18. TOVs caused by faults or disturbances in the low voltage system.....	38
19. TOVs caused by faults in the high (medium) voltage system .....	38
20. Short-circuit current behaviour.....	38
5. IDENTIFICATION DOCUMENTATION. DRAWINGS.....	39

## 1. LIST OF APPLICABLE STANDARDS

Standards:

EN 61643-11:2012	Low-voltage surge protective devices - Part 11: Surge protective devices connected to low-voltage power systems – Requirements and test methods.
IEC 61643-11:2011	Low-voltage surge protective devices - Part 11: Surge protective devices connected to low-voltage power systems – Requirements and test methods.

## 2. RATINGS ASSIGNED BY THE MANUFACTURER AND PROVED BY TESTS

Type	NNO 5/440	NNO 10/440
Continuous operating voltage	440 V ac	
Test classification	Class II	
Nominal discharge current for class II test	5 kA	10 kA
Voltage protection level	1500 V	1800V
Type of LV system	TN-system	
$I_{max}$	50 kA	
$U_{REF}$	255 V	

## 3. BASIC IDENTIFICATIONS DATA

Test objects	Surge Protective Devices	
Typ/ type	NNO 5/440; NNO 10/440	
Producent/Manufacturer	IzoElektro d.o.o. Limbuška cesta 2 SI-2341 Limbuš, EU	
Year of manufacture:	2014	
Drawings	Name	No.
	<ol style="list-style-type: none"> <li>LV Surge arrester NNO 10/440 – 0,5 m</li> <li>LV Surge arrester NNO 10/440 – 0,5 m+ Connector P1</li> <li>LV Surge arrester NNO 10/440 – 0,5 m + Connector P2 0,5 m</li> <li>LV Surge arrester NNO 10/440 – 0,5 m+ Connector P3</li> </ol>	<p>20 60 60</p> <p>20 60 63</p> <p>20 60 64</p> <p>20 60 65</p>

Condition of test objects before test :	New
Tests performed according to	EN 61643-11:2012





### 3. Testing for protection against direct contact

EN 61643-11:2012 cl. 8.3.1

IEC 61643-11:2011 cl. 8.3.1

Analysis of the SPD construction and test shown that:

- for the SPD type NNO with connector P1 and P2 can be assigned code IP 0X,
- for the SPD type NNO with connectors P3 can be assigned code IP 2X as long as the connectors are mounted tightly with the SPD.

### 4. IP code

EN 61643-11:2012 cl. 8.5.1

IEC 61643-11:2011 cl. 8.5.1

Analysis of the SPD construction and test shown that:

- for the SPD type NNO with connector P1 and P2 can be assigned code IP 00,
- for the SPD type NNO with connectors P3 can be assigned code IP 23 as long as the SPDs work in defined (normal) position and the connectors are mounted tightly with the SPD,
- for the SPD type NNO with connectors P3 can be assigned code IP 20, when the SPD works in another position than defined (normal).

### 5. Residual current

EN 61643-11:2012 cl. 8.3.2

IEC 61643-11:2011 cl. 8.3.2

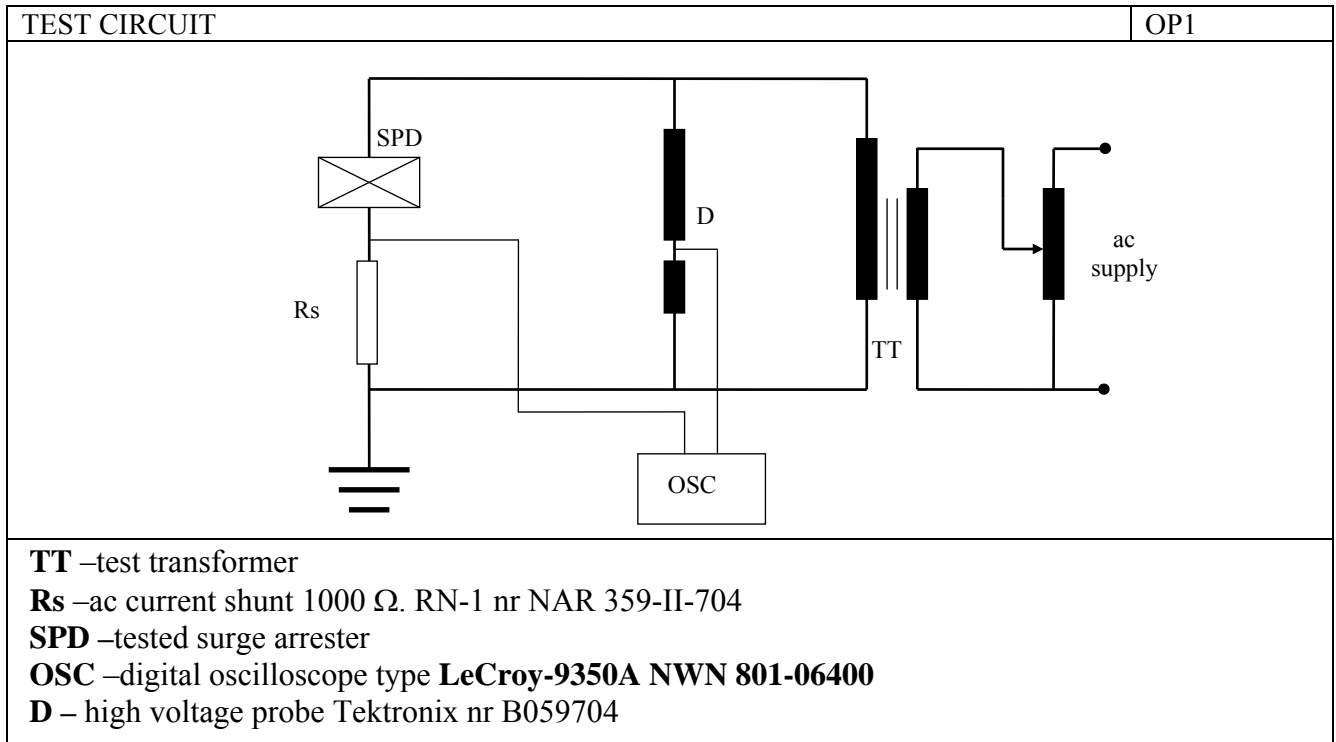

Test result

Sample	U <sub>REF</sub> [V]	I <sub>PE</sub> [μA]
NNO 5/440 no. 21	258	40,6
NNO 5/440 no. 22	259	53,1
NNO 5/440 no. 23	259	43,8
NNO 10/440 no. 24	260	46,9
NNO 10/440 no. 25	260	40,6
NNO 10/440 no. 26	260	43,8

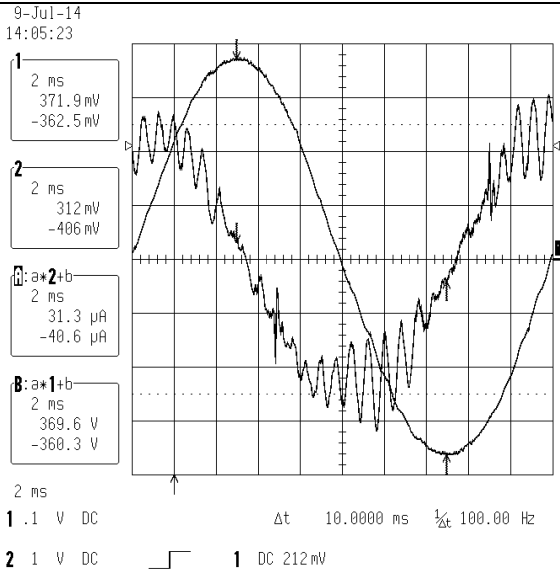

NNO 5/440 no. 21

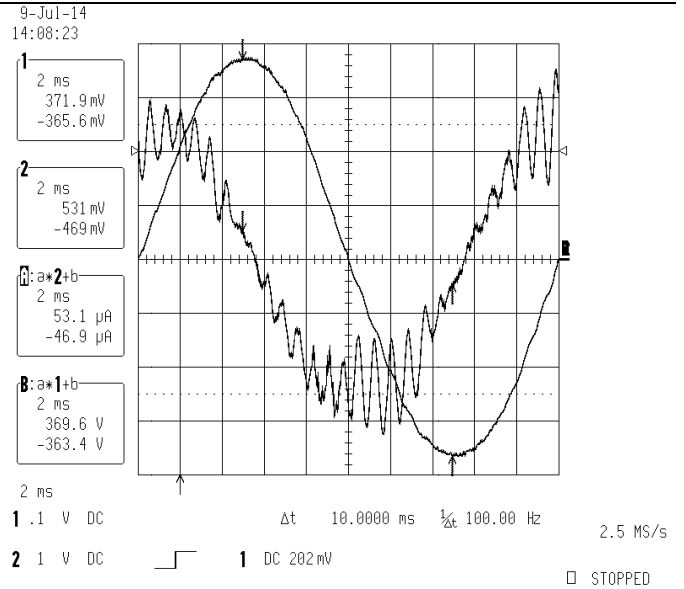

NNO 5/440 no. 22

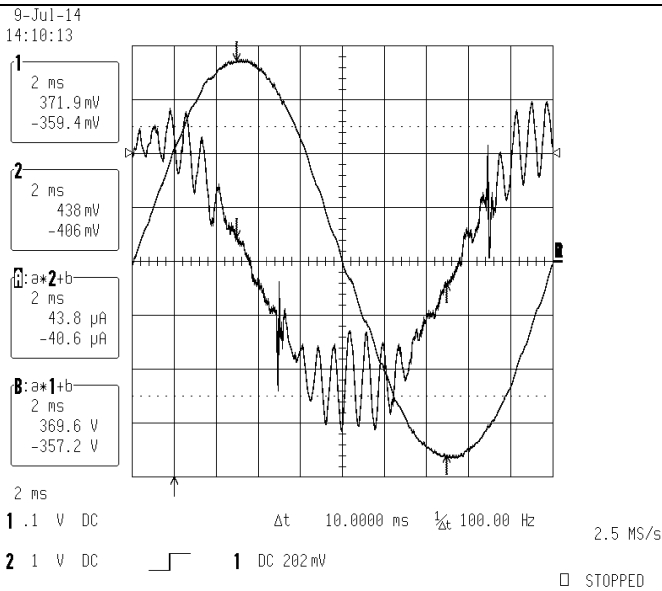

NNO 5/440 no. 23

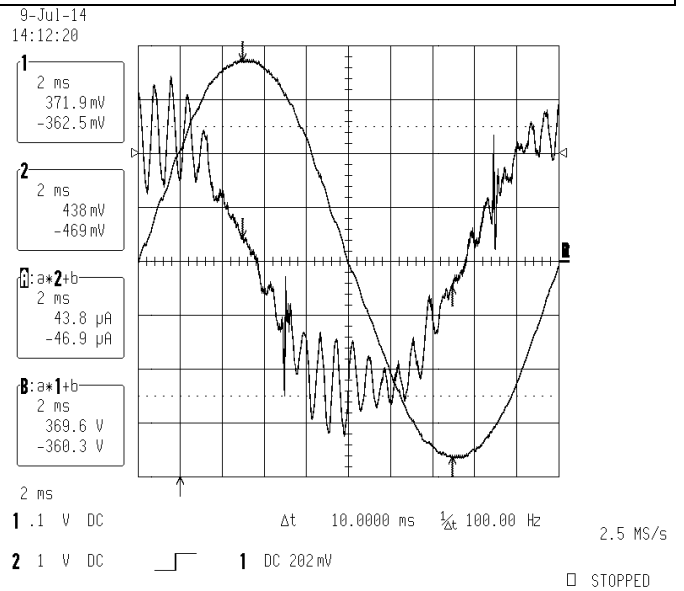

NNO 10/440 no. 24

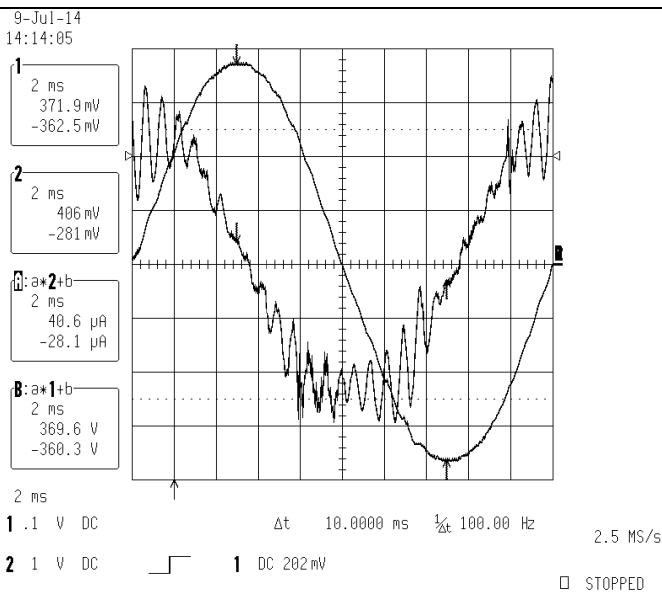

NNO 10/440 no. 25

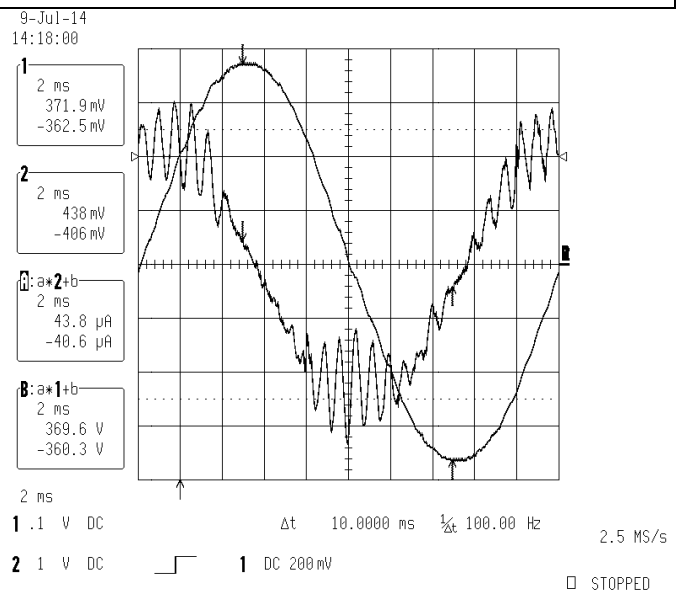

NNO 10/440 no. 26

Measurement of the residual current  $I_{PE}$  at  $U_{REF}$ .

## 6. Operating duty test for test class II

EN 61643-11:2012 cl. 8.3.4.3

IEC 61643-11:2011 cl. 8.3.4.3

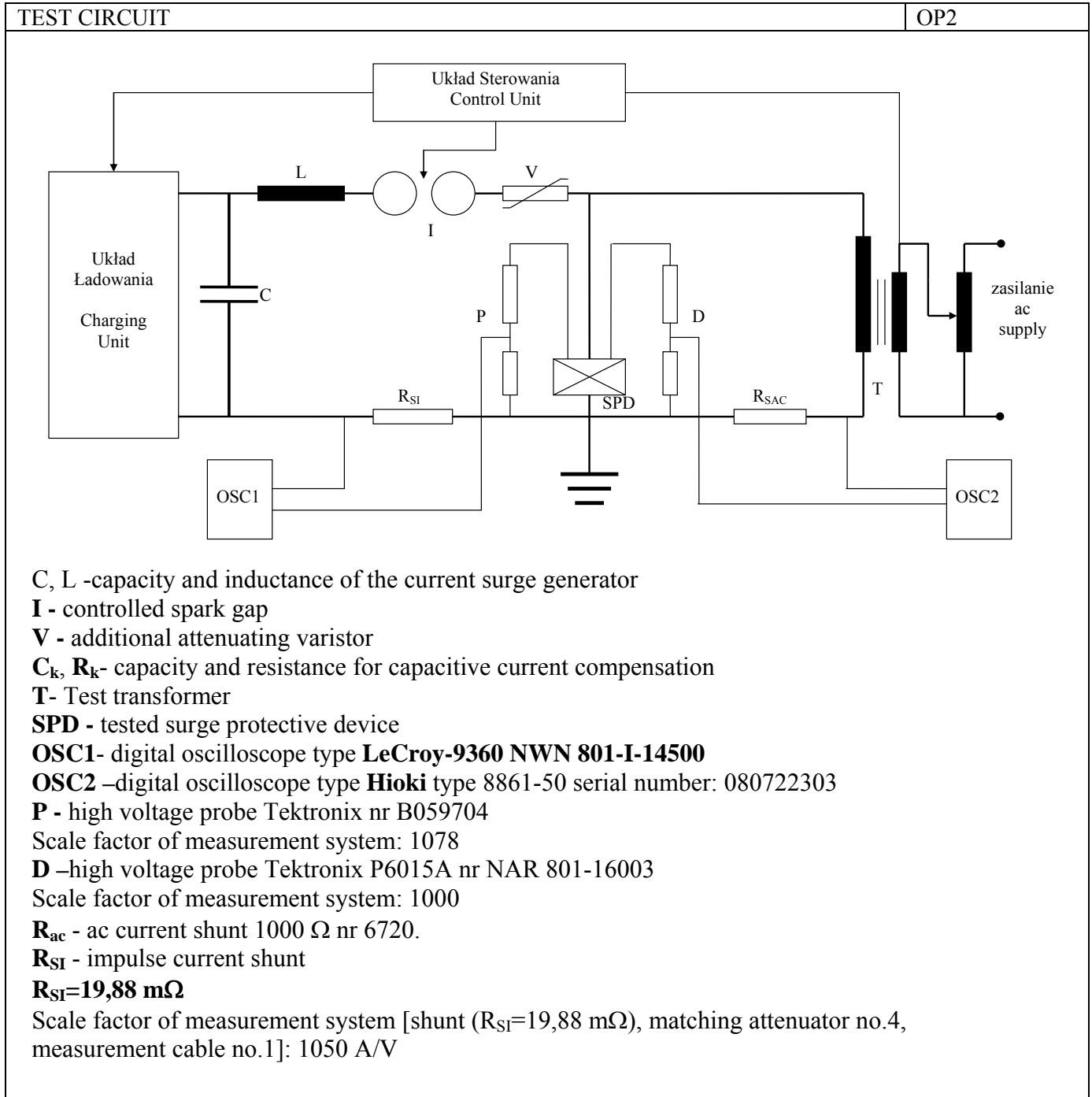

**NNO 5/440**

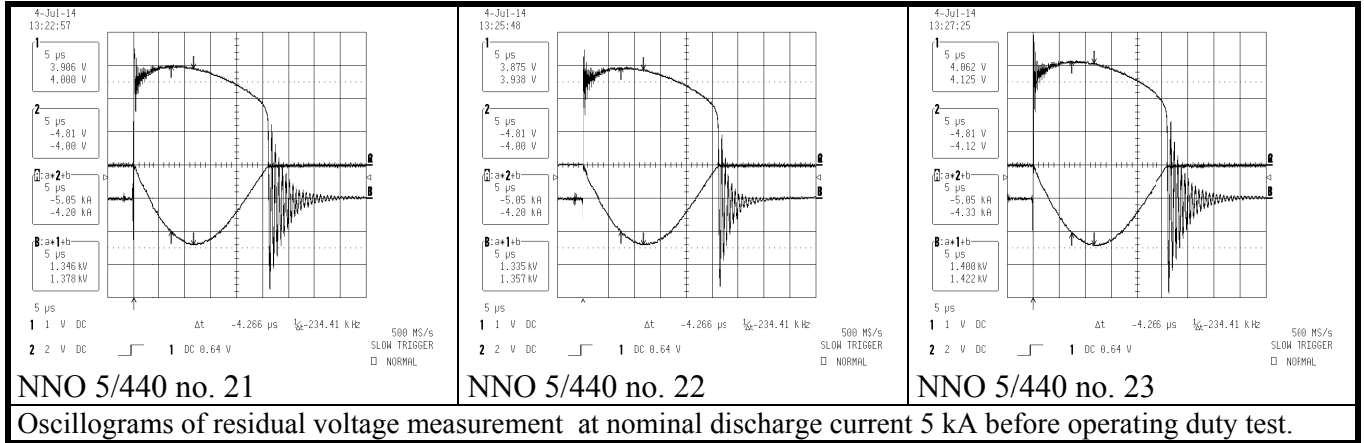

Oscillograms of residual voltage measurement at nominal discharge current 5 kA before operating duty test.

Synchronization angle		Sample NNO 5/440			
No of the impulse	[°el]		No. 21	No. 22	No. 23
1	0	[kA]	5,11	5,11	5,54
2	30	[kA]	5,08	5,11	5,47
3	60	[kA]	5,08	5,14	5,47
4	90	[kA]	5,02	5,11	5,37
5	120	[kA]	5,08	5,01	5,25
6	150	[kA]	4,85	5,21	5,31
7	180	[kA]	5,34	5,24	5,18
8	210	[kA]	5,21	5,21	5,05
9	240	[kA]	5,18	5,21	5,31
10	270	[kA]	5,31	5,24	5,34
11	300	[kA]	5,25	5,41	5,31
12	330	[kA]	5,21	5,34	5,44
13	0	[kA]	5,34	5,34	5,44
14	30	[kA]	5,28	5,37	5,44
15	60	[kA]	5,28	5,27	5,54

Sample		No. 21	No. 22	No. 23
U <sub>c</sub>	[V]	440	440	440
P <sub>1</sub>	[mW]	56,7	70,9	47,1
	osc	1752	1756	1762
P <sub>5</sub>	[mW]	51,6	65,0	44,1
	osc	1753	1757	1764
P <sub>10</sub>	[mW]	50,5	62,7	42,8
	osc	1754	1758	1766
P <sub>15</sub>	[mW]	49,7	62,0	42,0
	osc	1755	1759	1767

P<sub>x</sub> - the power losses after x minutes after 15-th impulse current

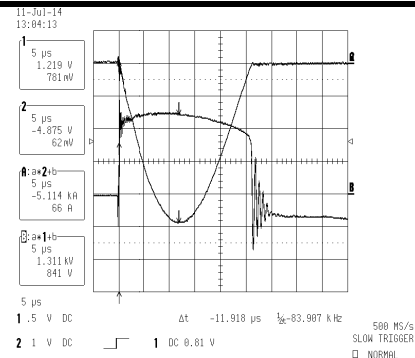

Impulse 1

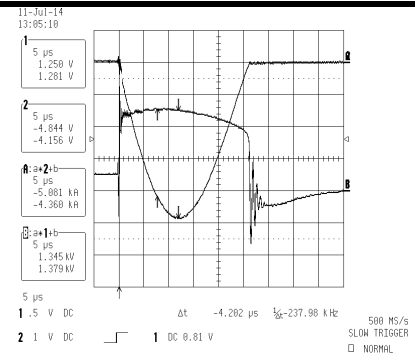

Impulse 2

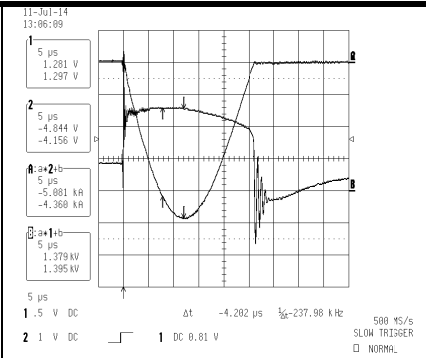

Impulse 3

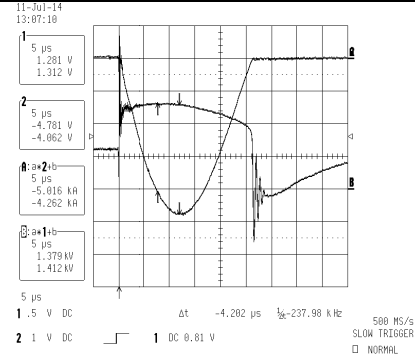

Impulse 4

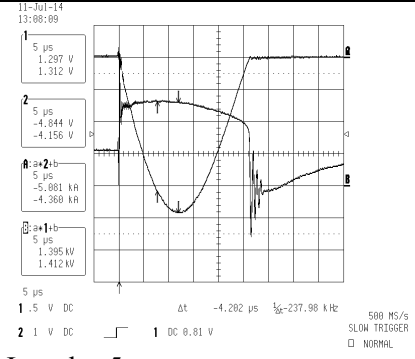

Impulse 5

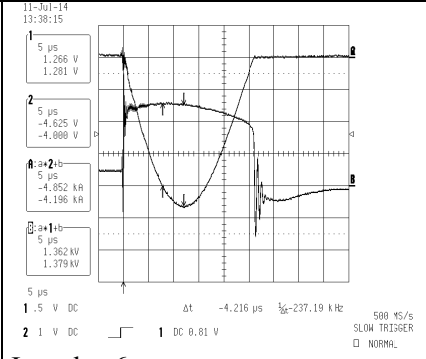

Impulse 6

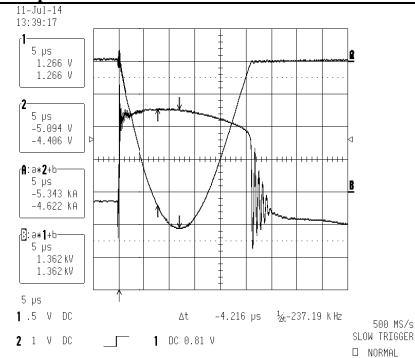

Impulse 7

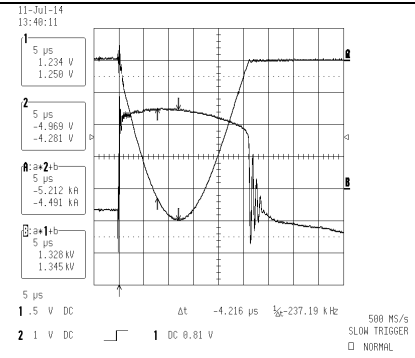

Impulse 8

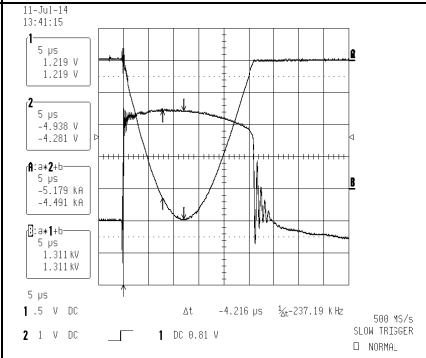

Impulse 9

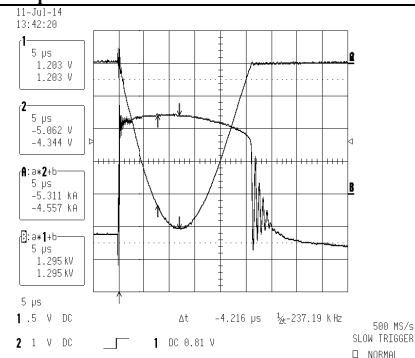

Impulse 10

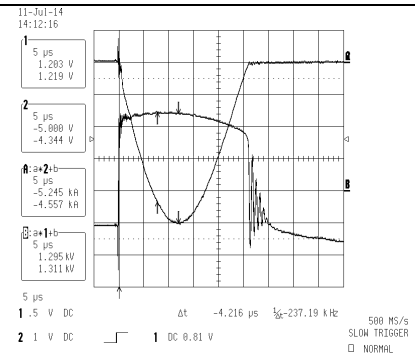

Impulse 11

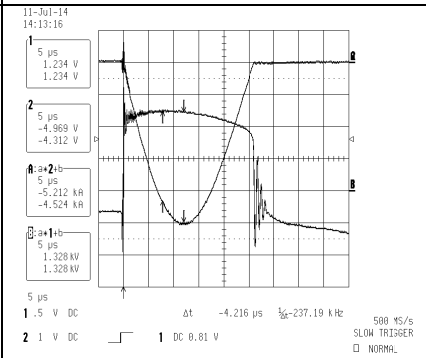

Impulse 12

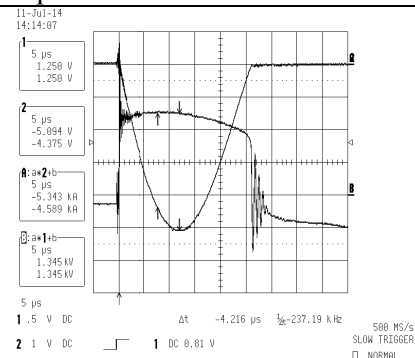

Impulse 13

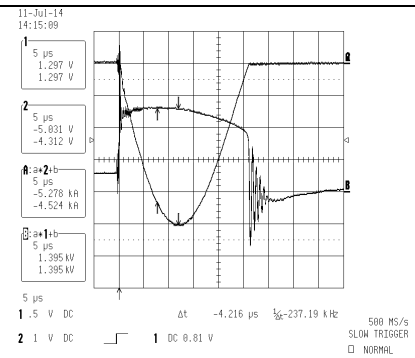

Impulse 14

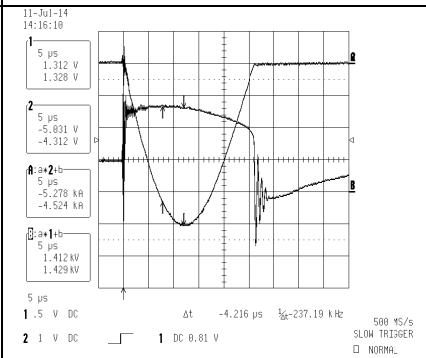

Impulse 15

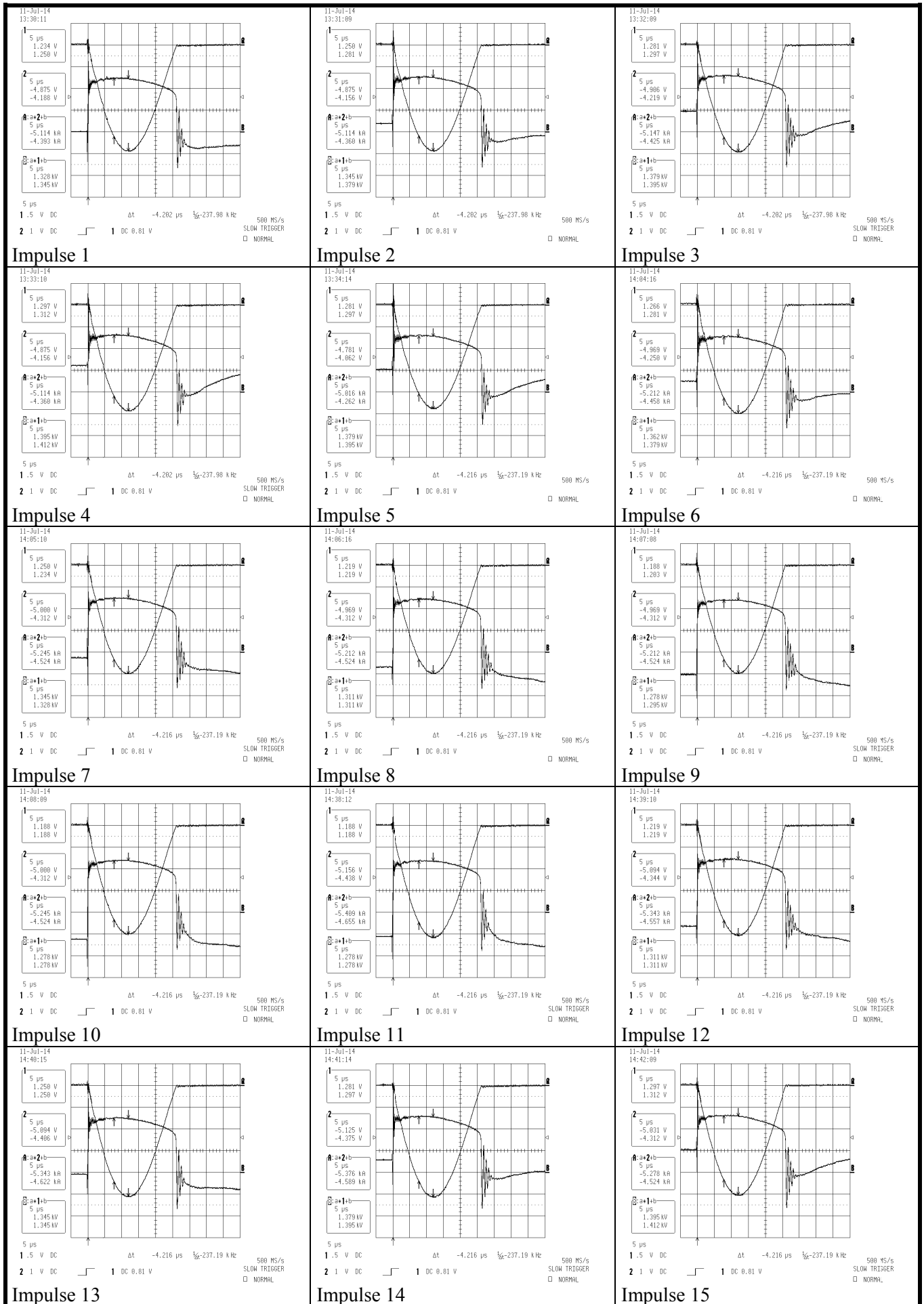

Oscillograms of voltage and impuls current during operating duty test of the SPD: NNO 5/440 no.22.

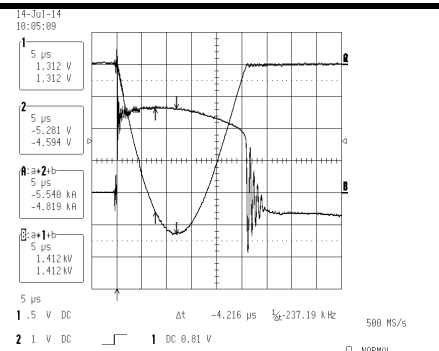

Impulse 1

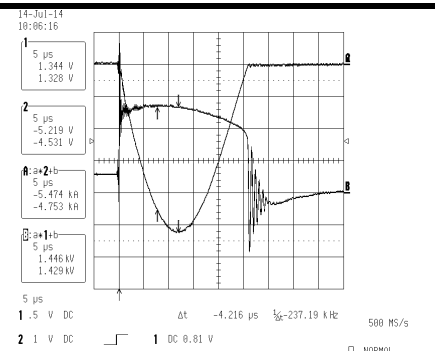

Impulse 2

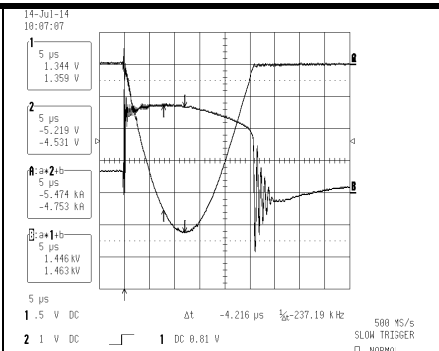

Impulse 3

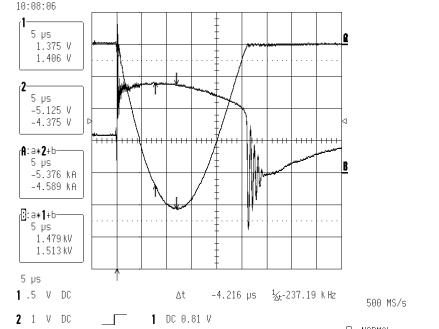

Impulse 4

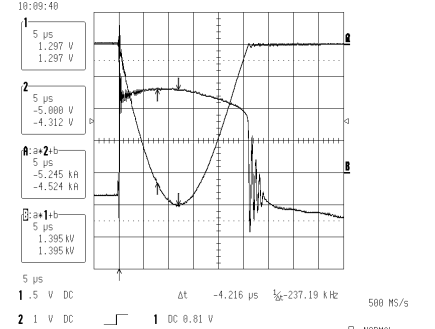

Impulse 5

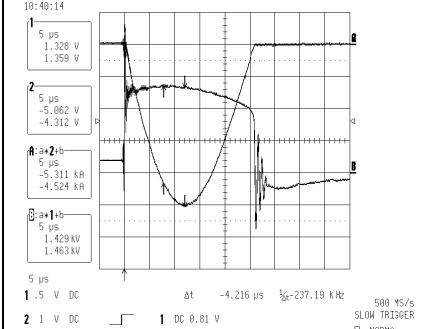

Impulse 6

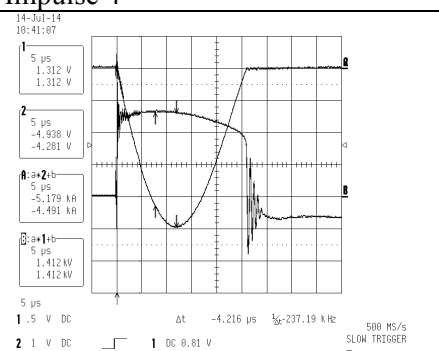

Impulse 7

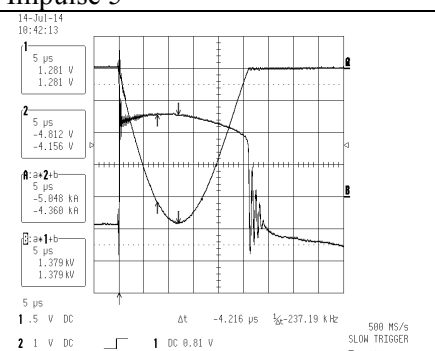

Impulse 8

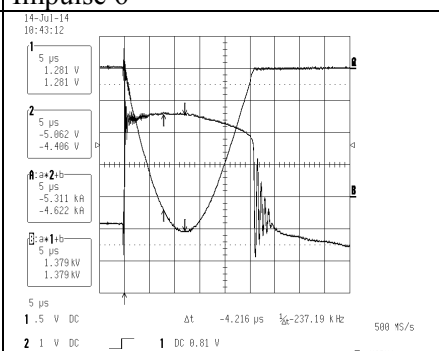

Impulse 9

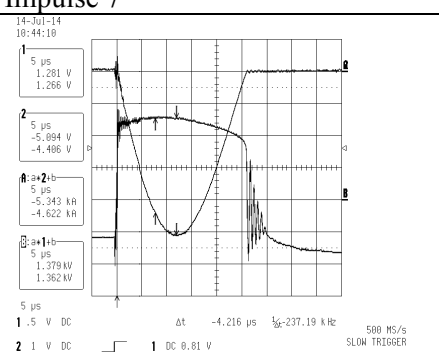

Impulse 10

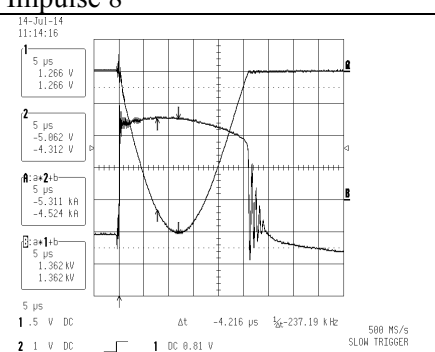

Impulse 11

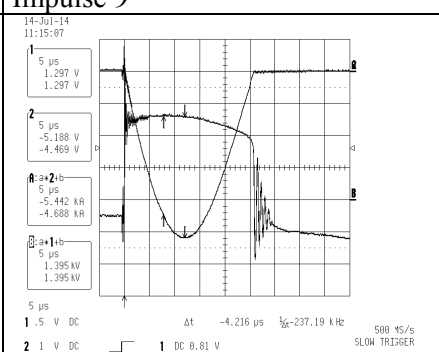

Impulse 12

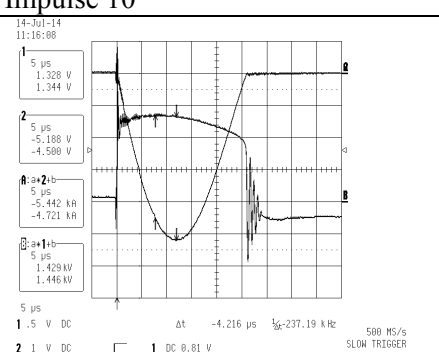

Impulse 13

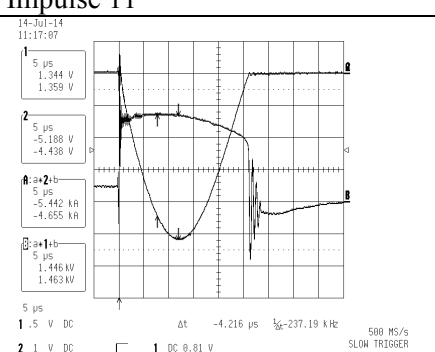

Impulse 14

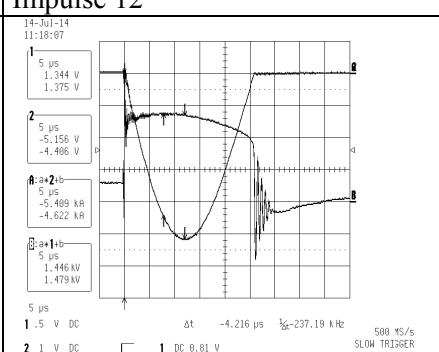

Impulse 15

Oscillograms of voltage and impuls current during operating duty test of the SPD: NNO 5/440 no.23.

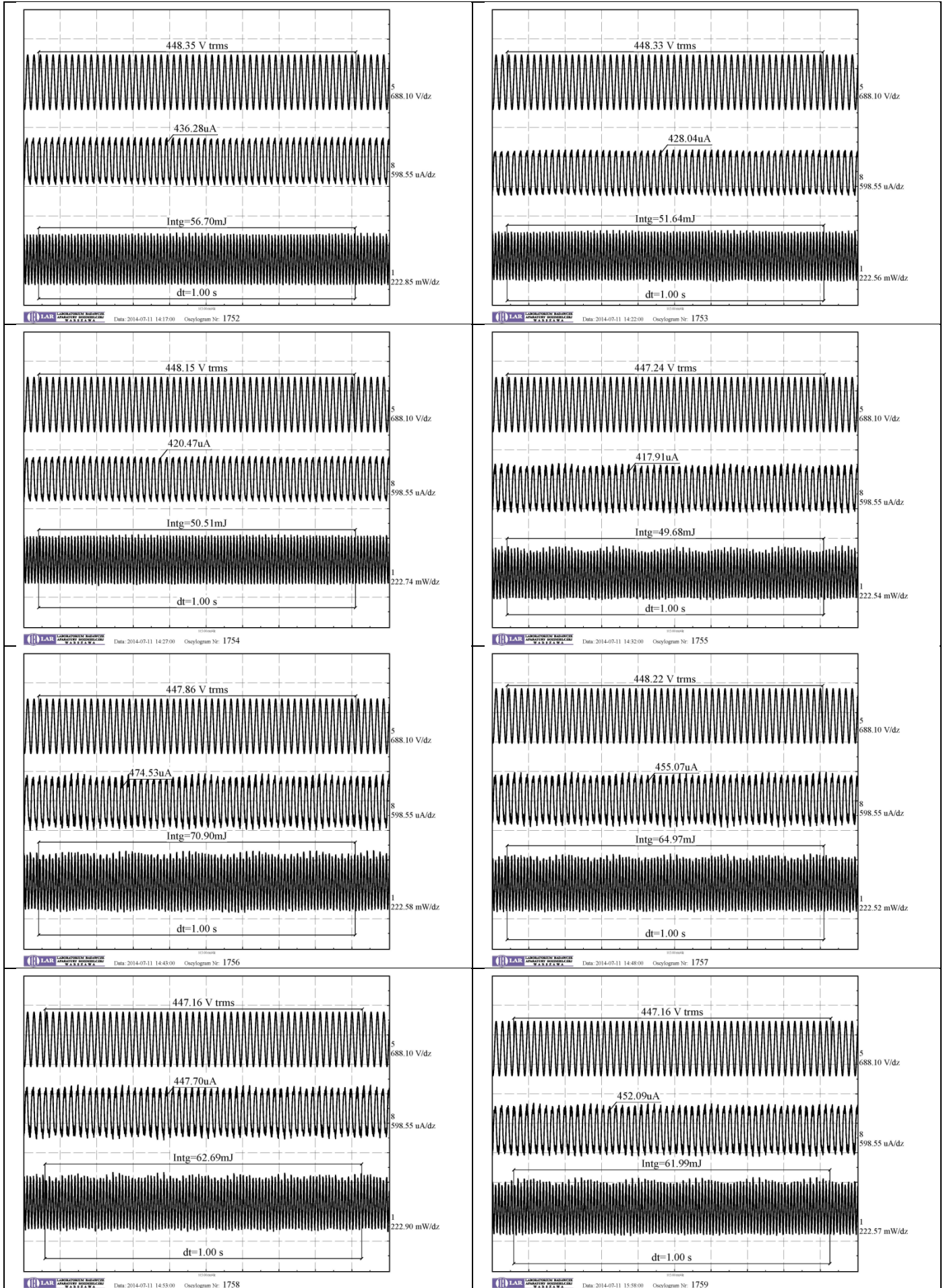

Measurement of watt losses measured at continuous operating voltage (440 V) in the operating duty test.



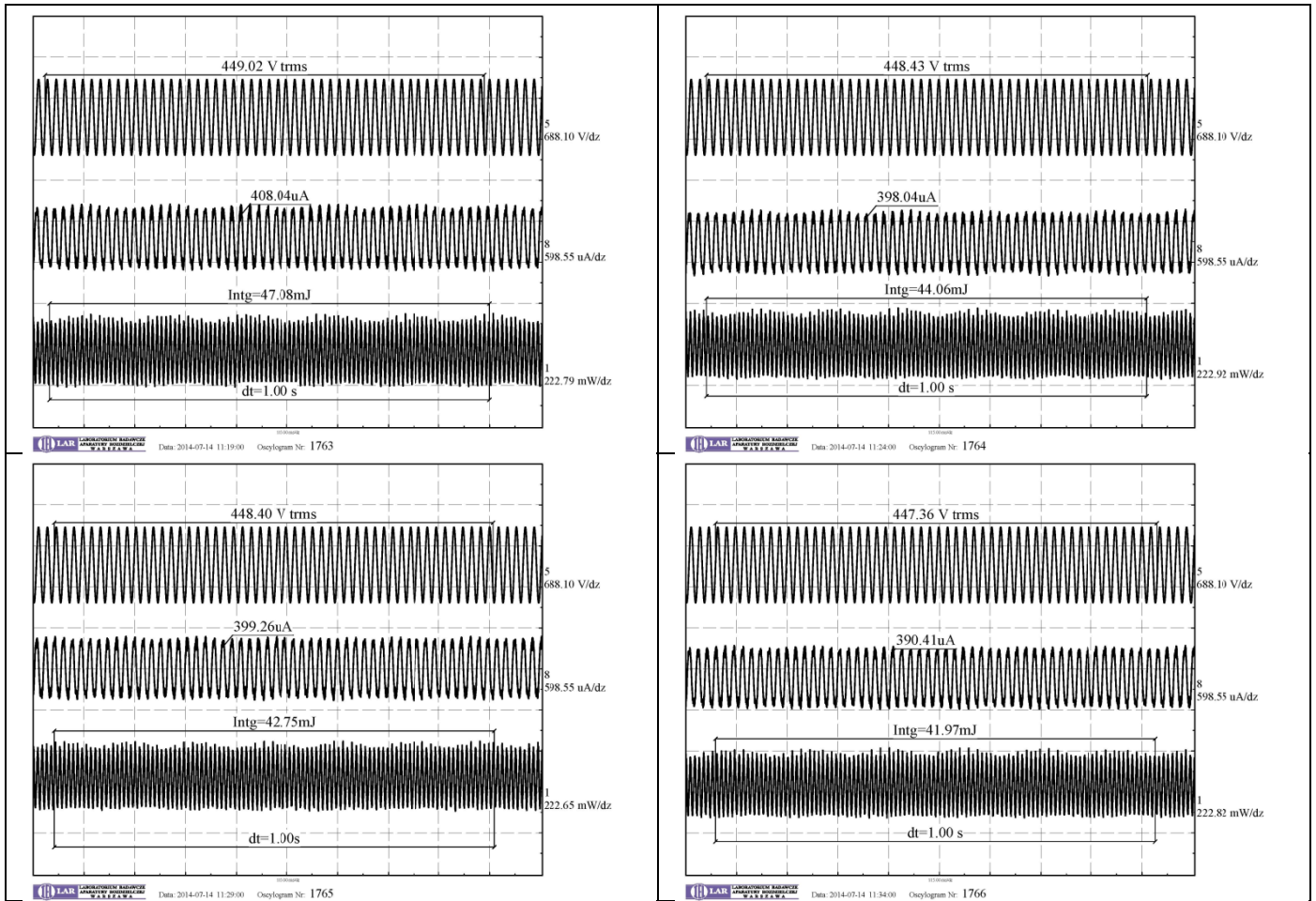

Measurement of watt losses measured at continuous operating voltage (440 V) in the operating duty test.

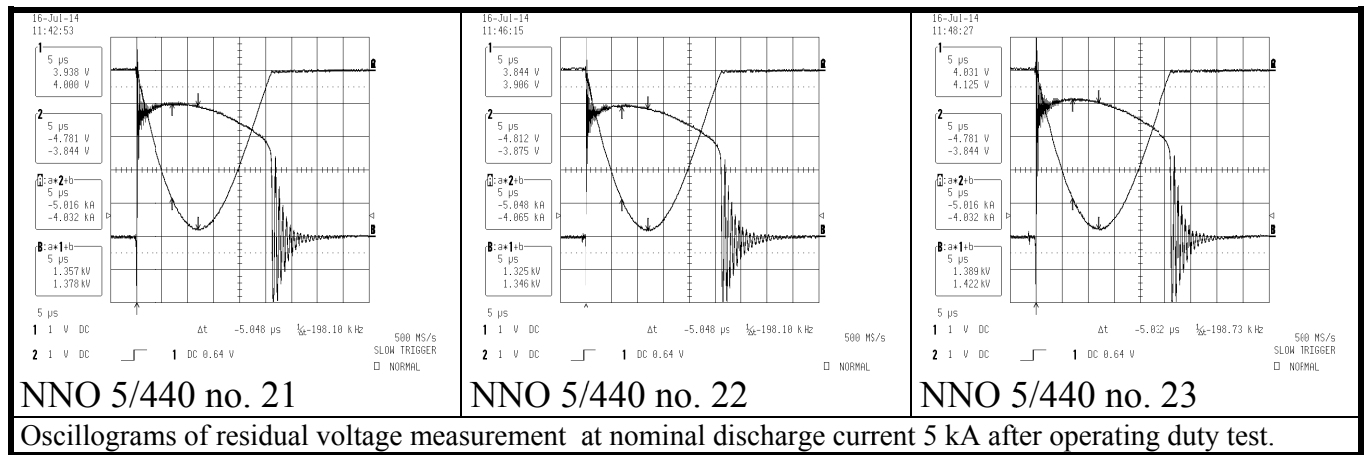

Oscillograms of residual voltage measurement at nominal discharge current 5 kA after operating duty test.

		NNO 5/440		
		no. 21	no. 22	no. 23
<b>Residual voltage</b>				
<b>before test</b>	[V]	1378	1357	1422
<b>after test</b>	[V]	1378	1346	1422
<b>Voltage protection level</b>	[V]	1500		

Residual current after operating duty test

Sample	$U_{REF}$ [V]	$I_{PE}$ [ $\mu A$ ]
NNO 5/440 no. 21	256	38
NNO 5/440 no. 22	256	38
NNO 5/440 no. 23	257	41



Pass criteria for operating duty test for NNO 5/440

	no. 21	no. 22	no. 23
A	Was applied	Was applied	Was applied
B			
C			
D			
E			
F			
G			
M			
Test result	Passed	Passed	Passed

## NNO 10/440

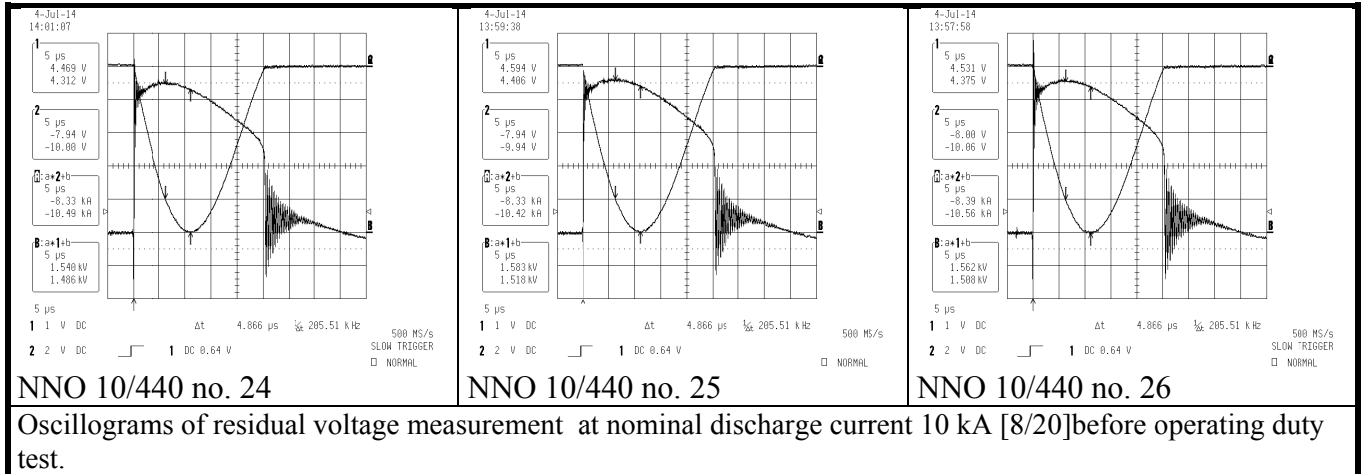

Oscillograms of residual voltage measurement at nominal discharge current 10 kA [8/20] before operating duty test.

Synchronization angle		Sample NNO 10/440			
No of the impulse	[°el]		No. 24	No. 25	No. 26
1	0	[kA]	10,49	10,36	10,36
2	30	[kA]	10,49	10,29	10,36
3	60	[kA]	10,49	10,42	10,23
4	90	[kA]	10,49	10,36	10,29
5	120	[kA]	10,33	10,36	10,36
6	150	[kA]	10,23	10,16	10,29
7	180	[kA]	10,29	10,16	10,29
8	210	[kA]	10,10	10,03	10,29
9	240	[kA]	10,16	10,23	10,29
10	270	[kA]	10,16	10,16	10,29
11	300	[kA]	10,36	10,29	10,36
12	330	[kA]	10,42	10,56	10,36
13	0	[kA]	10,42	10,42	10,42
14	30	[kA]	10,49	10,42	10,36
15	60	[kA]	10,49	10,29	10,29

Sample		No. 24	No. 25	No. 26
$U_c$	[V]	440	440	440
$P_1$	[mW]	65,8	57,4	52,6
	osc	1740	1744	1748
$P_5$	[mW]	54,1	49,2	43,6
	osc	1741	1745	1749
$P_{10}$	[mW]	51,7	46,8	41,6
	osc	1742	1746	1750
$P_{15}$	[mW]	51,0	45,7	41,0
	osc	1743	1747	1751

$P_x$  - the power losses after x minutes after 15-th impulse current

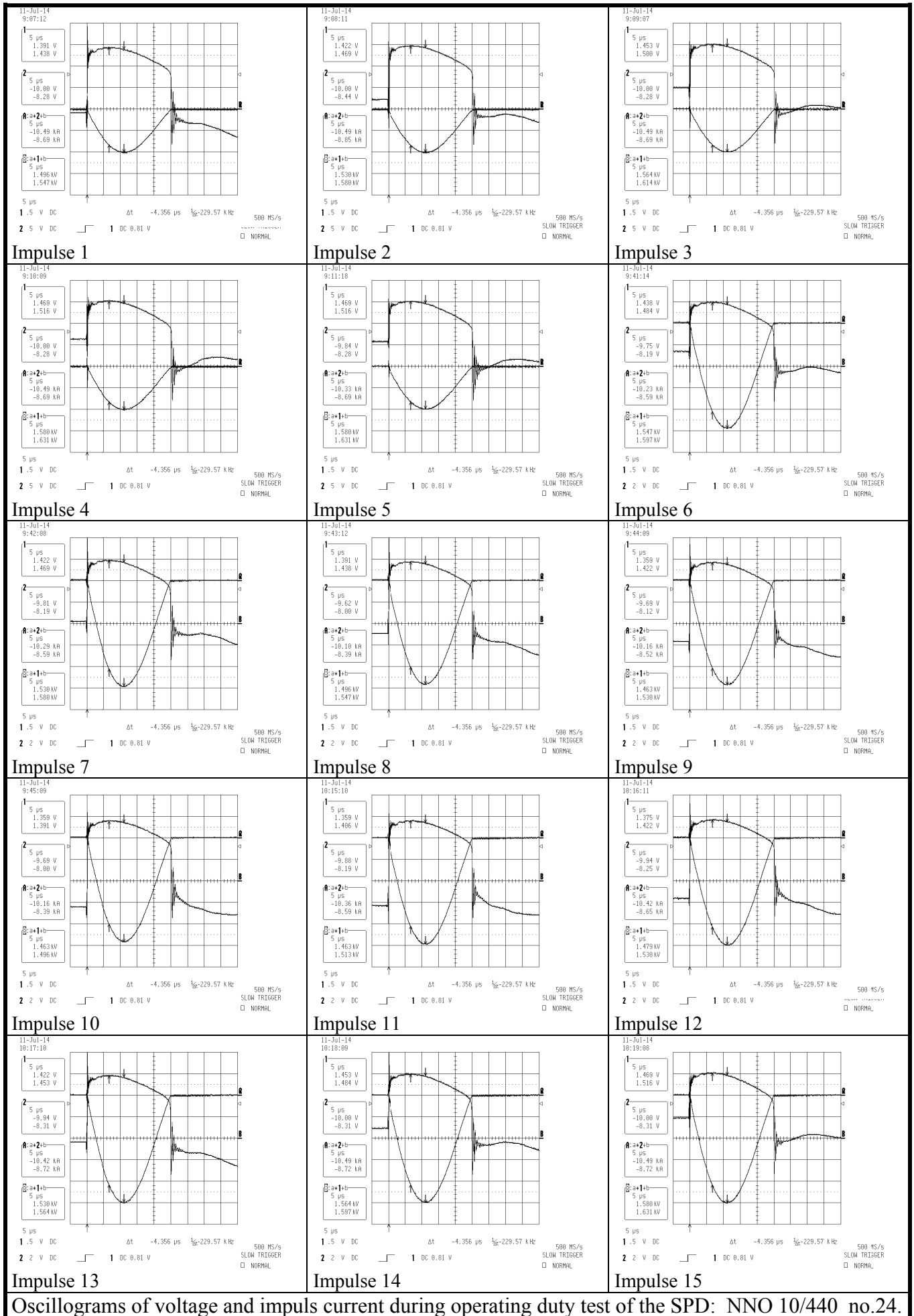

Oscillograms of voltage and impuls current during operating duty test of the SPD: NNO 10/440 no.24.

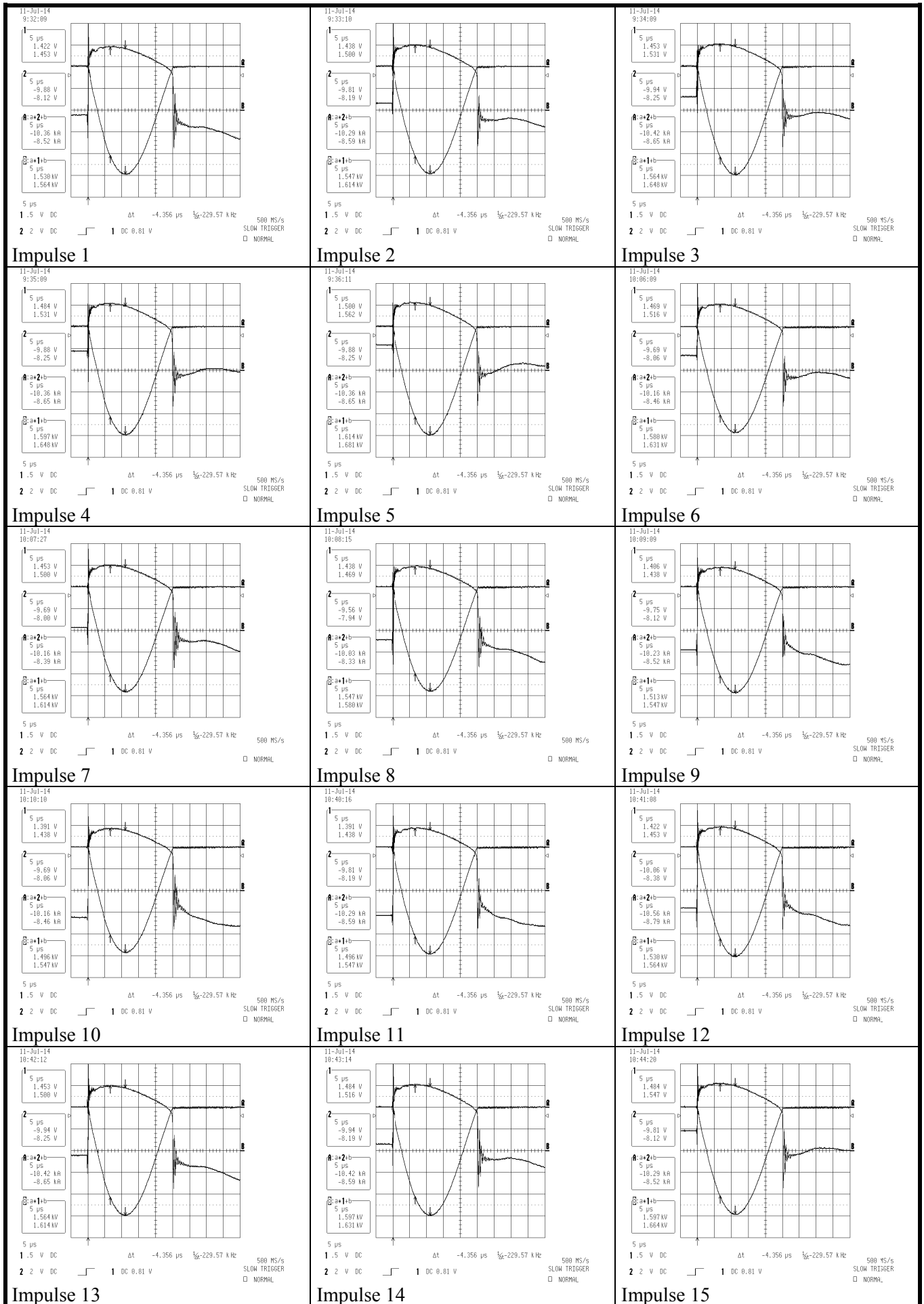

Oscillograms of voltage and impuls current during operating duty test of the SPD: NNO 10/440 no.25.

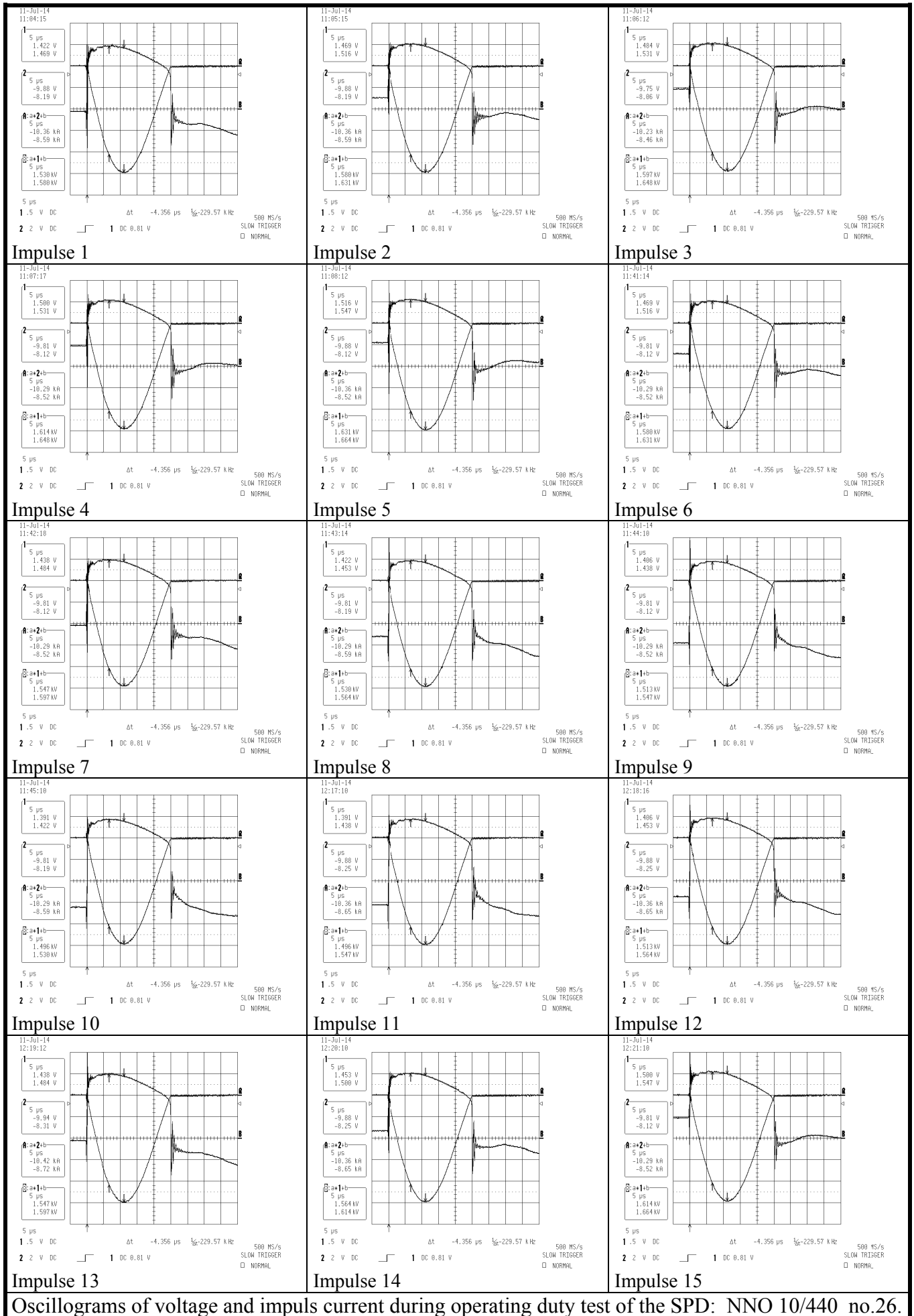

Oscillograms of voltage and impuls current during operating duty test of the SPD: NNO 10/440 no.26.

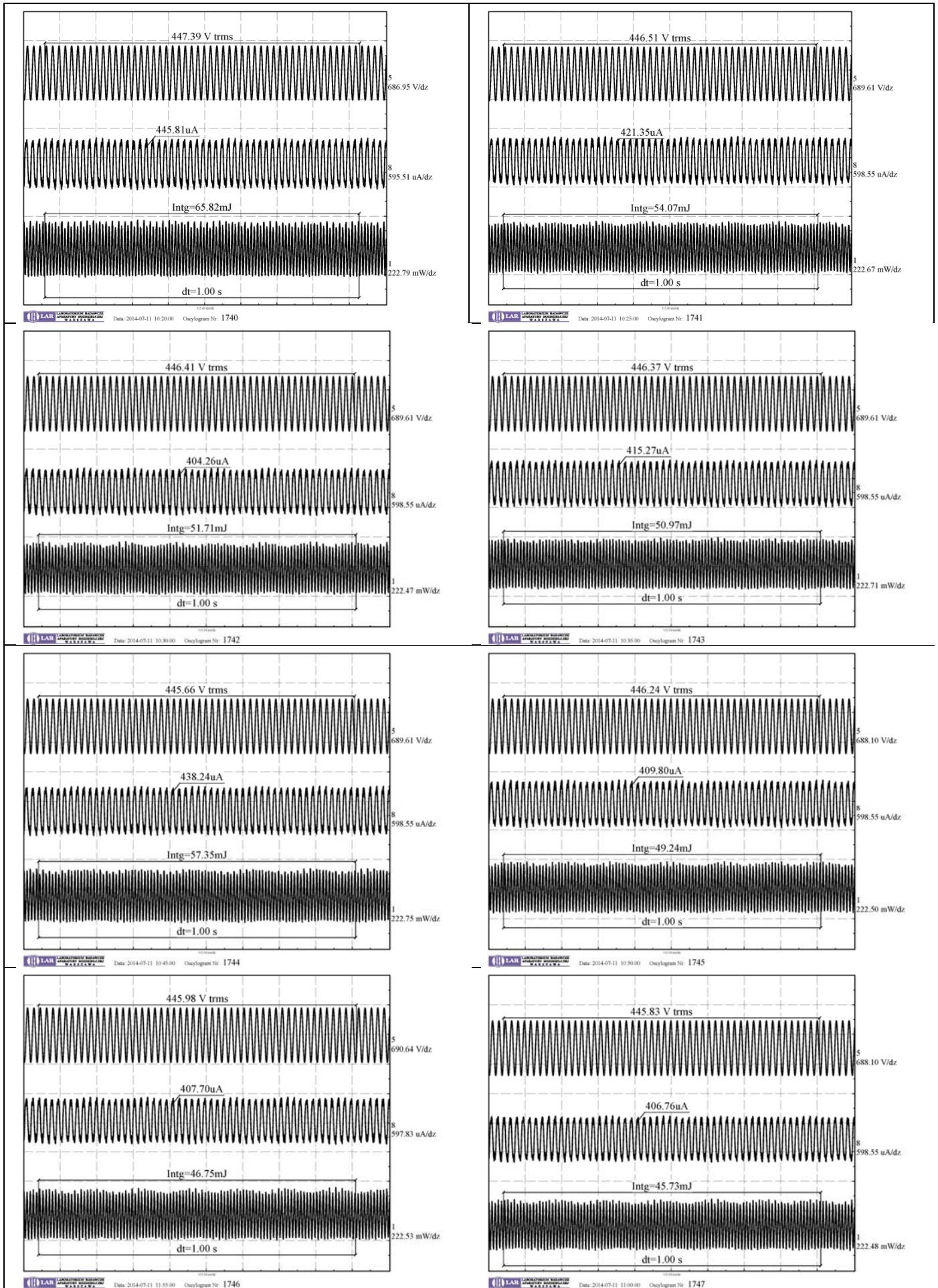

Measurement of watt losses measured at continuous operating voltage (440 V) in the operating duty test.

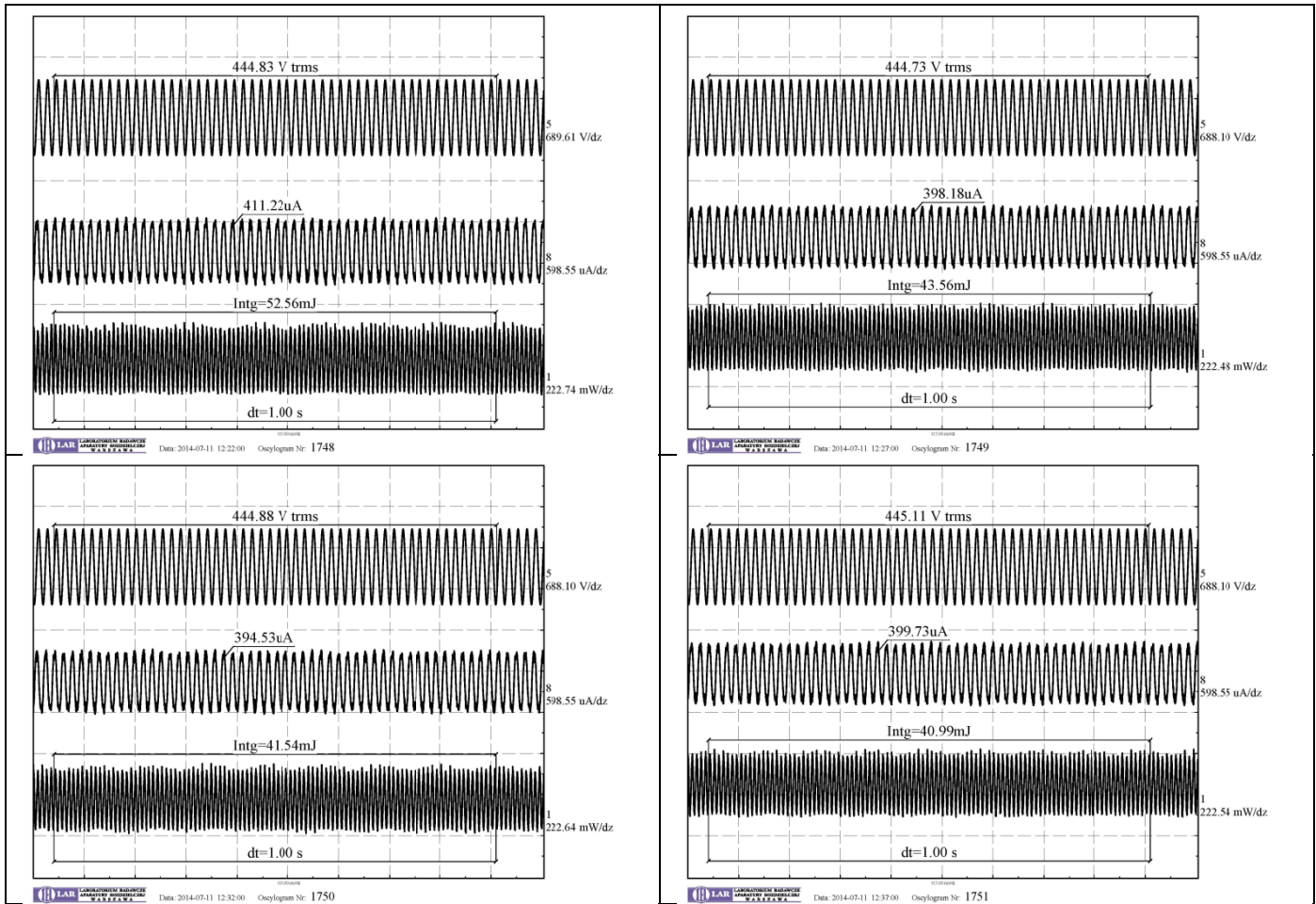

Measurement of watt losses measured at continuous operating voltage (440 V) in the operating duty test.

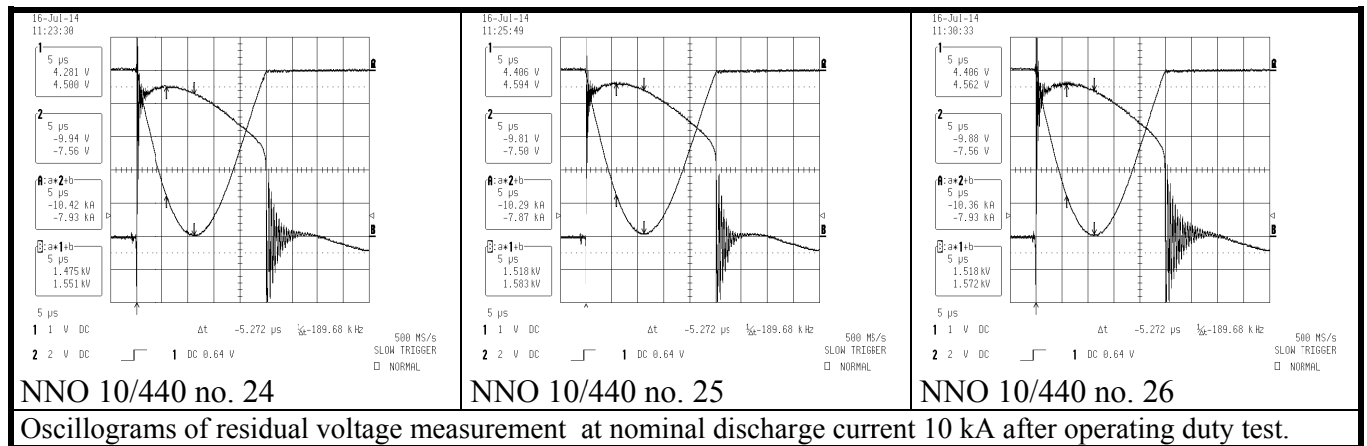

NNO 10/440 no. 24

NNO 10/440 no. 25

NNO 10/440 no. 26

Oscillograms of residual voltage measurement at nominal discharge current 10 kA after operating duty test.

Residual voltage		NNO 10/440		
		no. 24	no. 25	no. 26
before test	[V]	1540	1583	1562
after test	[V]	1551	1583	1572
Voltage protection level	[V]	1800		

Residual current after operating duty test

Sample	$U_{REF}$ [V]	$I_{PE}$ [ $\mu$ A]
NNO 10/440 no. 24	257	40,6
NNO 10/440 no. 25	258	38
NNO 10/440 no. 26	257	38



Pass criteria for operating duty test for NNO 10/440

	no. 24	no. 25	no. 26
A	Was applied	Was applied	Was applied
B			
C			
D			
E			
F			
G			
M			
Test result	Passed	Passed	Passed

## 7. Thermal stability

EN 61643-11:2012 cl. 8.3.5.2

IEC 61643-11:2011 cl. 8.3.5.2

TEST CIRCUIT

OP3

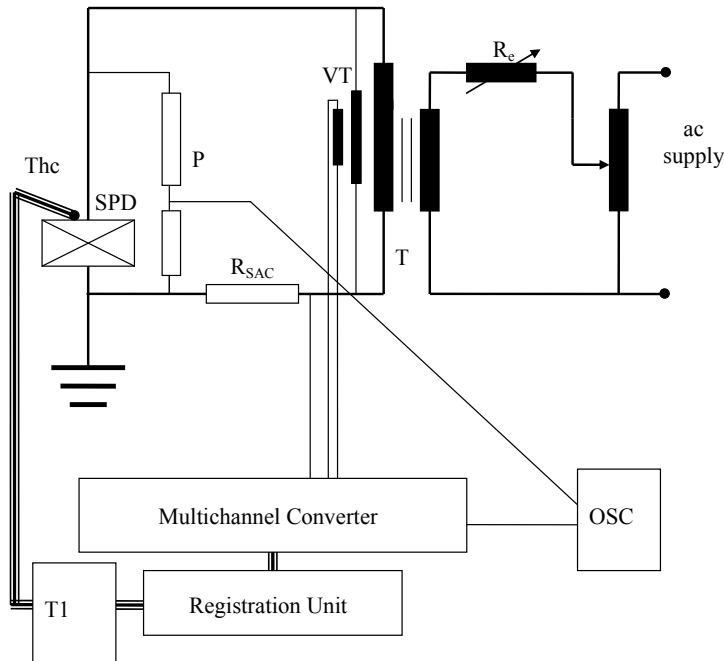

**OSC** - digital oscilloscope type **LeCroy-9350A NWN 801-06400**

**VT** –voltage transformer

**T**- Test transformer

**SPD** –tested surge protective device

**The** –thermocouple type J no.1

**T1** – temperature meter **EMT200** no.1

**RSAC** –ac current shunt 100  $\Omega$  nr 184.

**Re** –Adjustable inductive reactor limiting the test current

	NNO 10/440		
	No. 14	No. 15	No. 16
Test currents [mA]	2; 4; 6; 8; 10; 12; 14; 16; 18; 20; 22	12; 14; 16; 18; 20; 22; 24	12; 14; 16; 18; 20; 22; 24
Max. temperature [°C]	134,1	<b>146,4</b>	141,1
Time to disconnector operation [min]	217	127	137

Pass criteria for thermal stability test for NNO 10/440

	no. 14	no. 15	no. 16
C	Was applied	Was applied	Was applied
H			
I			
J			
M			
O			
Test result	Passed	Passed	Passed



The red arrow shows the point of temperature measurement, which has been determined in the initial test as the hottest spot of the housing of the SPD type NNO 10/440.

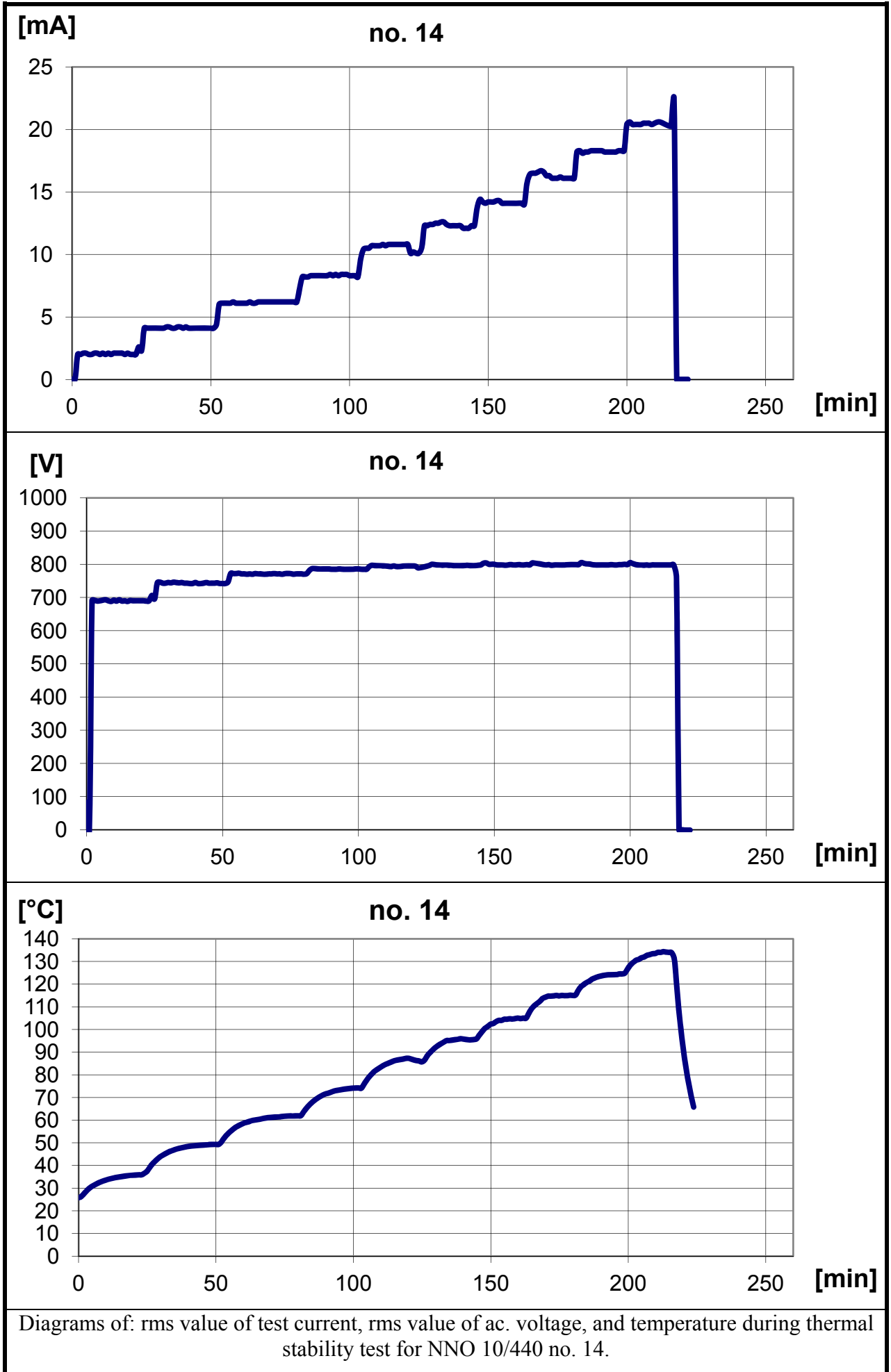

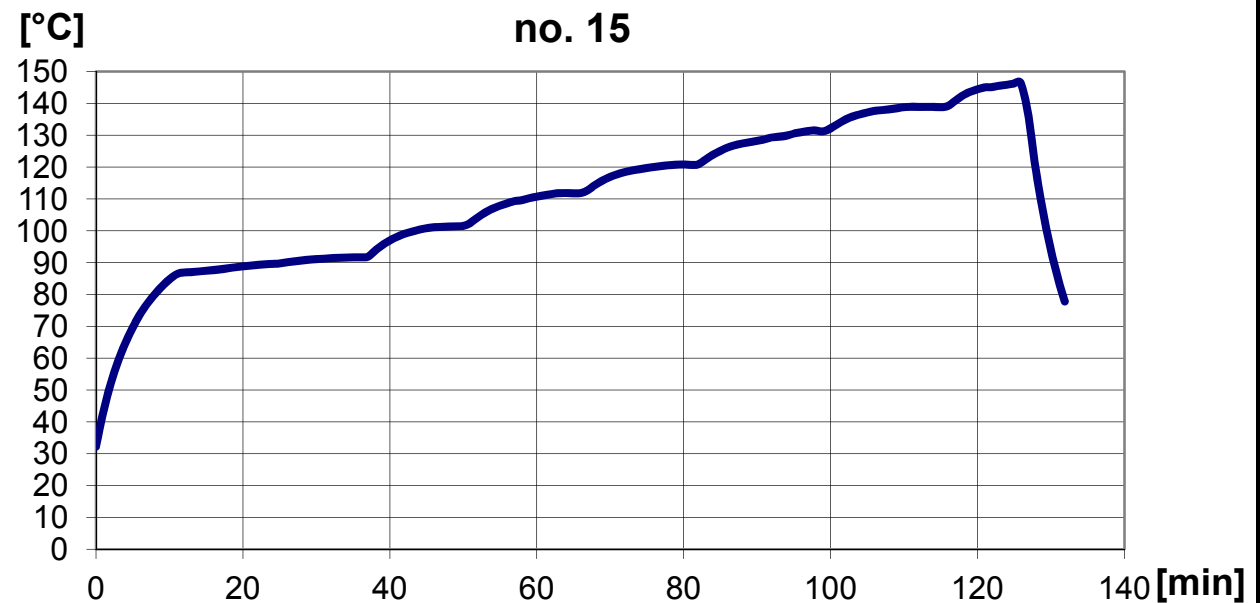
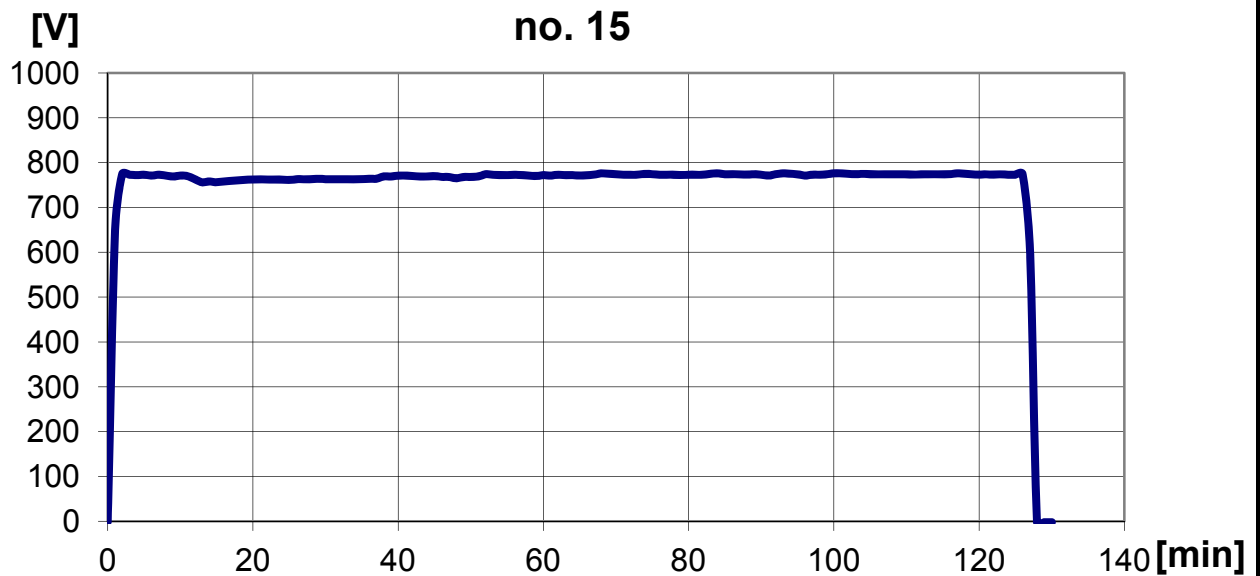
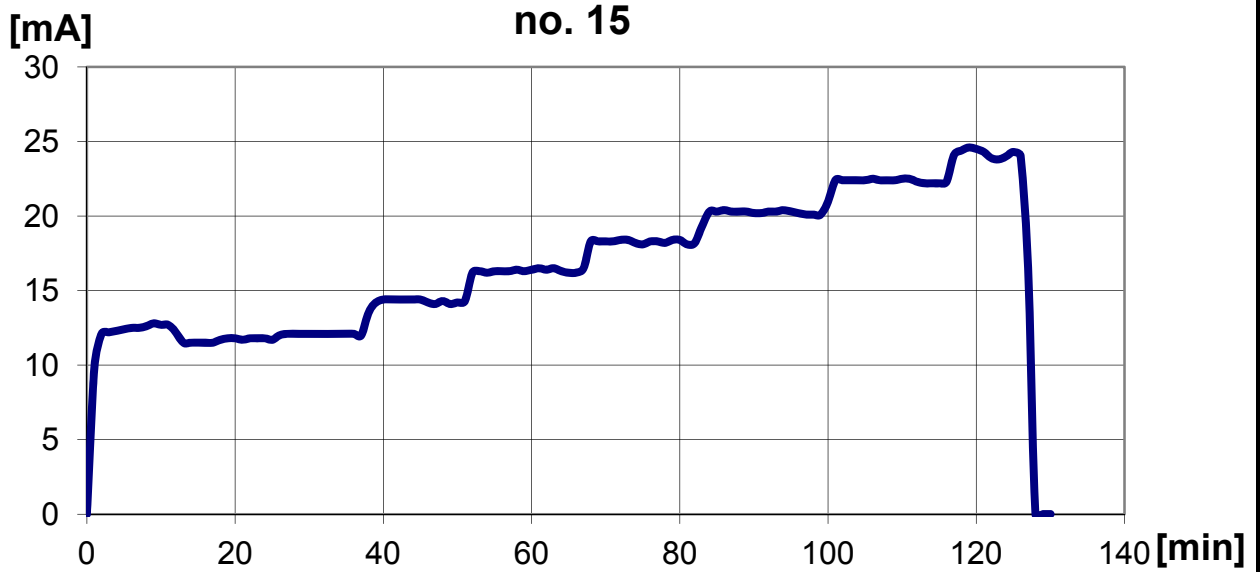

Diagrams of: rms value of test current, rms value of ac. voltage, and temperature during thermal stability test for NNO 10/440 no. 15.

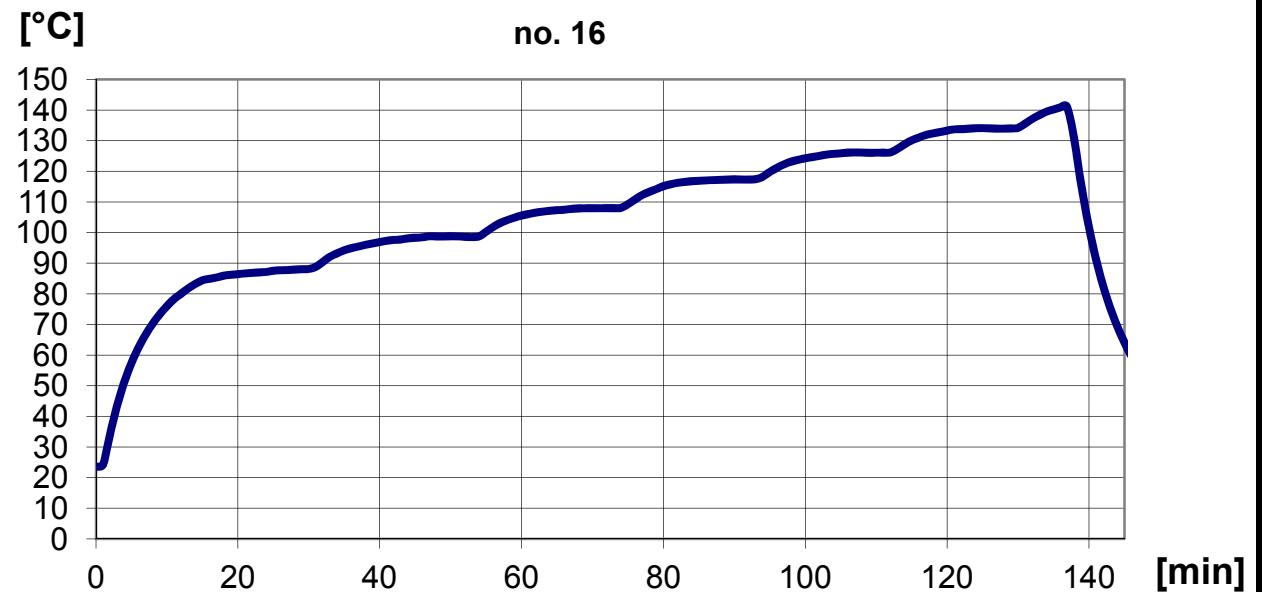
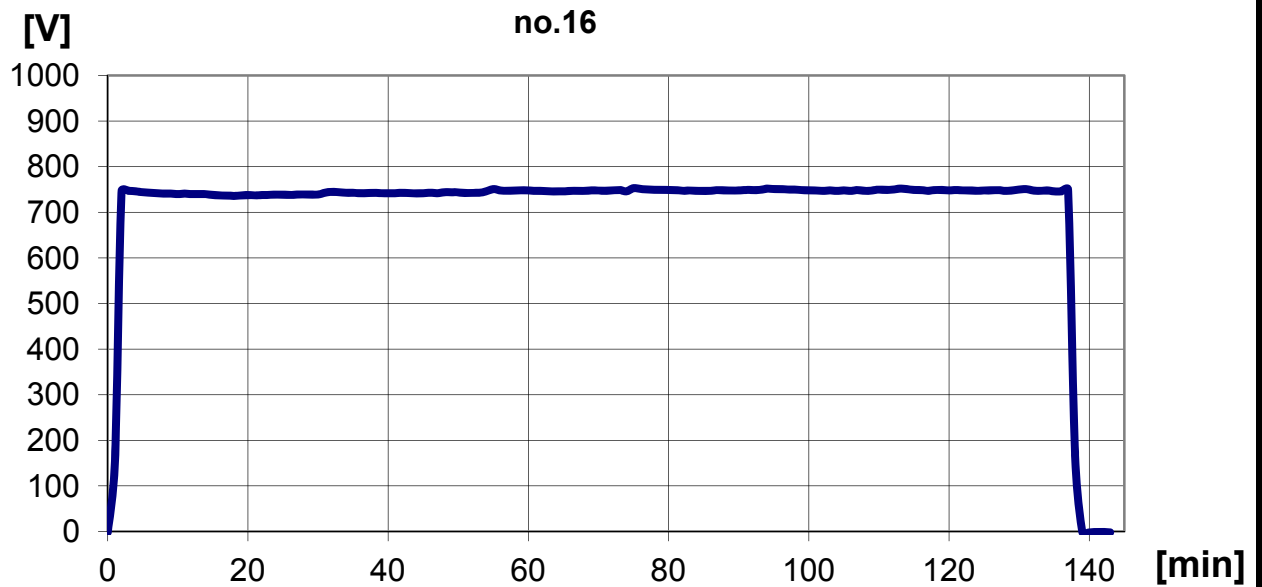
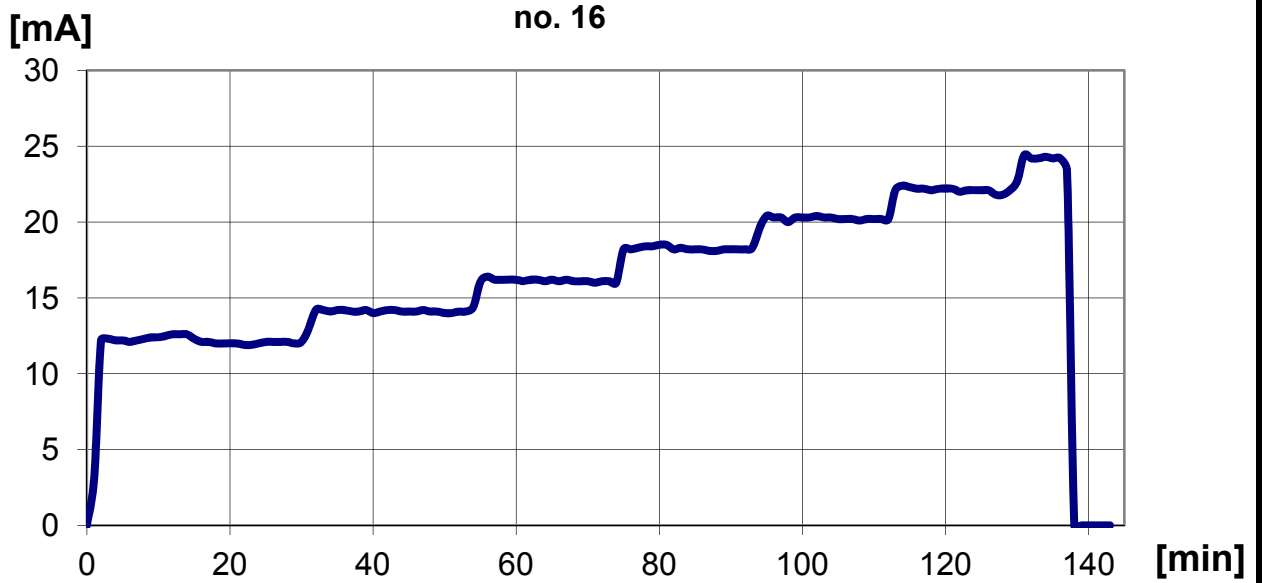

Diagrams of: rms value of test current, rms value of ac. voltage, and temperature during thermal stability test for NNO 10/440 no. 16.



View of NNO 10/440 no. 14 after operating.



View of NNO 10/440 no. 15 after operating.



View of NNO 10/440 no. 16 after operating.

## **8. Air clearances and creepage distances**

EN 61643-11:2012 cl. 8.4.3

IEC 61643-11:2011 cl. 8.4.3

The test was carried out in Testing and Calibrating Laboratory (NBW) in the Electrotechnical Institute and was written in test report: 400/NZL/NBW/2014/O

## **9. Ball pressure test**

EN 61643-11:2012 cl. 8.5.3

IEC 61643-11:2011 cl. 8.5.3

The test was carried out in Testing and Calibrating Laboratory (NBW) in the Electrotechnical Institute and was written in test report: 400/NZL/NBW/2014/O.

## **10. Resistance to abnormal heat and fire**

EN 61643-11:2012 cl. 8.5.4

IEC 61643-11:2011 cl. 8.5.4

The test was carried out in Testing and Calibrating Laboratory (NBW) in the Electrotechnical Institute and was written in test report: 178/NZL/NBW/2014/O.

## **11. Tracking resistance**

EN 61643-11:2012 cl. 8.5.5

IEC 61643-11:2011 cl. 8.5.5

The test was carried out in Testing and Calibrating Laboratory (NBW) in the Electrotechnical Institute and was written in test report: 400/NZL/NBW/2014/O.

## 12. Residual voltage

EN 61643-11:2012 cl. 8.3.3.1

IEC 61643-11:2011 cl. 8.3.3.1

TEST CIRCUIT	OP4
<p><b>C, L</b> - capacity and inductance of the universal current surge generator  <b>I</b> - controlled spark gap  <b>D</b> - impulse voltage divider DNU30  Scale factor of measurement system [divider no.2 (<math>R_D=1505,4 \Omega</math>), matching attenuator no. 8, measure cable no.2]: 344,61  <b>SPD</b> - tested surge arrester  <b>OSC</b>- digital oscilloscope type <b>LeCroy-9350A NWN 801-06400</b>  <b>R<sub>st</sub></b> - impulse current shunt  <b>R<sub>st</sub>=19,88 mΩ</b>  Scale factor of measurement system [shunt (<math>R_{st}=19,88 \text{ m}\Omega</math>), matching attenuator no. 4, measurement cable no.1]: 1050 A/V for currents: 5 kA, 10 kA  <b>R<sub>st</sub>=4,163 mΩ</b>  Scale factor of measurement system [shunt (<math>R_{st}=4,163 \text{ m}\Omega</math>), matching attenuator no. 4, measurement cable no.1]: 5012 A/V for currents: 40 kA and 50 kA</p>	

NNO 10/440 No. 27			NNO 10/440 No. 28			NNO 10/440 No. 29		
$I_{8/20}$ [kA]	$U_{RES}$ [V]	Energy [J]	$I_{8/20}$ [kA]	$U_{RES}$ [V]	Energy [J]	$I_{8/20}$ [kA]	$U_{RES}$ [V]	Energy [J]
Positive polarity								
5,11	1357		5,11	1368		5,05	1389	
10,56	1572		10,49	1583		10,49	1605	
41,98	2412	1239	40,42	2434	1201	40,10	2412	1213
50,44	2649	1607	50,13	2692	1600	49,82	2692	1611
Negative polarity								
5,05	1335		5,11	1357		5,05	1357	
10,10	1529		10,03	1551		10,23	1583	



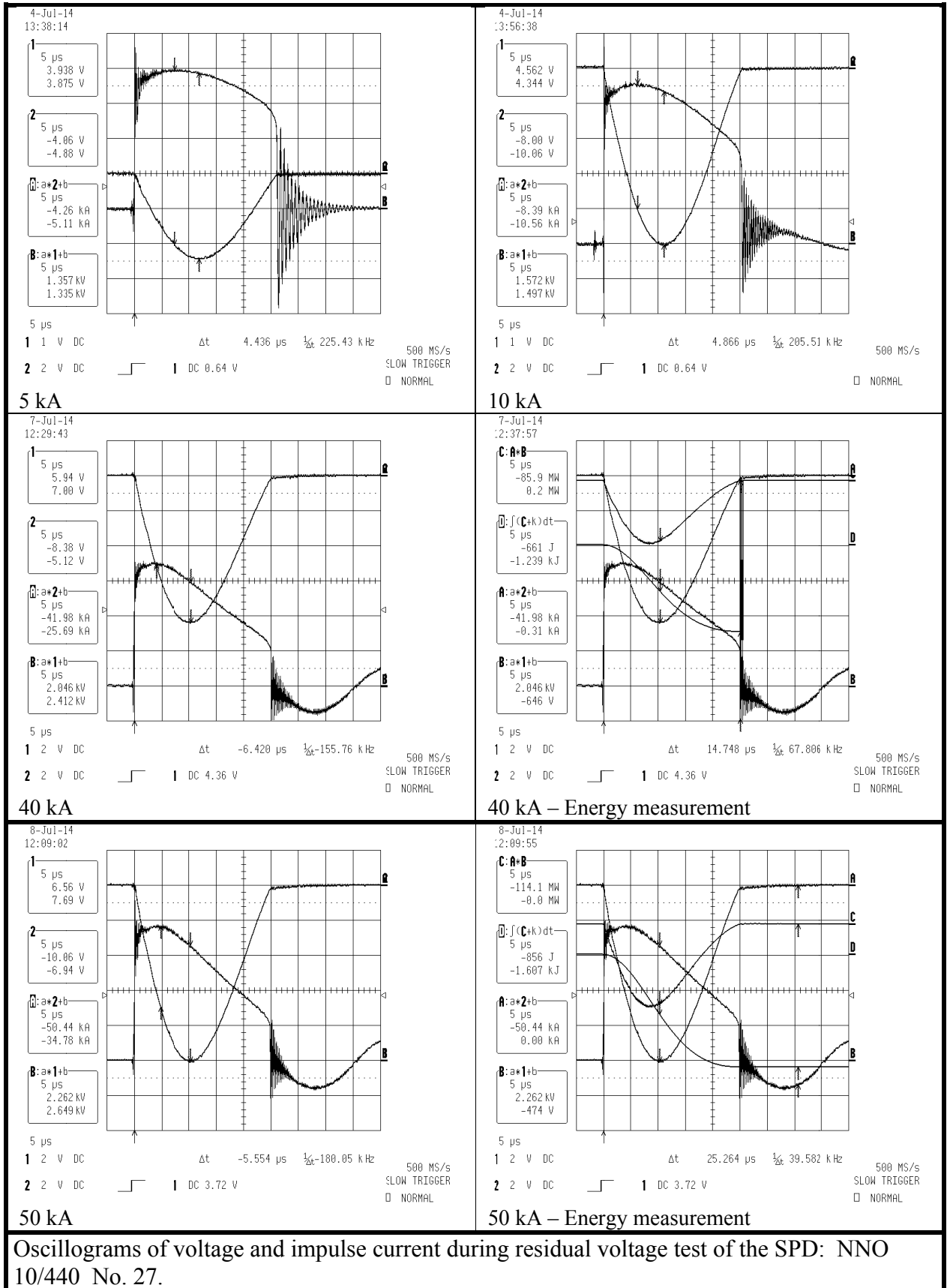

Oscillograms of voltage and impulse current during residual voltage test of the SPD: NNO 10/440 No. 27.

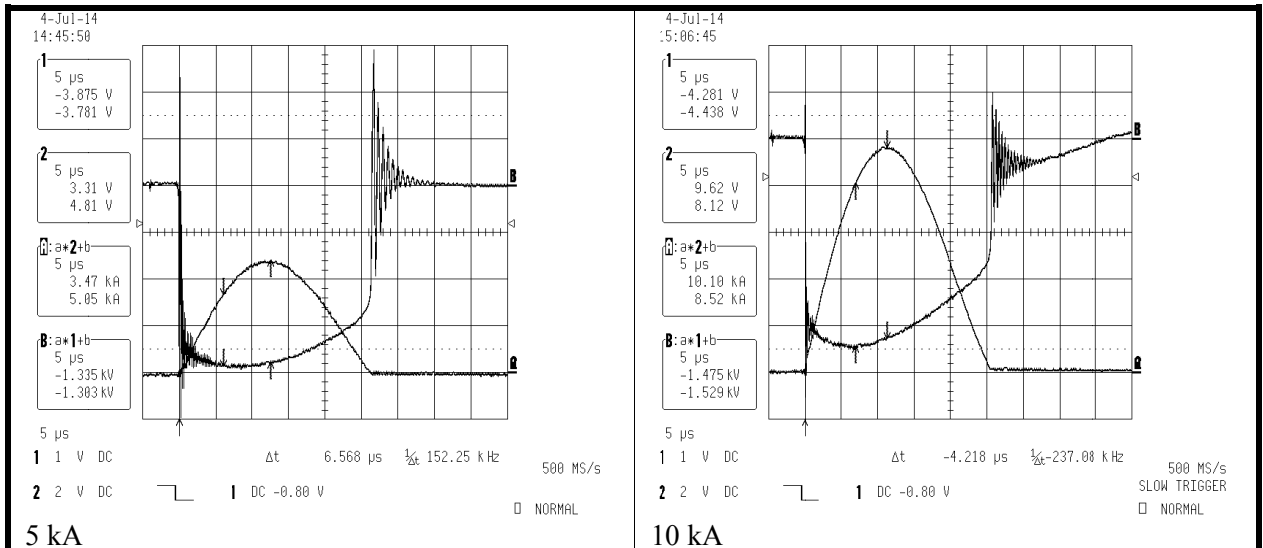

Oscillograms of voltage and impulse current during residual voltage test of the SPD: NNO 10/440 No. 27.

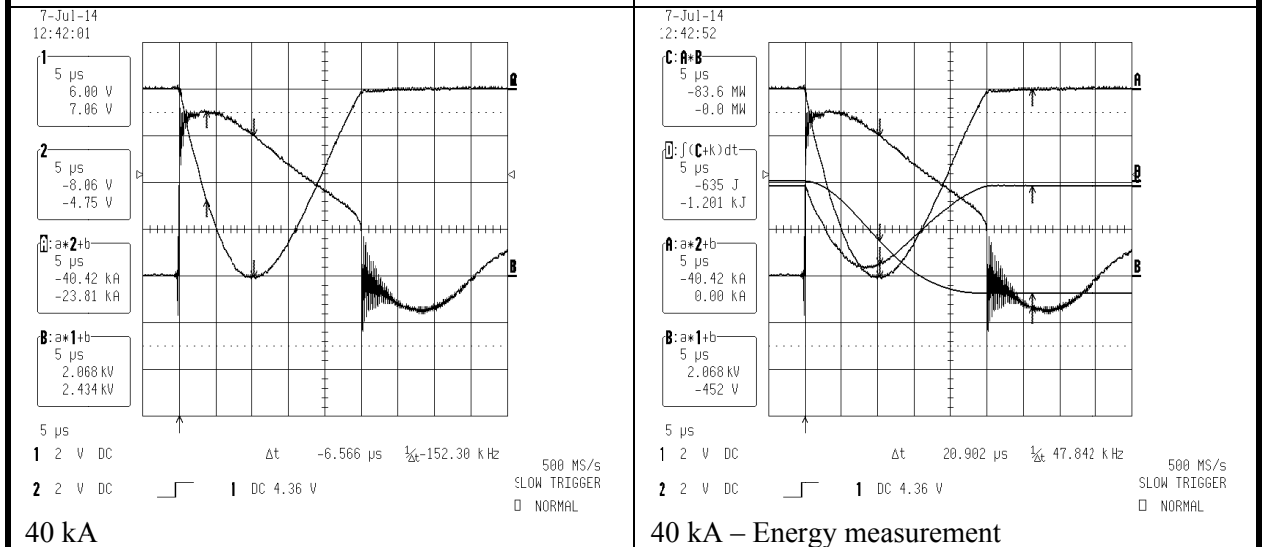
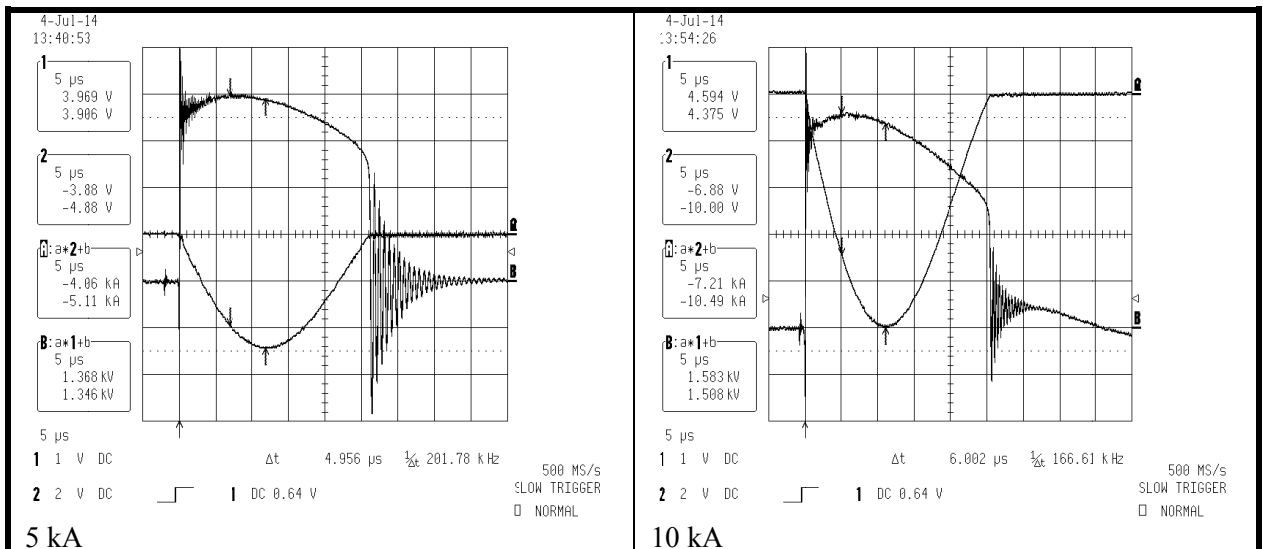

Oscillograms of voltage and impulse current during residual voltage test of the SPD: NNO 10/440 No. 28.

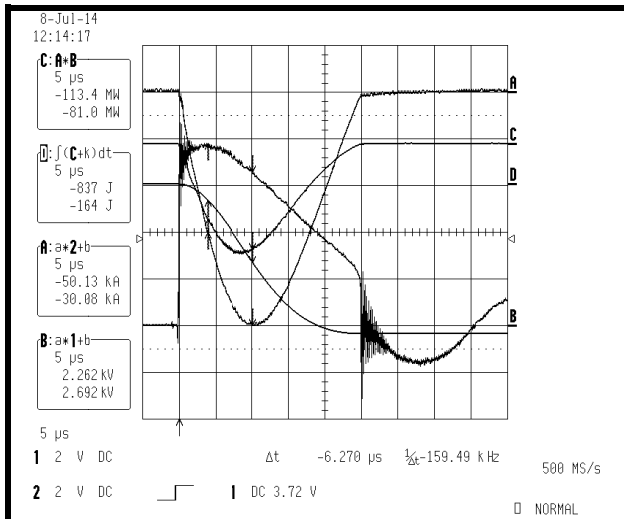

50 kA

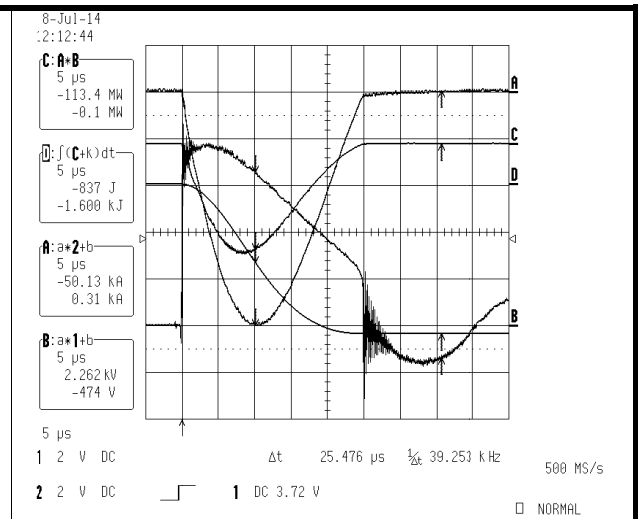

50 kA – Energy measurement

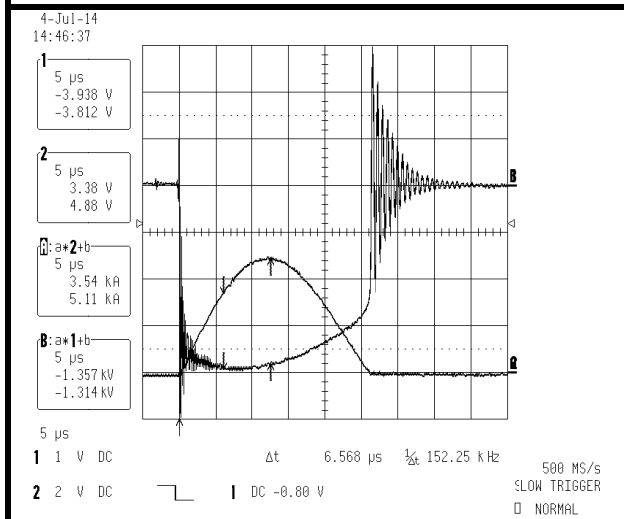

5 kA

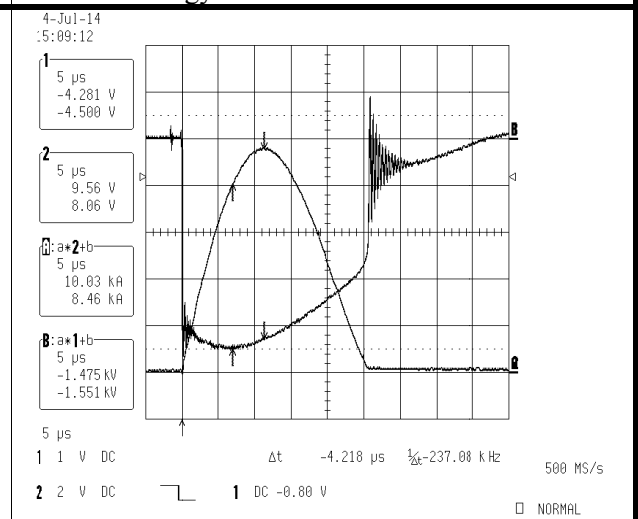

10 kA

Oscillograms of voltage and impulse current during residual voltage test of the SPD: NNO 10/440 No. 28.

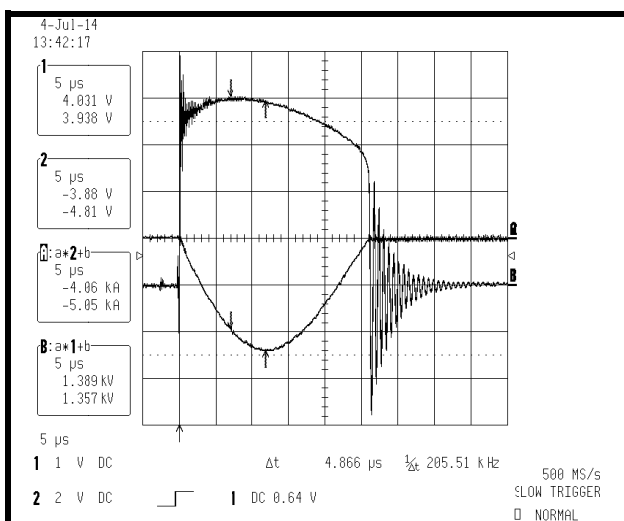

5 kA

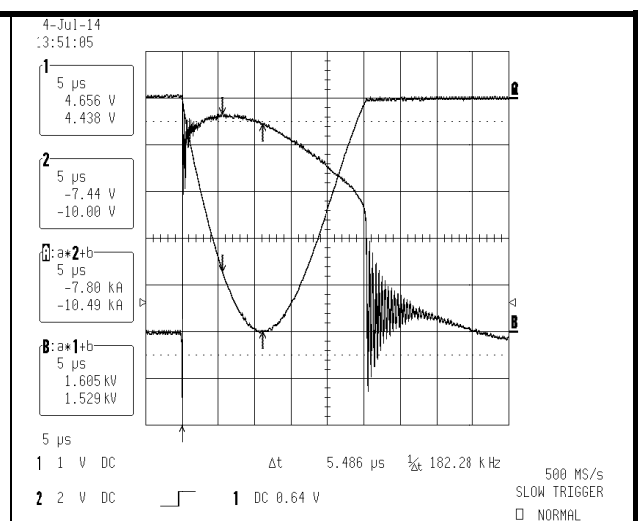

10 kA

Oscillograms of voltage and impulse current during residual voltage test of the SPD: NNO 10/440 No. 29.

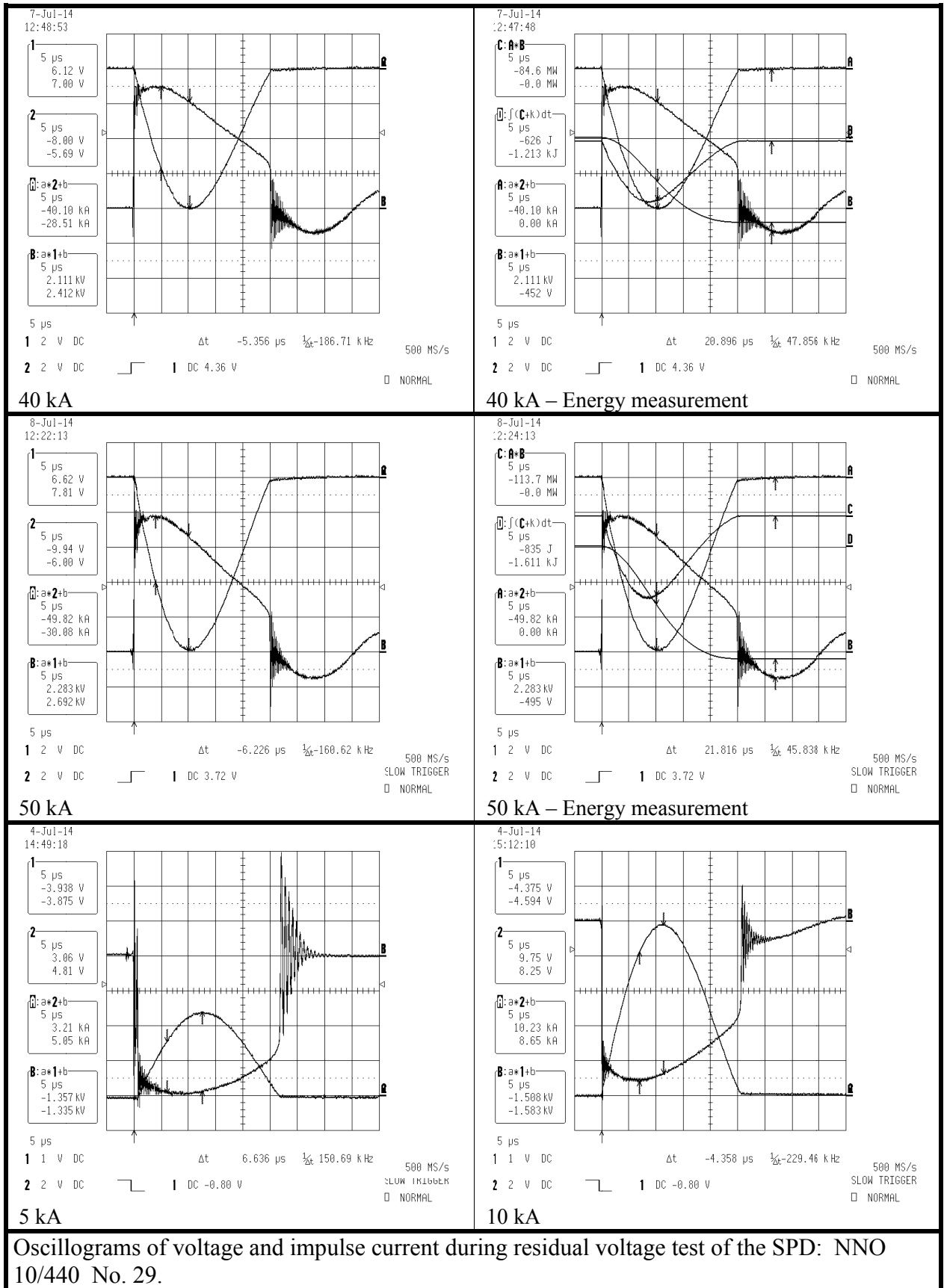

Oscillograms of voltage and impulse current during residual voltage test of the SPD: NNO 10/440 No. 29.

For the residual voltage test were used SPD's with 0,13 m length earthing wire.

### 13. Insulation resistance

EN 61643-11:2012 cl. 8.3.6

IEC 61643-11:2011 cl. 8.3.6

The test was carried out in Testing and Calibrating Laboratory (NBW) in the Electrotechnical Institute and was written in test report: 400/NZL/NBW/2014/O.

### 14. Dielectric withstand

EN 61643-11:2012 cl. 8.3.7

IEC 61643-11:2011 cl. 8.3.7

For the test were used SPD's without varistors.

Ambient conditions:

Ambient temperature	18,9 <sup>0</sup> C
Atmospheric Pressure	1002 hPa
Relative humidity	49,7%

Precipitation conditions for wet test

Temperature of the water	16 °C
Resistivity of the water	115 Ωm
Average precipitation – vertical component	2 mm/min
Average precipitation – horizontal component	2 mm/min

Dielectric withstand	NNO 10/440		
	No. D	No. E	No. F
Initially pre-wetted before test - unconditioned mains water [min]	15	15	15
Initially pre-wetted before test - standard water with all precipitation condition [min]	2	2	2
Test voltage [50Hz][V]	2240	2235	2234
Duration [s]	60	60	60
Remarks	Didn't arcing or puncturing	Didn't arcing or puncturing	Didn't arcing or puncturing
Result of the test	Passed	Passed	Passed

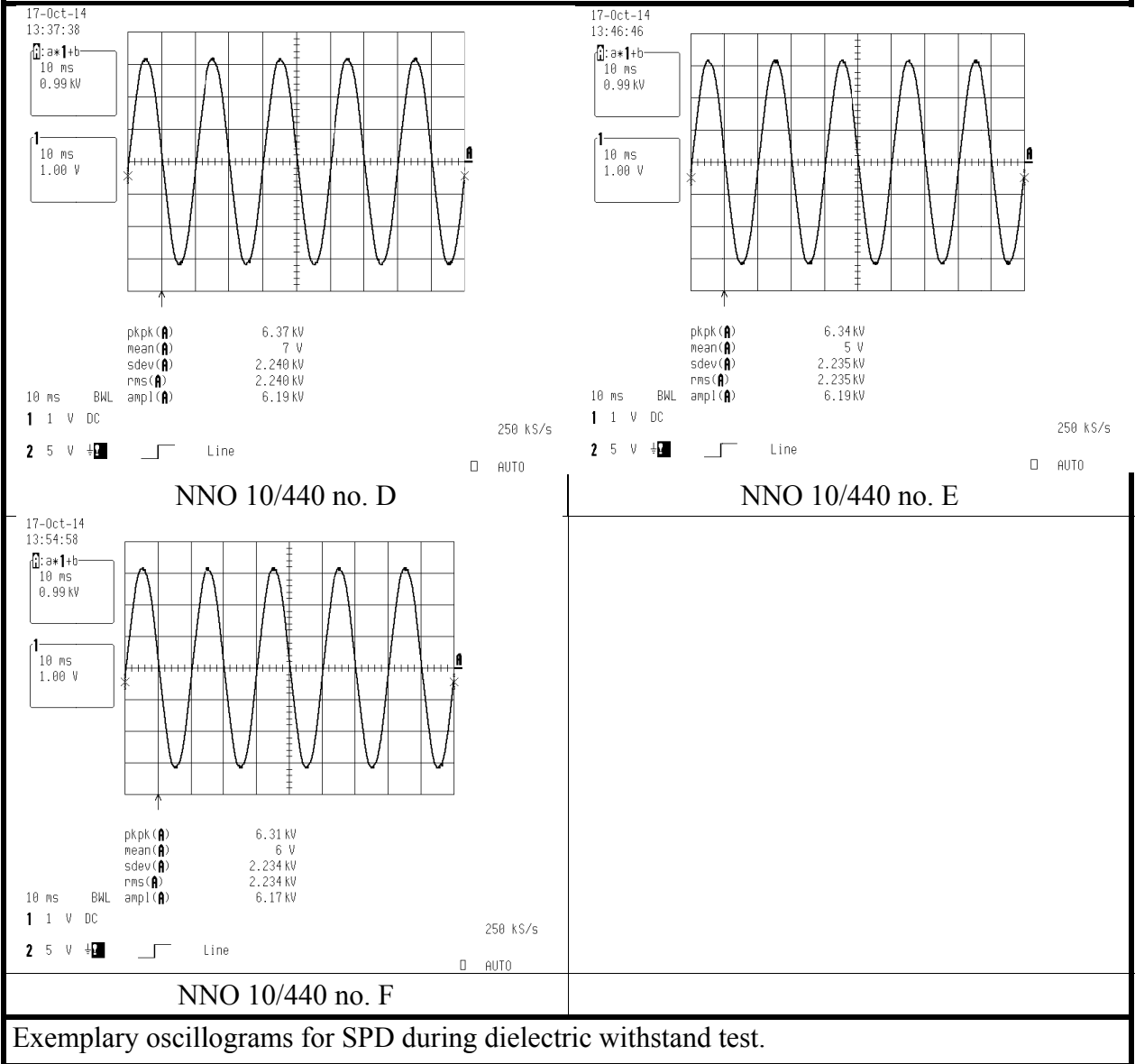

## 15. Mechanical strength – Impact test

EN 61643-11:2012 cl. 8.4.4  
IEC 61643-11:2011 cl. 8.4.4

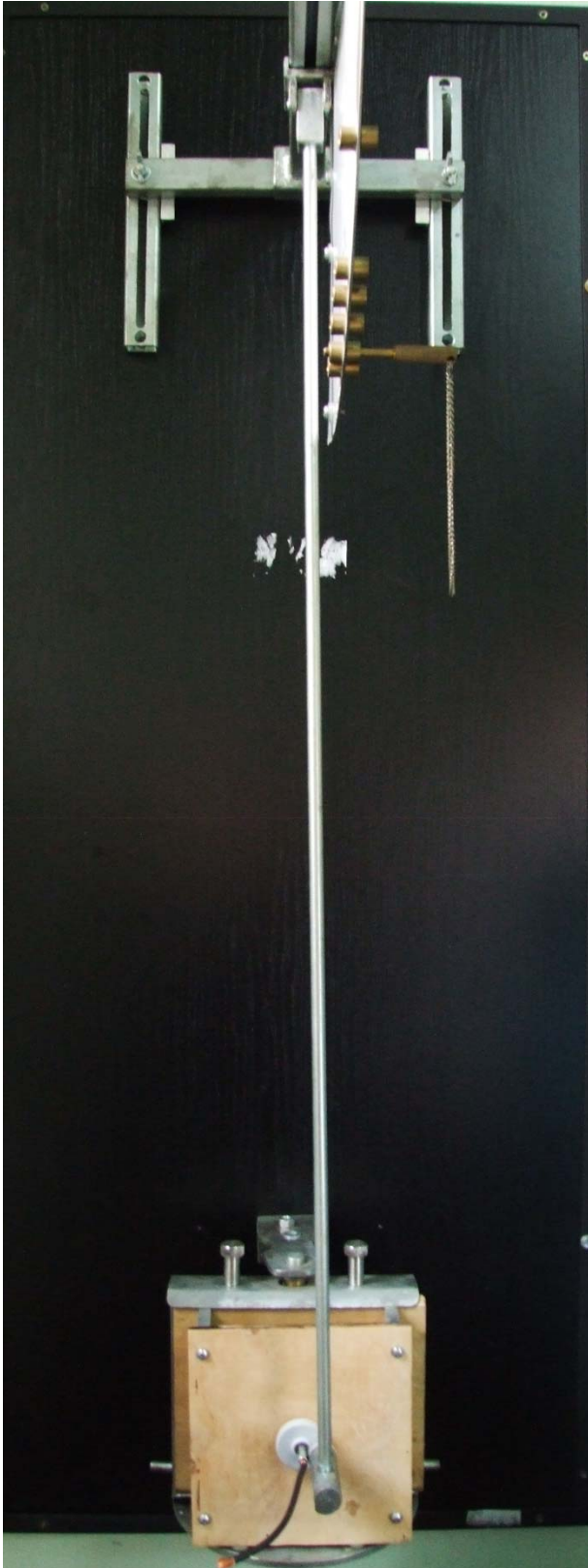

Test apparatus for impact test.

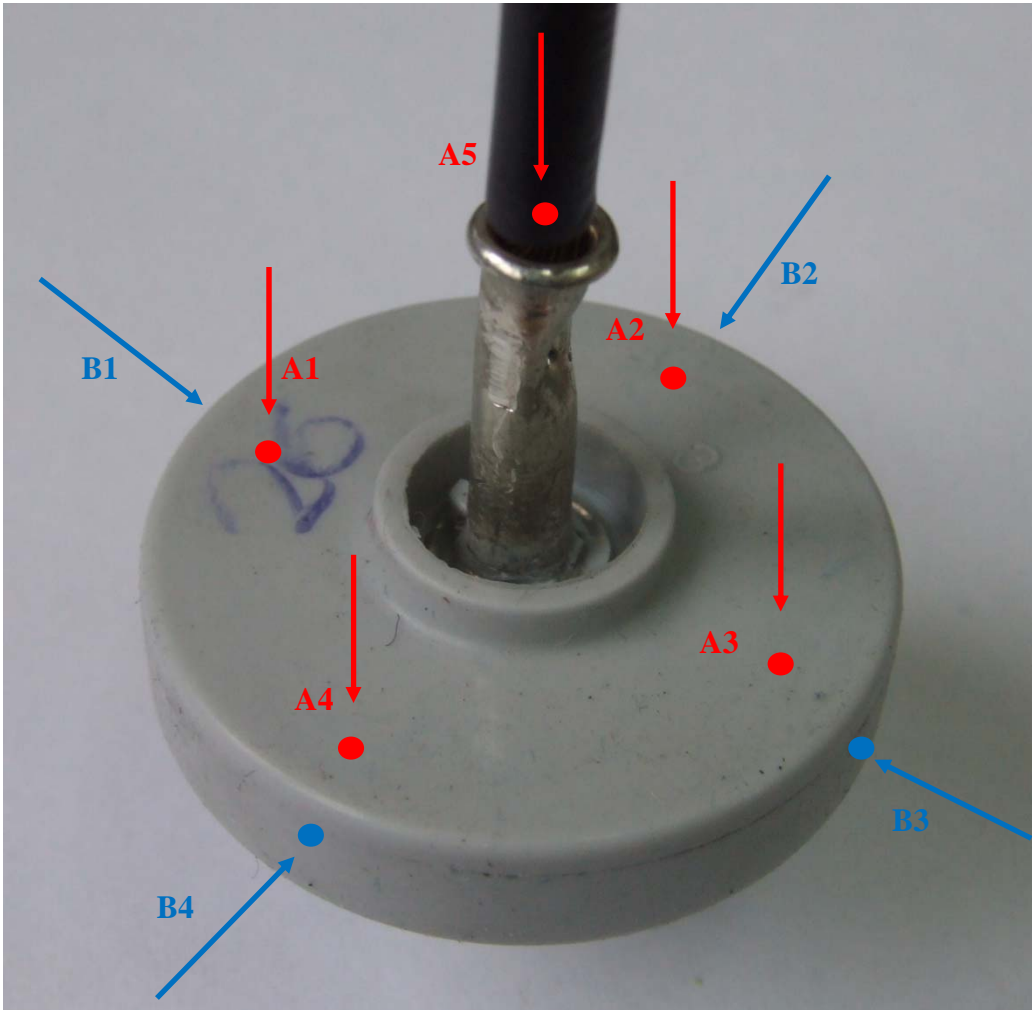

Points , where the striking element hit on the SPD's surface. Red points – parts A. Blue points – parts B.

Impact test	NNO 10/440 No. 24 [cm]	NNO 10/440 No. 25 [cm]	NNO 10/440 No. 26 [cm]
A1	10	10	10
A2	10	10	10
A3	10	10	10
A4	10	10	10
A5	10	10	10
B1	10	10	10
B2	10	10	10
B3	10	10	10
B4	10	10	10
Remarks	No damage	No damage	No damage
Test result	Passed	Passed	Passed



## 16. Temperature withstand

EN 61643-11:2012 cl. 8.3.5.1

IEC 61643-11:2011 cl. 8.3.5.1

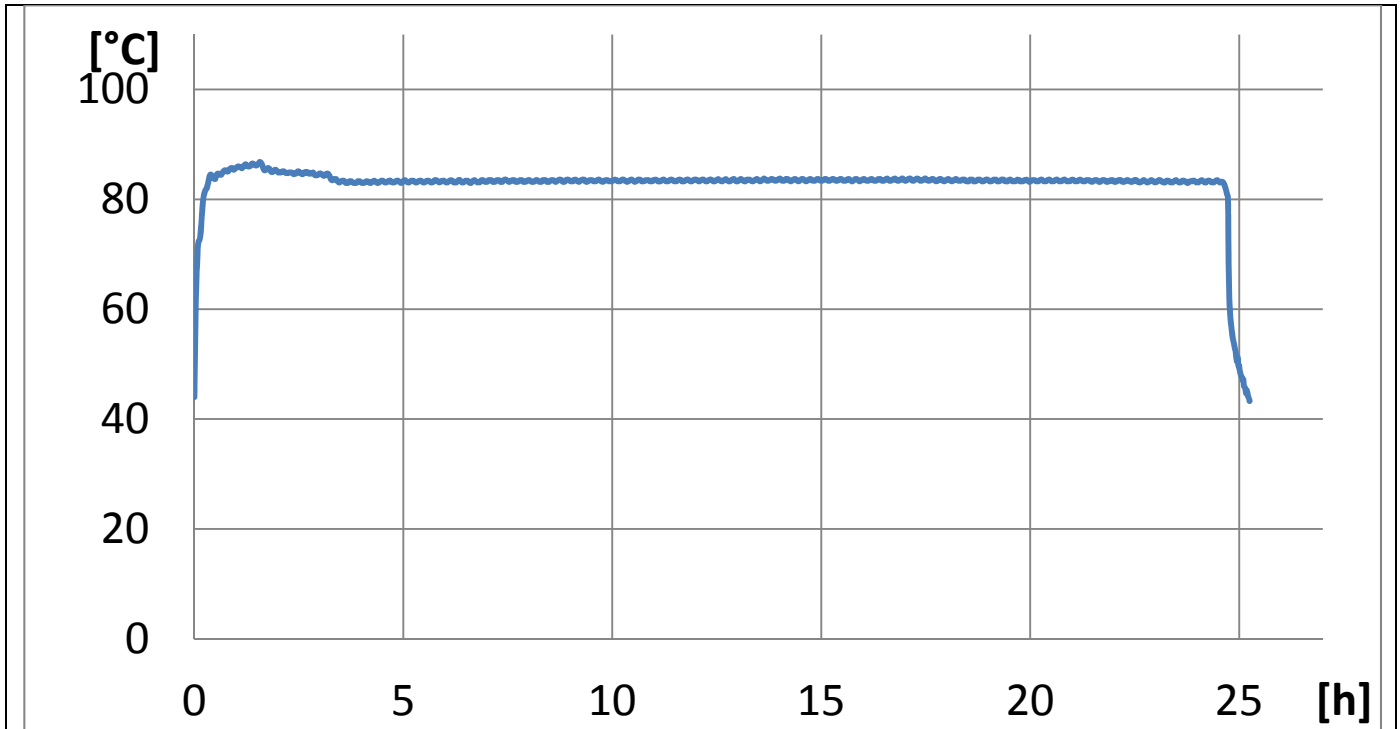

The temperature registered in the heated cabinet during temperature withstand test.

Pass criteria for temperature withstand test for NNO 10/440:

	no. 10	no. 11	no. 12
C	Was applied	Was applied	Was applied
G			
Test result	Passed	Passed	Passed



View of the SPD's type NNO after temperature withstand test.

## 17. Heat resistance

EN 61643-11:2012 cl. 8.5.2  
IEC 61643-11:2011 cl. 8.5.2

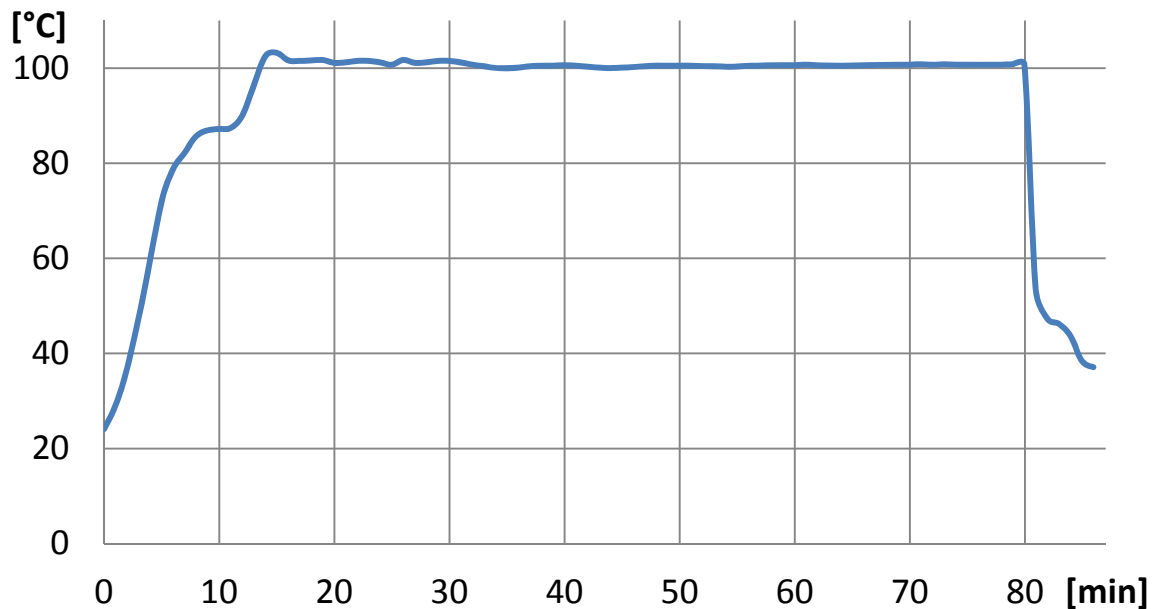

The temperature registered in the heated cabinet during heat resistance test.

Pass criteria for heat resistance test for NNO 10/440:

	no. 24	no. 25	no. 26
C	Was applied	Was applied	Was applied
I			
Additional pass criteria	Was applied	Was applied	Was applied
Disconnecter	didn't operate	didn't operate	didn't operate
Test result	Passed	Passed	Passed

## 18. TOVs caused by faults or disturbances in the low voltage system

EN 61643-11:2012 cl. 8.3.8.1

IEC 61643-11:2011 cl. 8.3.8.1

Acc. to cl. 7.2.8.1 for NNO 5/440 and NNO10/440 is no need to perform this test because test voltage  $U_T$  is lower and equal to  $U_c$ .

## 19. TOVs caused by faults in the high (medium) voltage system

EN 61643-11:2012 cl. 8.3.8.2

IEC 61643-11:2011 cl. 8.3.8.2

The SPDs type NNO are designed only for TN-systems. For TN-system is not carried out this test.

## 20. Short-circuit current behaviour

EN 61643-11:2012 cl. 8.3.5.3

IEC 61643-11:2011 cl. 8.3.5.3

The SPDs type NNO are classified for outdoor use and for mounting out of reach. For this use and mounting is not carried out this test.

## 5. IDENTIFICATION DOCUMENTATION. DRAWINGS

PROPERTY OF **IZOELEKTRO** s.p.a.

return drawing in case of  
cancelled production!

Copying and reproduction, handing  
to unauthorised persons or use for  
non-agreed purposes with the  
manufacturer is strictly  
forbidden!

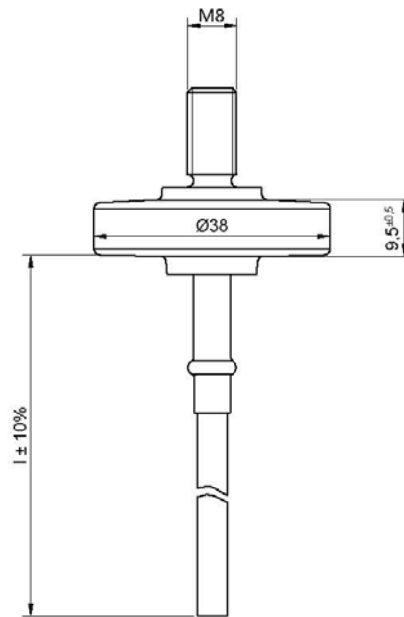

	Date	Name	Signature	Name	<b>IZOELEKTRO</b>
Construct	16.01.2015	M. Medved		LV Surge arrester NNO 10/440 - 0,5 m	
Revision	20.01.2015	D. Vouk			
Approved	22.01.2015	J. Hrastnik		Code 20 60 60	
Archive:					Units: mm

PROPERTY OF **IZOELEKTRO** s.c.  
return drawing in case of  
cancelled production!

Copying and reproduction, handing  
to unauthorised persons or use for  
non-agreed purposes with the  
manufacturer is strictly  
forbidden!

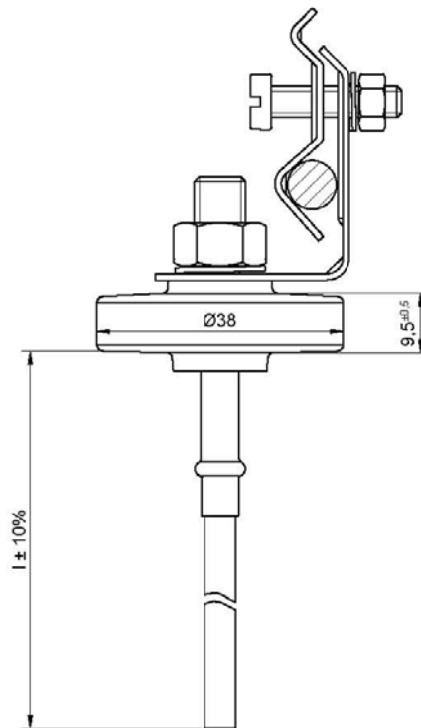

	Date	Name	Signature	Name	
Construct	16.01.2015	M. Medved		LV Surge arrester NNO 10/440 - 0,5 m + Connector P1	<b>IZOELEKTRO</b>
Revision	20.01.2015	D. Vouk			
Approved	22.01.2015	J. Hraštnik			
				Code	20 60 63
Archive:					Units: mm

PROPERTY OF **IZOELEKTRO** s.o.o.  
return drawing in case of  
cancelled production!

Copying and reproduction, handling  
to unauthorised persons or use for  
non-agreed purposes with the  
manufacturer is strictly  
forbidden!

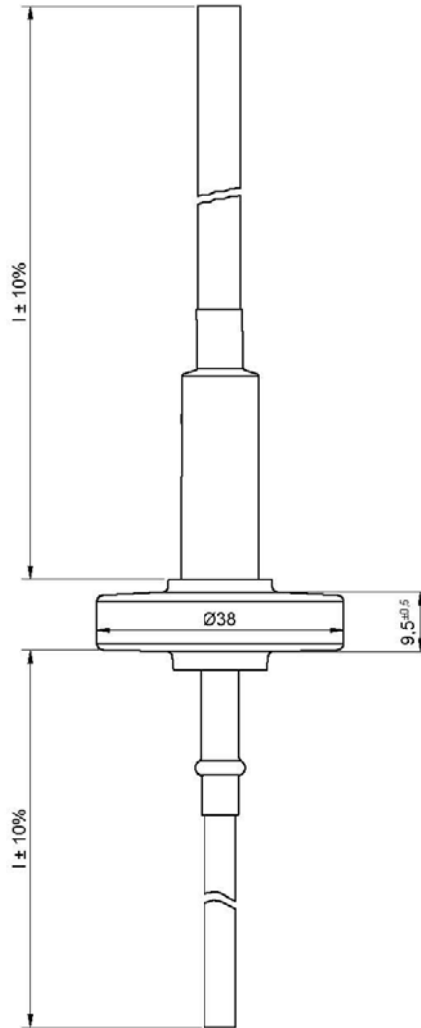

	Date	Name	Signature	Name	
Construct	16.01.2015	M. Medved		LV Surge arrester NNO 10/440 - 0,5 m + Connector P2 0,5m	<b>IZOELEKTRO</b>
Revision	20.01.2015	D. Vouk			
Approved	22.01.2015	J. Hraštnik			
				Code	20 60 64
Archive:					Units: mm

PROPERTY OF **IZOELEKTRO** s.o.o.  
return drawing in case of  
cancelled production!

Copying and reproduction, handling  
to unauthorised persons or use for  
non-agreed purposes with the  
manufacturer is strictly  
forbidden!

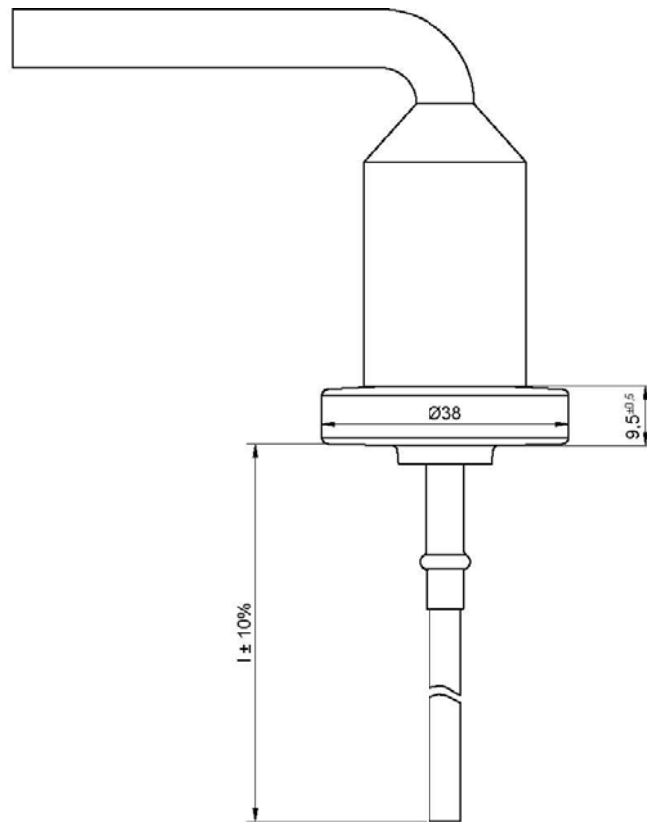

	Date	Name	Signature	Name	
Construct	16.01.2015	M. Medved		LV Surge arrester NNO 10/440 - 0,5 m + Connector P3	<b>IZOELEKTRO</b>
Revision	20.01.2015	D. Vouk			
Approved	22.01.2015	J. Hraštnik			
				Code	20 60 65
Archive:					Units: mm

# THE TESTING LABORATORIES ASSOCIATION OF THE ELECTROTECHNICAL INSTITUTE



## THE TESTING & CALIBRATING LABORATORY

Testing and calibrating laboratory accredited by Polish Centre for Accreditation, a signatory to EA MLA and ILAC MRA that include recognition of calibration certificates and test reports. Accreditation No AB 022 and AP 102



AB 022



Test fields: acoustics, electrotechnics, mechanics, vibrations, photometry, chemical and physical properties, functionality, safety, electromagnetic compatibility, fire resistance, flammability, climatic and mechanical hazard resistance.

## Test Report No 178/NZL/NBW/2014/O

Test object:	The Surge Protection Devices: NNO 10/280, NNO 10/440
Applicant:	IzoElektro d.o.o. Limbuška cesta 2, SI – 2341 Limbuš
Manufacturer:	as above
Mark and date of commission:	3/13 B-PL/1623 / 13.05.2014
Type of tests	Flammability
Standard:	PN-EN 60695-2-10:2013 (equivalent with the IEC 60695-2-10:2013) PN-EN 60695-2-11:2005 (equivalent with the IEC 60695-2-11:2001 + AC1:2000) PN-EN 61643-11:2013 (equivalent with the EN 61643-11:2012)
Number of pages of test report:	4
Number of attachments:	0
Date of receipt of test item:	13.05.2014
Date of start of test:	21.05.2014
Date of end of test:	21.05.2014
Final result of tests:	The tested object in the scope of test have been found in comply with the requirements of PN-EN 60695-2-11:2005 and PN-EN 62643-11:2013 (point 8.5.4) standards.
Additional information:	---

Warsaw, 6<sup>th</sup> June 2014

Authorized by:

Manager of SBF

Dariusz Grochowina, Eng.

Zespół Laboratoriów  
INSTYTUTU ELEKTROTECHNIKI  
ul. Pożaryskiego 28, 04-703 Warszawa  
tel. (22) 11-25-290, 11-25-300  
fax: (22) 11-25-444, 11-25-445  
e-mail: badania@iel.waw.pl, zwarcia@iel.waw.pl  
NIP: 525-000-76-84

Approved by:

Head of the Laboratory

Robert Franaszek, M.Sc.

*This report shall not be reproduced except in full without the written approval of the testing laboratory.*

*The test results presented in this report relate only to the object tested.*

Address:  
Mieczysława Pożaryskiego 28 St  
04-703 WARSZAWA

Bank: Pekao S.A.  
Account Number: 90 1240 6074 1111 0000 4999 4364  
NIP: 525-000-76-84

Ph.: (0-22) 812 30 53  
Fax: (0-22) 812 04 06  
badania@iel.waw.pl

## I. TESTED OBJECT CHARACTERISTICS

**Tested object description** .....

Trademark .....: Izoelektro

Model/Type .....: NNO 10/280

Ratings .....:  $I_n = 10 \text{ kA}$ ;  $U_p = 2,0 \text{ kV}$ ;  $U_c = 280 \text{ Vac}/355 \text{ Vdc}$ ; 50/60 Hz

Additional information .....: New objects

**Photographic identification of tested objects**





**Tested object description .....**

Trademark .....: Izoelektro

Model/Type.....: NNO 10/440

Ratings .....:  $I_n = 10 \text{ kA}$ ;  $U_p = 2,0 \text{ kV}$ ;  $U_c = 440 \text{ Vac}/585 \text{ Vdc}$ ; 50/60 Hz

Additional information.....: New objects

**Photographic identification of tested objects**



## II. TEST PROGRAM

According to the order, the test program contained all applicable tests and measurements, necessary for check of delivered objects resistance to heat, in test conditions specified in PN-EN 60695-2-11:2005 and PN-EN 62643-11:2013 (point 8.5.4) standards. Detailed list of test cases has been placed in III part of this Test Report.

## III. TEST RESULT

Specimens were tested in the following environmental conditions:

1. Relative humidity  $R_H = (46 - 51) \% \pm 5\%$
2. Ambient temperature  $T_a = (20,1 - 20,6) ^\circ\text{C} \pm 0,2 ^\circ\text{C}$

Test conditions:

1. Time of stabilization in above environment conditions - 24 h
2. Level of test severity:
  - test temperature:  $850 ^\circ\text{C} \pm 15 \text{ K}$
  - exposure time  $t_a = 30 \text{ s}$
3. The depth of penetration of glow wire in tested specimen:  $\leq 7 \text{ mm} \pm 0,5 \text{ mm}$
4. Kind of preparation of specimens to tests - finished products
5. Specimen's position during the test: long axis situated vertically

The results of tests summarized in below table:

Typ	Number of specimen	Place on or part of sample subjected to test	Ignition of test specimen during the test	Glowing of test specimen during the test	Time to ignition of the specimen $t_i$ (s)	Duration of burning $t_e$ (s)	Duration of glowing $t_e$ (s)	Limit of burning and/or glowing time (s)	The maximum height of the flame (mm)	Removal of burning material with glow wire	Ignition of the tissue paper	Test result
NNO 10/280	1	gray part of SPD	no	no	-	-	-	≤60	-	no	no	positive
NNO 10/440	2	gray part of SPD	no	no	-	-	-		-	no	no	positive

Tested by: Józef Stańczuk

# THE TESTING LABORATORIES ASSOCIATION OF THE ELECTROTECHNICAL INSTITUTE



## THE TESTING & CALIBRATING LABORATORY

Testing and calibrating laboratory accredited by Polish Centre for Accreditation, a signatory to EA MLA and ILAC MRA that include recognition of calibration certificates and test reports. Accreditation No AB 022 and AP 102



Test fields: acoustics, electrotechnics, mechanics, vibrations, photometry, chemical and physical properties, functionality, safety, electromagnetic compatibility, fire resistance, flammability, climatic and mechanical hazard resistance.



## Test Report No 400/NZL/NBW/2014/O

Test object:	The surge protection devices marked: NNO 10/280, NNO 10/440
Applicant:	IzoElektro d.o.o. Limbuška cesta 2, SI – 2341 Limbuš
Manufacturer:	as above
Mark and date of commission:	9/14C-PL/0001623 / 02.10.2014
Type of tests	Safety
Standard:	PN-EN 61643-11:2013 PN-EN 60112:2003+A1:2010 PN-EN 60695-10-2:2014
Number of pages of test report:	8
Number of attachments:	0
Date of receipt of test item:	15.12.2014
Date of start of test:	17.12.2014
Date of end of test:	12.02.2015
Final result of tests:	---
Additional information:	---

Warsaw, 20<sup>th</sup> February 2015

Authorized by:

Manager of SBF

Dariusz Grochowina, Eng.

Zespół Laboratoriów  
INSTYTUTU ELEKTROTECHNIKI  
ul. Pożaryskiego 28, 04-703 Warszawa  
tel. (22) 812-30-53; fax (22) 812-04-06  
tel. (22) 812-23-38; fax (22) 812-04-07  
e-mail: badania@iel.waw.pl, nwr@iel.waw.pl  
NIP 525-000-76-84

Approved by:

Head of the Laboratory

Robert Franaszek, M.Sc.

*This report shall not be reproduced except in full without the written approval of the testing laboratory.*

*The test results presented in this report relate only to the object tested.*

Address:  
Mieczysława Pożaryskiego 28 St  
04-703 WARSZAWA

Bank: Pekao S.A.  
Account Number: 90 1240 6074 1111 0000 4999 4364  
NIP: 525-000-76-84

Ph.: (0-22) 812 30 53  
Fax: (0-22) 812 04 06  
badania@iel.waw.pl

## I. TESTED OBJECT CHARACTERISTICS

**Tested object description** .....

Trademark .....: Izoelektro

Model/Type .....: NNO 10/280

Ratings .....:  $I_n = 10 \text{ kA}$ ;  $U_p = 2,0 \text{ kV}$ ;  $U_c = 280 \text{ Vac}/355 \text{ Vdc}$ ; 50/60 Hz

Additional information .....: New objects

**Photographic identification of tested objects**



**Tested object description** .....

Trademark .....: Izoelektro

Model/Type .....: NNO 10/440

Ratings .....:  $I_n = 10 \text{ kA}$ ;  $U_p = 2,0 \text{ kV}$ ;  $U_c = 440 \text{ Vac}/585 \text{ Vdc}$ ; 50/60 Hz

Additional information .....: New objects

**Photographic identification of tested objects**



## II. TEST PROGRAM

According to the order, the tests program contained all applicable measurements, necessary for check:

- 1) ball pressure test,
- 2) tracking resistance,
- 3) insulation resistance,
- 4) air clearances and creepage distances

of delivered objects, in test conditions specified in PN-EN 61643-11:2013 standard.

## III. TEST RESULT

Re 1 Ball pressure test.

Specimen was tested in the following environmental conditions:

1. Relative humidity  $R_H = (49 - 53) \% \pm 5\%$
2. Ambient temperature  $T_a = (22,2 - 22,6) ^\circ\text{C} \pm 0,5 ^\circ\text{C}$

Test conditions:

1. Time of stabilization in above environment conditions - 24 h
2. Level of test severity:
  - test temperature:  $70 ^\circ\text{C} \pm 2 \text{ K}$
  - exposure time  $t_a = 1 \text{ h}$
3. Kind of preparation of specimen to test: cut sample
4. Specimen dimension: 20 mm x 20 mm x 3 mm

The results of tests summarized in below table:

Tested object	Number of specimen	Place on or part of sample subjected to test	The spherical portion of the indentation left by the pressure ball (dimension D) [mm]	Test result
NNO 10/280, NNO 10/440	1	Middle of the sample	$0,3 \pm 0,1$	positive

Re 2 Tracking resistance.

Specimens were tested in the following environmental conditions:

1. Relative humidity  $R_H = (47 - 58) \% \pm 5\%$
2. Ambient temperature  $T_a = (21,2 - 22,4) ^\circ\text{C} \pm 0,2 ^\circ\text{C}$

Identification of tested specimens, information about the test preparation and the test result:

1.	Time of stabilization in above environment conditions:	24h
2.	Specimen dimension:	20 mm x 20 mm x 5 mm (2 layers)
3.	Kind of preparation of specimens to test:	cut samples, cleaned
4.	State of the surface:	the original surface of the material, no scratches
5.	Cleaning procedure:	electrode was purified by sandpaper
6.	Airflow:	tests were performed in a draught free space
7.	Orientation of the electrodes:	In accordance with clause 7.1 of PN-EN 60112:2 standard. The force exerted by each electrode on the surface of the test specimen was equal to $1,00 \text{ N} \pm 0,05 \text{ N}$

**Test result: CTI 175**

Re 3 Insulation resistance.

Before the test samples were kept in the humidity cabinet for 48 hours at a relative humidity of  $93\% \pm 3\%$  and a temperature  $(24,7 - 25,3) ^\circ\text{C} \pm 0,2 ^\circ\text{C}$ . Samples were removed from the cabin and after 30 min insulation resistance was measured. The results of tests summarized in below table:

Tested object	Resistance of insulation between:	Result
NNO 10/280	live parts and the SPD body	>50 MΩ
NNO 10/440	live parts and the SPD body	>50 MΩ

Re 4 Air clearances and creepage distances.

Minimum creepage distances and minimum air clearances for SPD were determined for pollution degree 3 and material group III.

$U_{max}$	Air clearances without accessory			Creepage distances without accessory			
	minimum limit (mm)	measured length		minimum limit (mm)		measured length	
	NNO 10/280 NNO 10/440	NNO 10/280	NNO 10/440	NNO 10/280	NNO 10/440	NNO 10/280	NNO 10/440
Between live parts of different polarity	≥3	36	38	≥5	≥8	39	41
Between live parts and:							
<ul style="list-style-type: none"> <li>screws and other means to fasten a covering, having to be detached for mounting the SPD</li> </ul>	≥3	- <sup>)</sup>	-	≥5	≥8	-	-
<ul style="list-style-type: none"> <li>fastening surfaces</li> </ul>	≥6	-	-	≥5	≥8	-	-
<ul style="list-style-type: none"> <li>screws or other means for fastening the SPD</li> </ul>	≥6	-	-	≥5	≥8	-	-
<ul style="list-style-type: none"> <li>bodies</li> </ul>	≥3	0	0	≥5	≥8	0	0
Between the metal parts of the disconnector mechanism and:							
<ul style="list-style-type: none"> <li>bodies</li> </ul>	≥3	-	-	≥5	≥8	-	-
<ul style="list-style-type: none"> <li>screws or other means for fastening the SPD</li> </ul>	≥3	-	-	≥5	≥8	-	-

<sup>)</sup> symbol: - means the requirement does not apply to the tested object



TESTING & CALIBRATING LABORATORY OF THE ELECTROTECHNICAL INSTITUTE

U <sub>max</sub>	Air clearances with Connector P2			Creepage distances with Connector P2			
	minimum limit (mm)	measured length		minimum limit (mm)		measured length	
	NNO 10/280 NNO 10/440	NNO 10/280	NNO 10/440	NNO 10/280	NNO 10/440	NNO 10/280	NNO 10/440
Between live parts of different polarity	≥3	39	41	≥5	≥8	41	43
Between live parts and:							
<ul style="list-style-type: none"> <li>screws and other means to fasten a covering, having to be detached for mounting the SPD</li> </ul>	≥3	- <sup>*)</sup>	-	≥5	≥8	-	-
<ul style="list-style-type: none"> <li>fastening surfaces</li> </ul>	≥6	-	-	≥5	≥8	-	-
<ul style="list-style-type: none"> <li>screws or other means for fastening the SPD</li> </ul>	≥6	-	-	≥5	≥8	-	-
<ul style="list-style-type: none"> <li>bodies</li> </ul>	≥3	0,4	0,4	≥5	≥8	0,4	0,4
Between the metal parts of the disconnector mechanism and:							
<ul style="list-style-type: none"> <li>bodies</li> </ul>	≥3	-	-	≥5	≥8	-	-
<ul style="list-style-type: none"> <li>screws or other means for fastening the SPD</li> </ul>	≥3	-	-	≥5	≥8	-	-

<sup>\*)</sup> symbol: - means the requirement does not apply to the tested object

U <sub>max</sub>	Air clearances with Connector P3			Creepage distances with Connector P3			
	minimum limit (mm)	measured length		minimum limit (mm)		measured length	
	NNO 10/280 NNO 10/440	NNO 10/280	NNO 10/440	NNO 10/280	NNO 10/440	NNO 10/280	NNO 10/440
Between live parts of different polarity	≥3	39	41	≥5	≥8	41	43
Between live parts and:							
<ul style="list-style-type: none"> <li>screws and other means to fasten a covering, having to be detached for mounting the SPD</li> </ul>	≥3	- <sup>*)</sup>	-	≥5	≥8	-	-
<ul style="list-style-type: none"> <li>fastening surfaces</li> </ul>	≥6	-	-	≥5	≥8	-	-
<ul style="list-style-type: none"> <li>screws or other means for fastening the SPD</li> </ul>	≥6	-	-	≥5	≥8	-	-
<ul style="list-style-type: none"> <li>bodies</li> </ul>	≥3	8	8	≥5	≥8	9	9
Between the metal parts of the disconnector mechanism and:							
<ul style="list-style-type: none"> <li>bodies</li> </ul>	≥3	-	-	≥5	≥8	-	-
<ul style="list-style-type: none"> <li>screws or other means for fastening the SPD</li> </ul>	≥3	-	-	≥5	≥8	-	-

<sup>\*)</sup> symbol: - means the requirement does not apply to the tested object

Tested by: Józef Stańczuk