



Cryogenics Group

Creating a Better
Tomorrow Through
Innovative Solutions





An Overview

Sumitomo Heavy Industries, Ltd. (SHI) has a tradition of excellence and innovation that spans over 400 years. From its very beginning as a small shop selling medicines and books in Kyoto, Japan, in the early 17th century, to its current status as a diverse, \$8 billion corporation, SHI has continued to grow and flourish in an ever-changing international market.

SHI's acquisition of IGC-APD Cryogenics, Inc. in 2002 brought together two of the world's leading cryogenic companies to form the SHI Cryogenics Group, with an unsurpassed tradition of design, development and success in the manufacture of cryogenic equipment.

SHI Cryocoolers continue this tradition by supporting both global research & development, as well as state-of-the-art technologies. Today, applications of cryogenic technologies can be found in our daily lives.

1959



Precursor to APD Cryogenics established as Space and Missile Department of Air Products in Allentown, Pennsylvania, USA

1962



Sumitomo establishes its cryogenics business at the Hiratsuka Research Laboratory in Hiratsuka City, near Tokyo

1962

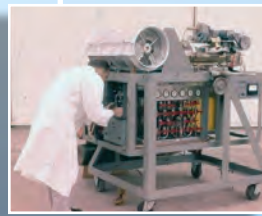

Air Products' Space and Missile Department renamed the Advanced Product Development Department (APD)

1968



APD introduces Displex® cryocooler systems

SHI Cryocoolers are used directly or in the manufacturing of many of the world's medical, semiconductor, telecommunications, electronics, biochemical and other industrial products.

SHI offers a wide range of Cryocooler products: Gifford-McMahon, Pulse Tube and other specialty Cryocoolers, with temperatures ranging from below 4K to 77K and higher. SHI Cryocoolers are built in world-class manufacturing facilities using the latest Six Sigma manufacturing and process capabilities. The result is a product portfolio that offers flexibility, high reliability and is supported by a global sales, service and support network.

1969



Merger between Sumitomo Machinery and Uruga Heavy Industries results in the establishment of Sumitomo Heavy Industries, Ltd. (SHI)

1976



APD pioneers current-generation cryopump technology

1982

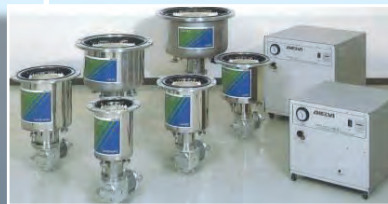

SHI's merger with Nittoku Metal Industries results in the establishment of the Precision Machinery Division, which today includes the Cryogenics Group

1987

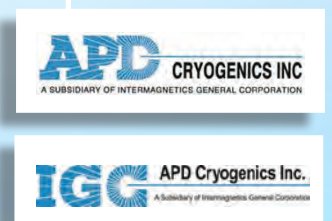

APD becomes a subsidiary of Intermagnetics General Corporation and is renamed IGC-APD Cryogenics, Inc.

An Overview, cont.

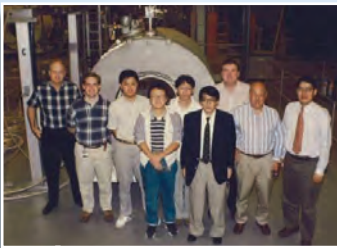

1996

SHI begins designing and manufacturing 4K GM Cryocoolers for MRI applications



1999

SHI opens Sumitomo (SHI) Cryogenics of America, Inc. (SCAI) near Chicago, IL, USA, the first Cryogenics Group office in the United States.



2000

SHI opens Sumitomo (SHI) Cryogenics of Europe GmbH (SCEG) in Darmstadt, Germany, the first Cryogenics Group office in Europe.



2001

SHI opens SHI Manufacturing & Services (Philippines), Inc. (SHImS) in Batangas, Philippines.

2008



Sumitomo (SHI) Cryogenics Korea Co., Ltd. (SCKL) opens in Suwon City, South Korea.

2011



SHI develops a separated valve unit option for pulse tube models. This technology further reduces vibration, enables operation in higher magnetic fields and eases maintenance requirements.

2012



Sumitomo (SHI) Cryogenics Taiwan Co., Ltd. (SCTW) opens in Hsinchu City, Taiwan.

2013



Sumitomo (SHI) Cryogenics of America, Inc. opens its fourth and fifth offices in Austin, TX and Malta, NY.



2002

IGC-APD Cryogenics, Inc. becomes a subsidiary of Sumitomo Heavy Industries, Ltd., which eventually leads to the creation of the SHI Cryogenics Group.



2002

SHI develops its first pulse tube cryocoolers.



2004

Sumitomo Heavy Industries (Shanghai) Management, Ltd. [now Sumitomo (SHI) Cryogenics Shanghai, Ltd. (SCSL)] opens in Shanghai, China. The same year, SHI acquires Daikin Industries, Ltd.'s cryogenics business, expanding its global sales and service reach.



2005

SHI develops two new cryopump lines. The SICERA® cryopump system is a unique, energy-saving product designed especially for the semiconductor industry. Marathon® CP Cryopumps meet the needs of high vacuum processes, including vacuum coating systems and custom laboratory equipment.



2013



SHI develops the FA line of air-cooled compressors, based on the proven technology found in Freedom® series water-cooled compressors.

2015



During the 2015 SHI Innovation Awards, the SHI Cryogenics Group wins a silver medal in Technology Development, for advancements in 4K pulse tube design, and a bronze medal in Sales and Service, for contributions to the growth of the after-market MRI business.

2017



The SHI Cryogenics Group acquires Ferran Technologies, which provides leading-edge vacuum measurement and control instrumentation to the micro-electronics manufacturing industries. This creates the sixth US location, in San Diego, CA.

Today



The SHI Cryogenics Group has thirteen locations, including its world headquarters in Tokyo, offering customers a global sales, service and support network.



4K Cryocoolers

Cold Head Model		RDK-101D(L)	RDK-305D	RDK-205D	RDK-408D2	RDE-412D4	RDK-415D	RDE-418D4
2nd Stage Capacity	50 Hz	0.16 W @ 4.2 K ¹	0.4 W @ 4.2 K	0.5 W @ 4.2 K	1.0 W @ 4.2 K	1.25 W @ 4.2 K	1.5 W @ 4.2 K	1.8 W @ 4.2 K
	60 Hz	0.2 W @ 4.2 K ¹	0.4 W @ 4.2 K	0.5 W @ 4.2 K	1.0 W @ 4.2 K	1.25 W @ 4.2 K	1.5 W @ 4.2 K	2.0 W @ 4.2 K
1st Stage Capacity	50 Hz	3.0 W @ 45 K	15 W @ 40 K	10 W @ 50 K	40 W @ 43 K	53 W @ 43 K	35 W @ 50 K	42 W @ 50 K
	60 Hz	5.0 W @ 45 K	20 W @ 40 K	13 W @ 50 K	50 W @ 43 K	60 W @ 43 K	45 W @ 50 K	50 W @ 50 K
Minimum Temperature ²		<3.0 K (RDK-101D)/ <2.3 K (RDK-101DL)	<3.5 K	<3.5 K	<3.5 K	<3.5 K	<3.5 K	<3.5 K
Cooldown Time (min) ²	50 Hz	<150	<120	<90	<60	<60	<60	<60
	60 Hz	<150	<120	<90	<60	<60	<60	<60
Weight		7.2 kg (15.9 lbs.)	16.0 kg (35.3 lbs.)	14.0 kg (30.9 lbs.)	18.0 kg (39.7 lbs.)	20.0 kg (44.1 lbs.)	18.5 kg (40.8 lbs.)	20.0 kg (44.1 lbs.)
Water-Cooled Compressor Options								
HC-4E		•						
CKW-21A				•				
F-40L/H			•	•		3		
F-50L/H					•	•	•	•
F-50SL/H						•		•
F-70L/H					•	3	•	•
Air-Cooled Compressor Options								
CNA-11		•						
Zephyr [®]		•						
FA-40L/H			•	•		3		
CSA-71A					•	•	•	•
FA-70L/H					•		•	

1 With CNA-11 Compressor, 2nd stage capacity is 0.1 W @ 4.2 K (50/60 Hz). 1st stage capacity is 3.0/5.0 W @ 60 K (50/60 Hz).

2 Lowest temperature and cooldown time are for reference only. However, lowest temperature for RDK-101DL is guaranteed.

3 Reduced capacities when operated with F-40, F-70 or FA-40 Compressors. Please contact SHI for more details.

4 Up to two (2) cold heads can be operated with the F-70 Compressor.

Specifications subject to change without notice.



10K Cryocoolers

Cold Head Model		CH-202	CH-204	CH-208R	CH-208L	CH-210	RDK-408S
2nd Stage Capacity	50 Hz	2.0 W @ 20 K	7.5 W @ 20 K	6.0 W @ 20 K	8.0 W @ 20 K	6.0 W @ 20 K	5.4 W @ 10 K
	60 Hz	2.5 W @ 20 K	9.0 W @ 20 K	7.5 W @ 20 K	10.0 W @ 20 K	7.0 W @ 20 K	6.3 W @ 10 K
1st Stage Capacity	50 Hz	7.3 W @ 77 K	13.5 W @ 80 K	65 W @ 77 K	28 W @ 77 K	110 W @ 77 K	30 W @ 45 K
	60 Hz	8.8 W @ 77 K	16.2 W @ 80 K	80 W @ 77 K	35 W @ 77 K	120 W @ 77 K	35 W @ 45 K
Minimum Temperature ²		10 K	10 K	10 K	10 K	10 K	<7 K
Cooldown Time (min) ²	50 Hz	75	35	55	50	60	<60
	60 Hz	65	30	45	40	50	<60
Weight		7.2 kg (16.0 lbs.)	7.8 kg (17.2 lbs.)	11.6 kg (25.6 lbs.)	11.8 kg (26.0 lbs.)	13.8 kg (30.4 lbs.)	17.2 kg (37.9 lbs.)
Bakeable Option		
Water-Cooled Compressor Options							
HC-4E		.	.				
HC-8E			.	.	.		
F-50L/H							.
F-70L/H			4	.	.	.	
Air-Cooled Compressor Options							
Zephyr [®]		.	.				
CSA-71A							.
FA-70L/H							.

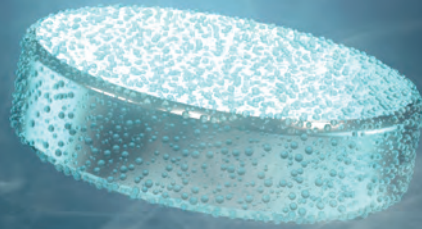

Pulse Tube Cryocoolers

Cold Head Model		RP-062B	RP-062BS	RP-082B2	RP-082B2S	RP-182B2S
2nd Stage Capacity	50 Hz	0.5 W @ 4.2 K	0.4 W @ 4.2 K	1.0 W @ 4.2 K	0.9 W @ 4.2 K	1.5 W @ 4.2 K
	60 Hz	0.5 W @ 4.2 K	0.4 W @ 4.2 K	1.0 W @ 4.2 K	0.9 W @ 4.2 K	1.5 W @ 4.2 K
1st Stage Capacity	50 Hz	30 W @ 65 K	25 W @ 65 K	40 W @ 45 K	35 W @ 45 K	36 W @ 48 K
	60 Hz	30 W @ 65 K	25 W @ 65 K	40 W @ 45 K	35 W @ 45 K	36 W @ 48 K
Minimum Temperature ¹		<3.0 K	<3.0 K	<3.0 K	<3.0 K	<2.8 K
Cooldown Time (min) ¹	50 Hz	<100	<100	<80	<90	<60
	60 Hz	<90	<90	<80	<90	<60
Weight		23.2 kg (51.1 lbs.)	23.5 kg (51.8 lbs.)	25.0 kg (55.1 lbs.)	26.0 kg (57.3 lbs.)	28.0 kg (61.7 lbs.)
Water-Cooled Compressor Options						
F-50L/H		•	•			
F-70LP/H				•	•	
F-100L/H						•
Air-Cooled Compressor Options						
FA-70L/H				4	4	

1 Lowest temperature and cooldown time are for reference only.

2 Up to two (2) cold heads can be operated with the F-70 Compressor.

3 Reduced capacities when operated with Zephyr, HC-4E or HC-8E Compressors.

4 Reduced capacities when operated with FA-70 Compressor.

5 RDK-500B operates with F-70LP and F-70H Compressors.

Specifications subject to change without notice.

Specialty Cryocoolers

Cold Head Model		CH-204-N	CH-210-N	CH-210L	RDK-400B	RDK-500B	RD-125D	CH-104	CH-110	CH-110LT
2nd Stage Capacity	50 Hz	2.5 W @ ≤10 K	—	9.5 W @ 20 K	—	—	—	—	—	—
	60 Hz	3.0 W @ ≤10 K	3.0 W @ 10 K	11 W @ 20 K	—	—	—	—	—	—
1st Stage Capacity	50 Hz	—	—	75 W @ 60 K	54 W @ 40 K	40 W @ 20 K 80 W @ 30 K	30 W @ 77 K	34 W @ 77 K	175 W @ 77 K	80 W @ 40 K
	60 Hz	—	20 W @ 35 K	90 W @ 60 K	70 W @ 40 K	45 W @ 20 K 94 W @ 30 K	30 W @ 77 K	42 W @ 77 K	200 W @ 77 K	95 W @ 40 K
Minimum Temperature ¹		6.5 K	10 K	10 K	<25 K	<14 K	<30 K	≤40 K	≤40 K	<15 K
Cooldown Time (min) ¹	50 Hz	40	—	<60	<30	<70	<25	<40	<35	<35
	60 Hz	35	60	<60	<30	<70	<25	<30	<30	<30
Weight		7.8 kg (17.2 lbs.)	13.8 kg (30.4 lbs.)	12.1 kg (26.7 lbs.)	16.0 kg (35.3 lbs.)	25.0 kg (55.1 lbs.)	15.0 kg (33.1 lbs.)	7.9 kg (17.5 lbs.)	13.7 kg (30.2 lbs.)	13.8 kg (30.5 lbs.)
Bakeable Option		•	•	•				•	•	•
Water-Cooled Compressor Options										
HC-4E		•						•	3	
HC-8E		•						•	3	
F-50L/H					•					
F-70L(P)/H		2	•	•		5		2	•	•
Air-Cooled Compressor Options										
CNA-11							•			
Zephyr [®]		•						•	3	
CSA-71A					•					
FA-70L/H					•				•	•



4K Cryocooler Series

- SHI's 4K Gifford-McMahon Cryocoolers are recognized as the most reliable and versatile systems available in the marketplace.
- They feature high cooling capacities, compact designs and are orientation-free.
- Models like the RDE-412D4 are the standard for MRI and other superconducting magnets.
- These 4K Cryocoolers are used in a wide variety of analytical and experimental devices, and offer a very cost effective alternative to open-cycle liquid helium systems.



RDK-101D



RDK-305D



RDK-205D



RDK-408D2



RDE-412D4



RDK-415D



RDE-418D4

RDK-101D 4K Cryocooler Series

Performance Specifications

Power Supply	50Hz	60 Hz
2 nd Stage Capacity ¹	0.16 W @ 4.2 K	0.2 W @ 4.2 K
1 st Stage Capacity ¹	3.0 W @ 45 K	5.0 W @ 45 K
Minimum Temperature ²	3.0 K (RDK-101D)/<2.3 K (RDK-101DL)	
Cooldown Time to 4.2 K ²	<150 Minutes	
Weight	7.2 kg (15.9 lbs.)	
Dimensions (HxWxD)	442 x 130 x 226 mm (17.4 x 5.1 x 8.9 in.)	
Maintenance	10,000 Hours	
Regulatory Compliance	UL/CE, RoHS	

Standard Scope of Supply

- RDK-101D(L) Cold Head
- HC-4E, CNA-11B/C or Zephyr[®] Compressor
- Helium Gas Lines – 3 m (10 ft.)³ or 3-20 m (10-66 ft.)⁴
- Cold Head Cable – 6 m (20 ft.)³ or 3.5-20 m (11-66 ft.)⁴
- Power Cable – 5 m (16.5 ft.)³
- Tool Kit

¹With CNA-11B/C compressors, 2nd stage capacity is 0.1 W @ 4.2 K (50/60 Hz). 1st stage capacity is 3.0/5.0 W @ 60 K (50/60 Hz).

²Lowest temperature and cooldown time are for reference only. However, lowest temperature for RDK-101DL is guaranteed.

³With CNA-11B/C

⁴With HC-4E or Zephyr[®]



RDK-101D Cold Head Capacity Map (50 Hz)

With Zephyr[®] Compressor and 3 m (10 ft.) Helium Gas Lines

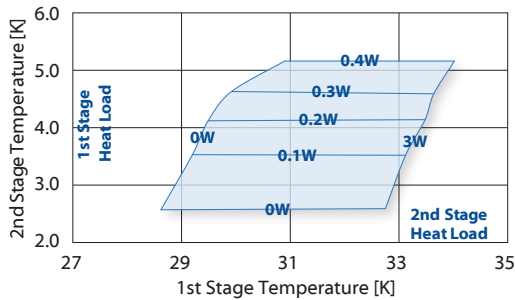

RDK-101D Cold Head Capacity Map (60 Hz)

With Zephyr[®] Compressor and 3 m (10 ft.) Helium Gas Lines

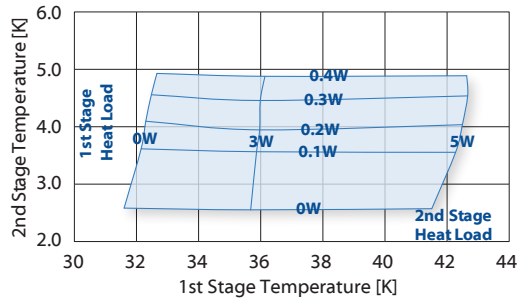

RDK-305D 4K Cryocooler Series

Performance Specifications

Power Supply	50Hz	60 Hz
2 nd Stage Capacity	0.4 W @ 4.2 K	
1 st Stage Capacity	15 W @ 40 K	20 W @ 40 K
Minimum Temperature ¹	<3.5 K	
Cooldown Time to 4.2 K ¹	<120 Minutes	
Weight	16.0 kg (35.3 lbs.)	
Dimensions (HxWxD)	512 x 180 x 294 mm (20.2 x 7.1 x 11.6 in.)	
Maintenance	10,000 Hours	
Regulatory Compliance	UL/CE, RoHS	

Standard Scope of Supply

- RDK-305D Cold Head
- F-40L/H or FA-40L/H Compressor
- Helium Gas Lines – 10 m (33 ft.)
- Cold Head Cable – 10 m (33 ft.)
- Power Cable – 3-6 m (10-20 ft.)² or 2-8 m (6-27 ft.)³
- Tool Kit

¹Lowest temperature and cooldown time are for reference only.

²With F-40L and FA-40L

³With F-40H and FA-40H

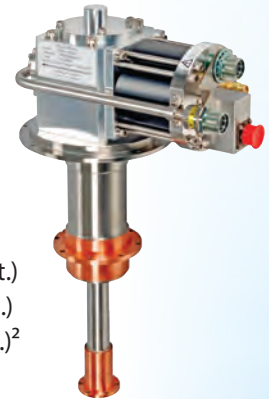

RDK-305D Cold Head Capacity Map (50 Hz)

With FA-40 Compressor and 10 m (35 ft.) Helium Gas Lines

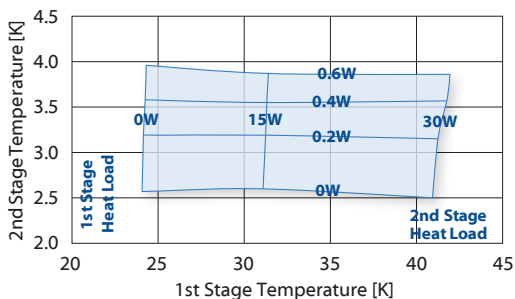

RDK-305D Cold Head Capacity Map (60 Hz)

With FA-40 Compressor and 10 m (35 ft.) Helium Gas Lines

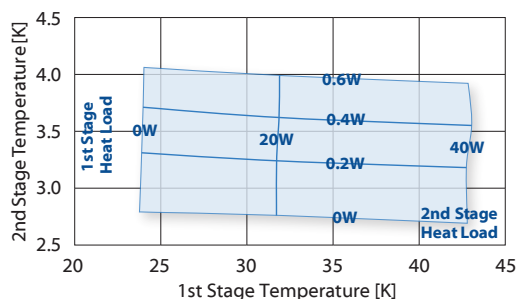

Note: Capacity maps for reference only

RDK-205D 4K Cryocooler Series

Performance Specifications

Power Supply	50Hz	60 Hz
2 nd Stage Capacity	0.5 W @ 4.2 K	
1 st Stage Capacity	10 W @ 50 K	13 W @ 50 K
Minimum Temperature ¹	<3.5 K	
Cooldown Time to 4.2 K ¹	<90 Minutes	
Weight	14.0 kg (30.9 lbs.)	
Dimensions (HxWxD)	512 x 180 x 294 mm (20.2 x 7.1 x 11.6 in.)	
Maintenance	10,000 Hours	
Regulatory Compliance	UL/CE, RoHS	

Standard Scope of Supply

- RDK-205D Cold Head
- CKW-21A, F-40L/H or FA-40L/H Compressor
- Helium Gas Lines – 10 m (32 ft.)
- Cold Head Cable – 10 m (32 ft.)
- Power Cable – 10 m (33 ft.)², 3-6 m (10-20 ft.)³ or 2-8 m (6-27 ft.)⁴
- Hose Nipples²
- Tool Kit

¹ Lowest temperature and cooldown time are for reference only.

² With CKW-21A

³ With F-40L and FA-40L

⁴ With F-40H and FA-40H

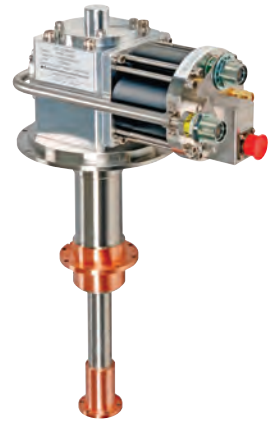

RDK-205D Cold Head Capacity Map (50 Hz)

With F-40 Compressor and 10 m (33 ft.) Helium Gas Lines

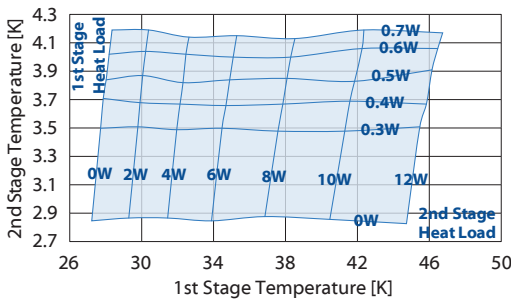

RDK-205D Cold Head Capacity Map (60 Hz)

With F-40 Compressor and 10 m (33 ft.) Helium Gas Lines

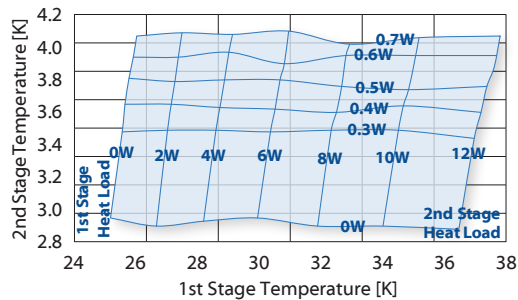

RDK-408D2 4K Cryocooler Series

Performance Specifications

Power Supply	50Hz	60 Hz
2 nd Stage Capacity	1.0 W @ 4.2 K	
1 st Stage Capacity	40 W @ 43 K	50 W @ 43 K
Minimum Temperature ¹	<3.5 K	
Cooldown Time to 4.2 K ¹	<60 Minutes	
Weight	18.0 kg (39.7 lbs.)	
Dimensions (HxWxD)	557 x 180 x 294 mm (21.9 x 7.1 x 11.6 in.)	
Maintenance	10,000 Hours	
Regulatory Compliance	UL/CE, RoHS	

Standard Scope of Supply

- RDK-408D2 Cold Head
- F-50L/H, F-70L/H, CSA-71A or FA-70L/H Compressor
- Helium Gas Lines – 6 m (20 ft.)^{2,3,4,5}; or 10 m (33 ft.) [IDU] + 10 m (33 ft.), 20 m (66 ft.) or 30 m (99 ft.) [ODU]⁶
- Cold Head Cable – 6-20 m (20-66 ft.)
- Power Cable – 5 m (16.5 ft.)^{2,5}; 3-6 m (10-20 ft.)³; 2-8 m (6-27 ft.)⁴; or 5 m (16.5 ft.) [IDU] + 10 m (33 ft.), 20 m (66 ft.) or 30 m (99 ft.) [ODU]⁶
- Hose Nipples²
- Tool Kit

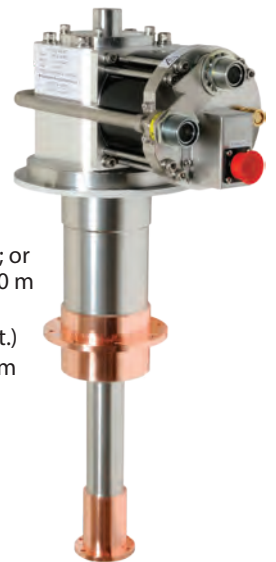

RDK-408D2 Cold Head Capacity Map (50 Hz)

With F-50 Compressor and 6 m (20 ft.) Helium Gas Lines

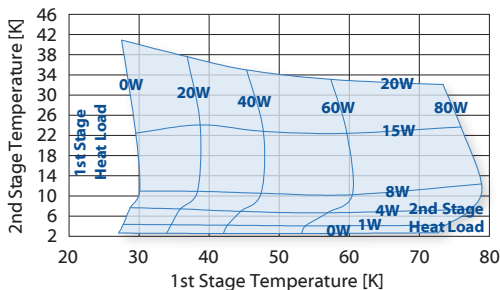

RDK-408D2 Cold Head Capacity Map (60 Hz)

With F-50 Compressor and 6 m (20 ft.) Helium Gas Lines

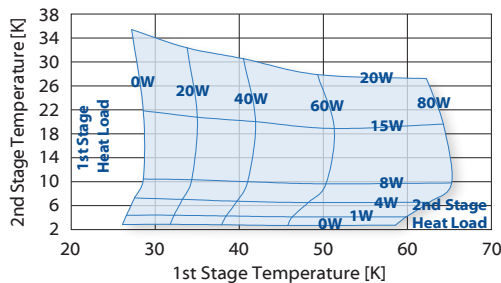

¹ Lowest temperature and cooldown time are for reference only.

² With F-50

³ With F-70L

⁴ With F-70H

⁵ With CSA-71A

⁶ With FA-70

RDE-412D4 4K Cryocooler Series

Performance Specifications

Power Supply	50Hz	60 Hz
2 nd Stage Capacity ¹	1.25 W @ 4.2 K	
1 st Stage Capacity ¹	53 W @ 43 K	60 W @ 43 K
Minimum Temperature ²	<3.5 K	
Cooldown Time to 4.2 K ²	<60 Minutes	
Weight	20.0 kg (44.1 lbs.)	
Dimensions (HxWxD)	554 x 180 x 306 mm (21.8 x 7.1 x 12.0 in.)	
Maintenance	10,000 Hours	
Regulatory Compliance	UL/CE, RoHS	

Standard Scope of Supply

- RDE-412D4 Cold Head
- F-40L/H, F-50L/H, F-50SL/H, F-70L/H, FA-40L/H or CSA-71A Compressor
- Helium Gas Lines – 20 m (65 ft.)^{3,6,7} or 6 m (20 ft.) with Buffer Tank^{4,5}
- Cold Head Cable – 20 m (65 ft.)³ or 6-20 m (20-66 ft.)^{4,5,6,7}
- Power Cable – 3 m (10 ft.)³, 5 m (16.5 ft.)^{4,5}, 3-6 m (10-20 ft.)⁶ or 2-8 m (6-27 ft.)⁷
- Hose Nipples^{3,4}
- Tool Kit



RDE-412D4 Cold Head Capacity Map (50 Hz)

With F-50 Compressor and 20 m (66 ft.) Helium Gas Lines

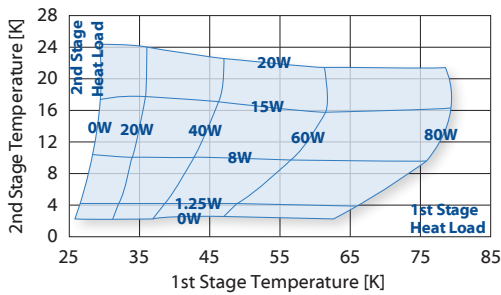

RDE-412D4 Cold Head Capacity Map (60 Hz)

With F-50 Compressor and 20 m (66 ft.) Helium Gas Lines

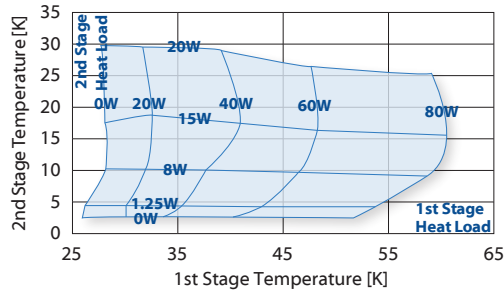

¹ Reduced capacities when operated with F-40 or FA-40 Compressors.

² Lowest temperature and cooldown time are for reference only.

³ With F-40 and FA-40

⁴ With F-50

⁵ With CSA-71A

⁶ With F-70L

⁷ With F-70H

RDK-415D 4K Cryocooler Series

Performance Specifications

Power Supply	50Hz	60 Hz
2 nd Stage Capacity	1.5 W @ 4.2 K	
1 st Stage Capacity	35 W @ 50 K	45 W @ 50 K
Minimum Temperature ¹	<3.5 K	
Cooldown Time to 4.2 K ¹	<60 Minutes	
Weight	18.5 kg (40.8 lbs.)	
Dimensions (HxWxD)	557 x 180 x 294 mm (21.9 x 7.1 x 11.6 in.)	
Maintenance	10,000 Hours	
Regulatory Compliance	UL/CE, RoHS	

Standard Scope of Supply

- RDK-415D Cold Head
- F-50L/H, F-70L/H, CSA-71A or FA-70L/H Compressor
- Helium Gas Lines – 20 m (66 ft.)^{2,3,4,5}; 6 m (20 ft.) with Buffer Tank^{2,5}; or 10 m (33 ft.) [IDU] + 10 m (33 ft.), 20 m (66 ft.) or 30 m (99 ft.) [ODU]⁶
- Cold Head Cable – 6-20 m (20-66 ft.)
- Power Cable – 5 m (16.5 ft.)^{2,5}; 3-6 m (10-20 ft.)³; 2-8 m (6-27 ft.)⁴; or 5 m (16.5 ft.) [IDU] + 10 m (33 ft.), 20 m (66 ft.) or 30 m (99 ft.) [ODU]⁶
- Hose Nipples²
- Tool Kit

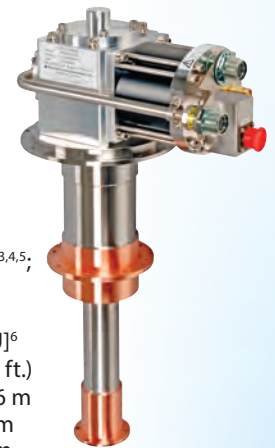

RDK-415D Cold Head Capacity Map (50 Hz)

With F-50 Compressor and 20 m (66 ft.) Helium Gas Lines

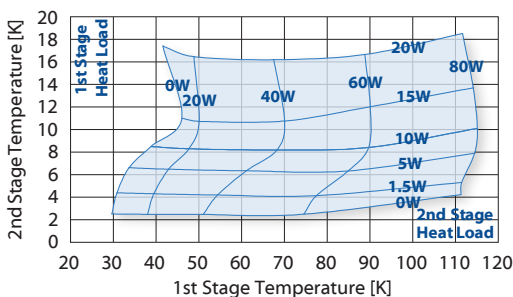

RDK-415D Cold Head Capacity Map (60 Hz)

With F-50 Compressor and 20 m (66 ft.) Helium Gas Lines

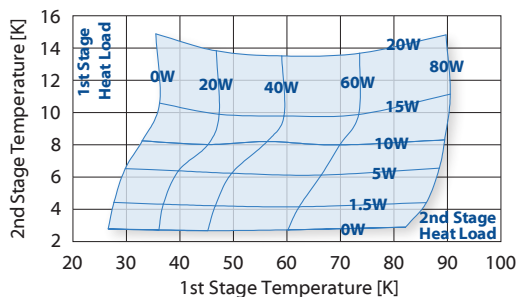

¹ Lowest temperature and cooldown time are for reference only.

² With F-50

³ With F-70L

⁴ With F-70H

⁵ With CSA-71A

⁶ With FA-70

RDE-418D4 4K Cryocooler Series

Performance Specifications

Power Supply	50Hz	60 Hz
2nd Stage Capacity	1.8 W @ 4.2 K	2.0 W @ 4.2 K
1st Stage Capacity	42 W @ 50 K	50 W @ 50 K
Minimum Temperature ¹	<3.5 K	
Cooldown Time to 4.2 K ¹	<60 Minutes	
Weight	20.0 kg (44.1 lbs.)	
Dimensions (HxWxD)	554 x 180 x 306 mm (21.8 x 7.1 x 12.0 in.)	
Maintenance	10,000 Hours	
Regulatory Compliance	UL/CE, RoHS	

Standard Scope of Supply

- RDE-418D4 Cold Head
- F-50L/H, F-50SL/H or F-70L/H Compressor
- Helium Gas Lines – 20 m (65 ft.) or 6 m (20 ft.) with Buffer Tank
- Cold Head Cable – 6-20 m (20-66 ft.)², 20 m (66 ft.)³
- Power Cable – 2 m (6 ft.)³, 5 m (16.5 ft.)²
- Hose Nipples
- Tool Kit



¹ Lowest temperature and cooldown time are for reference only.

² With F-50

³ With F-70

RDE-418D4 Cold Head Capacity Map (50 Hz)

With F-50 Compressor and 20 m (66 ft.) Helium Gas Lines

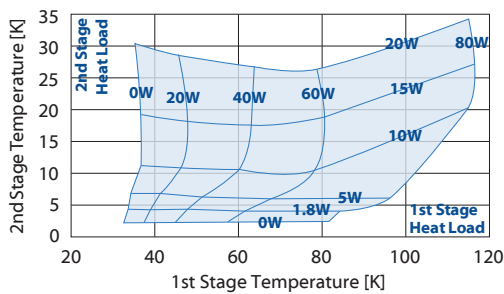

RDE-418D4 Cold Head Capacity Map (60 Hz)

With F-50 Compressor and 20 m (66 ft.) Helium Gas Lines

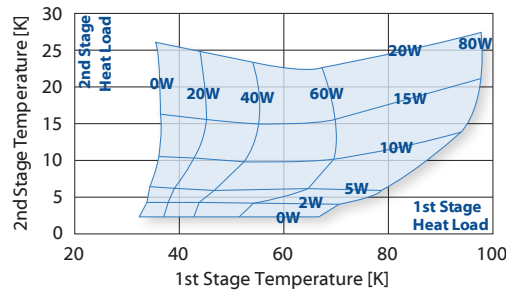

SHI Cryogenics Group Locations Asia

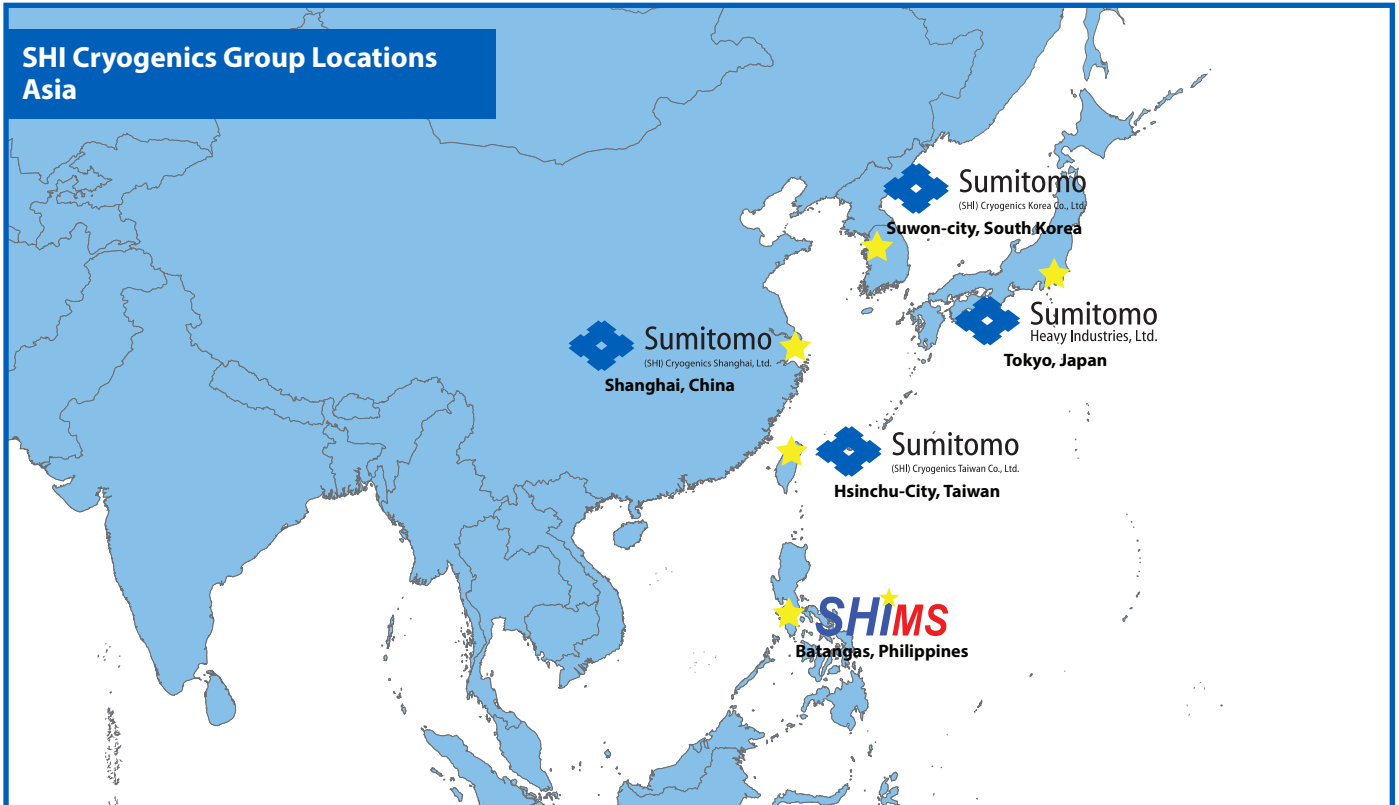

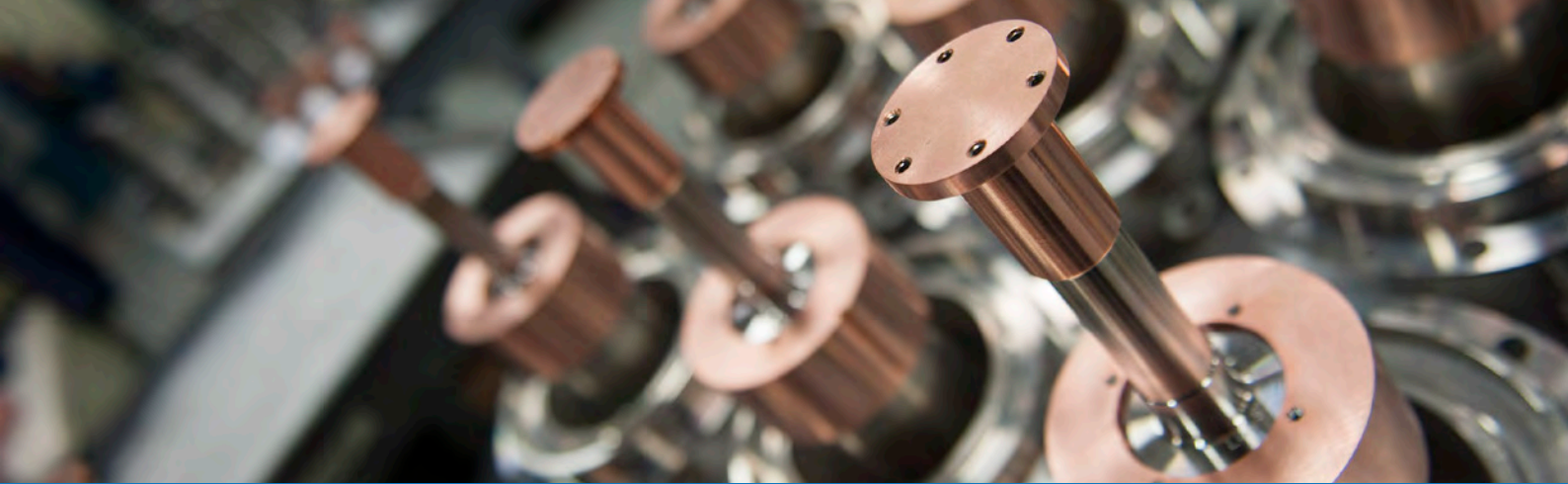

10K Cryocooler Series

- SHI's 10K Gifford-McMahon Cryocoolers are versatile, closed-cycle systems, with the CH series featuring Displex® technology.
- Displex cryocoolers have been recognized as the industry standard since we developed the technology over 40 years ago.
- Its original pneumatic drive, which limits the number of wear parts in the refrigerator, combined with state-of-the-art design features, results in superior performance and low maintenance costs.
- SHI's 10K Cryocoolers have proven reliability in thousands of applications, including MRI, cryopumping, research and other custom low temperature applications.



CH-202



CH-204



CH-208R

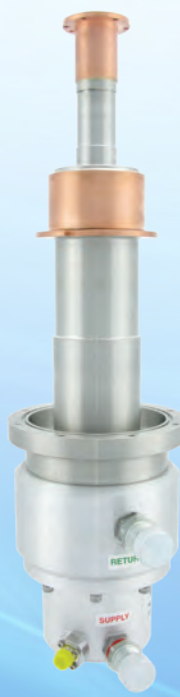

CH-208L



CH-210



RDK-408S

CH-202 10K Cryocooler Series

Performance Specifications

Power Supply	50Hz	60 Hz
2 nd Stage Capacity	2.0 W @ 20 K	2.5 W @ 20 K
1 st Stage Capacity	7.3 W @ 77 K	8.8 W @ 77 K
Minimum Temperature ¹	10 K	
Cooldown Time to 20 K ¹	75 Minutes	65 Minutes
Weight	7.2 kg (16.0 lbs.)	
Dimensions (HxD) ²	468 x ø133 mm (18.4 x ø5.3 in.)	
Maintenance	13,000 Hours	
Regulatory Compliance	CE	

Standard Scope of Supply

- CH-202 Cold Head
- HC-4E or Zephyr® Compressor
- Helium Gas Lines – 3-25 m (10-82 ft.)
- Cold Head Cable – 3.5-15 m (11-50 ft.)
- Tool Kit

¹Lowest temperature and cooldown time are for reference only.

²With standard flat warm flange. (Available in other warm flange interfaces.)



CH-202 Cold Head Capacity Map (50 Hz)

With HC-4E1 Compressor and 3 m (10 ft.) Helium Gas Lines

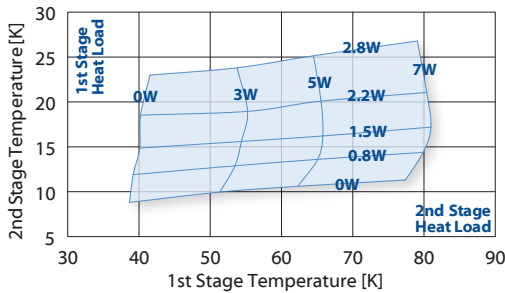

CH-202 Cold Head Capacity Map (60 Hz)

With HC-4E1 Compressor and 3 m (10 ft.) Helium Gas Lines

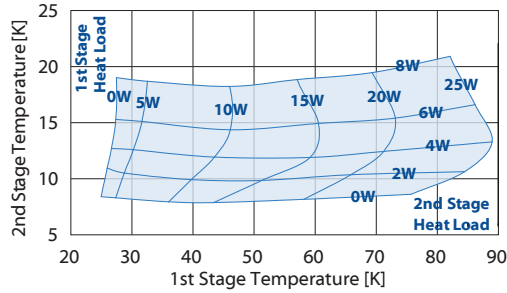

CH-204 10K Cryocooler Series

Performance Specifications

Power Supply	50Hz	60 Hz
2 nd Stage Capacity	7.5 W @ 20 K	9.0 W @ 20 K
1 st Stage Capacity	13.5 W @ 80 K	16.2 W @ 80 K
Minimum Temperature ¹	10 K	
Cooldown Time to 20 K ¹	35 Minutes	30 Minutes
Weight	7.8 kg (17.2 lbs.)	
Dimensions (HxD) ²	468 x ø133 mm (18.4 x ø5.3 in.)	
Maintenance	13,000 Hours	
Regulatory Compliance	CE	

Standard Scope of Supply

- CH-204 Cold Head
- HC-4E, HC-8E, F-70L/H or Zephyr® Compressor³
- Helium Gas Lines – 3-25 m (10-82 ft.)
- Cold Head Cable – 3.5-15 m (11-50 ft.)⁴, 3-18 m (10-60 ft.)⁵ or 3-20 m (10-66 ft.)^{6,7}
- Power Cable – 3-6 m (10-20 ft.)⁶ or 2-8 m (6-27 ft.)⁷
- Tool Kit

¹Lowest temperature and cooldown time are for reference only.

²With standard flat warm flange. (Available in other warm flange interfaces.)



CH-204 Cold Head Capacity Map (50/60 Hz)

With HC-4E2 Compressor and 3 m (10 ft.) Helium Gas Lines

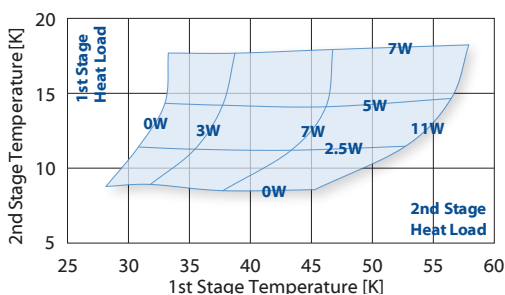

CH-204 Cold Head Capacity Map (60 Hz)

With HC-4E2 Compressor and 3 m (10 ft.) Helium Gas Lines

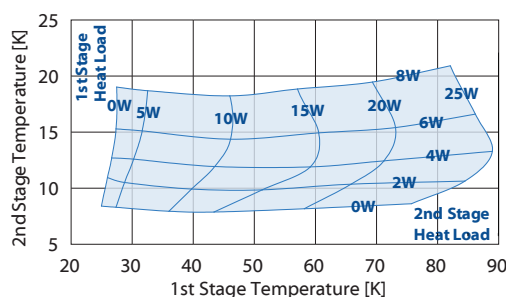

³ Up to two (2) cold heads can be operated with the F-70 Compressor.

⁴ With HC-4E or Zephyr®

⁵ With HC-8E

⁶ With F-70L

⁷ With F-70H

CH-208R 10K Cryocooler Series

Performance Specifications

Power Supply	50Hz	60 Hz
2nd Stage Capacity	6.0 W @ 20 K	7.5 W @ 20 K
1st Stage Capacity	65 W @ 77 K	80 W @ 77 K
Minimum Temperature¹	10 K	
Cooldown Time to 20 K¹	55 Minutes	45 Minutes
Weight	11.6 kg (25.6 lbs.)	
Dimensions (HxD)	551 x ø156 mm (21.7 x ø6.1 in.)	
Maintenance	13,000 Hours	
Regulatory Compliance	CE	

Standard Scope of Supply

- CH-208R Cold Head
- HC-8E or F-70L/H Compressor
- Helium Gas Lines – 3-25 m (10-82 ft.)
- Cold Head Cable – 3-18 m (10-60 ft.)² or 3-20 m (10-66 ft.)^{3,4}
- Power Cable – 3-6 m (10-20 ft.)³ or 2-8 m (6-27 ft.)⁴
- Tool Kit

¹Lowest temperature and cooldown time are for reference only.

²With HC-8E

³With F-70L

⁴With F-70H



CH-208R Cold Head Capacity Map (50 Hz)

With HC-8E4 Compressor and 3 m (10 ft.) Helium Gas Lines

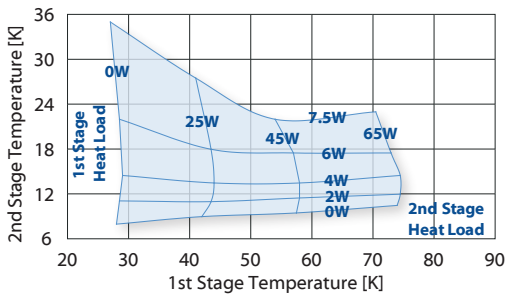

CH-208R Cold Head Capacity Map (60 Hz)

With HC-8E4 Compressor and 3 m (10 ft.) Helium Gas Lines

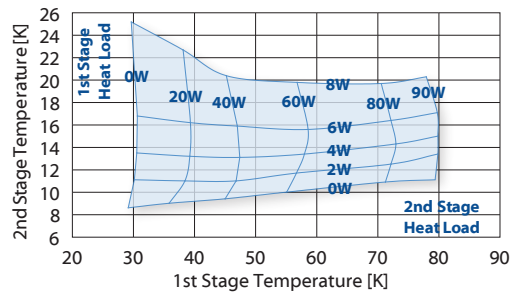

CH-208L 10K Cryocooler Series

Performance Specifications

Power Supply	50Hz	60 Hz
2nd Stage Capacity	8.0 W @ 20 K	10.0 W @ 20 K
1st Stage Capacity	28 W @ 77 K	35 W @ 77 K
Minimum Temperature¹	10 K	
Cooldown Time to 20 K¹	50 Minutes	40 Minutes
Weight	11.8 kg (26.0 lbs.)	
Dimensions (HxD)	551 x ø156 mm (21.7 x ø6.1 in.)	
Maintenance	13,000 Hours	
Regulatory Compliance	CE	

Standard Scope of Supply

- CH-208L Cold Head
- HC-8E or F-70L/H Compressor
- Helium Gas Lines – 3-25 m (10-82 ft.)
- Cold Head Cable – 3-18 m (10-60 ft.)² or 3-20 m (10-66 ft.)^{3,4}
- Power Cable – 3-6 m (10-20 ft.)³ or 2-8 m (6-27 ft.)⁴
- Tool Kit

¹Lowest temperature and cooldown time are for reference only.

²With HC-8E

³With F-70L

⁴With F-70H



CH-208L Cold Head Capacity Map (50 Hz)

With HC-8E4 Compressor and 3 m (10 ft.) Helium Gas Lines

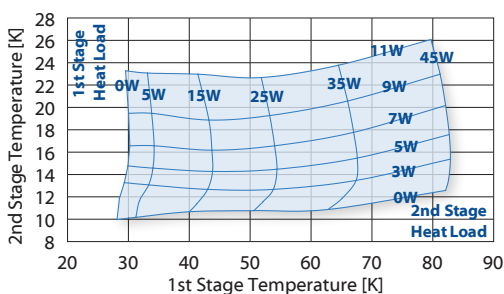

CH-208L Cold Head Capacity Map (60 Hz)

With HC-8E4 Compressor and 3 m (10 ft.) Helium Gas Lines

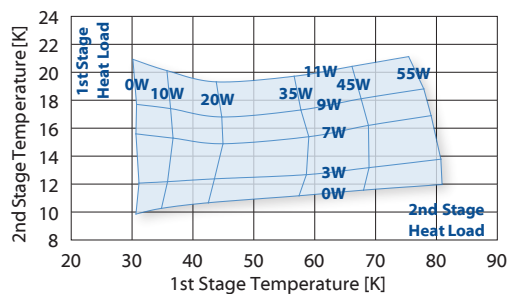

CH-210 10K Cryocooler Series

Performance Specifications

Power Supply	50Hz	60 Hz
2 nd Stage Capacity	6.0 W @ 20 K	7.0 W @ 20 K
1 st Stage Capacity	110 W @ 77 K	120 W @ 77 K
Minimum Temperature ¹	10 K	
Cooldown Time to 20 K ¹	60 Minutes	50 Minutes
Weight	13.8 kg (30.4 lbs.)	
Dimensions (HxD)	500 x ø133 mm (19.7 x ø5.2 in.)	
Maintenance	13,000 Hours	
Regulatory Compliance	CE, UL	

Standard Scope of Supply

- CH-210 Cold Head
- F-70L/H Compressor
- Helium Gas Lines – 3-25 m (10-82 ft.)
- Cold Head Cable – 3-20 m (10-66 ft.)
- Power Cable – 3-6 m (10-20 ft.)² or 2-8 m (6-27 ft.)³
- Tool Kit

¹Lowest temperature and cooldown time are for reference only.

²With F-70L

³With F-70H



CH-210 Cold Head Capacity Map (50 Hz)

With F-70 Compressor and 13.5 m (44 ft.) Helium Gas Lines

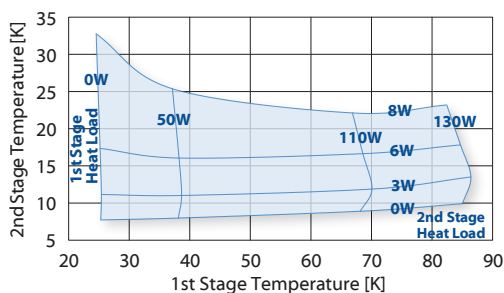

CH-210 Cold Head Capacity Map (60 Hz)

With F-70 Compressor and 13.5 m (44 ft.) Helium Gas Lines

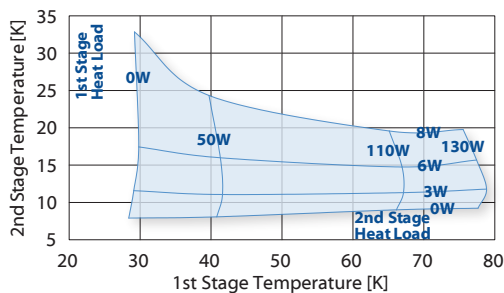

RDK-408S 10K Cryocooler Series

Performance Specifications

Power Supply	50Hz	60 Hz
2 nd Stage Capacity	5.4 W @ 10 K	6.3 W @ 10 K
1 st Stage Capacity	30 W @ 45 K	35 W @ 45 K
Minimum Temperature ¹	<7 K	
Cooldown Time to 10 K ¹	<60 Minutes	
Weight	17.2 kg (37.9 lbs.)	
Dimensions (HxWxD)	520 x 180 x 294 mm (20.5 x 7.1 x 11.6 in.)	
Maintenance	10,000 Hours	
Regulatory Compliance	UL/CE, RoHS	

Standard Scope of Supply

- RDK-408S Cold Head
- F-50L/H, CSA-71A or FA-70L/H Compressor
- Helium Gas Lines – 6 m (20 ft.)^{2,3}; or 10 m (33 ft.) [IDU] + 10 m (33 ft.), 20 m (66 ft.) or 30 m (99 ft.) [ODU]⁴
- Cold Head Cable – 6 m (20 ft.)^{2,3} or 6-20 m (20-66 ft.)⁴
- Power Cable – 5 m (16.5 ft.)^{2,3}; or 5 m (16.5 ft.) [IDU] + 10 m (33 ft.), 20 m (66 ft.) or 30 m (99 ft.) [ODU]⁴
- Hose Nipples²
- Tool Kit



RDK-408S Cold Head Capacity Map (50 Hz)

With F-50 Compressor and 6 m (20 ft.) Helium Gas Lines

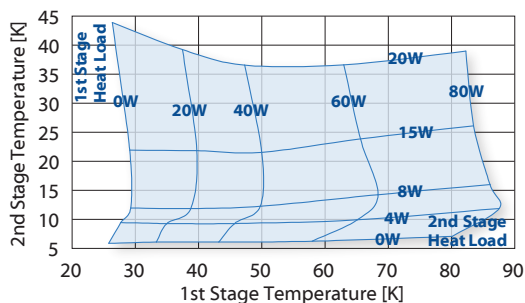

RDK-408S Cold Head Capacity Map (60 Hz)

With F-50 Compressor and 6 m (20 ft.) Helium Gas Lines

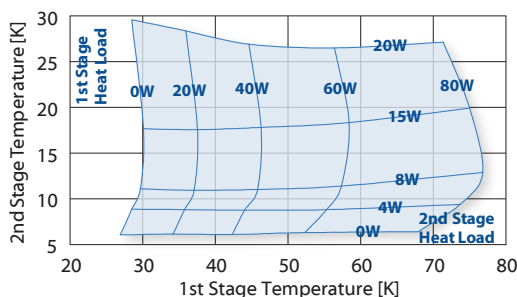

¹Lowest temperature and cooldown time are for reference only.

²With F-50

³With CSA-71A

⁴With FA-70



Pulse Tube Series

- SHI's 4K Pulse Tube Cryocoolers embody leading-edge technology, and provide low vibration and high reliability with low maintenance requirements.
- They are uniquely designed with no moving parts inside the cold head.
- In addition, they feature an optional separated valve unit to further reduce vibration, enable operation in higher magnetic fields and ease maintenance requirements.
- SHI Pulse Tube Cryocoolers provide a stable low-temperature solution for sensitive measurement and analytical applications.



RP-062B 4K Pulse Tube Series

Performance Specifications

Power Supply	50Hz	60 Hz
2 nd Stage Capacity	0.5 W @ 4.2 K	
1 st Stage Capacity	30 W @ 65 K	
Minimum Temperature ¹	<3.0 K	
Cooldown Time to 4.2 K ¹	<100 Minutes	<90 Minutes
Weight	23.2 kg (51.1 lbs.)	
Dimensions (HxWxD)	604 x 336 x 190 mm (23.8 x 13.2 x 7.5 in.)	
Maintenance	20,000 Hours	
Regulatory Compliance	CE, UL	

Standard Scope of Supply

- RP-062B Cold Head
- F-50L/H Compressor
- Helium Gas Lines – 20 m (66 ft.) or 6 m (20 ft.) with Buffer Tank
- Cold Head Cable – 20 m (66 ft.)
- Power Cable – 5 m (16.5 ft.)
- Hose Nipples
- Power Box
- Filter Unit with 1 m (3 ft.) Helium Gas Line
- Tool Kit

¹Lowest temperature and cooldown time are for reference only.



RP-062B Cold Head Capacity Map (50 Hz)

With F-50 Compressor and 20 m (66 ft.) Helium Gas Lines

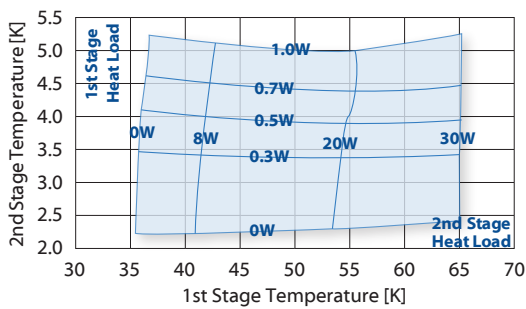

RP-062B Cold Head Capacity Map (60 Hz)

With F-50 Compressor and 20 m (66 ft.) Helium Gas Lines

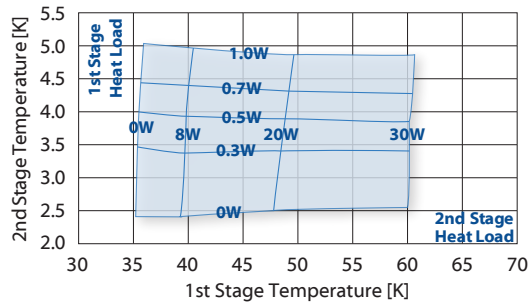

RP-062BS 4K Pulse Tube Series

Performance Specifications

Power Supply	50Hz	60 Hz
2 nd Stage Capacity	0.4 W @ 4.2 K	
1 st Stage Capacity	25 W @ 65 K	
Minimum Temperature ¹	<3.0 K	
Cooldown Time to 4.2 K ¹	<100 Minutes	<90 Minutes
Weight	23.5 kg (51.8 lbs.)	
Dimensions (HxWxD)	599 x 1271 x 190 mm (23.6 x 50.0 x 7.5 in.)	
Maintenance	20,000 Hours	
Regulatory Compliance	CE, UL	

Standard Scope of Supply

- RP-062BS Cold Head
- F-50L/H Compressor
- Helium Gas Lines – 20 m (66 ft.) or 6 m (20 ft.) with Buffer Tank
- Cold Head Cable – 20 m (66 ft.)
- Power Cable – 5 m (16.5 ft.)
- Hose Nipples
- Power Box
- Filter Unit with 1 m (3 ft.) Helium Gas Line
- Tool Kit



RP-062BS Cold Head Capacity Map (50 Hz)

With F-50 Compressor and 20 m (66 ft.) Helium Gas Lines

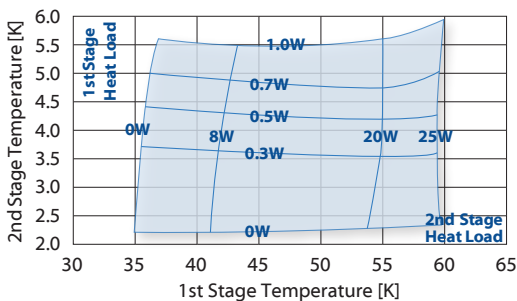

RP-062BS Cold Head Capacity Map (60 Hz)

With F-50 Compressor and 20 m (66 ft.) Helium Gas Lines

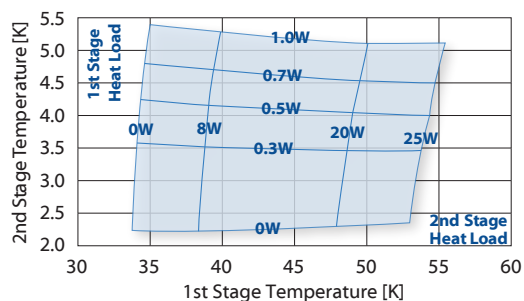

¹Lowest temperature and cooldown time are for reference only.

RP-082B2 4K Pulse Tube Series

Performance Specifications

Power Supply	50Hz	60 Hz
2 nd Stage Capacity ¹	1.0 W @ 4.2 K	
1 st Stage Capacity ¹	40 W @ 45 K	
Minimum Temperature ²	<3.0 K	
Cooldown Time to 4.2 K ²	<80 Minutes	
Weight	25.0 kg (55.1 lbs.)	
Dimensions (HxWxD)	557 x 194 x 339 mm (21.9 x 7.6 x 13.3 in.)	
Maintenance	20,000 Hours	
Regulatory Compliance	CE, UL, RoHS	

Standard Scope of Supply

- RP-082B2 Cold Head
- F-70LP/H or FA-70L/H Compressor
- Helium Gas Lines – 20 m (66 ft.)^{3,4} or 10 m + 10 m (33 ft. + 33ft.) [IDU + ODU]⁵
- Cold Head Cable – 20 m (66 ft.)
- Power Cable – 5 m (16.5 ft.)³; 2 m (6 ft.)⁴; or 5 m + 10 m (16.5 ft. + 33 ft.) [IDU + ODU]⁵
- Hose Nipples^{3,4}
- Filter Unit with 1 m (3 ft.) Helium Gas Line
- Tool Kit

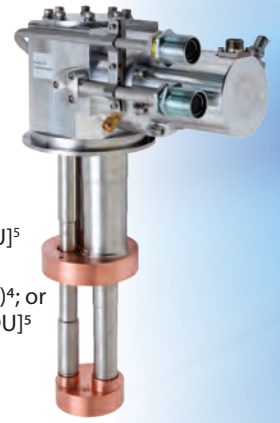

RP-082B2 Cold Head Capacity Map (50 Hz)

With F-70 Compressor and 20 m (66 ft.) Helium Gas Lines

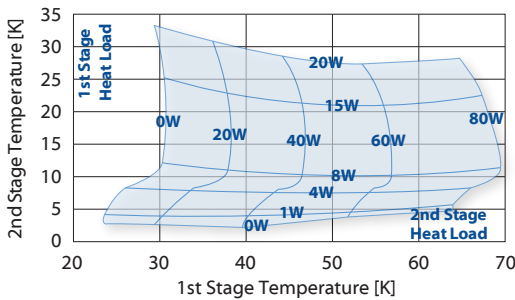

RP-082B2 Cold Head Capacity Map (60 Hz)

With F-70 Compressor and 20 m (66 ft.) Helium Gas Lines

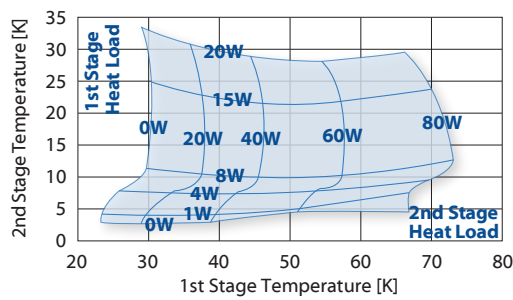

- ¹ Reduced capacities when operated with FA-70 Compressor.
- ² Lowest temperature and cooldown time are for reference only.
- ³ With F-70LP
- ⁴ With F-70H
- ⁵ With FA-70

RP-082B2S 4K Pulse Tube Series

Performance Specifications

Power Supply	50Hz	60 Hz
2 nd Stage Capacity ¹	0.9 W @ 4.2 K	
1 st Stage Capacity ¹	35 W @ 45 K	
Minimum Temperature ²	<3.0 K	
Cooldown Time to 4.2 K ²	<90 Minutes	
Weight	26.0 kg (57.3 lbs.)	
Dimensions (HxWxD)	647 x 180 x 1354 mm (25.5 x 7.1 x 53.3 in.)	
Maintenance	20,000 Hours	
Regulatory Compliance	CE, UL, RoHS	

Standard Scope of Supply

- RP-082B2S Cold Head
- F-70LP/H or FA-70L/H Compressor
- Helium Gas Lines – 20 m (66 ft.)^{3,4} or 10 m + 10 m (33 ft. + 33 ft.) [IDU + ODU]⁵
- Cold Head Cable – 20 m (66 ft.)
- Power Cable – 5 m (16.5 ft.)³; 2 m (6 ft.)⁴; or 5 m + 10 m (16.5 ft. + 33 ft.) [IDU + ODU]⁵
- Hose Nipples^{3,4}
- Filter Unit with 1 m (3 ft.) Helium Gas Line
- Tool Kit

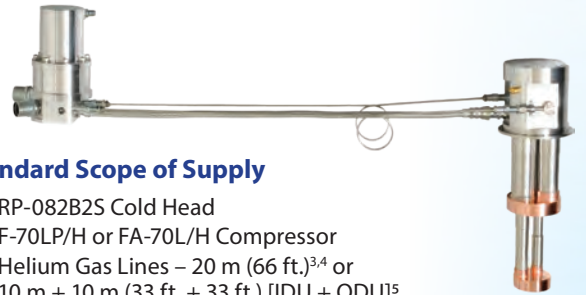

RP-082B2S Cold Head Capacity Map (50 Hz)

With F-70 Compressor and 20 m (66 ft.) Helium Gas Lines

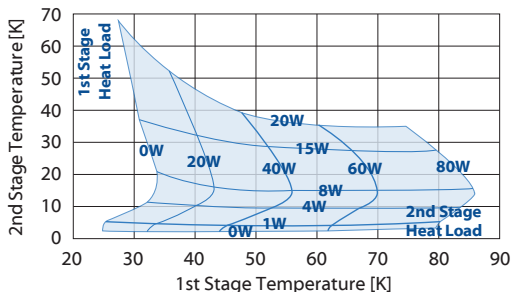

RP-082B2S Cold Head Capacity Map (60 Hz)

With F-70 Compressor and 20 m (66 ft.) Helium Gas Lines

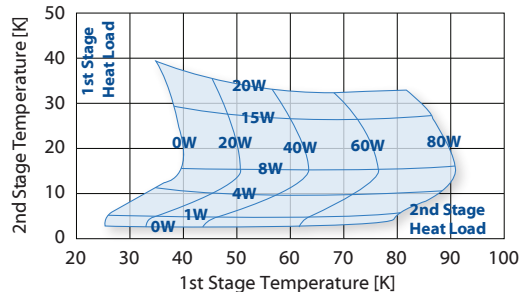

- ¹ Reduced capacities when operated with FA-70 Compressor.
- ² Lowest temperature and cooldown time are for reference only.
- ³ With F-70LP
- ⁴ With F-70H
- ⁵ With FA-70

RP-182B2S 4K Pulse Tube Series

Performance Specifications

Power Supply	50Hz	60 Hz
2 nd Stage Capacity	1.5 W @ 4.2 K	
1 st Stage Capacity	36 W @ 48 K	
Minimum Temperature ¹	<2.8 K	
Cooldown Time to 4.2 K ¹	<60 Minutes	
Weight	28.0 kg (61.7 lbs.)	
Dimensions (HxD)	539 x ø187 mm (21.2 x ø7.4 in.)	
Maintenance	20,000 Hours	
Regulatory Compliance	CE, UL/cUL, RoHS	

Standard Scope of Supply

- RP-182B2S Cold Head
- F-100L/H Compressor
- Helium Gas Lines – 20 m (66 ft.)
- Cold Head Cable – 20 m (66 ft.)
- Power Cable – 20 m (66 ft.)
- Hose Nipples
- Tool Kit

¹Lowest temperature and cooldown time are for reference only.

IMPORTANT: The SRP-182B2S-F100L cannot be installed in Japan, due to Japanese high pressure gas laws. For details, please contact SHI. Please follow all local laws related to high pressure gas regulation.

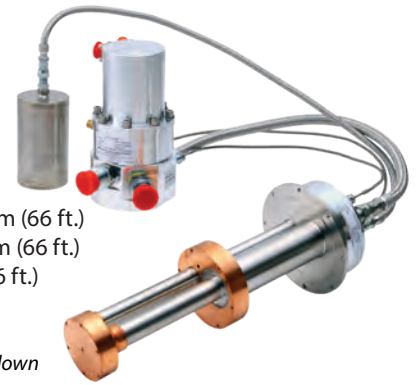

RP-182B2S Cold Head Capacity Map (50 Hz)

With F-100 Compressor and 20 m (66 ft.) Helium Gas Lines

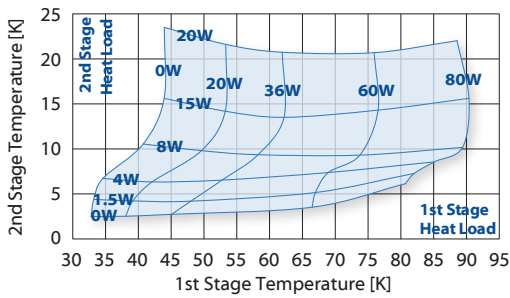

RP-182B2S Cold Head Capacity Map (60 Hz)

With F-100 Compressor and 20 m (66 ft.) Helium Gas Lines

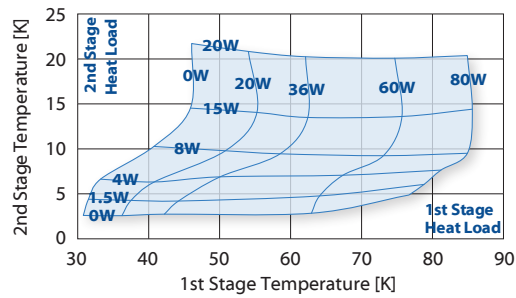

SHI Cryogenics Group Locations United States

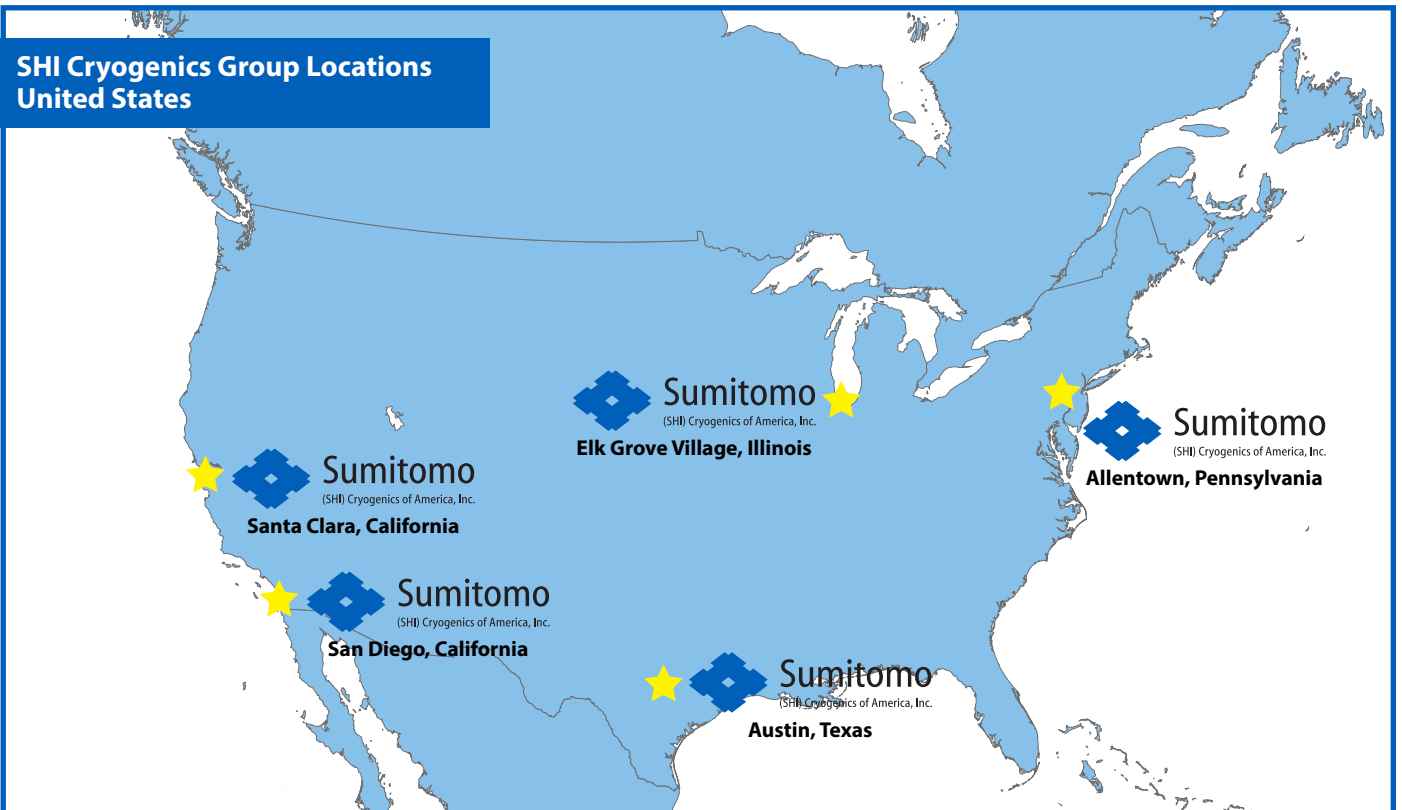



Specialty Cryocoolers

- In addition to our standard 4K, 10K and Pulse Tube Cryocoolers, SHI Cryogenics Group offers several cryocooler models designed for specialty research applications.
- These models cover a wide range of options, and include a 6.5K Gifford-McMahon Cryocooler as well as several single-stage Cryocoolers.
- Like other Cryocooler products, all Specialty Cryocoolers are backed by SHI's worldwide sales, service and support network.



CH-204-N 6.5K Cryocooler Series

Performance Specifications

Power Supply	50Hz	60 Hz
2 nd Stage Capacity	2.5 W @ ≤10 K	3.0 W @ ≤10 K
Minimum Temperature ¹	6.5 K	
Cooldown Time to 6.5 K ¹	40 Minutes	35 Minutes
Weight	7.8 kg (17.2 lbs.)	
Dimensions (HxD) ²	468 x ø133 mm (18.4 x ø5.3 in.)	
Maintenance	13,000 Hours	
Regulatory Compliance	CE	

CH-204-N Cold Head Capacity Map (50/60 Hz)

With HC-4E1 Compressor and 3 m (10 ft.) Helium Gas Lines

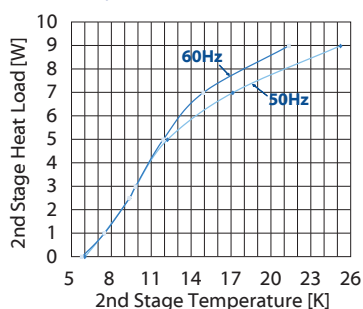

Standard Scope of Supply

- CH-204-N Cold Head
- HC-4E, HC-8E, F-70L/H or Zephyr® Compressor³
- Helium Gas Lines – 3-25 m (10-82 ft.)
- Cold Head Cable – 3.5-15 m (11-50 ft.)⁴, 3-18 m (10-60 ft.)⁵ or 3-20 m (10-66 ft.)^{6,7}
- Power Cable – 3-6 m (10-20 ft.)⁶ or 2-8 m (6-27 ft.)⁷
- Tool Kit

¹Lowest temperature and cooldown time are for reference only.

²With standard flat warm flange. (Available in other warm flange interfaces.)

³Up to two (2) cold heads can be operated with the F-70 Compressor.

⁴With HC-4E or Zephyr®

⁵With HC-8E

⁶With F-70L

⁷With F-70H



CH-210-N 10K Cryocooler Series

Performance Specifications

Power Supply	60Hz
2 nd Stage Capacity	3.0 W @ 10 K
1 st Stage Capacity	20 W @ 35 K
Minimum Temperature ¹	10 K
Cooldown Time to 10 K ¹	60 Minutes
Weight	13.8 kg (30.4 lbs.)
Dimensions (HxD)	502 x ø190 mm (19.8 x ø7.5 in.)
Maintenance	13,000 Hours
Regulatory Compliance	CE

CH-210-N Cold Head Capacity Map (60 Hz)

With F-70 Compressor and 6 m (20 ft.) Helium Gas Lines

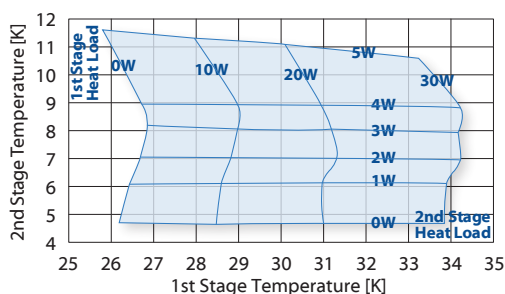

Standard Scope of Supply

- CH-210-N Cold Head
- F-70L/H Compressor
- Helium Gas Lines – 3-25 m (10-82 ft.)
- Cold Head Cable – 3-20 m (10-66 ft.)
- Power Cable – 3-6 m (10-20 ft.)² or 2-8 m (6-27 ft.)³
- Tool Kit

¹Lowest temperature and cooldown time are for reference only.

²With F-70L

³With F-70H



CH-210L 10K Cryocooler Series

Performance Specifications

Power Supply	50Hz	60 Hz
2 nd Stage Capacity	9.5 W @ 20 K	11 W @ 20 K
1 st Stage Capacity	75 W @ 60 K	90 W @ 60 K
Minimum Temperature ¹	10 K	
Cooldown Time to 20 K ¹	<60 Minutes	
Weight	12.1 kg (26.7 lbs.)	
Dimensions (HxD)	502 x ø190 mm (19.8 x ø7.5 in.)	
Maintenance	13,000 Hours	
Regulatory Compliance	CE	

Standard Scope of Supply

- CH-210L Cold Head
- F-70L/H Compressor
- Helium Gas Lines – 3-25 m (10-82 ft.)
- Cold Head Cable – 3-20 m (10-66 ft.)
- Power Cable – 3-6 m (10-20 ft.)² or 2-8 m (6-27 ft.)³
- Tool Kit

¹ Lowest temperature and cooldown time are for reference only.

² With F-70L

³ With F-70H



CH-210L Cold Head Capacity Map (50 Hz)

With F-70 Compressor and 20 m (66 ft.) Helium Gas Lines

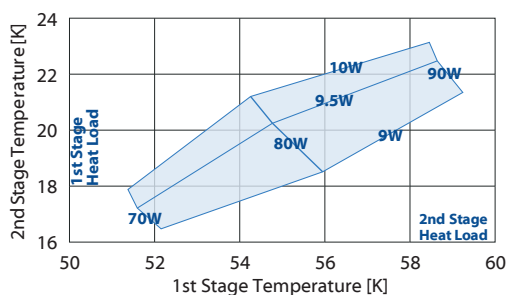

CH-210L Cold Head Capacity Map (60 Hz)

With F-70 Compressor and 20 m (66 ft.) Helium Gas Lines

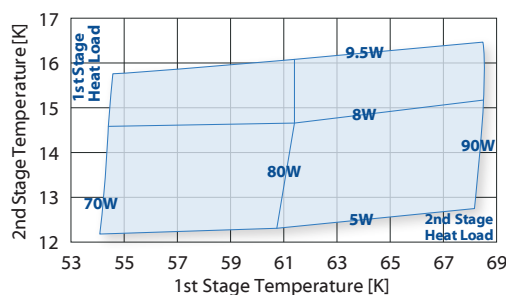

RDK-400B 40K Cryocooler Series

Performance Specifications

Power Supply	50Hz	60 Hz
1 st Stage Capacity	54 W @ 40 K	70 W @ 40 K
Minimum Temperature ²	<25 K	
Cooldown Time to 4.2 K ²	<30 Minutes	
Weight	16.0 kg (35.3 lbs.)	
Dimensions (HxWxD)	357 x 180 x 294 mm (14.1 x 7.1 x 11.6 in.)	
Maintenance	10,000 Hours	
Regulatory Compliance	CE, UL	

Standard Scope of Supply

- RDK-400B Cold Head
- F-50L/H, CSA-71A or FA-70L/H Compressor
- Helium Gas Lines – 20 m (66 ft.)^{2,3}; 6 m (20 ft.) with Buffer Tank^{2,3}; or 10 m (33 ft.) [IDU] + 10 m (33 ft.) [ODU]⁴
- Cold Head Cable – 6-20 m (20-66 ft.)^{2,3} or 10 m (33 ft.)⁴
- Power Cable – 5 m (16.5 ft.)^{2,3} or 5 m (16.5 ft.) [IDU] + 10 m (33 ft.) [ODU]⁴
- Hose Nipples²
- Tool Kit

¹ Lowest temperature and cooldown time are for reference only.

² With F-50

³ With CSA-71A

⁴ With FA-70



RDK-400B Cold Head Capacity Map (50/60 Hz)

With F-50 Compressor and 20 m (66 ft.) Helium Gas Lines

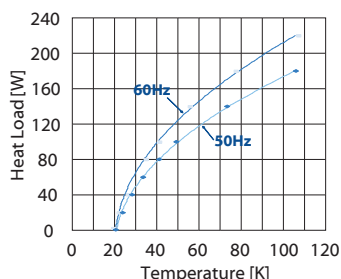

RDK-500B 20K Cryocooler Series

Performance Specifications

Power Supply	50Hz	60 Hz
1st Stage Capacity	40 W @ 20 K 80 W @ 30 K	45 W @ 20 K 94 W @ 30 K
Minimum Temperature¹	<14 K	
Cooldown Time to 20 K¹	<70 Minutes	
Weight	25.0 kg (55.1 lbs.)	
Dimensions (HxWxD)	570 x 180 x 325 mm (22.4 x 7.1 x 12.8 in.)	
Maintenance	8,760 Hours	
Regulatory Compliance	CE, UL/cUL	

Standard Scope of Supply

- RDK-500B Cold Head
- F-70LP/H Compressor
- Helium Gas Lines – 20 m (66 ft.)
- Cold Head Cable – 20 m (66 ft.)
- Power Cable – 5 m (16.5 ft.)
- Tool Kit

¹Lowest temperature and cooldown time are for reference only.



RDK-500B Cold Head Capacity Map (50/60 Hz)
With F-70 Compressor and 20 m (66 ft.) Helium Gas Lines

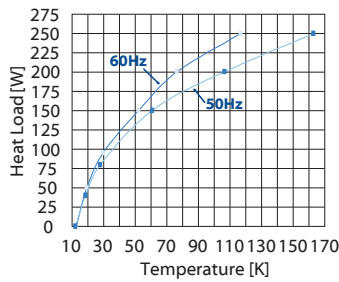

RD-125D 77K Cryocooler Series

Performance Specifications

Power Supply	50Hz	60 Hz
1st Stage Capacity	30 W @ 77 K	
Minimum Temperature¹	<30 K	
Cooldown Time to 77 K¹	<25 Minutes	
Weight	15.0 kg (33.1 lbs.)	
Dimensions (HxWxD)	345 x 140 x 301 mm (13.6 x 5.5 x 11.9 in.)	
Maintenance	10,000 Hours	
Regulatory Compliance	CE, UL, RoHS	

Standard Scope of Supply

- RD-125D Cold Head
- CNA-11 Compressor
- Helium Gas Lines – 7 m (23 ft.)
- Cold Head Cable – 3-6 m (10-20 ft.)
- Power Cable – 5 m (16.5 ft.)
- Tool Kit

¹Lowest temperature and cooldown time are for reference only.



RD-125D Cold Head Capacity Map (50/60 Hz)
With CNA-11 Compressor and 7 m (23 ft.) Helium Gas Lines

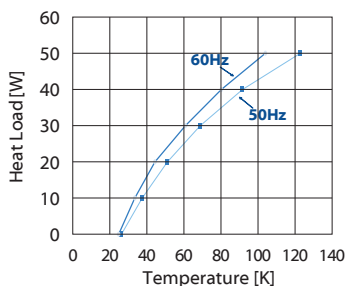

CH-104 77K Cryocooler Series

Performance Specifications

Power Supply	50Hz	60 Hz
1 st Stage Capacity	34 W @ 77 K	42 W @ 77 K
Minimum Temperature ¹	≤40 K	
Cooldown Time to 77 K ¹	<40 Minutes	<30 Minutes
Weight	7.9 kg (17.5 lbs.)	
Dimensions (HxD) ²	362 x ø133 mm (14.3 x ø5.3 in.)	
Maintenance	13,000 Hours	
Regulatory Compliance	CE	

CH-104 Cold Head Capacity Map (50/60 Hz)
With HC-4E1 Compressor and 3 m (10 ft.) Helium Gas Lines

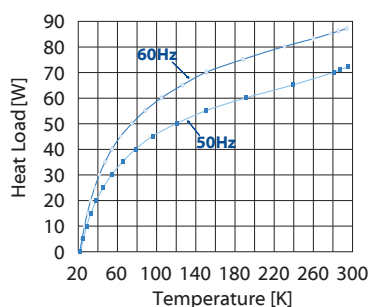

Standard Scope of Supply

- CH-104 Cold Head
- HC-4E, HC-8E, F-70L/H or Zephyr[®] Compressor³
- Helium Gas Lines – 3-25 m (10-82 ft.)
- Cold Head Cable – 3.5-15 m (11-50 ft.)⁴, 3-18 m (10-60 ft.)⁵ or 3-20 m (10-66 ft.)^{6,7}
- Power Cable – 3-6 m (10-20 ft.)⁶ or 2-8 m (6-27 ft.)⁷
- Tool Kit

¹ Lowest temperature and cooldown time are for reference only.

² With standard flat warm flange. (Available in other warm flange interfaces.)

³ Up to two (2) cold heads can be operated with the F-70 Compressor.

⁴ With HC-4E or Zephyr[®]

⁵ With HC-8E

⁶ With F-70L

⁷ With F-70H



CH-110 77K Cryocooler Series

Performance Specifications

Power Supply	50Hz	60 Hz
1 st Stage Capacity	175 W @ 77 K	200 W @ 77 K
Minimum Temperature ¹	≤40 K	
Cooldown Time to 77 K ¹	<35 Minutes	<30 Minutes
Weight	13.7 kg (30.2 lbs.)	
Dimensions (HxD) ²	429 x ø184 mm (16.9 x ø7.2 in.)	
Maintenance	13,000 Hours	
Regulatory Compliance	CE	

CH-110 Cold Head Capacity Map (50/60 Hz)
With F-70 Compressor and 20 m (66 ft.) Helium Gas Lines

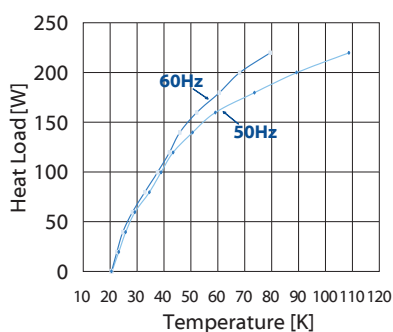

Standard Scope of Supply

- CH-110 Cold Head
- HC-4E, HC-8E, F-70L/H, Zephyr[®] or FA-70L/H Compressor³
- Helium Gas Lines – 3-25 m (10-82 ft.)^{4,5}; 3-20 m (10-66 ft.)^{6,7}; or 10 m (33 ft.) [IDU] + 10 m (33 ft.), 20 m (66 ft.) or 30 m (99 ft.) [ODU]⁸
- Cold Head Cable – 3.5-15 m (11-50 ft.)⁴, 3-18 m (10-60 ft.)⁵, 3-20 m (10-66 ft.)^{6,7} or 33 ft. (10 m)⁸
- Power Cable – 3-6 m (10-20 ft.)⁶; 2-8 m (6-27 ft.)⁷; or 5 m (16.5 ft.) [IDU] + 10 m (33 ft.), 20 m (66 ft.) or 30 m (99 ft.) [ODU]⁸
- Tool Kit

¹ Lowest temperature and cooldown time are for reference only.

² With standard flat warm flange. (Available in other warm flange interfaces.)

³ Reduced capacities when operated with HC-4E, HC-8E or Zephyr Compressors.

⁴ With HC-4E or Zephyr[®]

⁵ With HC-8E

⁶ With F-70L

⁷ With F-70H

⁸ With FA-70

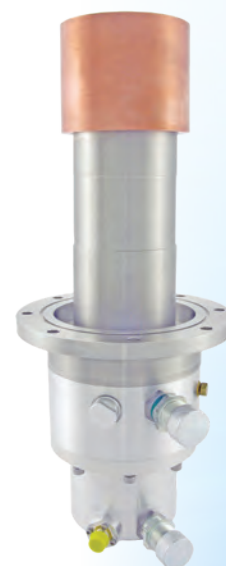

CH-110LT 40K Cryocooler Series

Performance Specifications

Power Supply	50Hz	60 Hz
1 st Stage Capacity	80 W @ 40 K	95 W @ 40 K
Minimum Temperature ¹	<15 K	
Cooldown Time to 77 K ¹	<35 Minutes	<30 Minutes
Weight	13.8 kg (30.5 lbs.)	
Dimensions (HxD) ²	429 x ø184 mm (16.9 x ø7.2 in.)	
Maintenance	13,000 Hours	
Regulatory Compliance	CE	

Standard Scope of Supply

- CH-110LT Cold Head
- F-70L/H or FA-70L/H Compressor
- Helium Gas Lines – 3-20 m (10-66 ft.)^{3,4}; or 10 m (33 ft.) [IDU] + 10 m (33 ft.), 20 m (66 ft.) or 30 m (99 ft.) [ODU]⁵
- Cold Head Cable – 3-20 m (10-66 ft.)^{3,4} or 33 ft. (10 m)⁵
- Power Cable – 3-6 m (10-20 ft.)³; 2-8 m (6-27 ft.)⁴; or 5 m (16.5 ft.) [IDU] + 10 m (33 ft.), 20 m (66 ft.) or 30 m (99 ft.) [ODU]⁵
- Tool Kit

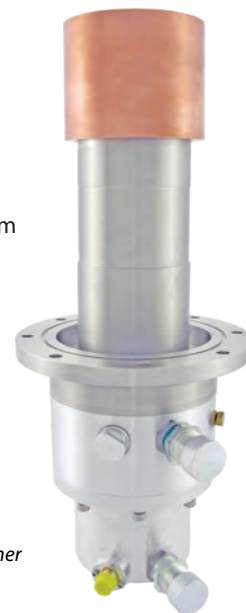

CH-110LT Cold Head Capacity Map (50/60 Hz)

With F-70 Compressor and 6 m (20 ft.) Helium Gas Lines

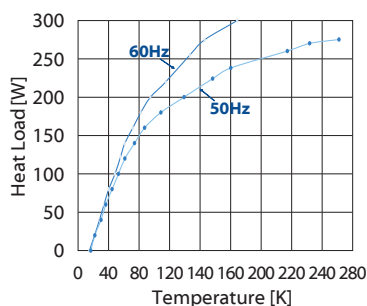

¹Lowest temperature and cooldown time are for reference only.

²With standard flat warm flange. (Available in other warm flange interfaces.)

³With F-70L

⁴With F-70H

⁵With FA-70

SHI Cryogenics Group Locations Europe

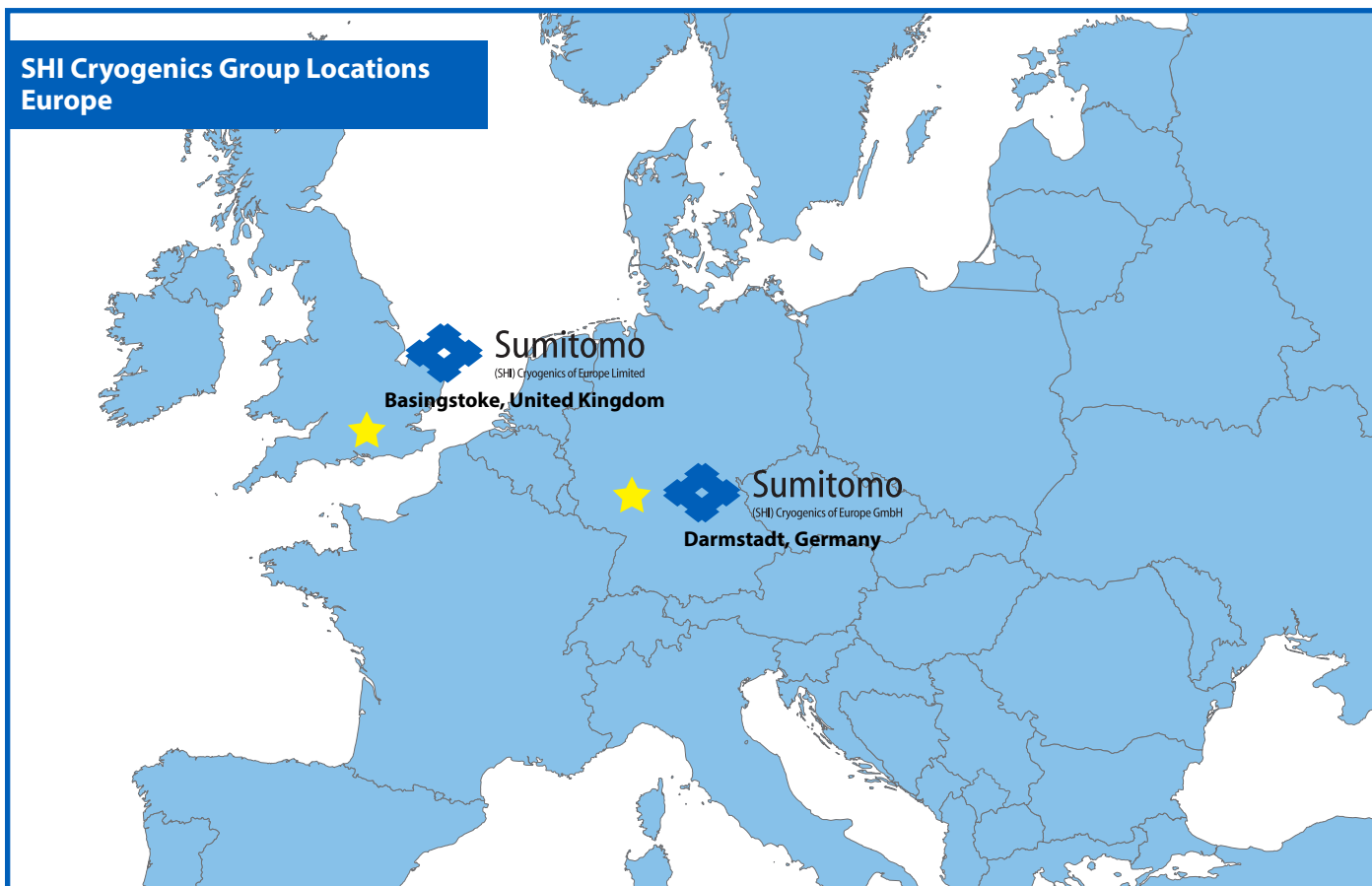



Custom Cryocooler Designs

In addition to standard configurations, SHI offers a variety of options to customize your cryocooler design. Particular customization options vary by model, but may include:

- Nickel plating
- Bakeable option
- Standard and CF flange options, including bolt-on skirt with ports
- Heat station variations
 - Flanged or unflanged
 - Finned recondenser
 - With or without 1st stage heat station
- Custom cylinder modification
- Helium port orientation

Please contact your local SHI Cryogenics Group office to discuss available options for your next project.



Nickel Plating



Finned Recondenser



Conflat Flanges

No 1st Stage Heat Station



Unflanged Heat Stations

Water-Cooled Compressor Options

All SHI Cryocoolers and Pulse Tubes are driven by highly-efficient and reliable compressors. The water-cooled options detailed below boast industry-leading 20,000 or 30,000 hour maintenance intervals, and are available in single or three-phase options, as well as low and high voltage versions.



Compressor Model	HC-4E	CKW-21A	HC-8E	F-40	
				L	H
Electrical Supply¹	1 Phase 200 V, 230/240 V, 50 Hz 200/208/230 V, 60 Hz	3 Phase 200 V, 50/60 Hz	3 Phase 220 V, 50 Hz 220/230 V, 60 Hz	3 Phase 200 V, 50/60 Hz	3 Phase 380, 400, 415 V, 50 Hz 460-480 V, 60 Hz
Power Consumption²	2.6 kW at 50 Hz 3.0 kW at 60 Hz	2.7-3.3 kW at 50 Hz 3.5-4.0 kW at 60 Hz	3.7 kW at 50 Hz 4.3 kW at 60 Hz	3.6-4.8 kW at 50 Hz 4.6-5.6 kW at 60 Hz	
Ambient Temperature³	4-40 °C (39-104 °F)	5-35 °C (41-95 °F)	4-40 °C (39-104 °F)	4-40 °C (39-104 °F)	
Cooling Water (Inlet)	2.7 L/min. (0.7 gal./min.) 4-27 °C (39-80 °F)	3.0-3.5 L/min. (0.8-0.9 gal./min.) 4-28 °C (39-82 °F)	5.7-9.5 L/min. (1.5-2.5 gal./min.) 4-21 °C (39-70 °F)	4-9 L/min. (1.0-2.4 gal./min.) 5-25 °C (41-77 °F)	
Dimensions (HxWxD)	504 x 430 x 485 mm (19.8 x 16.9 x 19.1 in.) 504 x 430 x 605 mm (19.8 x 16.9 x 23.8 in.) with transformer	471 x 401 x 450 mm (18.5 x 15.8 x 17.7 in.)	504 x 430 x 485 mm (19.8 x 16.9 x 19.1 in.)	532 x 442 x 493 mm (20.9 x 17.4 x 19.4 in.)	
Weight	75 kg (165 lbs.) 82 kg (180 lbs.) w/ transformer ⁴	70 kg (155 lbs.)	75 kg (165 lbs.)	96 kg (212 lbs.)	
Maintenance	30,000 Hours	20,000 Hours	30,000 Hours	30,000 Hours	

1. Power may differ depending upon the cold head used.

2. Typical power consumption

3. Cooling capacity may degrade if ambient temperature is above 28 °C (82 °F).

4. RDK-101D(L) drive unit weighs an additional 1.0 kg (2.2 lbs.).

Specifications subject to change without notice.



F-50		F-50S		F-70			F-100	
L	H	L	H	LP	L	H	L	H
3 Phase 200 V, 50/60 Hz	3 Phase 380/400/ 415 V, 50 Hz 460/480 V, 60 Hz	3 Phase 200 V, 50/60 Hz	3 Phase 380/400/ 415 V, 50 Hz 460/480 V, 60 Hz	3 Phase 200 V, 50/60 Hz		3 Phase 380-415 V, 50 Hz 480 V, 60 Hz	3 Phase 200 V, 50 Hz 200, 230 V, 60 Hz	3 Phase 380/400/ 415 V, 50 Hz 460/480 V, 60 Hz
6.5-7.2 kW at 50 Hz 7.5-8.3 kW at 60 Hz		6.5-7.2 kW at 50 Hz 7.5-8.3 kW at 60 Hz		6.6-8.5 kW at 50 Hz 7.5-9.8 kW at 60 Hz	6.6-6.9 kW at 50 Hz 7.5-7.8 kW at 60 Hz	6.6-8.5 kW at 50 Hz 7.5-9.8 kW at 60 Hz	11.8-13.7 kW at 50 Hz 14.5-16.3 kW at 60 Hz	
5-35 °C (41-95 °F)		5-35 °C (41-95 °F)		4-40 °C (39-104 °F)			5-35 °C (41-95 °F)	
7-10 L/min. (1.8-2.6 gal./min.) 4-28 °C (39-82 °F)		7-10 L/min. (1.8-2.6 gal./min.) 4-28 °C (39-82 °F)		6-9 L/min. (1.6-2.4 gal./min.) 5-25 °C (41-77 °F)			8-10 L/min. (2.1-2.6 gal./min.) 4-28 °C (39-82 °F)	
591 x 450 x 485 mm (23.3 x 17.7 x 19.1 in.)		671 x 450 x 485 mm (23.3 x 17.7 x 19.1 in.)		532 x 443 x 493 mm (20.9 x 17.4 x 19.4 in.)			1331 x 511 x 512 mm (52.4 x 20.1 x 20.2 in.)	
120 kg (264 lbs.)		120 kg (265 lbs.)		100 kg (220 lbs.)			250 kg (551 lbs.)	
30,000 Hours		30,000 Hours		30,000 Hours			30,000 Hours	

Air-Cooled Compressor Options

All SHI Cryocoolers and Pulse Tubes are driven by highly-efficient and reliable compressors. The air-cooled options detailed below boast industry-leading 20,000 or 30,000 hour maintenance intervals, and are available in single or three-phase options, as well as low and high voltage versions.



Compressor Model	CNA-11		Zephyr®
	B	C	
Electrical Supply ¹	1 Phase 100 V, 50/60 Hz	1 Phase 100, 120, 220, 230, 240 V, 50/60 Hz	1 Phase 200, 220, 230/240 V, 50 Hz 200, 220 V, 60 Hz
Power Consumption ²	1.2-1.3 kW at 50 Hz 1.3-1.5 kW at 60 Hz		3.0 kW at 50 Hz 3.4 kW at 60 Hz
Ambient Temperature ³	4-38 °C (39-100 °F)		4-32 °C (39-90 °F)
Cooling Air	2.7 m ³ /min. (95 cfm), 50 Hz 3.3 m ³ /min. (117 cfm), 60 Hz		14 m ³ /min. (500 cfm), 50/60 Hz
Dimensions (HxWxD)	400 x 383 x 450 mm (15.7 x 15.1 x 17.7 in.)	610 x 383 x 450 mm (24.0 x 15.1 x 17.7 in.)	715 x 453 x 488 mm (28.2 x 17.8 x 19.2 in.) 715 x 453 x 605 mm (28.2 x 17.8 x 23.8 in.) with transformer
Weight	42 kg (93 lbs.) ⁴	75 kg (165 lbs.) ⁴	102 kg (225 lbs.) 111 kg (245 lbs.) with transformer ⁴
Maintenance	30,000 Hours		30,000 Hours

1. Power may differ depending upon the cold head used.
2. Typical power consumption
3. Cooling capacity may degrade if ambient temperature is above 28 °C (82 °F).
4. RDK-101D(L) drive unit weighs an additional 1.0 kg (2.2 lbs.).

Specifications subject to change without notice.



FA-40		CSA-71A	FA-70	
L	H		L	H
3 Phase 200 V, 50/60 Hz	3 Phase 380/400/415 V, 50 Hz 460/480 V, 60 Hz	3 Phase 200 V, 50/60 Hz	3 Phase 200 V, 50/60 Hz	3 Phase 380/400/415 V, 50 Hz 460/480 V, 60 Hz
3.6-5.4 kW at 50 Hz 4.6-6.4 kW at 60 Hz		6.5-7.2 kW at 50 Hz 7.5-8.3 kW at 60 Hz	6.9-8.0 kW at 50 Hz 7.9-9.0 kW at 60 Hz	
4-38 °C (39-100 °F)		5-35 °C (41-95 °F)	4-40 °C (39-104 °F) - Indoor 30-45 °C (82-113 °F) - Outdoor	
14.7 m ³ /min. (520 cfm), 50 Hz 17.6 m ³ /min. (620 cfm) 60 Hz		28 m ³ /min. (989 cfm), 50/60 Hz	23.5/47.3 m ³ /min. (830/1670 cfm), 50 Hz 26.6/53.8 m ³ /min. (940/1900 cfm), 60 Hz Low/high fan speed	
889 x 442 x 493 mm (35.0 x 17.4 x 19.4 in.)		885 x 550 x 550 mm (34.8 x 21.7 x 21.7 in.)	652 x 267 x 546 mm (25.7 x 10.5 x 21.5 in.) - Indoor 1016 x 391 x 948 mm (40 x 15.4 x 37.3 in.) - Outdoor	
110 kg (242 lbs.)		140 kg (309 lbs.)	46 kg (101 lbs.) - Indoor 142 kg (312 lbs.) - Outdoor	
30,000 Hours		20,000 Hours	30,000 Hours	



Service

Global Service & Support Programs

At SHI Cryogenics Group, we realize that our customers are diverse and the markets they serve are demanding and unique. In response, our global service and support network offers responsive and value-added support for our complete range of products. Our factory-trained technicians are located in strategic service centers around the globe and offer 24/7 on-call support.

Our service and support offerings differ by product type. However, our complete range of services is both flexible and cost effective, including:

- Product return to local service depot for service, repair or complete refurbishment
- Assistance in diagnosing equipment issues via phone or e-mail
- Product exchange programs (contact your local service center for available products)



- Customer training programs
- Customized service contracts
- Full factory warranty

SHI factory-trained service technicians are also available for on-site training, scheduled maintenance or emergency visits.

RDK Series Cryocooler Service Options

Product repairs and refurbishments performed at SHI Service Centers include:

- Flow check of all internal parts to ensure optimum refrigeration capacity
- Replacement of required wear items—seals, valve disc, valve stem, capillaries and displacers, when necessary
- Performance testing to factory specification
- Leak check, both pressurized and for vacuum integrity, where applicable

We also understand that there are cases where complete removal and return of the cryocooler is overly difficult. In response, SHI also offers “hot swap” service performed by SHI technicians.

RP Series Pulse Tube Cryocooler Service Options

Due to the unique operating environment of these cryocoolers, on-site service and maintenance by non-SHI technicians is not recommended at this time. SHI technicians can perform a limited amount of service on-site, including the cleaning and replacement of wear items, gas cleanup and additional tuning. However, the most reliable approach to service and maintenance on these cryocoolers is to return them to one of SHI’s service centers. Product repairs and refurbishments performed at SHI Service Centers include:

- Replacement of required wear items—valve stem and filter unit, when necessary
- Cryogenic gas cleansing of all system components
- Performance testing to factory specification
- Leak check, both pressurized and for vacuum integrity, where applicable

CH and DE Series Cryocoolers Service Options

Like the RDK Series Cryocoolers, CH and DE Series Cryocoolers can be serviced via hot swap, on-site by the customer or by an SHI factory-trained technician, without removing the cryocooler for return or replacement. In the case of the CH and DE Series, this unique service option is the result of high-quality, ultra-reliable Displex® Cryocooler technology. Displex Cryocoolers have a long and successful operating history, and feature a pneumatic drive that optimizes performance and reliability and permits quick and easy removal of the displacer assembly for maintenance.



In addition, these cryocoolers can be returned to one of SHI's service centers. Product repairs and refurbishments performed at SHI Service Centers include:

- Flow check of all internal parts to ensure optimum refrigeration capacity
- Replacement of required wear items—seals, valve disc, valve stem, capillaries and displacers, when necessary
- Performance testing to factory specification
- Leak check, both pressurized and for vacuum integrity, where applicable

Compressor Service Options

Many minor maintenance tasks, such as adsorber replacement and leak checking, can be performed on-site by the customer or by an SHI factory-trained technician. If returned to one of SHI's service centers, product repairs and refurbishments include:

- Full diagnostic review—mechanical, electrical, flow displacement and moisture content
- Motor capsule replacement, if needed
- Heat exchanger replacement, if needed
- Adsorber replacement
- Cryogenic gas cleansing of all system components
- Leak testing
- Performance testing to factory specification

Whichever service program is right for you, you can be assured that all SHI work will be performed in our world-class service centers or on site by a qualified service technician. Please contact your local SHI Cryogenics Group office for more information, or for a service and support package that meets the needs of your organization.



What Is Hot Swap Service?

Hot swap service allows for "in situ" maintenance, without the need to remove the complete cryocooler for return or replacement. Hot swap service involves complete exchange of the cryocooler assembly, with the exception of the cylinder, which remains installed in the customer's system. Hot swap implies that the customer's system is accessible, has any ancillary instrumentation removed in advance, and is warm, allowing for reliable removal and exchange.

Performing hot swap service lowers the total cost of ownership by:

- Eliminating the cost of shipping a complete cryocooler to a service center
- Eliminating labor costs associated with complete disassembly of the cryocooler from your system
- Minimizing the "down time" of your system for service or repair
- Minimizing the required capital investment in spare parts

Accessories and Parts

Helium Gas Lines

SHI Cryocooler systems come equipped with flexible helium gas lines. Standard lengths range from 3 meters (10 feet) to 20 meters (66 feet), depending on the system. Gas lines terminate in coupling halves for quick connect and disconnect to and from the cold head and compressor and are also available with one end at 90°. All flexible gas lines are pre-charged with clean helium gas.

SHI superflex lines offer superior flexibility and smaller bend radius without thinning the wall of the hose and offer a higher flexing cycle life than standard lines. Superflex lines also dampen vibration and noise of the helium gas traveling through the lines.



Cold Head Cables

SHI offers a complete line of cables that transmit the appropriate power from the compressor to the cold head on our standard cryocooler systems. Cable lengths vary by type of system.

Tool Kits

Available tool kits range from standard installation wrench kits to more comprehensive kits that include such items as gas charging valves and additional tools for installation, maintenance or service on SHI cryocooler systems. Standard kits that accompany new equipment vary by type of system. Contact your local SHI office for details.

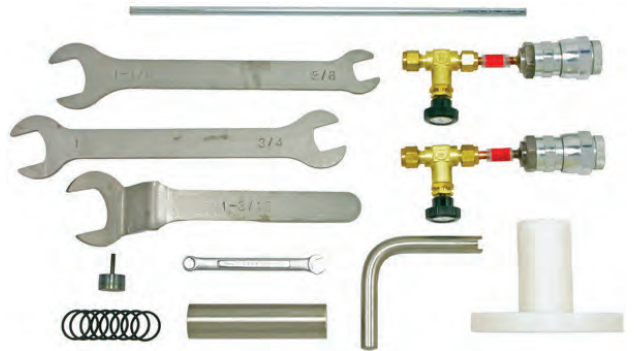

Replacement Parts Kits and Exchange Units

SHI offers a complete line of replacement parts kits that include all of the required parts and assemblies to completely recondition CH Series cryocoolers and related compressors. Complete exchange units may also be available, particularly for our 4KGM and Pulse Tube Cryocoolers, which require any additional work to be done by SHI factory-trained service technicians. Contact your local SHI office for details.

Other Products

In addition to the cryocoolers featured in this catalogue, SHI Cryogenics Group designs and manufactures Cryopumps, Shield Coolers and other low temperature cooling technology.

SICERA® Ultra Cryopumps

The SICERA Ultra Cryopump uses SHI proprietary inverter technology to reduce customer energy costs, allowing up to eleven 8-inch pumps to operate on a single compressor. The resulting savings and increased production efficiency make SICERA Ultra ideal for high-volume production of semiconductor wafers, flat panel displays and other semiconductor-related products.

The complete SICERA Ultra cryopump system includes a compressor and remote controller, which have been thoroughly tested to withstand the most demanding vacuum applications. Through continuous control of both the cryocooler and compressor, SHI Cryogenics Group is able to offer a reliable cryopump system with significant energy savings, as well as excellent temperature and vacuum stability.



SICERA® Ultra Cryopumps

SIGNET® Cryopumps

SIGNET Cryopumps use double inverter technology to offer increased energy savings for sputtering and evaporation systems. Available in 12 through 22-inch sizes, SIGNET systems are specially designed for multi-pump operation. Between two and four pumps can operate on a single compressor, reducing the system's overall footprint, as well as its total operating cost. Like SICERA, the complete SIGNET cryopump system includes a robust compressor and remote controller. Its intelligent design combines a high-efficiency design with power and water savings to create a complete package for the flat panel display and similar industries.



SIGNET® Cryopumps

Marathon® CP Cryopumps

Marathon CP Series Cryopumps are specifically designed to meet the needs of high vacuum processes. Applications for these versatile systems range from custom laboratory equipment to industrial-scale tools. Manufacturers of semiconductor devices, flat panel displays, test equipment, solar manufacturing and a wide variety of coating and thermal vacuum systems require efficient, reliable and robust systems that offer a low cost of ownership. The Marathon CP Series Cryopumps deliver on all fronts.

A range of standard and low profile enclosures, ANSI, ISO and CF flanges, as well as manual and fully automatic features, ensure that users have modularity and flexibility to choose from when designing their systems. All Marathon CP Series Cryopumps are driven by highly-efficient and reliable helium compressors. These compressors boast an industry leading 30,000 hour maintenance interval. Compressors are available in single-phase and three-phase, low and high voltage versions.

For those users requiring the latest in efficient, fully-automated operation, SHI Cryogenics Group offers our Marathon Cryopump Controller (MCC). The MCC enables fully automatic operation and monitoring of the cryopump system using commands from a host computer and industry standard cryopump protocol. If you do not utilize a host computer, optional software is available to interface the MCC to a standard Windows-based computer. The result of utilizing the Marathon CP Cryopump with MCC is greatly reduced downtime between production cycles, improved process times and better overall efficiency of the user's process.



Marathon® CP Cryopumps

For Information in:

Asia

Sumitomo Heavy Industries, Ltd.
ThinkPark Tower
1-1 Osaki 2-chome, Shinagawa-ku
Tokyo 141-6025
Japan
Phone: +81-3-6737-2550
Fax: +81-3-6866-5114
E-mail: shi.cryo@shi-g.com

Service Office
2-1-1, Yato-cho, Nishitokyo-city
Tokyo 188-8585
Japan
Phone: +81-42-468-4252
Fax: +81-42-468-4254

Sumitomo (SHI) Cryogenics Shanghai, Ltd.
Building 15, Lane 333
Zhujian Road, Minhang District
Shanghai 201107
P.R. China
Phone: +86-21-5486-6318
Fax: +86;21;5486-0067
E-mail: GR.SCSL.Sales@shi-g.com
GR.SCSL.Service@shi-g.com

Sumitomo (SHI) Cryogenics Korea, Co., Ltd.
280-3, Saneop-ro
155beon-gil, Gweonseon-Gu
Suwon-Si, Gyeonggi-Do
Suwon-City, 441-813
South Korea
Phone: +82-31-278-3050
Fax: + 82-31-278-3053
E-mail: sales@shicryogenics.co.kr
service@shicryognics.co.kr

Sumitomo (SHI) Cryogenics Taiwan Co., Ltd.
4th Floor, No.3
Lane 216, Gongyuan Road
Hsinchu City 30069
Taiwan R.O.C
Phone: +886-3-561-2557
Fax: +886-3-562-3400

United States

Sumitomo (SHI) Cryogenics of America, Inc.
1833 Vultee Street
Allentown, PA 18103
Phone: +1-610-791-6700
Fax: +1-610-791-0440
E-mail: sales@shicryogenics.com
service@shicryogenics.com

Sumitomo (SHI) Cryogenics of America, Inc.
1500-C Higgins Road
Elk Grove Village, IL 60007
Phone: +1-847-290-5801
Fax: +1-847-290-1984

Europe

Sumitomo (SHI) Cryogenics of Europe, Ltd.
3 Hamilton Close, Houndmills Industrial Estate
Basingstoke, Hampshire RG21 6YT
United Kingdom
Phone: +44-1256-853333
Fax: +44-1256-471507
E-mail: uksales@shicryogenics.co.uk
ukservice@shicryogenics.co.uk

Sumitomo (SHI) Cryogenics of Europe, GmbH
Daimlerweg 5a
Darmstadt D-64293
Germany
Phone: +49-6151-860610
Fax: +49-6151-800252
E-mail: sceg.contact@shi-g.com

Visit us anytime, worldwide. www.shicryogenics.com