

PIT JACK GD-2

AIR HYDRAULIC TWIN RAM PIT JACK

Item number: GD-2

- ✓ 2 individually controlled rams offer safe and balanced lifting
- ✓ Rapid and precise air hydraulic unit with high speed ram travel
- ✓ Simple modern design with control panel at ergonomical working height
- ✓ Transversely sliding rams
- ✓ Can be made to fit all pits due to its adjustable frame

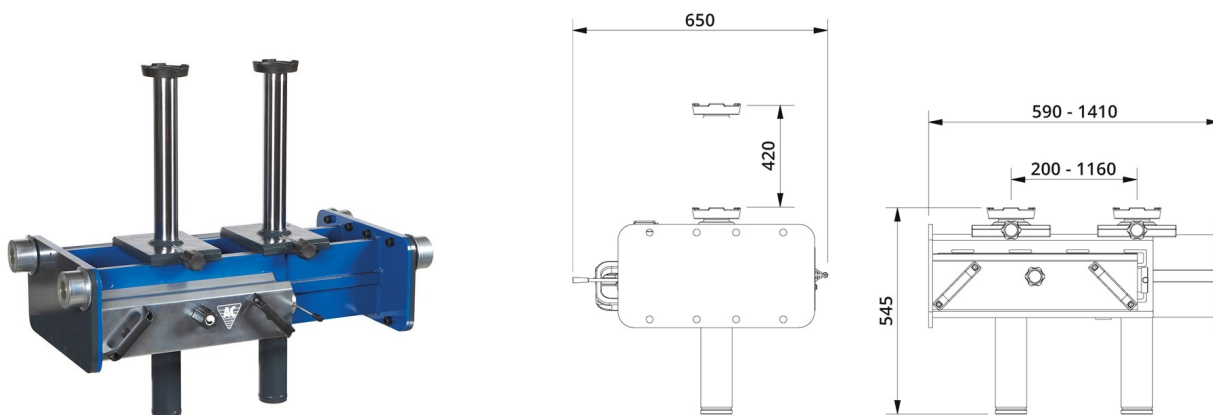

Capacity:	10 / 15 / 20 t
Stroke:	420 mm
Min height:	545 mm
Max height:	945 mm
Depth:	650 mm
Cylinder diameter:	60 mm
Air supply:	8 - 10 bar
Weight:	220 kg