

T 5573 EN

TROVIS 5573 Heating and District Heating Controller



Application

Control of up to two control circuits



Fig. 1: TROVIS 5573 Heating and District Heating Controller

- 1 TROVIS 5573-0 with icon readings on the display
- 2 TROVIS 5573-1 with plain-text readings on the graphics display

- Control of a primary heat exchanger or boiler with one mixing heating circuit and one non-mixing heating circuit (both outdoor-temperature-compensated) and control of DHW heating in the secondary circuit
- Outdoor-temperature-compensated buffer tank control with solid fuel boiler and solar circuit control
- Control of one outdoor-temperature-compensated heating circuit and a DHW heating with two valves in the primary circuit
- Control of two outdoor-temperature-compensated heating circuits with two valves in the primary circuit

Special features

- Rotary switch for direct access to the operating modes and key parameters of the control circuits
- Intuitive data retrieval and input by pressing and turning the pushbutton
- 365-day time switch with up to four time schedules and automatic summer time/winter time changeover; up to three times-of-use per day (input in steps of 15 minutes)
- Room panels connected to individual heating circuits to override operating mode and rated room temperature
- Demand-driven control by set point demand by subsequent controllers over a 0 to 10 V signal: The primary circuit controls the maximum flow temperature demanded plus adjustable boost.
- Heating characteristics optionally based on the gradient or based on four points; variable return temperature limitation
- Adaptation: Automatic adaptation of the heating characteristic (room temperature sensor required)
- Optimization: Calculation of the best possible activation and deactivation times for the heating (room temperature sensor required)
- Drying of jointless floors function with adjustable parameter settings
- Updatable flash memory in controller (operating system)
- Configuration and parameterization using a memory module
- Data logging function
 - Operating data can be saved to a data logging module

- Data can be displayed in the data log viewer on a computer
- TROVIS 5573-1: Analysis on the graphics display of the data saved in the operating data memory

- Heating control only
- Heating control together with DHW heating
- DHW heating only

Outdoor-temperature-compensated flow rate or capacity limitation can also be implemented.

Versions

- **TROVIS 5573-000x**: Heating and district heating controller with icon readings on the display
- **TROVIS 5573-100x**: Heating and district heating controller with plain-text readings on the graphics display
- **TROVIS 5573-110x**: Heating and district heating controller with graphics display and M-Bus interface for three M-Bus units

Installation

- Panel mounting: Two adjustable fixing clamps attached to the controller are used to mount it.
- Wall mounting: The base of the housing is screwed to the wall.
- Rail mounting: The base of the housing is pushed onto a rail.

Optional interfaces for communication:

RS-232 to computer communication module

RS-485 communication module

Design and principle of operation

The heating controller is adapted to the specific system by setting the appropriate system code number. Additional sensors and/or functions which are not part of the system's basic configuration can be selected in the function blocks. The switch positions \diamond and entry of the key number allow access to the corresponding levels. For trained personnel, the configuration levels used to set function blocks are indicated by 'CO' and the parameter levels are indicated by 'PA'. Data is retrieved and entered at the heating controller using a rotary pushbutton.

TROVIS 5573

Data input is facilitated by icons displayed on the LCD.

TROVIS 5573-1

Data input is facilitated by icons and plain text displayed on the LCD.

The rotary switch is used to set the operating mode and the key parameters required for individual circuits.

M-Bus interface

(TROVIS 5573-110x only)

A maximum of three meters conforming to EN 13757 can be connected for data transfer. In addition, heat meters are available for flow rate and/or capacity limitation for each control circuit. Various limits can be adjusted for the following operating modes in control circuit RK1:

Operating controls

The operating controls are located in the front panel of the heating controller.

The rotary pushbutton is used to select readings, parameters and function blocks.

The rotary switch is used to set the operating mode and the key parameters for each control circuit.

Rotary pushbutton

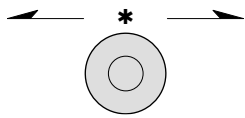

- Turn
Select readings, parameters and function blocks.
- * Press
Confirm adjusted selection or settings.

Rotary switch

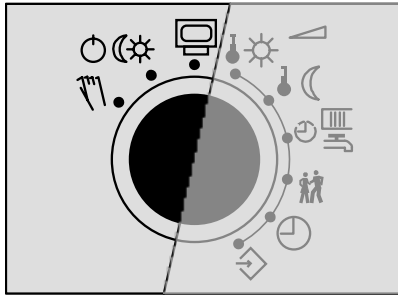

- Operating level
- ☀ Operating modes
- ☞ Manual level

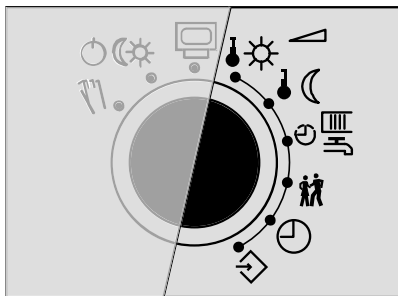

- ↓☀ Day set point (rated room temperature)
- ↓☾ Night set point (reduced room temperature)
- ☁☀ Times-of-use for heating/DHW
- ☀☀ Special time-of-use
- ⌚ Time/date
- ⚙ Settings (parameter and configuration level)

Electrical connection

The controller consists of the housing containing the electronics and a separate terminal board for electrical connection. Two wires with a cross-section of max. 1.5 mm² can be connected to each terminal. The sensor connection lines must be installed separately from the lines carrying the power supply.

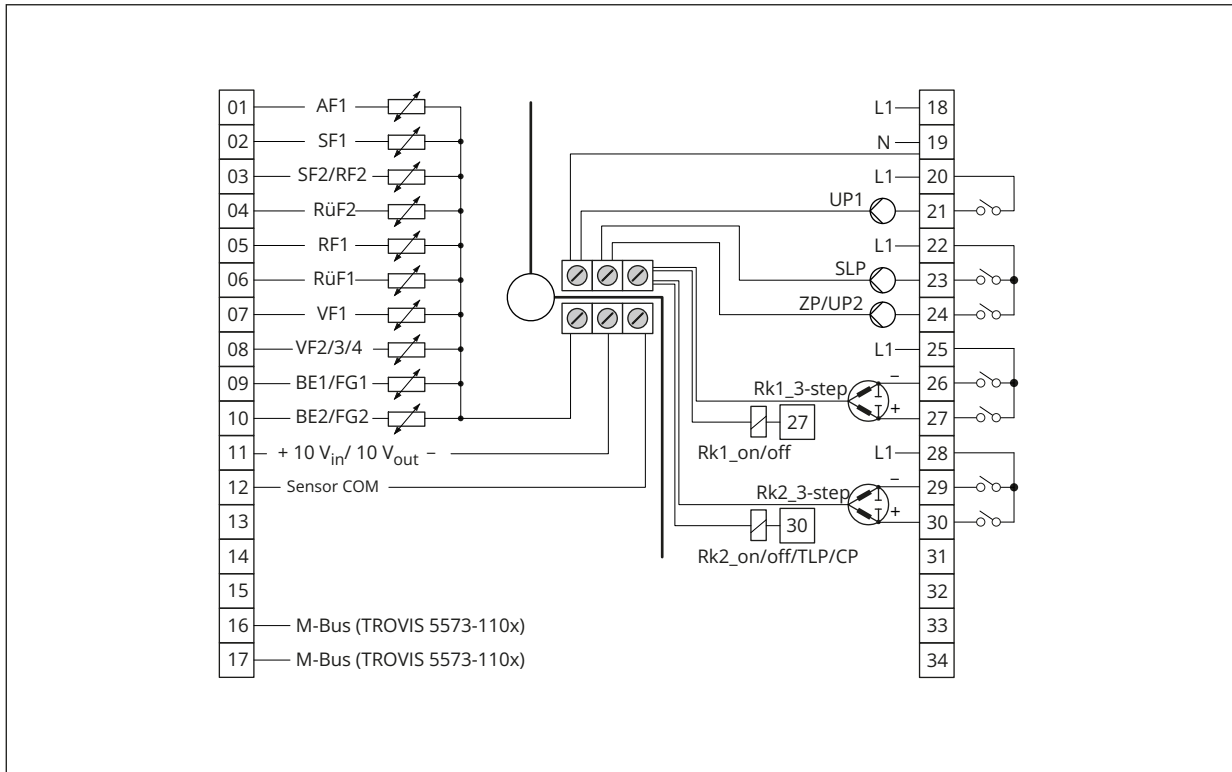

Fig. 2: Wiring of TROVIS 5573 Controller with standard base

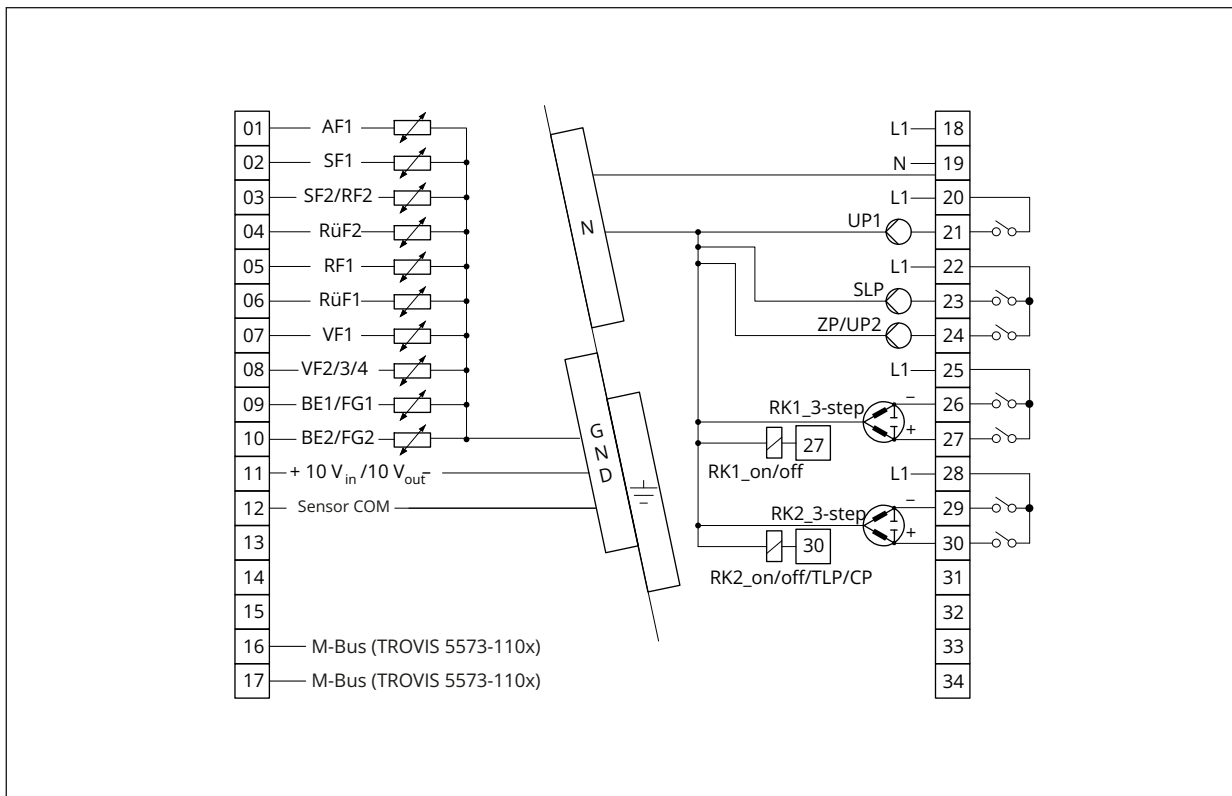

Fig. 3: Wiring of TROVIS 5573 Controller with high base

Abbreviations

AF	Outdoor sensor
BE	Binary input
CP	Solar circuit pump
FG	Potentiometer
RF	Room sensor
RK	Control circuit
RüF	Return sensor
SF	Storage tank sensor
SLP	Storage tank charging pump
TLP	Heat exchanger charging pump
UP	Circulation pump (heating)
VF	Flow sensor
ZP	Circulation pump (DHW)

Room panel

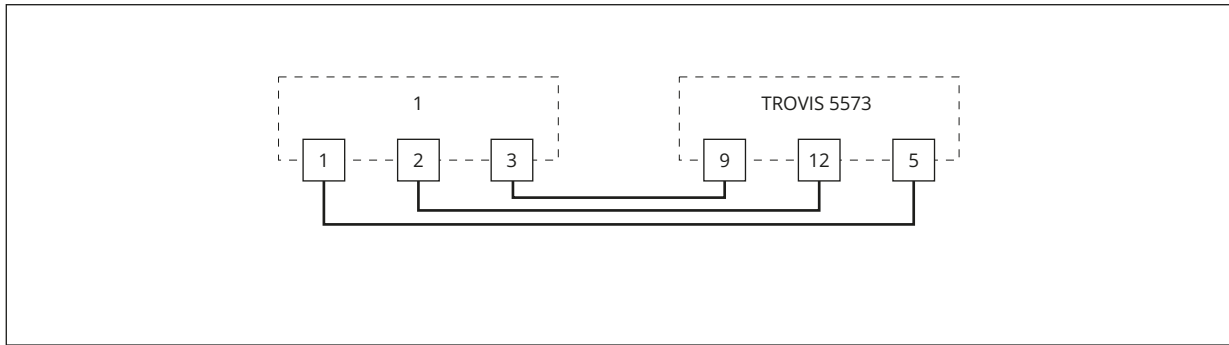

Fig. 4: Wiring of a room panel for RK1

1 Type 5257-5(x) Room Panel; Type 5244 no longer available.

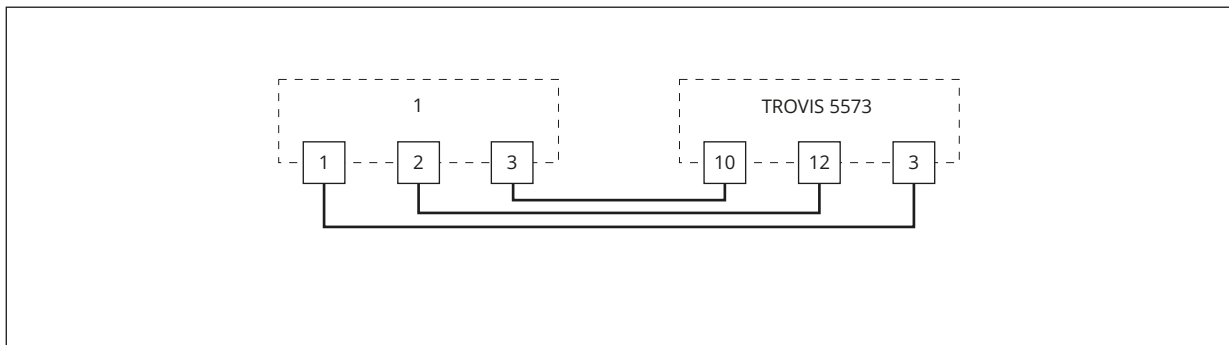

Fig. 5: Wiring of a room panel for RK2

1 Type 5257-5(x) Room Panel; Type 5244 no longer available.

Water flow sensor

(TROVIS 5573-1 only)

WSS		Extension cable	TROVIS 5573-1
GND	BK	BN	12
Signal	GN	GN	10
5 V	WH	WH	11

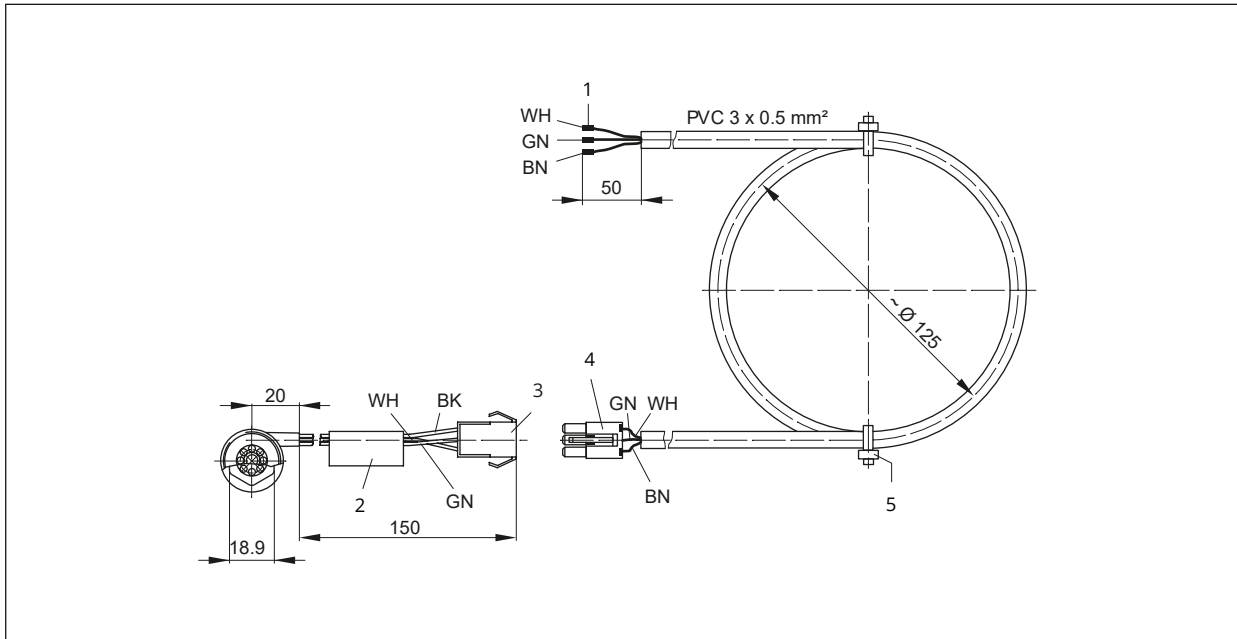

Fig. 6: Extension cable for water flow sensor

- WH White
- GN Green
- BN Brown
- BK Black
- 1 Wire end ferrule
- 2 Nameplate
- 3 Bushing
- 4 Connector
- 5 Cable tie

Table 1: Permissible conductor cross-section for terminals

Cable	Conductor cross-section
Single-wire	0.33 to 2 mm ²
Multi-wire	0.33 to 2 mm ²

Length of insulation to be stripped off the conductor ends: 6 mm

Technical data

Table 2: *Technical data*

Inputs	8x inputs for Pt1000, PTC or Ni1000 temperature sensors and 2x binary inputs Terminal 11 as 0 to 10 V input (e.g. for external demand or outdoor temperature signal)
Outputs ¹⁾	2x three-step signal: rating max. 250 V AC, 2 A, alternatively 2x on/off signal: rating max. 250 V AC, 2 A 3x pump output: rating max. 250 V AC, 2 A; All outputs are relay outputs with varistor suppression Terminal 11 as 0 to 10 V output (e.g. for continuous closed loop control, outdoor temperature, signal for external demand or pump speed control) Load >5 kΩ
Interfaces (TROVIS 5573-110x only)	M-Bus interface (mini master) for up to three M-Bus units, protocol according to EN 13757 (formerly EN 1434-3)
Optional interfaces	1x Modbus RS-485 interface for two-wire bus using RS-485 communication module (Modbus RTU protocol, data format 8N1, RJ-45 port at the side)
Supply voltage	85 to 250 V
Power line frequency	48 to 62 Hz
Power consumption TROVIS 5573	Max. 4.7 VA, typical: 2.3 VA
TROVIS 5573-1	Max. 6 VA, typical: 2.5 VA
Permissible ambient temperature range	
Operation	0 to 55 °C
Transportation and storage	-10 to +60 °C
Degree of protection	IP40 according to EN 60529
Class of protection	II according to EN 61140
Degree of contamination	2 according to EN 61010-1
Overvoltage category	II according to EN 60664-1
Noise immunity	According to EN 61000-6-1
Noise emission	According to EN 61000-6-3
Conformity	CE
Weight	Approx. 0.5 kg

¹⁾ For systems with one control circuit, a maximum of four pumps are available

Dimensions

Panel cut-out: 138 x 92

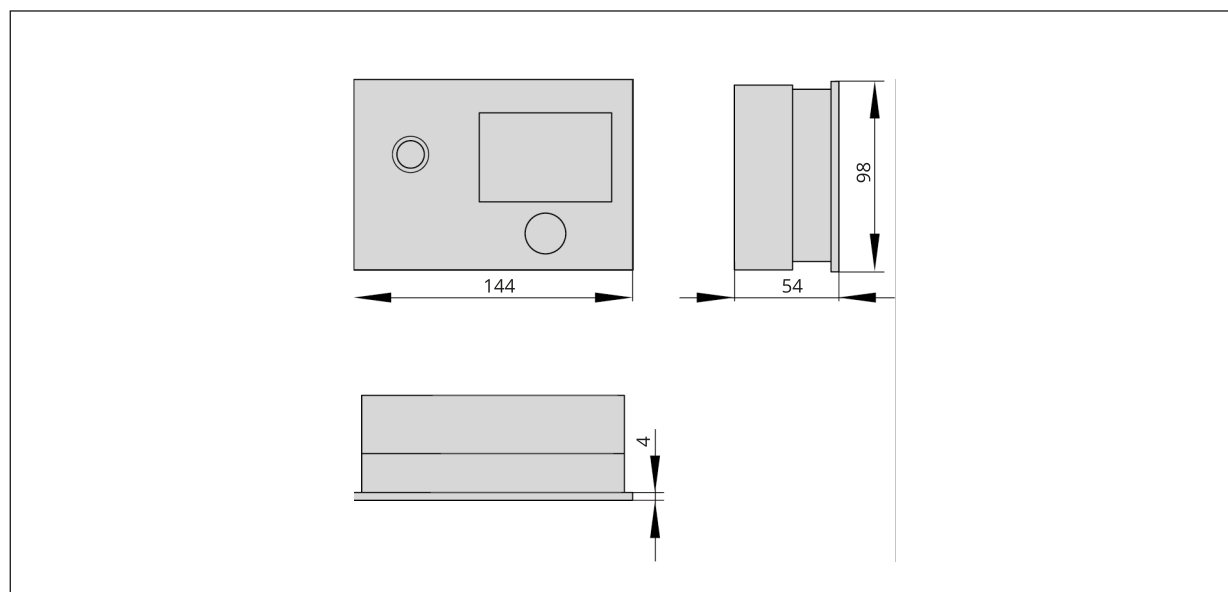

Fig. 7: *Dimensions in mm · Heating and district heating controller with standard base*

Panel cut-out: 138 x 92

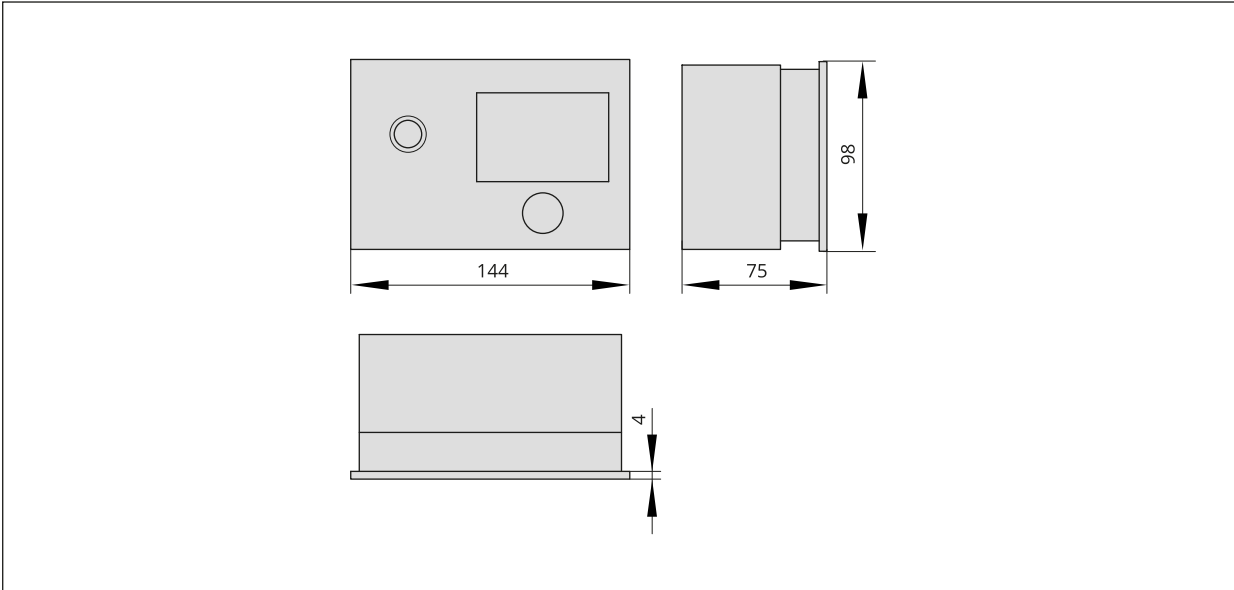

Fig. 8: Dimensions in mm · Heating and district heating controller with high housing base

Accessories

Table 3: *Accessories*

Surge arrester SA 5000	Order no. 1400-9868
Memory module	Order no. 1400-9379
Mini module	Order no. 1400-7436
Data logging module	Order no. 1400-9378
USB Converter 3	Order no. 1400-9377
4-port bus hub	Order no. 1400-7140
RS-485 communication module	Order no. 8812-2002
Modbus GPRS gateway	Order no. 1402-0701
▶ SAM HOME Gateway	Type 5660
▶ SAM MOBILE+ Gateway	Type 5656
TROVIS-VIEW software (free of charge)	▶ www.samsongroup.com > DOWNLOADS > Software & Drivers > TROVIS-VIEW
SAM DISTRICT ENERGY	▶ www.samsongroup.com > PRODUCTS > Digital solutions > SAM DISTRICT ENERGY ▶ EB 6901
Water flow sensor with extension cable (only for TROVIS 5573-1)	Order no. 1400-9246
Sensors and room panels	▶ www.samsongroup.com > PRODUCTS > Sensors and Thermostats ▶ T 5200 (Information Sheet: Temperature Sensors and Thermostats)

Ordering text

TROVIS 5573 Heating and District Heating Controller

- With icon readings on the display/with plain-text readings/with graphics display and M-Bus interface
- With standard base/with high housing base

Associated mounting and operating instructions

- TROVIS 5573 ▶ EB 5573
- TROVIS 5573-1 ▶ EB 5573-1
- TROVIS-VIEW ▶ EB 6661

