

ITEM NO.	PART NUMBER	DESCRIPTION	ДЛИНА	QT.Y.
1	Carcas 850x650x850			1
1.1		Teava profilata 25 X 25 X 1,2	600	2
1.2		Teava profilata 25 X 25 X 1,2	800	2
1.3		Teava profilata 25 X 25 X 1,2	650	2
1.4		Teava profilata 25 X 25 X 1,2	850	2
1.5		Teava profilata 25 X 25 X 1,2	669	4
1.6		Teava profilata 20 X 10 X 1,2	600	8
2	Polita 500x750 N2	S1		1
3	Polita 500x750 N2	S1		1
4	Miner			1
4.1		Teava Φ 22x15	40	2
4.2		Cot Φ 22x15	90°	2
4.3		Teava Φ 22x15	31.42	2
4.4		Cot Φ 22x15	45°	1
5	Roata 125			2
6	Roata 125 frina			2

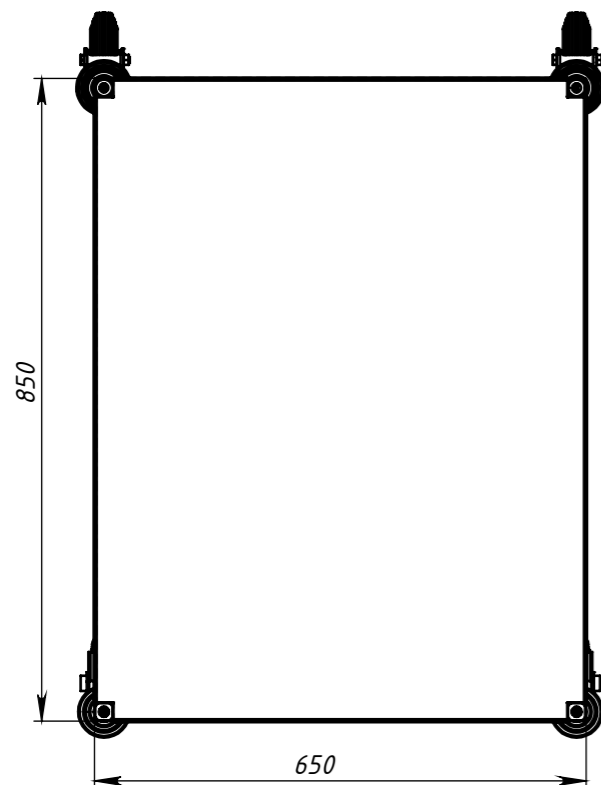

E (1 : 2)

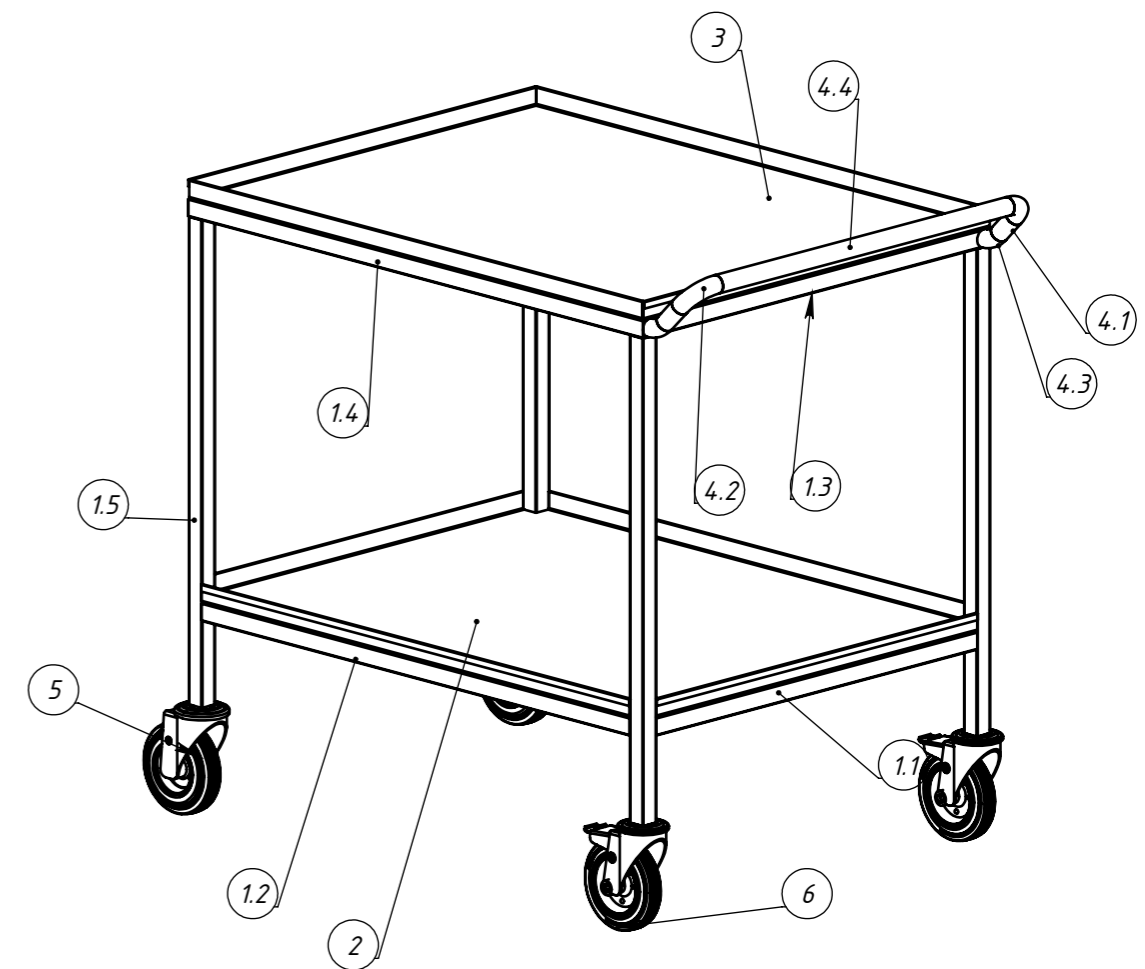
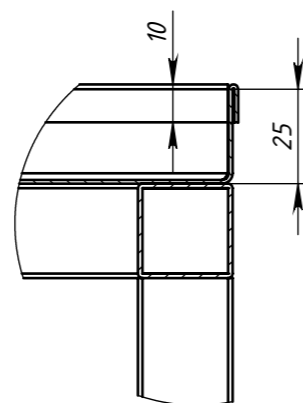

No	
Client	-
Inginer	Pleşivţev Artiom
Termen ex.	...2024

Carucior 850x650x850 cu 2 nivele

METAL EXPERT
TECHNOLOGY