

| Characteristics | | | |
|-----------------------|-------|------|------------------|
| Manufacturer | | | FMAN |
| Model | | | CPCD50 |
| Rated capacity | Q | Kg | 5000 |
| Rated center distance | C | Mm | 500 |
| Power type | | | Diesel |
| Tyre type | | | Pneumatic |
| Front overhang | L2 | Mm | 565 |
| Free lifting height | H1 | Mm | 140 |
| Max. lifting height | H3 | Mm | 5000 |
| Overall size | L*W*T | Mm | 3100*1480*2740 |
| Travelling speed | | Km/h | 18/19 |
| Lifting speed | | Mm/s | 400/450 |
| Gradeability | | % | 20/20 |
| Total weight | | Kg | 6400 |
| Engine | | | XICHAI 4110 61KW |
| Emission | | | Euro 2 |

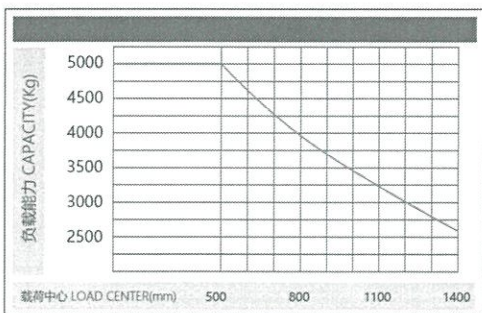
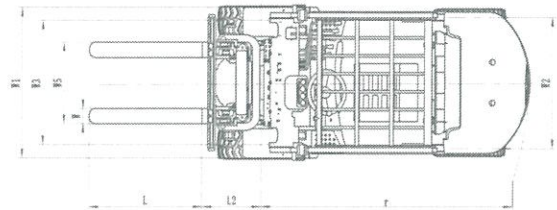
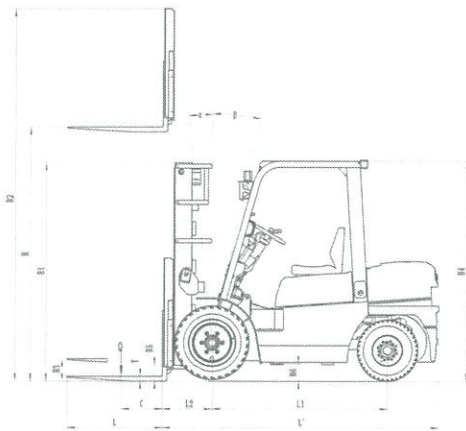

注：

竖轴表示承载量，横轴表示载荷中心。载荷中心是从货叉正面计算起，标准载荷的基点是指负荷边长为 1000 毫米的立方体中心位置。当门架前倾、使用非标准货叉或装载超过正常宽度的负荷时，将会使承载量减少。通过负荷曲线图，能及时地了解标准门架在各种载荷中心时的承载能力。

Note:

The vertical axis stands for the load capacity and the horizontal axis stands for the load center. The load center is calculated from the face of the fork. The base point of the standard load is the center of the cube with a load side length of 1000 mm. When the mast leans forward, or non-standard forks are used, or loads exceeds normal width, the load capacity will be reduced. Through the load chart, the bearing capacity of the standard mast at various load centers can be timely understood.

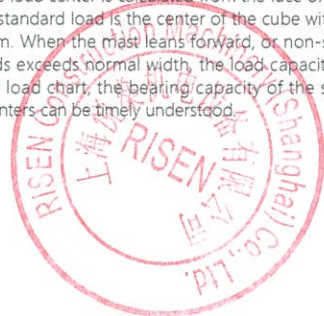

Risen

CERTIFICATE OF EXCLUSIVE DISTRIBUTION

Issuer:

Risen Construction Machinery (Shanghai) Co., Ltd.
Address: Guo'an Road, Yangpu District, 200433, Shanghai, China

Recipient:

Contracting Authority
Agrotrac Prim SRL, Municipality of Chişinău

We hereby certify:

That **AGROTRAC PRIM S.R.L.**, located at MD-2002, Republic of Moldova, str. A. Mateevici 99.A, or. Stăuceni, is our official exclusive distributor for all sales and after-sales services.

Furthermore, it is authorized to fulfill warranty and post-warranty obligations for vehicles provided by our company within the territory of the Republic of Moldova.

This certificate is issued to confirm the exclusive distributor status and the authorization of the aforementioned activities.

Signed,

Risen Machinery
General Director
Andy Ding

Date of issuance: 09.12.2024

Number: RSJIT241209E

Official signature and stamp:

