

MEDIVATORS™ ISA™

Endoscope Reprocessor



USER MANUAL

MODEL:
MEDIVATORS™ ISA™

TYPE:
WASHER-DISINFECTOR

INTENDED PURPOSE

Medical device intended for washing and cold chemical disinfection of rigid and flexible endoscopes.

The MD must NOT be used for any purposes not envisaged by the manufacturer and/or NOT reported in the present manual.

THE MAIN CHARACTERISTICS OF THE MEDIVATORS™ ISA™ ENDOSCOPE REPROCESSOR INCLUDE:

- Configuration conforming with the current European regulations and international standards EN ISO 15883-1/4 and CEN ISO/TS 15883-5.
- PC All in one with touch screen dedicated to the user interface and recording of the cycle parameters.
- A spacious basin for the reprocessing of endoscopes and/or endoscopic accessories.
- The possibility to have a drying cycle with alcohol (optional).
- The use of safe and validated single shot detergent and sterilizing/disinfectant chemical solutions, compatible with the various brands of endoscope available on the market.
- A validated process (equipment and chemicals) for use at room temperature.
- Continuous monitoring of the channel pressure, the flow rates in the channels and the general parameters throughout the entire cycle.
- A rapid and unique interconnecting system for the endoscope channel connectors Warranting the proper control of flow rates in the endoscope channels.
- Operator and endoscope recognition system using RFID (Radio-Frequency Identification).
- The possibility to perform the self-disinfection cycle using programmable automatic start-up.
- Air filtration system capable of Warranting the complete sterility of the process, and dual filter system for the water feed (0.45 µm - 0.1 µm).
- Traceability of the processes in hardcopy format (using the integrated printer) and electronic format (using complete traceability management software).
- Opening of the lid by pedal (hands-free).
- Capable of adapting to all hospital situations, even in small spaces, thanks to compact size.
- Acoustic and visual alarm signals with a description of the type of fault to allow the operator to immediately identify the type of problem.
- Tanks for the detergent/decontaminant and high level sterilizing/disinfectant solutions A and B, that are safe with no harmful emissions.



The equipment must only be used by qualified personnel and only after having attended a training course organized by the manufacturer or by personnel authorized by the manufacturer.

ENDOSCOPIC CHANNEL CONNECTION



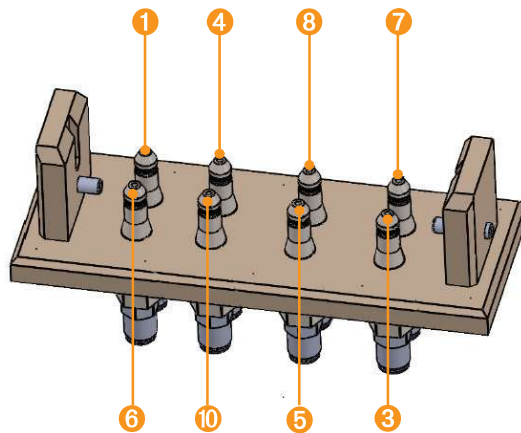

The MEDIVATORS™ ISA™ Endoscope Reprocessor is fitted with a connection system in order to allow the rapid and unambiguous connection of the endoscope channels with the relevant connectors.

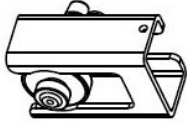

Position	Name in the software	Channel
1	Leak Test	Leak Test
3	Channel 7	Elevator Channel
4	Channel 2	Jet Channel
5	Channel 3	Water Channel
6	Channel 6	Extra Channel
7	Channel 4	Air 2 Channel
8	Channel 5	Biopsy Channel
10	Channel 1	Suction Channel

The mobile connection block supplied with the MEDIVATORS™ ISA™ Endoscope Reprocessor comes with a range of kits for connecting to endoscopes from the major manufacturers (OLYMPUS®, FUJIFILM™, PENTAX®, KARL STORZ etc.), supplied according to the client's needs.

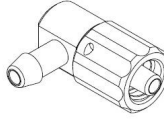
EXAMPLE OF CONNECTORS FOR ENDOSCOPE CHANNELS

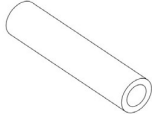
Leak Test connection	
Biopsy channel connection	
Air channel connection	
Auxiliary or elevator channel connection	
Channel separator connection (buttons)	
Air-water connection	
Suction channel connection	



To identify the type of connector needed to reprocess the various types of endoscopes, contact your authorized **Cantel Medical** or **Medivators** representative.

REMOVING THE ENDOSCOPES FROM THE BASIN

To correctly remove the endoscope from the basin, proceed as reported below:

1. Wear personal PPE.
2. Proceed with operator recognition by bringing the operator tag close to the RFID A reader as reported below.
3. Disconnect the connecting tubes from the relevant endoscope channels.
4. Disconnect the mobile interconnection block from that fixed to the basin by turning the red lever on the mobile interconnection block clockwise until open.
5. Remove the endoscope from the basin.
6. Close the basin cover using the pedal (black band present on the lower part of the equipment). This will be followed by a short acoustic signal confirming the command has been implemented.

RFID A-OPERATOR TAG



ENDOSCOPE TREATMENT CYCLES

The MEDIVATORSM ISASM Endoscope Reprocessor has numerous cycles that are validated for the treatment of endoscopes, as reported in the following table (Table 1).

The self-disinfection cycle refers to sterilization of the circuit and the water filters.

Cycle	Duration	Description
Complete Disinfection	20 min	Washing and disinfection cycle
Complete Double Clean Disinfection	25 min	Double Washing and disinfection cycle
Complete Disinfection Austrian	50 min	Intensive Washing and disinfection cycle
Disinfection	12 min	Disinfection cycle only, with no cleaning
Self-Disinfection	20 min	Internal circuit sterilization cycle

Table 1. The MEDIVATORSSM ISASM Endoscope Reprocessor pre-set cycles

It is also possible to perform a final drying cycle using isopropyl alcohol (optional).

STEPS IN THE “COMPLETE DISINFECTION CYCLE”

1. Initial leak test (with monitoring throughout the entire cycle)
2. Water and detergent loading
3. Cleansing
4. Discharge
5. Water loading
6. Rinsing
7. Water discharge
8. Water and disinfectant solution loading
9. Disinfection
10. Solution discharge
11. Water loading
12. Rinsing
13. Water discharge
14. Endoscope channel drying

duration:
20 minutes



STEPS IN THE “COMPLETE DOUBLE CLEAN DISINFECTION CYCLE”

1. Initial leak test (with monitoring throughout the entire cycle)
2. Water and detergent loading
3. Cleaning
4. Drain
5. Water loading
6. Rinsing
7. Water Drain
8. Water and detergent loading
9. Cleaning
10. Drain
11. Water loading
12. Rinsing
13. Water Drain
14. Water and disinfectant solution loading
15. Disinfection
16. Solution Drain
17. Water loading
18. Rinsing
19. Water Drain
20. Endoscope channel drying

duration:
25 minutes



INTERNAL COMPONENTS

Figure 3

Viewed from above the basin of
the MEDIVATORS™ ISA™
Endoscope Reprocessor.

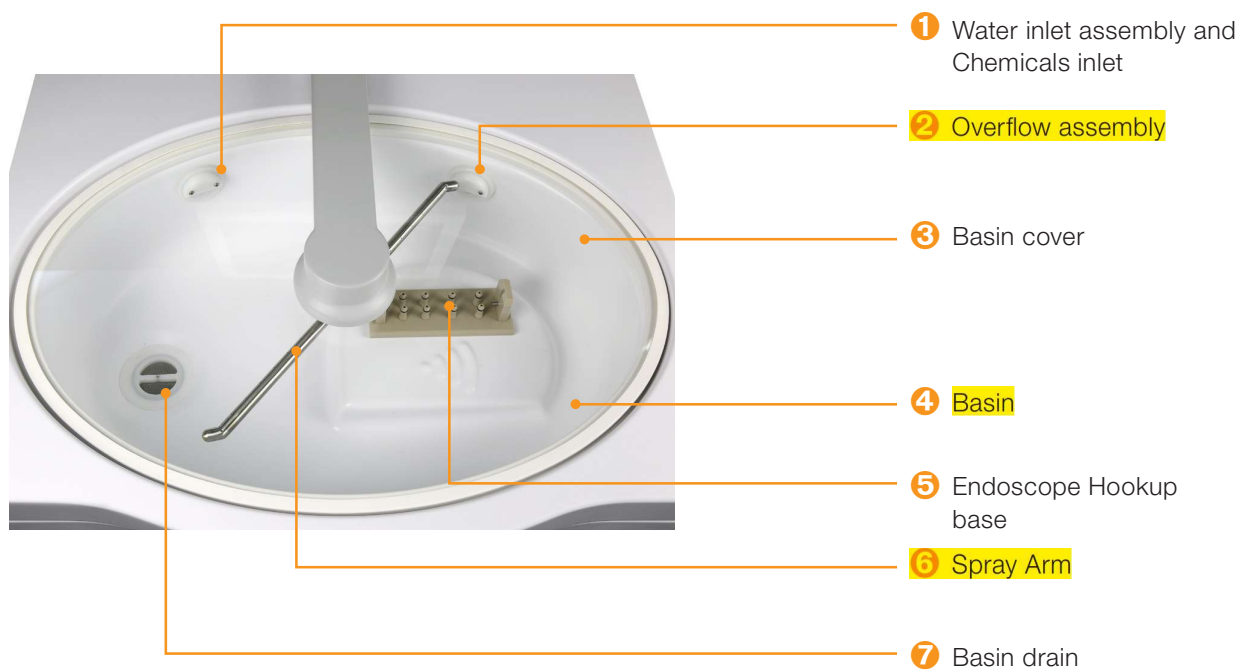

BASIN COVER CONTROL PEDAL

The control footswitch allows the operator to open and close the lid without the use of hands, thus aiding easy insertion of the endoscope inside.

Once the pedal is pressed, the equipment emits an acoustic warning signal confirming the execution of the command.



▶ Type of alarm	▶ Cause	▶ Solution
ALARM TIME-OUT STERILANT 2 LOAD	<ol style="list-style-type: none"> 1. Part B bottle empty 2. Part B tube kinked 3. Part B tube broken or not correctly fixed to the uptake 4. Part B valves V12, V12a or V12b fault. 5. Parta B sensor SL12 fault 6. Delivery valve V2a fault 7. In line valve V17 fault 8. Main pump P1 fault 	<ol style="list-style-type: none"> 1. Check the Part B bottle isn't empty 2. Check Part B tube and uptake 3. Restart the cycle 4. Contact your Cantel Service Representative
ALARM TIME-OUT ALCOHOL LOAD	<ol style="list-style-type: none"> 1. Alcohol bottle empty 2. Alcohol tube kinked 3. Alcohol tube broken or not correctly fixed to the uptake 4. Alcohol pump P4 fault. 5. Alcohol flowmeter FT19 fault 6. Alcohol valve V19 fault 7. Alcohol check valve VR9 fault 	<ol style="list-style-type: none"> 1. Check the detergent bottle isn't empty 2. Check detergent tube and uptake 3 Try to restart the cycle 4. Contact Your Cantel Service Representative
TIME-OUT ALARM DRAIN SOLUTION 1	<ol style="list-style-type: none"> 1. Part A valves V11, V11a or V11b fault. 2. Parta A sensor SL11 fault 3. Delivery valve V2a fault 4. In line valve V17 fault 5. Main pump P1 fault 	<ol style="list-style-type: none"> 1. Contact your Cantel Service Representative
TIME-OUT ALARM DRAIN SOLUTION 2	<ol style="list-style-type: none"> 1. Part B valves V12, V12a or V12b fault. 2. Parta A sensor SL12 fault 3. Delivery valve V2a fault 4. In line valve V17 fault 5. Main pump P1 fault 	<ol style="list-style-type: none"> 1. Contact your Cantel Service Representative
DOSING SYSTEM ALARM	<ol style="list-style-type: none"> 1. Sensor Part A SL11 fault 2. Sensor Part B SL12 fault 	<ol style="list-style-type: none"> 1. Contact your Cantel Service Representative
SUCTION CHANNEL DISCONNECTED ALARM	<ol style="list-style-type: none"> 1. Suction channel disconnected from the endoscope 2. Hook-up Suction tube broken 3. Hook-up not correctly fix on the basin 4. Channel separator not correctly fixed on the endoscope. 5. Wrong endoscope selection 6. Suction flowmeter FT10 fault 7. Suction valve V10 fault 8. Flow reducer R2 fault 9. In line check valve VR8 fault 	<ol style="list-style-type: none"> 1. Check Endoscope selection 2. Check hook-up and tube 3. Check channels separator 4. Restart the cycle 5. Contact your Cantel Service Representative
SUCTION CHANNEL BLOCKED ALARM	<ol style="list-style-type: none"> 1. Suction channel blocked on the endoscope 2. Hook-up Suction tube kinked 3. Wrong endoscope selection 4. Suction flowmeter FT10 fault 5. Suction valve V10 6. Main pump P1 fault 7. Drain valve V3 fault 8. Flow reducer R2 fault 9. In line check valve VR8 fault 	<ol style="list-style-type: none"> 1. Check Endoscope selection 2. Check kinked tube 3. Restart the cycle 4. Contact your Cantel Service Representative

▶ Type of alarm	▶ Cause	▶ Solution
JET/AUX CHANNEL DISCONNECTED ALARM	1. Jet/Aux channel disconnected from the endoscope 2. Hook-up Jet/Aux tube broken 3. Hook-up not correctly fix on the basin 4. Channel separator not correctly fixed on the endoscope. 5. Wrong endoscope selection 6. Jet/Aux flowmeter FT9 fault 9. Suction valve V9 fault 8. Flow reducer R2 fault 9. In line check valve VR8 fault	1. Check Endoscope selection 2. Check hook-up and tube 3. Check channels separator 4. Restart the cycle 5. Contact your Cantel Service Representative
JET/AUX CHANNEL BLOCKED ALARM	1. Jet/Aux channel blocked on the endoscope 2. Hook-up Jet/Aux tube kinked 3. Wrong endoscope selection 4. Jet/Aux flowmeter FT9 fault 5. Jet/Aux valve V9 6. Main pump P1 fault 7. Drain valve V3 fault 8. Flow reducer R2 fault 9. In line check valve VR8 fault	1. Check Endoscope selection 2. Check kinked tube 3. Restart the cycle 4. Contact your Cantel Service Representative
WATER CHANNEL DISCONNECTED ALARM	1. Water channel disconnected from the endoscope 2. Hook-up Water tube broken 3. Hook-up not correctly fix on the basin 4. Channel separator not correctly fixed on the endoscope. 5. Wrong endoscope selection 6. Water flowmeter FT8 fault 7. Suction valve V8 fault 8. Flow reducer R2 fault 9. In line check valve VR8 fault	1. Check Endoscope selection 2. Check hook-up and tube 3. Check channels separator 4. Restart the cycle 5. Contact your Cantel Service Representative
WATER CHANNEL BLOCKED ALARM	1. Water channel blocked on the endoscope 2. Hook-up Water tube kinked 3. Wrong endoscope selection 4. Jet/Aux flowmeter FT8 fault 5. Water valve V8 6. Main pump P1 fault 7. Drain valve V3 fault 8. Flow reducer R2 fault 9. In line check valve VR8 fault	1. Check Endoscope selection 2. Check kinked tube 3. Restart the cycle 4. Contact your Cantel Service Representative

▶ Type of alarm	▶ Cause	▶ Solution
AIR CHANNEL DISCONNECTED ALARM	1. Air channel disconnected from the endoscope 2. Hook-up Air tube broken 3. Hook-up not correctly fix on the basin 4. Channel separator not correctly fixed on the endoscope. 5. Wrong endoscope selection 6. Air flowmeter FT7 fault 7. Suction valve V7 fault 8. Flow reducer R2 fault 9. In line check valve VR8 fault	1. Check Endoscope selection 2. Check hook-up and tube 3. Check channels separator 4. Restart the cycle 5. Contact your Cantel Service Representative
AIR CHANNEL BLOCKED ALARM	1. Air channel blocked on the endoscope 2. Hook-up Air tube kinked 3. Wrong endoscope selection 4. Air flowmeter FT7 fault 5. Extra valve V7 6. Main pump P1 fault 7. Drain valve V3 fault 8. Flow reducer R2 fault 9. In line check valve VR8 fault	1. Check Endoscope selection 2. Check kinked tube 3. Restart the cycle 4. Contact your Cantel Service Representative
BIOPSY CHANNEL DISCONNECTED ALARM	1. Biopsy channel disconnected from the endoscope 2. Hook-up Biopsy tube broken 3. Hook-up not correctly fix on the basin 4. Channel separator not correctly fixed on the endoscope. 5. Wrong endoscope selection 6. Biopsy flowmeter FT6 fault 7. Biopsy valve V6 fault 8. Flow reducer R2 fault 9. In line check valve VR8 fault	1. Check Endoscope selection 2. Check hook-up and tube 3. Check channels separator 4. Restart the cycle 5. Contact your Cantel Service Representative
BIOPSY CHANNEL BLOCKED ALARM	1. Biopsy channel blocked on the endoscope 2. Hook-up Biopsy tube kinked 3. Wrong endoscope selection 4. Biopsy flowmeter FT6 fault 5. Suction valve V6 6. Main pump P1 fault 7. Drain valve V3 fault 8. Flow reducer R2 fault 9. In line check valve VR8 fault	1. Check Endoscope selection 2. Check kinked tube 3. Restart the cycle 4. Contact your Cantel Service Representative

▶ Type of alarm	▶ Cause	▶ Solution
EXTRA CHANNEL DISCONNECTED ALARM	1.Extra channel disconnected from the endoscope 2.Hook-up Extra tube broken 3. Hook-up not correctly fix on the basin 4. Channel separator not correctly fixed on the endoscope. 5. Wrong endoscope selection 6. Extra flowmeter FT5 fault 7. Extra valve V5 fault 8. Flow reducer R2 fault 9. In line check valve VR8 fault	1. Check Endoscope selection 2. Check hook-up and tube 3. Check channels separator 4. Restart the cycle 5. Contact your Cantel Service Representative
EXTRA CHANNEL BLOCKED ALARM	1.Extra channel blocked on the endoscope 2.Hook-up Extra tube kinked 3. Wrong endoscope selection 4. Extra flowmeter FT5 fault 5. Extra valve V5 6. Main pump P1 fault 7. Drain valve V3 fault 8. Flow reducer R2 fault 9. In line check valve VR8 fault	1. Check Endoscope selection 2. Check kinked tube 3. Restart the cycle 4. Contact your Cantel Service Representative
ELEVATOR CHANNEL DISCONNECTED ALARM	1.Elevator channel disconnected from the endoscope 2.Hook-up Elevator tube broken 3. Hook-up not correctly fix on the basin 4. Channel separator not correctly fixed on the endoscope. 5. Wrong endoscope selection 6. Elevator pressure transducer TP7 fault 7. Elevator valve VPP1 fault 8. Main pump P1 fault 9. Flow reducer R2 fault 10. In line check valve VR8 fault	1. Check Endoscope selection 2. Check hook-up and tube 3. Check channels separator 4. Restart the cycle 5. Contact your Cantel Service Representative
ELEVATOR CHANNEL BLOCKED ALARM	1.Elevator channel blocked on the endoscope 2.Hook-up Elevator tube kinked 3. Wrong endoscope selection 4. Elevator pressure transducer TP7 fault 5. Elevator valve VPP1 6. Main pump P1 fault 7. Drain valve V3 fault 8. Flow reducer R2 fault 9. In line check valve VR8 fault	1. Check Endoscope selection 2. Check kinked tube 3. Restart the cycle 4. Contact your Cantel Service Representative

- g. SWITCH OFF THE PC: it is obligatory that this button be used to shut-down the PC.

Any other PC shut-down procedure could cause damage to the PC itself, which DOES NOT fall within the scope of the manufacturer's Warranty.

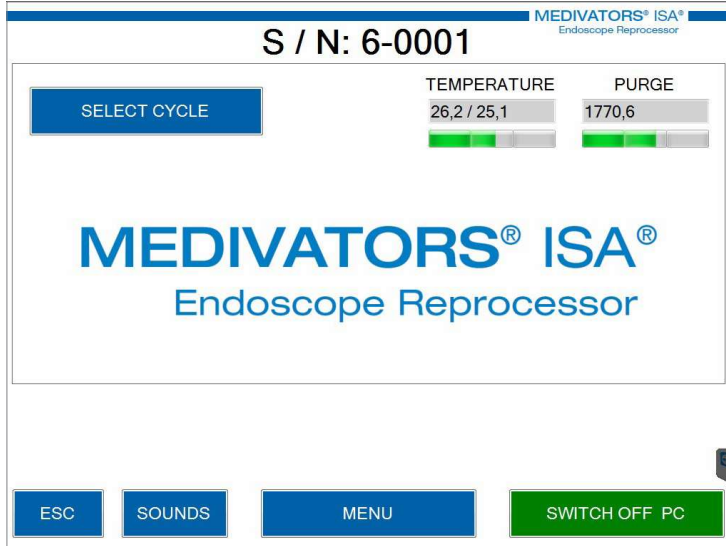

TANK REPLACEMENT PROCEDURE

During the cycle, if the equipment detects a lack or partial load for one of the products, it informs the user of the need to replace the relevant tank by means of visual and acoustic messages.

This warning is managed so as to allow the

operator to be able to replace the corresponding product tank without the need to interrupt and restart the cycle from the start.

When an absence of product load is detected, the screen displays one of the following messages:

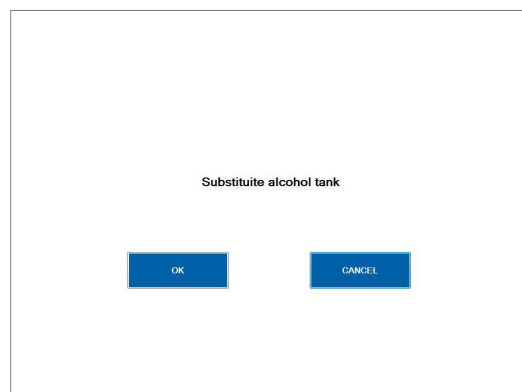
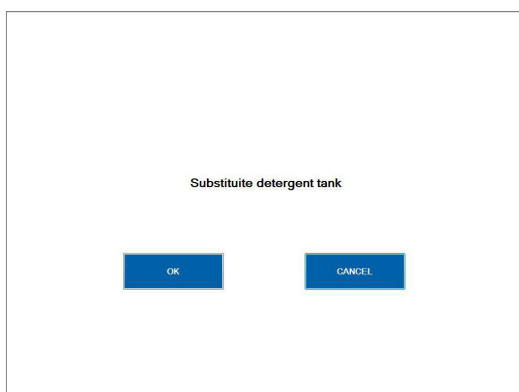
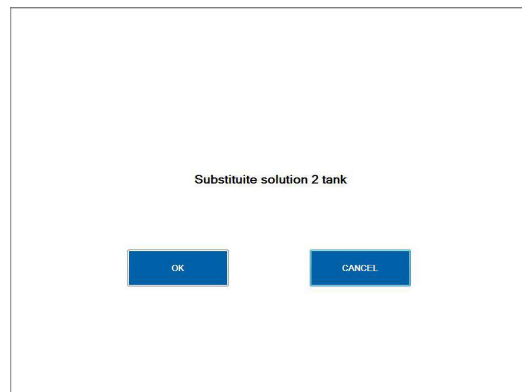
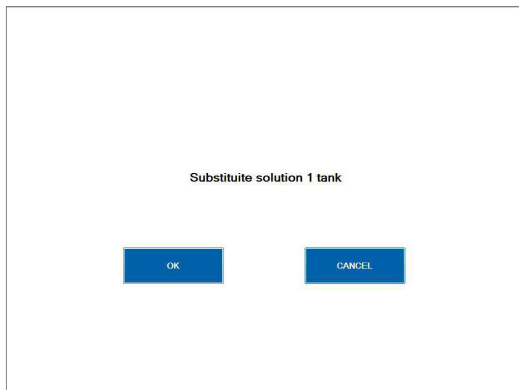

DESCRIPTION OF THE VALIDATED CHEMICAL SOLUTIONS

The MEDIVATORS™ ISA™ Endoscope Reprocessor uses specific and validated chemical solutions in

order to obtain an effective cleaning and disinfection process.

In particular:

FOR THE CLEANSING PHASE

One of the following solutions can be used:

ISACLEAN™ AER Detergent/Decontaminant:

- For the cleaning phase, MEDIVATORS™ ISA™ Endoscope Reprocessor uses ISACLEAN™ AER Detergent / Decontaminant, a medical device specific for the removal of microbial biofilms.
- ISACLEAN™ AER Detergent / Decontaminant is available in 1 L or 5 L tanks.
- A 1 L tank of ISACLEAN™ AER Detergent / Decontaminant allows the execution of approx. 62 cycles.
- A 5 L tank of ISACLEAN™ AER Detergent / Decontaminant allows the execution of approx. 312 cycles.

PROTEAZONE™ PLUS Detergent and Cleaner:

- For the cleaning stage, MEDIVATORS™ ISA™ Endoscope Reprocessor uses PROTEAZONE™ PLUS Detergent and Cleaner, specific for the removal of microbial biofilms.
- PROTEAZONE™ PLUS Detergent & Cleaner is available in 5 L tanks.
- A 5 L tank of PROTEAZONE™ PLUS Detergent/Decontaminant allows the execution of approx. 147 cycles.

Please contact your local representative for cycles definition and detergent/disinfectant setting.

FOR THE DISINFECTION PHASE:

ISASPOR™ SINGLE SHOT High-Level Disinfectant/Sterilant.

- For the disinfection cycle, the MEDIVATORS™ ISA™ Endoscope Reprocessor uses ISASPOR™ SINGLE SHOT High-Level Disinfectant/Sterilant, a certified medical device (CE 0051).
- When using ISASPOR™ SINGLE SHOT HLD/ Sterilant the device consists of a tank containing solution A (5% peracetic acid) and a tank containing solution B (containing ISAZONE™ Molecule*) ingredient.
- ISASPOR™ SINGLE SHOT HLD/Sterilant is available in 10 L tanks (10 L Solution A + 10 L Solution B) or in 5 L tanks (5 L Solution A + 5 L Solution B).
- A 5 L tank of ISASPOR™ SINGLE SHOT HLD/ Sterilant allows the execution of approx. 26 cycles.
- A 10 L tank of ISASPOR™ SINGLE SHOT HLD/ Sterilant allows the execution of approx. 52 cycles.
- The detergent and High-Level Disinfectant/sterilizing solution used for each cycle are single use (single shot).
- The medical device distribution system ensures that, for each cycle, the correct amount of concentrated product is withdrawn from the tanks and ensures that said products are injected into the basin containing the endoscope.

*molecule patented by Cantel Medical (Italy) S.r.l

EXTERNAL COMPONENTS

Figure 2
Rear view of the MEDIVATORS™ ISA™
Endoscope Reprocessor.



END OF CYCLE REPORT - ARCHIVING PROCEDURES

The MEDIVATORS™ ISA™ Endoscope Reprocessor system records all the information relating to the cycles performed on its own hard disk, creating an electronic archive that can be consulted at any time. It is also equipped with a built-in printer which automatically prints the cycle report on completion of the cycle. The report is a document that is essential for cycle validation and must always be filed.

Parameters included in the print-out:

- MEDIVATORS™ ISA™ serial number
- Cycle start date and time
- Instrument data (category-s/n)
- Physician (optional)
- Patient (optional)
- Operator
- Type of cycle performed
- Cycle progressive number
- Cycle steps with relevant contact times
- Cycle outcome

A sample report relating to a correctly concluded cycle is reported below:

```

MEDIATORS ISA
-----
SERIAL NUMBER: 6-0006
CYCLE START: 03/12/2015 11:06:32
INSTRUMENT: GIF-Q165
CATEGORY: GASTROSCOPE
SERIAL NUMBER: A012345
OPERATOR: VERDI
PHYSICIAN: ROSSI
PATIENT: 12345
CYCLE TYPE: COMPLETE DISINFECTION
CYCLE NUMBER: 27
11:06:33 LEAK TEST
11:06:33 WATER LOAD
11:06:53 DETERGENT LOAD
11:07:10 CLEANING (120s,14°C)
11:09:16 DRAIN
11:10:41 WATER LOAD
11:11:16 RINSE
11:12:27 DRAIN
11:13:52 WATER LOAD
11:14:12 STERILANT 1 LOAD
11:15:15 DISINFECTION (180s,14°C)
11:18:21 DRAIN
11:19:46 WATER LOAD
11:20:21 RINSE
11:21:31 DRAIN
11:22:56 PURGE
11:24:04 CYCLE END

11:24:06 REGULAR CYCLE

```

IT REQUIREMENTS

IT Network Features and requirements

MEDIVATORS™ ISA™ Automated Endoscope Reprocessor can be connected to an IT network to provide optional features

Network features

1. Hospital Information System (HIS) output.

An HIS output file can be sent to a network share at the end of a cycle. This data can be used by Track and Trace systems to record cycle data.

2. Data backup

Machine data can be manually backed up to a mapped network drive or USB removable media.

Operating environment requirements

1. MEDIVATORS™ ISA™ Automated Endoscope Reprocessor should be installed and operated in a controlled access environment.
2. MEDIVATORS™ ISA™ Automated Endoscope Reprocessor should be connected to a secure, controlled access IT network
3. Access should be restricted to authorized personnel only
4. Personnel should be provided the minimum access privileges required to perform their intended function.

For further information please contact Customer Services

PRINTER

The MEDIVATOR™ ISA™ Endoscope Reprocessor is equipped with an integrated printer fitted as standard, facing frontwards and located to the upper left of the device.

On completion of each reprocessing cycle, the device automatically prints a report containing the information relating to the cycle: **cycle start date and time, endoscope ID code, medical operator (optional), patient (optional), type of cycle executed, all the various phases conducted, indicating the times and cycle outcome.**



Reprocessing report



5 Printer

FILTRATION SYSTEMS

The MEDIVATOR™ ISA™ Endoscope Reprocessor is equipped with a water and air filtration system capable of Warranting the efficacy of the reprocessing cycles performed.

Water filter

- The device is equipped with a dual water filtration system:
- 0.45 micron water filter capsule;
- 0.1 micron water filter capsule;
- A pair of water filters are supplied with the equipment on installation.

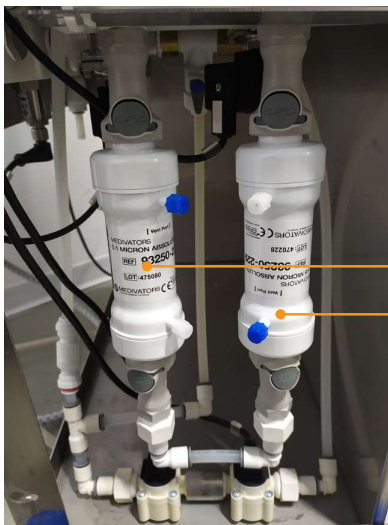

- 1 0.1 MICRON
- 2 0.45 MICRON

Code	Description
93250-222	Water Filter Kit Colder (0.1 µm + 0.45 µm)



Replacement of the water filters must be performed by qualified technical staff authorized by the manufacturer. Otherwise the efficacy of the washing and disinfection process is NOT warranted.

Any damage resulting from failure to replace the water filters and/or the use of NON ORIGINAL filters and/or operations performed by NON authorized personnel will invalidate any type of Warranty. The use of filters other than those indicated by the manufacturer does NOT Warranty the efficacy of the washing and disinfection processes.