

T 2628 EN

Type 44-0 B Steam Pressure Reducing Valve

Series 44 Self-operated Pressure Regulators



Application

Set points from **0.2 to 20 bar** · Valves **G ½**, **G ¾** and **G 1** as well as **DN 15, 25, 40** and **50** · Pressure rating **PN 25** · Suitable for steam up to **200 °C**

The valve **closes** when the **downstream** pressure rises.

The regulators consist of a valve and an integrated actuator with an operating bellows and a set point adjuster.

Special features

- Low-maintenance proportional regulators requiring no auxiliary energy
- Wide set point range and convenient set point adjustment
- Spring-loaded, single-seated valve without pressure balancing or plug balanced by a bellows
- Stainless steel operating bellows as operating element
- Compact design with particularly low overall height
- Valve body made of red brass, spheroidal graphite iron or stainless steel

Versions

Pressure regulators for set point ranges from 0.2 to 20 bar and valve body with female thread or flanged connections

Type 44-0 B Pressure Reducing Valve · Regulators with PN 25 valve suitable for steam up to 200 °C · Red brass or stainless steel body with screwed ends G ½, G ¾ and G 1 female thread (Fig. 1) · Stainless steel flanged body DN 15 and 25 (Fig. 3) · Spheroidal graphite iron flanged body DN 15, 25, 40 and 50 (Fig. 2)

Special versions

- Regulator prepared for pressure gauge or external control line connection (connecting thread G ½)
- Version with electric set point adjustment (up to G 1 or DN 25) for set points up to 10 bar
- Version with pneumatic set point adjuster (up to G 1 or DN 25)
- Version as differential pressure regulator (up to G 1 or DN 25)

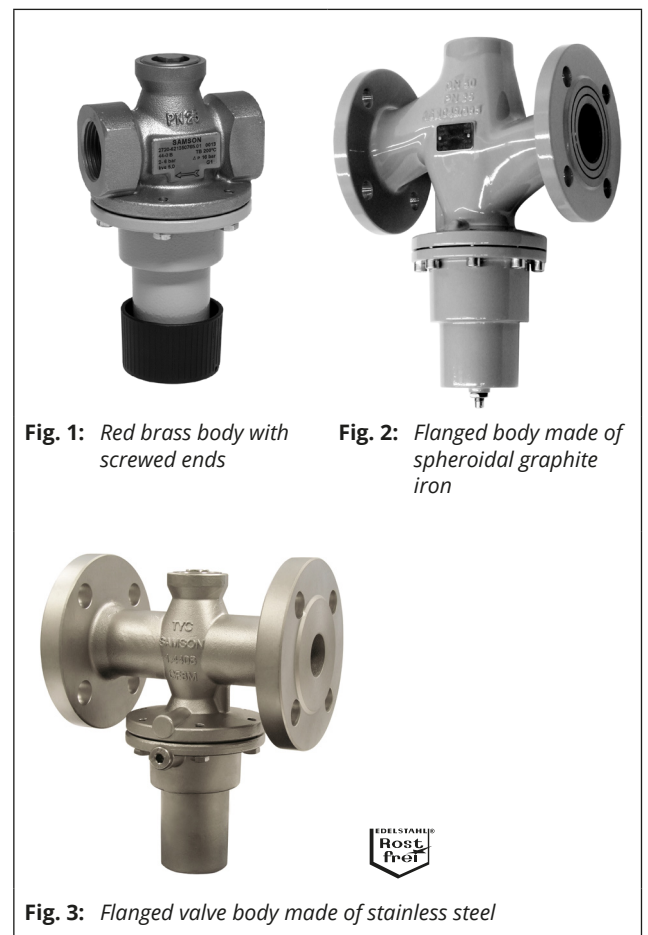

Principle of operation (see Fig. 4)

The medium flows through the valve in the direction indicated by the arrow. The position of the plug determines the flow rate across the area released between plug (2) and valve seat (3).

The Type 44-0 B Steam Pressure Reducing Valve is open when relieved of pressure. The valve closes when the downstream pressure (p_2) rises above the adjusted set point.

The pressure to be kept constant is transmitted through a borehole (4) in the valve body (1) to the operating bellows (5) where it is converted into a positioning force. It moves the valve plug depending on the spring rate of the set point springs (7) and the set point adjuster (8) or set point adjusting screw (9) (8 to 20 bar set point range and for version with stainless steel or spheroidal graphite iron body in DN 40/50).

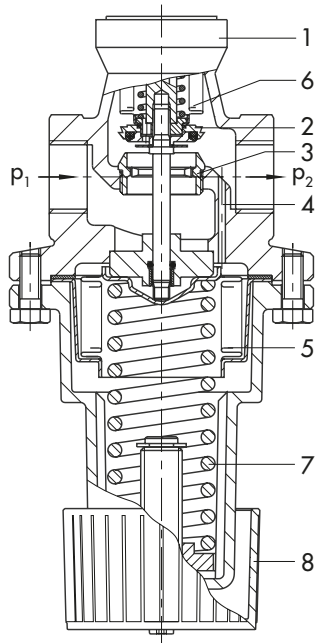

Type 44-0 B Pressure Reducing Valve · Body with screwed ends (female thread)

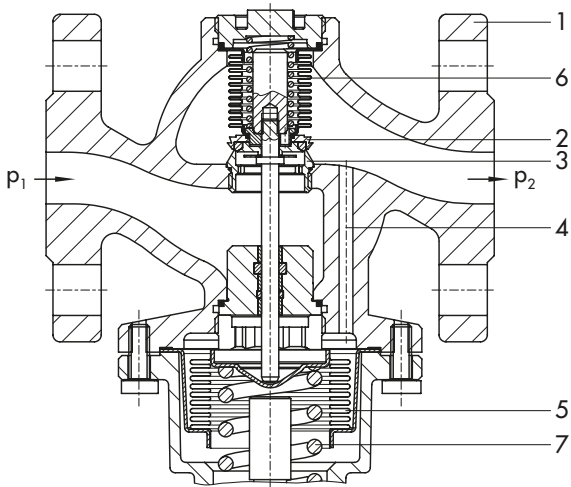

Type 44-0 B Pressure Reducing Valve · Flanged body made of spheroidal graphite iron

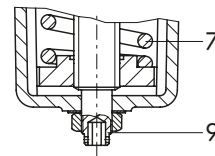

Set point adjustment at hexagonal socket head screw

Stainless steel/spheroidal graphite iron version (DN 40/50 only) and 8 to 20 bar set point range

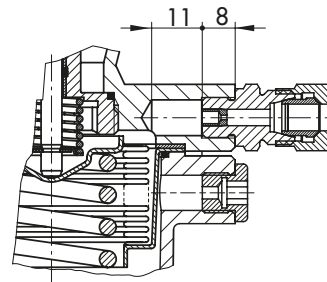

Special version in stainless steel

Connecting thread G 1/8 A for a pressure gauge or external control line · Dimensions in mm

- | | |
|---------------------------------|----------------------------------|
| 1 Valve body | 6 Balancing bellows |
| 2 Plug | 7 Set point spring |
| 3 Seat | 8 Set point adjuster (handwheel) |
| 4 Borehole for control pressure | 9 Set point screw |
| 5 Operating bellows | |

Fig. 4: Functional diagram

Table 1: Technical data · All pressures in bar (gauge)

Type 44-0 B Steam Pressure Reducing Valve		
Connection	Stainless steel/red brass body	Female thread G ½, G ¾, G 1
	Stainless steel body	Flanges DN 15 and 25
	Spheroidal graphite iron body	Flanges DN 15, 25, 40 and 50
Pressure rating		PN 25
Max. permissible temperature		200 °C
Max. perm. differential pressure Δp	G ½, G ¾, G 1 · DN 15, DN 25	10 ¹⁾ · 16 bar
	DN 40 and 50	8 bar
Leakage class according to IEC 60534-4		≤0.05 % of K _{V5} coefficient
Conformity		CE
Set point range (continuously adjustable)		0.2 to 2 bar · 1 to 4 bar · 2 to 6 bar · 4 to 10 bar · 8 to 20 bar ²⁾
Max. permissible ambient temperature		60 °C

¹⁾ With K_{V5} 1.0, 1.6, 2.0 and 2.5

²⁾ Set point range **not** for DN 40 and 50

Table 2: K_{V5} coefficients

Thread size · Screwed ends		G ½	G ¾	G 1	
K _{V5} coefficients ¹⁾	Standard version	1.6 ²⁾ · 3.2 ³⁾	2.0 ²⁾ · 4.0 ³⁾	2.5 ²⁾ · 5.0 ³⁾	
	Special version	1.0 ³⁾			
Nominal size (flange)		DN 15	DN 25	DN 40	DN 50
K _{V5} coefficients	Standard version	1.6 ¹⁾²⁾ · 3.2 ³⁾	2.5 ¹⁾²⁾ · 5.0 ³⁾	16.0 ³⁾	20.0 ³⁾
	Special version ¹⁾	1.0 ³⁾		8.0 ²⁾	

¹⁾ Unbalanced

²⁾ Metal seal

³⁾ Soft seal. Seal material: PTFE

Table 3: Materials · Material numbers according to DIN EN

Body	Red brass CC499K	Spheroidal graphite iron EN-GJS-400-18-LT	Stainless steel 1.4408
Seat	1.4305		1.4404
Plug	Brass (resistant to dezincification) with PTFE soft seal or metal seal (1.4404)		1.4404 with PTFE soft seal
Balancing bellows	1.4571		
Plug spring	1.4310		
Set point spring	1.7104 (55SiCr6)		1.4310
Operating bellows	1.4571		
Spring housing	EN AC-44300-DF (die-cast aluminum)		1.4408
Set point adjuster	Manual adjuster made of PTFE with 30 % glass fiber ¹⁾		Hexagonal socket head screw made of 1.4571

¹⁾ 8 to 20 bar set point range: hexagonal socket head screw made of 1.4571

Table 4: Dimensions and weights · Regulators with body with screwed ends

Red brass CC499K · Stainless steel 1.4408

Thread size · Screwed ends		G ½	G ¾	G 1
Female thread G		½"	¾"	1"
Overall length L		65 mm	75 mm	90 mm
Width across flats (A/F)		34 mm		46 mm
Height H1 ²⁾	Red brass CC499K	132 mm · 199 mm ¹⁾		
	Stainless steel 1.4408	155 mm · 222 mm ¹⁾		
Height H2	Red brass CC499K	48 mm		
	Stainless steel 1.4408	46 mm		
ØD		89 mm		
Weight, approx.		1.0 kg	1.1 kg	1.5 kg

¹⁾ Dimensions for regulators with 8 to 20 bar set point range or stainless steel body; set point adjustment at hexagonal socket head screw

²⁾ + min. 50 mm distance for set point adjustment

Table 5: Dimensions and weights · Regulators with flanged valve body

Spheroidal graphite iron EN-GJS-400-18-LT · Stainless steel 1.4408

Nominal size (flange)	DN 15	DN 25	DN 40	DN 50
Overall length L	130 mm	160 mm	200 mm	230 mm
Height H1 ¹⁾	155 mm		245 mm	
Height H2	46 mm		95 mm	
ØD	89 mm			
Weight, approx.	2.6 kg	4.2 kg	7 kg	8 kg

¹⁾ + min. 50 mm distance for set point adjustment

Dimensions of the regulators in mm

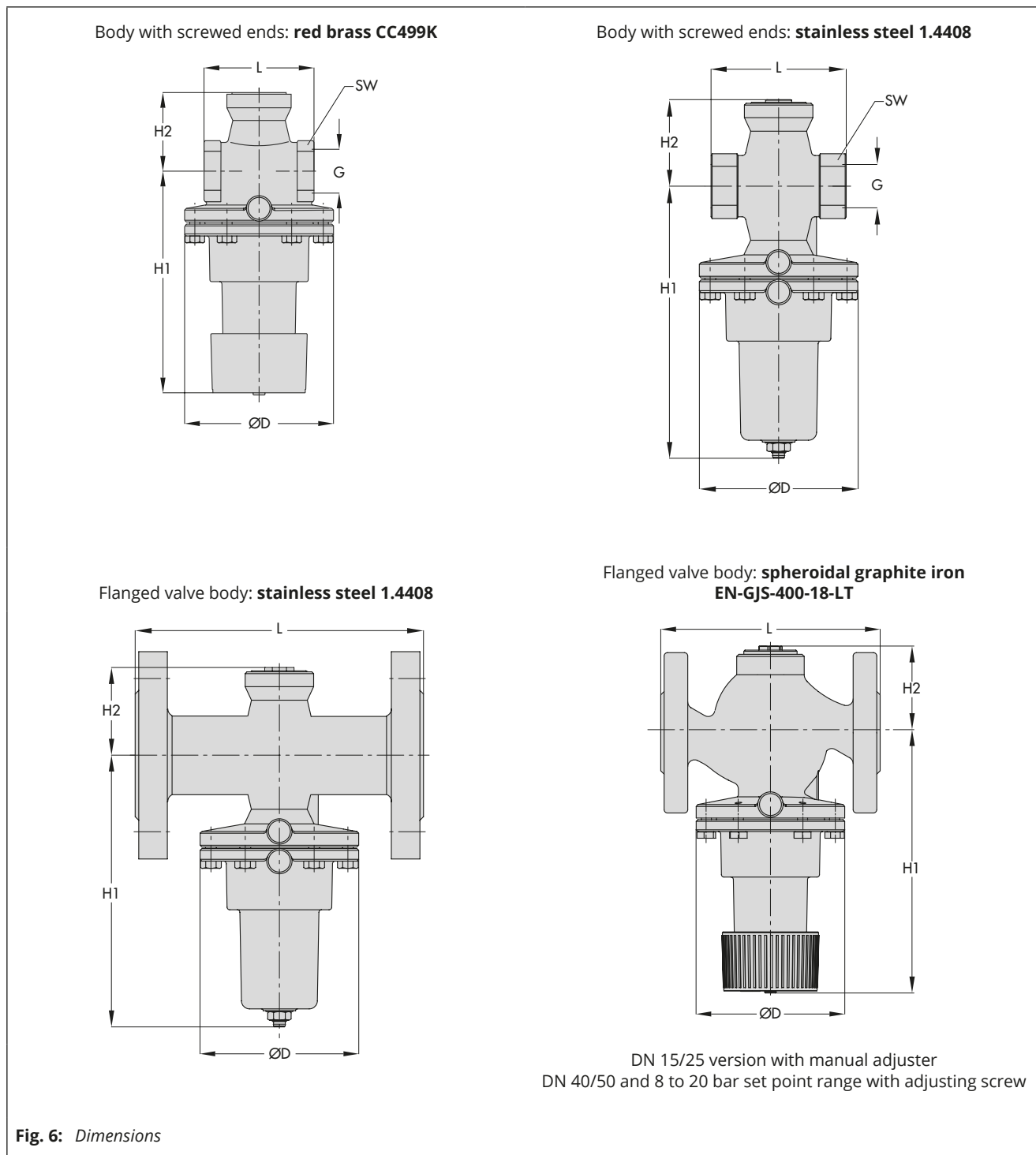

Fig. 6: Dimensions

Installation

The following applies:

- The direction of flow must match the direction indicated by the arrow on the body.
- Install the valve in horizontal pipelines with the actuator housing suspended downward (set point adjuster facing down)

Further details can be found in ► EB 2626-1.

Flow rate diagram for water

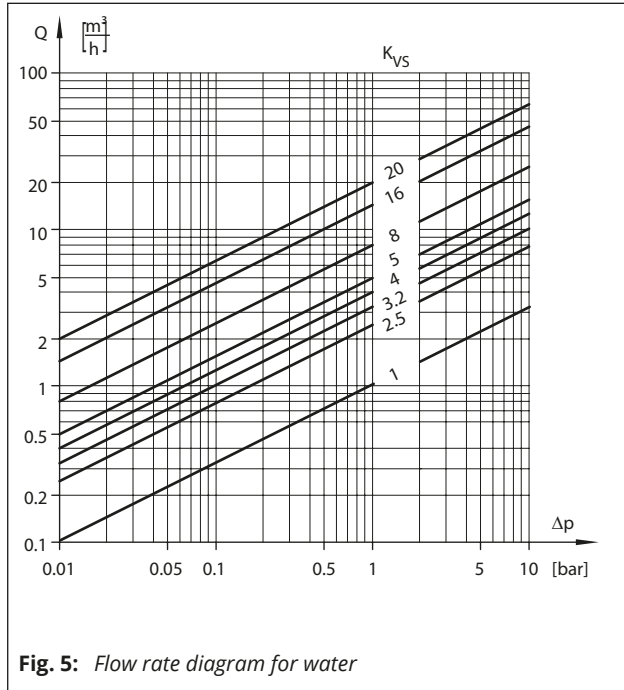

Ordering text

Type 44-0 B Steam Pressure Reducing Valve

Body material: red brass, stainless steel or spheroidal graphite iron

Version with screwed ends G ... or flanged valve body DN ...

Set point range ... bar

K_{VS} coefficient ...

Optionally, special version

Sizing the Type 44-0 B Steam Pressure Reducing Valve

To size the Type 44-0 B Steam Pressure Reducing Valve, the steam charts (sizing characteristics with valve characteristics) for saturated steam are provided.

This chart together with the additional specifications on the upstream pressure p_1 , downstream pressure p_2 and the required steam flow rate can be used to find the right valve for the Type 44-0 B Regulator using the valve characteristics in the graph.

To find the right valve, observe the diagrams on flow velocity (Fig. 7) and valve load (Fig. 8)

Select the largest of the determined values as the nominal size for the Type 44-0 B Regulator.

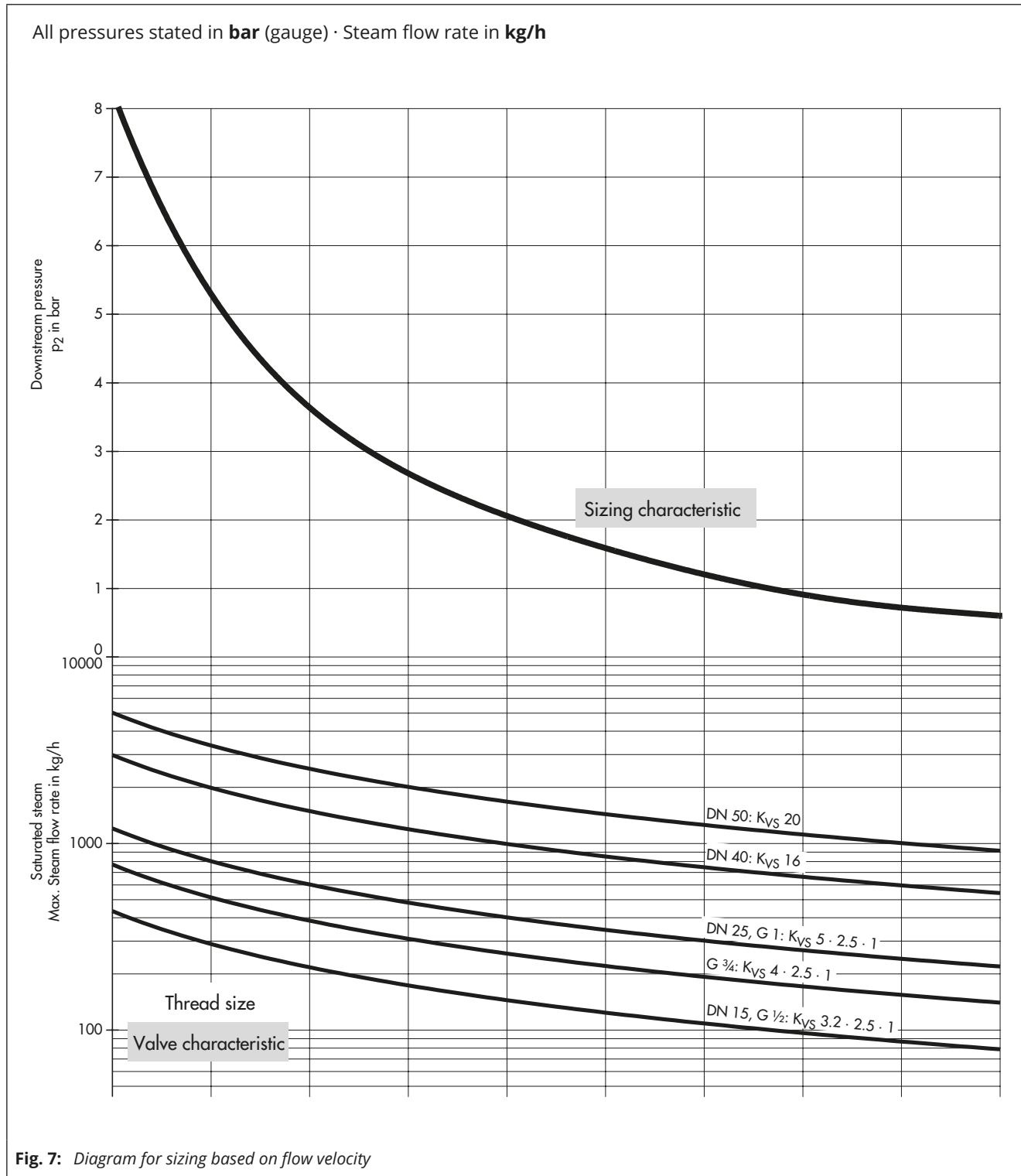

Fig. 7: Diagram for sizing based on flow velocity

All pressures stated in **bar** (gauge) · Steam flow rate in **kg/h**

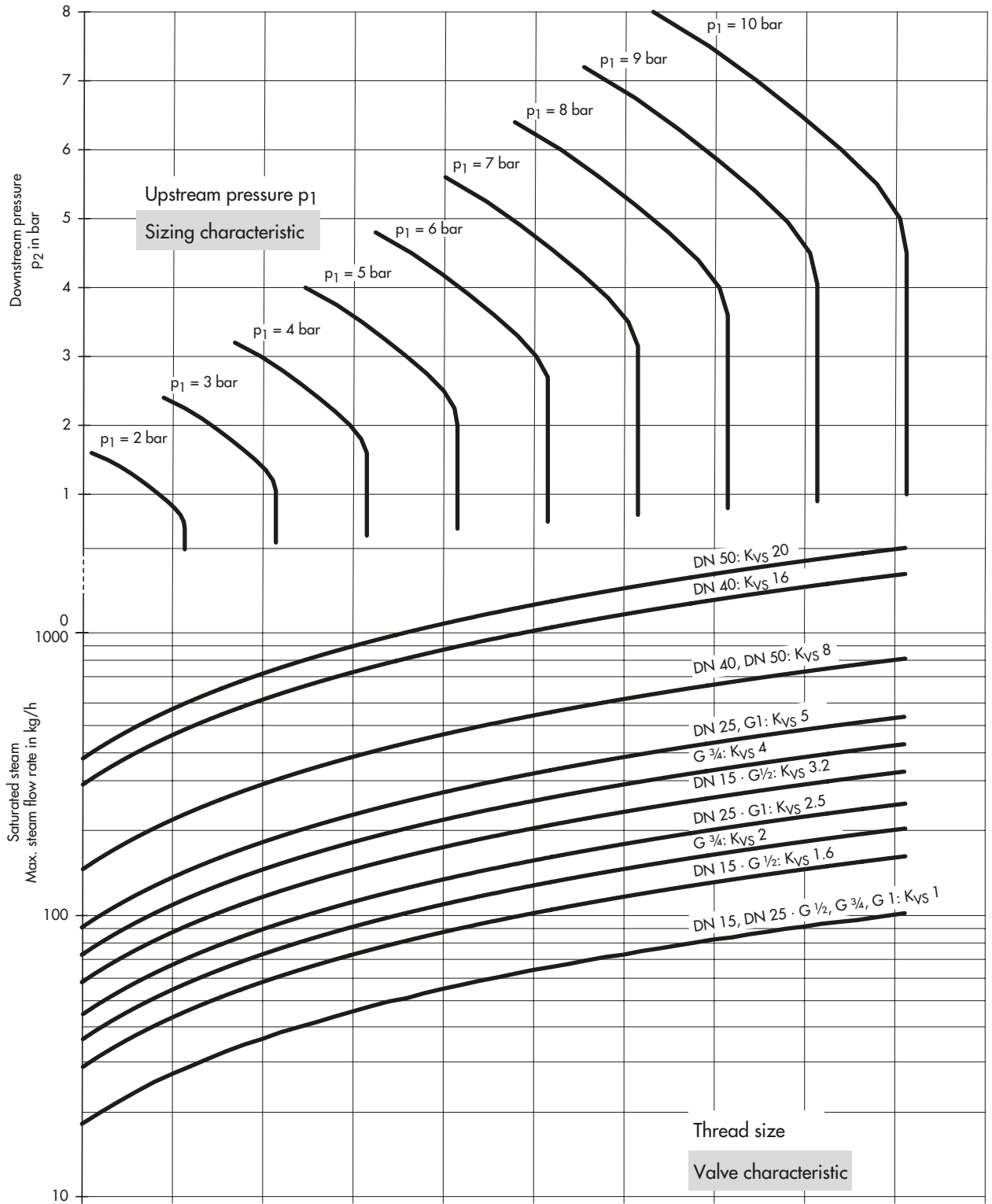

Fig. 8: Diagram for sizing based on valve load

