

ESKA

Gas Technologies

ERG-S/SE Series



ESKA

Sakarya 1. Organize Sanayi Bölgesi Mah. 11. Cad. No: 6-8, Arifiye/Sakarya/Türkiye
Phone : +90 (264) 502 54 34-35-83 Fax : +90 (264) 502 54 84 E-mail : info@eskavalve.com

www.eskavalve.com

Why ESKA?

With a deep understanding of the need for manufacturers to be close to gas distribution companies understanding their requirements and providing tailored solutions, ESKA grew to become a leading manufacturer of gas stream equipment. We start every day with a belief that change is constant, and the flexibility to follow that change and provide up to date solutions is crucial in the energy sector.

We manufacture gas stream equipment that are designed based on the needs of our partners. We strive to help gas distribution companies provide safe energy to their clients and to assist our partners with flexible business models that promote mutual growth.

Our commitment is to continually improve our products, ensuring the highest standards of safety and quality at an affordable cost, protecting end users while supporting our partners' success.



60 Years Know-how



Global Reach in 65 Countries



Localized Support

Application Area

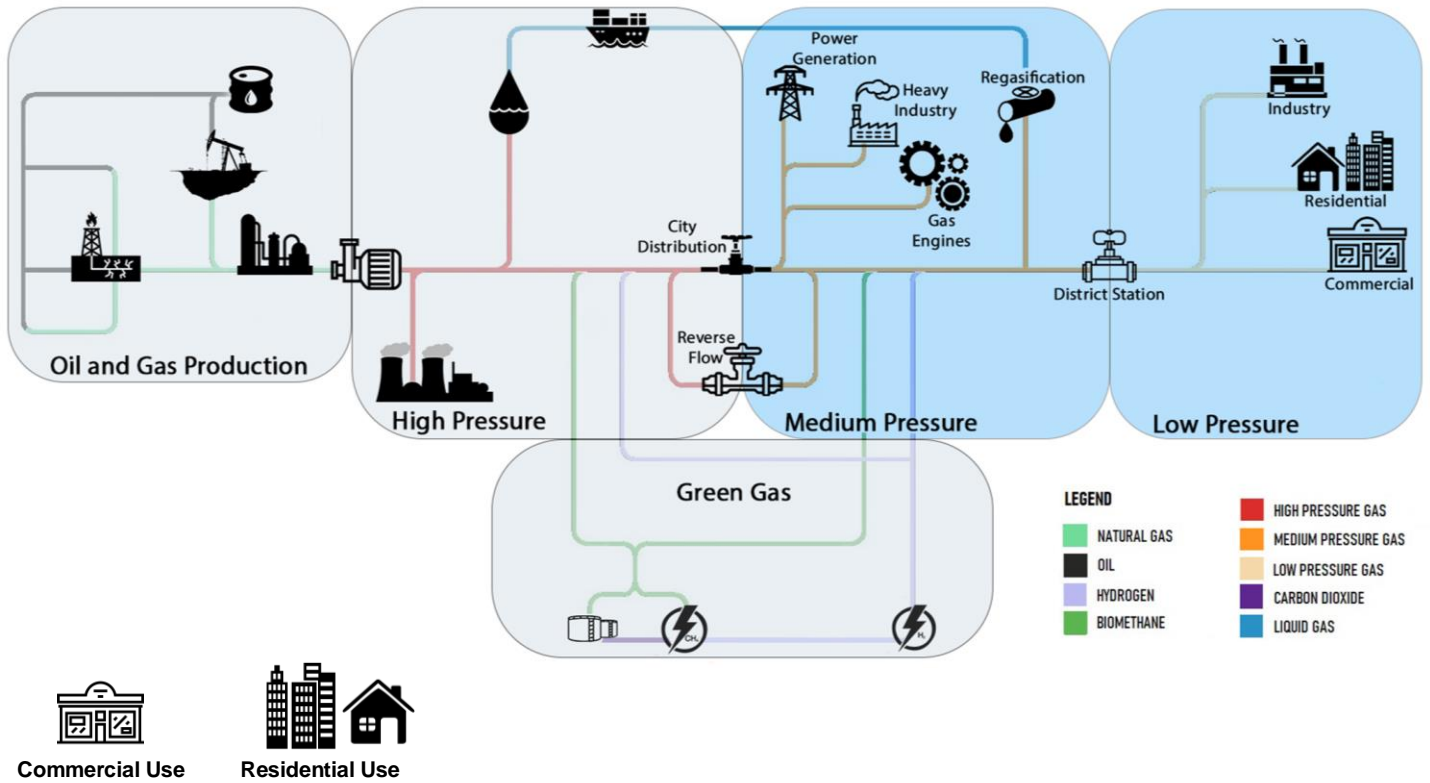

Figure 1: Gas Distribution Map

Introduction

The **ERG-S Series Double Stage Pressure Regulator** is designed for precise pressure regulation on gas lines, reducing inlet pressure to the desired outlet level with high accuracy. ERG SE is designed with a first-stage pressure reduction that controls the pressure delivered to the second stage, enabling it to achieve optimal precision. Suitable for both commercial and domestic applications, it can be directly installed on gas meters, offering exceptional operational reliability.

Its modular design and the availability of a wide range of inlet and outlet connection options make the ERG-S Series compatible with various pipe diameters and thread standards, ensuring easy integration with different systems. This flexibility allows it to meet diverse customer requirements while ensuring a straightforward installation process.

The regulators are manufactured according to Ped Directive 2014/68/EU. The functional tests are performed according to EN334 and EN 88-2.

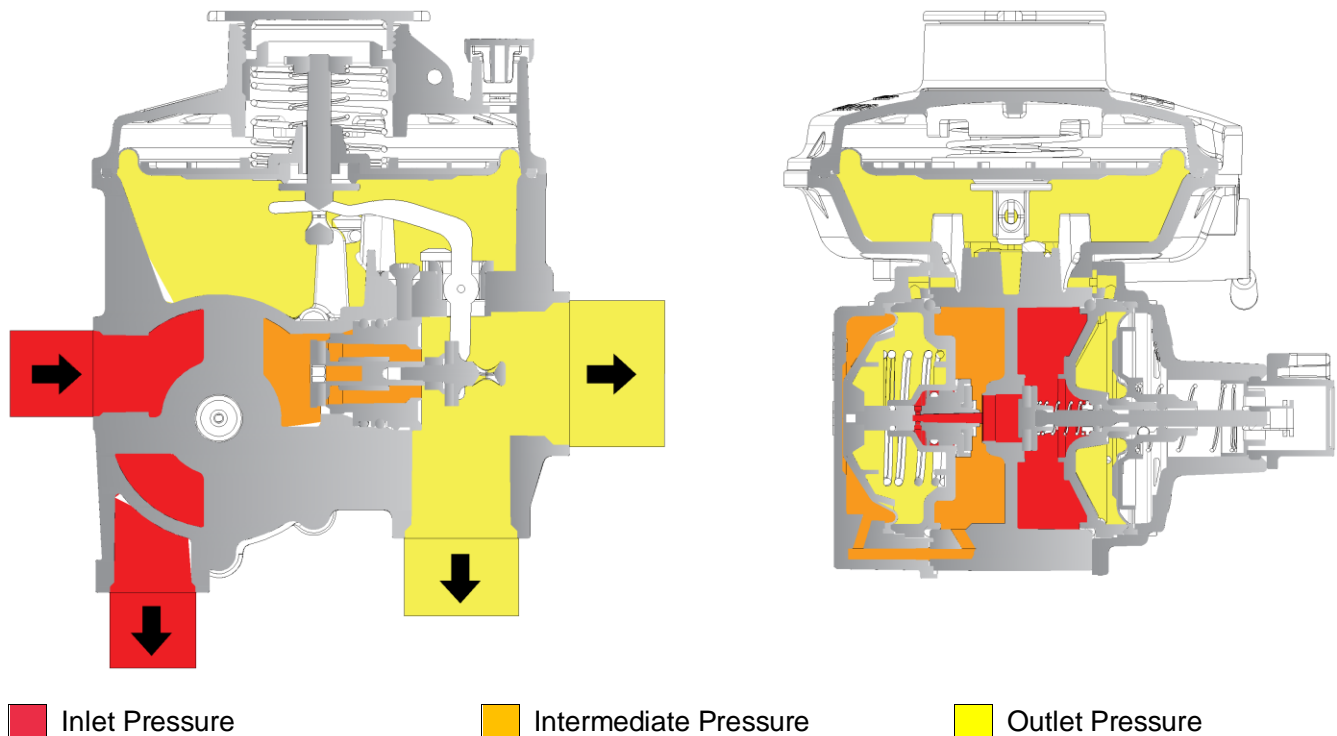

Figure 2: ERG SE Pressure Display

Features

The **ERG-SE** pressure regulator is designed for medium-pressure gas lines in both domestic and commercial applications. It offers a range of advanced features, including an optional metallic mesh filter that ensures easy maintenance and extends the operational life of the regulator.

The outlet pressure tolerance is highly precise, with options of $\pm 10\%$ (AC10) or $\pm 5\%$ (AC5), while the lock-up pressure tolerance is up to $+20\%$ (SG20) for outlet pressures up to 100 mbar, with SG20 and SG10 available for higher pressures.

The regulator supports inlet pressures up to 6 bar and provides an adjustable outlet pressure range from 18 to 500 mbar using interchangeable springs. Additional options include an incorporated Under Pressure Shut Off Valve and an internal relief valve for enhanced safety and reliability.



Figure 3: ERG SE (OPSO version)



Figure 4: ERG S (Non-OPSO version)

Characteristics

Table 1: ERG-S Series characteristics

Feature	Values			
Design Pressure	PS6			
Inlet Pressure ³	0.1 to 6 bar			
Flow	1,6 to 60 m ³ /h			
	LPO Version		MPO Version	
Outlet Pressure Range (Wd) ³	13-180 mbar		180-500 mbar	
Safety shut-off Pressure Range (Wdo)	35-800 mbar			
Accuracy Class (AC)	±5% AC5 ¹ , ±10% AC10 or ±20% AC20 ¹			
Lock-up over pressure (SG)	±10% SG10 ¹ , ±20% SG20 or ±30% SG30 ¹			
	Standard Versions		LT Version²	
Ambient temperature	-10°C to 60°C		-20°C to 60°C	-40°C to 60°C
Configuration	Inline	Angle	U Type	Q Type
Connections	Standard Inlet DN15 and Outlet DN20 or DN25 with different connection options ⁴			
¹ Upon request ² The stated value is the temperature at which the device's mechanical resistance and leakage are tested. Extra body parts may not be suitable for that version. ³ The standard inlet and outlet pressure are set as per TS EN 10624, EN 88-1, EN 88-2 ⁴ Different modular connection options include BSPP, BSPT and NPT				

Materials and Approvals

Table 2: ERG-S Series Materials and Approvals

Part	Material*	Standard
Body and Cover	Aluminium	EN 1706
	Zamak	EN 1774
Diaphragm and Seat	Nitril Rubber	EN 549
	Zamak, Aluminium	EN 1774, EN 1706
*Above materials are listed for standard models. For other request please refer to our sales team or your local distributor.		

The ERG-S Series regulator is designed according to European standard EN 334, EN 88-2. The regulator reacts in opening (Fail Open) according to EN 334. The product is certified according to European Directive 2014/68/EU (PED)



EN 334



EN 88-2



NF 2-190-29



TS 10624



PED



GAD

Technical Data

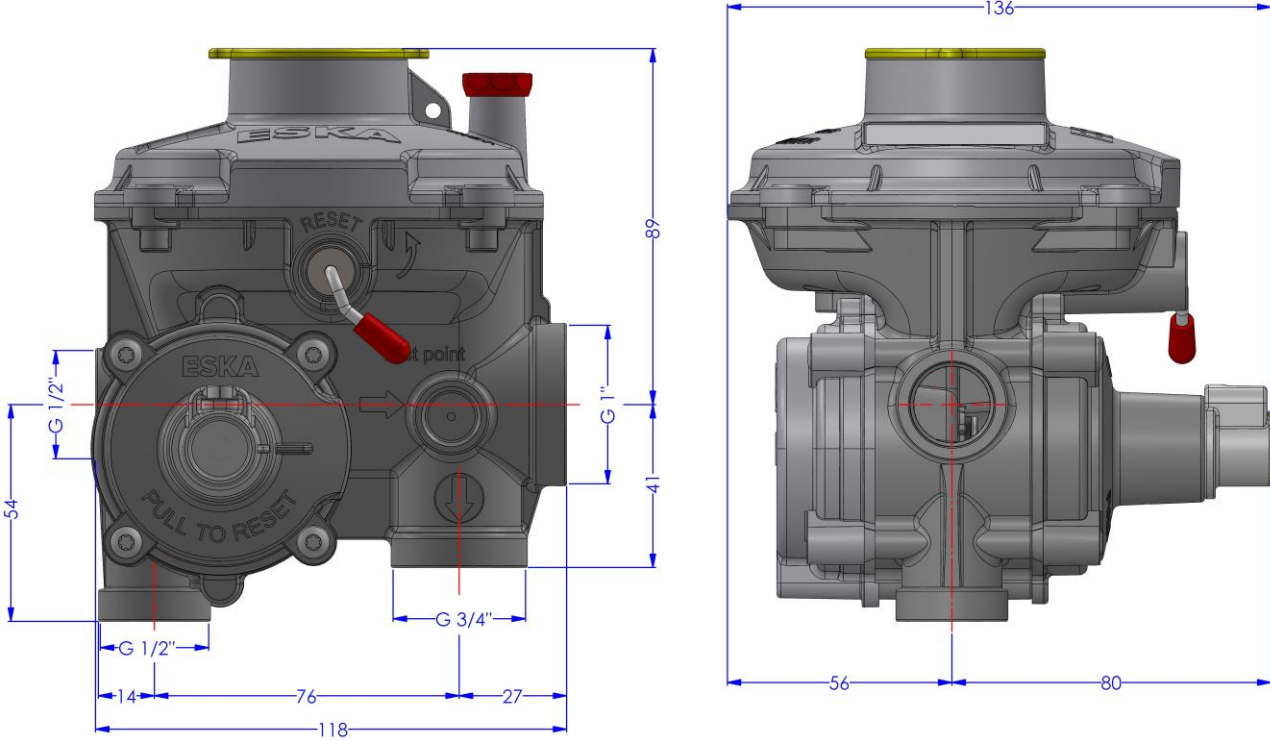

Figure 5: ERG-SE Technical Dimensions

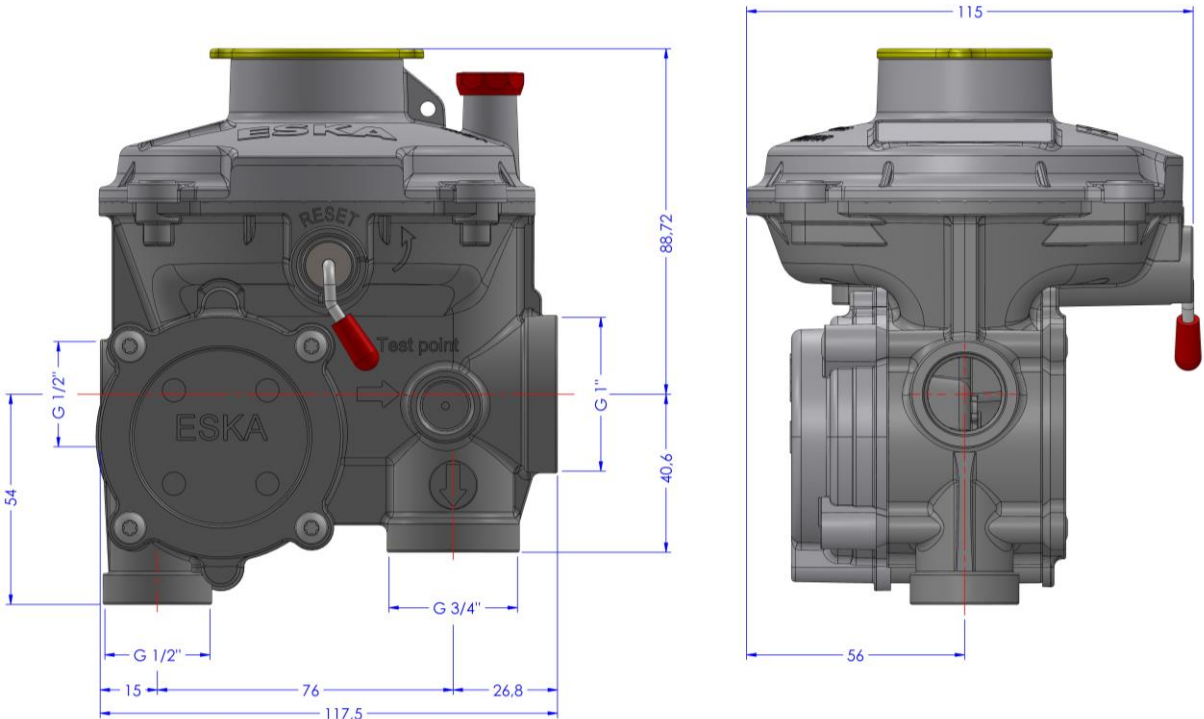

Figure 6: ERG-S Technical Dimensions

Capacity Table

Table 4: ERG-S Series Capacity Table

ERG-S/SE Capacities										
Inlet Pressure			Outlet Pressure							
			21(mbar)/2,1kPa		21(mbar)/2,1kPa		21(mbar)/2,1kPa		21(mbar)/2,1kPa	
			ERG-SE 6 m ³		ERG-SE 10 m ³		ERG-SE 25 m ³		ERG-SE 50 m ³	
mbarg	PSI	kPa	Sm ³ /h	Kg/h	Sm ³ /h	Kg/h	Sm ³ /h	Kg/h	Sm ³ /h	Kg/h
50	0,73	5	2	2,3	3,8	4,3	6	6,8	6	6,8
100	1,45	10	3	3,4	5,7	6,5	10,5	12,0	11	12,5
200	2,9	20	4,7	5,4	9	10,3	17,5	20,0	17,5	20,0
300	4,35	30	6	6,8	10	11,4	25	28,5	25	28,5
400	5,8	40	6	6,8	10	11,4	25	28,5	31	35,3
500	7,25	50	6	6,8	10	11,4	25	28,5	38	43,3
600	8,7	60	6	6,8	10	11,4	25	28,5	45	51,3
700	10,15	70	6	6,8	10	11,4	25	28,5	50	57,0
800	11,6	80	6	6,8	10	11,4	25	28,5	50	57,0
900	13,05	90	6	6,8	10	11,4	25	28,5	50	57,0
1000	14,5	100	6	6,8	10	11,4	25	28,5	50	57,0
2000	29,01	200	6	6,8	10	11,4	25	28,5	50	57,0
3000	43,51	300	6	6,8	10	11,4	25	28,5	50	57,0
4000	58,02	400	6	6,8	10	11,4	25	28,5	50	57,0

* Values in the table are for AC10.
 * Kg/h values are for LPG
 * Sm³/h values are for Natural Gas

Regulation Spring Table

Table 5: ERG S Series Regulation Spring Table

Regulation Spring		LP Spring Range (mbar)		HP Spring Range (mbar)	
Spring Code	Spring Color	Min.	Max.	Min.	Max.
PDM00002062	No Color	21	21	-	-
PDM00002172	Red	130	180	300	420
PDM00002290	Yellow	-	-	285	330
PDM00002176	Red	21	21		
PDM00002292	Blue	80	110	180	260
PDM00002299	White	20	-	-	-
PDM00002300	Yellow	18	30	-	-
PDM00002301	White	150	200	350	500
PDM00002302	Blue	18	25	-	-
PDM00002303	Red	25	35	-	-
PDM00002304	Yellow	35	55	-	-
PDM00002305	Orange	55	80	-	-
PDM00002306	Black	-	-	90	130
PDM00002307	Red	18	25	-	-
PDM00003839	Grey	21	21	-	-
PDM00007127	No Color	13	18	-	-
PDM00003849	No Color	14	16	-	-
PDM00003702	Blue	95	110	-	-
PDM00009133	Purple	14	16	-	-
PDM00009165	Green	19	-	-	-
PDM00009184	Purple	-	-	390	500

OPSO Spring Table

Table 6: ERG-SE OPSO Spring Table

OPSO Springs		Spring Range (mbar)	
Spring Code	Spring Color	Min.	Max.
PDM00002189	Blue	35	50
PDM00002078	Yellow	50	65
PDM00002235	Red	65	90
PDM00002237	Blue	75	105
PDM00002239	Yellow	100	150
PDM00002240	Red	135	195
PDM00002244	Blue	190	300
PDM00002246	Yellow	290	460
PDM00002247	Red	450	800

Relief Spring Table

Table 7: ERG-S Series Relief Spring Table

Relief Springs		LP Spring Range (mbar)		HP Spring Range (mbar)	
Spring Code	Spring Color	Min.	Max.	Min.	Max.
PDM00002252	White	7	16	30	50
PDM00002069	Green	17	25	50	75
PDM00002253	Orange	20	40	75	110
PDM00003723	Black	40	55	110	150
PDM00002244	Blue	55	80	150	260
PDM00002246	Yellow	-	-	260	520

Connections

Applicable thread types for inlet and outlet modular connections are BSPP, BSPT and NPT, with dimensions ranging from 1/2" to 1 1/4".

Threaded connections as EN 10266-2, TS EN ISO 228-1, ASME B1.20.1 NPT Standards.

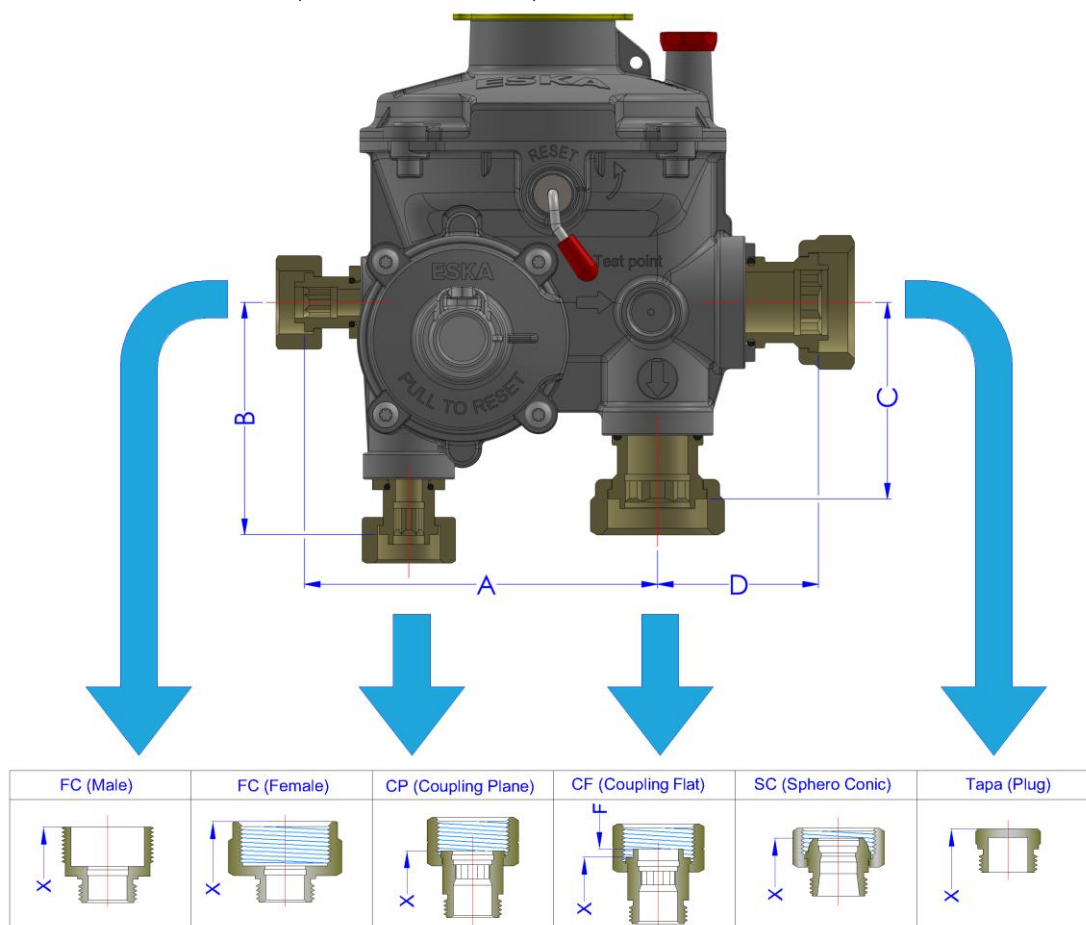

Packaging

Table 8: ERG-S Series Packing Information

Product	Number or Items	Box Dimensions (LxWxH cm)	Unit Weight	Package Size (LxWxH cm)	Number of Boxed Products in 1 Package	Package Weight	Total Package Weight	Pallet Total Items	Pallet Total Weight
ERG-SE	1	15x14,5x16	Approximately 1,15kg	33x58x35	16	0,65 kg	19,5 kg	480	Approximately 600 kg
ERG-S	1	15x14,5x16	Approximately 1,10kg	33x58x35	16	0,65 kg	18,2 kg	480	Approximately 580 kg

ESKA



ERG-S Series
USER MANUAL

This manual is subject to change according to technical developments.

www.eskavalve.com